

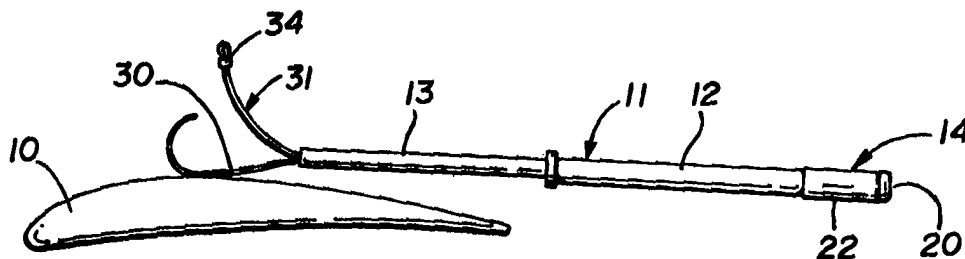

INTERNATIONAL APPLICATION PUBLISHED UNDER THE PATENT COOPERATION TREATY (PCT)

<p>(51) International Patent Classification⁶ : F16H 37/12, F16C 23/00</p>	<p>A1</p>	<p>(11) International Publication Number: WO 98/39582 (43) International Publication Date: 11 September 1998 (11.09.98)</p>
<p>(21) International Application Number: PCT/US97/03352 (22) International Filing Date: 3 March 1997 (03.03.97) (71) Applicant: THE TORAX COMPANY, INC. [US/US]; Suite 107, 2360 West Dorothy Lane, Dayton, OH 45439 (US). (72) Inventor: LOHR, Charles, B.; 3875 Traine Drive, Kettering, OH 45429 (US). (74) Agent: KNECHT, Harold, C., III; Killworth, Gottman, Hagan & Schaeff, L.L.P., One Dayton Centre, Suite 500, One South Main Street, Dayton, OH 45402-2023 (US).</p>		<p>(81) Designated States: AL, AM, AT, AU, AZ, BA, BB, BG, BR, BY, CA, CH, CN, CU, CZ, DE, DK, EE, ES, FI, GB, GE, HU, IL, IS, JP, KE, KG, KP, KR, KZ, LC, LK, LR, LS, LT, LU, LV, MD, MG, MK, MN, MW, MX, NO, NZ, PL, PT, RO, RU, SD, SE, SG, SI, SK, TJ, TM, TR, TT, UA, UG, UZ, VN, ARIPO patent (GH, KE, LS, MW, SD, SZ, UG), Eurasian patent (AM, AZ, BY, KG, KZ, MD, RU, TJ, TM), European patent (AT, BE, CH, DE, DK, ES, FI, FR, GB, GR, IE, IT, LU, MC, NL, PT, SE), OAPI patent (BF, BJ, CF, CG, CI, CM, GA, GN, ML, MR, NE, SN, TD, TG).</p> <p>Published <i>With international search report.</i></p>

(54) Title: A TOROIDAL DRIVE TYPE TRANSMISSION AND COMPONENTS THEREOF



(57) Abstract

A transmission (10) having a power input and output that run along the same axis without having to use parallel shafting. The transmission (10) includes a toroidal drive (12) and a co-axial drive (16), with the co-axial drive (16) having a rotating planetary carrier (36) that bisects the reaction path between one disk pair of the toroidal drive (12). With such a bisecting carrier (36), the present co-axial drive (16) enables power from an input shaft (18) to be transmitted to a co-axial output shaft (95) in a compact and space saving manner.

FOR THE PURPOSES OF INFORMATION ONLY

Codes used to identify States party to the PCT on the front pages of pamphlets publishing international applications under the PCT.

AL	Albania	ES	Spain	LS	Lesotho	SI	Slovenia
AM	Armenia	FI	Finland	LT	Lithuania	SK	Slovakia
AT	Austria	FR	France	LU	Luxembourg	SN	Senegal
AU	Australia	GA	Gabon	LV	Latvia	SZ	Swaziland
AZ	Azerbaijan	GB	United Kingdom	MC	Monaco	TD	Chad
BA	Bosnia and Herzegovina	GE	Georgia	MD	Republic of Moldova	TG	Togo
BB	Barbados	GH	Ghana	MG	Madagascar	TJ	Tajikistan
BE	Belgium	GN	Guinea	MK	The former Yugoslav Republic of Macedonia	TM	Turkmenistan
BF	Burkina Faso	GR	Greece	ML	Mali	TR	Turkey
BG	Bulgaria	HU	Hungary	MN	Mongolia	TT	Trinidad and Tobago
BJ	Benin	IE	Ireland	MR	Mauritania	UA	Ukraine
BR	Brazil	IL	Israel	MW	Malawi	UG	Uganda
BY	Belarus	IS	Iceland	MX	Mexico	US	United States of America
CA	Canada	IT	Italy	NE	Niger	UZ	Uzbekistan
CF	Central African Republic	JP	Japan	NL	Netherlands	VN	Viet Nam
CG	Congo	KE	Kenya	NO	Norway	YU	Yugoslavia
CH	Switzerland	KG	Kyrgyzstan	NZ	New Zealand	ZW	Zimbabwe
CI	Côte d'Ivoire	KP	Democratic People's Republic of Korea	PL	Poland		
CM	Cameroon	KR	Republic of Korea	PT	Portugal		
CN	China	KZ	Kazakstan	RO	Romania		
CU	Cuba	LC	Saint Lucia	RU	Russian Federation		
CZ	Czech Republic	LI	Liechtenstein	SD	Sudan		
DE	Germany	LK	Sri Lanka	SE	Sweden		
DK	Denmark	LR	Liberia	SG	Singapore		
EE	Estonia						

A TOROIDAL DRIVE TYPE TRANSMISSION AND COMPONENTS THEREOF

FIELD OF THE INVENTION

The present invention is related to transmissions and components used therein, more particularly, to toroidal drive type transmissions and, even more particularly, to co-axial drives, trunnion/roller assemblies, and trunnion linkage systems for toroidal drive type transmissions. The present invention is also related to components such as thrust bearings that may be used in transmissions or other mechanisms, more particularly to a thrust bearing assembly having a thrust bearing and a load bearing spring and, even more particularly, to a needle thrust bearing assembly, with a washer-shaped load bearing spring having a convex side crown facing a needle thrust bearing, and an apparatus mounting such a thrust bearing assembly.

BACKGROUND OF THE INVENTION

Many types of engine transmissions have been developed in the past. One type is a continuously variable transmission which typically includes a toroidal drive having at least one pair of traction or toric disks which react upon each other and which are rotatably supported in a housing along an axis opposite one another to define a toric cavity between them. Two motion transmitting traction rollers are typically disposed in each toric cavity in engagement with the toric disks. Each traction roller is supported by a trunnion so as to form a traction trunnion/roller assembly. Each traction roller is frictionally engaged with the toric disks in circles of varying diameters depending on the transmission ratio, and is supported so that it can be moved to initiate a change in the transmission ratio. Each trunnion can be axially movable (i.e., end supported) or tiltable (i.e., pivoted about a point) for initiating changes in the transmission ratio between the toric disks. A toroidal type continuously variable drive can have one or more cavities.

A common type of continuously variable transmission includes a toroidal drive having dual cavities which are defined by two torsionally coupled outboard traction disks which react upon each other and two inboard disks which are positioned between the outboard disks and also react upon each other. One

dual cavity toroidal drive of the "off-center type" is disclosed in U.S. Patent No. 5,368,529. An off-center toroidal drive is usually considered one having an included angle of less than 180° between the traction contacts (i.e., where the roller contacts the disks). An on-center toroidal drive is usually considered one having an included angle of about 180°. The included angle is the angle formed by the lines between the center of the toric cavity and the traction contacts on engaged disks. The usual method for transmitting power through a dual cavity design of the "off-center type" is to input the power to the two outboard disks and use parallel shafting and gearing to transmit power from the inboard disks. One gear mesh used to effect this parallel shafting is usually trapped between the inboard disks. Such a two-shaft system is bulky and difficult, if not impossible, to fit into the available space provided for the transmission of a number of vehicles. In addition, it is often necessary to return to the original center line when transmitting power. In the past, this has required a second gear mesh to be used, in addition to the gear mesh between the inboard disks. Single cavity toroidal drives are also known to take up more space than desired.

Therefore, there is a need for a toroidal type transmission capable of inputting and outputting power along the same axis without having to use parallel shafting. Such a co-axial drive transmission takes up less space than parallel shaft transmissions and can therefore be used in applications with tighter space constraints. In addition, it is easier and less expensive to package a co-axial drive transmission in a housing than it is to so package a parallel shaft transmission.

For the transmission of large torques, the contact or engagement forces between the traction rollers and the toric disks are rather large. U.S. Patent No. 5,299,987 discloses a tiltable traction trunnion/roller assembly which includes a load piston for pushing the traction roller against the corresponding toric disks with sufficient force to prevent slippage along the interface between the roller and toric disks as the disks are rotating. The load piston is able to produce the large engagement forces required to transmit large torques using relatively low hydraulic pressures because the loading force

from the piston is amplified through a plurality of load levers.

Even so, there is a continuing need for an improved toroidal drive type transmission with a trunnion/roller assembly having a lever assisted load piston.

5 One type of trunnion is axially movable for initiating changes in the transmission ratio between the toric disks. The axial translation of such a trunnion/roller assembly, while engaged with a toric disk, can also cause the trunnion to rotate. Axially moveable trunnions are typically end supported
10 by a linkage system. Either end of each trunnion is connected into the linkage system by a bearing system. One such bearing system includes a ball/socket joint that handles the axial translation of the trunnion and an anti-friction bearing that handles the trunnion rotation. Such prior toroidal drives can
15 be susceptible to imbalance problems, especially under prolonged heavy loading, where the rollers end up driving different toric disks at different speeds. Such an imbalance in the toroidal drive can cause significant energy losses and increased wear and tear, which can lead to premature failure of the toroidal drive
20 and the overall transmission.

There can be a difference between the theoretical or nominal center and the actual center of each toric cavity of a toroidal drive transmission. Without the ability to adjust for such misalignments, one contacting roller and toric disk could
25 be more heavily loaded than another, resulting in one or both ends of the trunnion being overloaded. One solution to this problem is a trunnion/roller assembly, such as that disclosed in U.S. Patent No. 5,547,432, that allows its corresponding roller to move within the trunnion so as to compensate for such
30 a mismatch. However, this type trunnion/roller assembly is expensive and not readily adaptable to other trunnion/roller assembly designs.

Compression springs have also been used in the linkage system of prior toroidal drives to support and maintain centered
35 movement of the trunnion/roller assemblies within their respective toric cavities. These compression springs typically exhibit a high spring rate (i.e., a spring force that changes a relatively large amount over the compression range of the spring) and are sized and positioned with a great deal of

accuracy to insure proper centering of the trunnion/roller assemblies in the cavities. Such linkage systems are relatively expensive and can experience misalignment problems.

Therefore, there is also a need for a more reliable and inexpensive system of linking axially moveable trunnion/roller assemblies, in a toroidal drive type transmission, which is less likely to exhibit imbalance or misalignment problems, even under prolonged heavy loading.

A thrust bearing includes a plurality of roller bearings mounted circumferentially within an annular cage having an inner and outer diameter. The thrust bearing is typically mounted in a gap formed between two separated elements of some type of mechanism such as, for example, an automobile transmission. The gap is usually defined by two generally parallel surfaces of the elements, where at least one of the surfaces is rotatable about an axis of rotation relative to the other surface. The elements are typically subjected to an applied load along the axis of rotation which tends to compress the two surfaces together. The thrust bearing is mounted in the gap so as to be sandwiched between the two elements and centered around the axis of rotation. A thrust washer made of bearing steel or other such material is often positioned on one or both sides of the thrust bearing to protect one or both elements from wear.

Needle thrust bearings, which use needle rollers, are desirable because they take up the least amount of space compared to any other roller (anti-friction) thrust bearing. In a needle thrust bearing, each needle roller has an outer end adjacent the outer diameter of the roller cage and an inner end adjacent the inner diameter of the roller cage. Because each needle roller is rolling at the same speed along its length, the inner and outer ends of each needle roller slip in opposite directions. This opposite slipping of the roller ends can impact the performance of the system containing the two elements and cause power losses. In addition, such slippage can produce enough friction generated heat to reduce the life of the thrust bearing. The problems associated with such slipping of the needle rollers typically increase as the normal load on the thrust bearing increases (e.g., as the two elements are

compressed together), effectively limiting the use of needle thrust bearings to relatively light axial-load or no axial-load applications.

5 In an effort to prevent such slippage and the associated power losses and friction generated heat, thrust bearings have been designed with tapered rollers. However, thrust bearings with tapered rollers are much thicker and require more space than thrust bearings with needle rollers. In addition, thrust bearings with tapered rollers are typically
10 more expensive than needle thrust bearings.

Therefore, there is a further need for a way to use a thrust bearing with needle rollers, even under heavy axial-loading conditions, while significantly reducing, if not eliminating, the problems associated with slippage at either end
15 of the needle rollers.

SUMMARY OF THE INVENTION

To satisfy at least one of the above needs, a transmission is provided which has a power input and output that run along the same axis of rotation without having to use
20 parallel shafting.

In one aspect of the present invention, a transmission is provided which includes a first drive having an input shaft for supplying power to the transmission, an output and a co-axial drive interconnecting the first drive and the output. The
25 first drive, the output and the co-axial drive are operatively adapted for allowing power from the input shaft to be transmitted through the first drive, through the co-axial drive and to the output along substantially the same axis of rotation as that of the input shaft. The first drive, output and co-
30 axial drive are also operatively adapted for allowing power from the output to be transmitted through the co-axial drive through the first drive and back to the input shaft also along substantially the same axis of rotation as that of the input shaft. In this way, the transmission is capable of exhibiting
35 a recirculatory power loop from and back to the input shaft without the need for parallel shafting.

In one feature of this aspect of the present invention, the co-axial drive is a planetary drive with a

carrier, and the first drive is a toroidal drive with two coupled traction disks which react at least torsionally, and preferably both torsionally and axially, to one another through the carrier. The toroidal drive can be a dual cavity type, with
5 two outboard traction disks and one inboard traction disk element or two separate inboard traction disks disposed between the outboard disks. The toroidal drive can also be a single cavity type. One of the traction disks can be mounted to rotate with the input shaft, and the carrier operatively adapted to
10 rotate with the input shaft and the other traction disk.

The co-axial drive may be any suitable type of planetary drive including a planetary gear assembly. The carrier for such a co-axial drive can include a hub mounted to rotate with the input shaft and a support flange mounted to
15 rotate with the other traction disk (the one that is not mounted to rotate directly with the input shaft). Preferably, the axial position of the traction disks and planetary assembly are substantially maintained relative to one another.

The traction disks and planetary assembly can be
20 axially held in place with two stops mounted on the input shaft. The toroidal drive and the planetary assembly are held axially between these two stops so that relative axial movement between the various components of the toroidal drive and planetary assembly is substantially limited. As a consequence, relative
25 movement between these various components is substantially only rotational in nature, thereby eliminating the need for axial load bearings with each traction disk. The hub of the carrier and one of the traction disks can each be seated against one of the stops in order to obtain this reduction in relative axial
30 movement.

Another aspect of the present invention is a transmission of the type which includes a toroidal drive and a co-axial drive, with the co-axial drive having a rotating planetary carrier that bisects the reaction path between one
35 disk pair of the toroidal drive. With such a bisecting carrier, the present co-axial drive enables power from an input shaft to be transmitted to a co-axial output shaft in a compact and space saving manner.

In one feature of this aspect of the present

invention, the toroidal drive has two traction disks with at least one reaction path therebetween. The traction disks react at least axially or torsionally along one reaction path, and preferably, the traction disks react axially and torsionally along one reaction path, with the carrier bisecting the one reaction path.

The toroidal drive can be a single cavity toroidal drive or, more desirably, a dual cavity toroidal drive having two outboard traction disks which react axially and torsionally along at least one reaction path, with the coaxial carrier bisecting this at least one reaction path. The dual cavity toroidal drive also has two inboard traction disks which can be integrally formed into a single element.

The co-axial drive has a plurality of elements carried by its carrier. These elements are operatively adapted to provide a power path between the input and output of the transmission.

In a further aspect of the present invention, a transmission is provided which includes an input and output shaft having substantially coaxial axes of rotation, a toroidal drive with a reaction path between two of its traction disks, and a co-axial drive having a planetary assembly with a rotating planetary carrier bisecting the reaction path between the disks. The input shaft supplies power to the transmission and the output shaft transmits power out of the transmission. One of the traction disks is mounted for rotation with one of these shafts, and the planetary carrier connects together the toroidal drive and the shaft mounting the traction disk. The toroidal drive and the planetary assembly are operatively adapted for allowing power from the input shaft to travel back and forth through the transmission, between the input and output shafts and along the axis of rotation of these shafts, without the need for parallel shafting.

In one feature of this aspect of the present transmission, power is able to travel from and back to the input shaft through the toroidal drive and planetary assembly. The toroidal drive and planetary assembly are operatively adapted for allowing power from the input shaft to be transmitted to the planetary assembly through the toroidal drive, as well as from

the input shaft through the planetary assembly, then through the toroidal drive and back to the input shaft. This flow of power from and back to the input shaft all occurs along substantially the same axis of rotation.

5 To satisfy at least an additional one of the above described needs, an improved traction trunnion/roller assembly is provided which has a lever assisted load piston, according to the present invention, and which is mountable between a pair of traction disks in a toroidal drive.

10 In one aspect of the present invention, the trunnion/roller assembly comprises a traction roller, a roller loading assembly and a trunnion mounting the traction roller and the roller loading assembly. The roller loading assembly applies an axial loading force to the traction roller to provide
15 a contact force (i.e., the normal force) between the traction roller and a traction disk. The roller loading assembly comprises a load piston and a plurality of levers. The load piston has a face and an alignment shaft that extends out from the face and at least into a through hole or a blind hole formed
20 in the traction roller in order to provide the roller with enough stability to at least limit wobbling or rocking of the traction roller. The levers are mounted around the alignment shaft with each lever having an end in position to at least be contacted by the load piston face. These levers are operatively
25 adapted to amplify the loading force being applied by the load piston. This aspect of the present invention is not limited to a particular type of trunnion. For example, the trunnion used can be an axially movable type (e.g., end supported) or a tiltable type (e.g., pivoted about a point).

30 It is desirable for the contact force provided by the applied axial loading force to be sufficient to maintain contact and proper loading between the traction roller and the traction disk. It is also desirable for the alignment shaft to extend substantially into or through the hole formed in the traction
35 roller to provide the roller with enough stability to prevent such wobbling or rocking. It may be desirable for the end of each of the levers to be in contact with the load piston face and the alignment shaft. When the lever ends are in contact with the alignment shaft, it is desirable for each lever end to

be chamfered so as to angle away from the alignment shaft and toward the load piston face.

This aspect of the present trunnion/roller assembly can include a thrust plate mounted between the levers and the traction roller. The thrust plate can include an alignment collar which extends from the thrust plate. This alignment collar is disposed around the alignment shaft and extends into the hole formed in the traction roller. It is desirable for the alignment collar to form a slip fit around the alignment shaft. A slip fit refers to one element being fit inside another element so as to allow movement of one element in and out of the other (i.e., axial sliding) but not allow the inside element to move a substantial amount from side-to-side within the other element. It is also desirable for the thrust plate to have an outer surface mounted within the trunnion so as to form such a slip fit.

This aspect of the present trunnion/roller assembly can also include one or more springs mounted in the trunnion so as to apply an axial preload force on the load piston in a direction to extend the load piston toward the roller.

In addition, this aspect of the present trunnion/roller assembly can include a spring loaded check valve hydraulically interconnected with the roller loading assembly and used in controlling movement of the trunnion (e.g., axial movement of an axially moveable trunnion or pivoting of a tiltable trunnion) and hydraulic pressure applied to the load piston. The trunnion/roller assembly can include a ratio control assembly hydraulically interconnected with the roller loading assembly for controlling the movement of the trunnion and hydraulic loading applied by the load piston. When the trunnion is an axially moveable trunnion, the ratio control assembly can include a control piston with a fluid chamber located on either side of the control piston for axially moving the trunnion. The control piston includes one or more spring loaded check valves for hydraulically interconnecting the ratio control assembly with the roller loading assembly while isolating each fluid chamber from one another. Each check valve can be a single action or a double action check valve.

Another aspect of the present invention is a trunnion/roller assembly which includes a trunnion mounting a traction roller and a roller loading assembly. The roller loading assembly of this trunnion/roller assembly has a load piston through which the axial loading force is applied, one or more springs mounted so as to apply an axial preload force on the load piston, and a plurality of levers mounted between the load piston and the traction roller for amplifying the axial loading force being applied. The load piston of this trunnion/roller assembly may or may not include an alignment shaft. The one or more springs apply the preload force in a direction to extend the load piston toward the traction roller. A series of springs (e.g., wave or dish springs) can be mounted between the load piston and the trunnion.

This aspect of the present trunnion/roller assembly can include a thrust plate mounted between the levers and the traction roller. The thrust plate can be adapted to accommodate a load piston with an alignment shaft. It is desirable for the thrust plate to have an outer surface mounted within the trunnion so as to form a slip fit. This aspect of the present trunnion/roller assembly can also include the ratio control assembly described herein. In addition, if the load piston has an alignment shaft, this aspect of the present trunnion/roller assembly can include all of the features associated with such an alignment shaft, as described herein.

An additional aspect of the present invention is a trunnion/roller assembly that includes a trunnion mounting a traction roller, a roller loading assembly and a thrust plate. The roller loading assembly of this trunnion/roller assembly has a load piston through which the axial loading force is applied, and a plurality of levers mounted between the load piston and the traction roller for amplifying the axial loading force being applied. The load piston of this trunnion/roller assembly may or may not include an alignment shaft. The thrust plate is mounted between the levers and the traction roller and has an outer surface mounted within the trunnion so as to form a slip fit.

The thrust plate of this aspect of the present trunnion/roller assembly can include an alignment stud that

extends from the thrust plate and into a hole formed in the traction roller. It is desirable for the alignment stud to be fixed to the traction roller in such a way that the alignment stud is not allowed to move a substantial amount from side-to-side within the hole formed in the traction roller (i.e., not enough to allow the traction roller to wobble or rock a detrimental amount).

A further aspect of the present invention is a trunnion/roller assembly which includes a moveable trunnion mounting a traction roller and a roller loading assembly, and a spring loaded check valve hydraulically interconnected with the roller loading assembly and used in controlling movement of the trunnion and hydraulic pressure applied to the load piston. The roller loading assembly includes a load piston through which the axial loading force is applied and a plurality of levers mounted between the load piston and the traction roller for amplifying the axial loading force being applied. The trunnion/roller assembly can include a ratio control assembly hydraulically interconnected with the roller loading assembly for controlling the movement of the trunnion and hydraulic loading applied by the load piston. When the trunnion is an axially moveable trunnion, the ratio control assembly can include a control piston with a fluid chamber located on either side of the control piston for axially moving the trunnion. The control piston includes one or more spring loaded check valves for hydraulically interconnecting the ratio control assembly with the roller loading assembly while isolating each fluid chamber from one another. For an axially moveable trunnion that is end supported, it is desirable for the ratio control assembly to be operatively adapted so that the control piston has the freedom to move from side-to-side in response to axial movement of the trunnion.

To satisfy at least one more of the above described needs, a trunnion linkage system is provided for linking together opposite ends of a plurality of axially moveable trunnion/roller or trunnion assemblies in a toroidal drive type transmission. The present linkage system is operatively adapted and mountable in the transmission so as to allow each trunnion assembly to freely move along a substantially axial direction

and rotate about a longitudinal axis thereof. Compared to other linkage systems, the present trunnion linkage system is less likely to exhibit imbalance or misalignment problems, even under prolonged heavy loading. As a result, the present linkage system prevents, or at least significantly inhibits, offsetting and roller fighting between opposing trunnion assemblies. The present trunnion linkage system is also more reliable while being relatively inexpensive.

In one aspect of the present invention, a trunnion linkage system is provided which includes a first or top set of links and a second or bottom set of links. Each set of links includes one or more cross links and two side links, each of the links has opposite ends. Each side link mounts one or more trunnion bearings, and each cross link mounts a link or end bearing at spaced locations thereon. Each bearing can be a rolling element bearing or a plane bearing (e.g., a bushing). Each trunnion bearing is mountable on one end of one of the trunnion assemblies so as to allow each of the trunnion assemblies to freely rotate about its longitudinal axis. Each link bearing mounts one end of one of the side links so as to allow each of the trunnion assemblies to freely move axially.

It is desirable for each trunnion and link bearing to be a needle roller bearing. Each needle roller in each link bearing has its longitudinal axis generally parallel with the longitudinal axis of the corresponding side link. Each needle roller in each trunnion bearing has a longitudinal axis that is generally parallel with the longitudinal axis of the corresponding trunnion assembly.

In another aspect of the present invention, a transmission is provided which includes a toroidal drive and a trunnion linkage system according to the present invention. The toroidal drive includes a plurality of axially moveable trunnion assemblies, and a plurality of traction disks defining at least one cavity in which the trunnion assemblies are disposed. The trunnion linkage system links together and supports the trunnion assemblies in the toroidal drive. The linkage system includes a first and second set of links, with each set of links including one or more of the cross links and two of the side links. Each cross link is mounted in the transmission so as to

pivot about a point between its spaced apart link bearings. Each end of the trunnion assemblies mounts one of the trunnion bearings so as to allow each trunnion assembly to freely rotate about the longitudinal axis thereof. Each end of the side links
5 mounts one of the link bearings so as to allow each of the trunnion assemblies to freely move axially.

The present linkage system can include one or more springs (e.g., coil springs) mounted within the transmission so as to support the weight of the links and the trunnion
10 assemblies. Each spring has a low enough spring constant not to substantially determine the axial position of the trunnion assemblies relative to the traction disks. In addition to the one or more springs, the present linkage system can also include one or more pivot pins. One or more of the cross links, of at
15 least one of the sets of links, is mounted in the toroidal drive so as to pivot about or pivot with one pivot pin, as each of the trunnion assemblies moves axially. Each spring is of sufficient spring force and length to support its share of the weight of the links and the trunnion assemblies. The one or more springs also
20 maintain a gap between the one or more pivot pins and one or more corresponding stop surfaces forming part of the transmission. The gap is small enough to prevent the trunnion assemblies from moving a substantial amount out of center with their corresponding cavity. It is desirable for the gap to also
25 be large enough to allow the linkage system and all of the trunnion assemblies to move up and down as a whole.

It is desirable for the spring constants of the one or more springs to be low enough not to substantially determine the axial position of the trunnion assemblies relative to the
30 traction disks. Each spring can be a compression spring. It is desirable for each compression spring to be mounted in the transmission and to be of sufficient spring force and length so as not to be over-compressed (i.e., be overloaded beyond the elastic limit of the spring) or bottomed out (i.e., coil bound)
35 when contact occurs between a pivot pin and a stop surface.

It is desirable for each pivot pin to be disposed in an opening or hole, defined by a portion of the transmission. Each opening is operatively adapted so as to prevent the pivot pin, disposed therein, from moving transversely from side-to-

side an appreciable amount. In this way, one roller can be prevented from extending more than another roller, where the rollers come from opposing trunnion assemblies in the same the cavity.

5 It is desirable for there to be two or more stop surfaces, with one stop surface disposed on either side of each pivot pin and along a direction substantially parallel to the axial direction of movement of the trunnion assemblies. The gap can then be maintained, by the one or more springs, between each
10 pivot pin and the corresponding stop surfaces.

When the toroidal drive is a dual-cavity toroidal drive, a longitudinal reaction occurs in each cavity of the toroidal drive. For a dual-cavity application, the present linkage system can connect the two cavities of the toroidal
15 drive such that the longitudinal reaction of one cavity is balanced by that of the other cavity.

Also, when the toroidal drive is a dual-cavity toroidal drive, it is desirable for a plurality of pivot pins and springs to be used, and each set of links to include at
20 least two cross links. At least one cross link in each cavity is mounted in the toroidal drive with one of the pivot pins so as to pivot about or pivot therewith as each of the trunnion assemblies moves axially. At least one spring is disposed in each cavity to support the weight of the links and the trunnion
25 assemblies and maintain the gap between each of the pivot pins and at least one corresponding stop surface.

It is desirable for the linkage system to include one or more locators to maintain the toroidal drive longitudinally in position within the transmission housing while allowing for
30 some transverse movement of the linkage system therein. The locator can be operatively adapted to constrain the movement of at least one cross link or at least one side link along the longitudinal axis of the transmission by contact with corresponding portions of the transmission.

35 Each of the trunnion bearings can include an inner bushing with a rectangular hole formed therein. Each of the trunnion assemblies can include a trunnion having opposite ends, with each end having a rectangular cross section. Each rectangular end is disposed in and adapted to snugly fit in the

rectangular hole of its corresponding bushing only along two opposing sides.

Trunnion assemblies are typically hydraulically loaded. It is desirable for the trunnion assemblies to be interconnected at the same ends by a train of phase gears. The phase gears prevent the trunnion assemblies from wandering grossly out of rotational phase with each other when the hydraulic loading of the trunnion assemblies is inactive.

The transmission can include a plurality of ratio control assemblies for controlling the axial movement of the trunnion assemblies. Each control assembly includes a control piston, and one end of each trunnion assembly is mounted on and axially moved by each control piston. It is desirable for each of the control assemblies to be operatively adapted so that each control piston has the freedom to move from side-to-side in response to the pivoting of each cross link during the axial movement of the trunnion assemblies.

In an additional aspect of the present invention, a transmission is provided which includes a toroidal drive and a trunnion linkage system. The trunnion linkage system includes at least one first or top link and at least one second or bottom link. The trunnion assemblies are connected at the same end by the at least one first link and at their other end by the at least one second link. At least one spring is mounted in the toroidal drive and is of sufficient spring force and length to support the weight of the first and second link and the trunnion assemblies and maintain a gap between a portion of one link and at least one stop surface forming part of the transmission. The gap is small enough to prevent the trunnion assemblies from moving a substantial amount out of center with their associated cavity.

It is desirable for each spring to be a compression spring having a spring rate that is sufficiently low so that the spring exerts a spring force, over the deflection range of the spring, that does not substantially determine the axial position of the trunnion assemblies relative to the traction disks. It is also desirable for each compression spring to be mounted in the transmission and to be of sufficient spring force and length so as not to be over-compressed or bottomed out when contact

occurs between the portion of one link and the stop surface.

To satisfy at least one other of the above described needs, the present invention provides a needle thrust bearing assembly which significantly reduces, if not eliminates, the problems associated with slippage at the ends of the needle rollers, even in heavy axial-load applications. Such opposite slippage makes it harder for the rollers to roll and, therefore, for the two elements to rotate relative to one another when an axial load is applied (i.e., when the needle bearing is compressed) between the elements. This difficulty in rolling can be caused by friction, when there is slippage in the absence of a lubricating film on the rollers, and/or elasto-hydrodynamic forces, when a lubricating film is present. The losses in performance and the heat generated by such slippage typically increase as the normal load on the thrust bearing increases (i.e., as the two elements are compressed together).

With the present thrust bearing assembly, a force applied along the axis of rotation of the thrust bearing (e.g., a force which compresses the thrust bearing between two elements) is directed more toward the middle (i.e., midway along the length) of each needle roller. The midpoint of each needle roller does not experience the slippage which occurs at its ends and, therefore, will not produce the losses and friction generated heat associated with such slippage. By directing more of the applied normal loads toward the middle of each needle roller, and reducing normal loads in the regions where slippage is the greatest (i.e., the ends of the needle roller), the power losses and friction generated heat produced at either end also decreases. With reduced normal forces at the roller ends, it is easier for the rollers to roll and the two elements to rotate relative to one another, thereby improving the performance and increasing the life of the thrust bearing. In addition, because the associated losses and friction generated heat are reduced, the capacity of the present thrust bearing assembly can be increased by using longer needle rollers.

The present thrust bearing assembly comprises a thrust bearing and at least one load bearing spring such as, for example, a washer-shaped thrust bearing spring according to the principles of the present invention. The thrust bearing has an

axis of rotation and a plurality of circumferentially spaced needle rollers mounted within an annular housing or cage so that each roller is rotatable. The washer-shaped thrust spring or spring washer has a curved cross-section that is operatively adapted so as to direct a normal load more toward the middle of each needle roller than toward its ends. It is desirable for this curved cross-section to flatten on both sides of the middle of each needle roller under a load applied along the axis of rotation

The curved cross-section of one embodiment of the present spring washer has a convex side that faces the thrust bearing. It is desirable for the spring washer to have substantially the same cross-sectional curvature around its entire circumference. It is also desirable for the convex side to have a substantially coplaner inner and outer diameter edge and an apex or crown therebetween which defines a contact circle or ring. It is further desirable for the spring washer to be disposed relative to the thrust bearing so that the contact circle bisects each needle roller about halfway along the length of each needle roller. That is, the spring washer is disposed so that its contact circle crosses over about the midpoint of each needle roller. The contact circle of each spring washer contacts either the needle rollers of the thrust bearing or a thrust washer through which force is transmitted between the needle rollers and the spring washer.

In one embodiment of the present thrust bearing assembly, the convex side of the spring washer directly contacts the needle rollers of the thrust bearing. It may be desirable for the thrust bearing assembly to have a spring washer disposed on either side of the thrust bearing and in contact with the needle rollers.

In another embodiment of the present thrust bearing assembly, a thrust washer is disposed on at least one side of the thrust bearing, and the spring washer is disposed on the other side of the thrust bearing. That is, the thrust bearing has a thrust washer on one side and the spring washer on the other side so as to sandwich the thrust bearing therebetween. It may be desirable for another thrust washer to be disposed between the thrust bearing and the spring washer. It may also

be desirable for the thrust bearing to be sandwiched between two thrust washers and two spring washers, with one thrust washer and one spring washer disposed on either side of the thrust bearing. With such an assembly, the thrust washers are in
5 contact with the needle rollers and a spring washer is in contact with each thrust washer.

The present thrust bearing assembly is intended to be mounted between two opposing surfaces, where at least one of the surfaces is rotatable relative to the other surface about an
10 axis. The present thrust bearing assembly can also be mounted between two opposing surfaces which are rotatable relative to one another about the same axis and in opposite directions. When the present thrust bearing assembly is disposed between such opposing surfaces, it is desirable for the spring washer
15 to be initially compressed (i.e., for the curved cross-section to be somewhat flattened) so as to preload each of the needle rollers of the thrust bearing.

An apparatus which uses the present thrust bearing assembly includes a mechanism with two elements separated by a
20 gap. At least one of the elements is rotatable about an axis relative to the other element. These two elements can also be rotatable relative to one another about the same axis and in opposite directions. The present thrust bearing assembly is mounted in the gap so as to be disposed around the axis and
25 sandwiched between the two elements.

In one embodiment of the present apparatus, one of the elements has an annular shoulder and the thrust bearing assembly is mounted on the shoulder. The shoulder is oriented so that
30 the thrust bearing assembly, when mounted thereon, will be sandwiched between the two elements and disposed around the axis. With the curved cross-section of the spring washer having a convex side and a concave side, the spring washer is disposed so that the convex side faces the thrust bearing and the concave side faces one of the two elements.

It is desirable for the concave side of the spring
35 washer to directly contact the element it faces. It may be desirable, in some applications, for an intermediate structure (e.g., some type of a washer) to be disposed between the concave side of the spring washer and the element it faces. It is also

desirable for the spring washer to be compressed so as to preload the thrust bearing between the two elements.

The mechanism of the present apparatus can be a transmission such as, for example, a continuously variable
5 transmission. The mechanism can also be separate portions of a transmission such as, for example, a co-axial drive, a single- or dual-cavity toroidal drive or an output gear section.

The objectives, features, and advantages of the present invention will become apparent upon consideration of the
10 description herein and the appended drawings.

BRIEF DESCRIPTION OF THE DRAWINGS

Fig. 1 is a broken-away partially sectioned side view of the front end of one embodiment of the co-axial drive transmission of the present invention, with the dual cavity
15 toroidal type continuously variable drive and the co-axial planetary drive revealed;

Fig. 2 is a broken-away partially sectioned side view of the rear end of the transmission of Fig. 1, with the output gear section revealed;

20 Fig. 3 is a schematic top view of the transmission of Figs. 1 and 2;

Fig. 4 is a partially broken away sectional end view taken along lines 4-4 through the forward cavity of the toroidal drive of Fig.1;

25 Fig. 5 is a sectional side view taken along lines 5-5 of Fig. 4;

Fig. 6 is a partially broken-away and sectioned top view of only the toroidal drive of Fig. 1, with the front end of the housing removed;

30 Fig. 7 is an enlarged sectional side view of one traction trunnion/roller assembly and control piston assembly used in the toroidal drive of Fig. 1;

Fig. 8 is an enlarged sectional side view of one spring loaded check valve that can be used in the control piston
35 assembly of Fig. 7;

Fig. 8A is a sectional end view of one spring loaded check valve of Fig. 8 taken along lines 8A-8A;

Fig. 9 is a partially broken away bottom view of the train of phase gears used in the toroidal drive of Fig. 1, with the lower links of the trunnion linkage system;

5 Fig. 10 is a cross-sectional view of one embodiment of a thrust bearing assembly, according to the present invention, mounted between two elements (shown in phantom) of the co-axial drive of Fig. 1;

10 Fig. 11 is a plan view of the convex side of the washer-shaped thrust bearing spring forming part of the thrust bearing assembly of Fig. 10;

Fig. 12 is a cross-sectional view of the washer-shaped thrust bearing spring of Fig. 11 taken along lines 12-12; and

Fig. 13 is an enlarged view of the cross-section of the washer-shaped thrust bearing spring of Fig. 12.

15 DETAILED DESCRIPTION OF THE INVENTION

Although the present invention is herein described in terms of a specific embodiment, it will be readily apparent to those skilled in this art that various modifications, re-arrangements, and substitutions can be made without departing
20 from the spirit of the invention. The scope of the present invention is thus only limited by the claims appended hereto.

Referring to Figs. 1-3, one embodiment of a continuously variable transmission (CVT) 10 according to the principles of the present invention is an infinitely variable
25 and regenerative transmission which includes a forward positioned continuously variable drive 12 interconnected by a co-axial drive 16 to a rearward positioned output gear section 14 (see Figs. 2 and 3) such as that disclosed in the U.S. Patent Application Serial No. 08/372,771, filed January 13, 1995 and
30 entitled CO-AXIAL DRIVE FOR A TOROIDAL DRIVE TYPE TRANSMISSION, which is assigned to the assignee of the present application and incorporated in its entirety herein by reference. For purposes of clarification, the terms front or forward refer to the left side and rear or rearward refer to the right side of the views
35 shown in Fig. 1. The elements 12, 14 and 16 of the CVT 10 are enclosed in a housing 19 and driven off of a main or input drive shaft 18 powered from an engine (not shown). The housing 19 has three chambers, one for each element 12, 14 and 16 of the

exemplary CVT 10, that are separated by walls 20 and 21. A shaft support bracket 17 is mounted at its ends to the inside of the housing 19 to provide support for shaft 18 in the forward housing chamber containing drive 12. The main shaft 18 is mounted with bearings for rotation through a hole formed in the center of the bracket 17. The co-axial drive 16 is a planetary type drive. The drive 12 is a dual cavity toroidal type continuously variable drive, shown as being off-center in this embodiment. It is understood that co-axial drive 16 can be varied in a number of ways including being an epicyclic (as shown) or conventional planetary gear assembly or a type of planetary traction drive. It is also understood that toroidal drive 12 can be varied in a number of ways including being an off-center toroidal drive (as shown) or an on-center toroidal drive. The structure of toroidal drive 12 will initially be disclosed in general to describe its interaction with the co-axial planetary 16.

The dual cavity toroidal drive 12 includes first and second outboard traction disks 22 and 23, and two inboard traction disks formed as one integral element 24 all mounted on shaft 18. Inboard disks 24 are preferably a dual-faced single disk element, as shown. However, inboard disks 24 can also be two separate disks which are positioned back-to-back and simply coupled together in a conventional manner to react in unison. An example of a dual cavity toroidal drive having dual inboard disks is disclosed in U.S. Patent No. 5,368,529, which is incorporated in its entirety herein by reference. A toric cavity is defined between each outboard disk 22 and 23 and the inboard disk element 24. A pair of traction trunnion/roller assemblies 13 are disposed in each toric cavity. Each trunnion/roller assembly 13 includes a motion transmitting traction roller 25. The assemblies 13 are mounted so that one roller 25 is disposed transversely on either side of each cavity (see Figs. 3-6). Each pair of traction rollers 25 are mirror images of the other pair; therefore, only the one pair of rollers 25 are illustrated herein. Each pair of traction rollers 25 are engaged between the inboard disk element 24 and one of the outboard disks 22 and 23 in circles of varying diameters depending on the transmission ratio. The rollers 25

are so supportive that they can be moved to initiate a change in the transmission ratio. That is, each roller 25 can be actuated to vary its diameter and provide a substantial normal force at their points of contact with the corresponding disks to sufficiently support the traction forces needed to effect the change in transmission ratio. With shaft 18 being rotated continuously by an engine (not shown), the outboard disks 22 and 23 impinge on the traction rollers 25, causing the traction rollers 25 to rotate. As they rotate, the traction rollers 25 impinge on and rotate the inboard disk element 24 in a direction opposite to that of the rotating outboard disks 22 and 23. The structure and operation of the other elements of the toroidal drive 12, including the traction disks 22-24 and the traction rollers 25, will be discussed in greater detail later on in the specification.

First outboard disk 22 is seated against a forward positioned stop lip 26 formed circumferentially around shaft 18 and is splined at interface 28 for rotation with a section of shaft 18 located rearward of lip 26. Inboard disk element 24 is mounted between outboard disks 22 and 23 on roller bearings 30 which allow rotation around shaft 18. The rearward end of the inboard disk element 24 is splined for rotation with a first torque tube 32 which is adapted and disposed for rotation around shaft 18. First tube 32 is disposed concentrically through and adapted to rotate relative to the second outboard disk 23. The rear ends of the first torque tube 32 and the second outboard disk 23 are disposed through an axial opening in the housing wall 20 and into the middle chamber of housing 19 containing the co-axial planetary 16. The rear end of the second outboard disk 23 has a collar 33 extending rearward therefrom which is mounted for rotation in the axial opening with roller bearings 35.

Integral with the rearward end of the first tube 32 is a first sun gear 34 forming an input of the co-axial planetary 16. The epicyclic planetary 16 also includes a first planetary carrier 36 for carrying three pairs of axially joined first and second planet gears 38 and 40 around shaft 18. Preferably, each pair of compound planet gears 38 and 40 is of one-piece construction. Epicyclic planetary 16 does not include a ring gear, as is typically present in conventional planetary

gear assemblies. Carrier 36 includes a circular support arm or flange 42 disposed around and splined at interface 44 for rotation with the rear end collar 33 of the second outboard disk 23. The outer race of roller bearings 35 is sandwiched between
5 and in contact with the second outboard disk 23 and the carrier flange 42. Another circular support arm or flange 46 is spaced rearward from flange 42 and includes a collar 48 mounted for rotation in an opening formed through wall 21 and around shaft 18. The support flanges 42 and 46 are fixed relative to one
10 another by three sets of a bearing pin 50 and a spacer block 52. The bearing pins 50 and spacer blocks 52 are equally and alternately spaced around shaft 18. In addition, each bearing pin 50 and its corresponding spacer block 52 are disposed directly across from each other on opposite sides of shaft 18
15 and rigidly fixed at their ends to flanges 42 and 46. All three spacer blocks 52 are an integral part of and disposed around a central carrier hub 54 splined at interface 55 for rotation with the main shaft 18. The hub 54 of planetary carrier 36 is axially seated forward of and against a stop 56, such as a
20 retainer clip or split ring fixed in a circumferential groove, on shaft 18.

The traction disks 22-24 of the dual cavity toroidal drive 12 and the co-axial planetary 16 are held axially between stop lip 26 and retainer clip 56 so that the axial thrust that
25 is put on the second outboard traction disk 23 is eventually reacted upon by the main shaft 18. Also, in this way, relative axial movement between the various components of the toroidal drive 12 and epicyclic planetary 16 is substantially limited. Consequently, relative movement between the various components
30 of the drive 12 and planetary 16 is substantially only rotational in nature. Having the inboard disks and the outboard disks coupled together and pinned together in this manner eliminates the need for using axial load bearings with each of the disks. While some type of radial bearings are required, the
35 radial loading is usually limited to gear separation loads and gravity loading. Such radial bearings, therefore, do not account for any great power losses. On the other hand, axial force loads on traction disks are almost always large. Therefore, by eliminating the need for axial bearings, a major

source of power loss can be eliminated. For this reason, the dual cavity design is preferred.

Each pair of planet gears 38 and 40 is mounted on one bearing pin 50 with roller bearings to allow rotation therearound. The first or forward planet gear 38 of co-axial planetary 16 is engaged with the input sun gear 34 on the rear end of torque tube 32, and the second or rearward planet gear 40 is engaged with a second sun gear 58 forming an output of the co-axial planetary 16. The output sun gear 58 is smaller than the input sun gear 34 and is splined at interface 60 for rotation with the forward end of a second torque tube 62 extending into sun gear 58. The rearward end of the second tube 62 extends through the collar 48 of support flange 46 and through the opening in the wall 21 to the rearmost chamber of housing 19 containing an output gear section 14 of the CVT 10.

Referring to Figs. 2 and 3, integral with the rearward end of the second torque tube 62 is a third and fourth sun gear 64 and 66 forming the input of a mode one planetary gear assembly 68 and a mode two planetary gear assembly 70 of the output gear section 14, respectively. The mode one planetary 68 is a mixing or summing planetary disposed rearward of the mode two planetary 66 which is a speed reducer and reverser planetary. The mode one planetary 68 includes a planetary carrier 72 for carrying three planet gears 74 around input shaft 18, and an outer annular or ring gear 76. The third sun gear 64 is engaged with the three planet gears 74, which are each engaged with the ring gear 76. Ring gear 76 is fixed to the outer edge of a circular support flange 77 having a collar 79 splined at interface 81 for rotation with shaft 18.

Carrier 72 includes three bearing pins 78 and three spacer blocks 80 that are rigidly fixed at their ends between two circular support flanges 82 and 84 disposed around shaft 18. Each planet gear 74 is mounted on one bearing pin 78 using roller bearings to allow rotation therearound. The pins 78 and blocks 80 are equally and alternately spaced around shaft 18. Each bearing pin 78 and its corresponding spacer block 80 are also disposed directly across from each other on opposite sides of the shaft 18. Flange 82 is disposed rearward of flange 84 and extends from the pins 78 and blocks 80 radially toward the

shaft 18 where it is axially trapped between a pair of bearings 86, yet free to rotate around shaft 18. Flange 84 extends from the pins 78 and blocks 80 radially outward with an outer edge splined at interface 88 for rotation with an inner tube 90.

5 The inner tube 90 extends over the top of the ring gear 76 towards the rear or output end of the transmission 10. At its rearmost end, the tube 90 is splined at interface 92 for rotation with a conventional clutch plate assembly 94. Clutch 94 is splined at interface 93 for direct rotation with an output
10 drive shaft 95 through a clutch retainer 97 in a conventional manner. Therefore, the operation of output gear section 14 between clutch 94 and output shaft 97 will not be described in detail herein. The rear end of input shaft 18 is fit with a bushing 99, allowing rotation in a bore formed in the forward
15 end of output shaft 95. Output shaft 95 is interconnected in a conventional manner to an axle mounting a pair of wheels on a vehicle (not shown).

 The mode two planetary 70 is a simple planetary with a fixed planetary carrier 100 for carrying three planet gears
20 102 around shaft 18, and an outer annular or ring gear 104. Carrier 100 includes three bearing pins 106 and three spacer blocks 108 that are rigidly fixed at their ends between a carrier bracket 110 and a circular carriage flange 112. Carrier bracket 110 and carriage flange 112 are each disposed around
25 shaft 18. The carrier bracket 110 is fixed to wall 21, such as with bolts, and the circular carriage flange 112 hangs off of bracket 110 with a cradle collar 114. Each planet gear 102 is mounted on one bearing pin 106 using roller bearings to allow rotation therearound. The pins 106 and blocks 108 are equally
30 and alternately spaced around shaft 18. Each bearing pin 106 and its corresponding spacer block 108 are also disposed on opposite sides of the shaft 18. Ring gear 104 is fixed to the outer edge of a circular support flange 116 which is axially trapped, yet free to rotate around shaft 18, between a pair of
35 bearings mounted on the cradle collar 114.

 The fourth sun gear 66 is engaged with the three planet gears 106, which are each engaged with the ring gear 104. Ring gear 104 is splined at interface 118 for rotation with an outer tube 120. The tube 120 extends over the top of the mode

one planetary 68 towards the rear or output end of the transmission 10. At its rearmost end, the tube 120 is splined at interface 122 for rotation with a conventional clutch plate assembly 124, located forward of clutch 94. Clutch 124 is also splined at interface 93 for direct rotation with output drive shaft 95 through clutch retainer 97 in a conventional manner. Therefore, which planetary 68 or 70 transmits power to output shaft 95 depends on which clutch 94 or 124 is engaged, respectively.

It is desirable for all of the gears used in the coaxial planetary 16 as well as those used in the output gear section planetaries 68 and 70 to be helical gears. A spring loaded thrust bearing assembly 11, according to the present invention, can be used in a number of mechanisms such as, for example, the continuously variable transmission or CVT 10. There are numerous embodiments of the present thrust bearing assembly 11. One embodiment of the assembly 11, shown in Fig. 10, includes a thrust bearing 27 sandwiched between two thrust washers 29 and 31, with a washer-shaped load bearing spring or spring washer 15 positioned against one of the washers 29 or 31.

It is desirable for the thrust bearing 27 to be a conventional needle thrust bearing that includes a plurality of circumferentially spaced needle rollers 37 mounted within an annular housing or cage 39 so that each roller 37 is rotatable about its longitudinal axis. The longitudinal axis of rotation of each needle roller 37 extends radially out from the axis of rotation 41 of the thrust bearing 27. Thus, each needle roller 37 has an outer end 43 adjacent the outer diameter of the roller cage 39 and an inner end 45 adjacent the inner diameter of the roller cage 39. By using needle rollers 37, the present thrust bearing assembly 11 can take up less space than other types of thrust bearings. At the same time, the thrust bearing assembly 11 significantly reduces, if not eliminates, the losses and friction generated heat associated with the slippage that occurs at each end of the needle rollers 37.

The spring washer 15 is made, for example, from a suitable spring steel and has a curved cross-section that is operatively adapted so as to direct a normal load more toward the middle of each needle roller 37 than toward its ends. The

cross-section of the spring washer 15 can have a single radius of curvature such as, for example, the circular curvature shown in Figs. 10, 12 and 13. Alternatively, it is believed that the spring washer 15 can have a multiple radii curvature such as, for example, an elliptical curvature. The exemplary spring washer 15 has substantially the same cross-sectional curvature around its entire circumference. The thrust washers 29 and 31 are conventional thrust washers made, for example, from a suitable bearing steel.

Referring to Figs. 11-13, the curved cross-section of the exemplary spring washer 15 has a convex side 47 and a concave side 49. The convex side 47 faces the thrust bearing 27 and, in the illustrated embodiment, contacts the washer 29. The convex side 47 has a substantially coplaner inner and outer diameter edge 51 and 53, respectively. The inner and outer edges 51 and 53 are considered substantially coplaner when they both make contact with an element (e.g., the central carrier hub 54) or a thrust washer disposed therebetween. For example, it is envisioned that either or both of these edges 51 and 53 could be wavy so that the spring washer 15 only makes contact with the element 54 at spaced locations along the circumference of either or both of its inside and outside diameters. The cross-section of the spring washer 15 forms an apex or crown, between the edges 51 and 53, which defines a contact circle or ring 57. The spring washer 15 is mounted, relative to the thrust bearing 27, so that the contact circle 57 bisects each needle roller 37 about halfway along the length of each needle roller 37. In other words, the spring washer 15 is disposed so that its contact circle crosses over about the midpoint of each needle roller 37. The contact circle 57 of the exemplary spring washer 15 can be at least substantially continuous rather than continuous as shown. That is, the spring washer 15 forms a contact circle that is sufficiently continuous that the spring washer 15 loads each needle roller 37 substantially the same as the rollers 37 roll. For example, if a thrust washer 29 is disposed between the thrust bearing 27 and the spring washer 15 (as shown), the apex of the convex side 47 can be a series of spaced ridges or other protrusions which contact the washer 29 and generally define a circle in shape.

In a modification to the exemplary thrust bearing assembly 11, the thrust washer 29 is removed and the convex side 47 of the spring washer 15 directly contacts the needle rollers 37 of the thrust bearing 27. In a further modification, both
5 of the thrust washers 29 and 31 are removed. Thus, force can be transmitted directly between the needle rollers 37 and the spring washer 15, by the contact circle 57 of the spring washer 15 contacting the needle rollers 37, or indirectly through a thrust washer 29 disposed therebetween. It is understood that
10 the spring washer 15 may be positioned on the either side of the thrust bearing 27. The exemplary thrust bearing assembly 11 can also be modified by disposing a spring washer 15 on each side of the thrust bearing 27. Each spring washer 15 may be in direct contact with the needle rollers 37 or a thrust washer may
15 be disposed between one or each spring washer 15 and the needle rollers 37.

It is desirable for the present spring washer 15 to flatten under an applied axial load (i.e., a load applied along the axis 41). In this way, as the applied load increases, the
20 contact area between the spring washer 15 and the needle rollers 37 (either directly or indirectly through a thrust washer) will increase. As the contact area of the spring washer 15 increases, the capacity of the thrust bearing assembly 11 also increases. It is also desirable for this contact area of the
25 spring washer 15 to be evenly distributed on both sides of the midpoint of each needle roller 37. Thus, the present thrust bearing assembly 11 can be a dynamic bearing assembly.

A thrust bearing assembly, according to the present invention, can be used wherever the reference numeral 11 is
30 indicated in Figs. 1 and 2. The exemplary thrust bearing assembly 11 is shown in Fig. 10 mounted around the input drive shaft 18 between the central carrier hub 54 and the sun gear 34 of the CVT 10 (shown in phantom). The assembly 11 is seated on an annular shoulder forming part of, for example, the central
35 carrier hub 54. The axis of rotation 41 of the thrust bearing is aligned with the central axis of the drive shaft 18.

Satisfactory results have been obtained using an assembly 11 having the thrust washer 31, the needle thrust bearing 27 and the spring washer 15 (i.e., the assembly 11 of

Fig. 10 without the thrust washer 29). The spring washer 15 is compressed (i.e., flattened) so as to preload the thrust bearings 37 by about 50 pounds (222.4 Newtons) of force. The thrust washer 31 is a conventional thrust washers made from bearing steel and having a thickness of about .032 inches. One spring washer 15, that has produced satisfactory results when used with the CVT 10, is as shown in Figs. 11-13 and made from spring steel having a thickness of about .010 inches (.0254 cm). One example of this spring washer 15 has an inside diameter D_I of about 1.710 inches (4.343 cm), an outside diameter D_O of about 2.460 inches (6.248 cm), a radius of curvature R_C of about 1.179 inches (2.995 cm) and an overall crown height C_H of about .025 inches (.0635 cm). Another example of this spring washer 15 has an inside diameter D_I of about 2.033 inches (5.164 cm), an outside diameter D_O of about 2.663 inches (6.764 cm), a radius of curvature R_C of about .837 inches (2.126 cm) and an overall crown height C_H of about .025 inches (.0635 cm). A further example of this spring washer 15 has an inside diameter D_I of about 2.930 inches (7.442 cm), an outside diameter D_O of about 3.650 inches (9.271 cm), a radius of curvature R_C of about 1.094 inches (2.779 cm) and an overall crown height C_H of about .025 inches (.0635 cm).

The Toroidal Drive

The toroidal drive 12 used in this embodiment is a dual cavity design with the co-axial planetary 16 mounted at its rear and bisecting the shared reactions of the outboard disks 22 and 23. This allows the single piece inboard traction disk element 24 to be used instead of two separate inboard disks. The output of the inboard disk element 24 is transmitted through torque tube 32 which is concentric to the input shaft 18 and the rear most outboard disk 23. Since there is no parallel shafting, bearings mounted along the input axis (i.e., the central longitudinal axis of shaft 18) are for gravity and bounce loading only.

Referring to Figs. 4-7, each trunnion/roller assembly 13 includes an end supported trunnion 125. The toroidal drive 12 includes two end supported trunnions 125 disposed in each toric cavity, with one trunnion 125 being disposed transversely

on either side of each cavity (see Figs. 3-6). Each pair of trunnions 125 are mirror images of the other pair; therefore, only one pair of trunnions 125 are illustrated in an end view herein. One of the traction rollers 25 is mounted for actuation in each of the trunnions 125 in a manner described in detail below. Each trunnion 125 is mounted in anti-friction bearings 127 and 128 for free rotation at its top end and bottom end, respectively. It is desirable for each bearing 127 and 128 to be a needle bearing with needle rollers. The longitudinal axis of each needle roller is generally parallel with the longitudinal axis of the corresponding trunnion 125. A linkage system 126, as described directly below, mounts the bearings 127 and 128, supports the trunnions 125, and is adapted to allow each trunnion 125 to freely move axially, for example, in a substantially vertical plane and rotate about its central longitudinal axis. The trunnions 125 are the end supported type that enable the transmission to be controlled by translating the trunnion axially (e.g., up and down).

The top end and bottom end of each trunnion 125 are machined to form an upper and lower post 115 and 117, respectively, each having a slightly rectangular cross section and chamfered corners. An upper and lower bushing 119 and 121 is respectively disposed between the top and bottom bearings 127 and 128 and the upper and lower posts 115 and 117 of each trunnion 125. Each bushing 119 and 121 has a circular outer surface in direct contact with bearings 127 and 128, respectively, with a rectangular hole formed through its center for receiving one post. The rectangular cross section of each post 115 and 117 is adapted to snugly fit in the rectangular hole of its corresponding bushing 119 and 121 only along two opposing sides. In this way, each trunnion 125 (i.e., at its posts 115 and 117), and therefore its corresponding traction roller 25, is able to slightly slide back and forth in its respective bushing 119 and 121, as evidenced by the gap 123 shown on either side of the posts 115 and 117 in Figs. 5 and 6.

Deflections and manufacturing errors in the transmission can cause a difference between the theoretical or nominal center and the actual center of each toric cavity. Such differences can cause or contribute to imbalances in the load

shared by the rollers, resulting in the rollers running at different ratios. The side-to-side adjustability of the trunnions 125 is sufficient to allow the corresponding rollers 25 to move enough to compensate for differences between the nominal and actual center of each toric cavity. That is, the gaps 123 at the top and/or bottom of each trunnion 125 enable the rollers 25 (i.e., the trunnions 125) to be adjusted for a mismatch between the nominal position of the trunnions 125 and the toric cavity center line (i.e., the center line of the disks 22-24). Without the ability to adjust for such misalignments, one contacting roller 25 and toric disk could be more heavily loaded than another, resulting in some of the support bearings 127 and 128 being more heavily loaded than they should be. Because of this structure, the present rollers 25 do not have to move back and forth across their corresponding trunnion 125 to compensate for such a mismatch, as has been done with prior trunnion/roller assemblies, such as that disclosed in U.S. Patent No. 5,547,432. Such trunnion/roller assemblies are more expensive and are not readily adaptable to other trunnion/roller assembly designs, such as the lever action design of the present assemblies 13.

The trunnions 125 are supported relative to one another within the first chamber of the housing 19 by the present linkage system 126. The linkage system 126 connects the two cavities of the toroidal drive 12 such that the longitudinal reaction of one cavity is balanced by that of the second cavity. One example of the present linkage system 126 includes two top side links 130 and 131 that are transversely spaced on either side of the first housing chamber and two bottom side links 132 and 133 that are similarly spaced therebelow. The two top side links 130 and 131 and the two bottom side links 132 and 133 are joined at their front and rear ends by a top and bottom front cross link 134 and 135 and a top and bottom rear cross link 136 and 137, respectively. Each of the cross links 134-137 cross the toroidal drive 12 at about right angles to the longitudinal or input axis of the shaft 18.

One of the top and bottom trunnion bearings 127 and 128 is mounted at each end of the top and bottom side links 130-133, respectively. In addition, the front and rear ends of each

of the side links 130-133 are mounted in front and rear end or link bearings 139 and 141, respectively. One front end bearing 139 is mounted at each end of each front cross link 134 and 135, and one rear end bearing 141 is mounted at each end of each rear cross links 136 and 137. The end bearings 139 and 141 enable the trunnions 125 to move up and down, while the trunnion bearings 127 and 128 enable each trunnion 125 to rotate about its central longitudinal axis.

For a single cavity toroidal drive (not shown), each side link 130-133 could be shortened so that the resulting linkage system fits into the one toric cavity. Each of the shortened side links 130-133 would mount only one of the trunnion bearings 127 and 128. For example, one of the trunnion bearings 127 and 128 could be mounted halfway along the length of each shortened side link 130-133. The cross links 134-137 could remain the same and still be mounted in the same manner at the ends of the shortened side links 130-133. Alternatively, a single upper cross link and a single lower cross link could be used as structural equivalents to the two upper cross links 134,136 and the two lower cross links 135,137. Each of these single cross links could have forked ends with one of the shortened side links being mounted between opposing prongs of each forked end.

It is believed that satisfactory results can be obtained using any type of rolling element bearing or even a plane bearing (e.g., a bushing) for each of the trunnion bearings 127 and 128 and the end bearings 139 and 141. It is desirable for each end bearing 139 and 141, in addition to each trunnion bearings 127 and 128, to be a needle bearing with needle rollers. The longitudinal axis of each needle roller in the end bearings 139 and 141 is generally parallel with the longitudinal axis of the corresponding side link 130-133.

Each of the lower cross links 135 and 137 has a central support or pivot pin 143 mounted thereon. Each lower pin 143 is seated in the opening or notch of a fork 145 formed on the inside of the housing 19. The forks 145 are disposed inboard of the lower cross links 135 and 137. A compression spring 144 (e.g., a coil spring) is mounted in a vertically oriented bore hole formed in each fork 145, underneath each

support pin 143 (see Fig. 1). Each compression spring 144 is designed with a sufficient length and spring force to maintain a gap 143b between each support pin 143 and the bottom of the notch of the corresponding fork 145. The shaft support bracket 17 is seated within the notch of the forward fork 145 so as to form a gap 143a above the forward support pin 143. In this way, movement of the support pin 143 is constrained.

In an exemplary modification of the illustrated linkage system 126, the springs 144 are mounted under the pins 146, under one of the pins 143 in one toric cavity and one of the pins 146 in the other toric cavity, under all of the pins 143 and 146, or any other suitable combination thereof. In another modification of the illustrated linkage system 126, each of the pins 143 and 146 is fixed in its corresponding bracket 17, bracket 142 or fork 145. The holes where the pins 143 and 146 are shown mounted in the cross link 134-137 (see Fig. 1) are opened up to form the gaps 143a and 143b above and below each of the pins 143 and 146. One spring 144 is then mounted in a vertically oriented bore hole formed in each cross link 134-137, above each of the pins 143 and 146.

Springs have been used in the past to support prior art trunnion/roller assemblies and their linkage system. However, it has been found that the springs in such prior art linkage systems could be caused to bottom out (i.e., coil binding) by the weight of the trunnion/roller assemblies and their linkage system, and the trunnion/roller assemblies could be moved off center, such as from an external event like hitting a pot hole. After being bottomed out or otherwise over-compressed enough times, a spring can lose its strength. Such a loss in spring strength can cause the corresponding trunnion/roller assemblies of prior art linkage systems to become misaligned within their corresponding toric cavities. By positioning the notch of a fork 145 a limited clearance (i.e., gap 143b) below each pin 143, the downward motion of each lower cross link 135 and 137 (i.e., each trunnion/roller assembly 13) is limited accordingly. Thus, for the illustrated embodiment, the notches of the forks 145 act as positive stops (i.e., provide stop surfaces) to prevent the trunnion/roller assemblies 13 from bottoming out or over-compressing the springs

144. Because of the positive stops provided by the forks 145, the springs 144 are also more likely to maintain their strength and keep the trunnion/roller assemblies 13 aligned properly.

The positive stops provided by the forks 145 enable
5 compression springs 144 to be used which have a flat or a low spring rate (i.e., spring constant). With a flat spring rate, the spring force stays about the same over the range that each spring deflects. With a low spring rate, the spring force only changes a small amount over the spring deflection range. With
10 a flat or low spring rate, the springs 144 compensate for the weight of the trunnion/roller assemblies 13 and their linkage system 126 and do not substantially determine the position of the rollers 25 relative to the toric disks 22-24. The compression springs used in prior linkage systems have had high
15 spring rates. With a high spring rate, the spring force changes a relatively large amount over the spring deflection range. Thus, such prior compression springs not only compensate for the weight of the corresponding trunnion/roller assemblies but also substantially affect the position of the rollers relative to the
20 toric disks.

The springs 144 are strong enough to balance the weight of the trunnion/roller assemblies 13 and their linkage system 126. In addition, the spring rate of each spring 144 is low enough to enable the hydraulic forces provided by the ratio
25 control assembly 179 (discussed further below) to deflect the corresponding spring 144 enough to keep the trunnion/roller assemblies 13 centered within their respective toric cavity and, thereby, maximize the efficiency of the toroidal drive 12. Because of their high spring rates, the springs used in prior
30 linkage systems have to be sized and positioned with a much higher degree of accuracy than the present springs 144 in order to keep their corresponding trunnion/roller assemblies centered within their respective toric cavity.

At least the forward upper cross link 134 also has a
35 central support or pivot pin 146 mounted thereon which extends into a slightly oblong hole 148 formed in the shaft support bracket 17. The major axis of the oblong hole 148 is vertical to form a gap 146a above and a gap 146b below the pin 146. The gaps 146a and 146b allow slight vertical movement of the pin 146

therein, and thus the trunnions 125. If desired, the rearward upper cross link 136 can also be mounted with another support pin 146 so as to extend into another slightly oblong hole 148 formed in an optional hanger bracket 142.

5 The gaps 143a, 143b, 146a and 146b allow the linkage system 126 (i.e., all of the trunnions 125) to move up and down as a whole, for example, to compensate for errors in the manufacturing of the toroidal drive 12. At the same time, these gaps are small enough to constrain and prevent excess motion of
10 the trunnion/roller assemblies 13, such as from an external event like hitting a pot hole. The part of the brackets 17 and 142 forming holes 148, the notches of the forks 145 and the bottom of the bracket 17 function as positive stops in preventing the present linkage system 126 and the
15 trunnion/roller assemblies 13, as a whole, from moving a substantial amount vertically out of center with the toric cavities. That is, the vertical movement of the assemblies 13 is limited enough to prevent, or at least significantly inhibit, offsetting and roller fighting. For example, for the CVT 10,
20 these positive stops keep the present linkage system 126 and assemblies 13 centrally located around the axis of the main shaft 18. The gaps 143a, 143b, 146a and 146b are shown oversized for clarity. The gaps on either side of each pin 143 and 146 can have different lengths or the same length.

25 These pin supports 143 and 146 also help to prevent both of the trunnions 125 in one cavity from moving together up or down (i.e., offsetting) in the same direction more than the negligible amount permitted by each oblong hole 148, the forks 145 and the bottom of the bracket 17. In prior art toroidal
30 drives, inadvertent offsetting could occur from gravity or bounce loading, caused by an external event like hitting a pot hole. Offsetting of two trunnions in the same cavity in the same direction is undesirable because it causes opposite steering vectors on the rollers and scuffing or scrubbing of the
35 traction surfaces between the rollers and the disks (i.e., roller fighting). The pins 143 and 146 are prevented from moving in the horizontal direction (i.e., transversely from side-to-side) to help prevent one roller 25 from extending more than the opposite roller 25 in the same toric cavity.

Furthermore, two locators are used to maintain the linkage system 126, and thereby the toroidal drive 12, longitudinally in position within the forward chamber of housing 19. One of these locators includes loosely constraining the lower cross links 135 and 137 and the upper cross links 134 and 136 in the longitudinal direction (i.e., along the axis of the shaft 18) by contact with the corresponding forks 145 (i.e., housing 19) and the brackets 17 and 142. The other locator is supplied by bolting a rectangular block 149 to the underside of each of the lower side links 132 and 133 and by mounting a constraining pin 150 in the housing 19 above each of the upper side links 130 and 131 (see Figs. 5 and 6). One oblong slot 151 is formed in the housing 19 for receiving each block 149. Each slot 151 has its major axis oriented transversely (i.e., perpendicular to the axis of rotation of the shaft 18). Each block 149 is movable up and down and transversely within its corresponding slot 151. Each constraining pin 150 is disposed in a transversely oriented slightly oblong slot 152 formed through each of the upper side links 130 and 131. Each side link 130 and 131 is able to slide up and down its corresponding pin 150. The slot 152 illustrated in Fig. 6 is shown oversized for clarity. Thus, the side links 130-133 can move transversely within the slots 151 and 152 while being constrained longitudinally.

There may be a certain degree of redundancy in these longitudinal position locators. It may be possible to be limited to using only one or a combination of the lower cross links 135 and 137 and the forks 145; the upper cross links 134 and 136 and the brackets 17 and 142; the blocks 149 and slots 151; and the pins 150 and slots 152. One exemplary combination may be the use of the upper cross link 134 and the bracket 17 with the lower cross link 137 with its corresponding fork 145. The longitudinal clearance between the cross links 134-137 and the corresponding forks 145 and brackets 17 and 142 is typically larger than that allowed by the pins 150 and the slots 152 or the blocks 149 and the slots 151. These various locators locate the longitudinal position of the entire toroidal drive 12 since the disks 22-24 are otherwise free to float within the housing 19 along the longitudinal axis of the drive shaft 18. It may

also be desirable to use other portion of the CVT 10 to locate the longitudinal position of a particular linkage system.

The gaps 123 on either side of the posts 115 and 117; the gaps 146a and 146b above and below each pin 146; the gaps 5 143a and 143b above and below each pin 143; the gap in front of and behind each pin 150, formed by slots 152; and the gap on either side of each block 149, formed by the slot 151, are all sized within acceptable tolerances to maintain sufficient centering of the trunnion/roller assemblies 13 within the 10 corresponding toric cavities. Each of the gaps 123, the gap in front of and behind each pin 150, formed by slots 152, and the gap on either side of each block 149, formed by the slot 151, are also of sufficient size to allow for the transverse motion of the trunnions 125 caused by the trunnions 125 moving 15 vertically up and down (i.e., the cross links 134-137 pivoting about pins 143 and 146).

For the transmission 10, it is believed that satisfactory results can be obtained with the above gaps being in the following ranges. The inner side gaps 123 can be about 20 .005 inches (.127 mm) and the outer side gaps 123 about .030 inches (.762 mm) to prevent movement of the trunnions 125 toward each other. Thus, the gaps 123 do not have to be symmetrical. It is believed that the outer gap 123 can be up to about .050 inches (.127 cm). Each of the gaps 146a, 146b, 143a and 143b 25 can be in the range of about .010 to about .015 inches (.0254-.0381 cm). It is believed desirable for each of the gaps 143a, 143b, 146a and 146b to be in the range from about .010 inches to about .020 inches (.254-.508 mm). It is also believed that the gaps 143a, 143b, 146a and 146b can each be up to about .254 30 inches (1 mm), and possibly larger. The gap in front of and the gap behind each pin 150, formed by slots 152, can be up to about .030 inches (.762 mm) more than that needed to provide the trunnions 125 with a full range of up and down motion. The gap on either side of each block 149, formed by the slot 151, can 35 be open ended. It is believed desirable for the gap on either side of each pin 150 to be about .030 inches (.762 mm).

The cross links 134-137 sufficiently constrain the separating or transverse force between the two trunnions 125 in each cavity. At the same time, being interconnected by bearings

in the manner described above allows for a significant degree of freedom of movement with less friction while sufficiently supporting the trunnions 125. This is important because any stiction (i.e., intermittent sticking) or friction in the support of the trunnions 125 can lead to an upset in the balance of the control forces on the trunnions 125 (i.e., the forces exerted by the ratio control assembly 179, discussed further below) and hence an upset of the balance of the transmitted or tangential force on the trunnions 125 (i.e., the rubbing force between the corresponding traction rollers 25 and the disks 22-24), resulting in the rollers 25 running at slightly different ratios and fighting against each other. This roller fighting reduces the capacity of the drive.

Referring to Fig. 7, each trunnion/roller assembly 13 includes a lever assisted hydraulic piston assembly or roller loading assembly 147 mounted in each of the trunnions 125. Each roller loading assembly 147 includes a load piston 153 that exerts an axial loading force which provides the contact force between its corresponding roller 25 and disks 22 and 24 or 23 and 24 (i.e., the normal force for the traction contacts). Each roller loading assembly 147 maintains proper loading between the rollers 25 and the corresponding disks 22-24. It is desirable for each load piston 153 to be preloaded with one or more springs 155 so that each piston 153 applies an axial load force at all times, even without the axial hydraulic loading provided by the ratio control assembly 179 (discussed further below). Such a preload reduces the chance of the disks 22-24 slipping during the initial loading of the transmission 10 by maintaining a contact force between the rollers 25 and the corresponding disks 22-24. Satisfactory results have been obtained using a series of wave springs which provide a preload of about 150,000 psi mean Hertz pressure. It is believed that any type of spring system 155 can be used which applies an axial load on the piston 153 in the same direction as the axial hydraulic loading. For example, it is believed that the springs 155 can be any suitable dished spring.

When there is a torque running through the transmission 10 (i.e., the transmission 10 is loaded), the contact force is increased by extending the piston 153. Each

load piston 153 has an alignment shaft 157 extending out from the center of its face 159 and through a hole formed in the center of the corresponding traction roller 25. Each load piston 153 should push its roller 25 hard against the
5 corresponding disks 22 and 24 or 23 and 24 with sufficient force to prevent slippage along the interface between its roller and disks as the disks are rotating. The loading force from the piston 153 is amplified through a load lever disk 161 to maintain the high loads required. The load lever disk 161 has
10 a plurality of pie shaped levers 163 that are disposed around and that extend radially in toward the shaft 157 directly over the face 159. The levers 163 can be formed, for example, by making radial slits in the disk 161 or as separate levers kept together by some form of a retainer. Such load lever disks are
15 disclosed in U.S. Patent No. 5,299,987 which is incorporated by reference in its entirety herein. Each lever 163 is supported near its outer end by any suitable fulcrum structure 162. The inner end 165 of each lever 163 is in contact with the piston face 159.

20 It is desirable for each lever 163 to be chamfered at its inner end 165 (as shown in Figs. 4, 6 and 7) when the inner end is in contact with the shaft 157, as well as the piston face 159. It is believed that the ends 165 need not actually contact the shaft 157. Satisfactory results have been obtained with the
25 ends 165 of each lever 163 being beveled about 15° from the surface of the shaft 157. Beveling the ends 165 in this manner facilitates the ease of movement of the levers 163 as the shaft 157 extends.

30 A circular thrust plate 167 is disposed between each load lever disk 161 and its corresponding traction roller 25. The thrust plate 167 includes an alignment stud or collar 169 disposed around shaft 157 and in a hole 170 formed through the roller 25. The collar 169 is fixed relative to the roller 25 within the hole 170 by annular retainer 172 and the annular
35 shoulder 174. The retainer 172 and the shoulder 174 help to prevent a substantial amount of side-to-side movement between the collar 169 and the traction roller 25. If desired, a needle bearing or any other suitable bearing may be placed in the annular space portion of the hole 170 between the collar 169 and

the roller 25 to further limit such side-to-side movement. A plurality of bearing balls 171 are disposed between each traction roller 25 and its corresponding thrust plate 167, allowing the roller 25 to freely rotate around shaft 157 (i.e., the axis of rotation of the roller 25). The likelihood of needing a bearing in the annular space portion of the hole 170 may be reduced by using a contact ball bearing, with at least some transverse load carrying capability, for the bearing balls 171.

The shaft 157 helps to prevent the roller 25 from wobbling or rocking (i.e., asymmetrical loading of the lever disk 161 described below) and subsequent cocking or tilting of the piston 153 and the roller 25 during the operation of the trunnion/roller assembly 13. Such tilting can lead to instability. It is desirable for the shaft 157 to be thick enough to inhibit its deflection under loading. It is also desirable for a slip fit to be formed between the shaft 157 and the thrust plate. A slip fit refers to the shaft 157 being able to move in and out of the thrust plate 167 but not from side-to-side. The slip fit between the shaft 157 and the thrust plate 167 helps to prevent such wobbling and to keep the shaft 157 in a centered relation to the lever disk 161.

The roller 25 can be further stabilized within the trunnion 125 by forming a slip fit between an outer surface 168 of the thrust plate 167 and the trunnion 125. It is believed that such a slip fit between the thrust plate 167 and the trunnion 125 will provide additional stability to the roller 25 even without the structure of the alignment shaft 157 and the collar 169. It is desirable for the outer surface 168 to be of sufficient axial depth to substantially inhibit wobbling or tilting of the thrust plate 167 within the trunnion 125. It may also be desirable for the collar 169 of the thrust plate 167 to be in the form of a stud and for the load piston 153 not to have the alignment shaft 157.

In a modification of the trunnion/roller assembly 13, the alignment shaft 157 can be adapted to only partially extend into a through hole or blind hole formed in the roller 25. In another modification of the assembly 13, the piston 153, including its shaft 157, can have a bore hole formed

therethrough along its central longitudinal axis so that the shaft 157 has a tubular appearance. An alignment post can then be disposed within the bore hole, through the center of the springs 155 and fixed to the trunnion 125 so that the piston 153 and the shaft 157 can slide back and forth along the alignment post. Such an alignment post can provide additional stability, especially if a slip fit is not used between the thrust plate 167 and the trunnion 125.

The face 159 of each load piston 153 is beveled out from the shaft 157 so as to angle away from the roller 25. The face 159 of the piston 153 includes an annular or circular area 177 which curves radially from the shaft 157 and away from the roller 25. The ends 165 of the levers 163 contact and are acted upon by this annular area 177 of the piston 153. This area 177 has a radius of curvature that is controlled such that the lever ratio decreases as the piston 153 moves along the axis of its shaft 157 toward the roller 25. An area 177 having a radius of curvature of about 1.0 inch (2.54 cm) has produced satisfactory results when used with a toroidal drive having a center-to-center distance between two side-by-side toric cavities (i.e., a toroidal drive diameter) of about 7.75 inch (19.69 cm).

Below each trunnion 125 is a hydraulic control piston assembly or ratio control assembly 179 for controlling the transmission ratio of the toroidal drive 12 by vertically positioning the trunnion 125. Each ratio control assembly 179 includes a control piston 181 mounted on a shaft 183. The piston 181 vertically moves the shaft 183 up and down. The inside diameter of the piston 181 is sealed against the shaft 183 by two groove seated O-ring seals 180. The piston 181 is disposed in a cylinder 185 between a top cover 187, integral with cylinder 185, and a removable bottom cover 189. The cylinder 185 and the covers 187 and 189 define a space that is divided into an upper fluid chamber and a lower fluid chamber by the piston 181. The upper end of the mounting shaft 183 extends through an upper control seal bushing 191 disposed through a slightly oversized hole formed through the top cylinder cover 187. The lower end of the shaft 183 extends through a lower control seal bushing 193 disposed through a slightly oversized hole formed through the bottom cylinder cover

189.

Since the roller/trunnion assemblies 13 do not rotate about a fixed center, the control piston 181 must be free to move horizontally to eliminate any chance of binding. The oversized holes in covers 187 and 189 provide the control piston 181 with this freedom of movement. Each control bushing 191 and 193 is sealed against the inside surface of its corresponding cylinder cover 187 and 189 by a groove seated O-ring seal 195. If desired, leakage of hydraulic fluid from between the shaft 183 and the bushings 191 and 193 can be prevented by disposing an elastomeric seal (e.g., teflon rubber) therebetween, such as inside a circumferential groove 197 formed in each bushing 191 and 193.

The upper end of each mounting shaft 183 is snugly disposed inside an axial bore 196 formed in the lower end 117 of its corresponding trunnion 125. A washer seal 198, formed as an integral part of the shaft 183, is seated snugly around each mounting shaft 183, between a shoulder formed on the inside of the lower bushing 121 of the corresponding trunnion 125 and a shoulder formed in the mounting shaft 183, effectively sealing the hydraulic connection between the trunnion 125 and shaft 183. The outer diameter of the seal 198 is sized smaller than the shoulder on the lower bushing 121 so it can move sideways with the trunnion 125 and maintain the seal.

Each ratio control assembly 179 and the corresponding roller loading assembly 147 are hydraulically interconnected by a passageway 199 formed through the trunnion 125, passing axially through the mounting shaft 183 and splitting off into four circumferentially spaced passages fanning radially out through the control piston 181. Each of these four passages leads to a check valve 201 disposed vertically through the piston 181. Each control cylinder 185 is selectively linked hydraulically to its corresponding trunnion 125 by way of its four check valves 201. Both assemblies 147 and 179 are supplied with pressurized hydraulic fluid or oil by the same hydraulic loading system (not shown). One such hydraulic system is disclosed in U.S. Patent No. 5,540,631, filed October 7, 1994, issued July 30, 1996 and entitled CONTINUOUSLY VARIABLE TRANSMISSION WITH A HYDRAULIC CONTROL SYSTEM, which is assigned

to the assignee of this application and is incorporated herein by reference in its entirety.

Each check valve 201 can be a single action type, as shown in Fig. 5, with two of the four single action check valves 201 allowing hydraulic fluid to flow from only the fluid chamber above the piston 181 and the other two single action check valves 201 allowing fluid to flow from only the fluid chamber below the piston 181. It can be more desirable for each check valve 201 to be a double action check valve, such as that shown in Fig. 8, which allows hydraulic fluid to flow through the check valve 201 from above and below the piston 181. In an alternative embodiment, a ratio control assembly 179 could be mounted on either end of each trunnion 125. In such an embodiment, single action check valves 201 could be used on each end of the trunnion 125, with each control assembly 179 having check valves 201 that are oriented the same and with the check valves 201 at one end of the trunnion 125 being oriented opposite to the check valves 201 at the other end of the trunnion 125.

Regardless of whether single action or double action check valves 201 are used, it has been found most desirable for the check valves 201 to be spring loaded, for example, with a spring 202 as shown in Fig. 8. It has been found that the control assembly 179 can respond more quickly when each check valve 201 is spring loaded. A spring loaded check valve 201 has been found to be better able to prevent fluid communication between the chambers above and below the control piston 181. It has also been found that by being spring loaded, the check valves 201 will close before fluid pressure between the ratio control assembly 179 and the roller loading assembly 147 goes to zero. Maintaining positive fluid pressure, or at least preventing a loss of fluid (i.e., fluid voids), between the assemblies 179 and 147 allows for shorter response times in actuating the roller loading assembly 147. It is believed to be beneficial for a spring loaded check valve to be used in the trunnion/roller assembly disclosed in previously incorporated U.S. Patent No. 5,299,987, as well as in other trunnion/roller assemblies. In addition, while the check valves 201 can be ball valves, it is also more desirable for the check valves 201 to

be piston valves 204, for example, with one or more pistons as shown in Figs. 8 and 8A. One reason it is more desirable for each check valve 201 to use a piston seal 206 rather than a ball seal is because a ball seal is more likely to exhibit chattering and sealing problems.

The hydraulic pressure positions the vertical height of the trunnions 125 and, therefore, the rollers 25 between the disks 22-24. The pressure raises or lowers the rollers 25 relative to the disks 22-24. The rollers 25 are the torque reaction points between the input disks 22 and 23 and the output disk element 24. Each roller 25 acts like a caster, following the path of least resistance, and reacting to the forces at the contact points between the disk and roller. The result is a simple hydraulic system to control the transmission ratio at all times. In order to maintain a desired transmission ratio, the hydraulic pressure must exactly balance the torque being transmitted between the input disks 22 and 23 and the output disk element 24 at any given time. If the position pressure is too high, the toroidal drive 12 will up ratio. If the pressure is too low, the toroidal drive 12 will down ratio. The ratio of the control piston area of piston 181 to the load piston area of piston 153 and the load lever ratio of levers 163 will determine the ratio of the transmitted or rubbing force (i.e., the tangential force) to the contact force between the disks and rollers.

It has been found that the frictional forces associated with a linkage system used to mechanically link two or more trunnions together can have an impact on the ability of the corresponding toroidal drive to obtain and maintain a desired transmission ratio. If these frictional forces are not balanced between the linkage system and each trunnion, the rollers can end up driving the toric disks at different speeds causing an imbalance in the toroidal drive. Such imbalances can cause significant energy losses and increased wear and tear, which can lead to premature failure of the toroidal drive and the transmission. Excessive frictional forces in the linkage system can also cause or contribute to energy losses and increased wear and tear. Prior linkage systems with ball/socket joints have been found to be particularly susceptible to

exhibiting such imbalance problems, especially under prolonged heavy loading.

The present linkage system 126 is more likely to exhibit balanced frictional forces and, therefore, is less likely to experience such imbalance problems. In addition, the use of needle rollers in bearings 127, 128, 139 and 141 significantly reduces, if not eliminates, frictional forces in the corresponding joints connecting the trunnions 125, the side links 130-133 and the cross links 134-137. Prior trunnion linkage systems had one bearing system at either end of each trunnion that handled both the trunnion translation and rotation. One such prior bearing system included a ball/socket joint that handled the trunnion translation and some form of an anti-friction bearing that handled the trunnion rotation. With the present trunnion linkage system 126, two bearings 127 and 128, one at either end of each trunnion 125, handle the trunnion translation and two bearings 139 and 141, one at each end of the side links 130-133, handle the trunnion rotation.

There is a conventional spool valve (not shown) located in the housing 19 immediately below the toroidal drive 12. This spool valve modulates the hydraulic oil pressure to position the rollers 25. The spool valve maintains the proper pressure by receiving an input signal from two sources. The first source is a mechanical link to a variable reluctance electric motor (not shown) which positions the spool valve by actuating a lead screw. The electric motor is, in turn, controlled by a computer (not shown). The second input source to the spool valve is another mechanical link (a feedback link). The movement of the trunnions 125 affects the spool valve through the feedback link. If the rollers 25, via the trunnions 125, move up or down or rotate to a new ratio angle, the link moves the valve to boost or reduce the oil pressure to bring the toroidal drive 12 back to the desired ratio. To summarize, the computer selects the desired ratio via the electric motor, and the feedback link keeps the toroidal drive 12 at the ratio selected by the computer. To reduce pumping losses and improve efficiency, it has been found desirable to maintain a line pressure of about 25 psi above the required pressure to support the trunnions 125. A spring loaded spool valve is used to

maintain this pressure differential.

Referring to Fig. 9, to prevent the trunnions 125 from wandering grossly out of rotational phase with each other when the above described hydraulic loading system is inactive, the bottom ends of the trunnions 125 are interconnected by a train of phase gears. One end phase gear 203 is formed as the lower part of each lower trunnion bushing 121. Each end phase gear 203 is meshed with one of two other side link connecting phase gears 205. Each link connecting gear 205 is mounted for rotation on one of two side link arms 207 extending inward from each lower side link 132 and 133. The arms 207 are adapted so that each connecting gear 205 on one side link 132 is meshed with only one gear 205 directly opposite it on the other side link 133. Meshed between the two end gears 203 under each side link 132 and 133 are two meshed rotation limiting gears 208 and 209, used to limit the rotation of the gears in this train. Each limiting gear 208 and 209 is mounted for rotation with a bushing around one of the bolts used to secure the corresponding rectangular block 149 to the underside of its lower side link 131 and 133. A generally cross-shaped protrusion 210 extends down from the underside of each side link 131 and 133, between each pair of limiting gears 207 and 208. Each protrusion 210 extends down into a space provided by two opposing semi-circular shoulders 212, one shoulder 212 being formed around the axis of rotation in each limiting gear 207 and 208. Thus, each protrusion 210 prevents further rotation of its corresponding gears 207 and 208 when the end 214 of at least one shoulder 212 makes contact with the protrusion 210.

Operation of the CVT

In operation, the main shaft 18 of CVT 10 is rotated continuously by an engine (not shown). The rotation of shaft 18, in turn, directly rotates the first outboard traction disk 22, the hub 54 of planetary carrier 36 and the collar 79 of the mode one planetary ring gear 76, respectively through the splined interfaces 28, 55 and 81, all in the same direction. Rotation of the co-axial planetary carrier 36 causes the second outboard traction disk 23 to also rotate in the same direction as shaft 18. For the purpose of this description, rotation of

the shaft 18 will be referred to as being in a positive direction and any oppositely rotating element as being in a negative direction.

Rotating disks 22 and 23 impinge on and rotate the traction rollers 25. The traction rollers 25 then impinge on and cause the inboard traction disk element 24 to rotate in a negative direction. Inboard traction disk element 24 then rotates the first sun gear 34 of co-axial planetary 16 in a negative direction through torque tube 32. The rotational speed of the first sun gear 34 is relative to that of the planet carrier 36 and hence the planet gears 38 and 40. Thus, the planet gears 38 and 40 are rotated in a positive direction by the sun gear 34. Accordingly, second sun gear 58 is rotated in a negative direction by planet gear 40.

The mode one planetary 68 has two inputs, sun gear 64 and ring gear 76, and one output, flange 84. The negative rotation of the second sun gear 58 of epicyclic planetary 16 rotates the third and fourth sun gear 64 and 66 of the mode one and two planetaries 68 and 70 in the negative direction through the second torque tube 62, respectively. The ring gear 76 of planetary 68 is rotated in a positive direction by the engine through shaft 18. The positive and negative rotation of gears 76 and 64 causes the planet gears 74 to rotate in a positive direction. Even so, the positive and negative influence of ring gear 76 and sun gear 64 can add or subtract from each other and cause the carrier 72 of planetary 68 to rotate in a positive direction around shaft 18 when the influence of the ring gear 76 is greater, remain stationary when their influences balance each other or even rotate negatively when the influence of the sun gear 64 is greater. The sum of these two influences, whatever it is, is the output generated at the splined interface 88 leading to clutch 94. If clutch 94 is engaged, this output is then transmitted to output shaft 95 through clutch retainer 97. Output shaft 95 rotates in the same direction of rotation as the mode one carrier 72. In this way, the mode 1 planetary 68 functions as a summing or mixing planetary gear assembly, enabling output shaft 95 to be rotated in a positive or negative direction or kept stationary.

When planetary 68 is selected through clutch 94, the transmission 10 is in a regenerative mode. In the regenerative mode, some of the power that is transmitted from the engine, through shaft 18 and into ring gear 76 is siphoned-off and routed back to the second sun gear 58 of the co-axial drive 16 through planet gears 74 and sun gear 64. From the co-axial sun gear 58, this siphoned-off power is transmitted back to the main shaft 18 of the engine through the continuously variable drive 12 and the co-axial drive 16. How much power is siphoned-off is determined by the ratio or roller angle of the trunnions 125 in each toric cavity. How the trunnion angle of a dual cavity toroidal drive is changed is well known, does not form a basis for the present invention, and will not be discussed in detail herein.

As the rotation of the second co-axial sun gear 58 is affected, so too is the rotation of the sun gear 34 and carrier 36 through the pairs of planet gears 38 and 40. Changes in the rotation of carrier 36 affect the rotation of the main shaft 18 directly through hub 54 and indirectly through the toroidal drive 12 by directly affecting the rotation of the second outboard traction disk 23, and in turn, the first outboard traction disk 22. In this way, the CVT 10 exhibits a recirculatory power loop between the output gear section 14 and the continuously variable drive 12 through the co-axial drive 16. There is also a secondary power loop exhibited by the CVT 10 between the continuously variable drive 12 and the co-axial drive 16, through the co-axial carrier 36. This secondary power loop is slightly split torque and dominated by the recirculatory power loop.

If enough power is diverted away via the mode one sun gear 64, the carrier 72 will not rotate at all. This condition is often referred to as a geared neutral condition. If even more power is diverted away via sun gear 64, the rotation of carrier 72 will actually reverse and go opposite to the direction of rotation of ring gear 76. In this way, the transmission 10 is sent into reverse. The mode 1 planetary 68 can, therefore, send transmission 10 from a small reverse regime through a geared neutral or zero output speed and then into a forward speed. The forward speed of the mode one carrier 72 is

low. The mode 2 planetary 70 supplements the forward ratio of the mode 1 planetary 68 to enable greater forward speeds to be attained. When the maximum forward speed-up ratio of the mode one planetary 68 is reached, the transmission 10 is shifted from the mode one planetary 68 to the mode two planetary 70 by shifting from clutch 94 to clutch 124. The clutches are shifted by disengaging clutch 94 and engaging clutch 124, when the mode one carrier 72 rotates at the same speed as the mode two ring gear 104.

In the operation of the mode 2 planetary 70, power from shaft 18 is transmitted through co-axial drive 16 to rotate the sun gear 66 in a negative direction. Sun gear 66 rotates the planet gears 102 in a positive direction, which rotate the ring gear 104 in a positive direction. Ring gear 104 directly rotates the output tube 120 which extends back to the second set of clutches 124, to eventually rotate the output shaft 95 in a positive direction. Because its carrier 100 is fixed to the wall 21, there is only one input and one output for the mode two planetary 70. Thus, when the mode one planetary 68 is disengaged, the mode two planetary 70 can send the transmission 10 from a reverse mode to a forward mode by reducing the speed and then reversing the rotation of the carrier 72. The mode two planetary 70 also allows the transmission 10, while in its forward regime, to reach its upper operating speeds by transmitting power from input shaft 18 to output shaft 95 without any power being siphoned back to shaft 18. When the recirculating power loop is interrupted in this way, the transmission 10 is in its direct mode.

Thus, there are two power paths through the front end of the transmission 10. One path is from the main shaft 18 to the co-axial planetary carrier 36, and the other path is from the main shaft 18, through the toroidal drive 12 (i.e., inboard disk element 24) and to the input sun gear 34 of the co-axial planetary 16. Because the output sun gear 58 is smaller than the input sun gear 34, rotation of the carrier 36 by shaft 18 drives the output sun gear 58 in a negative direction. Because the toroidal drive 12 drives the input sun gear 34 in a negative direction, the input gear 34 also drives the output sun gear 58 in a negative direction. Accordingly, both of the power paths

through the front end of the transmission 10 drive the output sun gear 58 in the negative direction.

For the direct or second mode of the transmission 10, where the mode two planetary 70 is engaged and the transmission is in the forward regime, the two power paths share the total power flow, with each branch handling less than 100% of the power supplied by shaft 18. In the regenerated or first mode of the transmission 10, the shaft 18 is connected to the mixing planetary 68 and a portion of the power from the planetary 68 is recirculated through the toroidal drive 12. This recirculated power can exceed 100% of the power supplied by shaft 18. In addition, while shaft 18 has herein been described as supplying power into CVT 10 and shaft 95 has been described as transmitting power out of CVT 10, the flow of power in and out of CVT 10 can be reversed, with shaft 95 being the input and shaft 18 being the output.

A main purpose of a co-axial drive according to the present invention is to enable the input shaft and the output shaft of a transmission, incorporating the principles of the present co-axial drive, to be on the same axis without the need for parallel shafting. Without parallel shafting, a transmission according to the principles of the present invention is easier to package because it is long and narrow rather than wide. The use of a co-axial drive according to the present invention also eliminates the difficultly associated with manufacturing a housing for a parallel shaft transmission.

An important feature of the co-axial drive 16 used in the CVT 10 is that the torque reaction and axial reaction between the outboard traction disk pair 22 and 23 takes place through the carrier 36 of the co-axial planetary drive 16, while a separate power path is passed through the geared elements of the co-axial planetary 16.

Accordingly, instead of using the illustrated epicyclic planetary (see Figs. 1 and 3) for the co-axial drive 16, where the output is taken off of the second sun gear 58 from the compounded planet gears 38 and 40, a conventional planetary gear system, with single, double or compounded planet or pinion gears, could have been used for the co-axial drive 16, with the output being taken off of its ring gear. It is believed that

single, double or compounded planet or pinion gears may be used with any of the planetary gear arrangements discussed herein. In an example of such a modification of the co-axial drive 16, a first and second ring gear are mounted one around each of the compounded planet gears 38 and 40, respectively. The toroidal drive 12 is modified so that the center disk element 24 drives the first ring gear, thereby driving the planet gears 38 and 40. The output could then be taken off of the second ring gear. The outboard traction disk 22 of this exemplary drive system is driven directly by the main shaft 18, and the other outboard traction disk 23 is indirectly driven by the shaft 18 through the carrier 36. As an alternative, instead of taking the output off of a second ring gear, the output could be taken off of an output sun gear, for example, like the sun gear 58. A conventional planetary gear system has planet gears revolving around a sun gear and a ring gear around the outside engaging the planet gears. If the output is taken off of a conventional ring gear, different speed characteristics are obtained.

Instead of using a single planetary gear assembly for co-axial drive 16, multiple planetaries could also be used. For example, a first and second planetary gear assembly (not shown) can be used, with each having a sun gear, a planet gear, a planet carrier and a sun gear. In such an alternative assembly for co-axial drive 16, the first sun gear is geared to the inboard disk element 24, and the first carrier is splined to the second outboard disk 23 and the main shaft 18, as described above. In addition, the first carrier and the second ring gear are adapted to rotate with one another, and the first ring gear and the second sun gear are adapted to rotate with one another. The second carrier is then interconnected to the output. In a modification to this alternative co-axial drive, the first ring gear and the second carrier are adapted to rotate with one another, and the second sun gear is interconnected to the output. In another modification of this alternative drive, the first carrier and the second sun gear are adapted to rotate with one another, the first ring gear and the second carrier are adapted to rotate with one another, and the second ring gear is interconnected to the output. In an additional modification to this alternative co-axial drive, the first carrier and the

second sun gear are adapted to rotate with one another, the first and second ring gears are adapted to rotate with one another, and the second carrier is interconnected to the output. In a further modification to this alternative co-axial drive, the first and second carriers are adapted to rotate with one another, the first and second ring gears are adapted to rotate with one another, and the second sun gear is interconnected to the output.

Instead of using a planetary gear assembly, a fixed ratio planetary traction drive could be used for the co-axial drive of the present invention. In addition, if a dual cavity toroidal type drive with two separate inboard traction disks is used, the co-axial drive can also be placed between the separate inboard traction disks and still be driven off of its outboard disks. One embodiment of such an inboard disposed co-axial drive includes a sun gear splined for rotation with the input shaft. The sun gear is enmeshed with one planet gear of a dual pinion pair of meshed planet gears. The other planet gear is enmeshed with a ring gear. The ring gear is adapted for direct rotation with the two separate inboard disks. The two planet gears are supported between two circular flanges of a rotatable planetary carrier. Each of the flanges are splined for rotation with one of two torque tubes, each tube being disposed on either side of the sun gear and concentrically between one of the separate inboard disks and the input shaft. Each tube is also splined for rotation with one of the outboard disks. In a modification of this embodiment, the ring gear can be eliminated by joining the outer radial edges of the separate inboard disks together with a reaction or compression tube, and using three single pinion compound planet gears, one in the center and two on either side, instead of the pair of dual pinion planet gears. The circular flanges of the carrier are positioned one on either side of the center planet gear and inside of the two outside planet gears. A collar extending inboard from each of the two separate inboard disks is splined for rotation with one of the outside planet gears.

Thus, the co-axial drive used in the present invention can comprise many different planetary arrangements and can be disposed at various positions relative to the toroidal drive

without departing from the principles of the present invention. Regardless of its structure or location, the present co-axial drive should include a rotating planetary carrier that bisects the axial reaction path between the disks of a single cavity toroidal drive, and that bisects the axial and torque reaction path between one disk pair in the case of a dual cavity toroidal drive. In the dual cavity case, power from one or both of the other disks can be passed through the planetary elements (e.g., the sun gear/planet gear pairs or planet gear/ring gear pairs of a planetary type gear assembly) of the co-axial drive.

In addition, various fixed carrier ratios can be used in the epicyclic planetary for the illustrated co-axial drive 16. A fixed carrier ratio is the ratio of the output torque to the input torque (i.e., the input rotation divided by the output rotation), when the planetary carrier is not allowed to rotate. Usually, a sun gear is rotated to transmit the input torque and a ring gear is rotated to transmit the output torque. The output torque can be transmitted by either a ring gear or another sun gear. If the fixed carrier ratio of the planetary 16 is above one, then there will be a regeneration of power scheme, where some of the power is recirculated back through the toroidal drive 12 and back into the main shaft 18 of the transmission 10. If the fixed carrier ratio is less than one, then there will be a split power arrangement where the power into the front of the transmission 10 is split. Some of the power being split is carried down the main shaft 18 of the transmission 10 into the carrier 36. The rest of the power is routed into the toroidal drive 12 and from there into one of the driving members of the planetary 16, where the power combines with the power from the main shaft 18. Therefore, with this power scheme, the output from the planetary 16 is the sum of the power transmitted by the toroidal drive 12 and the power transmitted down the main shaft 18 to the carrier 36.

In a split power arrangement, the transmission 10 will exhibit a smaller overall ratio range for the whole transmission 10 than the ratio range within the toroidal drive 12. In a regenerated transmission, the transmission 10 exhibits an overall ratio range that can be more than or less than the ratio present in a continuously variable unit. In particular, when

the transmission 10 goes into the split power regime, the power will split as long as the fixed carrier ratio is less than one. When the fixed carrier ratio becomes less than zero (i.e., a negative number), then the overall ratio range is severely limited. With the carrier being fixed, if the rotation of the output is the same as the rotation of the input, then the fixed carrier ratio is a positive number. The fixed carrier ratio is negative, if the rotation of the output is opposite to the rotation of the input. In other words, the sign of the fixed carrier ratio indicates whether or not the output rotates in the same direction as the input, when the carrier 36 is held fixed.

It is believed desirable for the fixed carrier ratio to have a magnitude, either positive or negative, of up to about 8. It is believed more desirable for the fixed carrier ratio to have a magnitude, either positive or negative, of up to about 4. Desirable results have been obtained using fixed carrier ratios having a magnitude in the range of from about 0.75 to about 1.75.

From the above disclosure of the general principles of the present invention and the preceding detailed description, those skilled in this art will readily comprehend the various modifications to which the present invention is susceptible. Therefore, the scope of the invention should be limited only by the following claims and equivalents thereof.

What is claimed is:

CLAIMS

1. A thrust bearing assembly (11) comprising:

a thrust bearing (27) having an axis of rotation and a plurality of needle rollers (37) mounted circumferentially within an annular housing (39); and

at least one spring washer (15) disposed on a side of said thrust bearing (27) and having a curved cross-section operatively adapted so as to direct a load applied along said axis of rotation more toward the middle of each of said needle rollers (37).

2. The assembly (11) as set forth in claim 1, wherein said curved cross-section has a convex side (47), and said spring washer (15) is disposed so that said convex side (47) faces said thrust bearing (27).

3. The assembly (11) as set forth in claim 2, wherein said spring washer (15) has a circumference and substantially the same cross-sectional curvature around all of said circumference.

4. The assembly (11) as set forth in claim 2, wherein said convex side (47) has a substantially coplaner inner and outer diameter edge (51,53) and an apex therebetween which defines a contact circle (57).

5. The assembly (11) as set forth in claim 4, wherein each of said needle rollers (37) has a length, and said spring washer (15) is disposed relative to said thrust bearing (27) so that said contact circle (57) bisects each needle roller (37) about halfway along said length.

6. The assembly (11) as set forth in claim 4, wherein said assembly (11) further comprises a thrust washer (29) disposed on a side of said thrust bearing (27), and said contact circle (57) directly contacts said needle rollers (37) or said thrust washer (29).

7. The assembly (11) as set forth in claim 2, wherein said spring washer (15) is disposed relative to said thrust bearing (27) so that said convex side (47) directly contacts said needle rollers (37).

5 8. The assembly (11) as set forth in claim 1, wherein said curved cross-section flattens on both sides of the middle of each of said needle rollers (37), under a load applied along said axis of rotation.

9. A combination comprising:

10 two opposing surfaces, at least one of said surfaces being rotatable about an axis relative to the other of said surfaces; and

a thrust bearing assembly (11) mounted between said surfaces, said assembly (11) comprising:

15 a thrust bearing (27) having a plurality of needle rollers (37) mounted circumferentially within an annular housing (39), and

20 at least one spring washer (15) having a curved cross-section with a convex side (47), said convex side (47) having an inner diameter, an outer diameter and an apex therebetween which defines a contact circle (57), and said spring washer (15) being disposed on a side of said thrust bearing (27) so that said convex side (47) faces said thrust bearing (27).

25 10. The combination as set forth in claim 9, wherein said spring washer (15) is compressed so as to preload each of said needle rollers (37), while said thrust bearing assembly (11) is mounted between said opposing surfaces.

11. An apparatus comprising:

a thrust bearing assembly (11) comprising:

5 a thrust bearing (27) having a plurality of needle rollers (37) mounted circumferentially within an annular housing (39), and

at least one spring washer (15) having a curved cross-section operatively adapted so as to direct a normal load more toward the middle of each of said needle rollers (37); and

10 a mechanism having two elements separated by a gap, at least one of said elements being rotatable about an axis relative to the other of said elements, said thrust bearing assembly (11) being mounted in said gap so as to be sandwiched between said two elements and disposed around said axis.

15 12. The apparatus as set forth in claim 11, wherein said two elements are rotatable relative to one another about said axis and in opposite directions.

20 13. The apparatus as set forth in claim 11, wherein one of said elements has an annular shoulder and said thrust bearing assembly (11) is mounted thereon so as to be sandwiched between said two elements and disposed around said axis.

25 14. The apparatus as set forth in claim 11, wherein the curved cross-section of said spring washer (15) has a convex side (47) and a concave side (49), said convex side (47) has an inner diameter, an outer diameter and an apex therebetween which defines a contact circle (57), and said spring washer (15) is disposed on a side of said thrust bearing (27) so that said convex side (47) faces said thrust bearing (27) and said concave side (49) faces one of said two elements.

30 15. The apparatus as set forth in claim 14, wherein said concave side (49) directly contacts said one element.

16. The apparatus as set forth in claim 11, wherein said spring washer (15) is compressed so as to preload said thrust bearing (27) between said two elements.

17. The apparatus as set forth in claim 11, wherein said mechanism is a transmission.

18. The apparatus as set forth in claim 11, wherein said mechanism is a continuously variable transmission (10).

5 19. The apparatus as set forth in claim 11, wherein said mechanism is a portion of a transmission.

20. The apparatus as set forth in claim 11, wherein said mechanism is at least one of a toroidal drive (12), a co-axial drive (16) and an output gear section (14) of a transmission.

21. A transmission (10) having a power input and output which are co-axial along the same axis of rotation, said transmission (10) comprising:

5 a toroidal drive (12) having two traction disks (22,23) with at least one reaction path therebetween; and

a co-axial drive (16) having a planetary carrier (36) rotating around the axis of rotation and bisecting said at least one reaction path between said disks (22,23).

10 22. The transmission (10) of claim 21, wherein said traction disks (22,23) react axially along one reaction path therebetween and said carrier (36) bisects said one reaction path.

23. The transmission (10) claim 21, wherein said traction disks (22,23) react torsionally along one reaction path, and said carrier (36) bisects said one reaction path.

15 24. The transmission (10) claim 21, wherein said traction disks (22,23) react axially and torsionally along one reaction path, and said carrier (36) bisects said one reaction path.

20 25. The transmission (10) claim 21, wherein said toroidal drive (12) is a dual cavity toroidal drive, said disks (22,23) are outboard traction disks which react axially and torsionally along said at least one reaction path, and said carrier (36) bisects said at least one reaction path.

25 26. The transmission (10) claim 21, wherein said co-axial drive (16) has a plurality of elements carried by said carrier (36), and said elements are operatively adapted to provide a power path between the input and output of said transmission (10).

27. A transmission (10) having a co-axial power input and output, said transmission (10) comprising:

two shafts, one of said shafts being an input shaft (18) for supplying power to said transmission (10) and the other of said shafts being an output shaft (95) for transmitting power out from said transmission (10), each of said shafts (18,95) having substantially the same axis of rotation;

a toroidal drive (12) having two traction disks (22,23) with a reaction path therebetween, one of said disks (22,23) being mounted for rotation with one shaft of said shafts (18,95); and

a co-axial drive (16) comprising a planetary assembly with a rotating planetary carrier (36) bisecting the reaction path between said disks (22,23) and being interconnected between said one shaft and said toroidal drive (12), said toroidal drive (12) and said planetary assembly being operatively adapted for allowing power from said input shaft (18) to travel back and forth through said transmission (10), between said shafts (18,95) and along said substantially the same axis of rotation without the need for parallel shafting.

28. The transmission (10) of claim 27, wherein said toroidal drive (12) and said planetary assembly are operatively adapted for allowing power from said input shaft (18) to be transmitted through said toroidal drive (12) to said planetary assembly along the axis of rotation of said input shaft (18), and for allowing power from said input shaft (18) to be transmitted through said planetary assembly, then through said toroidal drive (12) and back to said input shaft (18) along the axis of rotation of said input shaft (18).

29. A transmission (10) comprising:

a first drive having an input shaft (18) for supplying power to said transmission (10), said input shaft (18) having an axis of rotation;

an output; and

a co-axial drive (16) interconnecting said first drive and said output,

wherein said first drive, said output and said co-axial drive (16) are operatively adapted for allowing power from said input shaft (18) to be transmitted through said first drive, through said co-axial drive (16) and to said output along
5 substantially the same axis of rotation as that of said input shaft (18), and for allowing power from said output to be transmitted through said co-axial drive (16), through said first drive and back to said input shaft (18) along said substantially the same axis of rotation, said transmission (10) being thereby
10 capable of exhibiting a recirculatory power loop from and back to said input shaft (18) without the need for parallel shafting.

30. The transmission (10) of claim 29, wherein said co-axial drive (16) is a planetary drive with a carrier (36), and said first drive is a toroidal drive (12) with two coupled traction
15 disks (22,23) which react torsionally to one another through said carrier (36).

31. The transmission (10) of claim 30, wherein the two coupled traction disks (22,23) of said toroidal drive (12) react torsionally and axially to one another through said carrier
20 (36).

32. The transmission (10) of claim 30, wherein one of said traction disks (22,23) is mounted to rotate with said input shaft (18), and said carrier (36) is operatively adapted to rotate with said input shaft (18) and the other of said traction
25 disks (22,23).

33. The transmission (10) of claim 30, wherein one of said traction disks (22,23) is operatively adapted to rotate with said input shaft (18), said co-axial drive (16) is a planetary gear assembly, and said carrier (36) includes a hub (54) mounted
30 to rotate with said input shaft (18) and a support flange (42) mounted to rotate with the other of said traction disks (22,23).

34. The transmission (10) of claim 30, wherein two stops (26,56) are mounted on said input shaft (18), one of said traction disks (22,23) is mounted to rotate with said input shaft (18), said carrier (36) includes a hub (54) mounted to rotate with said input shaft (18), and said one traction disk (22) and said hub (54) are each seated against one of said stops (26,56) such that said traction disks (22,23) and said planetary gear assembly (16) are substantially held axially in position relative to one another.

35. The transmission (10) of claim 29, wherein said first drive is a dual cavity toroidal drive (12) and includes two outboard traction disks (22,23) and at least one inboard traction disk (24) disposed between said outboard traction disks (22,23), said co-axial drive (16) is a planetary gear assembly, and said traction disks (22-24) and said planetary gear assembly (16) are axially held in position so that relative movement therebetween is substantially only rotational in nature.

36. The transmission (10) of claim 29, wherein said co-axial drive (16) is a planetary gear assembly with a carrier (36), and said first drive is a dual cavity toroidal drive (12) with two outboard traction disks (22,23) which react torsionally to one another through said carrier (36) and one dual-faced inboard traction disk (24) disposed between said outboard traction disks (22,23), said carrier (36) and one of said outboard traction disks (22,23) are each mounted to rotate around said axis of rotation with said input shaft (18), the other of said outboard traction disks (22,23) is operatively adapted to rotate around said axis of rotation with said input shaft (18) through said carrier (36), and said inboard traction disk (24) is operatively adapted to rotate around said axis of rotation in an opposite direction to that of said input shaft (18).

37. The transmission (10) of claim 36, wherein said output includes a gear interconnected with an output shaft, said planetary gear assembly (16) includes a compound planet gear (38,40) mounted on said carrier (36) and connecting one sun gear (34) with another sun gear (58), said inboard traction disk (24) is mounted for freely rotating around said input shaft (18) and is connected for rotation with said one sun gear (34) through a torque tube (32) disposed around said input shaft (18), and said other sun gear (58) is connected for rotation with said gear in said output.

38. The transmission (10) of claim 29, wherein said output is an output gear section (14) which includes a mode one planetary (68) which is a mixing planetary gear assembly with a first planet gear (74) and a mode two planetary (70) which is a speed reducer and reverser planetary gear assembly with a second planet gear (102), said mode one planetary (68) is operatively adapted so that said first planet gear (74) is rotatable by both said input shaft (18) and said co-axial drive (16), and said mode two planetary (70) is operatively adapted so that said second planet gear (102) is rotatable by said co-axial drive (16).

39. The transmission (10) of claim 38, wherein said planetary gear assembly (16) includes a compound planet gear (38,40) mounted on said carrier (36) and connecting a first sun gear (34) with a second sun gear (58), said mode one planetary (68) has a third sun gear (64) and said mode two planetary (70) has a fourth sun gear (66), said third and fourth sun gears (64,66) are each connected for rotation with said second sun gear (58) through a torque tube (62) and engaged with said first planet gear (74) and said second planet gear (102), respectively.

40. A trunnion/roller assembly (13) mountable between a pair of traction disks in a toroidal drive, said trunnion/roller assembly (13) comprising:

a traction roller (25);

5 a roller loading assembly (147) for applying an axial loading force to said traction roller (25) to provide a contact force between said traction roller (25) and a traction disk, said roller loading assembly (147) comprising a load piston (153) having a face (159) and an alignment shaft (157)
10 extending out from said face (159) and into a hole formed in said traction roller (25), and a plurality of levers (163) for amplifying the loading force from said load piston (153), said levers (163) being mounted around said alignment shaft (157) with each lever (163) having an end (165) in position to at
15 least be contacted by said face (159); and

a trunnion (125) mounting said traction roller (25) and said roller loading assembly (147).

41. The trunnion/roller assembly (13) as set forth in claim 40, wherein said alignment shaft (157) extends out from said face (159) and substantially through a hole formed through said
20 traction roller (25).

42. The trunnion/roller assembly (13) as set forth in claim 40, wherein said trunnion/roller assembly (13) further comprises a thrust plate (167) mounted between said plurality of levers (163) and said traction roller (25), and said thrust plate (167)
25 includes an alignment collar (169) extending therefrom and disposed around said alignment shaft (157) and into said hole of said traction roller (25).

43. The trunnion/roller assembly (13) as set forth in claim 42, wherein said alignment collar (169) forms a slip fit around said
30 alignment shaft (157).

44. The trunnion/roller assembly (13) as set forth in claim 40, wherein said trunnion/roller assembly (13) further comprises a thrust plate (167) mounted between said plurality of levers (163) and said traction roller (25), said thrust plate (167) having an outer surface mounted within said trunnion (125) so as to form a slip fit.

45. The trunnion/roller assembly (13) as set forth in claim 40, wherein said roller loading assembly (147) includes at least one spring (155) mounted in said trunnion (125) so as to apply an axial preload force on said load piston (153) in a direction to extend said load piston (153) toward said roller (25).

46. The trunnion/roller assembly (13) as set forth in claim 45, wherein said at least one spring (155) is a series of wave springs mounted between said load piston (153) and said trunnion (125).

47. The trunnion/roller assembly (13) as set forth in claim 40, wherein said end (165) of each of said levers (163) is in contact with said face (159) and said alignment shaft (157), and each said end (165) is chamfered so as to angle away from said alignment shaft (157) and toward said face (159).

48. The trunnion/roller assembly (13) as set forth in claim 40, wherein said trunnion/roller assembly (13) further comprises a spring loaded check valve (201) hydraulically interconnected with said roller loading assembly (147) and used in controlling movement of said trunnion (125) and hydraulic pressure applied to said load piston (153).

49. The trunnion/roller assembly (13) as set forth in claim 48, wherein said trunnion (125) is an axially moveable trunnion, said trunnion/roller assembly (13) further comprises a ratio control assembly (179) hydraulically interconnected with said roller loading assembly (147) for controlling axial movement of said trunnion (125) and hydraulic loading applied by said load piston (153), said ratio control assembly (179) includes a

control piston (181) with a fluid chamber on either side thereof for axially moving said trunnion (125), and said control piston (181) includes at least one said spring loaded check valve (201) for hydraulically interconnecting said ratio control assembly (179) with said roller loading assembly (147) while isolating each fluid chamber from one another.

50. A trunnion/roller assembly (13) mountable between a pair of traction disks in a toroidal drive, said trunnion/roller assembly (13) comprising:

- 10 a traction roller (25);
a roller loading assembly (147) for applying an axial loading force to said traction roller (25) to provide a contact force between said traction roller (25) and a traction disk, said roller loading assembly (147) comprising a load piston (153) through which the axial loading force is applied, at least one spring (155) mounted so as to apply an axial preload force on said load piston (153) in a direction to extend said load piston (153) toward said traction roller (25), and a plurality of levers (163) mounted between said load piston (153) and said traction roller (25) for amplifying the axial loading force being applied; and
- 20 a trunnion (125) mounting said traction roller (25) and said roller loading assembly (147).

51. The trunnion/roller assembly (13) as set forth in claim 50, wherein said at least one spring (155) is a series of springs mounted between said load piston (153) and said trunnion (125).

52. The trunnion/roller assembly (13) as set forth in claim 50, wherein said load piston (153) has a face (159) and an alignment shaft (157) extending out from said face (159) and into a hole formed in said traction roller (25)

53. The trunnion/roller assembly (13) as set forth in claim 52, wherein said alignment shaft (157) extends out from said face (159) and substantially through a hole formed through said traction roller (25).

54. The trunnion/roller assembly (13) as set forth in claim 52, wherein said trunnion/roller assembly (13) further comprises a thrust plate (167) mounted between said plurality of levers (163) and said traction roller (25), and said thrust plate (167) includes an alignment collar (169) extending therefrom and disposed around said alignment shaft (157) and into said hole of said traction roller (25).

55. The trunnion/roller assembly (13) as set forth in claim 54, wherein said alignment collar (169) forms a slip fit around said alignment shaft (157).

56. The trunnion/roller assembly (13) as set forth in claim 50, wherein said trunnion/roller assembly (13) further comprises a thrust plate (167) mounted between said plurality of levers (163) and said traction roller (25), said thrust plate (167) having an outer surface mounted within said trunnion (125) so as to form a slip fit.

57. The trunnion/roller assembly (13) as set forth in claim 50, wherein said trunnion/roller assembly (13) further comprises a spring loaded check valve (201) hydraulically interconnected with said roller loading assembly (147) and used in controlling movement of said trunnion (125) and hydraulic pressure applied to said load piston (153).

58. The trunnion/roller assembly (13) as set forth in claim 57, wherein said trunnion (125) is an axially moveable trunnion, said trunnion/roller assembly (13) further comprises a ratio control assembly (179) hydraulically interconnected with said roller loading assembly (147) for controlling axial movement of said trunnion (125) and hydraulic loading applied by said load piston (153), said ratio control assembly (179) includes a control piston (181) with a fluid chamber on either side thereof for axially moving said trunnion (125), and said control piston (181) includes at least one said spring loaded check valve (201) for hydraulically interconnecting said ratio control assembly

(179) with said roller loading assembly (147) while isolating each fluid chamber from one another.

59. A trunnion/roller assembly (13) mountable between a pair of traction disks in a toroidal drive, said trunnion/roller assembly (13) comprising:

a traction roller (25);

a roller loading assembly (147) for applying an axial loading force to said traction roller (25) to provide a contact force between said traction roller (25) and a traction disk, said roller loading assembly (147) comprising a load piston (153) through which the axial loading force is applied and a plurality of levers (163) mounted between said load piston (153) and said traction roller (25) for amplifying the axial loading force being applied;

a thrust plate (167) mounted between said plurality of levers (163) and said traction roller (25), said thrust plate (167) having an outer surface mounted so as to form a slip fit within said trunnion (125); and

a trunnion (125) mounting said traction roller (25), said roller loading assembly (147), and said thrust plate (167).

60. The trunnion/roller assembly (13) as set forth in claim 59, wherein said thrust plate (167) includes an alignment stud (169) extending therefrom and into a hole formed in said traction roller (25).

61. The trunnion/roller assembly (13) as set forth in claim 60, wherein said alignment stud (169) is fixed to said traction roller (25) so as to not allow said alignment stud (169) to move a substantial amount from side-to-side within said hole formed in said traction roller (25).

62. A trunnion/roller assembly (13) mountable between a pair of traction disks in a toroidal drive, said trunnion/roller assembly (13) comprising:

a traction roller (25);

a roller loading assembly (147) for applying an axial loading force to said traction roller (25) to provide a contact force between said traction roller (25) and a traction disk, said roller loading assembly (147) comprising a load piston
5 (153) through which the axial loading force is applied and a plurality of levers (163) mounted between said load piston (153) and said traction roller (25) for amplifying the axial loading force being applied;

a moveable trunnion (125) mounting said traction roller
10 (25) and said roller loading assembly (147); and

a spring loaded check valve (201) hydraulically interconnected with said roller loading assembly (147) and used in controlling movement of said trunnion (125) and hydraulic pressure applied to said load piston (153).

15 63. The trunnion/roller assembly (13) as set forth in claim 62, wherein said trunnion (125) is an axially moveable trunnion, said trunnion/roller assembly (13) further comprises a ratio control assembly (179) hydraulically interconnected with said roller loading assembly (147) for controlling axial movement of
20 said trunnion (125) and hydraulic loading applied by said load piston (153), said ratio control assembly (179) includes a control piston (181) with a fluid chamber on either side thereof for axially moving said trunnion (125), and said control piston (181) includes at least one said spring loaded check valve (201)
25 for hydraulically interconnecting said ratio control assembly (179) with said roller loading assembly (147) while isolating each fluid chamber from one another.

64. The trunnion/roller assembly (13) as set forth in claim 63, wherein said trunnion (125) is end supported, and said ratio
30 control assembly (179) is operatively adapted so that said control piston (181) has the freedom to move from side-to-side in response to axial movement of said trunnion (125).

65. A transmission (10) comprising:

a toroidal drive (12) comprising:

a plurality of axially moveable trunnion assemblies (13), each trunnion assembly (13) having opposite ends and a longitudinal axis, and

a plurality of traction disks (23,24) defining at least one cavity in which said trunnion assemblies (13) are disposed; and

a trunnion linkage system (126) for linking together and supporting said trunnion assemblies (13) in said toroidal drive (12), said linkage system (126) being mounted in said transmission (10) so as to allow each trunnion assembly (13) to freely move along a substantially axial direction and rotate about the longitudinal axis thereof, and said linkage system (126) comprising:

a first set of links comprising at least one cross link (134,136) and two side links (130,131), and a second set of links comprising at least one other cross link (135,137) and two other side links (132, 133), each of said links having opposite ends, and

a plurality of trunnion bearings (127,128) and a plurality of link bearings (139,141), each side link mounting at least one trunnion bearing, each cross link mounting two spaced apart link bearings and being mounted in said transmission (10) so as to pivot about a point between said two spaced apart link bearings, each end of said trunnion assemblies (13) mounting one trunnion bearing so as to allow each trunnion assembly (13) to freely rotate about the longitudinal axis thereof, and each end of said side links mounting one of said link bearings so as to allow each of said trunnion assemblies (13) to freely move axially.

66. The transmission (10) set forth in claim 65, wherein said toroidal drive (12) is a dual-cavity toroidal drive, a longitudinal reaction occurs in each cavity of said toroidal drive (12), and said linkage system (126) connects the two

cavities of said toroidal drive (12) such that the longitudinal reaction of one cavity is balanced by that of the other cavity.

67. The transmission (10) set forth in claim 65, wherein said toroidal drive (12) has a longitudinal axis, and said trunnion
5 linkage system (126) is mounted in said toroidal drive (12) so that each cross link transversely crosses said toroidal drive (12) at about right angles to the longitudinal axis of said toroidal drive (12).

68. The transmission (10) as set forth in claim 65, wherein
10 said trunnion bearings (127,128) and said link bearings (139,141) are at least one of rolling element bearings and plane bearings.

69. The transmission (10) as set forth in claim 65, wherein
15 each end of said side links (130-133) mounts one of said link bearings (139,141) so as to allow each of said side links (130-133) to rotate about the longitudinal axis thereof and thereby allow each of said trunnion assemblies (13) to freely move axially.

70. The transmission (10) as set forth in claim 65, wherein
20 said linkage system (126) further comprises at least one spring (144) mounted within said transmission (10) so as to support the weight of said links (130-137) and said trunnion assemblies (13), said spring (144) has a low enough spring constant not to substantially determine the axial position of said trunnion
25 assemblies (13) relative to said traction disks (23,24).

71. The transmission (10) as set forth in claim 65, wherein
30 said linkage system (126) further comprises at least one pivot pin (143,146) and at least one spring (144), at least one cross link is mounted with one pivot pin in said toroidal drive (12) so as to pivot about or pivot with said one pivot pin as each of said trunnion assemblies (13) moves axially, said spring (144) is mounted in said toroidal drive (12) and is of

sufficient spring force and length to support the weight of said links (130-137) and said trunnion assemblies (13) and maintain a gap between said one pivot pin and at least one stop surface forming part of said transmission (10), said gap being small
5 enough to prevent said trunnion assemblies (13) from moving a substantial amount out of center with said at least one cavity.

72. The transmission (10) as set forth in claim 71, wherein said one pivot pin (143) is mounted to one of said cross links (134-137) and disposed in a notch formed inside of said toroidal
10 drive (12), and said notch has a bottom surface forming said stop surface.

73. The transmission (10) as set forth in claim 71, wherein said one pivot pin (146) is disposed in an opening (148) defined by a portion of said transmission (10), said opening (148) is
15 operatively adapted so as to prevent said one pivot pin (146) from moving transversely from side-to-side an appreciable amount and thereby prevent a roller (25), from one of said trunnion assemblies (13), from extending more than another roller (25), from an opposing one of said trunnion assemblies (13), in the
20 same said cavity.

74. The transmission (10) as set forth in claim 71, wherein said gap is large enough to allow said linkage system (126) and all of said trunnion assemblies (13) to move up and down as a whole, yet small enough to prevent said linkage system (126) and
25 said trunnion assemblies (13), as a whole, from moving a substantial amount out of center with said at least one cavity.

75. The transmission (10) as set forth in claim 71, wherein said spring (144) has a low enough spring constant not to substantially determine the axial position of said trunnion
30 assemblies (13) relative to said traction disks (23,24)

76. The transmission (10) as set forth in claim 71, wherein each said spring (144) is a compression spring having a spring

rate that is sufficiently low so that said compression spring exerts a spring force, over the deflection range of said compression spring, that does not substantially determine the axial position of said trunnion assemblies (13) relative to said traction disks (23,24).

77. The transmission (10) as set forth in claim 71, wherein each said spring (144) is a compression spring, and is mounted in said transmission (10) and is of sufficient spring force and length so as not to be over-compressed or bottomed out by said one pivot pin contacting said stop surface.

78. The transmission (10) as set forth in claim 71, wherein said at least one stop surface is at least two stop surfaces disposed one on either side of said one pivot pin and along a direction substantially parallel to the axial direction of movement of said trunnion assemblies (13), and said at least one spring (144) maintains said gap between each of said two stop surfaces and said one pivot pin.

79. The transmission (10) as set forth in claim 71, wherein said toroidal drive (12) is a dual-cavity toroidal drive, said at least one pivot pin is a plurality of pivot pins (143,146), said at least one cross link from said first set of links is two cross links (134,136), said at least one cross link from said second set of links is two other cross links (135,137), one cross link from each set of links is disposed in each cavity, at least one cross link in each cavity is mounted in said toroidal drive (12) with one of said pivot pins (143,146) so as to pivot about or pivot therewith as each of said trunnion assemblies (13) moves axially, said at least one spring (144) is a plurality of springs (144) with at least one spring (144) being disposed in each cavity, said at least one stop surface is at least two stop surfaces, and said springs (144) are mounted in said toroidal drive (12) and are of sufficient spring force and length to support the weight of said links (130-137) and said trunnion assemblies (13) and maintain said gap between

each of said pivot pins (143,146) and at least one of said stop surfaces.

80. The transmission (10) as set forth in claim 79, wherein each of said pivot pins (143,146) is disposed in one of a plurality of openings defined by portions of said transmission (10), said openings are operatively adapted so as to prevent said pivot pins (143,146) from moving transversely from side-to-side an appreciable amount and to thereby prevent a roller (25), from one of said trunnion assemblies (13), from extending more than another roller (25), from an opposing one of said trunnion assemblies (13), in the same said cavity.

81. The transmission (10) as set forth in claim 79, wherein said at least one stop surface is a plurality of stop surfaces, two of said stop surfaces are disposed one on either side of each of said pivot pins (143,146) and along a direction substantially parallel to the axial direction of movement of said trunnion assemblies (13), and said springs (144) maintain said gap between each of said two stop surfaces and one of said pivot pins (143,146).

82. The transmission (10) as set forth in claim 79, wherein a longitudinal reaction occurs in each cavity of said toroidal drive (12), and said linkage system (126) connects the two cavities of said toroidal drive (12) such that the longitudinal reaction of one cavity is balanced by that of the other cavity.

83. The transmission (10) as set forth in claim 65, wherein said transmission (10) has a longitudinal axis and includes a transmission housing (19), said toroidal drive (12) and said linkage system (126) are mounted in said housing (19), and said linkage system (126) includes at least one locator to maintain said toroidal drive (12) longitudinally in position within said housing (19) while allowing for some transverse movement of said linkage system (126) therein.

84. The transmission (10) as set forth in claim 83, wherein said locator is operatively adapted to constrain the movement of one or the other of at least one cross link (134-137) and at least one side link (130-133) along the longitudinal axis of said transmission (10) by contact with corresponding portions of said transmission (10)

85. The transmission (10) as set forth in claim 65, wherein each of said trunnion bearings (127,128) includes an inner bushing (119,121) with a rectangular hole formed therein, each of said trunnion assemblies (13) includes a trunnion (125) having opposite ends, each of said opposite ends has a rectangular cross section disposed in and adapted to snugly fit in said rectangular hole of its corresponding bushing (119,121) only along two opposing sides.

86. The transmission (10) as set forth in claim 65, wherein said trunnion assemblies (13) are hydraulically loaded and interconnected at the same one end by a train of phase gears (203,205,208,209) so as to prevent said trunnion assemblies (13) from wandering grossly out of rotational phase with each other when the hydraulic loading of said trunnion assemblies (13) is inactive.

87. The transmission (10) as set forth in claim 65, wherein said transmission (10) includes a plurality of ratio control assemblies (179) for controlling the axial movement of said trunnion assemblies (13), each control assembly (179) includes a control piston (181) mounted at one end of one trunnion assembly (13) for axially moving said one trunnion assembly (13), and each of said control assemblies (179) is operatively adapted so that each control piston (181) has the freedom to move from side-to-side in response to the pivoting of each cross link (134-137) during the axial movement of said trunnion assemblies (13).

88. A transmission (10) comprising:

a toroidal drive (12) comprising:

a plurality of axially moveable trunnion assemblies (13), each trunnion assembly (13) having opposite ends and a longitudinal axis, and

a plurality of traction disks (23,24) defining at least one cavity in which said trunnion assemblies (13) are disposed; and

a trunnion linkage system (126) for linking together and supporting said trunnion assemblies (13) in said toroidal drive (12), said linkage system (126) being mounted in said transmission (10) so as to allow each trunnion assembly (13) to freely move along a substantially axial direction and rotate about the longitudinal axis thereof, said linkage system (126) comprising:

at least one first link connecting the same one end of each trunnion assembly (13),

at least one second link connecting the other end of each trunnion assembly (13), and

at least one spring (144) being mounted in said toroidal drive (12) and being of sufficient spring force and length to support the weight of said first and second link and said trunnion assemblies (13) and maintain a gap between a portion of one link and at least one stop surface forming part of said transmission (10), said gap being small enough to prevent said trunnion assemblies (13) from moving a substantial amount out of center with said at least one cavity.

89. The transmission (10) as set forth in claim 88, wherein said gap is large enough to allow said linkage system (126) and all of said trunnion assemblies (13) to move up and down as a whole, yet small enough to prevent said linkage system (126) and said trunnion assemblies (13), as a whole, from moving a substantial amount out of center with said at least one cavity.

90. The transmission (10) as set forth in claim 88, wherein said spring (144) has a low enough spring constant not to substantially determine the axial position of said trunnion assemblies (13) relative to said traction disks (23,24)

5 91. The transmission (10) as set forth in claim 88, wherein
each said spring (144) is a compression spring having a spring
rate that is sufficiently low so that said compression spring
exerts a spring force, over the deflection range of said
compression spring, that does not substantially determine the
10 axial position of said trunnion assemblies (13) relative to said
traction disks (23,24).

92. The transmission (10) as set forth in claim 88, wherein
each said spring (144) is a compression spring, and is mounted
in said transmission (10) and is of sufficient spring force and
15 length so as not to be over-compressed or bottomed out by the
portion of said one link contacting said stop surface.

93. A trunnion linkage system (126) for linking together opposite ends of a plurality of axially moveable trunnion assemblies (13) in a toroidal drive, each trunnion assembly (13) having a longitudinal axis, said linkage system (126) comprising:

5 a first set of links comprising at least one cross link (134,136) and two side links (130,131), and a second set of links comprising at least one other cross link (135,137) and two other side links (132, 133), each of said links having opposite ends,; and

10 a plurality of trunnion bearings (127,128) and a plurality of link bearings (139,141), each side link (130-133) mounting at least one trunnion bearing (127,128), each cross link (134-137) mounting a link bearing (139,141) at spaced locations thereon, and said links (130-137) being mountable in the toroidal drive so as to allow each of the trunnion assemblies (13) to freely move axially and rotate about the longitudinal axis thereof, with each trunnion bearing (127,128) being mountable on one end of one of the trunnion assemblies (13) so as to allow each of the trunnion assemblies (13) to freely rotate about the longitudinal axis thereof, and with each link bearing (139,141) mounting one end of one of said side links (130-133) so as to allow each of the trunnion assemblies (13) to freely move axially.

25 94. The linkage system (126) as set for in claim 93, wherein each side link (130-133) has a longitudinal axis, each link bearing (139,141) and each trunnion bearing (127,128) is a needle bearing with needle rollers, each needle roller in each link bearing (139,141) has a longitudinal axis that is generally parallel with the longitudinal axis of the corresponding side link (130-133), and each needle roller in each trunnion bearing (127,128) has a longitudinal axis that is generally parallel with the longitudinal axis of the corresponding trunnion assembly (13).

30

FIG. 2

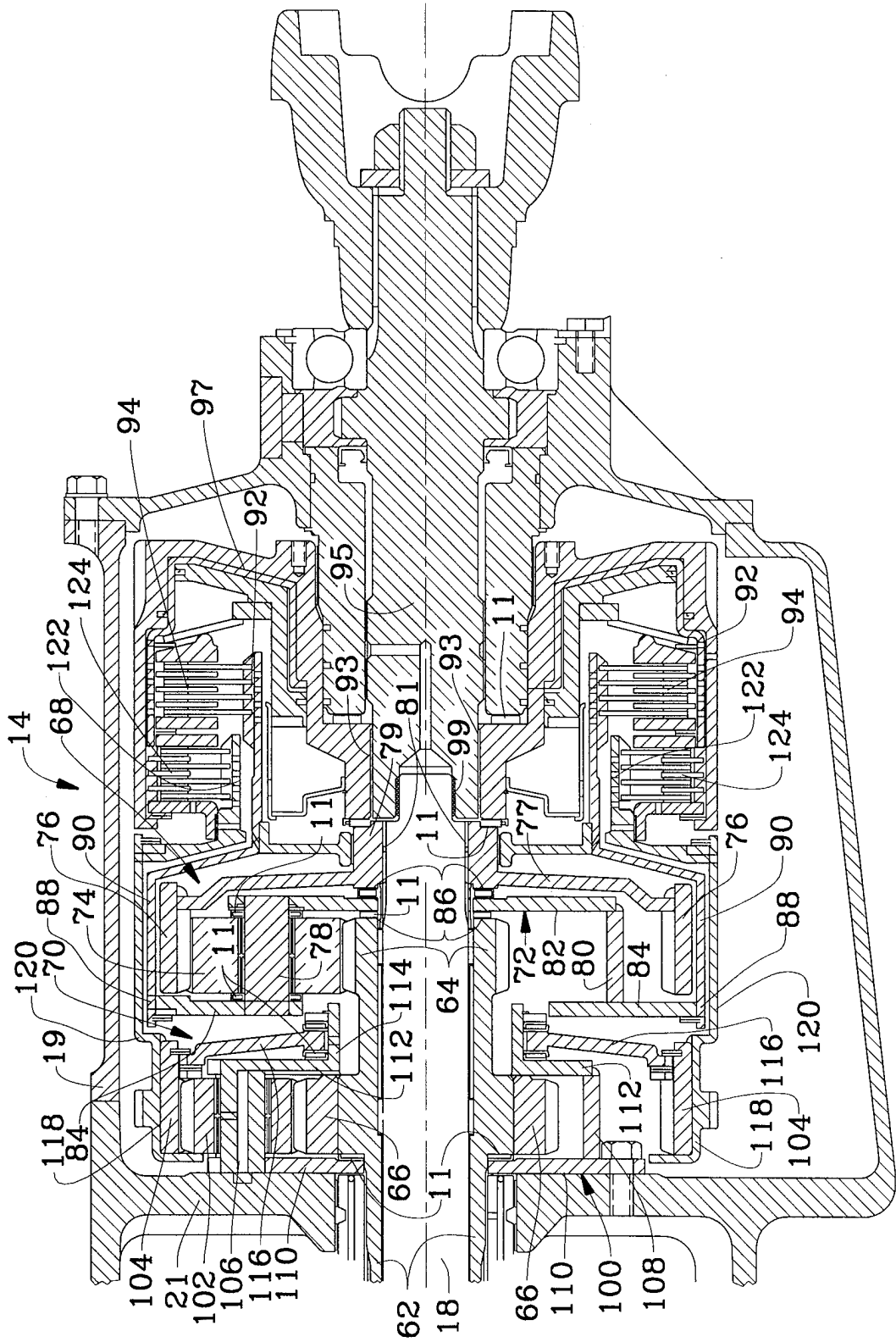
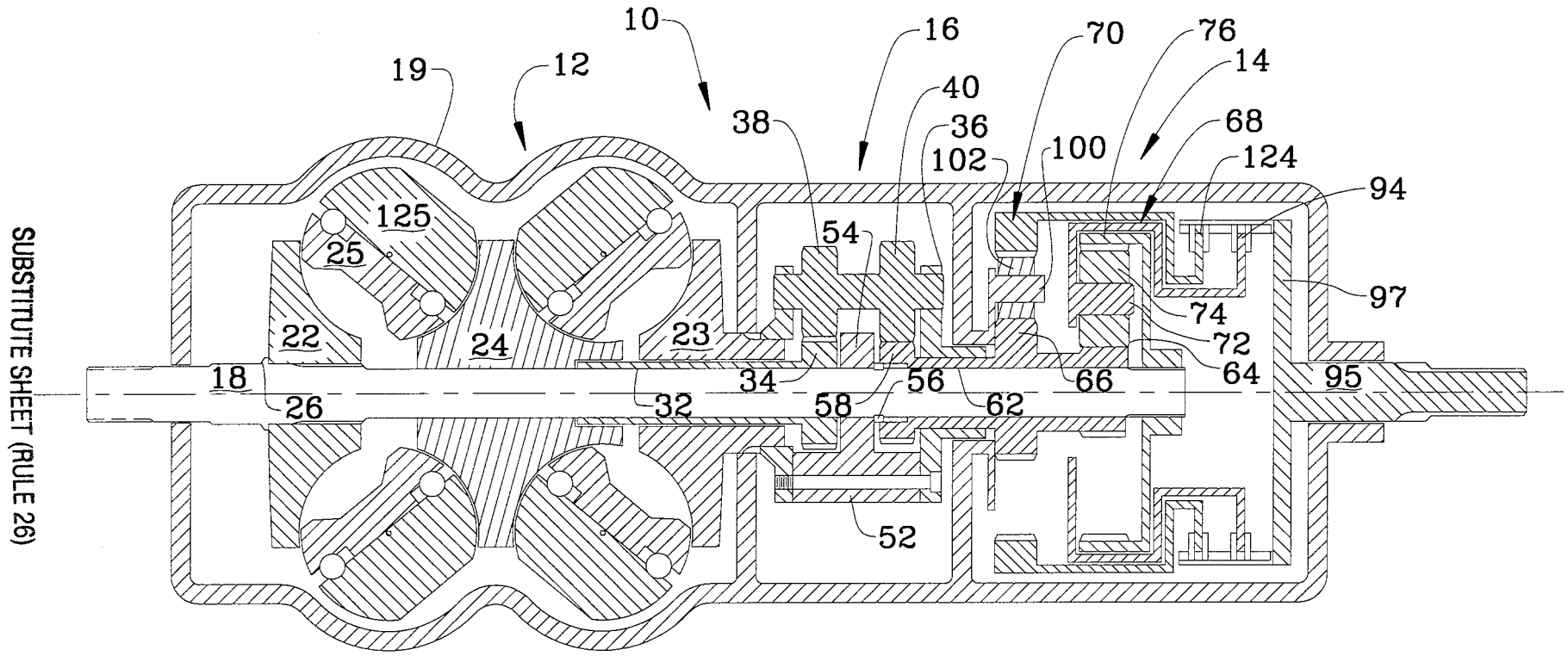
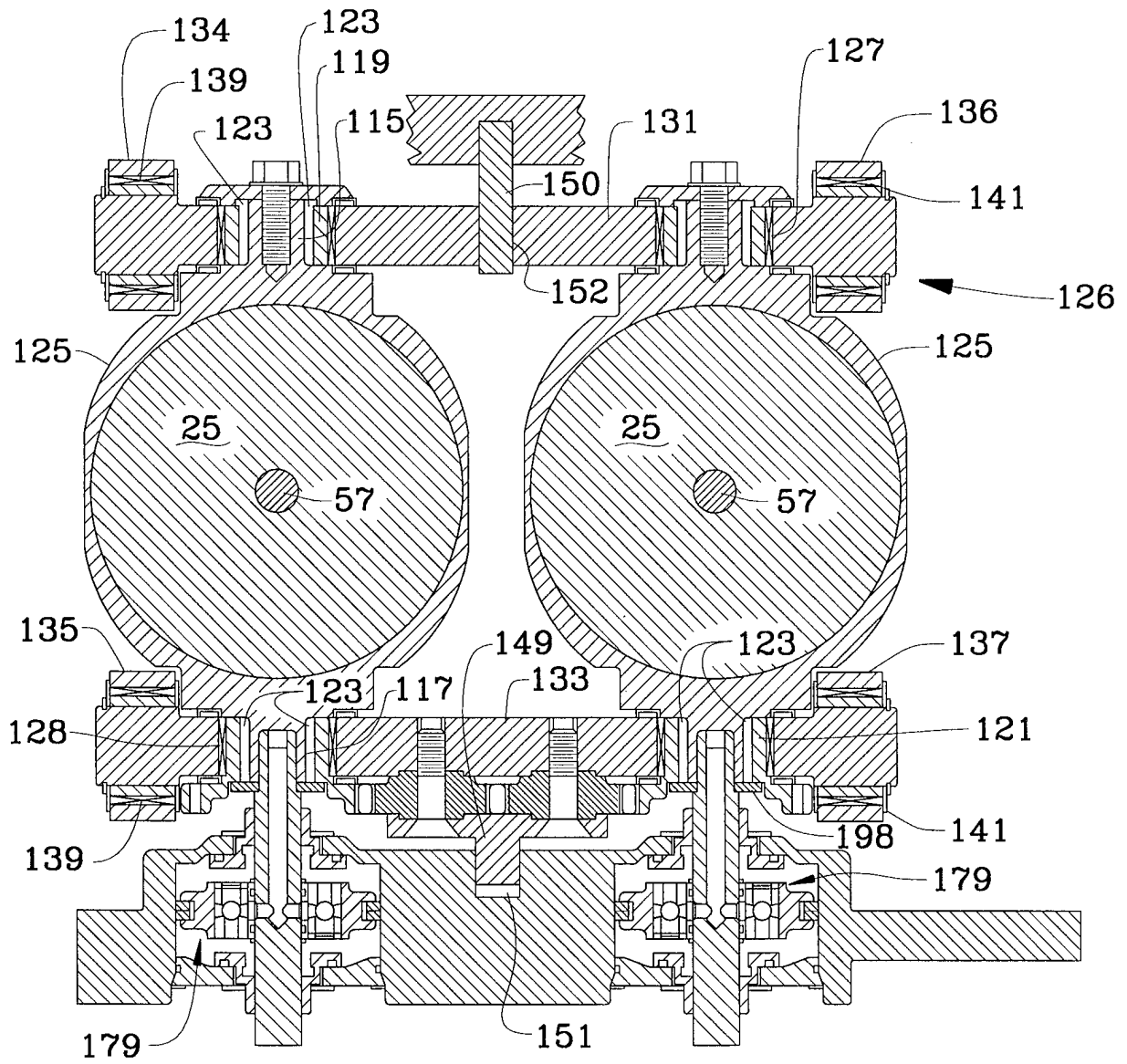

FIG. 3



SUBSTITUTE SHEET (RULE 26)

FIG. 5



6/11

FIG. 6

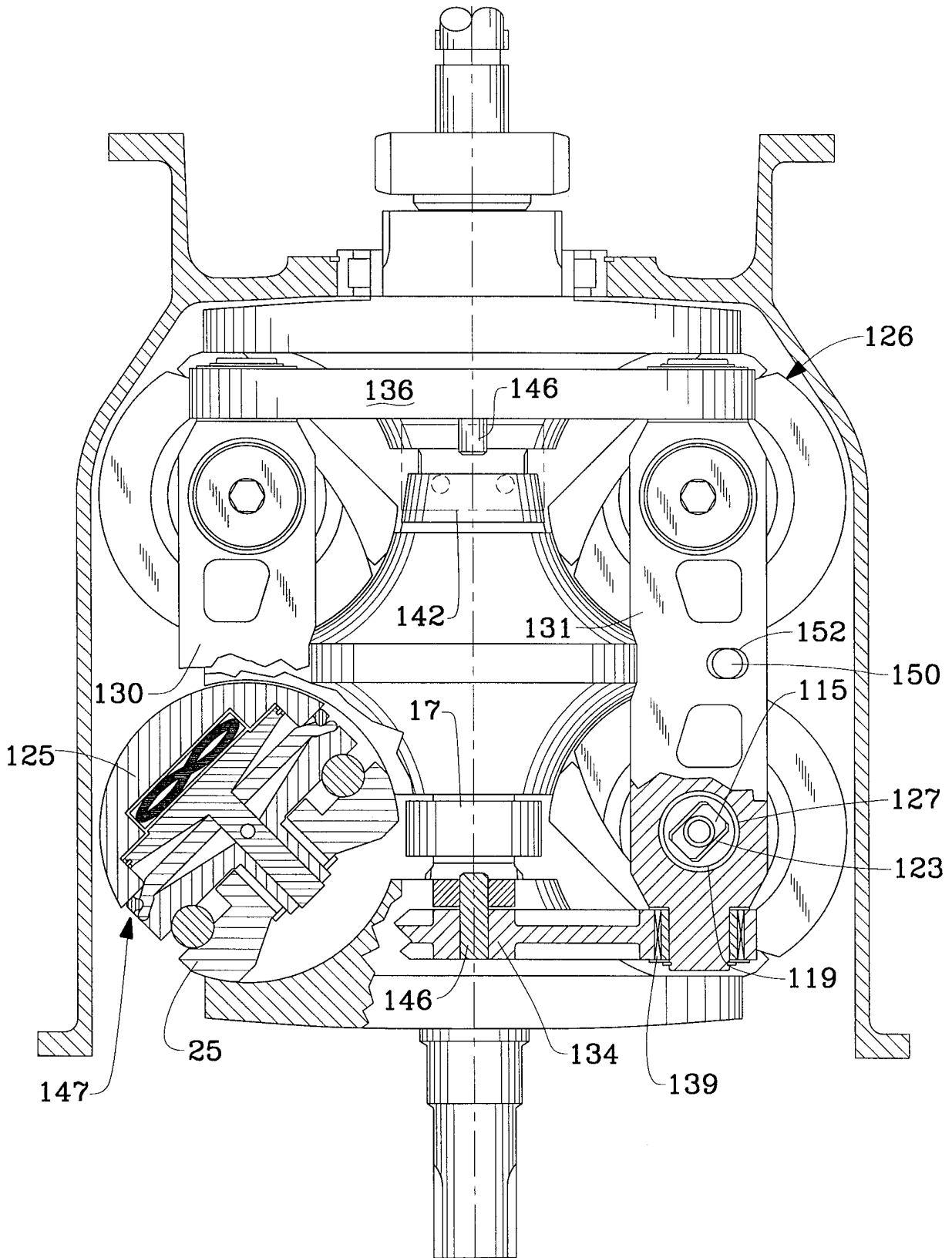

7/11
FIG. 7

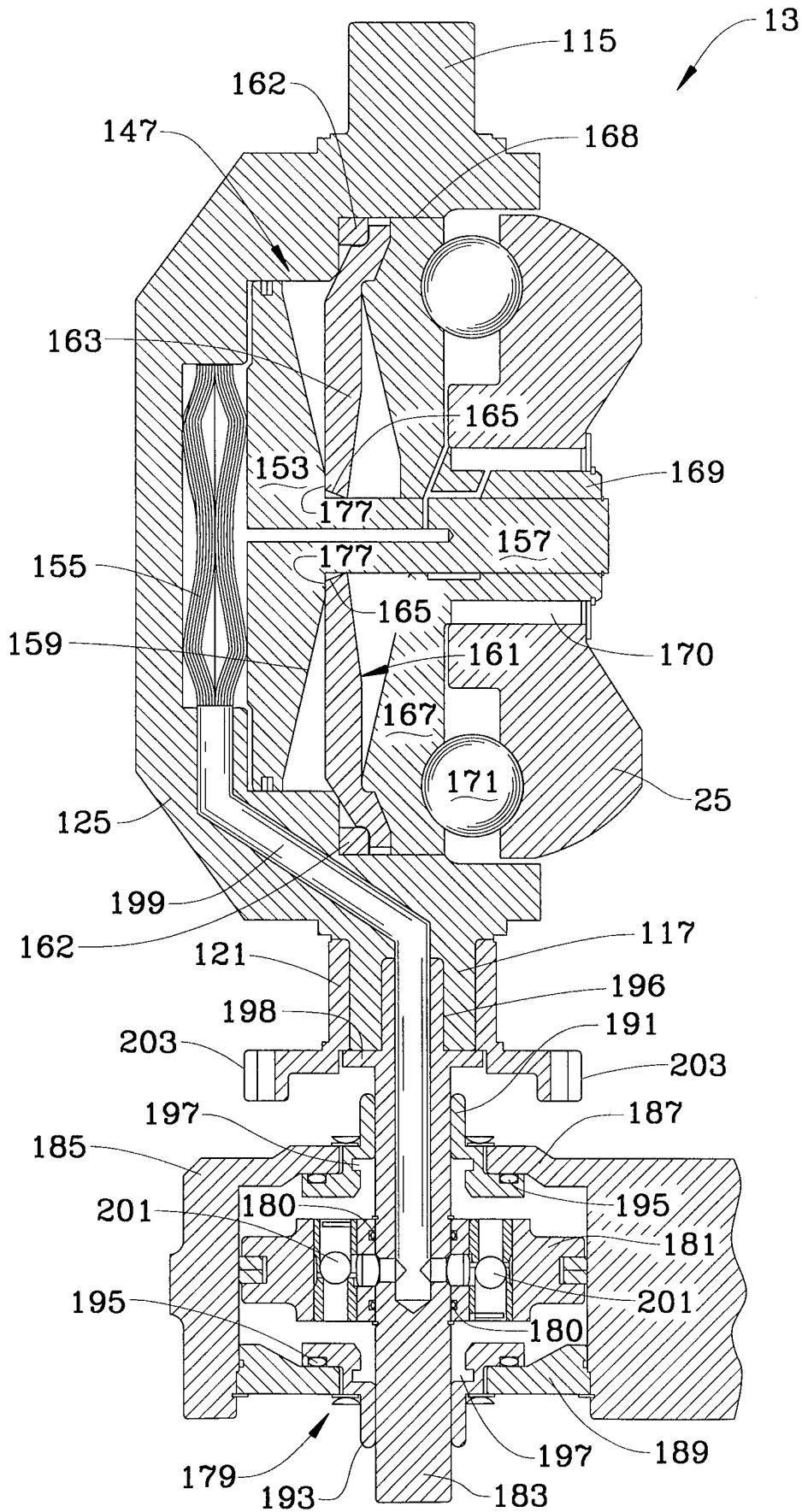

FIG. 8

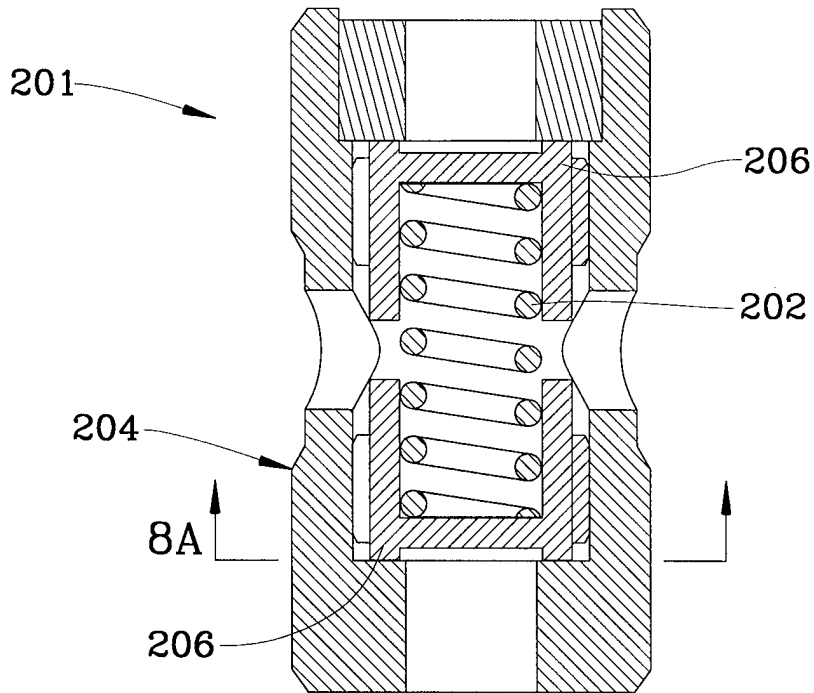

FIG. 8A

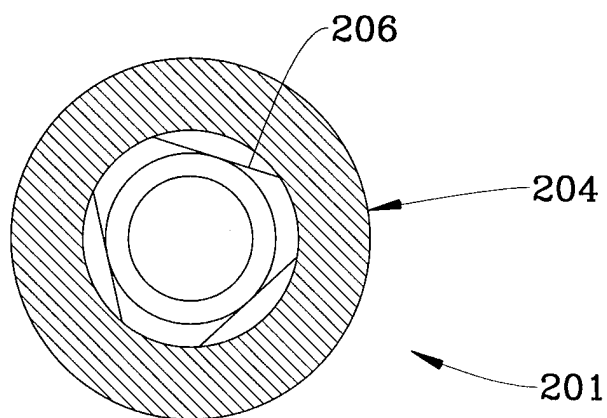
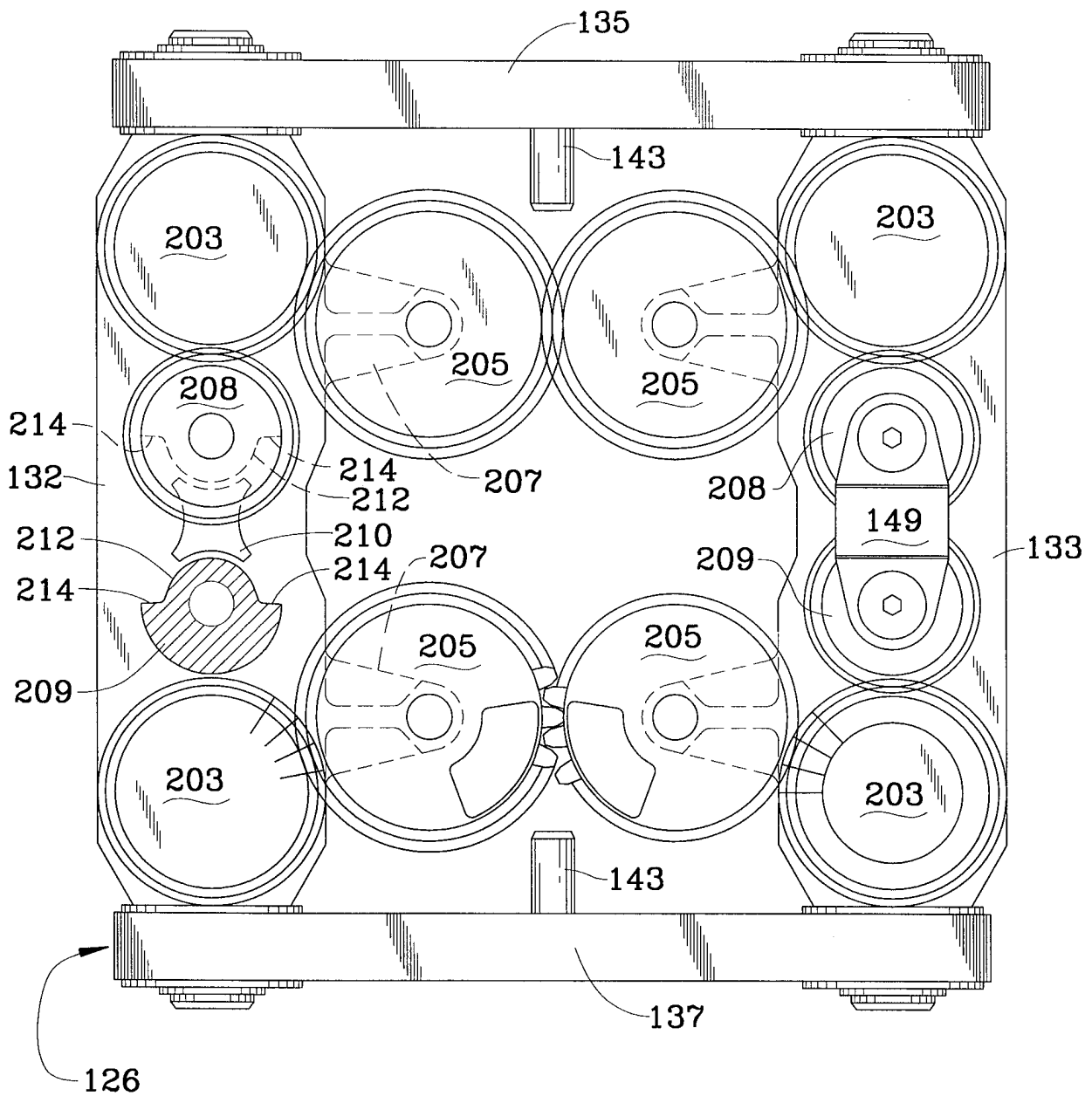

FIG. 9



10/11

FIG. 10

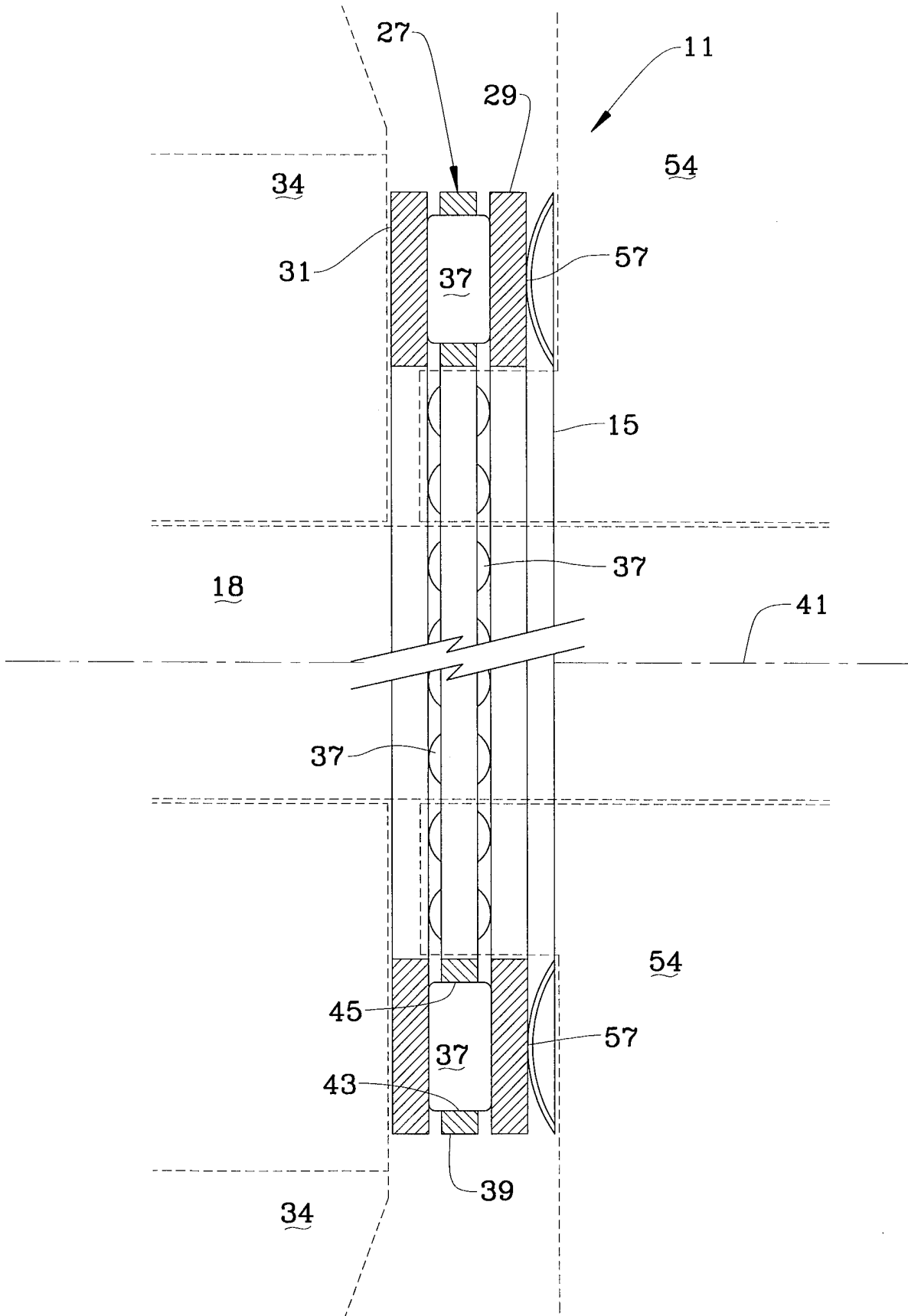

FIG. 11

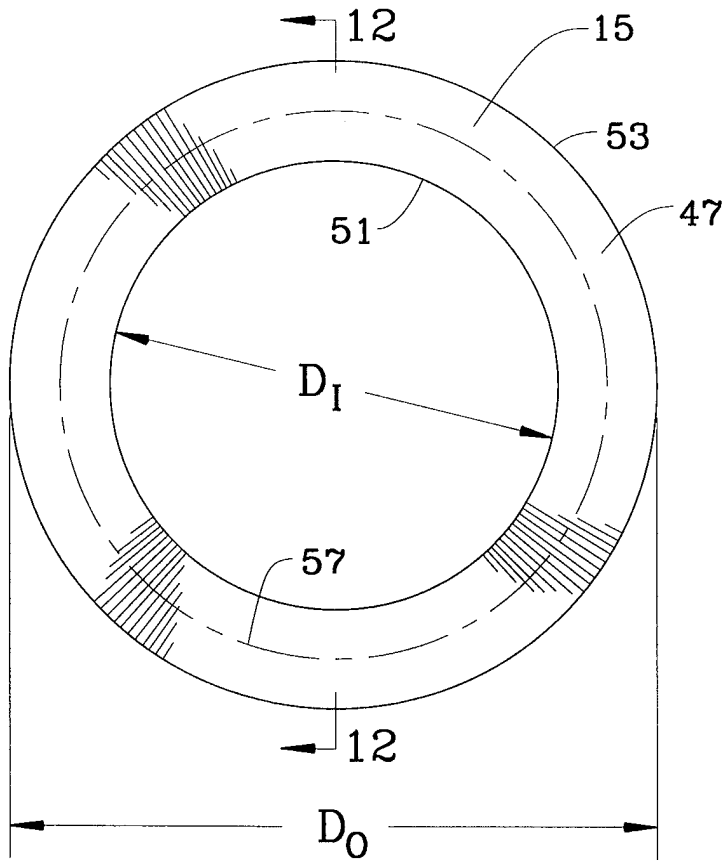

FIG. 12

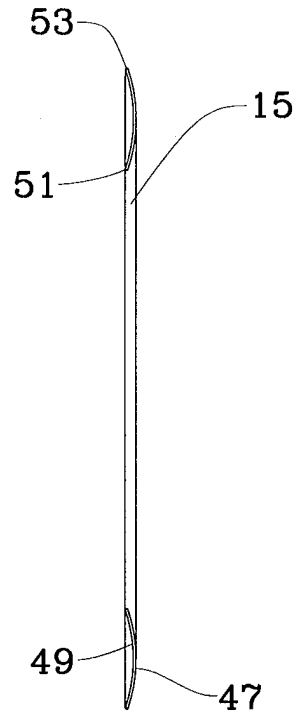
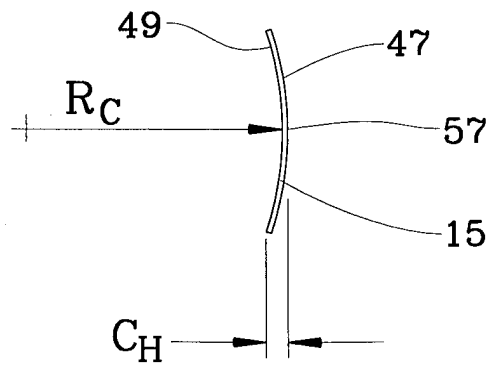

FIG. 13



INTERNATIONAL SEARCH REPORT

International application No.
PCT/US97/03352

A. CLASSIFICATION OF SUBJECT MATTER

IPC(6) : F16H 37/12; F16C 23/00

US CL : 475/216; 384/620; 476/42, 44

According to International Patent Classification (IPC) or to both national classification and IPC

B. FIELDS SEARCHED

Minimum documentation searched (classification system followed by classification symbols)

U.S. : 475/214, 215, 216, 218; 384/620; 476/10, 40, 42, 44, 45

Documentation searched other than minimum documentation to the extent that such documents are included in the fields searched

Electronic data base consulted during the international search (name of data base and, where practicable, search terms used)

C. DOCUMENTS CONSIDERED TO BE RELEVANT

Category*	Citation of document, with indication, where appropriate, of the relevant passages	Relevant to claim No.
X	US 4,464,952 A (STUBBS) 14 August 1984 (14.08.84), see the entire document	21-32, 35, 36, 38
A	US 5,540,631 A (LOHR et al) 30 July 1996 (30.07.96), see the entire document	40-64

Further documents are listed in the continuation of Box C.

See patent family annex.

* Special categories of cited documents:	"T" later document published after the international filing date or priority date and not in conflict with the application but cited to understand the principle or theory underlying the invention
"A" document defining the general state of the art which is not considered to be of particular relevance	"X" document of particular relevance; the claimed invention cannot be considered novel or cannot be considered to involve an inventive step when the document is taken alone
"E" earlier document published on or after the international filing date	"Y" document of particular relevance; the claimed invention cannot be considered to involve an inventive step when the document is combined with one or more other such documents, such combination being obvious to a person skilled in the art
"L" document which may throw doubts on priority claim(s) or which is cited to establish the publication date of another citation or other special reason (as specified)	"&" document member of the same patent family
"O" document referring to an oral disclosure, use, exhibition or other means	
"P" document published prior to the international filing date but later than the priority date claimed	

Date of the actual completion of the international search

06 JUNE 1997

Date of mailing of the international search report

21 JUL 1997

Name and mailing address of the ISA/US
Commissioner of Patents and Trademarks
Box PCT
Washington, D.C. 20231

Facsimile No. (703) 305-3230

Authorized officer

Dirk Wright
DIRK WRIGHT

Telephone No. (703) 308-2160