

(19) World Intellectual Property Organization
International Bureau



(43) International Publication Date
1 August 2002 (01.08.2002)

PCT

(10) International Publication Number
WO 02/058577 A1

(51) International Patent Classification⁷: A61B 18/08,
A61F 2/06

[RO/US]; 626 Drystack Way, Cary, NC 27513 (US).
KLEIN, Richard, Barry [US/US]; 107 Marseille Place,
Cary, NC 27511 (US).

(21) International Application Number: PCT/US01/47789

(74) Agent: RICHARDSON, Julie, H.; Myers Bigel Sibley &
Sajovec, P.O. Box 37428, Raleigh, NC 27627 (US).

(22) International Filing Date:
13 November 2001 (13.11.2001)

(25) Filing Language: English

(81) Designated States (national): AE, AG, AL, AM, AT, AU,
AZ, BA, BB, BG, BR, BY, BZ, CA, CH, CN, CO, CR, CU,
CZ, DE, DK, DM, DZ, EC, EE, ES, FI, GB, GD, GE, GH,
GM, HR, HU, ID, IL, IN, IS, JP, KE, KG, KP, KR, KZ, LC,
LK, LR, LS, LT, LU, LV, MA, MD, MG, MK, MN, MW,
MX, MZ, NO, NZ, PH, PL, PT, RO, RU, SD, SE, SG, SI,
SK, SL, TJ, TM, TR, TT, TZ, UA, UG, US, UZ, VN, YU,
ZA, ZW.

(26) Publication Language: English

(30) Priority Data:
60/248,109 13 November 2000 (13.11.2000) US

(71) Applicant (for all designated States except US): AR-
GOMED, LTD. [IL/IL]; 60 Medinat Hayehodim, P.O.
Box 399, 46103 Herzlia (IL).

(84) Designated States (regional): ARIPO patent (GH, GM,
KE, LS, MW, MZ, SD, SL, SZ, TZ, UG, ZW), Eurasian
patent (AM, AZ, BY, KG, KZ, MD, RU, TJ, TM), European
patent (AT, BE, CH, CY, DE, DK, ES, FI, FR, GB, GR, IE,

(72) Inventors; and
(75) Inventors/Applicants (for US only): CIONTA, Iulian

[Continued on next page]

(54) Title: HYPERTHERMY TREATMENT OF THE PROSTATE AND IMPLANTATION OF BIODEGRADABLE URETHRAL STENT

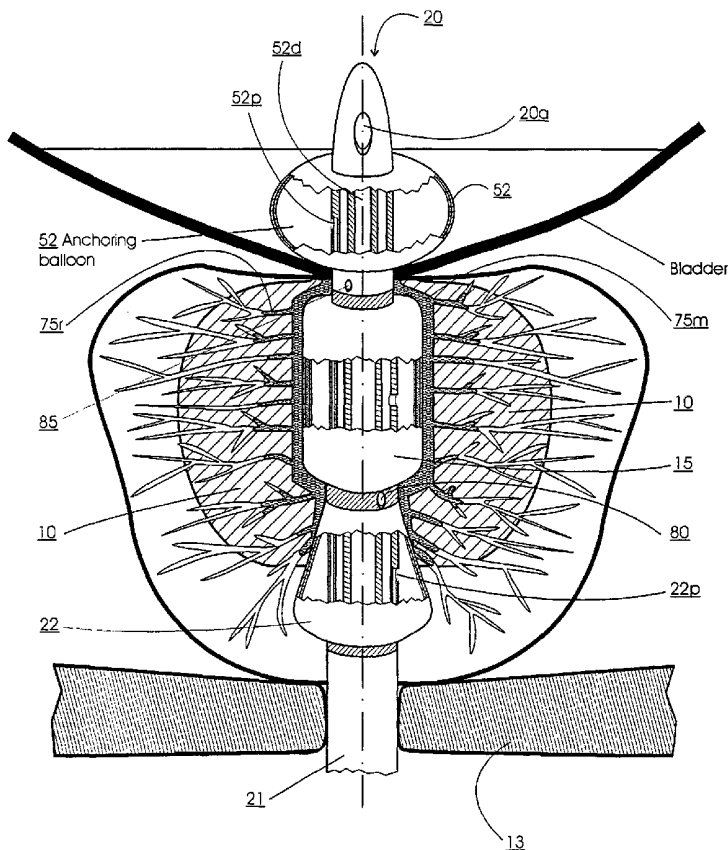

(57) Abstract: Methods of treating the prostate include administering a thermal ablation therapy and inhibiting the obstruction or closure of the prostatic urethral opening by forming a biodegradable stent in situ in the subject such that the stent attaches to the walls of the prostatic urethra. A related method of treating BPH includes thermally treating or ablating localized tissue in the prostate with a treatment catheter and inserting flowable stent material via the treatment catheter into the prostate (either before, during, or after the thermal treatment), forming the flowable stent material so that it defines a stent that remains in position after removal of the treatment catheter to inhibit the closure of the urinary passage. Associated stents and catheters are included.

WO 02/058577 A1



IT, LU, MC, NL, PT, SE, TR), OAPI patent (BF, BJ, CF, CG, CI, CM, GA, GN, GQ, GW, ML, MR, NE, SN, TD, TG).

— *before the expiration of the time limit for amending the claims and to be republished in the event of receipt of amendments*

Published:

— *with international search report*

For two-letter codes and other abbreviations, refer to the "Guidance Notes on Codes and Abbreviations" appearing at the beginning of each regular issue of the PCT Gazette.

HYPERTHERMY TREATMENT OF THE PROSTATE AND IMPLANTATION OF BIODEGRADABLE URETHRAL STENT

Related Applications

This application claims the benefit of priority from U.S. Provisional Application Serial No. 60/248,109 filed November 13, 2000, the contents of which are hereby incorporated by reference as if recited in full herein.

5

Field of the Invention

The present invention relates to methods for treating the prostate and/or prostatic urethral stents configured for use after thermal ablation treatments.

10

Background of the Invention

Conventionally, several types of thermal treatment systems have been proposed to treat certain pathologic conditions of the body by heating or thermally ablating targeted tissue. These thermal treatment systems have used various heating sources to generate the heat necessary to treat or ablate the targeted tissue. For example, laser, microwave, ultrasound, and radio-frequency (RF) energy sources have been proposed to produce the heat that is then directed to the targeted tissue in or around the selected body cavity. These types of thermal treatment systems have been used to thermally ablate the prostate (as well as other organs, body cavities, and/or natural lumens).

15

One particularly successful thermal ablation system thermally ablates the prostate by a thermocoagulation process. This thermal ablation system employs a closed loop liquid or water-induced thermotherapy (WIT) system which heats liquid, typically water, external to the body and then directs the circulating heated water into a treatment catheter which is inserted through the penile meatus and held in position in the subject undergoing treatment to expose localized tissue to ablation temperatures. The treatment catheter includes an upper end portion

20

25

which, in operation, is anchored against the bladder neck and an inflatable treatment segment which is held relative to the anchored upper end portion such that it resides along the desired treatment region of the prostate. In operation, the treatment segment expands, in response to the captured circulating fluid traveling therethrough, to press against the localized or targeted tissue in the prostate to expose the tissue to increased temperatures associated with the circulating liquid, thereby thermally ablating the tissue at the treatment site. In addition, the pressurized contact can reduce the heat sink effect attributed to blood circulation in the body, thus enhancing the depth penetration of the heat introduced by the inflatable treatment segment into the prostatic tissue.

As an acceptable alternative to surgery (transurethral resection of the prostate (TURP)), the use of WIT has been shown to be particularly suitable for the treatment of BPH (benign prostatic hyperplasia). Generally stated, the term "BPH" refers to a condition wherein the prostate gland enlarges and the prostatic tissue increases in density which can, unfortunately, tend to close off the urinary drainage path. This condition typically occurs in men as they age due to the physiological changes of the prostatic tissue (and bladder muscles) over time. To enlarge the opening in the prostatic urethra (without requiring surgical incision and removal of tissue), the circulating hot water is directed through the treatment catheter, which is inserted into the penile meatus up through the penile urethra and into the prostate as described above. The treatment segment expands with the hot water held therein to press the inflated treatment segment against the prostate, which then conductively heats and thermally ablates the prostatic tissue. The circulating water is typically heated to a temperature of about 60-62°C and the targeted tissue is thermally treated for a period of about 45 minutes to locally kill the tissue proximate the urinary drainage passage in the prostate and thereby enlarge the urinary passage through the prostate.

Subsequent to the delivery of the thermal ablation treatment, the treated tissue in the prostate undergoes a healing process. Initially, the ablated tissue can expand or swell due to inflammation or edema which can undesirably block or obstruct the prostatic urethra. Further, during the healing period, portions of the treated tissue can slough off and create an undesirable and unduly limited opening size. Thus, to facilitate proper healing and to enhance the efficacy of the ablation

therapy, either the treatment catheter is left in the subject for a period of time and/or the treatment catheter is removed and a post-treatment catheter, such as a conventional Foley catheter, is reinserted and positioned in the subject. However, removal of the treatment catheter and reinsertion of another catheter or stent may
5 cause the tissue along the insertion path and/or treatment region to experience additional irritation. In addition, the amount of time that the treatment or post-treatment catheter must reside in the subject can be from 2-14 days, or even longer. Therefore, it is desirable to configure the post-treatment stent in a minimally
10 invasive manner to allow normal operation of the sphincter, remove the need for the use of an incontinence bag, and reduce the inconvenience or discomfort to the user.

Conventionally, Foley-type catheters with bladder anchoring balloons located on an upper end portion have been used as post-treatment catheters to allow the thermally ablated tissue to mold around the catheter perimeter during the
15 initial healing phase. While these type catheters allow the post-treatment catheter to be securely positioned relative to the bladder neck of the subject, natural operation of the sphincter is inhibited, and the configuration is relatively cumbersome (in position it extends through the penile urethra) and can be considered unduly invasive by the user and may increase the risk of urinary tract
20 infection (UTI) when in position in the subject (particularly, when used for extended periods of time). Other post-treatment catheter configurations (also known as "indwelling catheters" and "stents") have also been proposed; however, some of the catheter types can inhibit the ability to flush out blood clots which may exist from the therapy, and others are undesirably invasive to the user and/or
25 prevent or inhibit the natural operation of the sphincter. Still others are not able to be properly located within the prostatic cavity about the treatment region and/or are unable to retain their desired position in the prostate over time. Still others can, during prolonged use, promote muscle atrophy and/or localized tissue necrosis.

Examples of known post-treatment catheters or stents are described in U.S.
30 Patent Nos. 5,916,195 to Eshel et al., 5,876,417 and 5,766,209 to Devonec et al., and 3,811,450 to Lord. However, there remains a need to provide improved and/or minimally invasive stents and/or post-treatment catheters or stents that are cost effective and can be positioned in the body, such as in the prostate, proximate the

5 treated tissue, to inhibit the restriction of the cavity or natural lumen. There remains a particular need to provide a prostatic stent that is suitable for use during a post thermal therapeutic treatment (such as ablation) healing process or cycle that can inhibit the closure of the urethra in a manner that reduces abrasion, trauma, or irritation that may be introduced to sensitive tissue along the urethra over conventional treatment procedures.

Objects and Summary of the Invention

10 It is therefore an object of the present invention to provide a biodegradable and/or biocompatible prostatic stent that that can be formed *in situ* via use of the treatment catheter and is suitable for inhibiting post thermal ablation therapy obstruction in the prostate.

15 It is another object of the present invention to provide methods to inhibit obstruction in an intermittent or periodic flow passage of natural cavities or lumens in the body to keep the flow passage sufficiently open such that the subject is able to discharge or intake fluids in a substantially normal manner.

20 It is another object of the present invention to deliver flowable stent material into the patient via the treatment catheter and then to form the stent to conform and be in intimate contact with the walls of the prostatic urethra *in situ* so as to inhibit obstruction in a lumen or cavity during a healing cycle.

25 These and other objects are satisfied by the present invention that provides, *inter alia*, methods for treating the prostate and concurrently forming biocompatible and/or biodegradable stents in the urethra during the same treatment session. In particular embodiments, the stent can be delivered and formed in the prostatic urethra so that it resides above the sphincter, and below the bladder neck, and more particularly, substantially between the bladder neck and the verumontanum. Similarly, the present invention includes methods of treating BPH (and other prostate conditions) in a manner that inhibits obstruction in the prostatic urethra during a healing period after a thermal ablation treatment therapy.

30 Certain embodiments of the present invention are directed to methods of treating a condition of the prostate and forming a prostatic stent *in situ* in the prostatic urethra. The method includes: (a) introducing a catheter having an expandable treatment balloon thereon into the male urethra of the subject so that

the treatment balloon resides proximate the prostatic urethra; (b) administering a thermal ablation therapy to the prostatic urethra of the subject via the treatment catheter, wherein the thermal ablation therapy has a duration of at least about 10 minutes; (c) releasing biocompatible biodegradable fluent stent material from the catheter; (d) pressing the fluent stent material into intimate contact with the interior surface of the prostatic urethra by using the expandable treatment balloon; (e) activating the biocompatible stent material *in situ* to cause it to attach and conform to the interior surface of the prostatic urethra so as to take on a non-fluent form to define a stent having sufficient strength and/or thickness to inhibit closure of the prostatic urethra after administration of the thermal therapy; and (f) then removing the treatment catheter leaving the stent in position in the prostatic urethra.

In other embodiments, the pressing step is optional.

Other embodiments are directed to methods of treating BPH. The methods include: (a) thermally ablating localized tissue in the prostate with a treatment catheter having an expandable treatment balloon thereon; (b) flowing fluent viscous or semi-viscous biocompatible and biodegradable stent material from the treatment catheter into the prostate; (c) molding the flowable stent material to contact the interior surface of the prostatic urethra by expanding the treatment balloon to press the stent material away from the treatment balloon toward the interior surface of the prostatic urethra; (d) securing the stent material to the prostatic urethra so that it defines a resilient conformable stent that remains in position after removal of the treatment catheter to inhibit the closure of the urinary passage; and (e) removing the treatment catheter from the body of the subject.

Other embodiments of the present invention are directed to catheters for treating a condition of the prostate. The catheter includes: (a) an elongated axially extending shaft; (b) a treatment balloon secured to the shaft and configured to expand outwardly therefrom, the treatment balloon configured to apply a thermal therapy to targeted tissue in the body; (c) a bladder anchoring balloon secured to the shaft above the treatment balloon and configured to expand outwardly from the shaft (that can, in certain embodiments, also substantially securely contact the tissue to define a seal about the upper region above the treatment balloon); (d) a sealing balloon secured to the shaft below the treatment balloon and configured to expand outwardly from the shaft; (e) a urinary drainage channel extending through

the shaft; and (f) a flowable biocompatible and biodegradable stent material channel having at least one ejection port formed in the shaft associated therewith, the flowable material channel being in fluid isolation with the drainage channel. The shaft is configured and sized such that the portion intermediate the treatment
5 balloon and anchoring balloon has a decreased cross-sectional width relative to the portion of the shaft intermediate the treatment balloon and sealing balloon thereby allowing easy extraction of the catheter after the stent is formed. In operation, the sealing balloon and the bladder-anchoring balloon are in an expanded configuration when flowable biodegradable stent material is directed to exit the
10 ejection port.

In particular embodiments, the catheter can include at least one flushing port and associated flushing channel disposed in the shaft above the at least one dispersing and/or ejection port. In operation, the flushing port is configured to receive flowable stent material therein and direct it to flow out of the body of the
15 subject in the flushing channel to thereby allow a clinician to verify that the flowable stent material has traveled about the prostatic urethra. A sufficient quantity of flowable stent material can be introduced so as to substantially fill the cavity between the treatment balloon and the walls of the prostatic urethra. In addition, the flushing port may be configured to have a reduced size relative to the
20 ejection/dispersing port to facilitate proper filling of the cavity.

Other embodiments include catheters for treating a condition of the prostate that include (a) an elongated axially extending shaft; (b) a treatment balloon secured to the shaft and configured to expand outwardly therefrom; (c) a bladder anchoring balloon secured to the shaft above the treatment balloon and configured
25 to expand outwardly from the shaft; (d) a urinary drainage channel extending through the shaft; and (f) a non-fluent transformable biodegradable and biocompatible stent material layer formed over the outer surface of the treatment balloon, whereby when exposed to predetermined temperatures, the stent material is configured to become fluent and released from the treatment balloon to flow to
30 surrounding regions in the prostatic urethra and then, upon exposure to different predetermined temperatures, is configured to become non-fluent and remain in intimate contact with the interior surface of the prostatic urethra to define biocompatible biodegradable stent.

In particular embodiments, the shaft is configured and sized such that the portion intermediate the treatment balloon and anchoring balloon has a decreased cross-sectional width relative to the portion of the shaft immediately below the treatment balloon to allow for ease of extraction of the catheter after the stent is formed *in situ*.

Other catheters include: (a) an elongated axially extending shaft; (b) a treatment balloon secured to the shaft and configured to expand outwardly therefrom; (c) an outwardly expandable permeable or porous sleeve configured to overlie the treatment balloon, the sleeve being independently inflatable from the treatment balloon; (d) a quantity of flowable biocompatible biodegradable stent material disposed intermediate the treatment balloon and the sleeve; (e) a bladder anchoring balloon secured to the shaft above the treatment balloon and configured to expand outwardly from the shaft; (f) a sealing balloon secured to the shaft below the treatment balloon and configured to expand outwardly from the shaft; (f) a urinary drainage channel extending through the shaft; and (g) a flowable fluent biocompatible stent material channel having at least one ejection port formed in the shaft in fluid communication with the sleeve so as to direct the flowable biocompatible stent material therein, the flowable material channel being in fluid isolation with the drainage channel. In operation, the treatment balloon is adapted to inflate to press the flowable stent material released from the sleeve into the targeted tissue in the body.

Still other embodiments are directed to biodegradable stents for the prostatic urethra. The stent is defined by a non-fluent biodegradable biocompatible polymeric material that is in intimate contact with tissue on the surface of the prostatic urethra and extends a distance into a plurality of the acini (prostate ducts), the biodegradable stent having sufficient thickness and length to inhibit closure of the urinary flow passage through the prostatic urethra. The stent may be employed post-treatment (to attach to ablated tissue) or for hyperplasia or other prostate or urinary tract conditions.

Another aspect of the present invention is a set of prostatic treatment catheters, each configured for insertion into the male urethra of a subject as stated above. However, the set is provided such that each is sized a different length to allow customized fit to a particular subject (the portion of the stent body which is

adapted to reside in the prostatic urethra itself).

Advantageously, the present invention provides catheters, methods, and/or post-treatment biocompatible stents that can be delivered via the treatment catheter (before, during, or after active administration of the treatment) in a treatment session so as to inhibit prostate obstruction in the urinary drainage path during post-treatment healing. The stents can be made to be biodegradable (that includes bioabsorbable and the like) and configured to reside in the subject above the sphincter during the healing cycle. As the ablated tissue is sloughed off the surface, the stent will be absorbed or discharged from the body. In certain embodiments, the stent will be gradually absorbed and/or flushed out of the subject over about 3 weeks -6 months. In operation, the stent can be configured so as to have sufficient thickness and resilience to allow drainage and/or flushing liquids to be directed into the subject therethrough even for a patient undergoing increased internal pressures due to edema during a healing period after a thermal ablation therapy has been applied to a localized region of the prostate. The instant invention can also reduce irritation introduced to the ablated tissue (which can reduce the number of blood clots produced by the subject) over conventional procedures by eliminating the requirement of inserting a physical conventional mechanical type stent.

20

Brief Description of the Drawings

The accompanying drawings, which are incorporated in and constitute a part of the specification, illustrate embodiments of the invention and, together with the description, serve to explain principles of the invention.

Figure 1A is a schematic illustration of the anatomy of the male urethra showing a treatment catheter and a thermal ablation treatment region in the prostate according to embodiments of the present invention.

Figure 1B is a greatly enlarged partial front view of a treatment catheter according to embodiments of the present invention illustrating the release of flowable biocompatible biodegradable stent material while in position in the subject.

30

Figure 1C is a schematic view of an ablated region of the prostate with a biocompatible biodegradable stent according to embodiments of the present

invention in position in the subject after removal of the treatment catheter so as to be in intimate contact with the ablated tissue.

Figure 2A is a sectional view of the prostate illustrating the ablated tissue with the biocompatible biodegradable stent according to embodiments of the present invention secured to the ablated tissue to inhibit closure of the prostatic urethra.

Figure 2B is a sectional view of the prostate illustrating the ablated tissue with a biocompatible biodegradable stent according to embodiments of the present invention secured to the ablated tissue and in the acini ducts to thereby bolster the structural integrity of the stent.

Figure 3 is a schematic illustration of a closed loop circulating fluid system according to embodiments of the present invention that is configured to both thermally ablate the targeted tissue and deliver and conform the biocompatible biodegradable stent material to the walls of the prostatic urethra.

Figure 4 is a block diagram of operations suitable for carrying out embodiments of the present invention.

Figure 5A is a perspective view of a treatment catheter according to embodiments of the present invention configured to deliver and apply the biocompatible biodegradable stent to the targeted region in the body.

Figure 5B is a front view of a treatment catheter according to other embodiments of the present invention.

Figure 6A is a front view of another treatment catheter according to other embodiments of the present invention configured to provide the biocompatible biodegradable stent.

Figure 6B is a sectional view of a treatment catheter taken along lines **6B-6B** of **Figure 6A** according to embodiments of the present invention.

Figure 6C is a sectional view of a treatment catheter taken along lines **6C-6C** of **Figure 6A** according to embodiments of the present invention.

Figure 6D is an alternate configuration of the sectional view shown in **Figure 6B** according to embodiments of the present invention.

Figure 7 is a partial side section view of a treatment catheter and flowable stent material injection device according to embodiments of the present invention.

Figure 8 is a front view of a treatment catheter according to embodiments of the present invention in position in the body and contacting and pressing the biocompatible biodegradable stent material proximate thereto.

5 **Figures 9A-9D** are graphs of the operative temperatures over time for treatment sessions according to embodiments of the present invention using treatment systems to deliver thermal ablation treatments as well as biocompatible biodegradable stents according to embodiments of the activation temperatures.

10 **Figures 10A-10E** illustrate operative configurations of an exemplary treatment catheter according to embodiments of the present invention during use in the subject.

Figure 11 is a front partial view of a set of treatment catheters according to embodiments of the present invention.

Detailed Description of Embodiments of the Invention

15 The present invention now will be described more fully hereinafter with reference to the accompanying drawings, in which embodiments of the invention are shown. This invention may, however, be embodied in many different forms and should not be construed as limited to the embodiments set forth herein; rather, these embodiments are provided so that this disclosure will be thorough and
20 complete, and will fully convey the scope of the invention to those skilled in the art. In the figures, certain elements or features may be exaggerated for clarity and broken lines indicate optional features and/or operations. Like numbers refer to like elements throughout.

25 The term “thermal ablation” refers to exposing the targeted tissue to a temperature that is sufficient to kill the tissue. In certain embodiments, the thermal ablation is carried out by exposing the targeted tissue to thermocoagulation via a catheter inserted into the subject which is configured to direct circulating hot liquid that is held captured in the catheter and treatment balloon, and which is heated
30 external of the body of the subject, to the targeted treatment region. In any event, in operation, the targeted tissue is exposed to an elevated temperature that is greater than or equal to about 45°C for a predetermined period of time. In other embodiments, other treatment types can also be used such as surgical resection or other thermal therapies, particularly those that can generate inflammation in the

body. The catheters or methods employing biodegradable biocompatible stents according to the present invention may also be appropriate for use in other treated natural lumens or body cavities having intermittent or periodic flow (into, out of, or through) such as the colon, the uterus, the cervix, the throat, the respiratory passages, the ear, the nose, and the like, to inhibit closure or restriction thereof.

In certain embodiments, the thermal ablation is directed to treating conditions of the prostate such as cancer and/or BPH. In so doing, the prostatic tissue can be exposed to a temperature that is at or above 50°C-62°C for a treatment period that is typically about 10-60 minutes or longer, and typically between about 20-60 minutes in duration. In certain embodiments, the treatment temperature can be at about 60°C-62°C. In other embodiments, temperatures of 45°C-50°C may be used. Combinations of different ablation level temperatures with different associated and/or cumulative durations may also be employed.

Referring now to the figures, the treatment catheter **20** shown in **Figure 1A**, may be configured to supply the ablation therapy with any desired suitable heating source including RF, microwave, laser, ultrasound, circulating heated fluid, resistive heating, and the like. The heat can be directed at the tissue proximate the (expanded) treatment balloon. Employing circulating heated fluid may be particularly suitable for administering the thermal ablation procedure and also to activate and form the biocompatible stent **75 in situ**.

As shown in **Figure 1A**, thermal ablation therapy be carried out in a localized treatment region within the prostatic urethra, the treatment region **10** being generally described as including the upper portion of the urethra (termed the prostatic urethra) so as to extend generally below the bladder neck and above the verumontanum **11b** of the subject. Alternatively, the treatment region **10** may include the bladder neck or a portion of the bladder neck itself. A suitable thermal treatment system is available from ArgoMed, Inc. located in Cary, North Carolina. *See also*, U.S. Patent Nos. 5,257,977 and 5,549,559 to Eshel, and co-assigned U.S. Patent Application Serial No. 09/433,952 to Eshel et al, the contents of which are hereby incorporated by reference as if recited in full herein.

Referring again to **Figure 1A**, the thermal ablation treatment region **10** is indicated by the shaded lined region in the prostate above the sphincter **13**. In operation, an elongated flexible treatment catheter **20** with an outwardly

expandable treatment balloon **15** is inserted into the penile meatus along the penile urethra and positioned in the prostatic urethra and secured so that the treatment balloon **15** resides at the desired targeted tissue. In this embodiment, the treatment catheter **20** includes an axially extending shaft **21** and a urine discharge port **20e** that is in fluid communication with a urine discharge or drainage channel **52d** that allows urine to drain from the bladder through the catheter **20** while the catheter is in the subject. The treatment catheter **20** also includes a bladder anchoring balloon **52**, the outwardly expandable treatment balloon **15**, and, in certain embodiments, a lower blocking balloon **22**. The treatment balloon **15** is configured to reside proximate the prostatic urethra above the membranous urethra. The lower blocking balloon **22**, when used, is configured to reside above the urinary sphincter **13** in the membraneous urethra (and proximate the verumontanum). The treatment catheter **20** is also configured to supply and form *in situ* a biodegradable biocompatible stent **75** (shown as a stent layer **75l** in **Figure 1A**) that has selective fluent and non-fluent states to the treated region. Upon removal of the catheter **20** from the subject, the stent **75** remains in position in a non-fluent state (**Figure 1C**) and in intimate contact with the prostatic urethra so as to inhibit closure of the prostatic urethra during edema or post-healing inflammation or swelling (as indicated by the lateral inwardly oriented arrows shown in **Figure 10E**).

As shown in **Figures 1C, 2A, and 2B**, in certain embodiments, the stent **75** is conformably formed and resiliently configured such that it can follow the contours of the urethra and provide a substantially smooth exposed inner surface while having sufficient rigidity to maintain a sufficiently sized opening in the prostatic urethra treatment region to allow urine drainage during the healing period. In particular embodiments, the stent **75** is configured so as to have good mechanical biocompatibility to sustain a desired opening size **75d** (**Figure 2A**) but sufficiently compliant so as to reduce the likelihood of introducing injury or shearing the proximate tissue.

As such, the stent **75** can be formed of a suitable material and thickness **75th** as to be able to maintain a desirable opening size in the prostatic urethra lumen when exposed to compressive swelling pressures in the localized treatment region. Typically the stent body is able to maintain a sufficient opening size when exposed to compressive pressures from the treated tissue, these pressures may be

on the order of about 7-21 psi. In certain embodiments, as illustrated in **Figure 1C** and **2B**, the stent **75** has a thickness **75th** of between about 1-3 mm (on average) along the length of the prostate proximate the location of the treatment balloon **15**.

The stent **75** may provide increased size for the prostatic urethra to discharge urine over the use of conventional Foley type catheters during the first 0-72 hours post-treatment. In certain embodiments, the stent **75** when formed against the urethra walls can be configured to define an inner diameter and corresponding opening width **75d** of about 5-25 mm, and typically about 10-20 mm.

In the fluent state, the flowable stent material **75m** (**Figure 1B**) is typically a viscous or semi-viscous fluidic material that can be released from the catheter **20** to be able to disperse, travel or migrate away from the catheter to contact the walls of the prostatic urethra. The stent material **75m** that forms the stent can be delivered to the prostatic tissue before, during, or after (but proximate in time to) the administration of the thermal ablation therapy. The treatment balloon **15** may be used to press, shape, or form the fluent stent material **75m** against the wall. Once formed and/or in position in the body, the flowable stent material can be activated or transformed into the non-fluent state to conform to the inner surface of the prostatic urethra. In certain embodiments, the stent material **75m**, stent layer **75l** and/or stent **75** can be formed so as to be a good heat conductor. The term “good heat conductor” means that at ablation temperatures, the temperature drop across the stent or stent material is about 0.5 degrees or less.

Examples of suitable flowable biocompatible biodegradable stent materials that have fluent and non-fluent selectively transformable states are well known and include, but are not limited to, biodegradable biocompatible polymeric materials including polymers and copolymers and mixtures thereof. As used herein, the term “biodegradable” can include bioabsorbable and/or bioerodable or biodischargeable materials that are non-permanent and removed by natural or imposed physiological, biological, chemical or therapeutic processes. For more description of examples of suitable polymeric materials, *see* U.S. Patent Nos. 4,702,917; 5,634,946; 5,575,815; 5,674,287; and 5,674,192; the contents of which are hereby incorporated by reference as if recited in full herein. The polymeric materials may also include other additives such as plasticizers, medicaments and the like.

In certain embodiments, material compositions that include polycaprolactones may be particularly suitable as a bioabsorbable polymer that can be selectively formulated and/or configured for a relatively short degradation process in the body of between about 2 weeks to five or six months, and typically about 2 weeks to about 2 months, by selecting the proper composition, formulation, or formation method (such as by adjusting through copolymerization).

The polycaprolactone has a crystalline melting point of 60 °C. It is noted that polyanhydrides have been described as suitable for drug matrix delivery and have relatively low glass transition temperatures (such as near body temperature).

The stent material **75m** may comprise medicaments such as therapeutic or symptomatic treatment substances, pharmaceutical agents or drugs, bioactive substances, or food supplements, and the like, used to treat conditions of the prostate (such as BPH) or its symptoms that can be suspended as a matrix in the stent **75** and released in a time matrix format to facilitate the healing process and/or the treatment of the prostate. The medicaments can be ejected from the catheter before, during, or after the positioning of the fluent stent material **75m** in the prostatic urethra either before, after, or during the transformation of the stent material to the non-fluent state. Examples of medicaments will be discussed further below.

In certain embodiments, such as in the configurations where the stent material **75m** or stent **75** is positioned in the conductive heat path during the thermal ablation therapy, the material **75m** can be formulated to be a good thermal conductor to allow for sufficient penetration of heat beyond the stent **75** and into the underlying prostatic tissue. As such, the stent material **75m** can be selected so that it solidifies or becomes non-fluent at a desired time before, during, or after the thermal ablation treatment so as to not unduly interfere with the thermal ablation treatment, and then remains behind in the body after treatment and removal of the catheter **20**.

The stent material **75m** can be delivered to the target site in a fluent or non-fluent state and then subsequently released thereto before, during, or after the thermal ablation therapy in a number of different manners using a treatment catheter. For example, as shown in **Figure 1A**, the stent material can be configured as a non-fluent outer shell or layer **75I** disposed over the outer surface

of the treatment balloon **15** on the catheter **20** so that, upon insertion, the stent layer **75l** remains on the treatment balloon until a desired release time at which point it is transformed into a fluent state as will be discussed further below.

In certain embodiments, as shown in **Figure 1B**, the stent material **75m** can be introduced into the prostatic urethra so that it is able to travel a distance into the acini (prostate ducts or channels) in the prostate to form anchors or roots **75r** (see also **Figure 1C**) to help secure the stent **75** into the tissue in the body so that it has increased structural reinforcement capability). Introducing the stent material **75m** with sufficient pressure and/or at a time during the thermal treatment can allow the stent material **75m** to migrate into the channels to form roots or anchors **75r**. In some embodiments, an internal massage therapy can be administered concurrently or serially with the thermal ablation therapy (such as by repetitively successively expanding and contracting the treatment balloon) at a time before or during the thermal ablation process. See co-pending and co-assigned U.S. Provisional Patent Application Serial No. 60/308,344, the contents of which are hereby incorporated by reference as if recited in full herein.

In yet other embodiments, as shown in **Figure 5B**, the fluent stent material **75m** can be directed to exit a permeable or porous sleeve **15s** that is positioned over the treatment balloon **15**. The sleeve **15s** can be configured to be concurrently expandable with the treatment balloon as well as independently expandable responsive to the quantity of fluent stent material **75m** that is directed to flow from the sleeve inlet port **16p** and associated flow channel **16c**. The sleeve **15** may be configured as a low thermal resistance elastic sleeve that helps the catheter maintain a low profile upon insertion and removal to force the treatment balloon tightly against the surface of the shaft, even after exposure to ablation level temperatures. The sleeve **15s** is elastic and can be formed from an elastomeric material having a Shore A (Type A) durometer range of between about 20 and about 60. The thickness of the elastic sleeve **15s** can, in certain embodiments, be between about 0.005 inches and about 0.030 inches (about 0.127-0.762 mm). Typically, the sleeve **15s** should be configured so as to not substantially interfere with the heat transfer from the underlying treatment balloon **15** during the thermal ablation treatment. Elastomeric materials that may be suitable to form the sleeve **15s** include, but are not limited to, silicone, natural rubber, synthetic rubber, and

plasticized polyvinylchloride (PVC). In certain embodiments, the permeable or porous sleeve **15s** may be used in combination with the dispersing and/or flushing ports and channels as desired.

In particular embodiments, the sleeve **15s** may also be formed of
5 biodegradable materials. For the biodegradable materials, the sleeve **15s** (or a portion thereof) may be configured such that it is absorbed into the body over time or so that it dissolves after it enters the body at some point in time before, during, or after the treatment. As such, in certain particular embodiments, the sleeve **15s** may be used to form the stent **75**. Examples of suitable biodegradable materials
10 include polymers, copolymers and polymer compositions. Exemplary biocompatible biodegradable absorbable materials were described above and others are described in U.S. Pat. Nos. 6,171,338; 4,743,257; 4,700,704; 4,655,497; 4,649,921; 4,559,945; 4,532,928; 4,605,730; 4,441,496; 4,435,590; and 4,559,945.

The contents of these patents are hereby incorporated by reference as if recited in
15 full herein. Additional description of suitable sleeves can be found in co-pending and co-assigned U.S. Provisional Application Serial No. 60/288,774, the contents of which are hereby incorporated by reference as if recited in full herein.

In other embodiments, as shown in **Figure 1B**, fluent stent material **75m** is flowably directed up in the catheter via one or more flow channels so that it travels
20 through the catheter **20** to be released from one or more injection or dispersing apertures **80** formed in the outer wall of the catheter **20** about the treatment region.

The at least one dispersing aperture **80** may be positioned in the shaft **21** above and/or below the treatment balloon **15** and includes an associated material flow channel **80c** (**Figures 5A, 6B**). A plurality of spatially separated dispersing
25 apertures **80** may be used, each in fluid communication with a common or individual flow channel. In certain embodiments, at least one (or a plurality of radially spaced) dispersing apertures **80** can be positioned both above and below the treatment balloon **15** so that a sufficient quantity of fluent stent material **75m** can be distributed and/or sprayed about the prostatic urethra as shown in **Figure**
30 **10C**.

In certain embodiments, as shown in **Figure 1B**, one or more dispersing or injection apertures **80** may be positioned below the treatment balloon **15** and one or more flushing apertures **85**, each having a common, shared, or separate associated

flushing channel, can be located above the treatment balloon **15**. The treatment balloon **15** may be partially or wholly deflated when the stent material **75m** is ejected from the dispersing ports **80**. The stent material **75m** can be forcibly ejected from the dispersing ports **80** under pressure such that the stent material

5 **75m** rises to the location proximate the flushing port **85**. The upper flushing port **85** may be sized and configured to be smaller than the dispersing port **80** so as to impede or reduce the amount of stent material **75m** that flows therein (thereby keeping a substantial or major portion of the material **75m** in the prostatic urethra). In particular embodiments, the flushing port **85** may be from about 10-75% smaller

10 in width than the dispersing port **80**. In operation, a quantity of stent material **75m** will then enter the flushing port **85** and travel through the associated flushing channel **85c** (**Figures 5A, 6C**) to exit the catheter **20**. A clinician can monitor the external orifice of the flushing channel **85c** to determine when/if sufficient quantity of fluent stent material **75m** has been distributed and/or circulated or delivered *in*

15 *vivo* based on the confirmation that a suitable quantity has exited the catheter via the flushing channel(s) **85c** (that is in fluid isolation from the flow channel (s) **80c**). The external orifice of the channel (such as via flexible tubing **18t**) associated with the flushing port **85** can be closed or blocked off (with a valve means or plug) **85p** after sufficient quantity has exited the catheter to terminate excess leakage of

20 stent material **75m** from the body as shown in **Figure 3**.

Although not required, in certain embodiments as shown in **Figure 1B, 5A, and 6A**, the treatment catheter **20** may also include a lower sealing balloon **22**. Prior to releasing the stent material **75m** in fluent form from the catheter, the sealing balloon **22** can be expanded to contact the walls of the membranous

25 urethra to substantially seal the urethra above the sphincter. In this manner, the stent material **75m** is inhibited from flowing below the sealing balloon **22**. The sealing balloon **22** can be concurrently inflatable with the treatment balloon **15** (in fluid communication therewith) or separately inflatable having its own inflation channel, inflation port and source.

30 As shown in **Figure 1A**, the sealing balloon **22** can be configured to take on a shape that can be described as a pear shape, ramped or inclined shape, or frusto-conical shape, when expanded. This allows the profile of the sealing balloon **22** to taper out from the top to the bottom, thereby inhibiting movement of

the catheter **20** toward the sphincter **13** when the sphincter **13** relaxes or opens. In addition, this shape may also inhibit upward movement of the catheter body toward the bladder, as the upper portion of the prostatic urethra, especially when the treated tissue is swollen, inflamed or suffering from edema, tends to close
5 down or restrict the opening area in this region. Thus, the sealing balloon **22**, which can be positioned in the in the membranous urethra, will abut the restricted opening size of the urethral canal thereabove, in the treatment region, thereby inhibiting upward movement or migration of the catheter **20**. Of course, the present invention is not limited thereto and other balloon shapes may also be
10 employed, as may corresponding elastic sleeves with various shapes and configurations including, but not limited to, pear shapes, ramped or inclined shapes, bulbous shapes, elliptical shapes, oval shapes, cylindrical shapes, accordion pleated shapes, shapes with tapered fins (such as circumferentially disposed about the perimeter of the lower portion of the stent body), and the like.
15 Similarly, the anchoring balloon **52** may be configured in any suitable shape.

In operation, and independent of the delivery mechanism or configuration, the fluent material **75m** can be pressed against the wall or interior surface of the prostatic urethra by the expansion of the treatment balloon **15** and then transformed into a non-fluent state by exposing the stent material **75m** to an activation
20 mechanism or reaction source such as chemical (polymerization or cross-linking), electrical, or mechanical, including, but not limited to, heating, cooling, or exposing the fluent material **75m** to light *in situ*.

In other embodiments, two different fluent materials or material mixtures (one containing the initiator) can be directed to travel through the catheter in fluid
25 isolation and ejected from the catheter separately under pressure so that they mix *in situ* to react to transform the combined mixture into the biocompatible biodegradable non-fluent stent. One of the materials or material mixtures may be directed to exit the catheter through the porous or permeable sleeve **15s**, or each may have its own ejection channel and port.

As shown in **Figure 5A**, the lower portion of the shaft **211** of the catheter
30 can include elongated channels **21c** that can function as fluid flow channels (such as channels **80c** and/or **85c** that are in fluid communication with injecting/dispersing aperture **80** and flushing aperture **85**, respectively) and/or can

provide increased shaft insulation **21i** that encases one or more internal fluid lumens **21c** (such as the drainage channel **52d**, and/or inlet and outlet circulating fluid channels **26i**, **26o** or other desired flow paths) as desired for particular embodiments of the invention. As shown, the increased insulation **21i** can include
5 a number of axially extending channels that encase the inner lumens. See co-assigned concurrently filed U.S. Application Serial No. XXX, entitled *Treatment Catheters with Thermally Insulated Regions*, identified by Attorney Docket No. 9149-16 for additional description of catheter insulation configurations, the contents of which are hereby incorporated by reference as if recited in full herein.

10 **Figure 6A** illustrates another embodiment of a catheter **20** that can be configured to be conformable to the contours of the urethra upon insertion and includes a plurality of elongated channels **21c** that define increased insulation **21i** for a lower portion of the shaft **21**. **Figures 6B** and **6D** illustrate different elongated outer and inner channel configurations (and/or wall structures). As
15 shown, one of these channels **21c** is the fluid material flow channel **80c**. Other of the channels **21c** can be used to inflate the anchoring balloon **52** and the sealing balloon **22** (and may also be used to supply the sleeve with fluid material or to direct medicaments to the treatment region where desired). The elongated channels **21c** encase internal fluid lumens such as the drainage channel **52d** and the
20 inlet and outlet fluid circulating channels **26i**, **26o**, respectively. **Figure 6C** illustrates a different view taken about the flushing port. As shown, one of the elongated channels **21c**, is in fluid communication with the flushing port **85** and provides the associated flushing channel **85c**.

25 **Figure 8** illustrates the treatment catheter **20** in position in the subject with the stent material **75m** released therefrom and positioned about the prostatic urethra. As shown, the stent material **75m** extends an axial length that corresponds to the distance between the lower portion of the anchoring balloon **52** and the upper portion of the sealing balloon **22**.

30 **Figure 7** illustrates that a syringe **96** with a quantity of stent material **75m** that may be used to engage with the desired flow channel(s) in the catheter to deliver the stent material to the dispersing port(s) **80** (and/or to flow channel **16c** then to sleeve port **16p**) under pressure. An exemplary quantity of stent material **75m** that may be deployed to form the suitable stent thickness and size, includes,

but is not limited to, at least about 20 ml-100 ml. The syringe **96** may be manually operated or automatically operated such as via a stepper motor **96m** that automatically translates the plunger **96p** of the syringe **96** to inject the stent material under pressure. A pressure sensor (not shown) may be employed to allow
5 a controlled pressure release as desired.

Figures 9A-9D illustrate examples of temperature cycles over a treatment session that can be used to administer a thermal ablation therapy and to transform the stent material **75m** to its desired fluent and/or non-fluent forms during, before, or after the thermal ablation therapy. **Figure 9A** illustrates that the stent material
10 can be released or placed into the prostate before the thermal therapy and the thermal ablation therapy can be administered at a substantially constant temperature of between about 50-60°C (for a time “T1”). As such, the ablation energy travels through the stent **75** such that it either becomes non-fluent early in the ablation treatment session or becomes non-fluent when the temperature is
15 ramped down to body temperature at the end of the treatment session.

Figure 9B illustrates that the treatment can be carried out a first ablation temperature threshold for a major portion of the therapeutic treatment (“T1”) and then elevated to a second increased temperature toward the end of the treatment session (“T2). In this embodiment, the stent material **75m** may be located in the
20 body prior to the initiation of the treatment (such as an outer layer on the treatment balloon **15**) but the stent **75** does not become non-fluent until after the time designated as “T1” when it reaches its activation threshold.

Figure 9C illustrates that the ablation therapy can be carried out and then the stent material **75m** cooled at time T2 to cause it to become non-fluent. The
25 stent material can be introduced between times T1 and T2 or during or before T1.

Figure 9D illustrates that the thermal ablation therapy can be carried out at a first threshold level similar to **Figure 9B**, and after the thermal therapy is completed, the thermal source is interrupted to insert the flowable material into the prostatic urethra. Then an activation thermal cycle can be commenced during time
30 and a second selected temperature “T2” to transform the stent material **75m** to its non-fluent form. Alternatively, a major portion of the thermal treatment can be administered (that may be represented by the time “T1”) and then interrupted for a

brief period to insert the material **75m** and then completed at a different temperature level during time T2.

Other treatment temperature cycles and timing may also be used according to the ablation temperatures desired, depth of penetration desired, and stent material and composition and configuration employed as will be appreciated by those of skill in the art.

In certain embodiments, to allow for ease of retraction of the catheter after applying the thermal therapy and forming the stent **75**, as shown in **Figures 5B, 6A, 8 and 10A-10E**, a portion of the shaft **21b**, that portion that extends below the treatment balloon **15**, can be configured to have a diameter or width that is greater than the portion of the catheter shaft **21a** that is above the treatment balloon (the portion intermediate the treatment balloon **15** and the anchoring balloon **52**). The larger shaft **21b** can be sized so as to accommodate the dimension of the anchoring balloon **52** and treatment balloon **15** over its shaft (when deflated). As such, the increased size portion of the shaft **21b** may be about 5-25% larger than the (upper) reduced size portion **21a**.

As shown in **Figure 5A**, certain portions of the catheter **20** such as the bottom portion of the catheter **20b** that resides above the sphincter **13** can be configured to have radio-opaque indicia **77** (as denoted by the shaded region along the upper portion of the catheter. The indicia **77** can be any suitable radio-opaque feature such as a marker, surface, layer, or other feature so as to be imageable or visualized in an X-ray (to allow external positional verification of the device). **Figure 5A** illustrates that a series of radio-opaque markers may be employed, some axially extending and some radially extending to help confirm the positional location of the catheter when in the subject, irrespective of its orientation in the body. The stent material may also be configured to be externally detectable (such as with a radio-opaque dye or other additive/composition) so as to allow external positional verification by X-ray or other desired means. As such, X-rays can be taken at insertion/placement (initial positioning) and can also be taken periodically during to confirm proper positioning in the subject *in situ*.

As shown in **Figure 5A**, the radio-opaque markers **77** can be circumferentially arranged on the catheter either or both above **77u** and below **77l** (see also **Figure 1A**) the sealing balloon **22** so that the balloon **22** can be more

readily accentuated and confirmed in the X-ray as located in the membranous urethra, above the sphincter. Alternatively, or additionally, as shown in **Figure 5A**, one or more longitudinally extending radiopaque markers **77a** can be arranged to extend substantially along the length of the treatment balloon **15** at various radial positions (preferably at least 4 positions symmetrically separated and aligned about the cross-sectional width of the catheter, typically at 90 degree radial separation to allow for X-ray identification irrespective of the image angle). The radio-opaque markers are applied to block the transmission of X-ray for better contrast in images. The opacity, degree of contrast, and sharpness of the image may vary with material and type of process used to create the marker. The radio-opaque marker(s) may be arranged on the catheter by any suitable biocompatible marker, such as non-toxic radiopaque coatings, inks, thin-films, paints, tapes, strips, shrink tubing, and the like. *See e.g., Richard Sahagian, Critical Insight: Marking Devices with Radiopaque Coatings, Medical Device & Diagnostic Industry* (May, 1999), also available at URL deviceline.com/mddi/archive/99/05/011.html. Other examples of radiopaque markers include polyolefin inks available as No-Tox® Medical Device Polyolefin Inks from Colorcon, and resin compounds with barium sulfate and/or bismuth such as is available from New England Urethane Inc. of North Haven, CT. *See also Danilychev et al., Improving Adhesion Characteristics of Wire Insulation Surfaces, Wire Technology International, March 1994* (discussing various treatments such as gas plasma treatment systems for medical products) which may be appropriate for use in the fabrication of the catheter **20**.

As an alternative to (or in addition to) forming the medicaments into the stent **75**, medication, drugs, treatments, rinses, and the like can be introduced into the subject through an external medication port inlet and associated channel. The channel can be the urinary drainage channel **52d** or other of the elongated channels **21c** in the catheter or can be formed as its own separate channel and release port (not shown). The fluid (or mixture) can be directed to exit a desired port after the fluid travels through the catheter to the treatment site or proximate the treatment site. The medication inlet port can be provided with any suitable valve/port device as is known to those of skill in the art. Suitable valve devices (for both the inflation system and the medication delivery system) are available from medical

device manufacturers such as Alaris Medical Systems (SmartSite® system) and B. Braun. The medication can be used to reduce edema, inhibit bacterial infections, reduce the likelihood of UTI or treat the onset of UTI or otherwise promote healing and/or treatment.

5 As shown in **Figure 11**, the treatment balloon **15** may be provided in several lengths from about 3-12 cm, and typically from about 1-6 cm. The catheters **20** may be provided as a set with a range of lengths (such as in 0.5 cm increments) so as to allow a clinician to select from an easy compliment of assorted sizes and thus readily employ the size that fits the patient. Thus, the
10 catheters may be provided as a kit or set of catheters as shown in **Figure 11** with various lengths of treatment balloons **15** with the ports **80, 85** positioned at opposing ends of the treatment balloon (above and below) thereon.

The outer surface of the catheter **20** can be configured with a biocompatible lubricant or low-friction material to help reduce discomfort associated with the
15 insertion of the catheter device into the body as well as to promote the separation of the treatment balloon from the stent material **75m** in the body. Coatings that may be appropriate include coatings that promote lubricity, and wettability. For example, a hydrophilic coating which is applied as a thin (on the order of about 0.5-50 microns thick) layer which is chemically bonded with UV light over the
20 external surface of the stent **20**. One such product is a hydrophilic polymer identified as Hydrolene® available from SurModics, Inc., of Eden Prairie, MN. Other similar products are also available from the same source. Still further, the catheter **20** can be configured not only to provide the lubricious coating but to also include bioactive ingredients configured to provide sustained release of antibiotics,
25 antimicrobial, and anti- restenosis agents, identified as LubriLast™ from AST as noted above. One suitable material may be the antimicrobial silver zeolite based product available from HealthShield Technologies LLC of Wakefield, MA. Another alternative is a Photolink® Infection Resistance antimicrobial coating or a hemocompatible coating from SurModics, Inc. of Eden Prairie, MN. The coating
30 may also include other bioactive ingredients (with or without the antimicrobial coating), such as antibiotics, and the like. One product is identified as LubriLAST™ lubricious coatings from AST of Billerica, MA.

The flow channel **80c**, dispersing port **80**, and/or flushing channel and port **85c**, **85** can also be used to collect fluid specimens from the prostate region during the treatment (via gravity feed or suction and the like). Typically, the specimen is obtained prior to releasing the stent material into the prostatic urethra cavity.

5 These types of internal prostatic fluid specimens may be collected in a manner that is representative of its condition in the body (substantially void of urine and the like) to allow for a better specimen for analysis. See co-pending and co-assigned U.S. Provisional Patent Application Serial No. 60/330,029.

10 In addition, although the closed end configurations of the catheter **20** shown herein have been illustrated as substantially upright, they can also be curved into other configurations such as Coude or Tiemen.

15 Medicaments that may be incorporated into the stent **75** (such as in a slow release matrix formulation) and/or delivered separately include, but are not limited to, analgesics, anti-depressants, phytotherapy therapeutics such as PEENUTS or PROSTA-Q, anti-inflammatory agents such as steroid inhibitors (such as COX-2 inhibitors like VIOXX) and PENTOSAN POLYSULFATE, non-steroid inhibitors, antibiotics, neuroleptic agents (such as ELVAIL, NEURONTIN, DOXEPIN, and MARCAINE), α -blockers (such as PHENOXIBENZAMINE), specific immunology modulators such as ENBREL (by Immunex, a drug approved by the FDA for rheumatoid arthritis), bioflavonoids to reduce the level or oxidants in the prostatic fluid, FINASTERIDE, TERAZOSIN, ALFUZOSIN, antioxidants, quercitan, and the like, and combinations thereof.

20 **Figure 3** illustrates one embodiment of a thermal treatment system **100** that can be configured as a closed loop circulating fluid system. In particular 25 embodiments, the closed loop system **100** can be configured as a low-volume system to circulate between about 20-100 ml at any one time through the system (including the catheter **20** and the tubing **26t**). The system **100** includes a fluid circulation pump **160**, a pressure monitoring and controlling device **150**, a heater **140**, temperature sensors **106**, and a controller **120**. The system **100** can be 30 configured with a patient interface device **120u** to allow a patient to adjust the treatment pressure. The arrows in the figure illustrate the direction of the circulating fluid flow in the system and catheter.

In certain embodiments, as discussed above, the stent material flow channel 80c can also be used to obtain a prostatic fluid specimen from the prostate. Thus, the syringe 96 may be replaced with a pump or length of conduit that connects to the existing circulation pump 160 to draw or direct the fluid therein to discharge
5 downstream of the pump 160 into a biosample collection chamber or container to provide the suction force to obtain the prostatic fluid biosample. In other embodiments, gravity, capillary action, or other collecting means may be employed. *See e.g.*, U.S. Patent Application 09/433,952 and U.S. Patent 5,549,559, the contents of which are hereby incorporated by reference as if recited
10 in full herein, for descriptions of a suitable closed loop circulating fluid system. Fluid circulating WIT catheters with expandable treatment balloons are available from ArgoMed, Inc., in Cary, NC. The pressure in the treatment balloon (which corresponds to the pressure in the closed loop system) may be from about 0.5-4 atm, and typically at least about 0.75-2 atm during at least a portion of the
15 treatment to increase the force (that may be pulsatile) presented to the localized tissue.

In certain embodiments, the circulation can be provided by using a peristaltic pump to generate pulsatile fluid flow. A three-roller pump may be configured to operate to provide about 1-12 or 1-20 expansion and contraction
20 pulses per second to about 1-12 or 1-20 pulses per minute in the balloon. In particular embodiments, this action can be caused by using a pulsatile flow pump having three rollers with between about 200-750 rotations per minute while a two roller pump may be configured to operate with between about 200-500 rotations per minute; each can operate so as to provide a corresponding number of pulses to
25 the treatment balloon. Suitable pump heads are available from Watson Marlow Inc., of Wilmington, MA, and Barnant Co., of Barrington, IL. Of course, other methods for expanding and contracting a treatment balloon or generating the pulsatile flow can also be used as will be appreciated by those of skill in the art.

Turning now to **Figure 4**, operations for a method for treating the prostate and inhibiting the obstruction of the prostatic urethra after thermal ablation (or
30 resection or other inflammatory procedure) according to the present invention, is shown. First, a treatment catheter is positioned in the subject so that a treatment balloon resides proximate the prostatic tissue (**block 200**) and administers a

thermal ablation treatment (**block 205**). Flowable stent material that is selectively transformable from fluent to non-fluent states is released from the thermal ablation treatment catheter in a fluent state to reside about the prostatic urethra (**block 210**). The flowable stent material can be a viscous or semi-viscous material in the fluent state. The fluent stent material can be formed or pressed against the prostatic urethra wall or inner surface by expanding the treatment balloon (**block 220**). The stent material is activated *in situ* to cure or become non-fluent and form the stent in the body (**block 230**). The stent material can be activated via heat (**block 222**), cooling (**block 223**), exposure to light (ultraviolet, etc) (**block 224**), or by chemical reaction (**block 225**). The treatment catheter is removed from the subject leaving the stent in the treatment region (**block 240**).

The flowable stent material can be introduced before, after, or during the administration of the thermal ablation therapy and then activated *in situ* to form a resilient biodegradable biocompatible stent that inhibits obstruction of the urethra during post-treatment healing (**block 212**). In certain embodiments, the flowable stent material can be configured to be applied via a non-fluent coating or layer applied to the outer surface of the treatment balloon that becomes fluent in the body when heated and then transforms back to its non-fluent state upon cooling to remain (**block 214a**). The stent material can be held in the catheter in a fluent state and dispersed from the treatment catheter in a fluent state (**block 214b**).

For particular embodiments of treating BPH, the catheter can be configured to circulate heated liquid in a closed loop system through the prostate. The circulating heated liquid is directed through the catheter to a treatment balloon such that it travels, captured in the catheter, through the penile meatus, along the penile urethra the bulbous urethra, and the membranous urethra to a localized treatment region in the prostate inside the treatment balloon. The tissue in the localized treatment region in the prostate is exposed to a temperature above about 45°C for a predetermined thermal ablation treatment period by exposure to contact with the expanded balloon that contains the heated circulating liquid (typically at about 50-62°C for more than about 20-60 minutes). As noted above, the localized treatment region can be an upper portion of the urethra (typically called the prostatic urethra), leaving the lower part of the urethra (the membranous urethra), non-ablated. As such, the liquid does not directly contact the tissue. This can be

accomplished in closed loop circulating systems, which heat the liquid remotely, by insulating the shaft of the treatment catheter up to the treatment balloon to inhibit the exposure of non-targeted tissue to ablation temperatures.

In other embodiments, the circulating fluid can be heated to lower
5 treatment temperatures, such as between 45-50°C, or even less than 45°C (such as 35°C-44°C) to provide cooling at the localized tissue region and/or the stent material, as desired.

It will be understood that one or more blocks of the block diagrams and combinations of blocks in block diagram figures can be implemented or directed to
10 be carried out by computer program instructions. These computer program instructions may be loaded onto a computer or other programmable data processing apparatus to produce a machine, such that the instructions which execute on the computer or other programmable data processing apparatus create means for implementing the functions specified in the flowchart block or blocks. These
15 computer program instructions may also be stored in a computer-readable memory that can direct a computer or other programmable data processing apparatus or associated hardware equipment to function in a particular manner diagrams. The operations or the blocks in the diagrams may be combined, separated, or carried out in a different order from that shown.

Figures 10A-10E illustrate operative configurations of an exemplary
20 treatment catheter **20** according to embodiments of the present invention. **Figure 10A** illustrates the treatment catheter **20** in position and administering a thermal therapy (such as a thermal ablation therapy) to the subject (the heat dispersion is shown by the lines with arrows in the prostate in the figure). During the thermal
25 ablation therapy, the sealing balloon **22** can be deflated. **Figure 10B** illustrates the release of fluent stent material **75m** from the catheter and its movement upward away from the dispersing port(s) **80** to the flushing port(s) **85**. The sealing balloon **22** is inflated to contact and substantially seal against the membranous urethra to contain the material above the sphincter **13**. As shown, the treatment balloon **15**
30 may be partially or wholly deflated during this operation to allow the stent material to flow upwardly with less restriction. In particular embodiments, the stent material **75m** can be introduced in sufficient quantity to substantially fill the prostatic cavity between the balloons **52** and **22** and the treatment balloon **15**.

Figure 10C illustrates an alternative configuration, whereby stent material **75m** (shown by the dark lines with arrows) is released from dispersing ports located both above and below the treatment balloon **15** (that may be partially or wholly deflated).

5 As is also shown in **Figure 10D**, the sealing balloon **22** can be configured to expand a greater distance than the treatment balloon **15** (indicated by the width, "LW"). In any event, **Figure 10D** shows that the treatment balloon **15** can be expanded to press and/or form the fluent stent material **75m** to the walls of the prostatic urethra and to apply heat to activate or transform the stent material so as
10 to make it non-fluent. **Figure 10E** illustrates that to remove the catheter **20**, all balloons **52, 25, 22**, are deflated, and the stent **75** remains in position and inhibits the closure of the prostatic urethra during post-treatment inflammation (shown by the converging arrows directed at the urethra passage). It is noted that configuring the portion of the shaft **21b** in the membranous urethra below the treatment
15 balloon with an increased width and/or diameter that reduces the interference of the stent **75** with the smaller sized upper portion of the shaft **21a** and can inhibit the disruption and/or dislocation of the stent upon removal of the catheter.

Figure 10D may also be referenced to illustrate another embodiment where the stent material **75m** can be released from the treatment balloon **15** to radially
20 disperse about the length of the treatment balloon **15**. The stent material **75m** can be released through a porous or permeable sleeve **15s**. Alternatively, the stent material **75m** can be configured as a nonfluent outer layer **75l** formed over the treatment balloon **15** (**Figure 1A**) as discussed above. **Figure 10D** also illustrates the treatment balloon **15** can be expanded during this release as desired.

25 The biocompatible biodegradable stents of the present invention can fuse with the urethral tissue. This bio-attachment can decrease the potential that the stent will dislocate from its intended location during the healing period and may be particularly suitable for treating conditions of the prostate having increased internal pressures such as inflammation of the prostate (such as is associated with post-
30 ablation procedures and the like) and/or hyperplasia.

The methods and catheters of the present invention may be used for other applications, such as to treat and/or form biodegradable stents and the like for other natural lumens or body cavities that have periodic fluid or solid movement of

biomaterials therethrough, such as the rectum, the colon, the cervix and/or uterus, the bladder, the throat, the ear, the nose, passages of the heart and/or associated valves, portions of the respiratory system, the esophagus, the stomach, bile ducts, and the like.

5 The foregoing is illustrative of the present invention and is not to be construed as limiting thereof. Although a few exemplary embodiments of this invention have been described, those skilled in the art will readily appreciate that many modifications are possible in the exemplary embodiments without materially departing from the novel teachings and advantages of this invention. Accordingly,
10 all such modifications are intended to be included within the scope of this invention as defined in the claims. Therefore, it is to be understood that the foregoing is illustrative of the present invention and is not to be construed as limited to the specific embodiments disclosed, and that modifications to the disclosed embodiments, as well as other embodiments, are intended to be included
15 within the scope of the appended claims. The invention is defined by the following claims, with equivalents of the claims to be included therein.

THAT WHICH IS CLAIMED IS:

1. A method of treating a condition of the prostate and forming a prostatic stent *in situ* in the prostatic urethra, comprising:
 - introducing a catheter having an expandable treatment balloon thereon into the male urethra of the subject so that the treatment balloon resides proximate the prostatic urethra;
 - administering a thermal ablation therapy to the prostatic urethra of the subject via the treatment catheter, wherein the thermal ablation therapy has a duration of at least about 10 minutes;
 - releasing biocompatible biodegradable fluent stent material from the catheter;
 - activating the stent material *in situ* to cause it to attach to the interior surface of the prostatic urethra so as to take on a non-fluent form to define a stent having sufficient thickness to inhibit closure of the prostatic urethra after administration of the thermal therapy; and
 - then removing the treatment catheter such that the stent remains in position in the prostatic urethra.
2. A method according to Claim 1, wherein the step of releasing is carried out after initiation of or during the administering step to direct fluent stent material to travel into the acini ducts during the administering step.
3. A method according to Claim 1, wherein the step of administering the thermal ablation therapy comprises administering a thermal ablation therapy at a temperature of between about 57-80°C for at least a portion of the treatment session, and wherein the step of releasing is carried out before the administering step to thereby direct fluent stent material to flow into the acini ducts during the administering step.

4. A method according to Claim 1, wherein the step of releasing is carried out after, but proximate in time to, the administering step.
5. A method according to Claim 1, wherein the thermal ablation therapy is carried out for at least about 20-60 minutes, and wherein, after removal of the catheter, the stent has a thickness of at least about 1-2 mm average about the circumference of the prostatic urethra.
6. A method according to Claim 1, wherein the stent material is a good heat conductor, and wherein the flowable stent material is configured to be imageable by X-ray to verify the location of the stent *in vivo*.
7. A method according to Claim 1, wherein the treatment catheter has a bladder anchoring balloon disposed above the treatment balloon and an axially extending shaft, said method further comprising:
inflating the bladder anchoring balloon to attach to the bladder neck of the subject prior to the administering step; and
deflating the bladder anchoring balloon prior to the removing step.
8. A method according to Claim 2, wherein the administering step comprises expanding the treatment balloon, and the method further comprises:
partially or wholly deflating the treatment balloon during the releasing step
pressing the fluent stent material into intimate contact with the interior surface of the prostatic urethra with the expandable treatment balloon; and
pressing the fluent stent material into intimate contact with the interior surface of the prostatic urethra with the expandable treatment balloon.
9. A method according to Claim 1, wherein the releasing step comprises directing liquid stent material to flow from a supply located external of the body of the subject through the catheter so that it exits the catheter proximate the prostatic urethra in sufficient quantity, and wherein the method further comprises pressing the fluent stent material into intimate contact with the interior surface of the prostatic urethra with the expandable treatment balloon.

10. A method according to Claim 9, wherein said catheter comprises a third expandable sealing balloon located below the treatment balloon so that in the body of the subject it resides above the urinary sphincter, and wherein the method further comprises expanding the third balloon so that it contacts the membranous urethra during the releasing and activating steps thereby inhibiting the stent material from traveling below the third sealing balloon in the body.

11. A method according to Claim 10, wherein the releasing step comprises directing two liquid materials held in fluid isolation in the catheter to exit the catheter separately and mix *in situ* to form the stent.

12. A method according to Claim 10, wherein the releasing step comprises directing the flowable stent material to travel under pressure through the catheter, exit the catheter in at least one dispersing port located below the treatment balloon so that it travels upward in the body to reenter the catheter via at least one flushing port located above the treatment balloon, and exit the body of the subject via the catheter, thereby allowing a clinician to verify that a sufficient quantity of the stent material has been administered over the prostatic urethra.

13. A method according to Claim 12, wherein the dispersing port is configured and sized to be larger than the flushing port.

14. A method according to Claim 12, wherein the administering step comprises circulating heated fluid in the treatment catheter to expand the treatment balloon with heated fluid so that the expanded balloon contacts the stent material and presses it against the interior surface of the prostatic urethra.

15. A method according to Claim 1, wherein the releasing step comprises:

forming a solidified stent material layer onto the outer surface of the treatment balloon; and

applying a first thermal treatment to the solidified material via the treatment balloon to transform the solidified material layer into a flowable viscous form that flowably releases the stent material from the catheter,

and wherein the method further comprises pressing the fluent stent material into intimate contact with the interior surface of the prostatic urethra with the expandable treatment balloon.

16. A method according to Claim 15, wherein the activating step
5 comprises applying a second thermal treatment to cause the flowable stent material to resolidify.

17. A method according to Claim 16, wherein the first thermal
10 treatment has a greater temperature than the second thermal treatment.

18. A method according to Claim 16, wherein the second thermal
treatment has a greater temperature than the first thermal treatment.

19. A method according to Claim 16, wherein the administering step
15 comprises circulating heated fluid in the treatment catheter to expand the treatment balloon with heated fluid so that the expanded balloon contacts the stent material and presses it against the interior surface of the prostatic urethra.

20. A method according to Claim 1, wherein the catheter comprises an
20 expandable permeable sleeve in fluid communication with a liquid material flow port, the sleeve overlying the treatment balloon so that it is concurrently inflatable via inflation of the underlying treatment balloon and configured so as to be separately inflatable from the underlying treatment balloon, wherein the releasing step comprises directing stent material to flow through the catheter, out of the
25 liquid material flow port, and out of the permeable sleeve into the prostatic urethra.

21. A method according to Claim 20, wherein the step of directing in
the releasing step is carried out while the underlying treatment balloon is wholly or
partially deflated.

30

22. A method according to Claim 21, wherein the step of directing is
carried out while the underlying treatment balloon is inflated.

23. A method according to Claim 20, further comprising pressing the fluent stent material against the internal surface of the prostatic urethra cavity, wherein the treatment balloon is expanded during the administering step, deflated wholly or partially during the releasing step and then expanded again during the activating and pressing steps.

24. A method according to Claim 1, wherein the catheter has an elongated, axially extending shaft configured so that an upper portion located above the treatment balloon has a reduced cross-sectional size relative to the portion below the treatment balloon.

25. A method according to Claim 1, wherein the activating step is carried out by applying heat at or above a predetermined temperature.

26. A method according to Claim 1, wherein the activating step is carried out by exposing the stent material to light.

27. A method according to Claim 1, wherein the step of releasing fluent stent material is carried out by separately introducing two flowable substances from the catheter, and wherein the step of activating is carried out by mixing the two substances *in situ* to cause a chemical reaction.

28. A method of treating BPH, comprising:
thermally ablating localized tissue in the prostate with a treatment catheter having an expandable treatment balloon thereon;
directing fluent viscous or semi-viscous biocompatible biodegradable stent material from the treatment catheter into the prostate;
expanding the treatment balloon to press the stent material away from the treatment balloon toward the interior surface of the prostatic urethra;
securing the stent material to the prostatic urethra so that it defines a resilient conformable stent that remains in position after removal of the treatment catheter to inhibit the closure of the urinary passage; and
removing the treatment catheter from the body of the subject.

29. A method according to Claim 28, wherein the directing step is carried out before the thermal ablating step.

30. A method according to Claim 29, wherein the directing step is carried out after the thermal ablating step has been commenced.

31. A method according to Claim 28, wherein the directing step is performed after the thermal ablating step is substantially complete.

32. A method according to Claim 28, wherein the stent material is directed to enter into a plurality of the acini ducts, wherein the thermal ablating step is carried out for at least about 20-60 minutes, and wherein the resilient stent has a thickness sufficient to maintain a desired urinary flow during the post-treatment healing process.

33. A method according to Claim 28, wherein the thermal ablating step comprises:

circulating liquid via a closed loop system where the liquid is heated external of the body of the subject and circulated into the subject in the treatment catheter to a localized treatment region in the prostate for between about 40-60 minutes; and

exposing targeted tissue in the prostate in a localized treatment region to heat at a desired temperature for a predetermined thermal treatment period corresponding to the circulating heated liquid.

34. A method according to Claim 33, wherein heat provided by the circulating heated liquid causes the flowable material to become non-fluent and adhere to the interior surface of the prostatic urethra.

35. A method according to Claim 34, wherein the flowable stent material comprises a biocompatible and/or biodegradable polymeric matrix.

36. A catheter for treating a condition of the prostate, comprising: an elongated axially extending shaft;

a treatment balloon secured to the shaft and configured to expand outwardly therefrom, the treatment balloon configured to apply a thermal therapy to targeted tissue in the body;

5 a bladder-anchoring balloon secured to the shaft above the treatment balloon and configured to expand outwardly from the shaft;

a sealing balloon secured to the shaft below the treatment balloon and configured to expand outwardly from the shaft;

a urinary drainage channel extending through the shaft; and

10 a flowable biocompatible biodegradable stent material channel having at least one ejection port formed in the shaft associated therewith, the flowable material channel being in fluid isolation with the drainage channel;

wherein the shaft is configured and sized such that the portion intermediate the treatment balloon and anchoring balloon has a decreased cross-sectional width relative to a portion of the shaft intermediate the treatment balloon and sealing
15 balloon, and wherein, in operation, the sealing balloon and the bladder anchoring balloon are in an expanded configuration when flowable biocompatible biodegradable stent material is directed to exit the ejection port.

37. A catheter according to Claim 36, further comprising a flushing port
20 and associated flushing channel disposed in the shaft above the at least one ejection port, wherein, in operation, the flushing port is configured to receive flowable stent material therein and direct it to flow out of the body of the subject in the flushing channel that is in fluid isolation from the flowable stent material ejection channel to thereby allow a clinician to verify that the flowable stent material has traveled
25 about the prostatic urethra.

38. A catheter according to Claim 37, wherein the flushing port is smaller than the at least one ejection port.

30 39. A catheter according to Claim 36, further comprising inlet and outlet circulating liquid channels in fluid communication with the treatment balloon, wherein the treatment balloon expands responsive to the amount of liquid circulating therethrough.

40. A catheter for treating a condition of the prostate, comprising:
an elongated axially extending shaft;
a treatment balloon secured to the shaft and configured to expand
outwardly therefrom;
5 a bladder-anchoring balloon secured to the shaft above the treatment
balloon and configured to expand outwardly from the shaft;
a urinary drainage channel extending through the shaft; and
a non-fluent transformable biocompatible biodegradable stent material
layer formed over the outer surface of the treatment balloon, the stent material
10 being selected such that, when exposed to predetermined temperatures, the stent
material becomes fluent and is released from the treatment balloon to flow to
surrounding regions in the prostatic urethra and then, upon exposure to at least one
of different predetermined temperatures, light, or chemical activation, becomes
non-fluent and remains in intimate contact with the interior surface of the prostatic
15 urethra to define a biocompatible biodegradable stent.

41. A catheter according to Claim 40, wherein the shaft is configured
and sized such that a portion intermediate the treatment balloon and anchoring
balloon has a decreased cross-sectional width relative to the portion of the shaft
20 immediately below the treatment balloon.

42. A catheter for treating a condition of the prostate, comprising:
an elongated axially extending shaft;
a treatment balloon secured to the shaft and configured to expand
25 outwardly therefrom;
an outwardly expandable permeable or porous sleeve configured to overlie
the treatment balloon, the sleeve being independently inflatable from the treatment
balloon;
a quantity of flowable biocompatible biodegradable stent material disposed
30 intermediate the treatment balloon and the sleeve;
a bladder-anchoring balloon secured to the shaft above the treatment
balloon and configured to expand outwardly from the shaft;
a sealing balloon secured to the shaft below the treatment balloon and
configured to expand outwardly from the shaft;

a urinary drainage channel extending through the shaft; and
a flowable fluent biocompatible stent material channel having at least one
ejection port formed in the shaft in fluid communication with the sleeve so as to
direct the flowable biocompatible stent material therein, the flowable material
5 channel being in fluid isolation with the drainage channel;

wherein, in operation, the treatment balloon is adapted to inflate to press
the flowable stent material released from the sleeve into the targeted tissue in the
body.

10 43. A catheter according to Claim 42, wherein the shaft is configured
and sized such that the portion intermediate the treatment balloon and anchoring
balloon has a decreased cross-sectional width relative to the portion of the shaft
intermediate the treatment balloon and sealing balloon.

15 44. A biodegradable stent for the prostatic urethra defined by a
selectively transformable non-fluent biocompatible biodegradable polymeric
material in intimate contact with tissue on the surface of the prostatic urethra and
configured to extend a distance into a plurality of the acini ducts, the biodegradable
stent being resilient and having a sufficient thickness and length to inhibit closure
20 of the urinary flow passage through the prostatic urethra associated with increased
inwardly directed pressures associated with inflammation of the prostate or
hyperplasia.

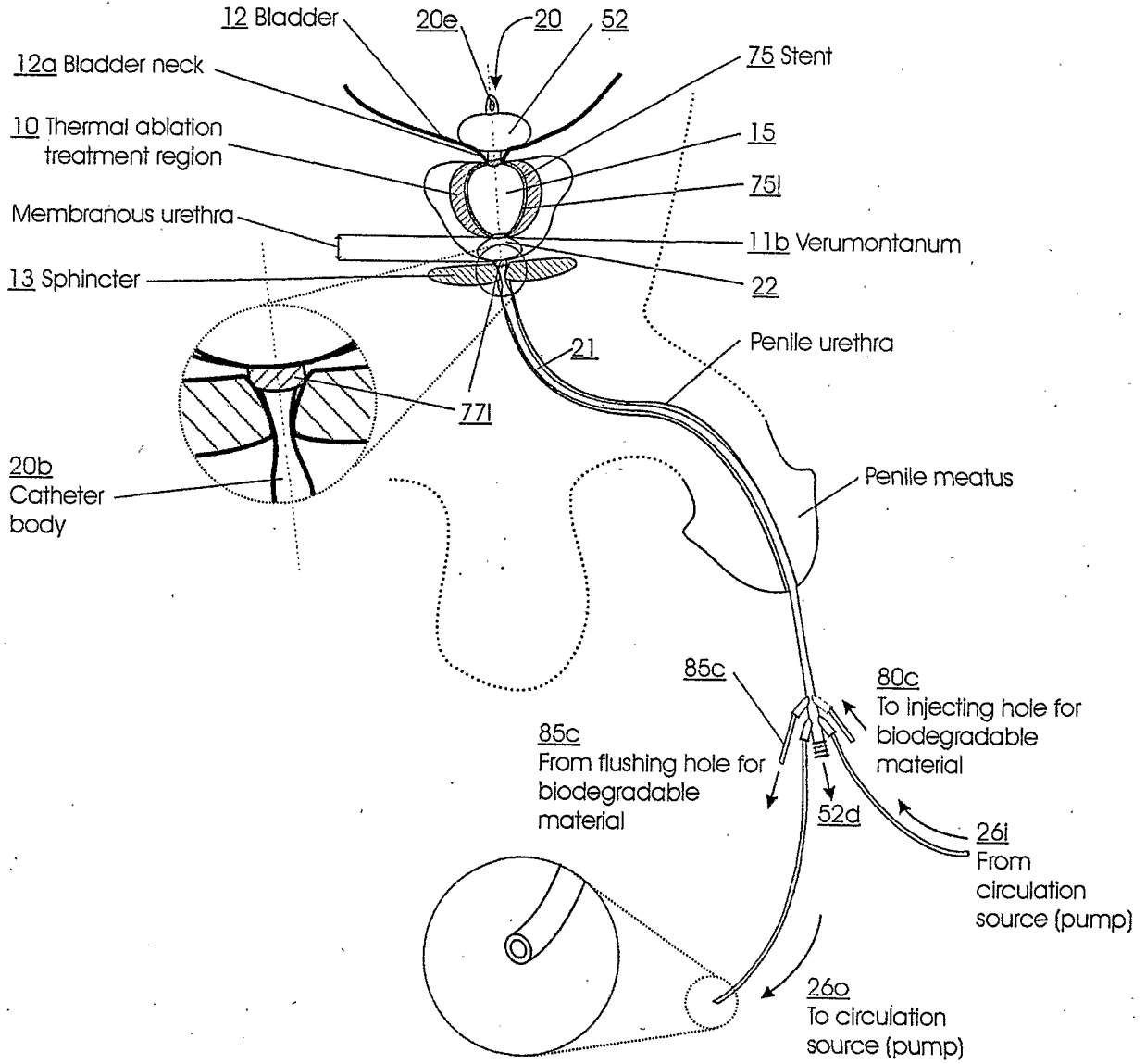
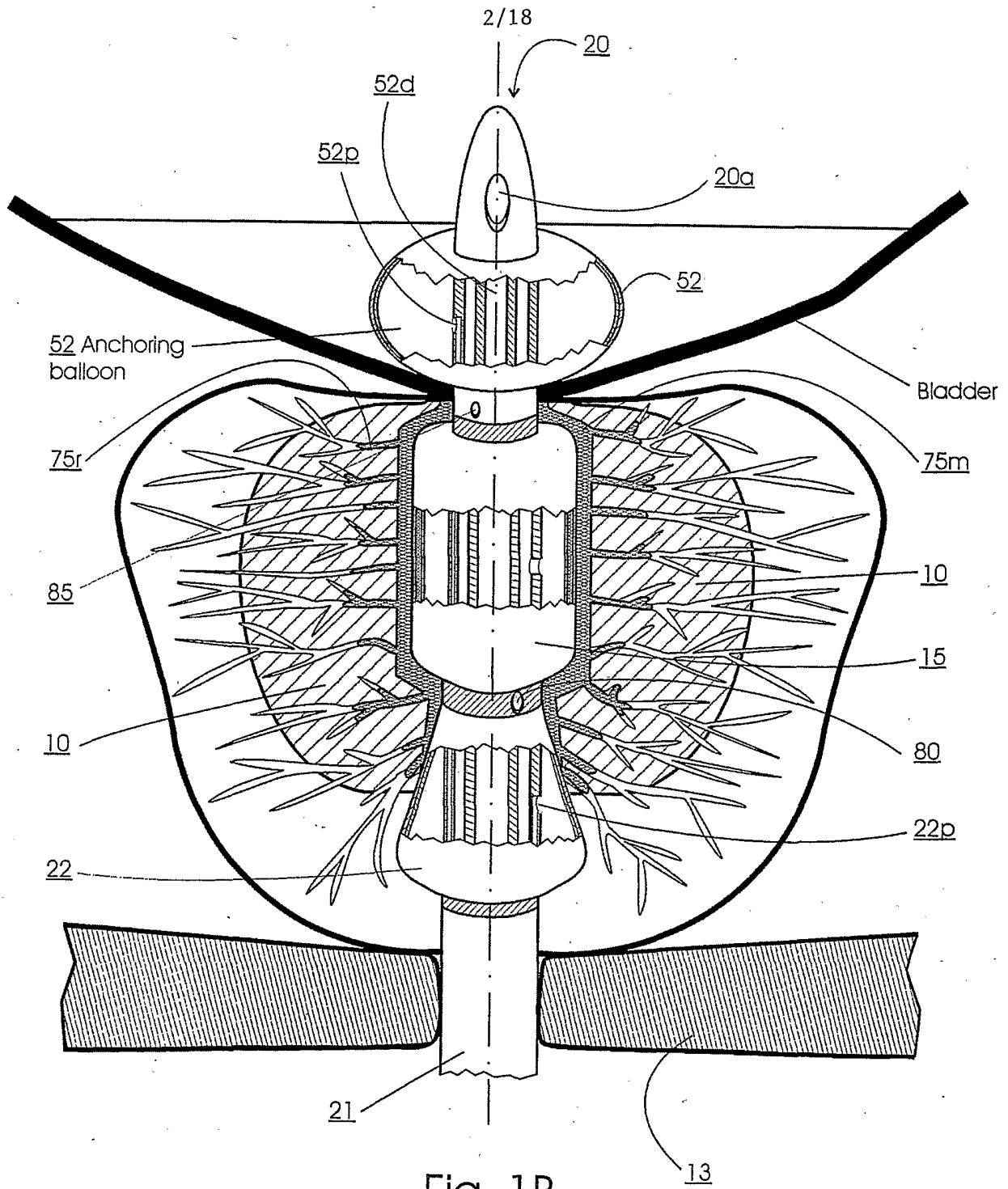

Fig. 1A



3/18

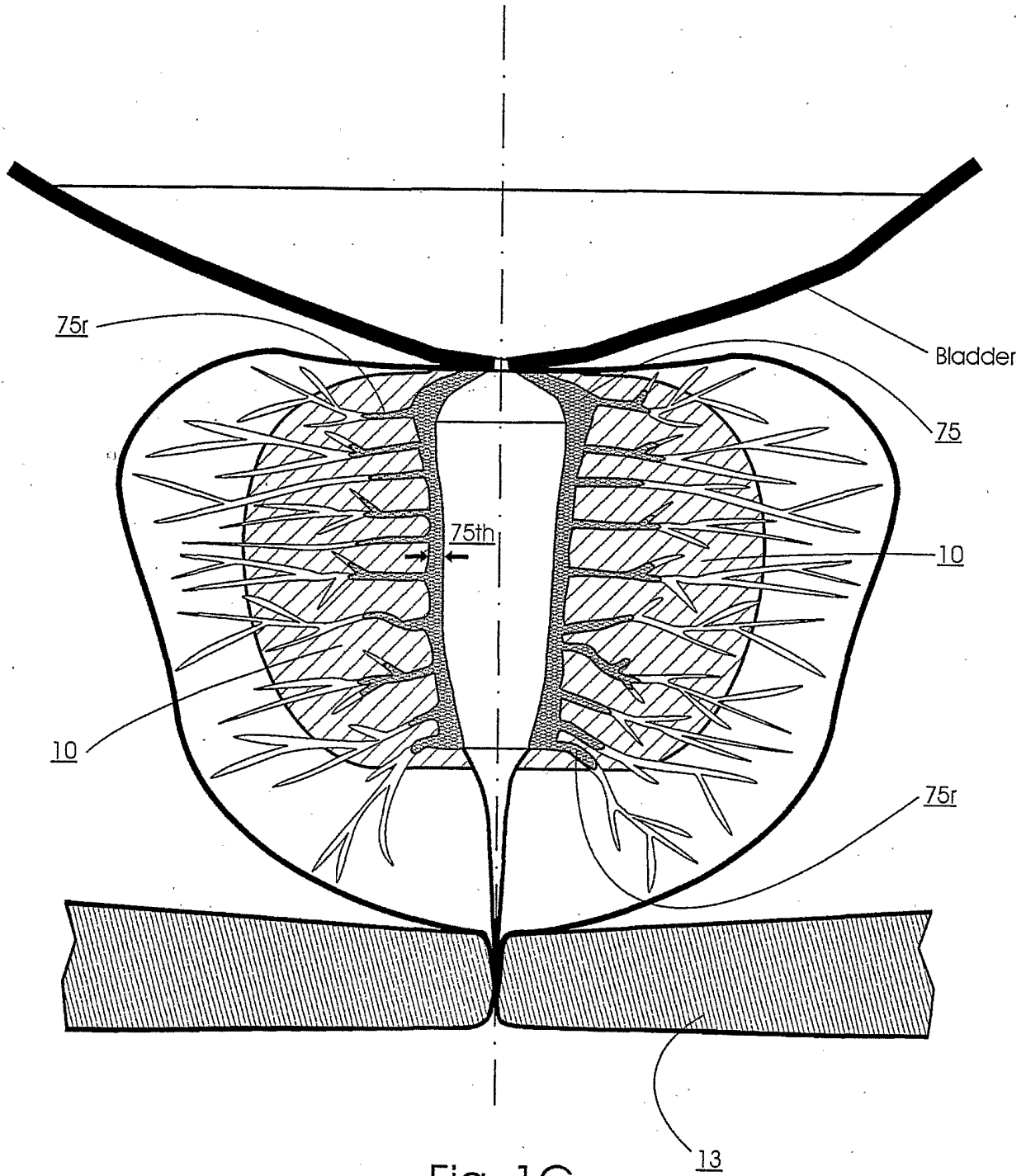

Fig. 1C

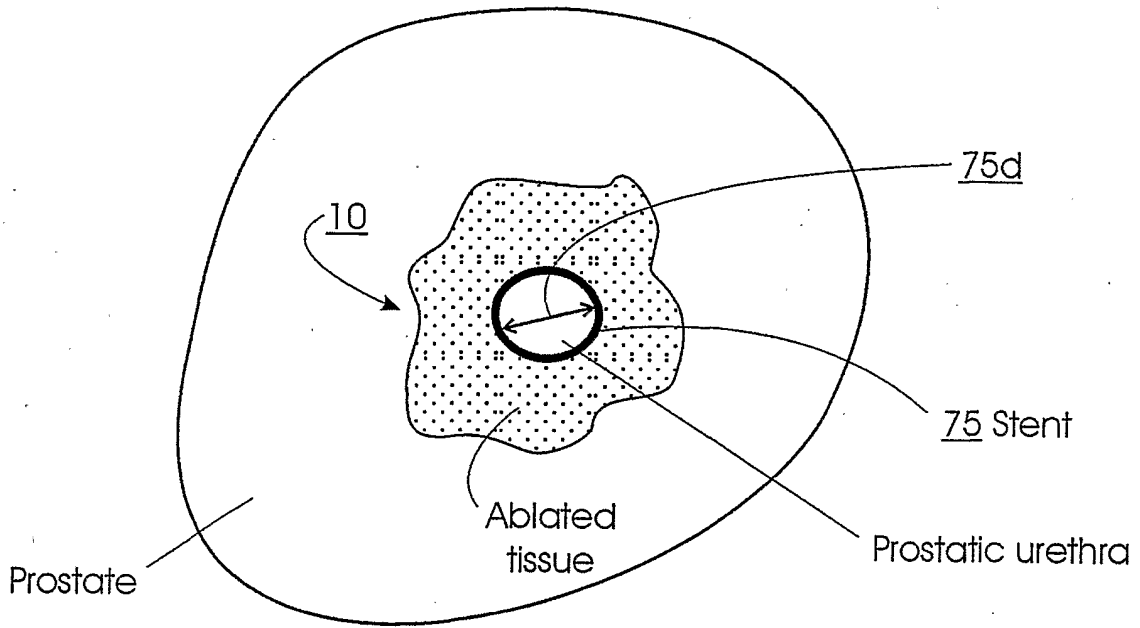

Fig. 2A

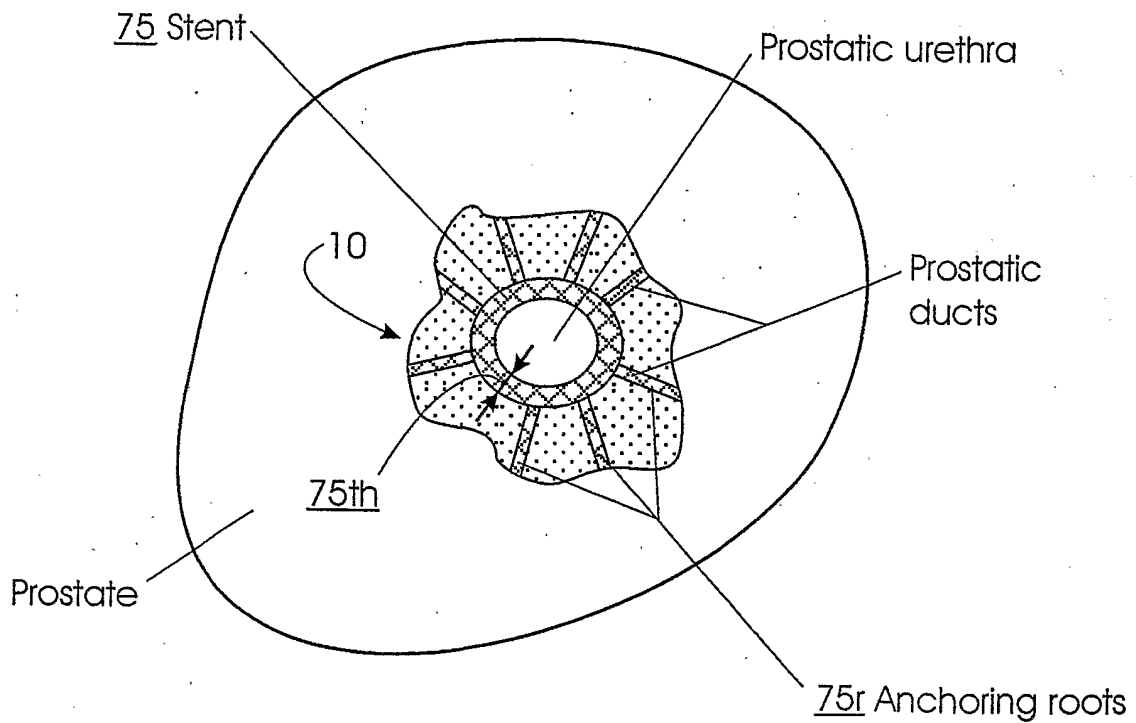

Fig. 2B

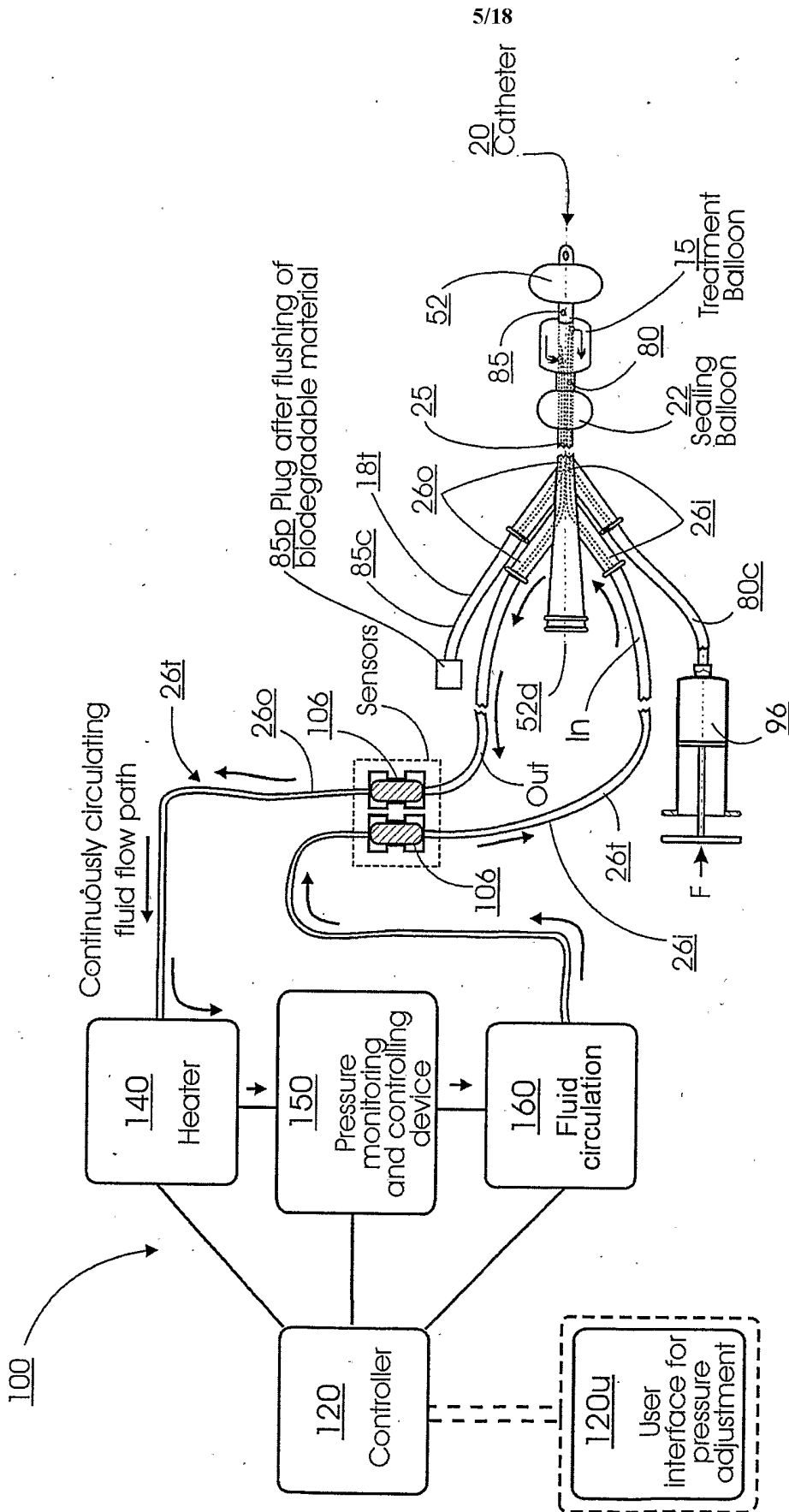

Fig. 3

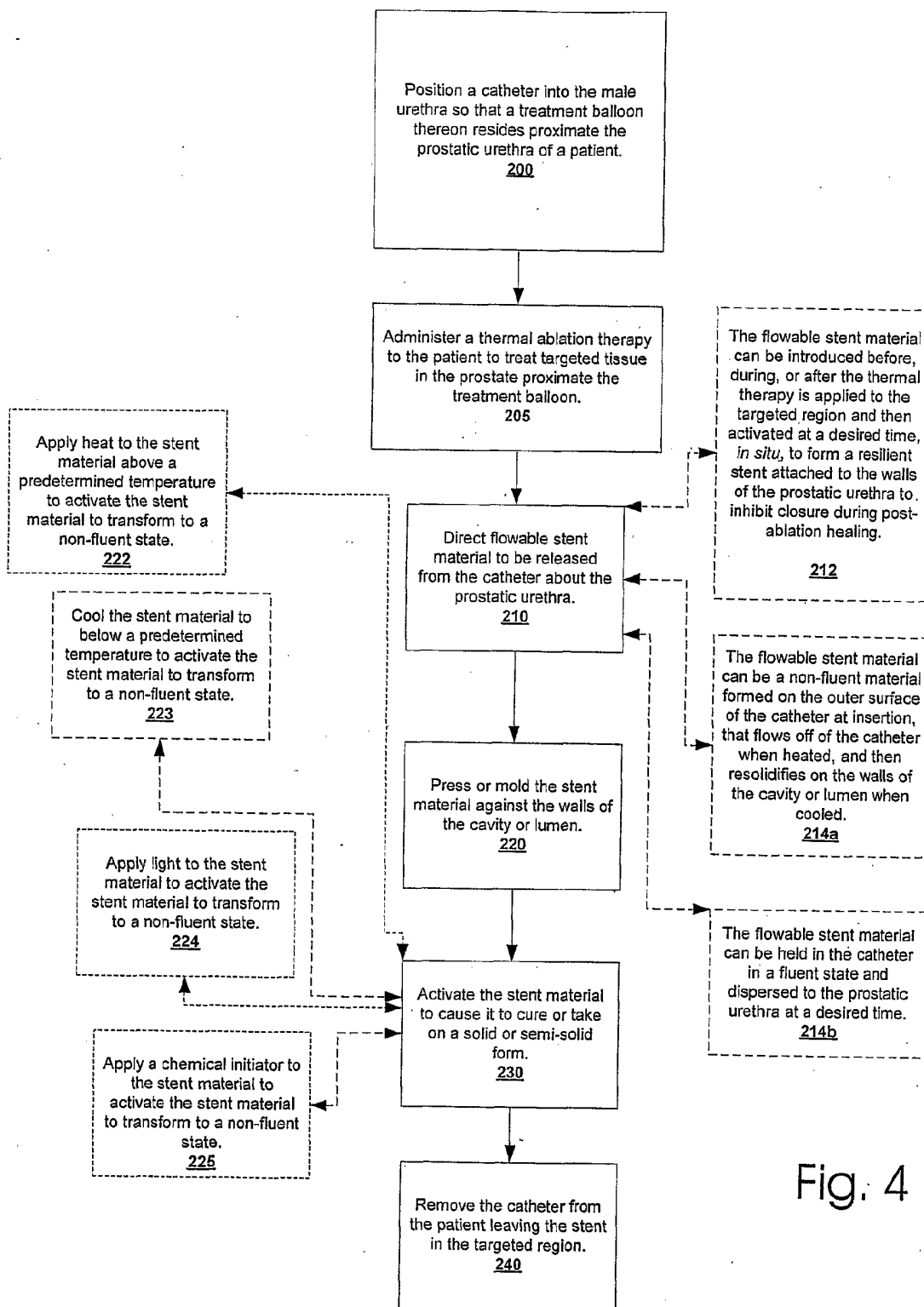

Fig. 4

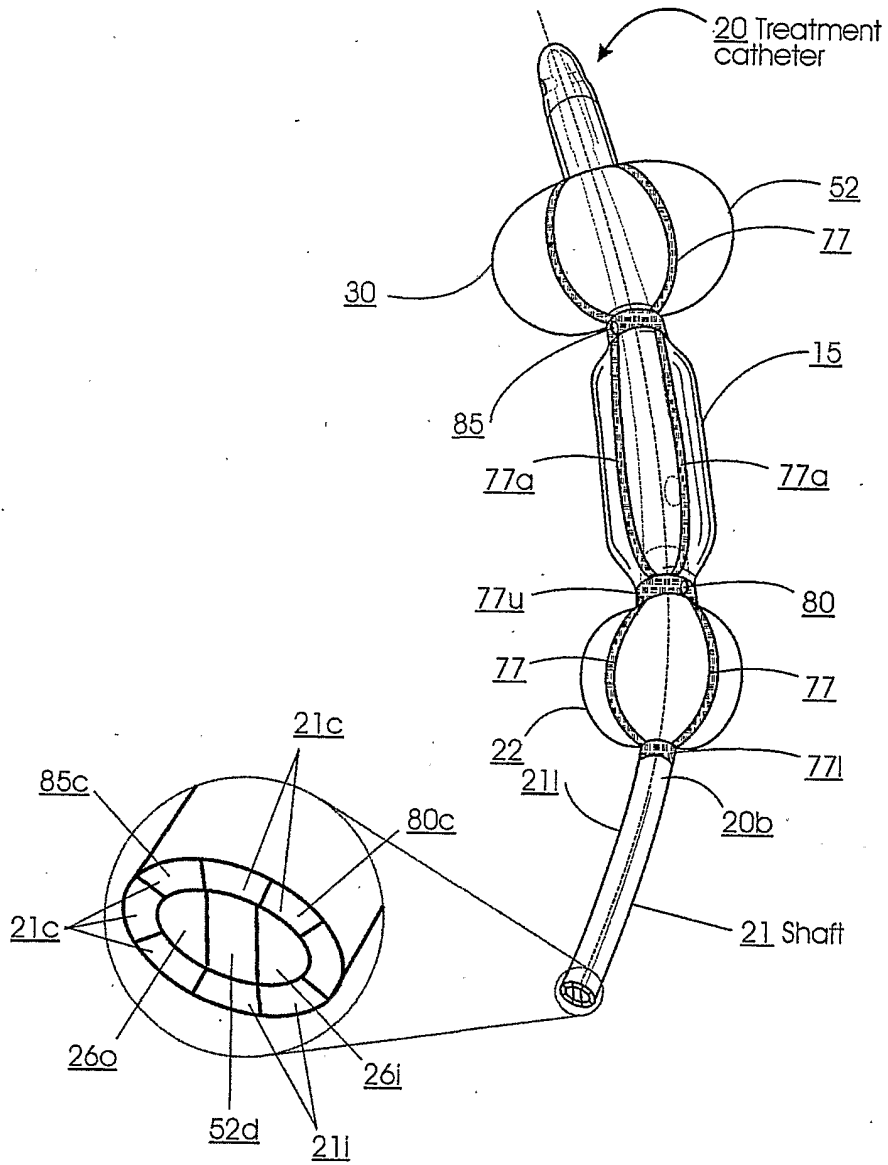

Fig. 5A

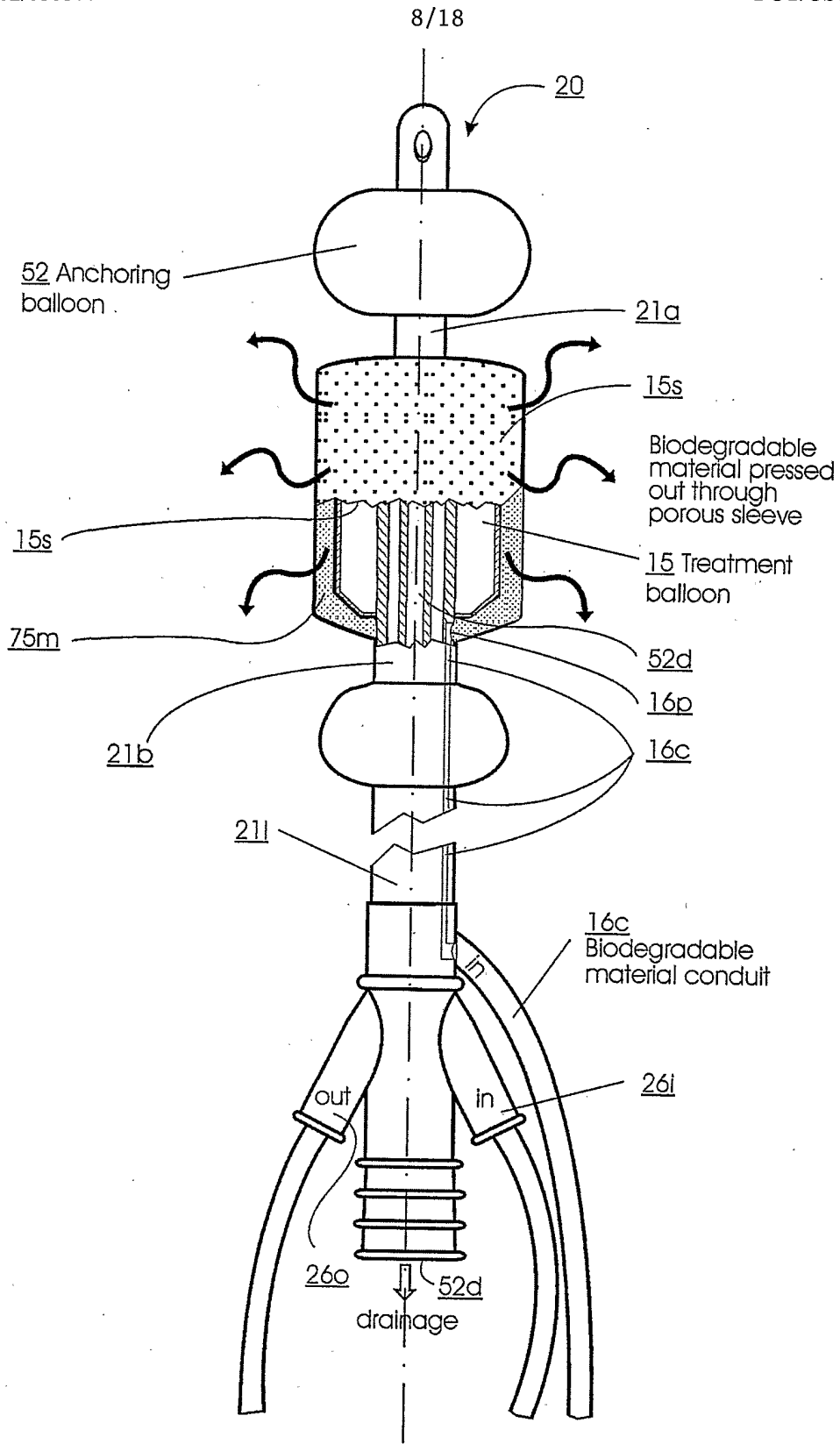

Fig. 5B

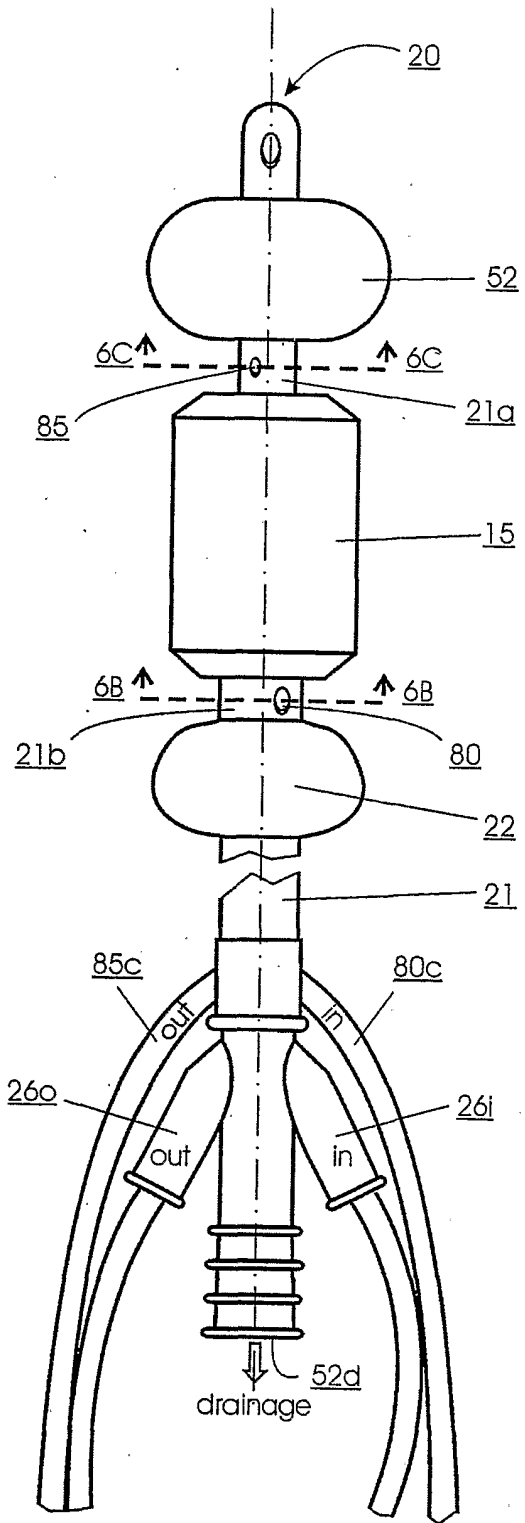

Fig. 6A

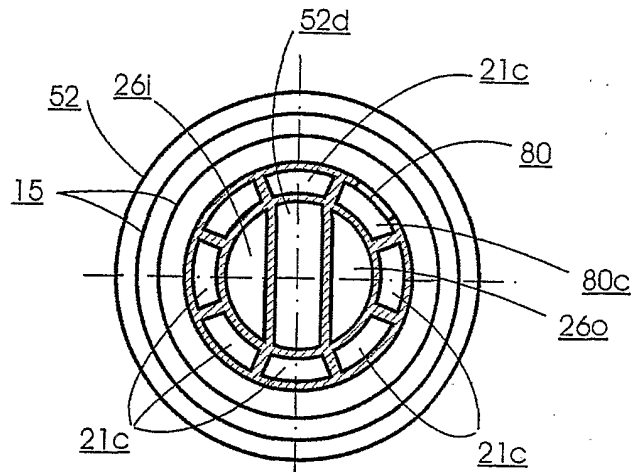

Fig. 6B

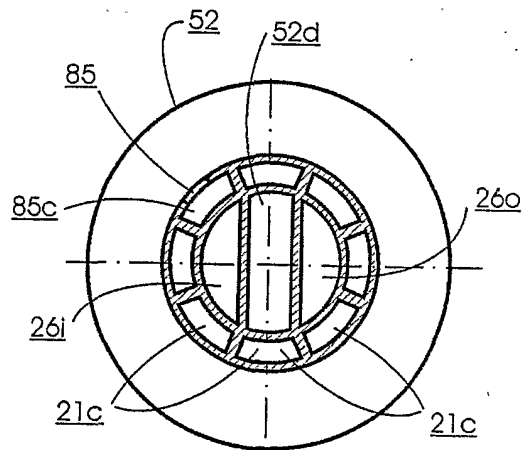

Fig. 6C

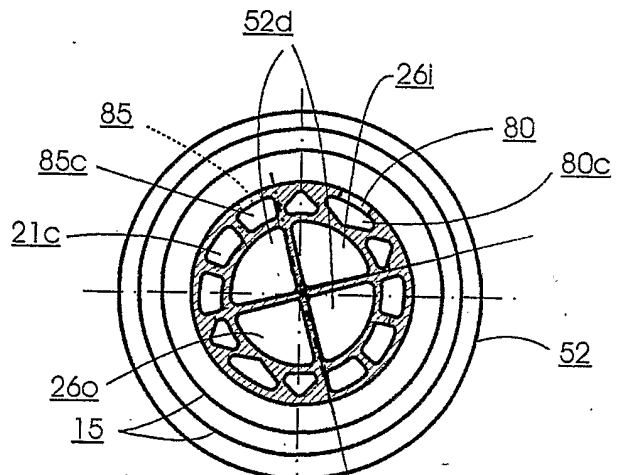

Fig. 6D

10/18

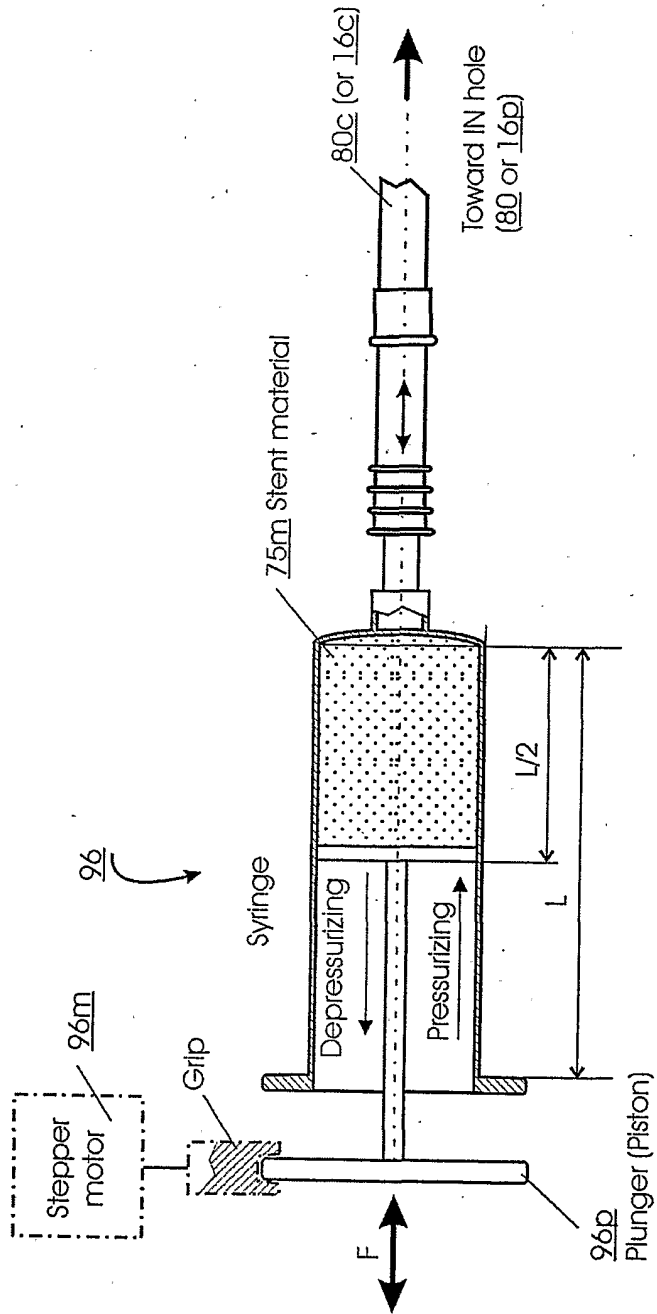

Fig. 7

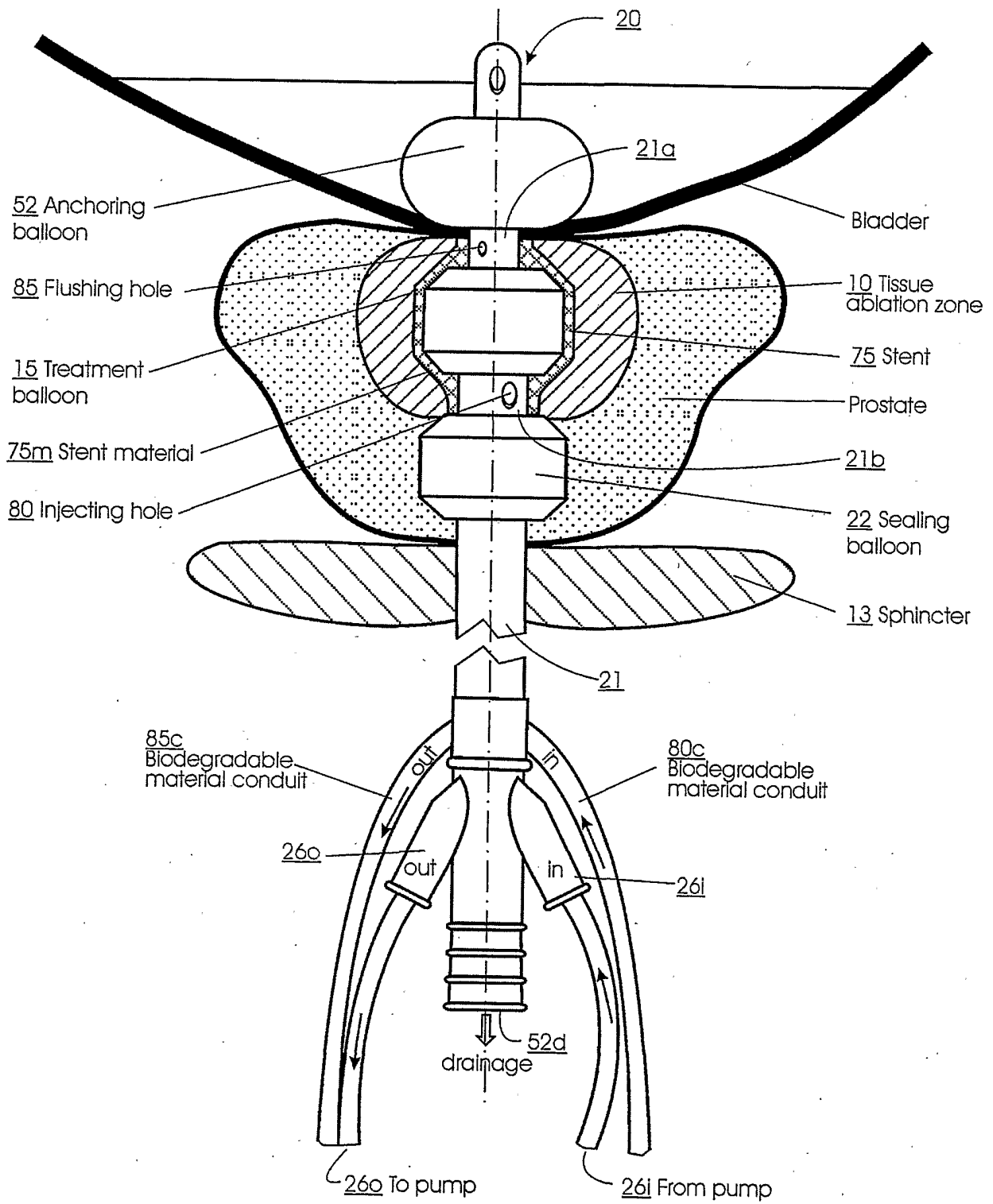

Fig. 8

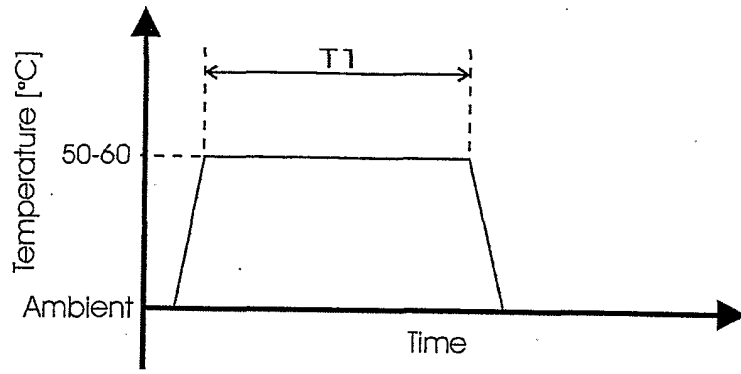

Fig. 9A

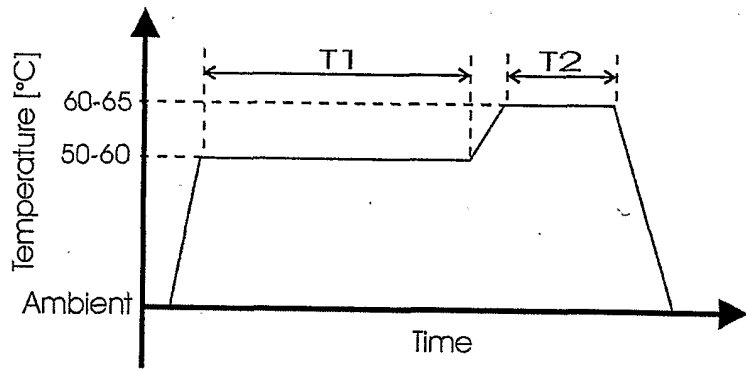

Fig. 9B

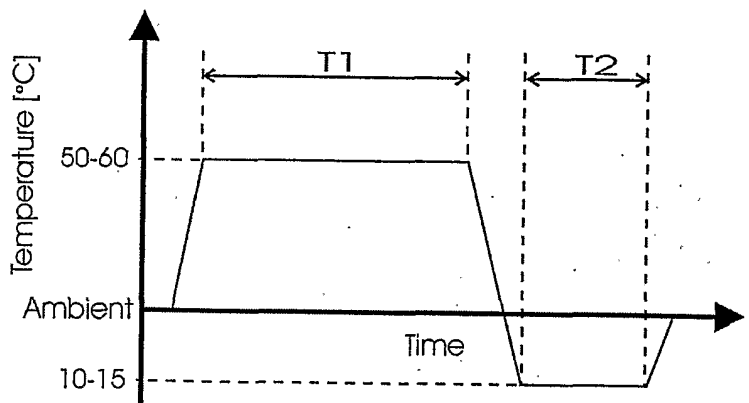

Fig. 9C

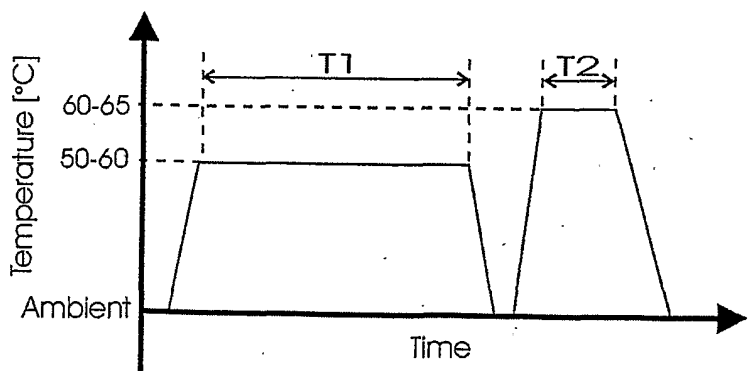

Fig. 9D

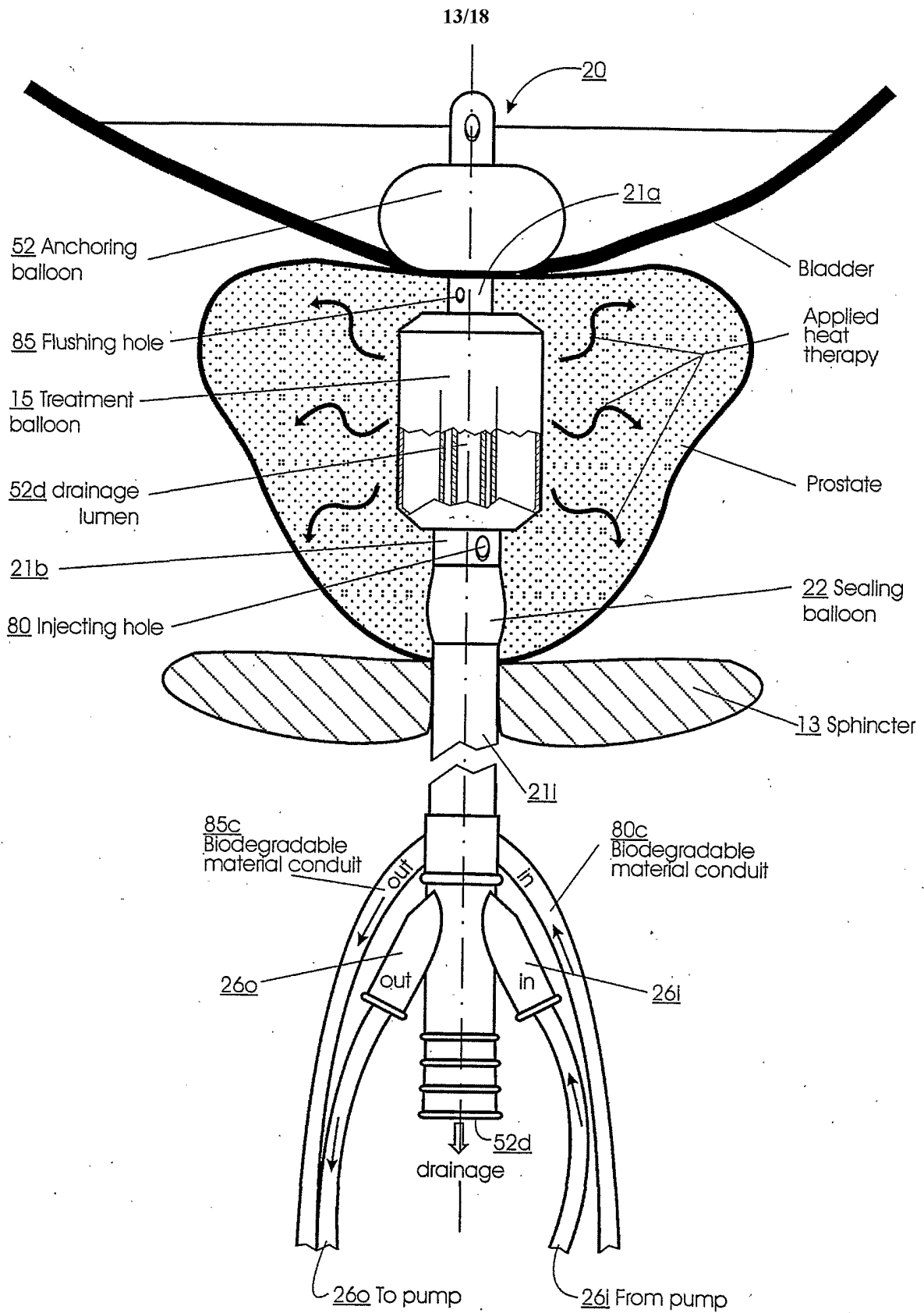

Fig. 10A

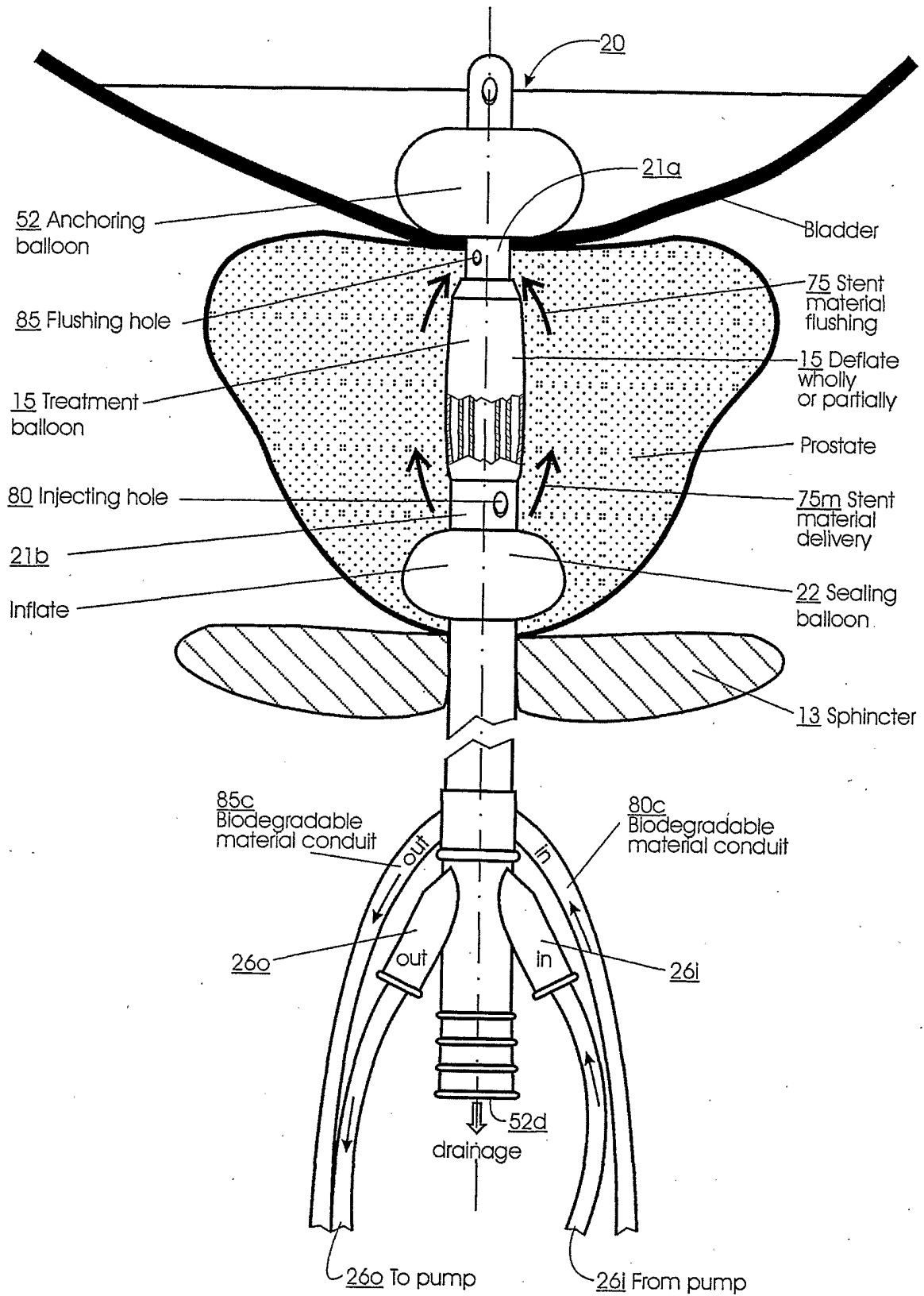

Fig. 10B

15/18

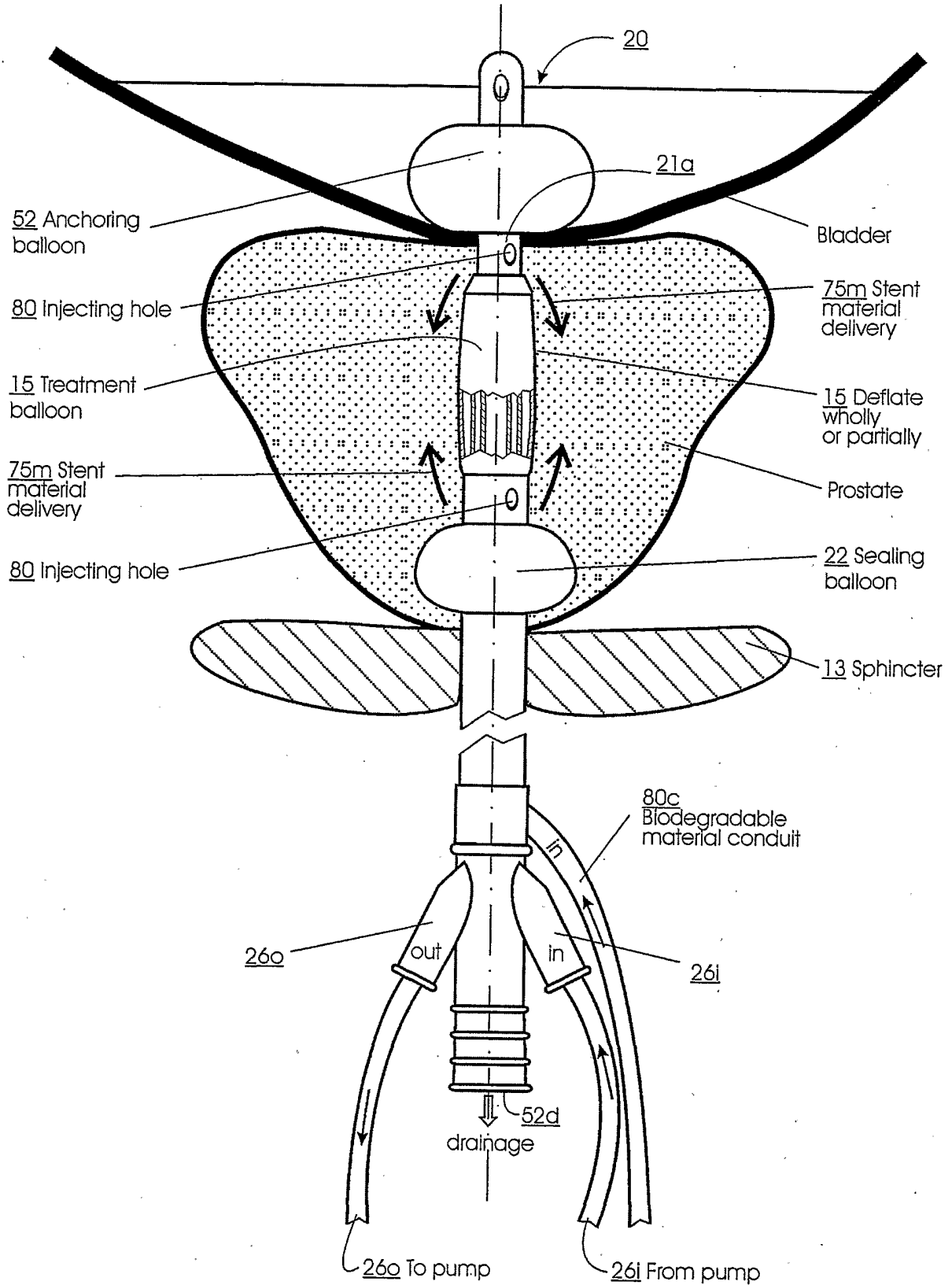

Fig. 10C

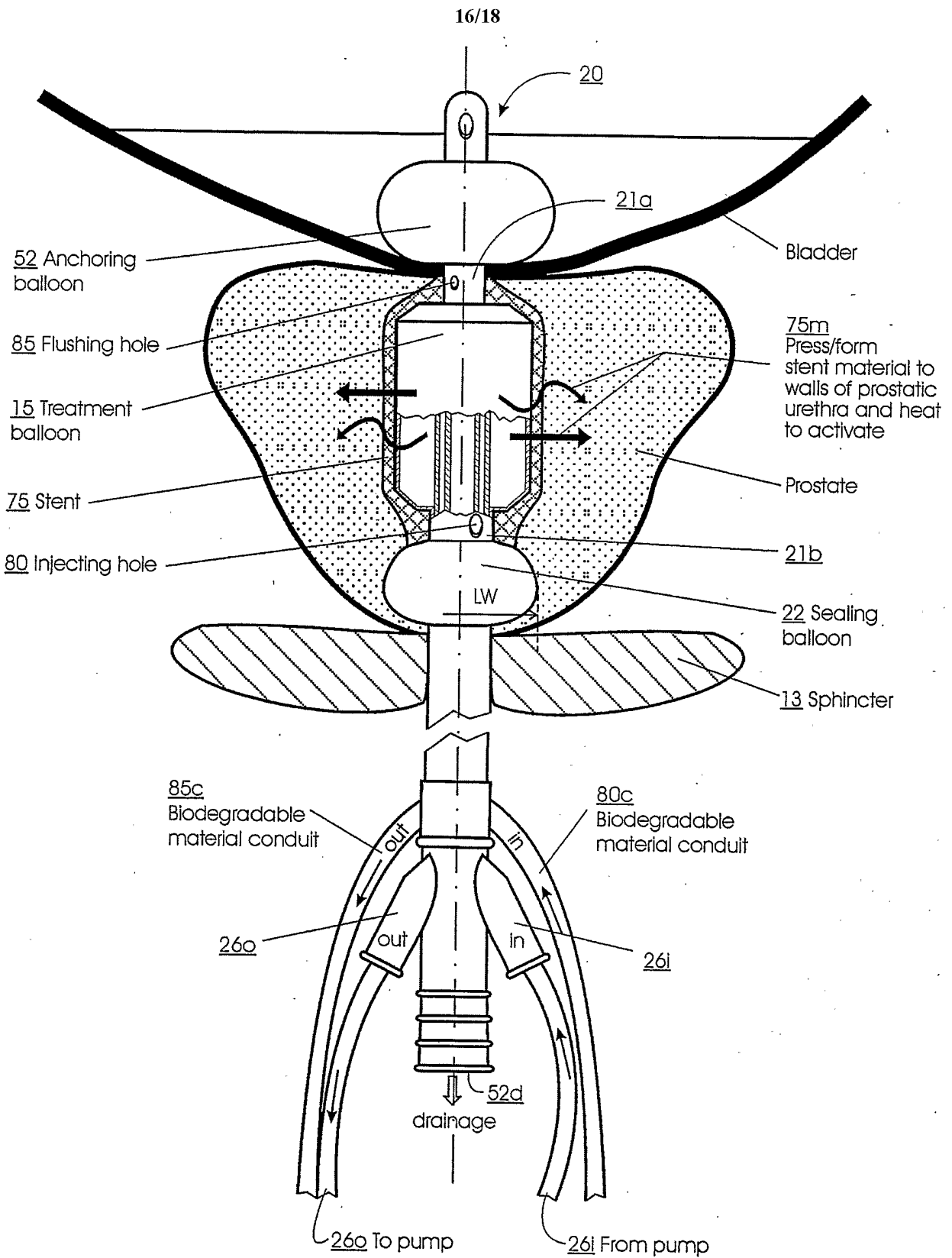

Fig. 10D

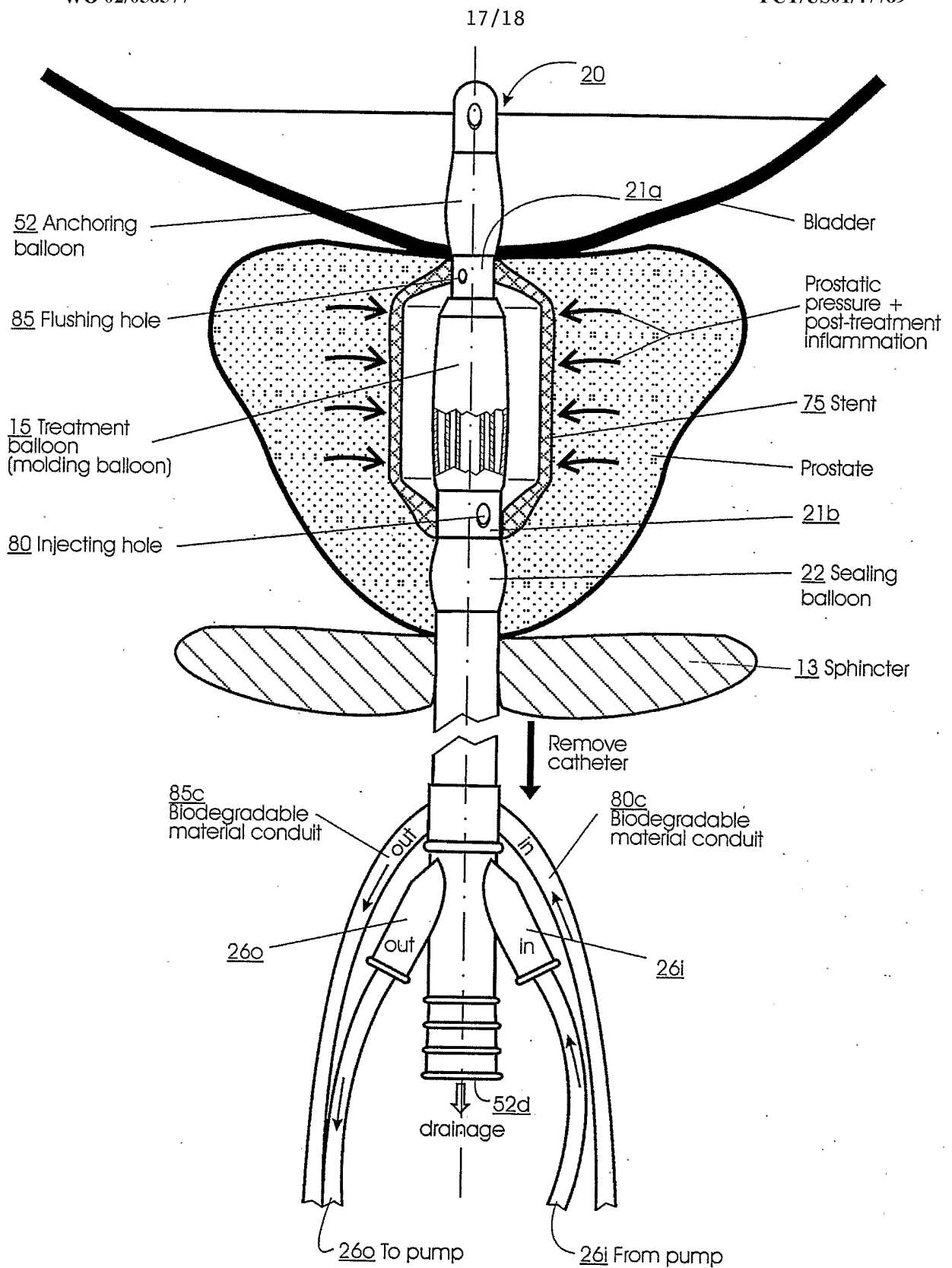

Fig. 10E

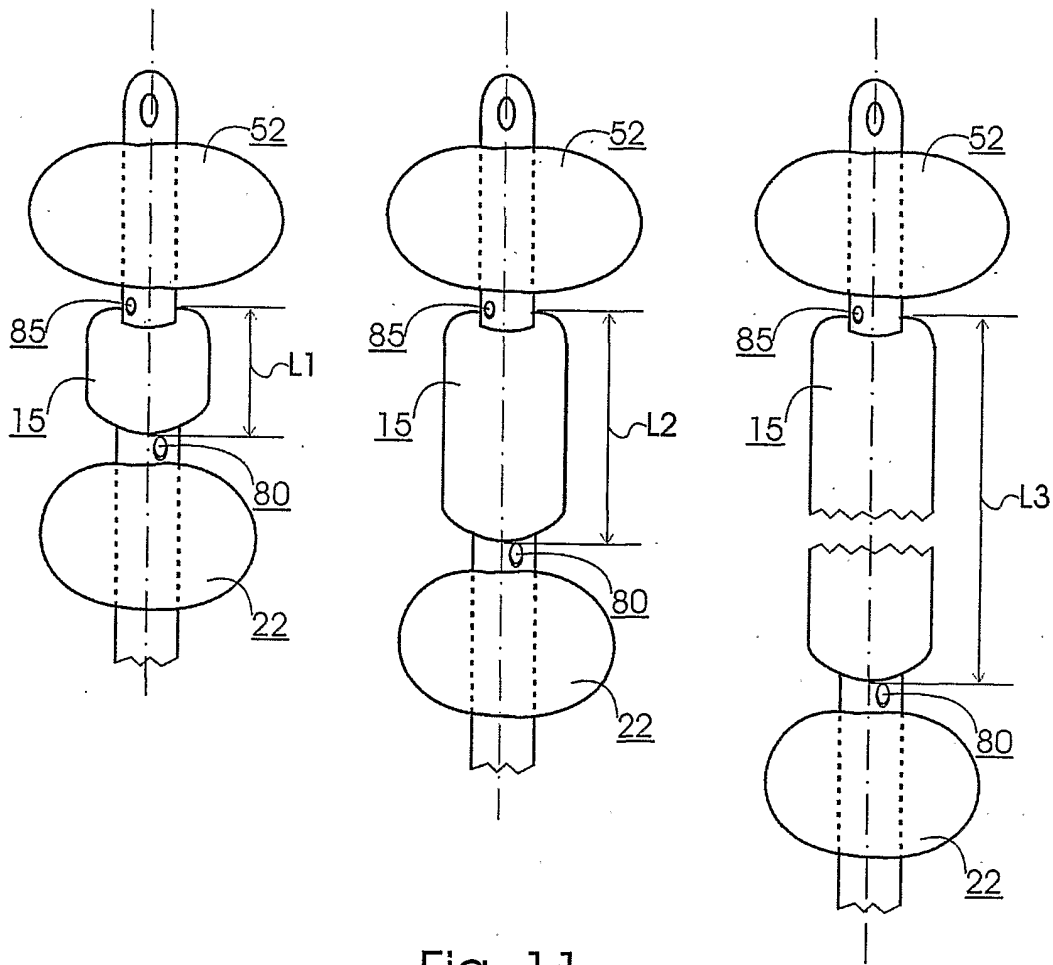

Fig. 11

INTERNATIONAL SEARCH REPORT

International Application No
PCT/US 01/47789A. CLASSIFICATION OF SUBJECT MATTER
IPC 7 A61B18/08 A61F2/06

According to International Patent Classification (IPC) or to both national classification and IPC

B. FIELDS SEARCHED

Minimum documentation searched (classification system followed by classification symbols)
IPC 7 A61B A61F

Documentation searched other than minimum documentation to the extent that such documents are included in the fields searched

Electronic data base consulted during the international search (name of data base and, where practical, search terms used)

EPO-Internal, PAJ, WPI Data

C. DOCUMENTS CONSIDERED TO BE RELEVANT

Category °	Citation of document, with indication, where appropriate, of the relevant passages	Relevant to claim No.
A	WO 97 02794 A (LUND INSTR AB ;BOLMSJOE MAGNUS (SE)) 30 January 1997 (1997-01-30) see ref signs 10,16, 22, 31 abstract; figure 1	36,40, 42,44
X	US 5 899 917 A (KUCKLICK THEODORE ET AL) 4 May 1999 (1999-05-04) abstract column 24, line 66 -column 25, line 13	44
A	US 5 509 929 A (PERRIN PAUL ET AL) 23 April 1996 (1996-04-23) description of fig. 7 column 11, line 55-65; figures 4,7	36,40, 42,44
A	EP 0 449 472 A (ARGOMED LTD) 2 October 1991 (1991-10-02) abstract; figure 10	36

 Further documents are listed in the continuation of box C. Patent family members are listed in annex.

° Special categories of cited documents :

- *A* document defining the general state of the art which is not considered to be of particular relevance
- *E* earlier document but published on or after the international filing date
- *L* document which may throw doubts on priority claim(s) or which is cited to establish the publication date of another citation or other special reason (as specified)
- *O* document referring to an oral disclosure, use, exhibition or other means
- *P* document published prior to the international filing date but later than the priority date claimed

- *T* later document published after the international filing date or priority date and not in conflict with the application but cited to understand the principle or theory underlying the invention
- *X* document of particular relevance; the claimed invention cannot be considered novel or cannot be considered to involve an inventive step when the document is taken alone
- *Y* document of particular relevance; the claimed invention cannot be considered to involve an inventive step when the document is combined with one or more other such documents, such combination being obvious to a person skilled in the art.
- *&* document member of the same patent family

Date of the actual completion of the international search

11 June 2002

Date of mailing of the international search report

19/06/2002

Name and mailing address of the ISA

European Patent Office, P.B. 5818 Patentlaan 2
NL - 2280 HV Rijswijk
Tel. (+31-70) 340-2040, Tx. 31 651 epo nl,
Fax: (+31-70) 340-3016

Authorized officer

Papone, F

INTERNATIONAL SEARCH REPORT

International application No.
PCT/US 01/47789

Box I Observations where certain claims were found unsearchable (Continuation of item 1 of first sheet)

This International Search Report has not been established in respect of certain claims under Article 17(2)(a) for the following reasons:

1. Claims Nos.: 1-35
because they relate to subject matter not required to be searched by this Authority, namely:
Rule 39.1(iv) PCT - Method for treatment of the human or animal body by surgery
2. Claims Nos.:
because they relate to parts of the International Application that do not comply with the prescribed requirements to such an extent that no meaningful International Search can be carried out, specifically:
3. Claims Nos.:
because they are dependent claims and are not drafted in accordance with the second and third sentences of Rule 6.4(a).

Box II Observations where unity of invention is lacking (Continuation of item 2 of first sheet)

This International Searching Authority found multiple inventions in this international application, as follows:

1. As all required additional search fees were timely paid by the applicant, this International Search Report covers all searchable claims.
2. As all searchable claims could be searched without effort justifying an additional fee, this Authority did not invite payment of any additional fee.
3. As only some of the required additional search fees were timely paid by the applicant, this International Search Report covers only those claims for which fees were paid, specifically claims Nos.:
4. No required additional search fees were timely paid by the applicant. Consequently, this International Search Report is restricted to the invention first mentioned in the claims; it is covered by claims Nos.:

Remark on Protest

- The additional search fees were accompanied by the applicant's protest.
- No protest accompanied the payment of additional search fees.

INTERNATIONAL SEARCH REPORT

Information on patent family members

International Application No

PCT/US 01/47789

Patent document cited in search report		Publication date	Patent family member(s)	Publication date
WO 9702794	A	30-01-1997	SE 507465 C2	08-06-1998
			AU 700815 B2	14-01-1999
			AU 6372296 A	10-02-1997
			CA 2225561 A1	30-01-1997
			CN 1190340 A	12-08-1998
			EP 0955969 A1	17-11-1999
			JP 11508798 T	03-08-1999
			SE 9502523 A	08-01-1997
			WO 9702794 A1	30-01-1997
			US 5899917	A
AU 6458798 A	29-09-1998			
AU 6698398 A	29-09-1998			
WO 9840033 A2	17-09-1998			
WO 9840034 A1	17-09-1998			
US 6315776 B1	13-11-2001			
US 5509929	A	23-04-1996	CA 2031740 A1	08-06-1992
			FR 2639238 A1	25-05-1990
			FR 2659519 A1	13-09-1991
			FR 2693116 A1	07-01-1994
			US 5234004 A	10-08-1993
			WO 9401177 A1	20-01-1994
			AT 129910 T	15-11-1995
			DE 68924760 D1	14-12-1995
			DE 68924760 T2	11-04-1996
			EP 0370890 A1	30-05-1990
			EP 0459535 A2	04-12-1991
			ES 2022063 T3	01-10-1996
			GR 3018153 T3	29-02-1996
			JP 2180279 A	13-07-1990
			US 5480417 A	02-01-1996
			DE 8916291 U1	25-09-1997
			DE 370890 T1	27-09-1990
			GR 91300117 T1	20-03-1992
			AT 112973 T	15-11-1994
			CA 2082497 A1	13-09-1991
			DE 69104714 D1	24-11-1994
			DE 69104714 T2	01-06-1995
			WO 9113650 A1	19-09-1991
EP 0519958 A1	30-12-1992			
KR 190933 B1	01-06-1999			
EP 0449472	A	02-10-1991	IL 93842 A	31-10-1995
			AT 131027 T	15-12-1995
			DE 69115096 D1	18-01-1996
			DE 69115096 T2	22-08-1996
			DK 449472 T3	22-04-1996
			EP 0449472 A1	02-10-1991
			ES 2083522 T3	16-04-1996
			JP 3272373 B2	08-04-2002
			JP 7067908 A	14-03-1995
			US 5549559 A	27-08-1996
			US RE37704 E1	14-05-2002
			US 5257977 A	02-11-1993