

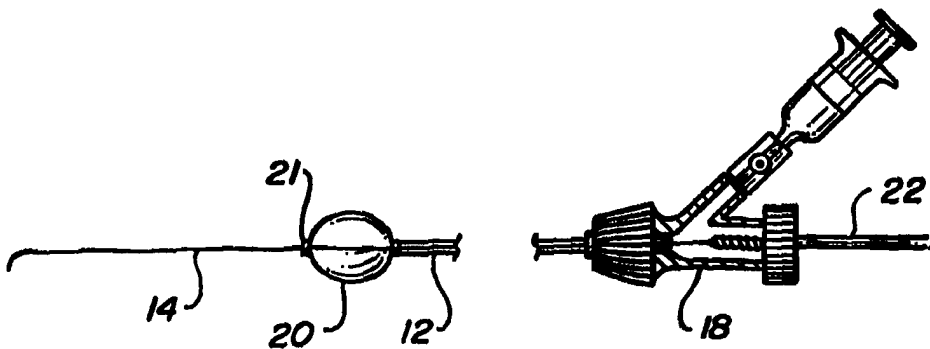

INTERNATIONAL APPLICATION PUBLISHED UNDER THE PATENT COOPERATION TREATY (PCT)

<p>(51) International Patent Classification⁶ : A61M 31/00</p>	<p>A1</p>	<p>(11) International Publication Number: WO 98/26833</p> <p>(43) International Publication Date: 25 June 1998 (25.06.98)</p>
<p>(21) International Application Number: PCT/US97/23257</p> <p>(22) International Filing Date: 16 December 1997 (16.12.97)</p> <p>(30) Priority Data: 08/767,221 16 December 1996 (16.12.96) US 08/906,890 6 August 1997 (06.08.97) US</p> <p>(71) Applicant (for all designated States except US): UNIVERSITY OF CALIFORNIA AT LOS ANGELES [US/US]; Office of Intellectual Property Administration, 1400 Ueberroth Building, 405 Hilgard Avenue, Los Angeles, CA 90024-1406 (US).</p> <p>(72) Inventor; and (75) Inventor/Applicant (for US only): TEITELBAUM, George, P. [US/US]; 10960 Ashton Avenue #402, Los Angeles, CA 90024 (US).</p> <p>(74) Agents: FARAH, David, A. et al.; Sheldon & Mak, 9th floor, 225 South Lake Avenue, Pasadena, CA 91101 (US).</p>		<p>(81) Designated States: AL, AM, AT, AU, AZ, BA, BB, BG, BR, BY, CA, CH, CN, CU, CZ, DE, DK, EE, ES, FI, GB, GE, GH, HU, ID, IL, IS, JP, KE, KG, KP, KR, KZ, LC, LK, LR, LS, LT, LU, LV, MD, MG, MK, MN, MW, MX, NO, NZ, PL, PT, RO, RU, SD, SE, SG, SI, SK, SL, TJ, TM, TR, TT, UA, UG, US, UZ, VN, YU, ZW, ARIPO patent (GH, GM, KE, LS, MW, SD, SZ, UG, ZW), Eurasian patent (AM, AZ, BY, KG, KZ, MD, RU, TJ, TM), European patent (AT, BE, CH, DE, DK, ES, FI, FR, GB, GR, IE, IT, LU, MC, NL, PT, SE), OAPI patent (BF, BJ, CF, CG, CI, CM, GA, GN, ML, MR, NE, SN, TD, TG).</p> <p>Published With international search report.</p>

(54) Title: ANGIOPLASTY CATHETER



(57) Abstract

This invention is a device for crossing a stenotic intravascular lesion for occluding blood flow downstream from the intravascular lesion, and for use as an exchange guide wire, and a method of using the device; the device comprising a balloon catheter (10) having a catheter body with an inflation conduit, an inflation balloon (20), an adapter (18) for inflating the inflation balloon, and an extension member (22). The device is configured such that the inflation balloon is maintained in an inflated state by connecting the extension member (22) to the proximal end of the inflation conduit when the adapter is removed.

FOR THE PURPOSES OF INFORMATION ONLY

Codes used to identify States party to the PCT on the front pages of pamphlets publishing international applications under the PCT.

AL	Albania	ES	Spain	LS	Lesotho	SI	Slovenia
AM	Armenia	FI	Finland	LT	Lithuania	SK	Slovakia
AT	Austria	FR	France	LU	Luxembourg	SN	Senegal
AU	Australia	GA	Gabon	LV	Latvia	SZ	Swaziland
AZ	Azerbaijan	GB	United Kingdom	MC	Monaco	TD	Chad
BA	Bosnia and Herzegovina	GE	Georgia	MD	Republic of Moldova	TG	Togo
BB	Barbados	GH	Ghana	MG	Madagascar	TJ	Tajikistan
BE	Belgium	GN	Guinea	MK	The former Yugoslav Republic of Macedonia	TM	Turkmenistan
BF	Burkina Faso	GR	Greece	ML	Mali	TR	Turkey
BG	Bulgaria	HU	Hungary	MN	Mongolia	TT	Trinidad and Tobago
BJ	Benin	IE	Ireland	MR	Mauritania	UA	Ukraine
BR	Brazil	IL	Israel	MW	Malawi	UG	Uganda
BY	Belarus	IS	Iceland	MX	Mexico	US	United States of America
CA	Canada	IT	Italy	NE	Niger	UZ	Uzbekistan
CF	Central African Republic	JP	Japan	NL	Netherlands	VN	Viet Nam
CG	Congo	KE	Kenya	NO	Norway	YU	Yugoslavia
CH	Switzerland	KG	Kyrgyzstan	NZ	New Zealand	ZW	Zimbabwe
CI	Côte d'Ivoire	KP	Democratic People's Republic of Korea	PL	Poland		
CM	Cameroon	KR	Republic of Korea	PT	Portugal		
CN	China	KZ	Kazakstan	RO	Romania		
CU	Cuba	LC	Saint Lucia	RU	Russian Federation		
CZ	Czech Republic	LI	Liechtenstein	SD	Sudan		
DE	Germany	LK	Sri Lanka	SE	Sweden		
DK	Denmark	LR	Liberia	SG	Singapore		
EE	Estonia						

ANGIOPLASTY CATHETER

CROSS-REFERENCE TO RELATED APPLICATIONS

The present Application is an International Application corresponding to pending United States Patent Application 08/906,890, entitled "Angioplasty Catheter," filed August 6, 1997; which is a continuation of United States Patent Application 08/767,221, 5 entitled "Cerebral Protection Balloon for Use in Carotid Artery Angioplasty and Stenting", filed December 16, 1996, now abandoned, the contents of which are incorporated herein by reference in their entirety.

BACKGROUND

Field of The Invention

10 This invention relates to the field of carotid artery angioplasty, and particularly to a method and apparatus for preventing debris created by a carotid artery angioplasty procedure from entering the internal carotid artery.

Prior Art

15 The mainstay of treatment for carotid artery bifurcation atherosclerotic stenosis (in order to prevent stroke) is surgical carotid endarterectomy, in which a small incision is made in the carotid artery large enough to allow scooping out of atherosclerotic deposits within the artery wall. The incision within the artery wall is then sutured closed, allowing restoration of normal blood flow. If an endovascular means could be developed that matched the safety of surgical endarterectomy, then this procedure could be performed by a non-operative route, 20 possibly saving thousands of dollars for each patient's hospital stay (since most patients could be discharged within one day of the endovascular procedure).

Various endovascular procedures have been proposed. For example, U.S. Patent No. 4,650,466 issued to Luther discloses an angioplasty device comprising a woven 25 tube of metal or plastic fibers. One or more guidewires for a stylet are attached to the woven tube for rotation and manipulation inside an artery. When the stylet or guidewires are retracted, the woven tube expands and contacts the interior, plaque-coated wall of the artery. Movement of the guidewires and expanded woven tube abrades atherosclerotic plaque from the artery to form particles that are trapped within the tube. Removal of the angioplasty device from the artery thereby removes the atherosclerotic articles from the patient.

30 Another endovascular approach is disclosed in U.S. Patent No. 4,765,332

issued to Fischel et al. A pull-back atherectomy catheter cuts and collects obstructed material as the catheter is pulled back through an atherosclerotic stenosis.

The most commonly used endovascular procedure is balloon angioplasty and stenting. Most scientific studies of carotid balloon angioplasty and stenting report a 2-6% stroke rate. A re-stenosis rate associated with surgical endarterectomy may vary between 1 and 5% and the long-term re-stenosis rate of the carotid artery following endarterectomy has been reported to be 5-11% within several years following the procedure. Dr. Jacques Theron has reported on the use of an occlusion balloon which is placed distally within the internal carotid artery during dilatation of this vessel in order to prevent stroke related to carotid artery angioplasty. He reports a nearly zero percent stroke rate when this technique is used. The problem with the use of his triaxial balloon technique is that the balloon cannot be kept inflated continuously in between pre-dilatation of the atherosclerotic stenosis and stenting of the vessel. If a balloon catheter could be kept inflated within the internal carotid artery and still be used as an exchange guidewire to permit the exchange of multiple different catheter devices to complete balloon dilatation and stenting of the internal carotid artery, then this would be a major advance in the technique.

SUMMARY

The present invention provides a device which combines an occlusion balloon to block antegrade flow of blood in the internal carotid artery during an angioplasty procedure with an exchange guidewire to facilitate the insertion of devices for performing the angioplasty procedure. The occlusion balloon/guidewire device of the present invention comprises a microcatheter with a soft platinum guidewire extending therein. A silicone occlusion balloon is attached to the distal end of the microcatheter. A self-sealing valve at the distal end of the balloon permits the guidewire to extend distally therefrom. A Tuohy-Borst adapter is attached to the proximal end of the microcatheter to permit inflation of the occlusion balloon. A guidewire extension is inserted through the Tuohy-Borst adapter to seal the microcatheter once the balloon has been inflated. The Tuohy-Borst adapter is then removed over the guidewire extension member allowing the microcatheter to be utilized as an exchange guidewire.

FIGURES

Figure 1 is a side elevation view of an occlusion balloon/guidewire device according to the present invention;

Figure 2 illustrates inflation of the occlusion balloon of the device of Figure 1;

Figure 3 is an enlarged view illustrating attachment of the guidewire extension member of the present invention;

Figure 4 illustrates attachment of a threaded embodiment of the guidewire extension member;

5 Figure 5 illustrates attachment of a friction-fit embodiment of the guidewire extension member;

Figure 6 illustrates removal of the Tuohy-Borst adapter to permit the device of the present invention to be used as an exchange guidewire;

10 Figure 7 illustrates insertion of a guiding catheter into the common carotid artery;

Figure 8 illustrates insertion of the occlusion balloon/guidewire device of the present invention into the site of an arterial stenosis;

Figure 9 illustrates inflation of the occlusion balloon and deployment of a balloon catheter at site of the arterial stenosis;

15 Figure 10 illustrates deployment of an endovascular stent at the site of the arterial stenosis; and

Figure 11 illustrates flushing of the angioplasty site prior to the deflation of the occlusion balloon.

DESCRIPTION

20 In the following description, for purposes of explanation and not limitation, specific details are set forth in order to provide a thorough understanding of the present invention. However, it will be apparent to one skilled in the art that the present invention may be practiced in other embodiments that depart from these specific details. In other instances, detailed descriptions of well-known methods and devices are omitted so as to not obscure the
25 description of the present invention with unnecessary detail.

The occlusion balloon/guidewire device 10 of the present invention is shown generally in Figure 1. The microcatheter 12 has a maximum diameter of approximately 0.089 cm, i.e, slightly less than 3-French in greatest outer diameter. It is approximately 300 cm long. A 0.025 cm to 0.036 cm (OD) soft platinum balloon/guidewire device 14 extends from
30 the distal tip 13 of the microcatheter 12. This permits use of a steering device 16 on the more proximal portion of the catheter so that the soft platinum wire tip can be navigated past a tight carotid stenosis using digital road map imaging. Occlusion balloon 20 is disposed at the distal

end of catheter 12. The balloon 20 is made out of high compliance silicone and is designed to inflate with low pressures (less than 1 atmosphere). A self-sealing rubberized valve 21 seals the distal end of balloon 20 around guidewire 14.

Referring next to Figure 2, a removable Tuohy-Borst adapter 18 is disposed at the proximal portion of the device 10 for inflating the distal balloon tip 20 of the catheter. Once inflated with dilute contrast solution, the balloon is kept inflated by the insertion of a proximal 0.089 cm (OD) stainless steel extension 22 of the guidewire as more clearly shown in Figure 3. In one embodiment, as shown in Figure 4, the extension member has a threaded segment 24. The extension member is passed through the Tuohy-Borst adapter and inserted into the proximal end 11 of the occlusion balloon/guidewire device 10. The proximal end 11 of this device has a threaded inner lumen so that the guidewire extension device can be threaded into the occlusion balloon/guidewire device, thus sealing the contrast solution within its central lumen and keeping the balloon 20 inflated. The Tuohy-Borst adapter may then be loosened and removed from the occlusion balloon/guidewire device with the balloon still left inflated. Thus, with the Tuohy-Borst adapter removed, this catheter, together with its inflated balloon, can now be used as an exchange guidewire. Alternatively, as shown in Figure 5, the distal end of guidewire extension member 22 may have a smooth exterior with an OD greater than 0.036 cm but less than 0.089 cm for a press fit within the lumen of catheter 12. Once inserted into the proximal microcatheter lumen, where it would lock in by friction, inflation of the distal balloon 20 is maintained.

Figures 7-11 illustrate the use of device 10 in a carotid artery angioplasty procedure. The patient is systemically heparinized during the procedure. Via the femoral approach, a long 9-French access sheath is inserted through the common femoral artery and is advanced into the abdominal aorta. Through this long 9-French sheath, a 5-7 French selective catheter is used to access the common carotid artery on the side of carotid artery stenosis. Through this catheter, contrast arteriography of the carotid bifurcation is performed demonstrating the exact location of the narrowed area of the carotid artery. Next, over a 0.089 cm OD exchange guidewire, the selective catheter is exchanged for a 9-French guiding catheter 30. The 9-French catheter is advanced to the distal portion of the common carotid artery as shown in Figure 7. There, using digital road map imaging, the balloon occlusion/guidewire device 10 is coaxially inserted through the 9-French guiding catheter.

With reference now to Figure 8, the soft steerable platinum guidewire tip 14 is

used to advance device 10, past the area of stenosis into the more distal cervical portion of the carotid artery. In this location, the balloon tip 20 of the balloon occlusion/guidewire device is inflated with dilute contrast through the Tuohy-Borst device attached to its proximal end.

Once it is determined that there is antegrade flow arrest within the internal carotid artery, the 0.089 cm guidewire extension 22 is inserted into the proximal end of the device and screwed or pressed into place, thus maintaining balloon inflation. The Tuohy-Borst device is then removed from the proximal portion of the balloon occlusion/guidewire device.

At this point, as shown in Figure 9, a balloon angioplasty catheter 32 is inserted through the 9-French guiding catheter 30 over the balloon occlusion/guidewire device 10 to pre-dilate the carotid stenosis. Alternatively, a balloon catheter with a Palmaz stent mounted on its uninflated balloon could be used, or a Wall stent device could be advanced over device 10 to the area of stenosis for dilatation and stenting of the lesion. By whichever procedure is utilized, stent 34 is deployed at the area of stenosis as shown in Figure 10. Debris created by the balloon angioplasty and stent placement procedure is trapped proximally to occlusion balloon 20.

Following dilatation of the stenosis and deployment of the endovascular stent 34, the stent delivery device is removed from the exchange guidewire and vigorous flushing of the angioplasty and stenting site is performed as illustrated in Figure 11. A large volume of saline is injected through the 9-French guiding catheter, which flushes any microscopic debris created by the angioplasty and stenting into the ipsilateral external carotid artery. Next, the guidewire extension device 22 is unscrewed from the proximal end of device 10, thus allowing deflation of the silicone balloon and also restoring antegrade flow within the internal carotid artery. The balloon occlusion/guidewire device together with the 9-French guiding catheter is then removed from the groin sheath and the groin sheath is removed from the patient, following reversal of systemic heparinization. Hemostasis in the inguinal area is effected by manual compression.

It will be recognized that the above described invention may be embodied in other specific forms without departing from the spirit or essential characteristics of the disclosure. Thus, it is understood that the invention is not to be limited by the foregoing illustrative details, but rather is to be defined by the appended claims.

WHAT IS CLAIMED IS:

1. A device for crossing a stenotic intravascular lesion, for occluding blood flow downstream from the intravascular lesion and for use as an exchange guidewire, the device comprising:

5 a balloon catheter having a catheter body with a proximal end and a distal end, an inflation balloon attached at or near the distal end of the catheter body, and an inflation conduit within the catheter body connecting the inflation balloon with the proximal end of the balloon catheter;

10 an adapter for inflating the inflation balloon, the adapter configured to be removably connectable to the proximal end of the balloon catheter; and

a extension member having a distal end configured to be removably connectable to the proximal end of the balloon catheter for sealing the proximal end of the inflation conduit;

15 wherein the device is configured such that, after inflating the inflation balloon, the inflation of the inflation balloon is maintained by connecting the extension member to the proximal end of the inflation conduit when the adapter is removed.

2. The device of claim 1, wherein the adapter is a Tuohy-Borst adapter.

20 3. The device of claim 1, wherein the distal end of the extension member has an external thread and the proximal end of the inflation conduit has an internal thread allowing the distal end of the extension member and proximal end of the inflation conduit to be threadedly connected to each other.

4. The device of claim 1, wherein the distal end of the extension member has a substantially smooth external surface and the proximal end of the inflation conduit has a substantially smooth internal surface, and where the external surface and internal surface are configured to sealing connect by friction.

25 5. A method of performing an intravascular procedure comprising the steps of:

(a) providing a catheter according to claim 1;

(b) inserting the catheter into a blood vessel and advancing the catheter to a selected position within the blood vessel;

(c) inflating the inflation balloon to occlude blood flow in the blood vessel;

30 (d) connecting the extension member to the proximal end of the inflation conduit; and

(e) removing the adapter.

6. The method of claim 5, additionally comprising the step of placing a stent

intravascularly after the inflating step.

7. The method of claim 5, additionally comprising the step of flushing debris from the blood vessel after the inflating step.

8. The method of claim 5, additionally comprising the step of disconnecting the extension member from the proximal end of the inflation conduit, thereby deflating the inflation balloon and restoring blood flow within the blood vessel.

9. A method of performing an intravascular procedure comprising the steps of:

(a) providing a device including, i) a balloon catheter having a catheter body with a proximal end and a distal end, an inflation balloon attached at or near the distal end of the catheter body, and an inflation conduit within the catheter body connecting the inflation balloon with the proximal end of the balloon catheter; ii) an adapter for inflating the inflation balloon, the adapter configured to be removably connectable to the proximal end of the balloon catheter; and iii) an extension member having a distal end configured to be removably connectable to the proximal end of the balloon catheter for sealing the proximal end of the inflation conduit; wherein the device is configured such that, after inflating the inflation balloon, the inflation of the inflation balloon is maintained by connecting the extension member to the proximal end of the inflation conduit when the adapter is removed, thereby allowing the catheter body to function as an exchange guidewire while inflation of the inflation balloon is maintained;

(b) inserting the catheter into a blood vessel and advancing the catheter to a selected position within the blood vessel;

(c) inflating the inflation balloon to occlude blood flow in the blood vessel;

(d) connecting the extension member to the proximal end of the inflation conduit; and

(e) removing the adapter.

10. The method of claim 9, additionally comprising the step of placing a stent intravascularly after the inflating step.

11. The method of claim 9, additionally comprising the step of flushing debris from the blood vessel after the inflating step.

12. The method of claim 9, additionally comprising the step of disconnecting the extension member from the proximal end of the inflation conduit, thereby deflating the inflation balloon and restoring blood flow within the blood vessel.

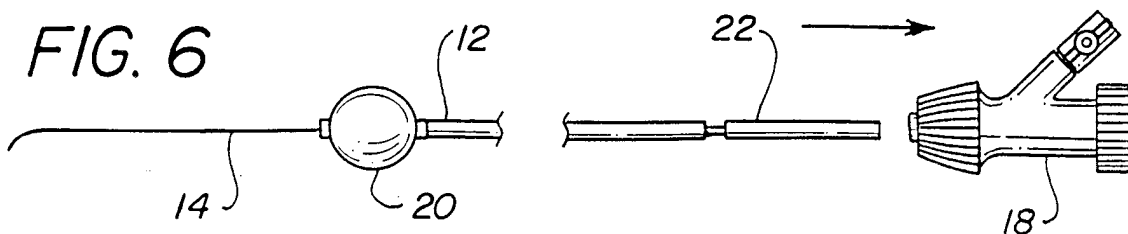
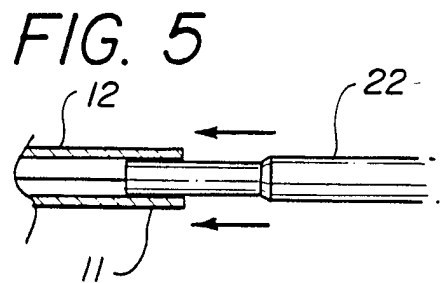
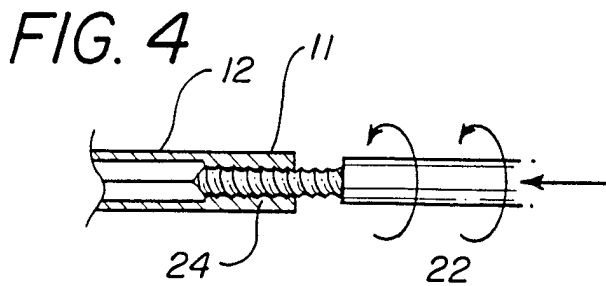
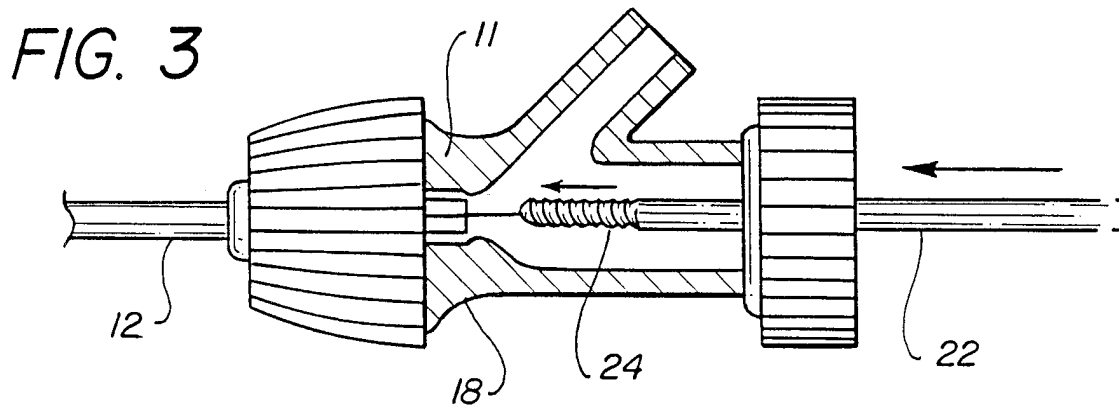
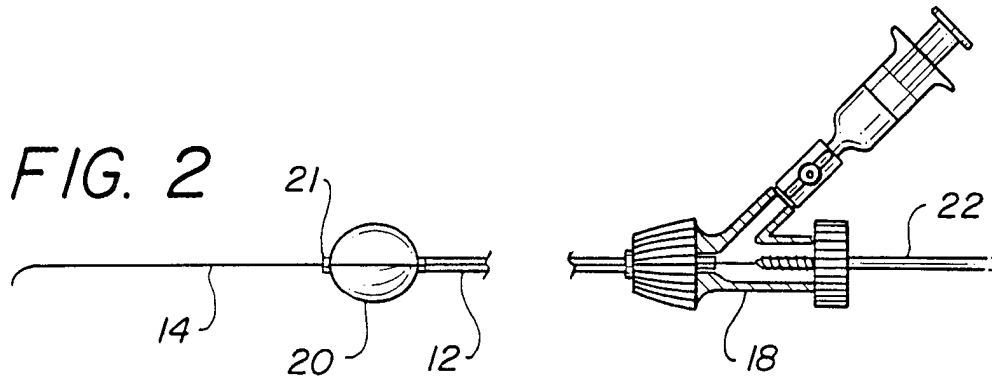
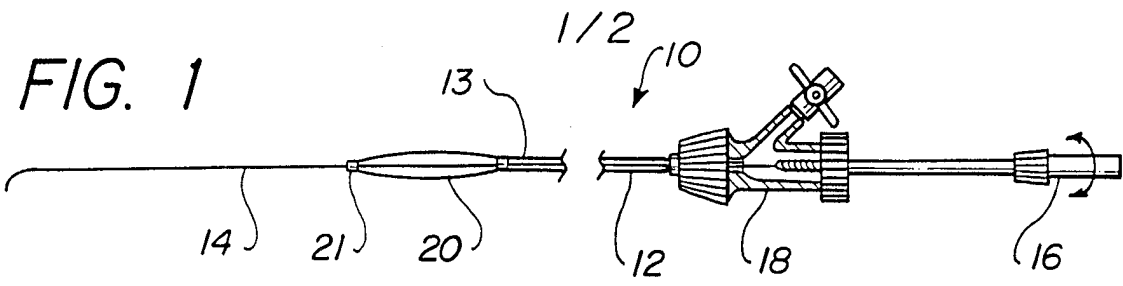

FIG. 7

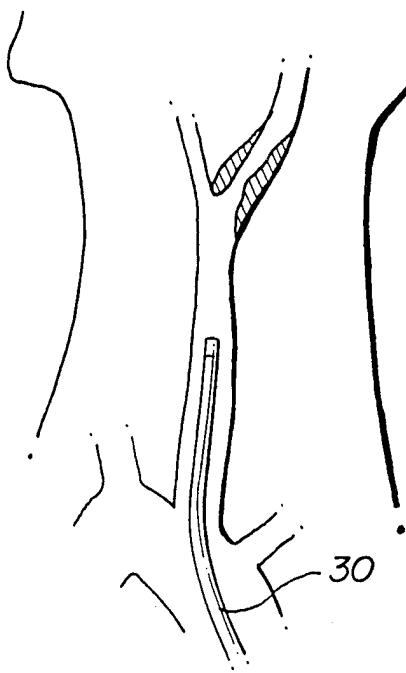

FIG. 8

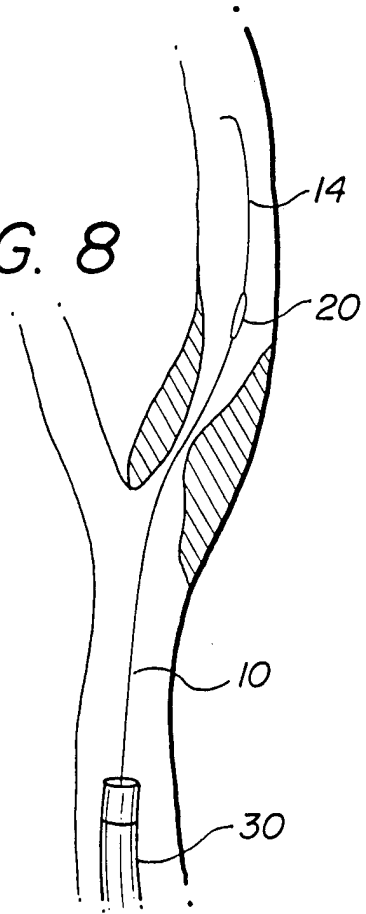

FIG. 9

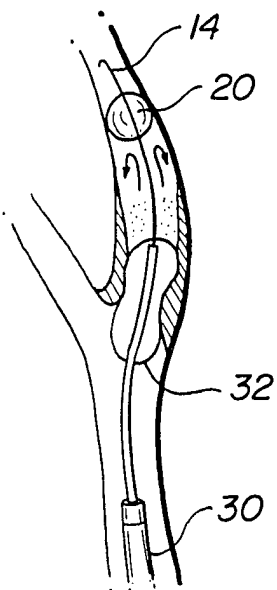

FIG. 10

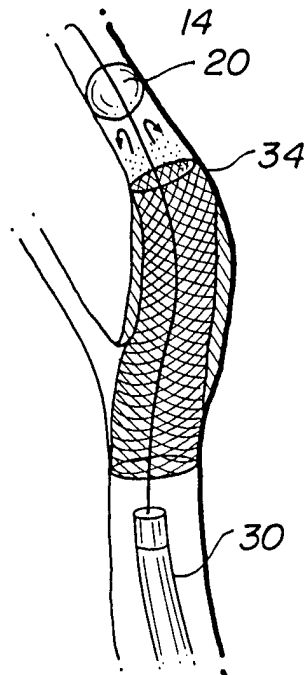
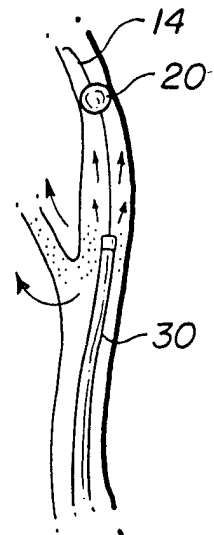

FIG. 11



INTERNATIONAL SEARCH REPORT

International application No.
PCT/US97/23257

A. CLASSIFICATION OF SUBJECT MATTER
 IPC(6) :A61M 31/00
 US CL :604/49
 According to International Patent Classification (IPC) or to both national classification and IPC

B. FIELDS SEARCHED

Minimum documentation searched (classification system followed by classification symbols)
 U.S. : 604/95--98, 104, 264, 280, 283

Documentation searched other than minimum documentation to the extent that such documents are included in the fields searched

Electronic data base consulted during the international search (name of data base and, where practicable, search terms used)

C. DOCUMENTS CONSIDERED TO BE RELEVANT

Category*	Citation of document, with indication, where appropriate, of the relevant passages	Relevant to claim No.
A	US 4,650,466 A (LUTHER) 17 March 1987, entire document.	1-12
A	US 4,765,332 A (FISCHELL et al) 23 August 1988, entire document.	1-12

Further documents are listed in the continuation of Box C. See patent family annex.

* Special categories of cited documents:	*T* later document published after the international filing date or priority date and not in conflict with the application but cited to understand the principle or theory underlying the invention
A document defining the general state of the art which is not considered to be of particular relevance	*X* document of particular relevance; the claimed invention cannot be considered novel or cannot be considered to involve an inventive step when the document is taken alone
E earlier document published on or after the international filing date	*Y* document of particular relevance; the claimed invention cannot be considered to involve an inventive step when the document is combined with one or more other such documents, such combination being obvious to a person skilled in the art
L document which may throw doubts on priority claim(s) or which is cited to establish the publication date of another citation or other special reason (as specified)	* & * document member of the same patent family
O document referring to an oral disclosure, use, exhibition or other means	
P document published prior to the international filing date but later than the priority date claimed	

Date of the actual completion of the international search 03 FEBRUARY 1998	Date of mailing of the international search report 24 FEB 1998
---	--

Name and mailing address of the ISA/US Commissioner of Patents and Trademarks Box PCT Washington, D.C. 20231 Facsimile No. (703) 305-3230	Authorized officer <i>John D. Yasko, Jr.</i> JOHN D. YASKO, JR. Telephone No. (703) 308-2986
---	---