



## INTERNATIONAL APPLICATION PUBLISHED UNDER THE PATENT COOPERATION TREATY (PCT)

<p>(51) International Patent Classification <sup>7</sup> : <b>A61B 17/34</b></p>	<p><b>A1</b></p>	<p>(11) International Publication Number: <b>WO 00/54677</b></p> <p>(43) International Publication Date: 21 September 2000 (21.09.00)</p>
<p>(21) International Application Number: PCT/IE00/00034</p> <p>(22) International Filing Date: 20 March 2000 (20.03.00)</p> <p>(30) Priority Data: S990218 18 March 1999 (18.03.99) IE</p> <p>(71) Applicant (for all designated States except US): GAYA LIMITED [IE/IE]; 2-3 Sandyford Village, Sandyford, Dublin 18 (IE).</p> <p>(72) Inventors; and (75) Inventors/Applicants (for US only): ROSNEY, Damien [IE/IE]; Mount Pleasant, Bluebell, Tullamore, County Offaly (IE). CUMMINS, Christy [IE/IE]; 54 Knockowen Road, Tullamore, County Offaly (IE). BERMINGHAM, Donal [IE/IE]; Ballycommon, Tullamore, County Offaly (IE).</p> <p>(74) Agent: MACLACHLAN &amp; DONALDSON; 47 Merrion Square, Dublin 2 (IE).</p>	<p>(81) Designated States: CA, JP, US, European patent (AT, BE, CH, CY, DE, DK, ES, FI, FR, GB, GR, IE, IT, LU, MC, NL, PT, SE).</p> <p><b>Published</b> <i>With international search report.</i> <i>Before the expiration of the time limit for amending the claims and to be republished in the event of the receipt of amendments.</i></p>	
<p>(54) Title: A SURGICAL ACCESS DEVICE</p>		
<p>(57) Abstract</p>		
<p>Surgical device (1) is for use in minimally invasive surgery using an inflated body cavity (2) accessible to a surgeon through the device (1) surrounding an incision in a patient's abdominal wall (3). The device engages with the cavity (2) by an anchor ring (5) and is held in position on the patient's skin by an adhesive web (6). The device (1) is sealed by a liquid filled cell (8) connected between the anchor ring (5) and the web (6). The web (6) has a connector ring (7) for additional seals and/or for holding or guiding medical instruments into position.</p>		

*FOR THE PURPOSES OF INFORMATION ONLY*

Codes used to identify States party to the PCT on the front pages of pamphlets publishing international applications under the PCT.

AL	Albania	ES	Spain	LS	Lesotho	SI	Slovenia
AM	Armenia	FI	Finland	LT	Lithuania	SK	Slovakia
AT	Austria	FR	France	LU	Luxembourg	SN	Senegal
AU	Australia	GA	Gabon	LV	Latvia	SZ	Swaziland
AZ	Azerbaijan	GB	United Kingdom	MC	Monaco	TD	Chad
BA	Bosnia and Herzegovina	GE	Georgia	MD	Republic of Moldova	TG	Togo
BB	Barbados	GH	Ghana	MG	Madagascar	TJ	Tajikistan
BE	Belgium	GN	Guinea	MK	The former Yugoslav Republic of Macedonia	TM	Turkmenistan
BF	Burkina Faso	GR	Greece			TR	Turkey
BG	Bulgaria	HU	Hungary	ML	Mali	TT	Trinidad and Tobago
BJ	Benin	IE	Ireland	MN	Mongolia	UA	Ukraine
BR	Brazil	IL	Israel	MR	Mauritania	UG	Uganda
BY	Belarus	IS	Iceland	MW	Malawi	US	United States of America
CA	Canada	IT	Italy	MX	Mexico	UZ	Uzbekistan
CF	Central African Republic	JP	Japan	NE	Niger	VN	Viet Nam
CG	Congo	KE	Kenya	NL	Netherlands	YU	Yugoslavia
CH	Switzerland	KG	Kyrgyzstan	NO	Norway	ZW	Zimbabwe
CI	Côte d'Ivoire	KP	Democratic People's Republic of Korea	NZ	New Zealand		
CM	Cameroon		Republic of Korea	PL	Poland		
CN	China	KR	Republic of Korea	PT	Portugal		
CU	Cuba	KZ	Kazakstan	RO	Romania		
CZ	Czech Republic	LC	Saint Lucia	RU	Russian Federation		
DE	Germany	LI	Liechtenstein	SD	Sudan		
DK	Denmark	LK	Sri Lanka	SE	Sweden		
EE	Estonia	LR	Liberia	SG	Singapore		

## A SURGICAL ACCESS DEVICE

The present invention relates to a surgical device for use in minimally invasive surgery of the type using patient pneumoperitoneum and an access port.

5

Minimally invasive surgery of this type is carried out having introduced gas into a patient's body cavity through an incision and sealed the incision with an access port. The access port enables laproscopic and hand or instrument assisted surgery to be performed.

10 A sleeve forming such a port is shown in WO-A-95/07056 entitled "Apparatus for use in surgery". The access port sleeve shown is used to create a controlled pressurized environment within the sleeve while allowing a surgeon's arm to pass through the sleeve. During surgery, gas is pumped into the patient's body cavity where the surgery is to be performed and the sleeve prevents gas escaping while allowing the surgeon to operate  
15 using minimally invasive surgery techniques. The application shows a sleeve having a flange at a distal end provided with adhesive for adhering the device to a patient's body or alternatively a mounting ring to surround the incision in a patient's body. While providing a suitable apparatus for performing such surgery the device described suffers from the principle disadvantage that in use, the sleeve protrudes upwardly from the patient and may  
20 interfere with the activities of the surgery team. Additionally, the sleeve must be sealed against the surgeon's upper forearm by clamping the device to the arm sufficiently tightly to avoid gas leak around the area of the seal. This presents the surgeon with a problem both in sealing the sleeve and in subsequent mobility.

25 A further problem associated with the use of sleeves of the kind described is that a phenomenon known as "tenting" may occur. "Tenting" means that when the sleeve is adhered to the patient's skin or to a surgical drape and gas is induced into the patients abdominal cavity, there is a tendency for the sleeve to fill with gas and to pull away from the patient.

30

There is therefore a need for a surgical device, which will overcome the aforementioned problems.

Accordingly, there is provided a surgical device for use in minimally invasive surgery of the type using an inflated body cavity accessible to a surgeon through an access port, defined by the device, surrounding an incision in a patients body, the device having: -

5

body cavity engagement means for insertion into the incision to locate the device in position;

fixing means for attaching the device to a patients skin; and

10

sealing means connected between the body cavity engagement means and the fixing means, the sealing means being formed to prevent substantial leakage of gas from the body cavity on inflation when in an inoperative position and formed to mould to a substantial portion of a surgeon's hand or surgical instrument on

15

insertion in an operating position.

Preferably, the body cavity engagement means is provided by an anchor ring formed for insertion into the incision.

20 Preferably, the fixing means is provided by an adhesive web or fixing ring.

In one arrangement, the fixing means has an associated connector ring for receiving additional seals or medical instruments.

25 Ideally, the sealing means is provided by a toroid cell formed to engage the incision between the fixing means and the body cavity engagement means.

Preferably, the cell forms a bladder through which the surgeon may access the body cavity, the bladder being filled with a viscous or semi-viscous liquid.

30

Preferably, the bladder is filled with saline, gel or foam.

In one embodiment, the sealing means incorporates a foam shell formed for covering the incision.

Preferably, the foam shell is formed in two parts, or as a single part partially divided along  
5 one axis, the parts being movable relatively to allow a surgeon access to the body cavity.

In one arrangement the foam shell is formed by a plurality of individually disengageable layers. In this way the surgeon can adjust the height of the foam shell in response to particular needs by adding or removing foam layers. Thus a single device may be used on  
10 abdomens of varying thickness, enhancing flexibility of application. Furthermore, the rigidity created by the induced gas and foam apron allows for hand insertion and withdrawal without the aid of an assistant or requiring the surgeon to use the other hand. Additionally, the external valve created by the inclusion of a foam shell is enhanced by the pressure of the induced gas passing up between the double walled tube and acting to force  
15 the opposing faces of film together outside the patients abdominal cavity.

Preferably, the sealing means further incorporates a distal valve for insertion into the body cavity.

20 Ideally, the distal valve includes a mechanical seal.

The invention will now be described more particularly with reference to the accompanying drawings, which show, by way of example only, various embodiments of a surgical device in accordance with the invention, in which:-

25

Fig. 1 is a top view of a surgical device in accordance with the invention;

Fig. 2 is a sectional view of the surgical device of Fig. 1 in the direction of the  
arrows A-A;

30

Fig. 3 is a sectional view similar to that shown in Fig. 2 showing the device in an inoperative position with a surgeon's hand approaching;

Fig. 4 is a sectional view as shown in Figs. 2 and 3 showing the device in an operating position with the surgeons hand in place;

5 Fig. 5 is a plan view of and alternative surgical device in accordance with the invention;

Fig. 6 is a front view of the surgical device of Fig. 5; and

10 Fig. 7 is an end view of the surgical device of Figs. 5 and 6.

Referring to the drawings, and initially to Figs. 1 to 4, there is illustrated a surgical device according to the invention, indicated generally by the reference numeral 1. The surgical device 1 is formed for use in minimally invasive surgery of the type using an inflated body cavity indicated generally by the reference numeral 2. The cavity 2 is accessible to a  
15 surgeon through an access port, defined by the device 1, surrounding an incision in a patient's abdominal wall 3.

In more detail, the device 1 has a body cavity engagement means provided by an anchor  
20 ring 5 for insertion into the incision to locate the device 1 in position. The device 1 is held in position on the patient's skin out side the body by a fixing means provided in this case by an adhesive web 6. The ring 5 and web 6 ensure that the device 1 is securely fixed in position and surround the incision. It will be noted that the web may be replaced by any functional equivalent to secure the device in position.

25

The web 6 has an associated connector ring 7 for receiving additional seals to prevent loss of pressure from the cavity 2. The connector ring 7 may also be used for holding or guiding medical instruments into position over or in the incision.

30 The device 1 has a sealing means, provided in this embodiment of the invention, by a saline filled toroid cell 8 connected between the anchor ring 5 and the web 6. The cell 8 is formed to prevent substantial leakage of gas from the body cavity 2 on inflation when in an

inoperative position see Figs. 2 and 3. The cell 8 is also formed to mould to a substantial portion of a surgeon's hand or surgical instrument when in an operating position (see Fig. 4). The cell 8 is also formed to allow for the removal of operative tissue when in an operating position with or without pneumoperitoneum established.

5

It will be noted that the cell may be filled with any suitable material and represents a significant improvement over prior art devices, which are inflated with air. The use of a liquid such as a sealed saline bladder improves hygiene around the wound and responds more quickly to a movement by a surgeon's hand. Additionally the invention overcomes  
10 problems associated with inflatable bladders, which will leak air if under inflated or be overly restrictive to movement if over inflated.

It will further be noted that the sealing means is described as a toroid or donut shaped cell, but that it could be equally provided as a lip shaped or elliptical cell tapering slightly at  
15 either end.

In use, an incision is made in the abdominal wall 3 and the anchor ring 5 passed through the incision into the cavity 2. The anchor ring 5 is moved when in the cavity 2 such that the ring 5 surrounds the incision. The web 6 is then attached to the patients skin to fix the  
20 device 1 in position with the cell 8 being connected between the web 6 and the ring 5 and engaging the portions of the abdominal wall 3 exposed by the incision. The cell 8 seal the incision and the abdominal cavity 2 may be inflated as required by the surgeon to an inoperative position Fig.2. The surgeon can gain access to the cavity 2 losing a minimum  
25 of gas pressure by passing a hand or instrument through the center of the toroid or donut shaped cell 8. When the hand or instrument is in the operating position (Fig. 4) the cell moulds to the hand or instrument to prevent loss of pressure.

Referring now to Figs. 5 to 7 there is illustrated a further surgical device in accordance with the invention indicated generally by the reference numeral 20, in which parts similar  
30 to those identified with reference to Figs. 1 to 4 are identified by the same reference numerals generally. In this embodiment the sealing means is in two sections. A foam shell 28 is in this case formed in two parts to envelop the incision site. It will be understood that

the foam shell may equally be provided as a single part, divided or split along an axis. The parts of the shell 28 are movable relatively to allow a surgeon access to the body cavity and can be biased together to seal the cavity 2 when not in use. A sleeve 30 connected to the web 6 covers the shell 28 and passes into the cavity 2 and is terminated in the cavity 2  
5 by a distal valve 31 having a mechanical seal 32. It will also be understood that the web 6 may equally be provided by an anchoring ring.

In use, the parts of the foam shell 28 are separated as before by the surgeon's hand or instrument and the foam moulds the shape of the inserted object to prevent loss of pressure.  
10 The inserted object then travels through the sleeve 30 to the distal valve 31 inside the cavity 2 and opens the mechanical seal 32. When the task has been completed the inserted object is removed and the mechanical seal 32 being so biased closes. The pressure in the cavity 2 is such during procedures of this type to close the sleeve 30 along its length as the object is removed and a final seal is provided by the foam shell 28 decompressing when  
15 the object has been removed.

The use of a foam shell has a number of advantages over known systems. For example, trauma at the incision is minimised as shock associated with downward pressure when inserting the surgeon's hand is largely absorbed by the foam. Tenting is eliminated as the  
20 foam shell reduces the volume of gas in the proximal end of the sleeve. The foam may also be used to absorb liquids such as blood in a hygienic manner and may reduce the effect of blood and body fluids on the anchoring ring. Furthermore it is envisaged that the lifting action of the foam may be used to retract tissue or for creating additional anchoring forces or between the distal valve and the abdominal wall. The cell may also be formed in  
25 any suitable manner to allow for the removal of operative tissue during the course of an operation whether or not pneumoperitoneum has been established.

It will be noted that the sleeve and valve may incorporate means for preventing the sleeve returning through the incision accidentally. These means may include but are not limited  
30 to an angled flap or flaps on the distal valve, tensioning means in the sleeve such as weld lines or a physical connection to a body part including the abdominal wall.



It will be understood that the foam shell may also be provided as a single block, defining a passageway therein, to allow communication between the exterior and the cavity.

It will of course be understood that the invention is not limited to the specific details  
5 described herein, which are given by way of example only, and that various modifications  
and alterations are possible within the scope of the invention as defined in the appended  
claims.

CLAIMS:

1. A surgical device for use in minimally invasive surgery of the type using an inflated body cavity accessible to a surgeon through an access port, defined by the device,  
5 surrounding an incision in a patients body, the device having: -
- body cavity engagement means for insertion into the incision to locate the device in position;
- 10 fixing means for attaching the device to a patients skin; and
- sealing means connected between the body cavity engagement means and the fixing means, the sealing means being formed to prevent substantial leakage of gas from the body cavity on inflation when in an inoperative position and formed to  
15 mould to a substantial portion of a surgeon's hand or surgical instrument on insertion in an operating position.
2. A surgical device as claimed in Claim 1, in which the body cavity engagement means is provided by an anchor ring formed for insertion into the incision.
- 20
3. A surgical device as claimed in Claim 1 or Claim 2, in which the fixing means is provided by an adhesive web or fixing ring.
4. A surgical device as claimed in any one of the preceding claims, in which the fixing  
25 means has an associated connector ring for receiving additional seals or medical instruments.
5. A surgical device as claimed in any one of the preceding claims, in which the sealing  
30 means is provided by a toroid cell formed to engage the incision between the fixing means and the body cavity engagement means.

6. A surgical device as claimed in Claim 5, in which the cell forms a bladder through which the surgeon may access the body cavity, the bladder being filled with a viscous or semi-viscous liquid.
- 5 7. A surgical device as claimed in Claim 6, in which the bladder is filled with saline, gel or foam.
8. A surgical device as claimed in Claim 1, in which the sealing means incorporates a foam shell formed for covering the incision.
- 10 9. A surgical device a claimed in Claim 8, in which the foam shell is formed in two parts, or as a single part partially divided along one axis, the parts being movable relatively to allow a surgeon access to the body cavity.
- 15 10. A surgical device as claimed in Claim 8 or Claim 9, in which the foam shell is formed by a plurality of individually disengageable layers, so that the surgeon can adjust the height of the foam shell in response to particular needs by adding or removing foam layers whereby a single device may be used on abdomens of varying thickness, enhancing flexibility of application.
- 20 11. A surgical device as claimed in Claim 10, in which the rigidity created by the induced gas and foam apron allows for hand insertion and withdrawal without the aid of an assistant or requiring the surgeon to use the other hand.
- 25 12. A surgical device as claimed in Claim 10 or Claim 11, in which the external valve created by the inclusion of a foam shell is enhanced by the pressure of the induced gas passing up between the double walled tube and acting to force the opposing faces of film together outside the patients abdominal cavity.
- 30 13. A surgical device as claimed in any one of the preceding claims in which the sealing means further incorporates a distal valve for insertion into the body cavity.

14. A surgical device as claimed in Claim 13, in which the distal valve includes a mechanical seal.

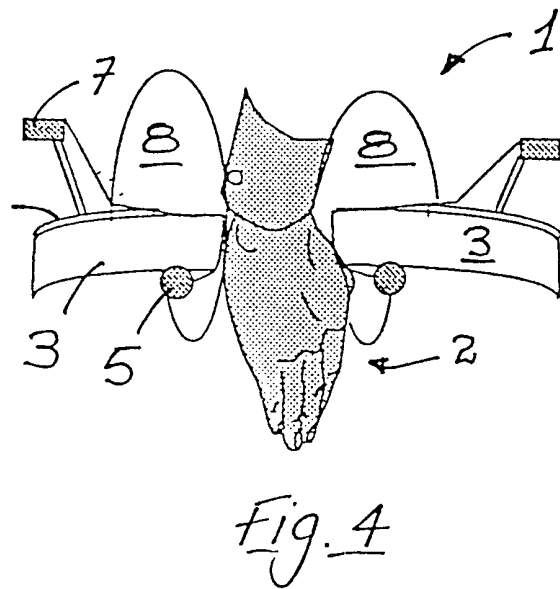
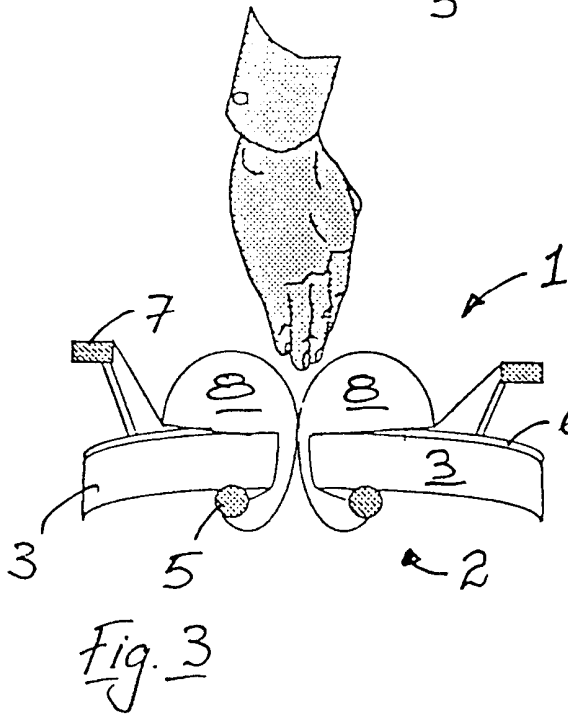
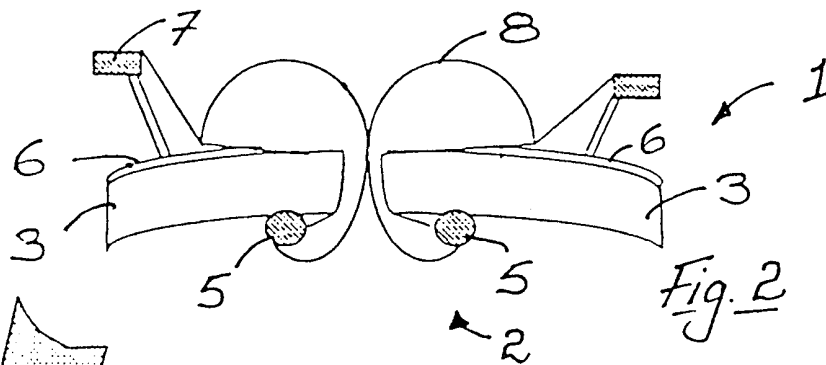
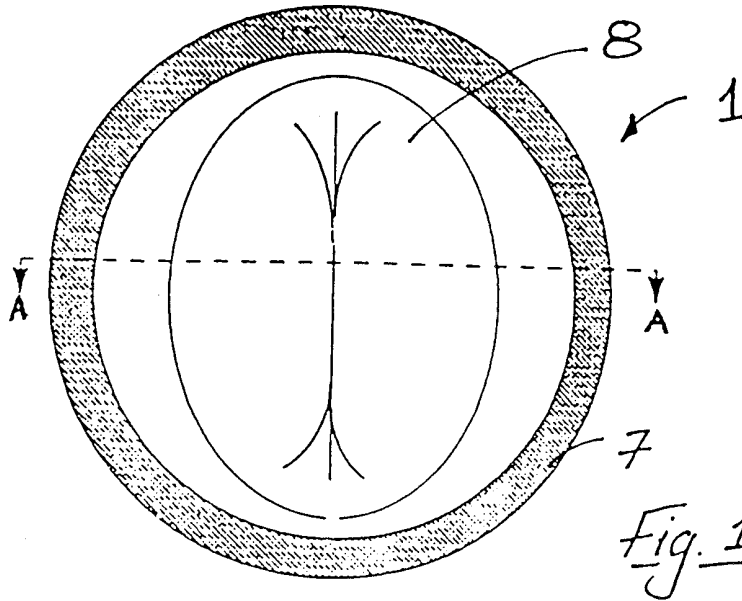

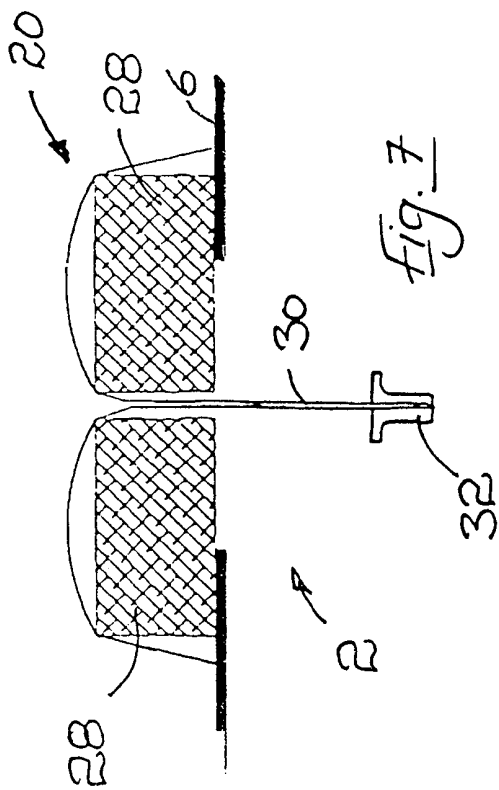
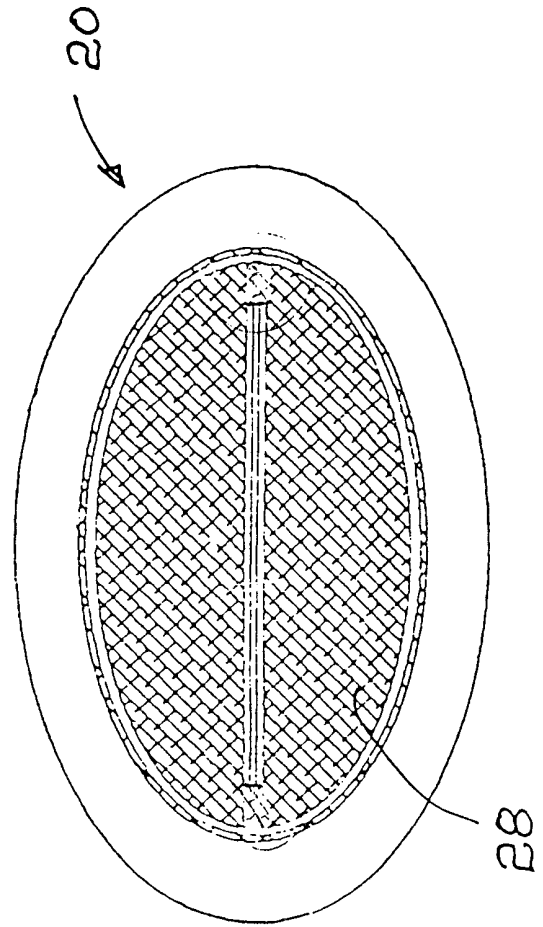
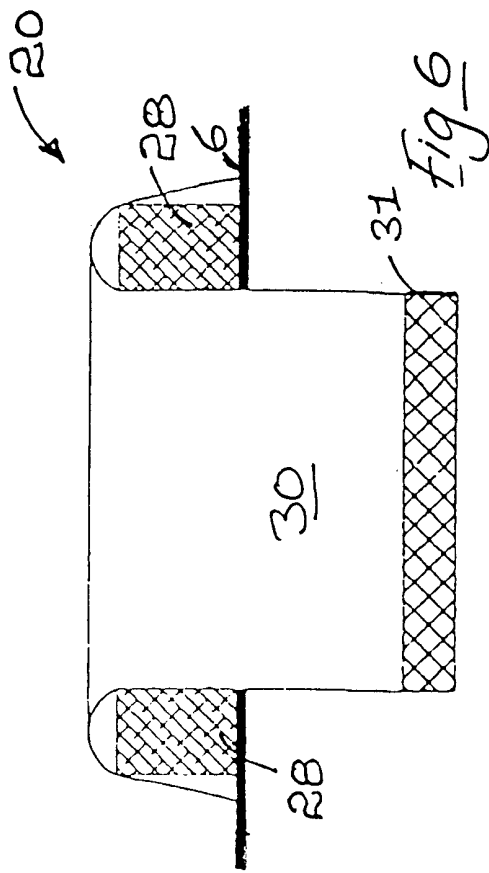

# INTERNATIONAL SEARCH REPORT

International Application No

PCT/IE 00/00034

**A. CLASSIFICATION OF SUBJECT MATTER**  
IPC 7 A61B17/34

According to International Patent Classification (IPC) or to both national classification and IPC

**B. FIELDS SEARCHED**

Minimum documentation searched (classification system followed by classification symbols)  
IPC 7 A61B

Documentation searched other than minimum documentation to the extent that such documents are included in the fields searched

Electronic data base consulted during the international search (name of data base and, where practical, search terms used)

EPO-Internal

**C. DOCUMENTS CONSIDERED TO BE RELEVANT**

Category °	Citation of document, with indication, where appropriate, of the relevant passages	Relevant to claim No.
X	US 5 366 478 A (CANDADAI RAMESH S ET AL) 22 November 1994 (1994-11-22) the whole document ---	1-3,5
X	GB 2 275 420 A (GAUNT DAVID RAMON ;GLICKMAN SCOTT (GB)) 31 August 1994 (1994-08-31) page 10, line 16 - line 21 ---	1,7,8
X	US 5 634 937 A (MOLLENAUER KENNETH H ET AL) 3 June 1997 (1997-06-03) abstract; claim 1; figure 17 ---	1,5-7
X	US 5 636 645 A (OU HONZEN) 10 June 1997 (1997-06-10) column 5, line 38 -column 9, line 6; figures 4-10 --- -/--	1,3,6,7

Further documents are listed in the continuation of box C.

Patent family members are listed in annex.

° Special categories of cited documents :

"A" document defining the general state of the art which is not considered to be of particular relevance

"E" earlier document but published on or after the international filing date

"L" document which may throw doubts on priority claim(s) or which is cited to establish the publication date of another citation or other special reason (as specified)

"O" document referring to an oral disclosure, use, exhibition or other means

"P" document published prior to the international filing date but later than the priority date claimed

"T" later document published after the international filing date or priority date and not in conflict with the application but cited to understand the principle or theory underlying the invention

"X" document of particular relevance; the claimed invention cannot be considered novel or cannot be considered to involve an inventive step when the document is taken alone

"Y" document of particular relevance; the claimed invention cannot be considered to involve an inventive step when the document is combined with one or more other such documents, such combination being obvious to a person skilled in the art.

"&" document member of the same patent family

Date of the actual completion of the international search

25 July 2000

Date of mailing of the international search report

04/08/2000

Name and mailing address of the ISA

European Patent Office, P.B. 5818 Patentlaan 2  
NL - 2280 HV Rijswijk  
Tel. (+31-70) 340-2040, Tx. 31 651 epo nl,  
Fax: (+31-70) 340-3016

Authorized officer

Hansen, S

# INTERNATIONAL SEARCH REPORT

International Application No

PCT/IE 00/00034

**C.(Continuation) DOCUMENTS CONSIDERED TO BE RELEVANT**

Category	Citation of document, with indication, where appropriate, of the relevant passages	Relevant to claim No.
X	US 5 514 133 A (STEIN H DAVID ET AL) 7 May 1996 (1996-05-07) the whole document ---	1,4
X	US 5 803 921 A (BONADIO FRANK) 8 September 1998 (1998-09-08) abstract; figures 1,9,23 ---	1
A	US 5 524 644 A (CROOK BERWYN M) 11 June 1996 (1996-06-11) abstract; figures 3-6 ---	1
A	US 5 741 298 A (MACLEOD CATHEL) 21 April 1998 (1998-04-21) abstract; figure 2 -----	1



# INTERNATIONAL SEARCH REPORT

Information on patent family members

International Application No

PCT/IE 00/00034

Patent document cited in search report		Publication date	Patent family member(s)	Publication date
US 5366478	A	22-11-1994	NONE	
GB 2275420	A	31-08-1994	NONE	
US 5634937	A	03-06-1997	WO 9636283 A US 5964781 A	21-11-1996 12-10-1999
US 5636645	A	10-06-1997	NONE	
US 5514133	A	07-05-1996	NONE	
US 5803921	A	08-09-1998	IE 940150 A IE 940613 A IE 950055 A AT 164303 T AU 695770 B AU 1717395 A BR 9506817 A CA 2183064 A CN 1144471 A CZ 9602404 A DE 69501880 D DE 69501880 T EP 0744922 A EP 0807416 A ES 2115365 T FI 963226 A HU 76016 A, B WO 9522289 A JP 9509079 T NO 963421 A NZ 279907 A PL 315939 A RU 2137453 C ZA 9501378 A	04-10-1995 04-10-1995 07-08-1996 15-04-1998 20-08-1998 04-09-1995 09-09-1997 24-08-1995 05-03-1997 16-04-1997 30-04-1998 23-07-1998 04-12-1996 19-11-1997 16-06-1998 17-10-1996 30-06-1997 24-08-1995 16-09-1997 14-10-1996 26-06-1998 09-12-1996 20-09-1999 24-10-1995
US 5524644	A	11-06-1996	NONE	
US 5741298	A	21-04-1998	US 5947922 A	07-09-1999