



(19) **United States**

(12) **Patent Application Publication**
Shuros et al.

(10) **Pub. No.: US 2007/0282376 A1**

(43) **Pub. Date: Dec. 6, 2007**

(54) **METHOD AND APPARATUS FOR NEURAL STIMULATION VIA THE LYMPHATIC SYSTEM**

Publication Classification

(51) **Int. Cl.**
A61N 1/32 (2006.01)
(52) **U.S. Cl.** 607/2
(57) **ABSTRACT**

(76) Inventors: **Allan C. Shuros**, St. Paul, MN (US); **Randy Westlund**, River Falls, WI (US); **Anthony V. Caparso**, St. Louis Park, MN (US)

Correspondence Address:
SCHWEGMAN, LUNDBERG & WOESSNER, P.A.
P.O. BOX 2938
MINNEAPOLIS, MN 55402

An implantable neural stimulation system includes an implantable medical device having a neural stimulation circuit and at least one implantable lead configured to allow one or more stimulation electrodes to be placed in one or more lymphatic vessels of a patient, such as the patient's thoracic duct and/or vessels branching from the thoracic duct. Neural stimulation pulses are delivered from the implantable medical device to one or more target regions adjacent to the thoracic duct or the vessels branching from the thoracic duct through the one or more stimulation electrodes.

(21) Appl. No.: **11/422,421**
(22) Filed: **Jun. 6, 2006**

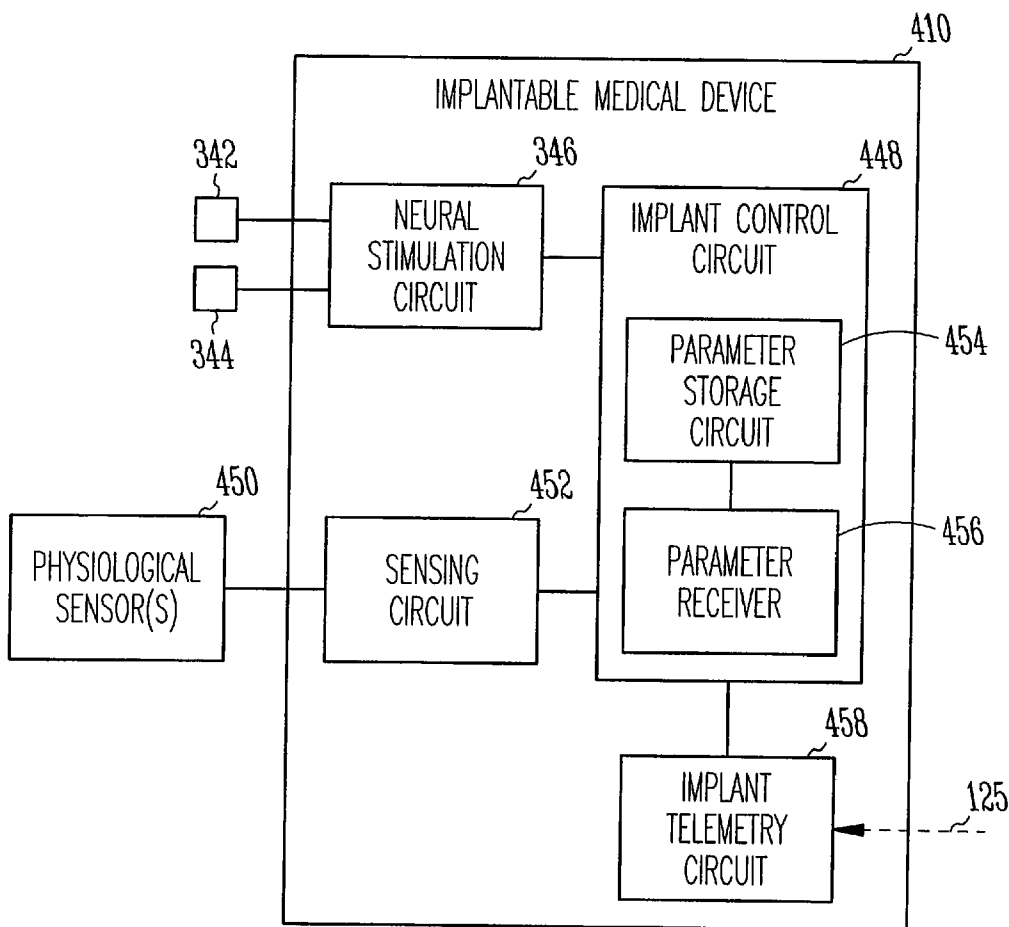

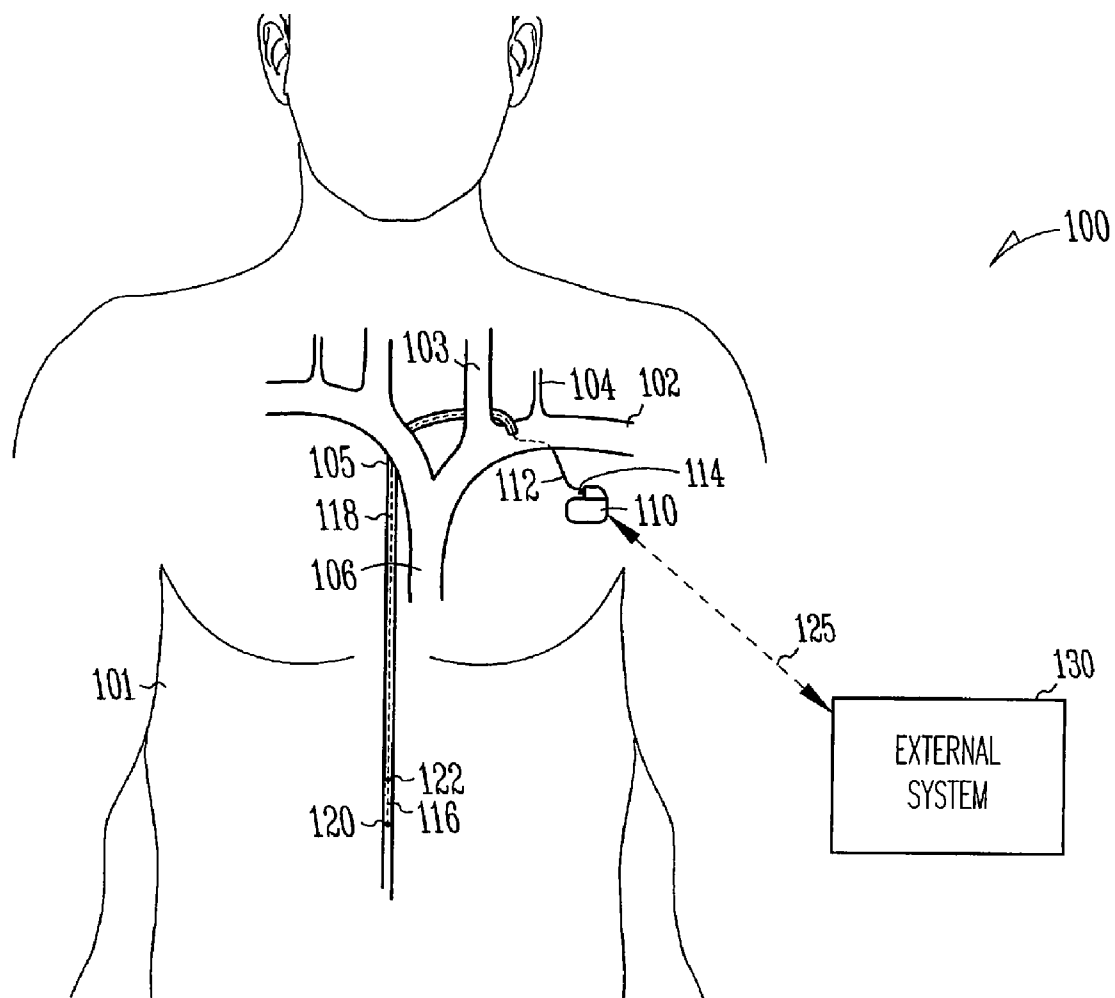

Fig. 1

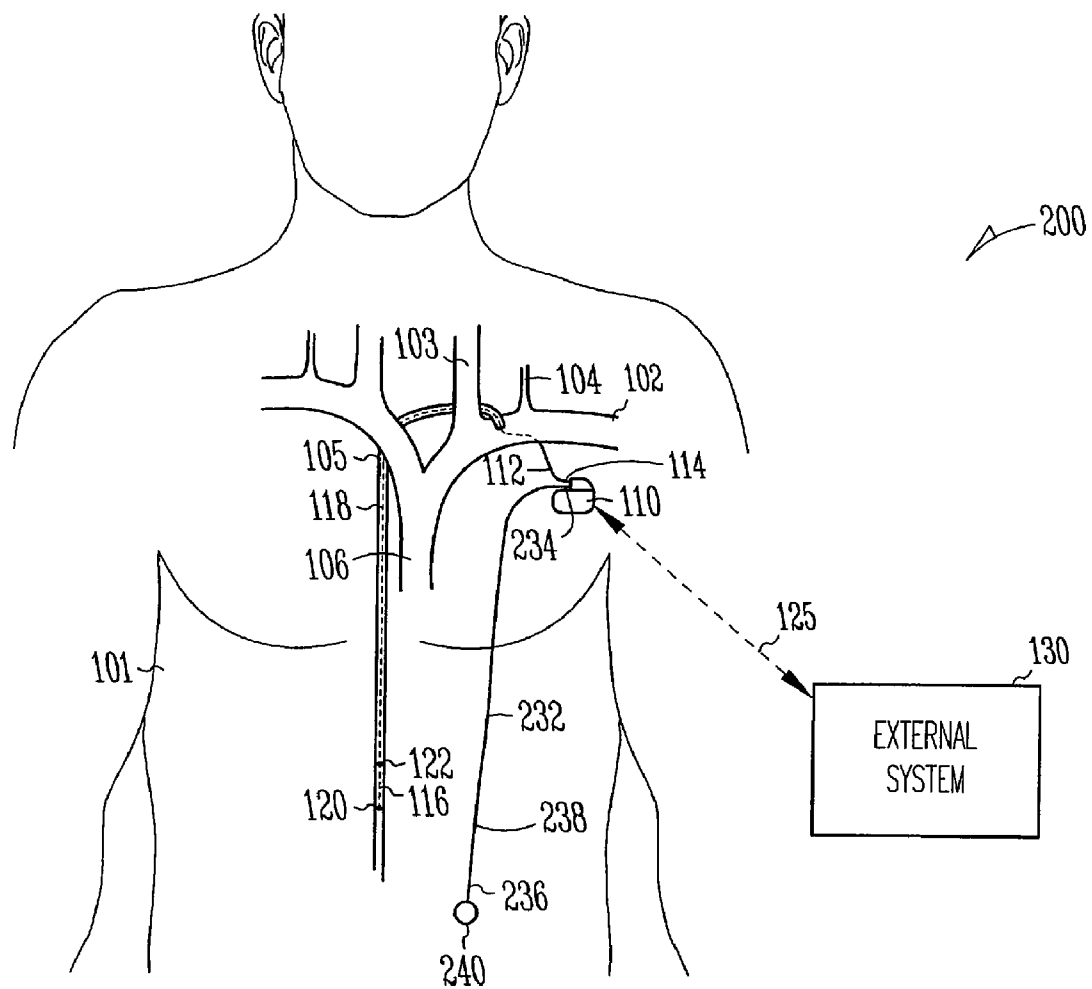

Fig. 2

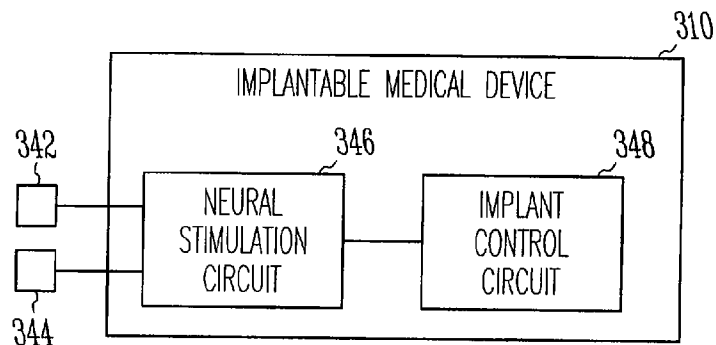

Fig. 3

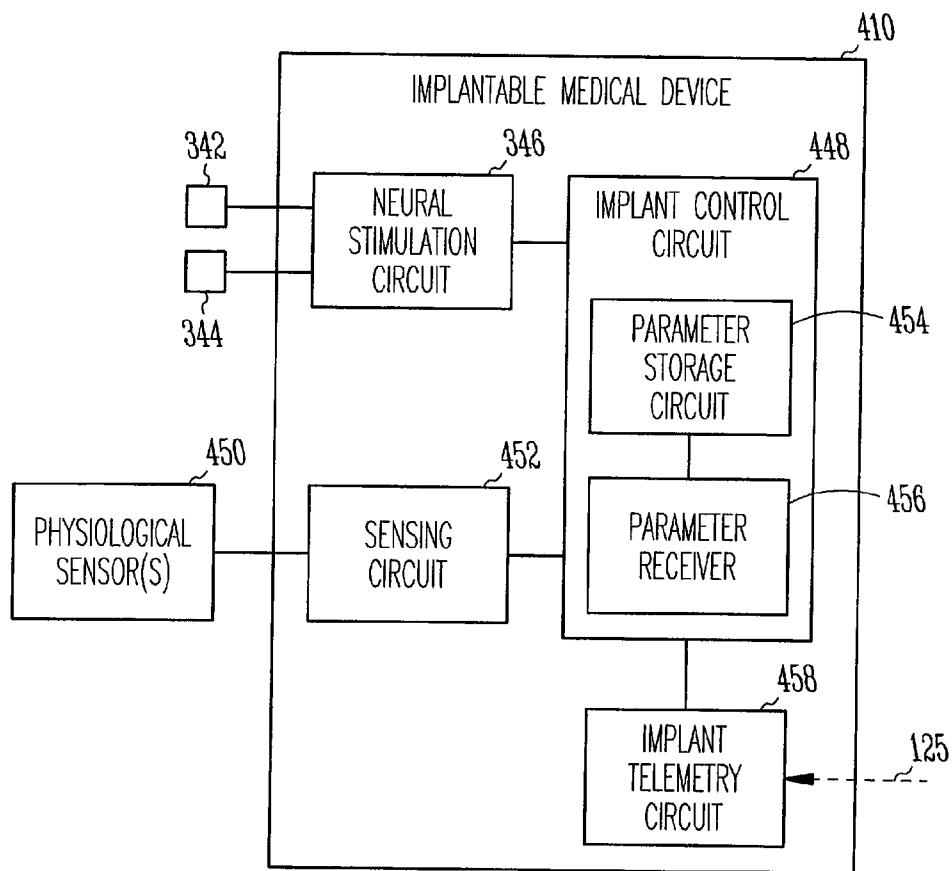

Fig. 4

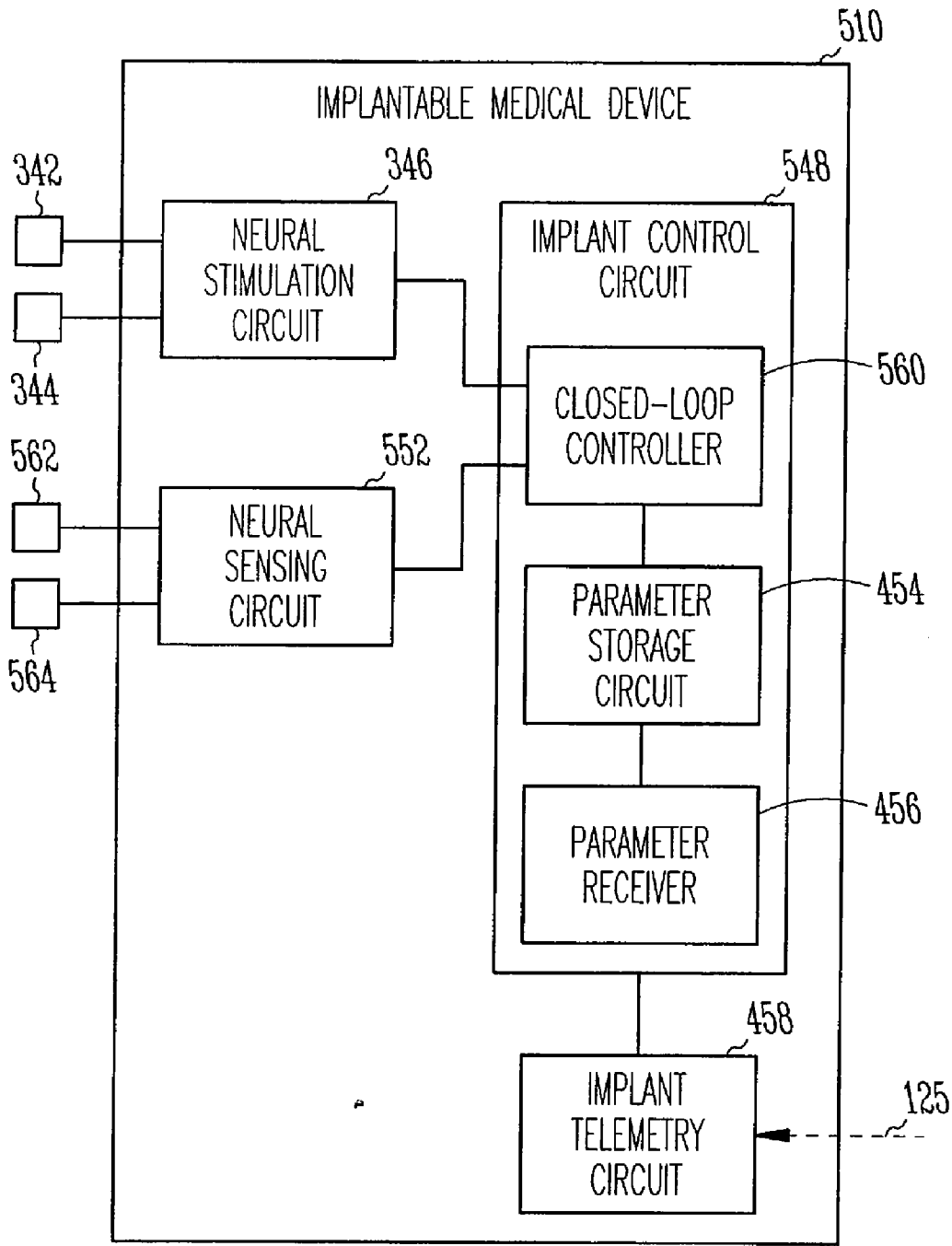

Fig. 5

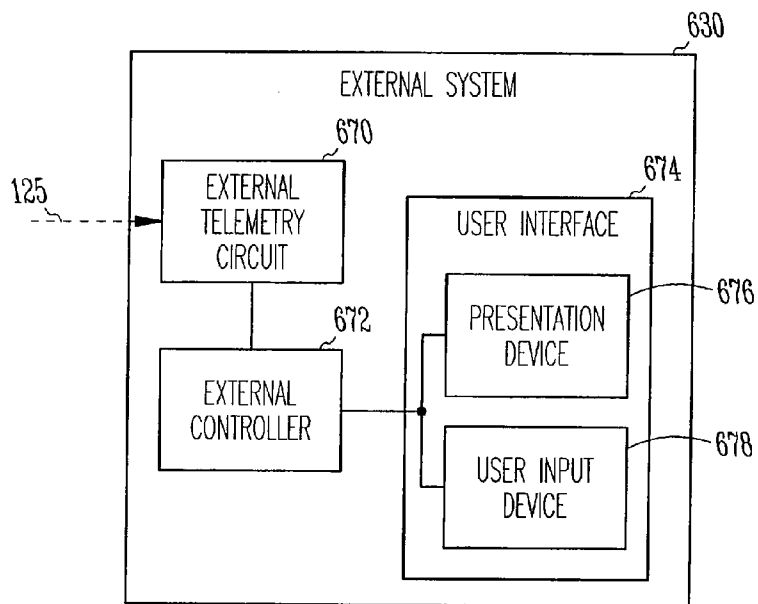

Fig. 6

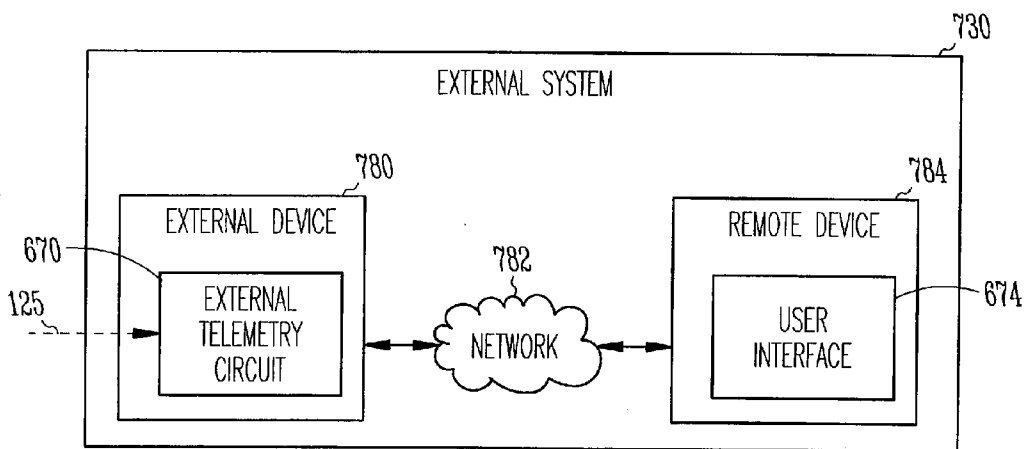
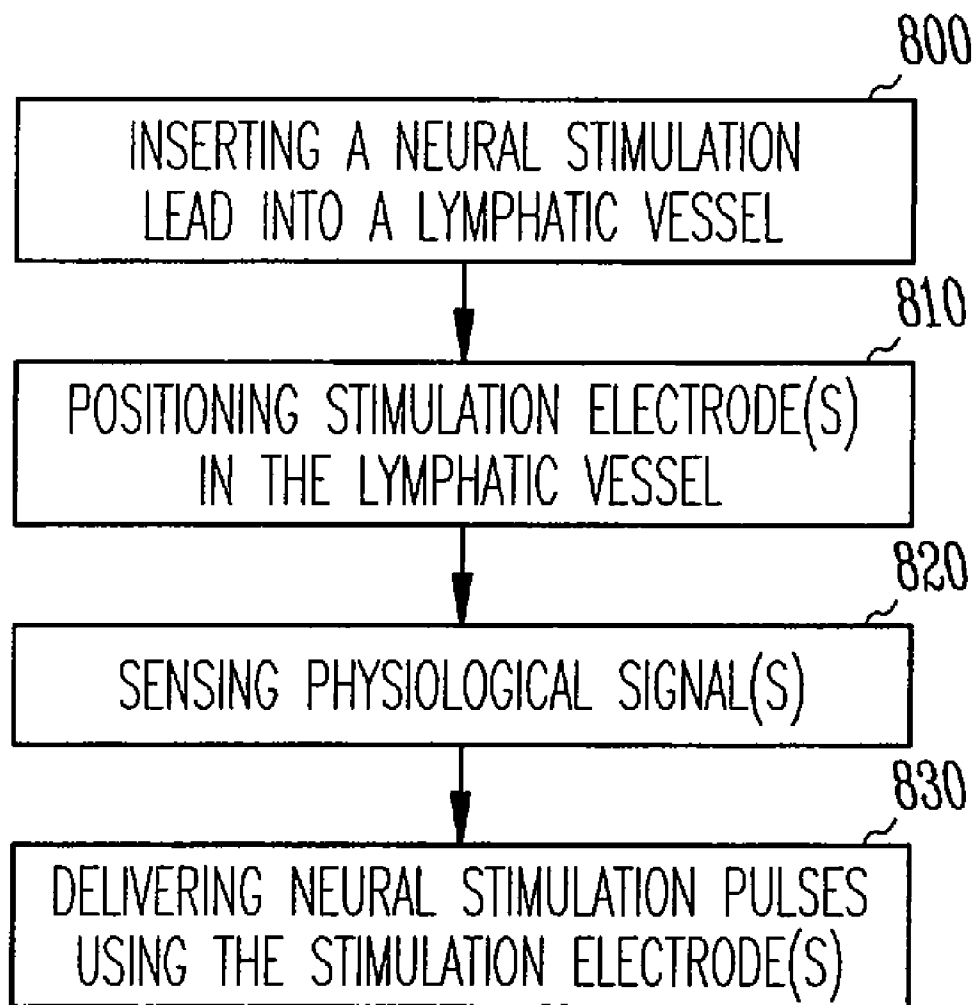

Fig. 7

*Fig. 8*

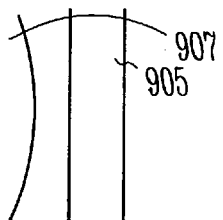

Fig. 9

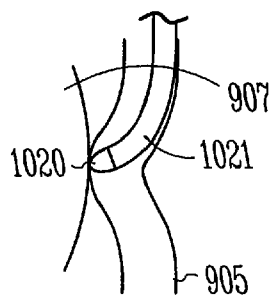

Fig. 10

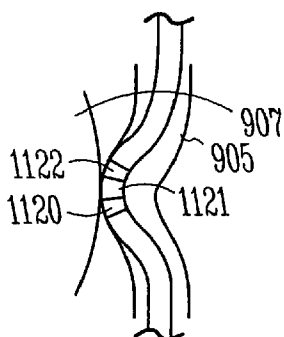

Fig. 11

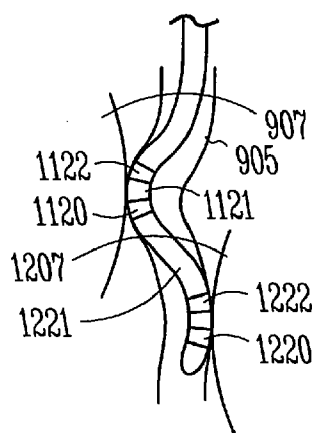

Fig. 12

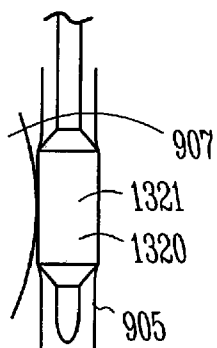

Fig. 13

METHOD AND APPARATUS FOR NEURAL STIMULATION VIA THE LYMPHATIC SYSTEM

CROSS-REFERENCE TO RELATED APPLICATIONS

[0001] This application is related to co-pending, commonly assigned, U.S. patent application Ser. No. _____, entitled "METHOD AND APPARATUS FOR LYMPHATIC SYSTEM PACING AND SENSING," filed on even date herewith (Attorney Docket No. 279.A69US1), U.S. patent application Ser. No. _____, entitled "METHOD AND APPARATUS FOR GASTROINTESTINAL STIMULATION VIA THE LYMPHATIC SYSTEM," filed on even date herewith _____ (Attorney Docket No. 279.A66US1), U.S. patent application Ser. No. _____, entitled "METHOD AND DEVICE FOR LYMPHATIC SYSTEM MONITORING," filed even date herewith (Attorney Docket No. 279.A05US1), and U.S. patent application Ser. No. _____, entitled "METHOD AND DEVICE FOR ENDO-LYMPHATIC STIMULATION," filed on even date herewith (Attorney Docket No. 279.A04US1), which are hereby incorporated herein by reference in their entirety.

TECHNICAL FIELD

[0002] This document relates generally to medical devices and particularly to an implantable system that delivers neural stimulation via one or more lymphatic vessels.

BACKGROUND

[0003] Neural stimulation has been applied to treat various pathological conditions. Controlled delivery of electrical stimulation pulses to a nerve generates, modulates, or inhibits activities of that nerve, thereby restoring the functions of that nerve and/or regulating the functions of the tissue or organ innervated by that nerve. One specific example of neural stimulation is to regulate cardiac functions and hemodynamic performance by delivering electrical stimulation pulses to portions of the autonomic nervous system. The heart is innervated with sympathetic and parasympathetic nerves. Activities in these nerves, including artificially applied electrical stimuli, modulate cardiac functions and hemodynamic performance. Direct electrical stimulation of parasympathetic nerves can activate the baroreflex, inducing a reduction of sympathetic nerve activity and reducing blood pressure by decreasing vascular resistance. Sympathetic inhibition, as well as parasympathetic activation, has been associated with reduced arrhythmia vulnerability following a myocardial infarction, presumably by increasing collateral perfusion of the acutely ischemic myocardium and decreasing myocardial damage. Modulation of the sympathetic and parasympathetic nervous system with neural stimulation has been shown to have positive clinical benefits, such as protecting the myocardium from further remodeling and predisposition to fatal arrhythmias following a myocardial infarction.

[0004] Implantable medical systems are used to deliver neural stimulation. A typical implantable neural stimulation system includes an implantable neural stimulator that delivers electrical stimulation pulses through a plurality of stimulation electrodes. Depending on the location of the nerve to be stimulated, the stimulation electrodes may be incorporated onto the implantable neural stimulator and/or con-

nected to the implantable neural stimulator using one or more implantable leads. In practice, the desirable stimulation sites may not be in a location with anatomical structure allowing for easy implantation of the implantable neural stimulator or easy access by the lead(s). The degree of risk associated with the implantation procedure increases with the degree of invasiveness. Therefore, given a desirable stimulation site, there is a need to minimize the invasiveness of implanting a system that delivers neural stimulation pulses to that stimulation site.

SUMMARY

[0005] An implantable neural stimulation system includes an implantable medical device having a neural stimulation circuit and at least one implantable lead configured to allow one or more stimulation electrodes to be placed in one or more lymphatic vessels of a patient, such as the patient's thoracic duct and/or vessels branching from the thoracic duct. Neural stimulation pulses are delivered from the implantable medical device to one or more target regions adjacent to the thoracic duct or the vessels branching from the thoracic duct through the one or more stimulation electrodes.

[0006] In one embodiment, a neural stimulation system includes an electrode assembly and an implantable medical device. The electrode assembly includes an electrode base configured to be implanted into a lymphatic vessel and a stimulation electrode on the electrode base. The electrode base is configured to cause a portion of the lymphatic vessel to substantially alter its natural path to contact a target region to which neural stimulation pulses are delivered and maintain the contact between the portion of the lymphatic vessel and the target region after the implantation of the electrode assembly. The implantable medical device includes a neural stimulation circuit that delivers the neural stimulation pulses through the stimulation electrode.

[0007] In one embodiment, a method for delivering neural stimulation is provided. Neural stimulation pulses are delivered from an implantable medical device to at least one stimulation electrode placed in a lymphatic vessel.

[0008] This Summary is an overview of some of the teachings of the present application and not intended to be an exclusive or exhaustive treatment of the present subject matter. Further details about the present subject matter are found in the detailed description and appended claims. Other aspects of the invention will be apparent to persons skilled in the art upon reading and understanding the following detailed description and viewing the drawings that form a part thereof. The scope of the present invention is defined by the appended claims and their legal equivalents.

BRIEF DESCRIPTION OF THE DRAWINGS

[0009] The drawings illustrate generally, by way of example, various embodiments discussed in the present document. The drawings are for illustrative purposes only and may not be to scale.

[0010] FIG. 1 is an illustration of an embodiment of a neural stimulation system and portions of an environment in which the neural stimulation system is used.

[0011] FIG. 2 is an illustration of another embodiment of the neural stimulation system and portions of the environment in which the neural stimulation system is used.

[0012] FIG. 3 is a block diagram illustrating an embodiment of an implantable medical device of the neural stimulation system.

[0013] FIG. 4 is a block diagram illustrating a specific embodiment of the implantable medical device.

[0014] FIG. 5 is a block diagram illustrating another specific embodiment of the implantable medical device.

[0015] FIG. 6 is a block diagram illustrating an embodiment of an external system of the neural stimulation system.

[0016] FIG. 7 is a block diagram illustrating an embodiment of the external system being a patient management system.

[0017] FIG. 8 is a flow chart illustrating a method for delivering neural stimulation via the thoracic duct.

[0018] FIG. 9 is an illustration of a lymphatic vessel and a target region for neural stimulation.

[0019] FIG. 10 is an illustration of an embodiment of an electrode assembly for placement in the lymphatic vessel to allow for the neural stimulation.

[0020] FIG. 11 is an illustration of an embodiment of another electrode assembly for placement in the lymphatic vessel to allow for the neural stimulation.

[0021] FIG. 12 is an illustration of an embodiment of another electrode assembly for placement in the lymphatic vessel to allow for the neural stimulation.

[0022] FIG. 13 is an illustration of an embodiment of another electrode assembly for placement in the lymphatic vessel to allow for the neural stimulation.

DETAILED DESCRIPTION

[0023] In the following detailed description, reference is made to the accompanying drawings which form a part hereof, and in which is shown by way of illustration specific embodiments in which the invention may be practiced. These embodiments are described in sufficient detail to enable those skilled in the art to practice the invention, and it is to be understood that the embodiments may be combined, or that other embodiments may be utilized and that structural, logical and electrical changes may be made without departing from the spirit and scope of the present invention. References to “an”, “one”, or “various” embodiments in this disclosure are not necessarily to the same embodiment, and such references contemplate more than one embodiment. The following detailed description provides examples, and the scope of the present invention is defined by the appended claims and their legal equivalents.

[0024] This document discusses an implantable neural stimulation system including an implantable medical device delivering neural stimulation through at least one stimulation delivery device placed in a lymphatic vessel, such as the thoracic duct, of a patient. In one embodiment, the implantable neural stimulation system includes a transluminal lead configured for insertion into a portion of the lymphatic vessel to allow one or more stimulation electrodes to be placed in the lymphatic vessel. The implantable medical device includes a neural stimulation circuit that generates electrical pulses. The electrical pulses are delivered to one or more target regions adjacent to the lymphatic vessel through the one or more stimulation electrodes placed in the lymphatic vessel. While the thoracic duct is specifically discussed in this document as an example of such a lymphatic vessel, neural stimulation pulses are delivered through any one or more lymphatic vessels, including, but not limited to, the thoracic duct, lymphatic vessels branching from the

thoracic duct, the right lymphatic duct, and lymphatic vessels branching from the right lymphatic duct.

[0025] While electrical stimulation is specifically discussed in this document as an example, the present subject matter includes neurostimulation using any form of energy that is capable of stimulating one or more components of the nervous system via the lymphatic vessel such as the thoracic duct. In various embodiments, the stimulation delivery device placed in the lymphatic vessel generates or receives neural stimuli, which are then delivered to one or more neural stimulation sites via the lymphatic vessel. The neural stimuli are in one or more forms of energy that are capable of eliciting a neural response, such as electrical, magnetic, electromagnetic, thermal, and/or acoustic (including ultrasonic) energy.

[0026] FIG. 1 is an illustration of an embodiment of a neural stimulation system 100 and portions of an environment in which system 100 is used. System 100 includes an implantable medical device 110, a lead 112, an external system 130, and a telemetry link 125 providing for communication between implantable medical device 110 and external system 130.

[0027] System 100 delivers neural stimulation pulses through at least one electrode placed in a thoracic duct 105, which is part of the lymphatic system of a patient's body 101. The lymphatic system includes lymph tissue, nodes, and vessels. Interstitial fluid is absorbed from tissue, filtered through lymph nodes, and empties into lymphatic vessels. FIG. 1 illustrates portions of thoracic duct 105, a subclavian vein 102, a left external jugular vein 104, a left internal jugular vein 103, and a superior vena cava 106. Thoracic duct 105 connects to the venous system at the juncture of subclavian vein 102 and a left internal jugular vein 103. The fluid (lymph) from the lower body flows up to thoracic duct 105 and empties into subclavian vein 102 from thoracic duct 105. Thoracic duct 105 is located in the posterior mediastinal area of body 101, adjacent to the heart and various portions of the nervous system including portions of the vagus, sympathetic, and phrenic nerves. Electrical stimulation of such nerves is delivered by using one or more stimulation electrodes placed within thoracic duct 105. Thoracic duct 105 is used as a conduit for advancing the one or more stimulation electrodes to a location from which electrical stimulation can be delivered to a target region of the nervous system of body 101. This approach to the process of electrode placement for neural stimulation has the potential of reducing the invasiveness of implantation procedure under many circumstances.

[0028] Implantable medical device 110 generates neural stimulation pulses that are electrical pulses and delivers the neural stimulation pulses through lead 112. In one embodiment, implantable medical device 110 also senses neural activities using at least lead 112. In various embodiments, implantable medical device 110 is capable of sensing other physiological signals and/or delivering therapies in addition to the neural stimulation. Examples of such additional therapies include cardiac pacing therapy, cardioversion/defibrillation therapy, cardiac resynchronization therapy (CRT), cardiac remodeling control therapy (RCT), drug therapy, cell therapy, and gene therapy. In various embodiments, implantable medical device 110 delivers the neural stimulation in coordination with one or more such additional therapies. In one embodiment, in addition to lead 112,

system 100 includes one or more endocardial and/or epicardial leads for delivering pacing and/or defibrillation pulses to the heart.

[0029] Lead 112 is an implantable neural stimulation lead including a proximal end 114, a distal end 116, and an elongate lead body 118 between proximal end 114 and distal end 116. Proximal end 114 is coupled to implantable medical device 110. Distal end 116 includes at least one stimulation electrode for delivering the neural stimulation pulses to a target region of the nervous system of body 101. In one embodiment, as illustrated in FIG. 1, distal end 116 includes stimulation electrodes 120 and 122. In various other embodiments, distal end 116 includes one stimulation electrode or three or more stimulation electrodes. In one embodiment, a reference electrode is incorporated onto implantable medical device 110. In a specific embodiment, implantable medical device 110 includes a hermetically sealed conductive housing that functions as the reference electrode. Neural stimulation pulses are delivered using (i) two stimulation electrodes in distal end 116 (electrodes 120 or 122), or (ii) a stimulation electrode (electrode 120 or 122) in distal end 116 and the reference electrode on implantable medical device 110. In various embodiments, one or more of the stimulation electrodes are also used for sensing one or more neural signals. The distal portion of elongate lead body 118 (a substantial portion of elongate lead body 118 coupled to distal end 116) is configured for placement in subclavian vein 102 and thoracic duct 105, such that distal end 116 is placed in thoracic duct 105. During the implantation of lead 112, distal end 116 is inserted into subclavian vein 102 through an incision, advanced in subclavian vein 102 toward thoracic duct 105, inserted into thoracic duct 105 from subclavian vein 102, and advanced in thoracic duct 105 until a predetermined location in thoracic duct 105 is reached. In one embodiment, the position of distal end 116 is adjusted by delivering test neural stimulation pulses and detecting evoked neural signals and/or other physiological responses. In one embodiment, lead 112 includes a fixation mechanism configured to stabilize distal end 116 in the determined position in thoracic duct 105. Implantable medical device 110 is connected to proximal end 114 and is subcutaneously implanted. One example of method and apparatus for accessing the lymphatic system is discussed in U.S. patent application Ser. No., _____, entitled "METHOD AND APPARATUS FOR LYMPHATIC SYSTEM PACING AND SENSING," filed on even date herewith (Attorney Docket No. 279.A69 μ l), assigned to Cardiac Pacemakers, Inc., which is incorporated herein by reference in its entirety. Specific examples of electrode configurations and placement are also discussed in detail below, with reference to FIGS. 9-12.

[0030] In one embodiment, lead 112 is configured such that distal end 116 can be further advanced into a lymphatic vessel branching from thoracic duct 105, such as the gastric branch, so that the stimulation electrode can be placed in close proximity of a desirable target region. After the distal end 116 is inserted into thoracic duct 105, it is advanced to the junction of thoracic duct 105 and the branching lymphatic vessel and inserted to the branching lymphatic vessel. While the placement of at least one stimulation electrode in the thoracic duct is specifically discussed as an example of providing for access to a target region, the present subject matter generally includes introducing one or more stimulus delivery devices such as one or more stimulation electrodes

to a stimulation site via a lymphatic vessel. In various embodiments, neural stimulation pulses are delivered through one or more stimulation electrodes placed in the lymphatic vessel and/or one or more stimulation electrodes placed in a structure that is accessible through the lymphatic vessel, including another lymphatic vessel branching from the lymphatic vessel.

[0031] In one embodiment, system 100 includes two or more leads each including one or more stimulation electrodes arranged to be placed in thoracic duct 105. In another embodiment, a lead includes a plurality of electrodes arranged for delivering independently controllable neural stimulation pulses to two or more target regions.

[0032] External system 130 communicates with implantable medical device 110 and provides for access to implantable medical device 110 by a physician or other caregiver. In one embodiment, external system 130 includes a programmer. In another embodiment, external system 130 is a patient management system including an external device communicating with implantable medical device 110 via telemetry link 125, a remote device in a relatively distant location, and a telecommunication network linking the external device and the remote device. The patient management system allows access to implantable medical device 110 from a remote location, for purposes such as monitoring patient status and adjusting therapies. In one embodiment, telemetry link 125 is an inductive telemetry link. In another embodiment, telemetry link 125 is a far-field radio-frequency (RF) telemetry link. Telemetry link 125 provides for data transmission from implantable medical device 110 to external system 130. This includes, for example, transmitting real-time physiological data acquired by implantable medical device 110, extracting physiological data acquired by and stored in implantable medical device 110, extracting patient history data such as occurrences of predetermined types of pathological events and therapy deliveries recorded in implantable medical device 110, and/or extracting data indicating an operational status of implantable medical device 110 (e.g., battery status and lead impedance). Telemetry link 125 also provides for data transmission from external system 130 to implantable medical device 110. This includes, for example, programming implantable medical device 110 to acquire physiological data, programming implantable medical device 110 to perform at least one self-diagnostic test (such as for a device operational status), and/or programming implantable medical device 110 to deliver one or more therapies and/or to adjust the delivery of one or more therapies.

[0033] FIG. 2 is an illustration of an embodiment of a neural stimulation system 200 and portions of the environment in which system 200 is used. System 200 includes the components of neural stimulation system 100 and an additional lead. That is, neural stimulation system 200 includes implantable medical device 110, leads 112 and 232, external system 130, and telemetry link 125.

[0034] Lead 232 is an implantable neural stimulation lead including a proximal end 234, a distal end 236, and an elongate lead body 238 between proximal end 234 and distal end 236. Proximal end 234 is coupled to implantable medical device 110. Distal end 236 includes at least one electrode. In one embodiment, as illustrated in FIG. 2, lead 232 includes an electrode 240 at distal end 236. In another embodiment, lead 232 includes a plurality of stimulation electrodes. In one embodiment, lead 232 is configured for

subcutaneous placement, external to thoracic duct **105**. In one embodiment, electrode **240** is used as a reference electrode.

[0035] Lead **232** expands the range of target regions to which neural stimulation pulses can be delivered from implantable medical device **110**. In various embodiments, neural stimulation pulses are delivered through any pair of electrodes of system **200** including (i) two stimulation electrodes in distal end **116** (electrodes **120** and **122**), (ii) a stimulation electrode in distal end **116** (electrode **120** or **122**) and electrode **240** (as the reference electrode), or (iii) a stimulation electrode in distal end **116** (electrode **120** or **122**) and the reference electrode on implantable medical device **110**. In one embodiment, distal ends **116** and **236** are positioned such as a target structure for the neural stimulation is approximately between a stimulation electrode in distal end **116** (electrode **120** or **122**) and a reference electrode (electrode **240** or the reference electrode on implantable medical device **110**). For example, the target structure is a portion of the spinal cord of body **101**.

[0036] FIG. **3** is a block diagram illustrating an embodiment of an implantable medical device **310**, which is a specific embodiment of implantable medical device **110**. Implantable medical device **310** includes a neural stimulation circuit **346** and an implant control circuit **348**. Neural stimulation circuit **346** delivers neural stimulation pulses to a pair of stimulation electrodes **342** and **344**, through which the neural stimulation pulses are delivered to a target region in the nervous system. At least one of stimulation electrodes **342** and **344** is placed in thoracic duct **105**. Implant control circuit **348** controls the delivery of the neural stimulation pulses from neural stimulation circuit **346**.

[0037] In one embodiment, stimulation electrodes **342** and **344** are both in thoracic duct **105** and adjacent to the target region, such as electrodes **120** and **122**. In another embodiment, stimulation electrode **342** is in thoracic duct **105** and adjacent to the target region, such as electrode **120** or **122**, and stimulation electrode **344** is external to thoracic duct **105**, such as electrode **240** or a reference electrode on implantable medical device **310**. In one embodiment, the target region is approximately between stimulation electrodes **342** and **344**.

[0038] In various embodiments, the target region includes one or more components of the nervous system that are adjacent to the thoracic duct in the posterior mediastinal region or abdominal region. Examples of the target region include the sympathetic nerves, the parasympathetic nerves (including the vagus nerve), the phrenic nerve, the spinal cord, the brain stem, the renal nerves, and the baroreceptors in the carotid artery and aorta. In one embodiment, cardiac functions are regulated by applying neural stimulation including one or more of sympathetic excitation, sympathetic inhibition, parasympathetic excitation, and parasympathetic inhibition. One example of a system capable of providing excitatory stimulation and inhibitory stimulation to both sympathetic nerves and parasympathetic nerves is discussed in U.S. patent application Ser. No. 11/124,791, entitled "METHOD AND APPARATUS FOR CONTROLLING AUTONOMIC BALANCE USING NEURAL STIMULATION," filed on May 9, 2005, assigned to Cardiac Pacemakers, Inc., which is incorporated herein by reference in its entirety.

[0039] For illustration purposes, FIG. **3** shows the pair of stimulation electrodes **342** and **344**. In various embodi-

ments, neural stimulation circuit **346** delivers neural stimulation pulses through one or more pairs of stimulation electrodes selected from a plurality of stimulation electrodes. In one embodiment, neural stimulation circuit **346** includes two or more stimulation output channels each delivering neural stimulation pulses through a pair of stimulation electrodes. In another embodiment, an electrode array with a plurality of stimulation electrodes is placed in the thoracic duct, and one or more stimulation electrodes are selected for delivering neural stimulation pulses by testing the physiological effect of stimulation associated with each stimulation electrode.

[0040] FIG. **4** is a block diagram illustrating an embodiment of an implantable medical device **410**, which is another specific embodiment of implantable medical device **110**. Implantable medical device **410** includes neural stimulation circuit **346**, a sensing circuit **452**, an implant control circuit **448**, and an implant telemetry circuit **458**. One or more physiological sensors **450** are housed within implantable medical device **410**, incorporated onto implantable medical device **410**, and/or connected to implantable medical device **410** using a lead.

[0041] Physiological sensor(s) **450** sense one or more physiological signals indicative of neural function and/or physiological functions regulated by the components of the nervous system to be stimulated. Sensing circuit **452** processes the one or more physiological signals and produces signals indicative of a need to start, stop, or adjust the neural stimulation. Examples of such physiological signals include signals indicative of heart rate, heart rate variability (HRV), and blood pressure. In one embodiment, physiological sensor(s) **450** include one or both of stimulation electrodes **342** and **344**, which are utilized as sensing electrodes.

[0042] Implant control circuit **448** is a specific embodiment of implant control circuit **348** and controls the delivery of the neural stimulation pulses from neural stimulation circuit **346** using a plurality of stimulation parameters. Implant control circuit **448** includes a parameter storage circuit **454** and a parameter receiver **456**. Parameter storage circuit **454** stores values of the plurality of stimulation parameters. Examples of such stimulation parameters include pulse amplitude, pulse width, and pulse frequency (or inter-pulse interval). The values of the plurality of stimulation parameters are adjustable. Parameter receiver **456** receives values of the plurality of stimulation parameters and updates parameter storage circuit **454** with the received values. In one embodiment, implant control circuit **448** controls the delivery of the neural stimulation pulses from neural stimulation circuit **346** using one or more physiological signals sensed by physiological sensor(s) **450**. In various embodiments, each sensed physiological signal is used as one or more of a triggering signal to start or stop the neural stimulation, a safety assurance signal to start, stop, or adjust the intensity of the neural stimulation, and a feedback signal to provide closed-loop neural stimulation.

[0043] Implant telemetry circuit **458** transmits and receives data via telemetry link **125**. In one embodiment, the values of the plurality of stimulation parameters are externally programmable, and the programmed values are received from external system **130** through telemetry link **125**.

[0044] FIG. **5** is a block diagram illustrating an implantable medical device **510**, which is a specific embodiment of implantable medical device **410**. Implantable medical device

510 includes neural stimulation circuit **346**, a neural sensing circuit **552**, an implant control circuit **548**, and implant telemetry circuit **458**.

[0045] Neural sensing circuit **552** is a specific embodiment of sensing circuit **452** and processes a neural signal sensed using neural sensing electrodes **562** and **564**, which represent a specific embodiment of physiological sensor(s) **450**. In one embodiment, neural sensing circuit **552** processes two or more neural signals sensed using additional neural sensing electrodes. In one embodiment, the neural signal is sensed from the same site to which the neural stimulation pulses are delivered, and stimulation electrodes **342** and **344** are used as neural sensing electrodes **562** and **564**. In other words, stimulation electrodes **342** and **344** and neural sensing electrodes **562** and **564** are physically the same pair of electrodes. In another embodiment, the neural signal is sensed from a site different from the site to which the neural stimulation pulses are delivered. At least one of stimulation electrodes **342** and **344** is not used as any of neural sensing electrodes **562** and **564**.

[0046] Implant control circuit **548** is a specific embodiment of implant control circuit **448** and includes a closed-loop controller **560**, parameter storage circuit **454**, and parameter receiver **456**. Implant control circuit **548** controls the delivery of the neural stimulation pulses from neural stimulation circuit **346** using a plurality of stimulation parameters and the sensed and processed neural signal. Closed-loop controller **560** controls the delivery of the neural stimulation pulses using the sensed and processed neural signal as an input for feedback control. Examples of closed-loop neural stimulation are discussed in U.S. patent application Ser. No. 11/280,940, entitled "SYSTEM AND METHOD FOR CLOSED-LOOP NEURAL STIMULATION," filed on Nov. 16, 2005, assigned to Cardiac Pacing-makers, Inc., which is incorporated herein by reference in its entirety.

[0047] FIG. 6 is a block diagram illustrating an embodiment of an external system **630**, which is a specific embodiment of external system **130**. External system **630** includes an external telemetry circuit **670**, an external controller **672**, and a user interface **674**. External telemetry circuit **670** transmits and receives data via telemetry link **125**. External controller **672** controls the operation of external system **630**. User interface **674** allows a user such as a physician or other caregiver to communicate with implantable medical device **110** through external system **630**. User interface **674** includes a presentation device **676** and a user input device **678**. User input device **678** allows for the programming of the values of the plurality of stimulation parameters. In one embodiment, presentation device **676** and user input device **678** are integrated or partially integrated to include an interactive screen allowing for programming of implantable medical device **110**.

[0048] In one embodiment, external system **630** includes a programmer. In another embodiment, external system **630** includes a patient management system as discussed below with reference to FIG. 7.

[0049] FIG. 7 is a block diagram illustrating an embodiment of an external system **730**, which is a specific embodiment of external system **630**. As illustrated in FIG. 7, external system **730** is a patient management system including an external device **780**, a telecommunication network **782**, and a remote device **784**. External device **780** is placed within the vicinity of implantable medical device **110** and includes

external telemetry system **670** to communicate with the implantable medical device via telemetry link **125**. Remote device **784** is in a remote location and communicates with external device **780** through network **782**. Remote device **784** includes user interface **674** to allow the physician or other caregiver to monitor and treat a patient from a distant location and/or allowing access to various treatment resources from the remote location.

[0050] FIG. 8 is a flow chart illustrating a method for delivering neural stimulation via the thoracic duct. In one embodiment, the method is performed using system **100** or system **200**, including the various embodiments of their components discussed above.

[0051] A neural stimulation lead is inserted into a lymphatic vessel of a patient at **800**. In one embodiment, this lymphatic vessel is the thoracic duct. The neural stimulation lead is an implantable transluminal lead having a proximal end configured for connection to an implantable medical device and a distal end including one or more stimulation electrodes. To insert the neural stimulation lead into the thoracic duct such that neural stimulation pulses can be delivered through the stimulation electrode(s), an opening is made on the subclavian vein, upstream from the junction of the subclavian vein and the ostium of the thoracic duct. The distal end of the neural stimulation lead is inserted into the subclavian vein through the opening and advanced toward the junction of the subclavian vein and the ostium of the thoracic duct downstream. Then, the neural stimulation lead is guided into the thoracic duct and advanced in the thoracic duct until the distal end reaches a region determined by the target to which the neural stimulation pulses are delivered. Examples of the target region include any nerve of other components of the nervous system in the mediastinal or abdominal region, adjacent to the thoracic duct, such as sympathetic nerves, parasympathetic nerves including the vagus nerve, the phrenic nerve, renal nerves, the spinal cord, the brain stem, and baroreceptors in the carotid artery and aorta. In one embodiment, to further approach a desirable target region, the distal end of the neural stimulation lead is guided into a lymphatic vessel branching from the thoracic duct.

[0052] The stimulation electrode(s) of the neural stimulation lead are positioned in the lymphatic vessel, such as the thoracic duct or the lymphatic vessel branching from the thoracic duct, at **810**. In one embodiment, after the distal end of the neural stimulation lead reaches the region determined by the target, test neural stimulation pulses are delivered. The distal end is moved in the thoracic duct or the lymphatic vessel branching from the thoracic duct until it reaches a position identified by detecting satisfactory responses to the stimulation, such as evoked neural signals and/or other anticipated physiological effects. The distal end with the stimulation electrode(s) is then stabilized in that position. In another embodiment, the neural stimulation lead includes a plurality of stimulation electrodes. After the neural stimulation lead is inserted, test neural stimulation pulses are delivered to different stimulation electrodes or different combinations of the stimulation electrodes, one at a time. A stimulation electrode or a combination of stimulation electrodes is identified for an intended therapy based on the responses to the stimulation, such as evoked neural signals and/or other anticipated physiological effects.

[0053] One or more physiological signals are sensed at **820**. In one embodiment, at least one physiological signal is

sensed to indicate a need to start, stop, or adjust the delivery of the neural stimulation. In another embodiment, at least one physiological signal is sensed for monitoring, diagnostic, and/or therapeutic purposes other than the neural stimulation. In one embodiment, one or more neural signals are sensed. In a specific embodiment, a neural signal is sensed from the nerve to which the neural stimulation is delivered. In another embodiment, one or more signals each indicative of a physiological function regulated by the stimulated nerve are sensed.

[0054] Neural stimulation pulses are delivered using the stimulation electrode(s) positioned in the lymphatic vessel, such as the thoracic duct or the lymphatic vessel branching from the thoracic duct, at **830**. In one embodiment, the neural stimulation pulses are delivered through two stimulation electrodes positioned in the thoracic duct or the lymphatic vessel branching from the thoracic duct. In another embodiment, the neural stimulation pulses are delivered using a stimulation electrode positioned in the thoracic duct or the lymphatic vessel branching from the thoracic duct and another stimulation electrode positioned in a location in the body external to the lymphatic vessels. In a specific embodiment, the neural stimulation pulses are delivered to a portion of the nervous system approximately between a pair of stimulation electrodes. The delivery of the neural stimulation pulses is controlled using a plurality of stimulation parameters. Examples of the stimulation parameters include pulse amplitude, pulse width, and pulse frequency (or inter-pulse interval). These stimulation parameters are adjustable. In one embodiment, a user such as a physician or other caregiver programs one or more values of the plurality of stimulation parameters. In one embodiment, the delivery of the neural stimulation pulses are also controlled using the one or more physiological signals, including the one or more neural signals.

[0055] The neural stimulation pulses are delivered via the thoracic duct or the lymphatic vessel branching from the thoracic duct to treat one or more clinical conditions each associated with a physiological function regulated by a nerve or other component of the nervous system that is adjacent the thoracic duct or the lymphatic vessel branching from the thoracic duct. Examples of such clinical conditions include respiratory disorders, abnormal blood pressure, cardiac arrhythmias, myocardial infarction or ischemic insult (angina), heart failure, epilepsy, depression, renal disorders, pain, migraine, obesity, movement disorders, and incontinence. Specific examples of the treatment include (i) treatment of hypertension by baroreceptor stimulation, (ii) treatment of heart failure by sympathetic inhibition or vagal excitation; (iii) control of post-myocardial infarction remodeling by sympathetic inhibition or vagal excitation, (iv) mitigation of chronic pain by neural activation or blocking, (v) treatment of vascular pain including refractory angina and peripheral vascular diseases (PVD) by spinal cord stimulation, (vi) treatment of rachidian pain including failed back surgery syndrome (FBSS), degenerative low back leg pain (LBLEP), nerve root lesions, incomplete spine lesions and spinal stenosis by spinal cord stimulation, (vii) treatment of type 1 or type 2 chronic regional pain syndrome (CRPS) by spinal cord stimulation, and (viii) treatment of perineal pain and urological diseases by spinal cord stimulation, and restoration of lower extremity motor functions such as standing and walking after spinal cord injury by ventral spinal cord stimulation.

[0056] FIGS. 9-13 illustrate, by way of example, various embodiments of an electrode assembly for placement in the lymphatic vessel to allow for the neural stimulation. The electrode assembly includes one or more electrode bases. One or more stimulation electrodes are incorporated onto and/or integrated with each of the one or more electrode bases. In one embodiment, the one or more electrode bases each are formed as portion of a lead such as lead **112**. In one specific embodiment, an electrode base is formed at distal end **116** of lead **112**, and stimulation electrodes **120** and **122** are on that electrode base. In another specific embodiment, one or more electrode bases are formed in elongate lead body **118** of lead **112**. In another embodiment, electrode bases are formed at distal end **116** and elongate lead body **118** of lead **112** to provide for delivery of the neural stimulation pulses to multiple target regions.

[0057] FIG. 9 is an illustration of a lymphatic vessel **905** and a target region **907** in their natural state. Target region **907** is a region in the nervous system to which the neural stimulation pulses are delivered. As illustrated in FIG. 9, lymphatic vessel **905** and target region **907** are not in direct contact, or not constantly in direct contact, with each other in their natural state. Electrode assemblies illustrated in FIGS. 10-13 each cause and maintain a substantially constant and direct contact between lymphatic vessel **905** and target region **907** by substantially altering the natural path of lymphatic vessel **905**. Such a substantially constant and direct contact allows for a reliable delivery of neural stimulation pulses from one or more electrodes in lymphatic vessel **905** to target region **907**. In various embodiments, lymphatic vessel **905** represents one of the thoracic duct, a vessel branching from the thoracic duct, or any lymphatic vessel suitable for placement of the one or more electrodes for the delivery of the neural stimulation pulses.

[0058] FIG. 10 is an illustration of an embodiment of an electrode assembly including an electrode base **1021** configured to be implanted in lymphatic vessel **905** and a stimulation electrode **1020** on electrode base **1021**. Electrode base **1021** has an elongate shape and includes a bias configured to cause a portion of lymphatic vessel **905** to substantially alter its natural path to contact target region **907**. The bias also allows electrode **1020** to be in contact with the inner wall of lymphatic vessel **905** for delivering the neural stimulation pulses to target region **907**. Electrode base **1021** has a stiffness allowing for stabilizing the position of stimulation electrode **1020** in lymphatic vessel **905** and maintaining the contact between the portion of lymphatic vessel **905** and target region **907** after implantation. In one embodiment, electrode base **1021** is in a helical form. In one embodiment, electrode base **1021** includes an elongate body having shape memory characteristics such that it returns to its preformed shape after the implantation procedure during which a stylet or guide wire may be used. The shape memory characteristics are provided by using a shape memory polymer such as polyether polyurethane or a shape memory metal. In one embodiment, the electrode assembly is coupled to implantable medical device **110** via a lead such as lead **112**. In a specific embodiment, electrode base **1021** is formed at distal end **116** of lead **112**, with stimulation electrode **1020** being stimulation electrode **120**. In other specific embodiments, two or more stimulation electrodes are incorporated into electrode base **1021**.

[0059] FIG. 11 is an illustration of an embodiment of another electrode assembly including an electrode base **1121**

configured to be implanted in lymphatic vessel 905 and stimulation electrodes 1120 and 1122, both on electrode base 1121. Electrode base 1121 has an elongate shape and includes a bias configured to cause a portion of lymphatic vessel 905 to substantially alter its natural path to contact target region 907. The bias also allows electrodes 1120 and 1122 to be in contact with the inner wall of lymphatic vessel 905 for delivering the neural stimulation pulses to target region 907 using either or both of electrodes 1120 and 1122. Electrode base 1121 has the stiffness allowing for stabilizing the positions of stimulation electrodes 1120 and 1122 in lymphatic vessel 905 and maintaining the contact between the portion of lymphatic vessel 905 and target region 907 after implantation. In one embodiment, electrode base 1121 is in a helical form. In one embodiment, electrode base 1121 includes an elongate body having shape memory characteristics such that it returns to its preformed shape after the implantation procedure during which a stylet or guide wire may be used. The shape memory characteristics are provided by using a shape memory polymer such as polyether polyurethane or a shape memory metal. In one embodiment, the electrode assembly is coupled to implantable medical device 110 via a lead such as lead 112. In a specific embodiment, electrode base 1121 is formed at distal end 116 of lead 112, with stimulation electrodes 1120 and 1122 being stimulation electrodes 120 and 122. In other specific embodiments, one stimulation electrode, or three or more stimulation electrodes, are incorporated into electrode base 1121.

[0060] FIG. 12 is an illustration of an embodiment of another electrode assembly including an electrode base 1121 with stimulation electrodes 1120 and 1122 and another electrode base 1221 with stimulation electrodes 1220 and 1222. Electrode bases 1121 and 1221 are both configured to be implanted in lymphatic vessel 905. Electrode bases 1121 has the elongate shape and includes the bias configured to cause a portion of lymphatic vessel 905 to substantially alter its natural path to contact target region 907. The bias also allows electrodes 1120 and 1122 to be in contact with the inner wall of lymphatic vessel 905 for delivering neural stimulation pulses to target region 907 using either or both of electrodes 1120 and 1122. Electrode bases 1221 has an elongate shape and includes a bias configured to cause a portion of lymphatic vessel 905 to substantially alter its natural path to contact a target region 1207. The bias also allows electrodes 1220 and 1222 to be in contact with the inner wall of lymphatic vessel 905 for delivering neural stimulation pulses to target region 1207 using either or both of electrodes 1220 and 1222. Electrode bases 1121 and 1221 each have a stiffness allowing for stabilizing the positions of the stimulation electrodes in lymphatic vessel 905 and maintaining the contact between the portion of lymphatic vessel 905 and target region 907 after implantation. In one embodiment, electrode bases 1121 and 1221 are each in a helical form. In one embodiment, electrode bases 1121 and 1221 each include an elongate body having shape memory characteristics such that it returns to its preformed shape after the implantation procedure during which a stylet or guide wire may be used. The shape memory characteristics are provided by using a shape memory polymer such as polyether polyurethane or a shape memory metal. In one embodiment, the electrode assembly is coupled to implantable medical device 110 via a lead such as lead 112. In a specific embodiment, electrode base 1121 is formed at distal end 116 of lead 112, with stimulation electrodes 1120 and

1122 being stimulation electrodes 120 and 122, and electrode base 1221 is formed in elongate lead body 118 of lead 112. In other specific embodiments, one stimulation electrode, or three or more stimulation electrodes, are incorporated into each of electrode bases 1121 and 1221.

[0061] FIG. 13 is an illustration of an embodiment of another electrode assembly including an electrode base 1321 and a stimulation electrode 1320. Electrode base 1321 is expandable. After being expanded, electrode base 1321 causes a portion of lymphatic vessel 905 to substantially expand to contact target region 907. The expansion of electrode base 1321 also allows electrode 1320 to be in stable contact with the inner wall of lymphatic vessel 905 for delivering neural stimulation pulses to target region 907. In one embodiment, electrode base 1321 includes a stent that is expanded in the lymphatic vessel to maintain patency of the vessel. In one embodiment, stimulation electrode 1320 is incorporated into the stent. In another embodiment, the stent is made of metal and functions as stimulation electrode 1320. In another embodiment, stimulation electrode 1320 is integrated into the stent to be a portion of its structure. The stent also stabilize the position of stimulation electrode 1320 in lymphatic vessel 905 and prevents obstruction of the lymphatic flow. In one embodiment, the electrode assembly is coupled to implantable medical device 110 via a lead such as lead 112. In a specific embodiment, the stent is incorporated into distal end 116 of lead 112. In another embodiment, the stent is incorporated into elongate lead body 118 of lead 112. In another embodiment, two or more stents are incorporated into elongate lead body 118 and/or distal end 116 of lead 112.

[0062] It is to be understood that the above detailed description is intended to be illustrative, and not restrictive. Other embodiments will be apparent to those of skill in the art upon reading and understanding the above description. The scope of the invention should, therefore, be determined with reference to the appended claims, along with the full scope of equivalents to which such claims are entitled.

What is claimed is:

1. A system for delivering neural stimulation to a target region in a body having lymphatic vessels, the system comprising:

a first electrode assembly including a first electrode base configured to be implanted into one of the lymphatic vessels and a first stimulation electrode on the first electrode base, the first electrode base configured to cause a portion of the one of the lymphatic vessels to substantially alter its natural path to contact the target region and maintain the contact between the portion of the one of the lymphatic vessels and the target region after an implantation of the first electrode assembly; and

an implantable medical device including a neural stimulation circuit adapted to deliver neural stimulation pulses through the first stimulation electrode.

2. The system of claim 1, wherein the first electrode base comprises an elongate electrode base including one or more biases each configured to cause the portion of the one of the lymphatic vessels to substantially alter its natural path to contact the target region, the elongate electrode base having a stiffness allowing for maintaining the contact between the portion of the one of the lymphatic vessels and the target region after the implantation of the first electrode assembly.

3. The system of claim 1, wherein the first electrode base comprises an expandable electrode base configured to cause the portion of the one of the lymphatic vessels to substantially alter its natural path to contact the target region, after being expanded.

4. The system of claim 3, wherein the expandable electrode base comprises a stent, and the first electrode is incorporated into or integrated with the stent.

5. The system of claim 1, further comprising a first implantable lead having a first distal end, a first proximal end configured to be connected to the implantable medical device, and a first elongate lead body between the first distal end and the first proximal end, and wherein the first electrode assembly is incorporated into the first implantable lead.

6. The system of claim 5, wherein the first electrode assembly is incorporated into the first distal end.

7. The system of claim 5, wherein the first electrode assembly is incorporated into the first elongate lead body.

8. The system of claim 5, wherein the first electrode base further comprises a second stimulation electrode, and the neural stimulation circuit is adapted to deliver the neural stimulation pulses through the first stimulation electrode and the second stimulation electrode.

9. The system of claim 5, further comprising a second stimulation electrode configured to be placed in a location external to the lymphatic vessels, and wherein the neural stimulation circuit is adapted to deliver the neural stimulation pulses through the first stimulation electrode and the second stimulation electrode.

10. The system of claim 9, further comprising a second implantable lead configured to be subcutaneously implanted, the second implantable lead having a second distal end including the second stimulation electrode, a second proximal end configured to be connected to the implantable medical device, and a second elongate lead body between the distal end and the proximal end.

11. The system of claim 9, wherein the second stimulation electrode is incorporated onto the implantable medical device.

12. The system of claim 5, comprising a physiological sensor adapted to sense a physiological signal, and wherein the implantable medical device comprises:

a sensing circuit, coupled to the physiological sensor, to process the physiological signal; and

an implant control circuit adapted to control the delivery of the neural stimulation pulses using the physiological signal.

13. The system of claim 12, wherein the physiological sensor comprises a neural sensing electrode configured to sense a neural signal, the sensing circuit comprises a neural sensing circuit to process the neural signal, and the implant control circuit is adapted to control the delivery of the neural stimulation pulses using the processed neural signal.

14. The system of claim 13, wherein the neural sensing electrode is the first stimulation electrode.

15. The system of claim 13, wherein the implant control circuit comprises a closed-loop controller adapted to provide feedback control of the delivery of the neural stimulation pulses using the sensed neural signal as an input signal.

16. The system of claim 5, wherein the implantable medical device comprises an implant control circuit adapted

to control the delivery of the neural stimulation pulses using a plurality of stimulation parameters, the implant control circuit including:

a parameter storage circuit to store values of the plurality of stimulation parameters; and

a parameter receiver to receive one or more programmed values of the plurality of stimulation parameters and to update the parameter storage circuit with the received one or more programmed values of the plurality of stimulation parameters.

17. The system of claim 16, wherein the implantable medical device comprises an implant telemetry circuit to receive the one or more programmed values of the plurality of stimulation parameters.

18. The system of claim 17, further comprising an external system communicatively coupled to the implantable medical device, the external system including:

a user input device adapted to allow programming of the one or more programmed values of the parameters; and an external telemetry circuit to transmit the one or more programmed values of the plurality of stimulation parameters to the implantable medical device.

19. A method for delivering neural stimulation to a body having lymphatic vessels including a thoracic duct, the method comprising:

delivering neural stimulation pulses from an implantable medical device to at least a first stimulation electrode placed in one of the lymphatic vessels.

20. The method of claim 19, further comprising altering a natural path of the one of the lymphatic vessels to cause a portion of the one of the lymphatic vessels to contact a target region to which the neural stimulation are delivered using an electrode base configured to be implanted in the one of the lymphatic vessels, and wherein the first stimulation electrode is incorporated into or integrated with the electrode base.

21. The method of claim 19, wherein delivering the neural stimulation pulses comprises delivering the neural stimulation pulses through a stimulation electrode placed in the thoracic duct.

22. The method of claim 19, wherein delivering the neural stimulation pulses comprises delivering the neural stimulation pulses through a stimulation electrode placed in one of the vessels branching from the thoracic duct.

23. The method of claim 19, wherein delivering the neural stimulation pulses comprises delivering the neural stimulation pulses through the first stimulation electrode and a second stimulation electrode placed in the one of the lymphatic vessels.

24. The method of claim 19, wherein delivering the neural stimulation pulses comprises delivering the neural stimulation pulses through the first stimulation electrode and a second stimulation electrode placed in a location in the body external the lymphatic vessels.

25. The method of claim 19, further comprising: sensing one or more physiological signals; and controlling the delivery of the neural stimulation pulses using the one or more physiological signals.

26. The method of claim 25, wherein sensing the one or more physiological signals comprises sensing a neural signal using the first stimulation electrode, and controlling the delivery of the neural stimulation pulses comprises controlling the delivery of the neural stimulation pulses using the neural signal.

27. The method of claim **19**, further comprising:
controlling the delivery of the neural stimulation pulses
using a plurality of stimulation parameters;
receiving one or more values of the plurality of stimula-
tion parameters; and
storing the received one or more values of the plurality of
the stimulation parameters.

28. The method of claim **27**, further comprising program-
ming one or more values of the stimulation parameters
according to a target to which the neural stimulation pulses
are delivered, the target including one or more component of
a nervous system.

29. The method of claim **28**, wherein delivering the neural
stimulation pulses comprises delivering the neural stimula-
tion pulses to a parasympathetic nerve.

30. The method of claim **29**, wherein delivering the neural
stimulation pulses comprises delivering the neural stimula-
tion pulses to a vagus nerve.

31. The method of claim **28**, wherein delivering the neural
stimulation pulses comprises delivering the neural stimula-
tion pulses to a sympathetic nerve.

32. The method of claim **28**, wherein delivering the neural
stimulation pulses comprises delivering the neural stimula-
tion pulses to a spinal cord.

33. The method of claim **28**, wherein delivering the neural
stimulation pulses comprises delivering the neural stimula-
tion pulses to baroreceptors.

* * * * *