

(19) **DANMARK**

(10) **DK/EP 3454797 T3**



(12) **Oversættelse af
europæisk patentskrift**

Patent- og
Varemærkestyrelsen

-
- (51) Int.Cl.: **A 61 F 5/00 (2006.01)** **A 61 F 5/44 (2006.01)** **A 61 F 5/445 (2006.01)**
A 61 F 5/448 (2006.01) **A 61 F 13/00 (2006.01)** **A 61 F 13/02 (2006.01)**
A 61 F 5/443 (2006.01)
- (45) Oversættelsen bekendtgjort den: **2022-03-28**
- (80) Dato for Den Europæiske Patentmyndigheds bekendtgørelse om meddelelse af patentet: **2022-02-09**
- (86) Europæisk ansøgning nr.: **16867368.9**
- (86) Europæisk indleveringsdag: **2016-12-09**
- (87) Den europæiske ansøgnings publiceringsdag: **2019-03-20**
- (86) International ansøgning nr.: **US2016065787**
- (87) Internationalt publikationsnr.: **WO2017087993**
- (30) Prioritet: **2016-05-12 US 201662335208 P**
- (84) Designerede stater: **AL AT BE BG CH CY CZ DE DK EE ES FI FR GB GR HR HU IE IS IT LI LT LU LV MC MK MT NL NO PL PT RO RS SE SI SK SM TR**
- (73) Patenthaver: **Marlen Manufacturing And Development Co., 5150 Richmond Road, Bedford, OH 44146, USA**
- (72) Opfinder: **FENTON, Gary, H., 33475 N. Deer Creek Lane, Pepper Pike, OH 44124, USA**
- (74) Fuldmægtig i Danmark: **Plougmann Vingtoft A/S, Strandvejen 70, 2900 Hellerup, Danmark**
- (54) Benævnelse: **MONTERINGSANORDNINGER TIL STOMIINDRETNINGER OMFATTENDE ET KLÆBENDE HUDBARRIEREELEMENT MED EN FLERBLADET YDRE OMKREDS**
- (56) Fremdragne publikationer:
EP-A2- 0 882 437
WO-A1-2015/180731
JP-A- H10 248 867
US-A1- 2002 032 418
US-A1- 2004 106 908
US-A1- 2011 218 507
US-A1- 2014 114 265
US-B2- 6 790 200
US-B2- 8 328 779

DESCRIPTION

FIELD OF THE INVENTION

[0001] The present invention relates generally to mounting assemblies for ostomy appliances, and more particularly to mounting assemblies for ostomy appliances as set out in claim 1.

BACKGROUND OF THE INVENTION

[0002] Ostomates are individuals that have undergone a surgery to create an opening in the body, termed an ostomy, that allows for discharge of body waste. The surgery includes preparation of a stoma, corresponding to the end of an organ such as the colon, small intestine, or ureter, that protrudes through the abdominal wall and through which the body waste is discharged. An ostomy appliance can be attached to a skin surface around the ostomy, termed a peristomal skin surface, for collection of the body waste.

[0003] Various types of ostomy appliances have been disclosed. For example, Fenton, U.S. Pat. No. 6,790,200, discloses an ostomy appliance and a mounting disc that include an ostomy pouch having a stoma receiving portal. The mounting disc is sealed about the portal and includes a flexible plastic disc having a convex central body portion and a surrounding annular rim. A first foam disc having an outer diameter corresponding to the outer diameter of the rim is adhesively adhered to the plastic disc. A second foam disc is adhered to an adhesive face of the first foam disc and has an outer diameter greater than the plastic disc. A hydrocolloid skin shield disc having an outer diameter corresponding to the outer diameter of the second foam disc is adhesively adhered to an adhesive face of the second disc.

[0004] Also for example, Fenton, U.S. Pat. No. 8,328,779, discloses a mounting assembly for an ostomy pouch. The assembly includes a body flange having an adhesive coating on one side adapted to be adhered to the peristomal skin surface of an ostomate. Diametrically opposed loops project from the edge of the flange and form pockets. An ostomy pouch having a stoma receiving opening surrounded by a stiffly flexible ring having diametrically opposed loops that cooperate with the pockets on the flange loops is also disclosed. An adhesive coating is provided on the flexible ring and flange. When the loops on the flexible ring are aligned with the pockets on the flange, the flange and ring may be adhesively interlocked to attach the pouch to the body flange.

[0005] Prior art document US2014/114265 discloses an ostomy appliance for attachment to a stoma, the ostomy appliance comprising: an adhesive wafer defining a passage for receiving a stoma of a user, the adhesive wafer comprising a backing layer and a skin facing adhesive layer; and a collecting bag which in use is secured to the adhesive wafer; wherein the adhesive wafer in a first adhesive zone has a first set of properties and in a second adhesive zone has a

second set of properties, the first zone defining three or more radially extending zones, wherein the second zone defines one or more interconnecting parts, each of which interconnects at least two of the radially extending zones.

[0006] Prior art document WO2015180731 discloses an ostomy wafer comprising a central peristomal area surrounding a stoma receiving hole, from which a plurality of petals are extending radially, the petals being interconnected via bridges with a apex pointing away from the central area. The wafer is suitable for application to especially demanding skin surface conditions, such as in ostomists suffering from hernia.

[0007] Prior art document EP0882437 discloses an ostomy appliance having concave contour portions between tongues, includes a collection bag securable to faceplate, and an adhesive wafer having radially extending tongues and concave contour portions between the tongues.

[0008] Prior art document GB2311467 discloses an ostomy appliance comprises a pouch and an adhesive flange that is coupled to the pouch for securing the appliance with respect to the skin of the wearer.

[0009] The flange has an aperture that acts in communication with an interior of the pouch and has a number of fingers that extend away from the aperture. The fingers extend in directions that are substantially uniform and angularly around the periphery of the aperture. Each of the fingers is partly defined by a pair of side edges that diverge away from the aperture so that the distance between the edges increases with the distance from the aperture.

[0010] Prior art document JPH10248867 discloses a stoma bag and ring for a stoma bag comprising an adhesive flange which surrounds the opening part and can be bent has an approximately ring inside an area of the diameter (d) approximately 85mm and the outside area and has radial projections or flaps arranged at the same intervals in the circumferential direction. The projections are set to partial circles or crescent shapes having projecting and curved circumferential parts. The rear face of the flange, namely, the face to a patient is protected by an abrasive sheet.

[0011] Much effort has been invested in improving ostomy appliances, and in developing accessories, to make use of ostomy appliances as comfortable as possible. Yet ostomates still may have difficulty initially identifying an ostomy appliance that provides a suitable fit and still may be reluctant to try different ostomy appliances based on concern that a different fit will not be suitable.

[0012] Accordingly, a need exists for ostomy appliances that can provide improved fit and increased comfort for ostomates generally.

BRIEF SUMMARY OF THE INVENTION

[0013] A mounting assembly for an ostomy appliance as set out in claim 1 is disclosed.

[0014] In accordance with some examples, the flexible plastic member further comprises a central dome.

[0015] Also in accordance with some examples, the body flange further comprises (a) a first double-sided adhesive substrate member adhered to the flexible plastic member opposite the flange ring, and having a size smaller than the multi-petaled outer perimeter of the adhesive skin barrier member, and (b) a second double-sided adhesive substrate member adhered to the first double-sided adhesive substrate member and the adhesive skin barrier member and having a multi-petaled outer perimeter that substantially corresponds in size and shape to the multi-petaled outer perimeter of the adhesive skin barrier member.

[0016] Also in accordance with some examples, the adhesive skin barrier member has a maximum radius, and at least 50% of the multi-petaled outer perimeter of the adhesive skin barrier member extends to the maximum radius of the adhesive skin barrier member.

[0017] Also in accordance with some examples, the shape of the multi-petaled outer perimeter of the adhesive skin barrier member corresponds to 3 to 6 petals.

[0018] Also in accordance with some examples, the rim of the flexible plastic member is substantially annular.

[0019] Also in accordance with some examples, the first and second loops are diametrically opposed, and the third and fourth loops are diametrically opposed.

[0020] Also in accordance with some examples, the adhesive skin barrier member comprises an elastomer hydrocolloid mixture.

[0021] Also in accordance with some examples, the mounting assembly further comprises a first removable protective film covering the adhesive skin barrier member, and a second removable protective film covering the adhesive coating on the pouch ring.

[0022] Also in accordance with some examples, the flexible plastic member and the adhesive skin barrier member each have a stoma inlet portal, centrally positioned and extending therethrough.

[0023] An ostomy appliance also is disclosed. The ostomy appliance comprises a mounting assembly as set out in claim 1.

[0024] The body flange and the ostomy pouch are in assembled engagement based on the third and fourth loops engaging within the pocket of the first and second loops, respectively, the pouch ring fitting around the flange ring, and the rim of the flexible plastic member contacting the adhesive coating on the pouch ring.

[0025] Also disclosed as background of the invention is a method of adhering an ostomy appliance to an ostomate at a peristomal skin surface of the ostomate. In accordance with the method, the ostomy appliance comprises a mounting assembly.

[0026] The mounting assembly comprises a body flange. The body flange comprises a flexible plastic member located on a first side of the body flange. The flexible plastic member comprises a flange ring projecting axially from the body flange. The flexible plastic member also comprises a rim surrounding the flange ring. The flexible plastic member also comprises first and second loops extending radially from the rim. Each of the first and second loops comprises a raised fence around an opening that forms a pocket. The body flange also comprises an adhesive skin barrier member located on an opposite second side of the body flange. The mounting assembly also comprises an ostomy pouch. The ostomy pouch comprises a proximal sheet having an aperture. The ostomy pouch also comprises a distal sheet sealed to the proximal sheet at their respective peripheries to form the ostomy pouch. The ostomy pouch also comprises a pouch ring attached to the proximal sheet, surrounding the aperture of the proximal sheet. The pouch ring comprises an adhesive coating on the pouch ring. The pouch ring also comprises third and fourth loops extending radially from the pouch ring. The body flange and ostomy pouch are configured for the third and fourth loops to engage within the pocket of the first and second loops, respectively, the pouch ring to fit around the flange ring, and the rim of the flexible plastic member to contact the adhesive coating on the pouch ring, for assembly of the ostomy appliance. The adhesive skin barrier member has a multi-petaled outer perimeter that has a shape corresponding to 2 to 8 petals extending radially from the adhesive skin barrier member, distributed uniformly around the adhesive skin barrier member, and separated by notches that expand radially from the adhesive skin barrier member.

[0027] The flexible plastic member and the adhesive skin barrier member each have a stoma inlet portal, centrally positioned and extending therethrough.

[0028] The method comprises a step of (1) placing the adhesive skin barrier member at the peristomal region of the ostomate, such that the stoma inlet portals of the flexible plastic member and the adhesive skin barrier member are aligned with a stoma of the ostomate. The method also comprises a step of (2) engaging the third loop with the pocket of the first loop. The method also comprises a step of (3) fitting the pouch ring around the flange ring. The method also comprises a step of (4) engaging the fourth loop with the pocket of the second loop. The method also comprises a step of (5) contacting the rim of the flexible plastic member to the adhesive coating on the pouch ring. In accordance with the method, the ostomy appliance is thereby adhered to the ostomate at the peristomal skin surface of the ostomate.

[0029] In accordance with some examples, the mounting assembly further comprises a first removable protective film covering the adhesive skin barrier member, and a second removable protective film covering the adhesive coating on the pouch ring. In accordance with these examples, the method further comprises a step of removing the first removable protective film

from the adhesive skin barrier member prior to step (1), and a step of removing the second removable protective film from the adhesive coating on the pouch ring prior to steps (2) to (5).

[0030] Also in accordance with some examples, the ostomy appliance adheres to the ostomate at the peristomal skin surface of the ostomate with a smooth fit.

[0031] Also in accordance with some examples, the ostomy appliance adheres to the ostomate at the peristomal skin surface of the ostomate without application of adhesive tape to the ostomy appliance or to the ostomate.

[0032] Also disclosed as background of the invention is another method of adhering an ostomy appliance to an ostomate at a peristomal skin surface of the ostomate. In accordance with the method, the ostomy appliance comprises a mounting assembly.

[0033] The mounting assembly comprises a body flange. The body flange comprises a flexible plastic member located on a first side of the body flange. The flexible plastic member comprises a flange ring projecting axially from the body flange. The flexible plastic member also comprises a rim surrounding the flange ring. The flexible plastic member also comprises first and second loops extending radially from the rim. Each of the first and second loops comprises a raised fence around an opening that forms a pocket. The body flange also comprises an adhesive skin barrier member located on an opposite second side of the body flange. The mounting assembly also comprises an ostomy pouch. The ostomy pouch comprises a proximal sheet having an aperture. The ostomy pouch also comprises a distal sheet sealed to the proximal sheet at their respective peripheries to form the ostomy pouch. The ostomy pouch also comprises a pouch ring attached to the proximal sheet, surrounding the aperture of the proximal sheet. The pouch ring comprises an adhesive coating on the pouch ring. The pouch ring also comprises third and fourth loops extending radially from the pouch ring. The body flange and ostomy pouch are configured for the third and fourth loops to engage within the pocket of the first and second loops, respectively, the pouch ring to fit around the flange ring, and the rim of the flexible plastic member to contact the adhesive coating on the pouch ring, for assembly of the ostomy appliance. The adhesive skin barrier member has a multi-petaled outer perimeter that has a shape corresponding to 2 to 8 petals extending radially from the adhesive skin barrier member, distributed uniformly around the adhesive skin barrier member, and separated by notches that expand radially from the adhesive skin barrier member.

[0034] The method comprises a step of (0) cutting a stoma inlet portal through at least the adhesive skin barrier member, such that the flexible plastic member and the adhesive skin barrier member each have a stoma inlet portal, centrally positioned and extending therethrough. The method also comprises a step of (1) placing the adhesive skin barrier member at the peristomal region of the ostomate, such that the stoma inlet portals of the flexible plastic member and the adhesive skin barrier member are aligned with a stoma of the ostomate. The method also comprises a step of (2) engaging the third loop with the pocket of the first loop. The method also comprises a step of (3) fitting the pouch ring around the flange

ring. The method also comprises a step of (4) engaging the fourth loop with the pocket of the second loop. The method also comprises a step of (5) contacting the rim of the flexible plastic member to the adhesive coating on the pouch ring. In accordance with the method, the ostomy appliance is thereby adhered to the ostomate at the peristomal skin surface of the ostomate.

[0035] In accordance with some examples, the mounting assembly further comprises a first removable protective film covering the adhesive skin barrier member, and a second removable protective film covering the adhesive coating on the pouch ring. In accordance with these examples, the method further comprises a step of removing the first removable protective film from the adhesive skin barrier member prior to steps (0) and (1), and a step of removing the second removable protective film from the adhesive coating on the pouch ring prior to steps (2) to (5).

[0036] Also in accordance with some examples, the ostomy appliance adheres to the ostomate at the peristomal skin surface of the ostomate with a smooth fit.

[0037] Also in accordance with some examples, the ostomy appliance adheres to the ostomate at the peristomal skin surface of the ostomate without application of adhesive tape to the ostomy appliance or to the ostomate.

BRIEF DESCRIPTION OF THE DRAWINGS

[0038] These and other features, aspects, and advantages of the claimed mounting assemblies, ostomy appliances, and methods are better understood when the following detailed description is read with reference to the accompanying drawings, in which:

FIG. 1 is a top plan view of a body flange of a mounting assembly for an ostomy appliance as disclosed;

FIG. 2 is an inverted sectional view, the plane of the section being indicated by the line 2-2 in FIG. 1;

FIG. 3 is a bottom plan view of a body flange of a mounting assembly for an ostomy appliance as disclosed;

FIG. 4 is a front elevational view of an ostomy pouch of a mounting assembly for an ostomy appliance as disclosed;

FIG. 5 is a sectional view, the plane of the section being indicated by the line 5-5 in FIG. 4;

FIG. 6 is a top plan view of an adhesive skin barrier member of a body flange of a mounting assembly for an ostomy appliance as disclosed; and

FIG. 7 is a front elevational view of an ostomy appliance assembled as disclosed.

FIG. 8 shows photographs of a multi-petaled body flange of a mounting assembly for an ostomy appliance and a circular (non-multi-petaled) body flange of a mounting assembly for an ostomy appliance applied to a curved surface of a ball (A) immediately after application and (B) approximately 24 hours after application.

FIG. 9 shows photographs of a multi-petaled body flange of a mounting assembly for an ostomy appliance and a circular (non-multi-petaled) body flange of a mounting assembly for an ostomy appliance applied to a curved surface of a vase (A) immediately after application and (B) approximately 24 hours after application.

FIG. 10 shows photographs of a multi-petaled body flange of a mounting assembly for an ostomy appliance and a circular (non-multi-petaled) body flange of a mounting assembly for an ostomy appliance applied to a curved surface of a ball (A) immediately after application and (B) approximately 24 hours after application.

FIG. 11 shows photographs of a multi-petaled body flange of a mounting assembly for an ostomy appliance and a circular (non-multi-petaled) body flange of a mounting assembly for an ostomy appliance applied to a curved surface of a vase (A) immediately after application and (B) approximately 24 hours after application.

DETAILED DESCRIPTION OF THE INVENTION

[0039] A mounting assembly for an ostomy appliance **12** is disclosed (FIG. 1 to FIG. 7). The mounting assembly comprises a body flange **14** (FIG. 1, FIG. 2, and FIG. 3). The body flange **14** comprises a flexible plastic member **16** located on a first side of the body flange **14**. The flexible plastic member **16** comprises a flange ring **18** projecting axially from the body flange **14**. The flexible plastic member **16** also comprises a rim **20** surrounding the flange ring **18**. The flexible plastic member **16** also comprises first and second loops **22, 24** extending radially from the rim **20**. Each of the first and second loops **22, 24** comprises a raised fence **26** around an opening that forms a pocket **28**. The body flange **14** also comprises an adhesive skin barrier member **30** located on an opposite second side of the body flange **14**.

[0040] The mounting assembly also comprises an ostomy pouch **32** (FIG. 4 and FIG. 5). The ostomy pouch **32** comprises a proximal sheet **34** having an aperture **36**. The ostomy pouch **32** also comprises a distal sheet **38** sealed to the proximal sheet **34** at their respective peripheries to form the ostomy pouch **32**. The ostomy pouch **32** also comprises a pouch ring **40** attached to the proximal sheet **34**, surrounding the aperture **36** of the proximal sheet **34**. The pouch ring **40** comprises an adhesive coating **42** on the pouch ring **40**. The pouch ring **40** also comprises third and fourth loops **44, 46** extending radially from the pouch ring **40**.

[0041] The body flange **14** and ostomy pouch **32** are configured for the third and fourth loops **44, 46** to engage within the pocket **28** of the first and second loops **22, 24**, respectively, the

pouch ring **40** to fit around the flange ring **18**, and the rim **20** of the flexible plastic member **16** to contact the adhesive coating **42** on the pouch ring **40**, for assembly of the ostomy appliance **12** (FIG. 1, FIG. 4, and FIG. 7).

[0042] The adhesive skin barrier member **30** has a multi-petaled outer perimeter **48** that has a shape corresponding to 2 to 8 petals **50** extending radially from the adhesive skin barrier member **30**, distributed uniformly around the adhesive skin barrier member **30**, and separated by notches **52** that expand radially from the adhesive skin barrier member **30** (FIG. 6).

[0043] The mounting assembly provides improved fit of the adhesive skin barrier member **30** at a peristomal region of an ostomate, e.g. such that a corresponding ostomy appliance **12** adheres to the ostomate at the peristomal skin surface of the ostomate with a smooth fit and/or that the ostomy appliance **12** adheres to the ostomate at the peristomal skin surface of the ostomate without need for application of adhesive tape to the ostomy appliance **12** or to the ostomate. The size and shape of the multi-petaled outer perimeter **48** of the adhesive skin barrier member **30** of the body flange **14** allows the adhesive skin barrier member **30** to be adapted to a peristomal skin surface of an ostomate, without undesirable bunching upon application, and this applies across a range of peristomal skin surface contours of ostomates, e.g. for ostomates with peristomal skin surfaces that are flat, curved, bulging, and/or irregular. Thus, this configuration provides improved fit and increased comfort for ostomates generally. As the pouch fills with body waste, the adhesive skin barrier member **30** will remain secure and stay attached at the peristomal skin surface of the ostomate, and not peel away. Moreover, the mounting assembly allows an ostomate to change ostomy pouches **32** multiple times without having to remove the body flange **14** from the peristomal skin surface of the ostomate.

[0044] As noted, the mounting assembly comprises a body flange **14** (FIG. 1, FIG. 2, and FIG. 3). The body flange **14** comprises a flexible plastic member **16**. The flexible plastic member **16** can be made from, for example, a copolymer of ethylene and vinyl acetate, e.g. the ELVAX(R) 450 product of DuPont. The flexible plastic member **16** is located on a first side of the body flange **14**.

[0045] The flexible plastic member **16** comprises a flange ring **18** projecting axially, e.g. along a major axis, from the body flange **14**. The flange ring **18** can have an inner diameter of, for example, 50 to 75 mm, 55 to 70 mm, 58 to 65 mm, or about 61 mm. The flange ring **18** can have an outer diameter of, for example, 55 to 85 mm, 60 to 80 mm, 63 to 75 mm, or about 68 mm. The flange ring **18** can have a radial width of, for example, 1 to 10 mm, 2 to 5 mm, or about 3 mm. The flange ring **18** can project axially, for example, 0.5 to 10 mm, 1 to 5 mm, or about 2 mm.

[0046] The flexible plastic member **16** also comprises a rim **20** surrounding the flange ring **18**. The rim **20** of the flexible plastic member **16** can have an outer diameter of, for example, 70 to 130 mm, 85 to 115 mm, 95 to 105 mm, or about 100 mm.

[0047] The flexible plastic member **16** also comprises first and second loops **22**, **24** extending

radially from the rim 20. Each of the first and second loops 22, 24 comprises a raised fence 26 around an opening that forms a pocket 28.

[0048] The body flange 14 also comprises an adhesive skin barrier member 30 located on an opposite second side of the body flange 14. The adhesive skin barrier member 30 can be made from a suitable material for providing a skin barrier, can be pliable, and can have both dry tack and wet tack.

[0049] The mounting assembly also comprises an ostomy pouch 32 (FIG. 4 and FIG. 5). The ostomy pouch 32 can be designed for single use, e.g. by not having an opening for draining contents of the ostomy pouch 32, or for multiple use, e.g. by having an opening for draining contents of the ostomy pouch 32.

[0050] The ostomy pouch 32 comprises a proximal sheet 34 having an aperture 36. The aperture 36 can have a diameter of, for example, 55 to 85 mm, 60 to 80 mm, 63 to 75 mm, or about 68 mm.

[0051] The ostomy pouch 32 also comprises a distal sheet 38 sealed to the proximal sheet 34 at their respective peripheries to form the ostomy pouch 32.

[0052] The ostomy pouch 32 also comprises a pouch ring 40 attached to the proximal sheet 34, surrounding the aperture 36 of the proximal sheet 34. The pouch ring 40 can be made from a plastic and can be flexible. The pouch ring 40 can be attached to the proximal sheet 34, for example based on an adhesive. The pouch ring 40 can surround the aperture 36 of the proximal sheet 34, for example based on the pouch ring 40 having an inner diameter and the aperture 36 of the proximal sheet 34 having a diameter, the inner diameter of the pouch ring 40 being greater than or equal to the diameter of the aperture 36 of the proximal sheet 34. The pouch ring 40 also can surround the aperture 36 of the proximal sheet 34, for example based on the pouch ring 40 being attached to the proximal sheet 34 at a portion of the proximal sheet 34 surrounding the aperture 36.

[0053] The pouch ring 40 comprises an adhesive coating 42 on the pouch ring 40.

[0054] The pouch ring 40 also comprises third and fourth loops 44, 46 extending radially from the pouch ring 40.

[0055] The body flange 14 and ostomy pouch 32 are configured for the third and fourth loops 44, 46 to engage within the pocket 28 of the first and second loops 22, 24, respectively, the pouch ring 40 to fit around the flange ring 18, and the rim 20 of the flexible plastic member 16 to contact the adhesive coating 42 on the pouch ring 40, for assembly of the ostomy appliance 12. Engagement of the third and fourth loops 44, 46 within the pocket 28 of the first and second loops 22, 24, respectively, and fitting of the pouch ring 40 around the flange ring 18, serve to locate the ostomy pouch 32 onto the body flange 14. Contacting the rim 20 of the flexible plastic member 16 to the adhesive coating 42 on the pouch ring 40 completes an

adhesive bond between the ostomy pouch **32** and the body flange **14**.

[0056] The adhesive skin barrier member **30** has a multi-petaled outer perimeter **48** that has a shape corresponding to 2 to 8 petals **50** extending radially from the adhesive skin barrier member **30**, distributed uniformly around the adhesive skin barrier member **30**, and separated by notches **52** that expand radially from the adhesive skin barrier member **30** (FIG. 6). For example, the multi-petaled outer perimeter **48** of the adhesive skin barrier member **30** can have a shape corresponding to 2 to 8 petals **50** extending radially from the adhesive skin barrier member **30**, distributed uniformly around the adhesive skin barrier member **30**, and separated by notches **52** that expand radially from the adhesive skin barrier member **30**, such that the adhesive skin barrier member **30** has a center, and each of the 2 to 8 petals **50** extend radially with respect to the center of the adhesive skin barrier member **30**. Also for example, the multi-petaled outer perimeter **48** of the adhesive skin barrier member **30** can have a shape corresponding to 2 to 8 petals **50** extending radially from the adhesive skin barrier member **30**, distributed uniformly around the adhesive skin barrier member **30**, and separated by notches **52** that expand radially from the adhesive skin barrier member **30**, such that each of the 2 to 8 petals **50** is substantially identical in size and that each of the 2 to 8 petals **50** is positioned equidistant from the petals **50** adjacent thereto. Also for example, the multi-petaled outer perimeter **48** of the adhesive skin barrier member **30** can have a shape corresponding to 2 to 8 petals **50** extending radially from the adhesive skin barrier member **30**, distributed uniformly around the adhesive skin barrier member **30**, and separated by notches **52** that expand radially from the adhesive skin barrier member **30**, such that each of the 2 to 8 petals **50** is separated from the petals **50** adjacent thereto by a notch **52** on either side thereof, each notch **52** having a notch width **54**, measured as an arcuate length with respect to the center of the adhesive skin barrier member **30**, that increases with increasing distance from the center of the adhesive skin barrier member **30**.

[0057] In accordance with some examples, the flexible plastic member **16** further comprises a central dome **56** (FIG. 1, FIG. 2, and FIG. 3). The central dome **56** can be oriented axially inwardly with respect to the body flange **14**, such that the flexible plastic member **16** is convex on a side of the flexible plastic member **16** opposite the side from which the flange ring **18** projects. For example, the central dome **56** can have a convexity of, for example, 2 to 15 mm, 4 to 12 mm, 5 to 11 mm, or 6 to 10 mm. Also for example, the central dome **56** can have a convexity of, for example, 2 mm, 3 mm, 4 mm, 5 mm, 6 mm, 7 mm, 8 mm, 9 mm, 10 mm, 11 mm, 12 mm, 13 mm, 14 mm, or 15 mm. In accordance with these examples, the central dome **56** can have a shape of, for example, a spherical cap, e.g. a dome with a rounded top, or a spherical segment, e.g. a dome with a flat top, among other shapes. Also in accordance with these examples, to the extent that the central dome **56** is convex, then, following assembly of the body flange **14**, corresponding overlapping portions of the adhesive skin barrier member **30** are also convex, and thus then the body flange **14** is also convex in corresponding portions thereof.

[0058] Also in accordance with some examples, the body flange **14** further comprises (a) a first double-sided adhesive substrate member **58** adhered to the flexible plastic member **16**

opposite the flange ring **18**, and having a size smaller than the multi-petaled outer perimeter **48** of the adhesive skin barrier member **30**, and (b) a second double-sided adhesive substrate member **60** adhered to the first double-sided adhesive substrate member **58** and the adhesive skin barrier member **30** and having a multi-petaled outer perimeter **49** that substantially corresponds in size and shape to the multi-petaled outer perimeter **48** of the adhesive skin barrier member **30**.

[0059] In accordance with these examples, the first double-sided adhesive substrate member **58** can be made from, for example, a foam layer, a thermoplastic layer, a polypropylene layer, a polyethylene layer, a nonwoven layer, and/or a film layer. Also, the first double-sided adhesive substrate member **58** can be a soft, resilient double-sided adhesive substrate member. Thus, in some examples the first double-sided adhesive substrate member **58** can comprise a foam layer, e.g. a soft, resilient foam layer.

[0060] Also in accordance with these examples, the second double-sided adhesive substrate member **60** also can be made from, for example, a foam layer, a thermoplastic layer, a polypropylene layer, a polyethylene layer, a nonwoven layer, and/or a film layer. Also, the second double-sided adhesive substrate member **60** can be a soft, resilient double-sided adhesive substrate member. Thus, in some examples the second double-sided adhesive substrate member **60** can comprise a foam layer, e.g. a soft, resilient foam layer.

[0061] Also in accordance with these examples, the first double-sided adhesive substrate member **58** can be adhered to the flexible plastic member **16** opposite the flange ring **18**, e.g. based on use of a pressure-sensitive adhesive layer, such that the first double-sided adhesive substrate member **58** is adhered to the flexible plastic member **16** on a side of the flexible plastic member **16** opposite the side from which the flange ring **18** projects.

[0062] Also in accordance with these examples, the second double-sided adhesive substrate member **60** can be adhered to the first double-sided adhesive substrate member **58** and the adhesive skin barrier member **30**, e.g. also based on use of a pressure-sensitive adhesive layer, such that the second double-sided adhesive substrate member **60** is adhered to the first double-sided adhesive substrate member **58** on a side of the first double-sided adhesive substrate member **58** opposite the side adhered to the flexible plastic member **16**, and to the adhesive skin barrier member **30** on a side of the adhesive skin barrier member **30** oriented toward the flexible plastic member **16**.

[0063] Also in accordance with these examples, with respect to size, for example the first double-sided adhesive substrate member **58** can have a size smaller than the multi-petaled outer perimeter **48** of the adhesive skin barrier member **30** such that when the adhesive skin barrier member **30** is positioned on the first double-sided adhesive substrate member **58** and is centered with respect thereto, the multi-petaled outer perimeter **48** of the adhesive skin barrier member **30** extends at least, for example, 5 to 25 mm, 8 to 20 mm, or 10 to 15 mm, beyond an outer perimeter **62** of the first double-sided adhesive substrate member **58** along at least 50% of the multi-petaled outer perimeter **48** of the adhesive skin barrier member **30**. Also

for example, the first double-sided adhesive substrate member **58** can have a size smaller than the multi-petaled outer perimeter **48** of the adhesive skin barrier member **30** such that when the adhesive skin barrier member **30** is positioned on the first double-sided adhesive substrate member **58** and is centered with respect thereto, the multi-petaled outer perimeter **48** of the adhesive skin barrier member **30** extends at least, for example, 0.2 to 25 mm, 0.5 to 20 mm, or 1 to 15 mm, beyond an outer perimeter **62** of the first double-sided adhesive substrate member **58** along at least 95%, at least 98%, or 100% of the multi-petaled outer perimeter **48** of the adhesive skin barrier member **30**.

[0064] Also in accordance with these examples, the notches **52** can expand radially from the adhesive skin barrier member **30**, starting from a distance radially beyond an outer perimeter **62** of the first double-sided adhesive substrate member **58**, e.g. a distance of 0.5 to 5 mm, 0.8 to 3 mm, or 1 to 2 mm, radially beyond an outer perimeter **62** of the first double-sided adhesive substrate member **58**. In accordance with these examples, during use of the ostomy appliance **12** as adhered to an ostomate, this configuration may provide additional improved fit based on formation of small tears in the adhesive skin barrier member **30** and the second double-sided adhesive substrate member **60**, extending from the notches **52** radially inwardly toward the outer perimeter **62** of first double-sided adhesive substrate member **58**.

[0065] Also in accordance with these examples, the second double-sided adhesive substrate member **60** can have a multi-petaled outer perimeter **49** that substantially corresponds in size and shape to the multi-petaled outer perimeter **48** of the adhesive skin barrier member **30** such that when the adhesive skin barrier member **30** is positioned on the second double-sided adhesive substrate member **60** in an orientation maximizing alignment thereof, the multi-petaled outer perimeter **48** of the adhesive skin barrier member **30** extends not more than, for example, 10 mm, 3 mm, or 1 mm beyond the multi-petaled outer perimeter **49** of the second double-sided adhesive substrate member **60** at any point along the multi-petaled outer perimeter **48** of the adhesive skin barrier member **30**. Also for example, the multi-petaled outer perimeter **48** of the adhesive skin barrier member **30** can correspond in size and shape to the multi-petaled outer perimeter **49** of the second double-sided adhesive substrate member **60** such that when the adhesive skin barrier member **30** is positioned on the second double-sided adhesive substrate member **60** in an orientation maximizing alignment thereof, the multi-petaled outer perimeter **49** of the second double-sided adhesive substrate member **60** extends not more than, for example, 10 mm, 3 mm, or 1 mm beyond the multi-petaled outer perimeter **48** of the adhesive skin barrier member **30** at any point along the multi-petaled outer perimeter **49** of the second double-sided adhesive substrate member **60**. Also for example, the multi-petaled outer perimeter **48** of the adhesive skin barrier member **30** can correspond in size and shape to the multi-petaled outer perimeter **49** of the second double-sided adhesive substrate member **60** such that the multi-petaled outer perimeter **48** of the adhesive skin barrier member **30** is identical in size and shape to the multi-petaled outer perimeter **49** of the second double-sided adhesive substrate member **60**. The multi-petaled outer perimeter **49** of the second double-sided adhesive substrate member **60** also has a shape corresponding to 2 to 8 petals extending radially from the second double-sided adhesive substrate member **60**, distributed uniformly around the second double-sided adhesive substrate member **60**, and separated by

notches that expand radially from the second double-sided adhesive substrate member 60.

[0066] In accordance with the invention, the 2 to 8 petals 50 each have a petal width 64 that first increases, then decreases, radially outwardly from the adhesive skin barrier member 30 (FIG. 6). For example, the 2 to 8 petals 50 each can have a petal width 64 that first increases, then decreases, radially outwardly from the adhesive skin barrier member 30, such that the adhesive skin barrier member 30 has a center, and the 2 to 8 petals 50 each have a petal width 64, measured as an arcuate length with respect to the center of the adhesive skin barrier member 30, that first increases, then decreases, with increasing distance from the center of the adhesive skin barrier member 30.

[0067] Also in accordance with some examples, the adhesive skin barrier member 30 has a maximum radius 66, and at least 50% of the multi-petaled outer perimeter 48 of the adhesive skin barrier member 30 extends to the maximum radius 66 of the adhesive skin barrier member 30. For example, the adhesive skin barrier member 30 can have a maximum radius 66, and at least 50% of the multi-petaled outer perimeter 48 of the adhesive skin barrier member 30 can extend to the maximum radius 66 of the adhesive skin barrier member 30, such that, for example, at least 50%, 60%, 70% or 80% of the multi-petaled outer perimeter 48 of the adhesive skin barrier member 30 extends to the same distance from the center of the adhesive skin barrier member 30 and no point on the multi-petaled outer perimeter 48 of the adhesive skin barrier member 30 extends further than this. In accordance with these examples, the second double-sided adhesive substrate member 60, if present, can also be dimensioned this way.

[0068] Also in accordance with some examples, the shape of the multi-petaled outer perimeter 48 of the adhesive skin barrier member 30 corresponds to 3 to 6 petals 50. For example, the shape of the multi-petaled outer perimeter 48 of the adhesive skin barrier member 30 can correspond, for example, to 3 petals 50, 4 petals 50, 5 petals 50, or 6 petals 50. In accordance with these examples, the second double-sided adhesive substrate member 60, if present, can also be dimensioned this way.

[0069] Also in accordance with some examples, the rim 20 of the flexible plastic member 16 is substantially annular (FIG. 3). For example, the rim 20 of the flexible plastic member 16 can be circular. In other examples, the rim 20 of the flexible plastic member 16 can have other shapes, e.g. oval, polygonal, etc.

[0070] Also in accordance with some examples, the first and second loops 22, 24 are diametrically opposed, and the third and fourth loops 44, 46 are diametrically opposed (FIG. 1, FIG. 4, and FIG. 7). The first and second loops 22, 24 and the third and fourth loops 44, 46 can be used to align the body flange 14 and the ostomy pouch 32 during assembly of the ostomy appliance 12.

[0071] Also in accordance with some examples, the adhesive skin barrier member 30 comprises an elastomer hydrocolloid mixture. The elastomer hydrocolloid mixture can include,

for example, a Karaya-glycerine formulation, mixtures of polyacrylamide resins, and/or other polyols.

[0072] Also in accordance with some examples, the mounting assembly further comprises a first removable protective film **68** covering the adhesive skin barrier member **30**, and a second removable protective film **70** covering the adhesive coating **42** on the pouch ring **40** (FIG. 1, FIG. 2, FIG. 4, and FIG. 5). In some examples, the first removable protective film **68** can include a part, such as a tab **72**, that extends continuously beyond the multi-petaled outer perimeter **48** of the adhesive skin barrier member **30**, and that can be used to remove the first removable protective film **68** from the adhesive skin barrier member **30**.

[0073] Also in accordance with some examples, the flexible plastic member **16** and the adhesive skin barrier member **30** each have a stoma inlet portal **74**, **76** respectively, centrally positioned and extending therethrough, which together form a stoma inlet portal **78** of the body flange **14** (FIG. 3). The stoma inlet portals **74**, **76** of the flexible plastic member **16** and the adhesive skin barrier member **30**, respectively, can have a size and shape suitable for a stoma (designated **S** in FIG. 2) of an ostomate. For example, the stoma inlet portals **74**, **76** of the flexible plastic member **16** and the adhesive skin barrier member **30** can have a size corresponding to a diameter of, for example, 10 mm to 50 mm, e.g. about 12 to 13 mm, about 15 to 16 mm, about 22 to 23 mm, about 25 to 26 mm, about 28 to 29 mm, about 31 to 32 mm, about 34 to 35 mm, about 38 to 39 mm, about 41 to 42 mm, or about 44 to 45 mm. Also for example, the stoma inlet portals **74**, **76** of the flexible plastic member **16** and the adhesive skin barrier member **30** can have a size corresponding to a diameter of, for example, 12.7 mm, 15.9 mm, 22.2 mm, 25.4 mm, 28.6 mm, 31.8 mm, 34.9 mm, 41.3 mm, or 44.5 mm. Also for example, the stoma inlet portals **74**, **76** of the flexible plastic member **16** and the adhesive skin barrier member **30** can have a shape corresponding to a circle. Also for example, the stoma inlet portals **74**, **76** of the flexible plastic member **16** and the adhesive skin barrier member **30** can have a shape that is cut to fit a stoma of an ostomate. Also for example, the first double-sided adhesive substrate member **58**, if present, and the second double-sided adhesive substrate member **60**, if present, also can each have a stoma inlet portal, respectively, centrally positioned and extending therethrough, which together also form the stoma inlet portal **78** of the body flange **14**.

[0074] The body flange **14** and the ostomy pouch **32** of the mounting assembly can be assembled, to form the ostomy appliance **12**, as follows (FIG. 7). The third and fourth loops **44**, **46** can be engaged within the pocket **28** of the first and second loops **22**, **24**, respectively (FIG. 1 and FIG. 4). This can be done, for example, sequentially, e.g. based on engaging the third loop **44** within the pocket **28** of the first loop **22**, then later engaging the fourth loop **46** within the pocket **28** of the second loop **24**. This also can be done, for example, simultaneously, e.g. based on engaging the third loop **44** within the pocket **28** of the first loop **22**, and simultaneously engaging the fourth loop **46** within the pocket **28** of the second loop **24**. The engagement can align pouch ring **40** around the flange ring **18** (FIG. 2 and FIG. 4). The pouch ring **40** can then be fit around the flange ring **18**, e.g. by snapping the pouch ring **40** in place around the flange ring **18**. This puts the rim **20** of the flexible plastic member **16** adjacent the

adhesive coating 42 on the pouch ring 40. The rim 20 of the flexible plastic member 16 can then be put in contact with the adhesive coating 42 on the pouch ring 40. This completes and adhesive bond between ostomy pouch 32 and the body flange 14. Other approaches for assembly of the body flange 14 and the ostomy pouch 32 to form the ostomy appliance 12 also can be used.

[0075] The ostomy appliance 12 also can be disassembled, to separate the ostomy pouch 32 from the body flange 14, e.g. to replace the ostomy pouch 32 as used with an ostomy pouch 32 that has not yet been used, as follows (FIG. 1, FIG. 4, and FIG. 7). In some examples, the rim 20 of the flexible plastic member 16 further comprises a tab 80 extending axially therefrom, and the pouch ring 40 also further comprises a tab 82 extending axially therefrom. In accordance with these examples, the tab 80 of the flexible plastic member 16 and the tab 82 of the pouch ring 40 can each be grasped independently. Then the tab 82 of the pouch ring 40 can be pulled, releasing the rim 20 of the flexible plastic member 16 from contact with the adhesive coating 42 on the pouch ring 40, releasing the pouch ring 40 from around the flange ring 18, and releasing the third and fourth loops 44, 46 from the pocket 28 of each of the first and second loops 22, 24. Other approaches for disassembly of the ostomy appliance 12 also can be used.

[0076] An ostomy appliance 12 also is disclosed (FIG. 7). The ostomy appliance 12 comprises a mounting assembly.

[0077] The mounting assembly is as described above. Accordingly, the mounting assembly comprises a body flange 14. The body flange 14 comprises a flexible plastic member 16 located on a first side of the body flange 14. The flexible plastic member 16 comprises a flange ring 18 projecting axially from the body flange 14. The flexible plastic member 16 also comprises a rim 20 surrounding the flange ring 18. The flexible plastic member 16 also comprises first and second loops 22, 24 extending radially from the rim 20. Each of the first and second loops 22, 24 comprises a raised fence 26 around an opening that forms a pocket 28. The body flange 14 also comprises an adhesive skin barrier member 30 located on an opposite second side of the body flange 14. The mounting assembly also comprises an ostomy pouch 32. The ostomy pouch 32 comprises a proximal sheet 34 having an aperture 36. The ostomy pouch 32 also comprises a distal sheet 38 sealed to the proximal sheet 34 at their respective peripheries to form the ostomy pouch 32. The ostomy pouch 32 also comprises a pouch ring 40 attached to the proximal sheet 34, surrounding the aperture 36 of the proximal sheet 34. The pouch ring 40 comprises an adhesive coating 42 on the pouch ring 40. The pouch ring 40 also comprises third and fourth loops 44, 46 extending radially from the pouch ring 40. The body flange 14 and ostomy pouch 32 are configured for the third and fourth loops 44, 46 to engage within the pocket 28 of the first and second loops 22, 24, respectively, the pouch ring 40 to fit around the flange ring 18, and the rim 20 of the flexible plastic member 16 to contact the adhesive coating 42 on the pouch ring 40, for assembly of the ostomy appliance 12. The adhesive skin barrier member 30 has a multi-petaled outer perimeter 48 that has a shape corresponding to 2 to 8 petals 50 extending radially from the adhesive skin barrier member 30, distributed uniformly around the adhesive skin barrier member 30, and separated

by notches **52** that expand radially from the adhesive skin barrier member **30**.

[0078] The body flange **14** and the ostomy pouch **32** are in assembled engagement based on the third and fourth loops **44, 46** engaging within the pocket **28** of the first and second loops **22, 24**, respectively, the pouch ring **40** fitting around the flange ring **18**, and the rim **20** of the flexible plastic member **16** contacting the adhesive coating **42** on the pouch ring **40**.

[0079] In accordance with some examples, the flexible plastic member **16** further comprises a central dome **56**.

[0080] Also in accordance with some examples, the body flange **14** further comprises (a) a first double-sided adhesive substrate member **58** adhered to the flexible plastic member **16** opposite the flange ring **18**, and having a size smaller than the multi-petaled outer perimeter **48** of the adhesive skin barrier member **30**, and (b) a second double-sided adhesive substrate member **60** adhered to the first double-sided adhesive substrate member **58** and the adhesive skin barrier member **30** and having a multi-petaled outer perimeter **49** that substantially corresponds in size and shape to the multi-petaled outer perimeter **48** of the adhesive skin barrier member **30**.

[0081] In accordance with the invention, the 2 to 8 petals **50** each have a width that first increases, then decreases, radially outwardly from the adhesive skin barrier member **30**.

[0082] Also in accordance with some examples, the adhesive skin barrier member **30** has a maximum radius **66**, and at least 50% of the multi-petaled outer perimeter **48** of the adhesive skin barrier member **30** extends to the maximum radius **66** of the adhesive skin barrier member **30**.

[0083] Also in accordance with some examples, the shape of the multi-petaled outer perimeter **48** of the adhesive skin barrier member **30** corresponds to 3 to 6 petals **50**.

[0084] Also in accordance with some examples, the rim **20** of the flexible plastic member **16** is substantially annular.

[0085] Also in accordance with some examples, the first and second loops **22, 24** are diametrically opposed, and the third and fourth loops **44, 46** are diametrically opposed.

[0086] Also in accordance with some examples, the adhesive skin barrier member **30** comprises an elastomer hydrocolloid mixture.

[0087] Also in accordance with some examples, the mounting assembly further comprises a first removable protective film **68** covering the adhesive skin barrier member **30**, and a second removable protective film **70** covering the adhesive coating **42** on the pouch ring **40**.

[0088] The ostomy appliance **12** can be disassembled, to separate the ostomy pouch **32** from

the body flange **14**, e.g. to replace the ostomy pouch **32** as used with an ostomy pouch **32** that has not yet been used, as described above. Thus, in some examples, the rim **20** of the flexible plastic member **16** further comprises a tab **80** extending axially therefrom, and the pouch ring **40** also further comprises a tab **82** extending axially therefrom, and in accordance with these examples, the tab **80** of the flexible plastic member **16** and the tab **82** of the pouch ring **40** can be used for disassembly of the ostomy appliance **12** as described above.

[0089] Also disclosed is a method of adhering an ostomy appliance **12** to an ostomate at a peristomal skin surface of the ostomate. In accordance with the method, the ostomy appliance **12** comprises a mounting assembly.

[0090] The mounting assembly is as described above. Accordingly, the mounting assembly comprises a body flange **14**. The body flange **14** comprises a flexible plastic member **16** located on a first side of the body flange **14**. The flexible plastic member **16** comprises a flange ring **18** projecting axially from the body flange **14**. The flexible plastic member **16** also comprises a rim **20** surrounding the flange ring **18**. The flexible plastic member **16** also comprises first and second loops **22**, **24** extending radially from the rim **20**. Each of the first and second loops **22**, **24** comprises a raised fence **26** around an opening that forms a pocket **28**. The body flange **14** also comprises an adhesive skin barrier member **30** located on an opposite second side of the body flange **14**. The mounting assembly also comprises an ostomy pouch **32**. The ostomy pouch **32** comprises a proximal sheet **34** having an aperture **36**. The ostomy pouch **32** also comprises a distal sheet **38** sealed to the proximal sheet **34** at their respective peripheries to form the ostomy pouch **32**. The ostomy pouch **32** also comprises a pouch ring **40** attached to the proximal sheet **34**, surrounding the aperture **36** of the proximal sheet **34**. The pouch ring **40** comprises an adhesive coating **42** on the pouch ring **40**. The pouch ring **40** also comprises third and fourth loops **44**, **46** extending radially from the pouch ring **40**. The body flange **14** and ostomy pouch **32** are configured for the third and fourth loops **44**, **46** to engage within the pocket **28** of the first and second loops **22**, **24**, respectively, the pouch ring **40** to fit around the flange ring **18**, and the rim **20** of the flexible plastic member **16** to contact the adhesive coating **42** on the pouch ring **40**, for assembly of the ostomy appliance. The adhesive skin barrier member **30** has a multi-petaled outer perimeter **48** that has a shape corresponding to 2 to 8 petals **50** extending radially from the adhesive skin barrier member **30**, distributed uniformly around the adhesive skin barrier member **30**, and separated by notches **52** that expand radially from the adhesive skin barrier member **30**.

[0091] The flexible plastic member **16** and the adhesive skin barrier member **30** each have a stoma inlet portal **74**, **76**, respectively, centrally positioned and extending therethrough.

[0092] The method comprises a step of (1) placing the adhesive skin barrier member **30** at the peristomal region of the ostomate, such that the stoma inlet portals **74**, **76** of the flexible plastic member **16** and the adhesive skin barrier member **30** are aligned with a stoma of the ostomate. The method also comprises a step of (2) engaging the third loop **44** with the pocket **28** of the first loop **22**. The method also comprises a step of (3) fitting the pouch ring **40** around the flange ring **18**. The method also comprises a step of (4) engaging the fourth loop **46** with

the pocket **28** of the second loop **24**. The method also comprises a step of (5) contacting the rim **20** of the flexible plastic member **16** to the adhesive coating **42** on the pouch ring **40**. In accordance with the method, the ostomy appliance **12** is thereby adhered to the ostomate at the peristomal skin surface of the ostomate. Although the steps are presented in order of steps (1) to step (5), the steps may be carried out in other orders as appropriate, e.g. in an order of steps (1), (2), (4), (3), and (5), among others orders. Moreover, certain steps may be carried out simultaneously as appropriate, e.g. steps (2) and (4) may be carried out simultaneously.

[0093] In accordance with some examples, the mounting assembly further comprises a first removable protective film **68** covering the adhesive skin barrier member **30**, and a second removable protective film **70** covering the adhesive coating **42** on the pouch ring **40**. In accordance with these examples, the method further comprises a step of removing the first removable protective film **68** from the adhesive skin barrier member **30** prior to step (1), and a step of removing the second removable protective film **70** from the adhesive coating **42** on the pouch ring **40** prior to steps (2) to (5).

[0094] In accordance with some examples, the ostomy appliance **12** adheres to the ostomate at the peristomal skin surface of the ostomate with a smooth fit. For example, the ostomy appliance **12** can adhere to the ostomate at the peristomal skin surface of the ostomate with a smooth fit such that the multi-petaled body flange **14** is adapted to the peristomal skin surface of the ostomate, without undesirable bunching upon application. Also for example, the ostomy appliance **12** can adhere to the ostomate at the peristomal skin surface of the ostomate with a smooth fit across a range of peristomal skin surface contours of ostomates, e.g. for ostomates with peristomal skin surfaces that are flat, curved, bulging, and/or irregular. As the pouch fills with body waste, the adhesive skin barrier member **30** will remain secure and stay attached at the peristomal skin surface of the ostomate, and not peel away.

[0095] Also in accordance with some examples, the ostomy appliance **12** adheres to the ostomate at the peristomal skin surface of the ostomate without application of adhesive tape to the ostomy appliance **12** or to the ostomate. For example, the ostomy appliance **12** can adhere to the ostomate at the peristomal skin surface of the ostomate without application of adhesive tape to the ostomy appliance **12** or to the ostomate such that no adhesive tape needs to be applied to smooth, press, or adhere the body flange **14** to the skin at and adjacent the peristomal skin surface of the ostomate. Also for example, the ostomy appliance **12** can adhere to the ostomate at the peristomal skin surface of the ostomate without application of adhesive tape to the ostomy appliance **12** or to the ostomate across a range of peristomal skin surface contours of ostomates, e.g. for ostomates with peristomal skin surfaces that are flat, curved, bulging, and/or irregular. Again, as the pouch fills with body waste, the adhesive skin barrier member **30** will remain secure and stay attached at the peristomal skin surface of the ostomate, and not peel away.

[0096] In accordance with some examples, the flexible plastic member **16** further comprises a central dome **56**.

[0097] Also in accordance with some examples, the body flange **14** further comprises (a) a first double-sided adhesive substrate member **58** adhered to the flexible plastic member **16** opposite the flange ring **18**, and having a size smaller than the multi-petaled outer perimeter **48** of the adhesive skin barrier member **30**, and (b) a second double-sided adhesive substrate member **60** adhered to the first double-sided adhesive substrate member **58** and the adhesive skin barrier member **30** and having a multi-petaled outer perimeter **49** that substantially corresponds in size and shape to the multi-petaled outer perimeter **48** of the adhesive skin barrier member **30**.

[0098] Also in accordance with some examples, the 2 to 8 petals **50** each have a width that first increases, then decreases, radially outwardly from the adhesive skin barrier member **30**.

[0099] Also in accordance with some examples, the adhesive skin barrier member **30** has a maximum radius **66**, and at least 50% of the multi-petaled outer perimeter **48** of the adhesive skin barrier member **30** extends to the maximum radius **66** of the adhesive skin barrier member **30**.

[0100] Also in accordance with some examples, the shape of the multi-petaled outer perimeter **48** of the adhesive skin barrier member **30** corresponds to 3 to 6 petals **50**.

[0101] Also in accordance with some examples, the rim **20** of the flexible plastic member **16** is substantially annular.

[0102] Also in accordance with some examples, the first and second loops **22**, **24** are diametrically opposed, and the third and fourth loops **44**, **46** are diametrically opposed.

[0103] Also in accordance with some examples, the adhesive skin barrier member **30** comprises an elastomer hydrocolloid mixture.

[0104] Also in accordance with some examples, the mounting assembly further comprises a first removable protective film **68** covering the adhesive skin barrier member **30**, and a second removable protective film **70** covering the adhesive coating **42** on the pouch ring **40**.

[0105] Also in accordance with the method, the ostomy appliance **12** can be disassembled, to separate the ostomy pouch **32** from the body flange **14**, e.g. to replace the ostomy pouch **32** as used with an ostomy pouch **32** that has not yet been used, as described above. Thus, in some examples, the rim **20** of the flexible plastic member **16** further comprises a tab **80** extending axially therefrom, and the pouch ring **40** also further comprises a tab **82** extending axially therefrom, and in accordance with these examples, the tab **80** of the flexible plastic member **16** and the tab **82** of the pouch ring **40** can be used for disassembly of the ostomy appliance **12** as described above.

[0106] Also disclosed is another method of adhering an ostomy appliance **12** to an ostomate at a peristomal skin surface of the ostomate. In accordance with the method, the ostomy

appliance **12** comprises a mounting assembly.

[0107] The mounting assembly is as described above. Accordingly, the mounting assembly comprises a body flange **14**. The body flange **14** comprises a flexible plastic member **16** located on a first side of the body flange **14**. The flexible plastic member **16** comprises a flange ring **18** projecting axially from the body flange **14**. The flexible plastic member **16** also comprises a rim **20** surrounding the flange ring **18**. The flexible plastic member **16** also comprises first and second loops **22, 24** extending radially from the rim **20**. Each of the first and second loops **22, 24** comprises a raised fence **26** around an opening that forms a pocket **28**. The body flange **14** also comprises an adhesive skin barrier member **30** located on an opposite second side of the body flange **14**. The mounting assembly also comprises an ostomy pouch **32**. The ostomy pouch **32** comprises a proximal sheet **34** having an aperture **36**. The ostomy pouch **32** also comprises a distal sheet **38** sealed to the proximal sheet **34** at their respective peripheries to form the ostomy pouch **32**. The ostomy pouch **32** also comprises a pouch ring **40** attached to the proximal sheet **34**, surrounding the aperture **36** of the proximal sheet **34**. The pouch ring **40** comprises an adhesive coating **42** on the pouch ring **40**. The pouch ring **40** also comprises third and fourth loops **44, 46** extending radially from the pouch ring **40**. The body flange **14** and ostomy pouch **32** are configured for the third and fourth loops **44, 46** to engage within the pocket **28** of the first and second loops **22, 24**, respectively, the pouch ring **40** to fit around the flange ring **18**, and the rim **20** of the flexible plastic member **16** to contact the adhesive coating **42** on the pouch ring **40**, for assembly of the ostomy appliance **12**. The adhesive skin barrier member **30** has a multi-petaled outer perimeter **48** that has a shape corresponding to 2 to 8 petals **50** extending radially from the adhesive skin barrier member **30**, distributed uniformly around the adhesive skin barrier member **30**, and separated by notches **52** that expand radially from the adhesive skin barrier member **30**.

[0108] The method comprises a step of (0) cutting a stoma inlet portal **76** through at least the adhesive skin barrier member **30**, such that the flexible plastic member **16** and the adhesive skin barrier member **30** each have a stoma inlet portal **74, 76**, respectively centrally positioned and extending therethrough. The method also comprises a step of (1) placing the adhesive skin barrier member **30** at the peristomal region of the ostomate, such that the stoma inlet portals **74, 76** of the flexible plastic member **16** and the adhesive skin barrier member **30** are aligned with a stoma of the ostomate. The method also comprises a step of (2) engaging the third loop **44** with the pocket **28** of the first loop **22**. The method also comprises a step of (3) fitting the pouch ring **40** around the flange ring **18**. The method also comprises a step of (4) engaging the fourth loop **46** with the pocket **28** of the second loop **24**. The method also comprises a step of (5) contacting the rim **20** of the flexible plastic member **16** to the adhesive coating **42** on the pouch ring **40**. In accordance with the method, the ostomy appliance **12** is thereby adhered to the ostomate at the peristomal skin surface of the ostomate.

[0109] In accordance with some examples, the mounting assembly further comprises a first removable protective film **68** covering the adhesive skin barrier member **30**, and a second removable protective film **70** covering the adhesive coating **42** on the pouch ring **40**. In accordance with these examples, the method further comprises a step of removing the first

removable protective film **68** from the adhesive skin barrier member **30** prior to steps (0) and (1), and a step of removing the second removable protective film **70** from the adhesive coating **42** on the pouch ring **40** prior to steps (2) to (5).

[0110] Also in accordance with some examples, the ostomy appliance **12** adheres to the ostomate at the peristomal skin surface of the ostomate with a smooth fit.

[0111] Also in accordance with some examples, the ostomy appliance **12** adheres to the ostomate at the peristomal skin surface of the ostomate without application of adhesive tape to the ostomy appliance **12** or to the ostomate.

[0112] In accordance with some examples, the flexible plastic member **16** further comprises a central dome **56**.

[0113] Also in accordance with some examples, the body flange **14** further comprises (a) a first double-sided adhesive substrate member **58** adhered to the flexible plastic member **16** opposite the flange ring **18**, and having a size smaller than the multi-petaled outer perimeter **48** of the adhesive skin barrier member **30**, and (b) a second double-sided adhesive substrate member **60** adhered to the first double-sided adhesive substrate member **58** and the adhesive skin barrier member **30** and having a multi-petaled outer perimeter **49** that substantially corresponds in size and shape to the multi-petaled outer perimeter **48** of the adhesive skin barrier member **30**.

[0114] Also in accordance with some examples, the 2 to 8 petals **50** each have a width that first increases, then decreases, radially outwardly from the adhesive skin barrier member **30**.

[0115] Also in accordance with some examples, the adhesive skin barrier member **30** has a maximum radius **66**, and at least 50% of the multi-petaled outer perimeter **48** of the adhesive skin barrier member **30** extends to the maximum radius **66** of the adhesive skin barrier member **30**.

[0116] Also in accordance with some examples, the shape of the multi-petaled outer perimeter **48** of the adhesive skin barrier member **30** corresponds to 3 to 6 petals **50**.

[0117] Also in accordance with some examples, the rim **20** of the flexible plastic member **16** is substantially annular.

[0118] Also in accordance with some examples, the first and second loops **22**, **24** are diametrically opposed, and the third and fourth loops **44**, **46** are diametrically opposed.

[0119] Also in accordance with some examples, the adhesive skin barrier member **30** comprises an elastomer hydrocolloid mixture.

[0120] Also in accordance with some examples, the mounting assembly further comprises a

first removable protective film 68 covering the adhesive skin barrier member 30, and a second removable protective film 70 covering the adhesive coating 42 on the pouch ring 40.

[0121] Also in accordance with the method, the ostomy appliance 12 can be disassembled, to separate the ostomy pouch 32 from the body flange 14, e.g. to replace the ostomy pouch 32 as used with an ostomy pouch 32 that has not yet been used, as described above. Thus, in some examples, the rim 20 of the flexible plastic member 16 further comprises a tab 80 extending axially therefrom, and the pouch ring 40 also further comprises a tab 82 extending axially therefrom, and in accordance with these examples, the tab 80 of the flexible plastic member 16 and the tab 82 of the pouch ring 40 can be used for disassembly of the ostomy appliance 12 as described above.

EXAMPLES

[0122] Comparisons of surface adhesion by multi-petaled body flanges for a mounting assembly for an ostomy appliance versus circular (i.e. non-multi-petaled) body flanges for a mounting assembly for an ostomy appliance were carried out. The comparisons involved the following steps. First, a multi-petaled body flange and a circular body flange were applied to a curved surface of an object, such that most of each body flange was pressed by hand to the curved surface. Next, it was observed whether the application of each body flange had been accomplished with a smooth fit or whether undesirable bunching had occurred. Then the object was kept at approximately 24 °C for approximately 24 hours. Finally, it was observed whether peeling of either of the body flanges from the curved surface of the object had occurred where each body flange had been pressed by hand to the curved surface.

[0123] Two objects were used, a ball and a vase. The ball had a curved surface corresponding to a round surface. The vase had a curved surface corresponding to a convex surface. The curved surfaces were analogous to peristomal skin surfaces of ostomates, such as, for example, a curved abdominal surface associated with an ostomate who is overweight and, also for example, a curved abdominal surface associated with an ostomate who is bending at the waist. The multi-petaled body flanges and the circular body flanges both included the same adhesive, corresponding to an elastomer hydrocolloid mixture that is used commercially on body flanges of ostomy appliances. The adhesive is not specific to skin and would be expected to accomplish adhesion similarly for the ball and the vase as for skin.

[0124] For these comparisons, surface adhesion by the multi-petaled body flanges and the circular body flanges was tested without ostomy pouches attached to the body flanges. This was because the comparisons were focused on adhesion of the body flanges to the curved surfaces of the ball and the vase, and attachment of ostomy pouches to the body flanges would have obscured views of the body flanges as adhered to the curved surfaces.

[0125] Results of four comparisons are shown in FIG. 8, FIG. 9, FIG. 10, and FIG. 11.

[0126] In a first comparison, following application of a multi-petaled body flange and a circular body flange to the curved surface of the ball, such that most of each body flange was pressed by hand to the curved surface, it was observed that application of the multi-petaled body flange had been accomplished with a smooth fit (FIG. 8A, left side, top half), whereas undesirable bunching had occurred upon application of the circular body flange (FIG. 8A, right side, top half). Also, after the ball had been kept at approximately 24 °C for approximately 24 hours, it was observed that no peeling of the multi-petaled body flange from the ball had occurred where the multi-petaled body flange had been pressed by hand to the curved surface (FIG. 8B, right side, top half), whereas peeling of the circular body flange from the ball had occurred where the circular body flange had been pressed by hand to the curved surface (FIG. 8B, left side, top half).

[0127] Similarly, in a second comparison, following application of a multi-petaled body flange and a circular body flange to the curved surface of the vase, such that most of each body flange was pressed by hand to the curved surface, it was observed that application of the multi-petaled body flange had been accomplished with a smooth fit (FIG. 9A, left side, top half), whereas undesirable bunching had occurred upon application of the circular body flange (FIG. 9A, right side, top half). Also, after the vase had been kept at approximately 24 °C for approximately 24 hours, it was observed that no peeling of the multi-petaled body flange from the vase had occurred where the multi-petaled body flange had been pressed by hand to the curved surface (FIG. 9B, left side, top half), whereas peeling of the circular body flange from the vase had occurred where the circular body flange had been pressed by hand to the curved surface (FIG. 9B, right side, top half).

[0128] Similar results were obtained in a third comparison as in the first comparison. It was observed that application of the multi-petaled body flange had been accomplished with a smooth fit (FIG. 10A, right side, top half), whereas undesirable bunching had occurred upon application of the circular body flange (FIG. 10A, left side, top half). Also, after approximately 24 hours, it was observed that no peeling of the multi-petaled body flange from the ball had occurred where the multi-petaled body flange had been pressed by hand to the curved surface (FIG. 10B, right side, bottom half), whereas peeling of the circular body flange from the ball had occurred where the circular body flange had been pressed by hand to the curved surface (FIG. 10B, left side, top half).

[0129] Similar results also were obtained in a fourth comparison as in the second comparison. It was observed that application of the multi-petaled body flange had been accomplished with a smooth fit (FIG. 11A, left side, top half), whereas undesirable bunching had occurred upon application of the circular body flange (FIG. 11A, right side, top half). Also, after approximately 24 hours, it was observed that no peeling of the multi-petaled body flange from the vase had occurred where the multi-petaled body flange had been pressed by hand to the curved surface (FIG. 11B, left side, top half), whereas peeling of the circular body flange from the vase had occurred where the circular body flange had been pressed by hand to the curved surface (FIG. 11B, right side, top half).

[0130] The results demonstrate that a multi-petaled body flange of a mounting assembly for an ostomy appliance can adhere to curved surfaces analogous to peristomal skin surfaces of ostomates with a smooth fit, without undesirable bunching upon application and across a range of surface contours, consistent with an ostomy appliance comprising the multi-petaled body flange doing the same. The results also demonstrate that a multi-petaled body flange can adhere to curved surfaces analogous to peristomal skin surfaces of ostomates without application of adhesive tape to the multi-petaled body flange or the curved surfaces, such that no adhesive tape needs to be applied to smooth, press, or adhere the body flange to the surface and across a range of surface contours, also consistent with an ostomy appliance comprising the multi-petaled body flange doing the same. Based on these results, it is believed that the multi-petaled body flange can provide longer wear times relative to the circular body flange, e.g. wear times of 3 to 5 days versus wear times of several hours to half of a day, particularly as a corresponding ostomy pouch fills with body waste and the weight of the ostomy pouch thus increases.

INDUSTRIAL APPLICABILITY

[0131] The mounting assembly for an ostomy appliance disclosed herein is useful for collection of waste from surgically diverted organs of ostomates.

REFERENCES CITED IN THE DESCRIPTION

Cited references

This list of references cited by the applicant is for the reader's convenience only. It does not form part of the European patent document. Even though great care has been taken in compiling the references, errors or omissions cannot be excluded and the EPO disclaims all liability in this regard.

Patent documents cited in the description

- [US6790200B](#) **[0003]**
- [US8328779B](#) **[0004]**
- [US2014114265A](#) **[0005]**
- [WO2015180731A](#) **[0006]**
- [EP0882437A](#) **[0007]**
- [GB2311467A](#) **[0008]**

- JPH10248867B [0010]

Patentkrav

1. Monteringsanordning til en stomiindretning (12), omfattende:

(a) en legemeflange (14) omfattende:

5 (i) et fleksibelt plastelement (16) placeret på en første side af legemeflengen (14), idet det fleksible plastelement (16) omfatter en flangering (18), som rager aksialt ud fra legemeflengen (14), en rand (20) som omgiver flangeringen (18), og første og anden sløjfer (22, 24) som strækker sig radialt fra randen (20), idet hver af de første og anden sløjfer (22, 24) omfatter en hævet indramning (26) omkring en åbning, som
10 danner en lomme (28), og

(ii) et klæbende hudbarriereelement (30) placeret på en modsat anden side af legemeflengen (14), og

(b) en stomipose (32) omfattende:

15 (i) en proksimal flade (34) med en åbning (36),
(ii) en distal flade (38) tætnet på den proksimale flade (34) ved deres respektive omkredse for at danne stomiposen (32), og
(iii) en posering (40) fastgjort til den proksimale flade (34), som omslutter åbningen af den proksimale flade (34), idet poseringen (40) omfatter en klæbende belægning (42) på poseringen (40), og tredje og fjerde sløjfer (44, 46) som strækker sig radialt fra poseringen (40),
20

hvor:

legemeflengen (14) og stomiposen (32) er konfigureret for de tredje og fjerde sløjfer (44, 46) til at gå i indgreb inden i lommen (28) af henholdsvis de første og anden sløjfer (22, 24), poseringen (40) til at passe omkring flangeringen (18), og randen (20) af det fleksible plastelement (16) til at
25 komme i kontakt med den klæbende belægning (42) på poseringen (40), til montering af stomiindretningen (12),

kendetegnet ved, at: det klæbende hudbarriereelement (30) har en flerbladet ydre omkreds (48), som har en form svarende til 2 til 8 blade (50), som strækker sig radialt fra det klæbende hudbarriereelement (30),
30 fordelt ensartet omkring det klæbende hudbarriereelement (30), og adskilt af indsnit (52), som udvider sig radialt fra det klæbende hudbarriereelement (30), hvor

hver af de 2 til 8 blade (50) vinkelformet krydser hvert tilstødende blad (50), for derved at definere indsnittene (52), og de 2 til 8 blade (50) hver har en bredde (64), som først stiger, derefter falder, radialt udad fra det klæbende hudbarriereelement (30).

5

2. Monteringsanordningen ifølge krav 1, hvor det fleksible plastelement (16) yderligere omfatter en central kuppel (56).

3. Monteringsanordningen ifølge krav 1, hvor legemeflangeren (14) yderligere omfatter:

10

(a) et første dobbeltsidet klæbende substratelement (58) klæbet på det fleksible plastelement (16) modsat flangeringen (18), og med en størrelse som er mindre end den flerbladede ydre omkreds (48) af det klæbende hudbarriereelement (30), og

15

(b) et andet dobbeltsidet klæbende substratelement (60) klæbet på det første dobbeltsidede klæbende substratelement (58) og det klæbende hudbarriereelement (30) og med en flerbladet ydre omkreds (49), som i alt væsentligt i størrelse og form svarer til den flerbladede ydre omkreds (48) af det klæbende hudbarriereelement (30).

20

4. Monteringsanordningen ifølge krav 1, hvor det klæbende hudbarriereelement (30) har en maksimal radius (66), og mindst 50% af den flerbladede ydre omkreds (48) af det klæbende hudbarriereelement (30) strækker sig den maksimale radius (66) af det klæbende hudbarriereelement (30).

25

5. Monteringsanordningen ifølge krav 1, hvor formen af den flerbladede ydre omkreds (48) af det klæbende hudbarriereelement (30) svarer til 3 til 6 blade (50).

6. Monteringsanordningen ifølge krav 1, hvor randen (20) af det fleksible plastelement (16) i alt væsentligt er ringformet.

30

- 7.** Monteringsanordningen ifølge krav 1, hvor de første og anden sløjfer (22, 24) er diametralt modsatte, og de tredje og fjerde sløjfer (44, 46) er diametralt modsatte.
- 5 **8.** Monteringsanordningen ifølge krav 1, hvor det klæbende hudbarriereelement (30) omfatter en elastomer-hydrokolloidblanding.
- 9.** Monteringsanordningen ifølge krav 1, yderligere omfattende en første aftagelig beskyttelsesfilm (68) som dækker det klæbende hudbarriereelement (30), og en
10 anden aftagelig beskyttelsesfilm (70) som dækker den klæbende belægning (42) på poseringen (40).
- 10.** Monteringsanordningen ifølge krav 1, hvor det fleksible plastelement (16) og
15 det klæbende hudbarriereelement (30) hver har en stomaindgangsportal (74, 76), som er centralt positioneret og strækker sig derigennem.
- 11.** Stomiindretning (12) omfattende monteringsanordningen ifølge krav 1, hvor legemeflangeren (14) og stomiposen (32) er i samlet indgreb baseret på de tredje og fjerde sløjfer (44, 46), som er i indgreb inden i lommen (28) af de henholdsvis
20 første og anden sløjfer (22, 24), idet poseringen (40) passer omkring flangeringen (18), og idet randen (20) af det fleksible plastelement (16) er i kontakt med den klæbende belægning (42) på poseringen (40).
- 12.** Monteringsanordningen ifølge krav 1, hvor formen af den flerbladede ydre
25 omkreds (48) af det klæbende hudbarriereelement (30) svarer til 4 blade (50).

DRAWINGS

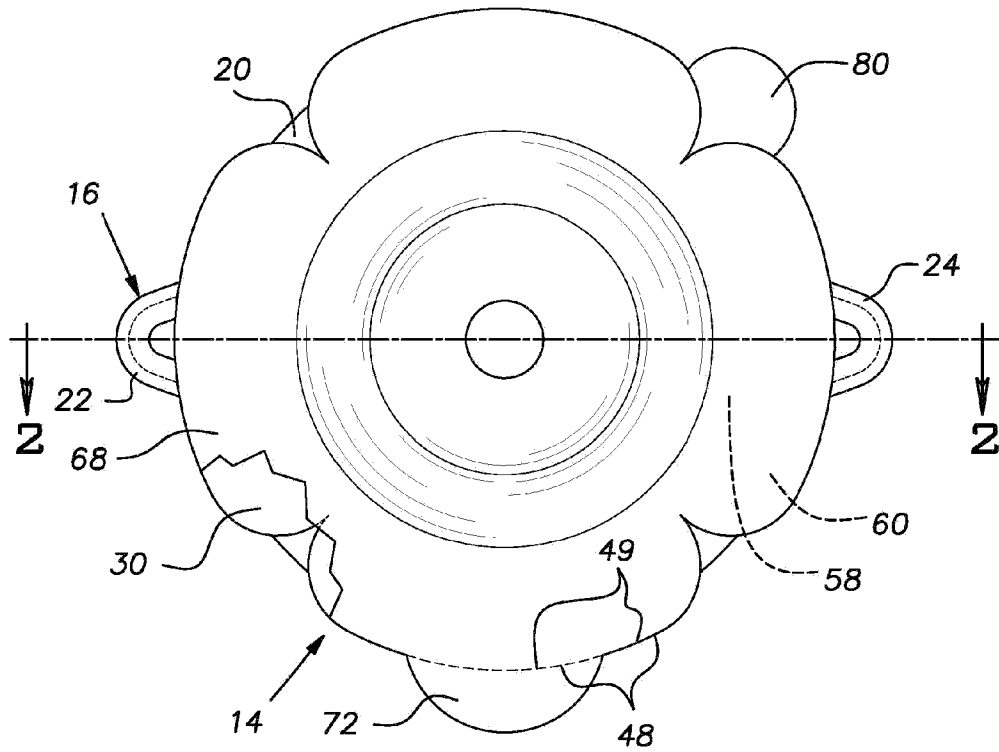

FIG. 1

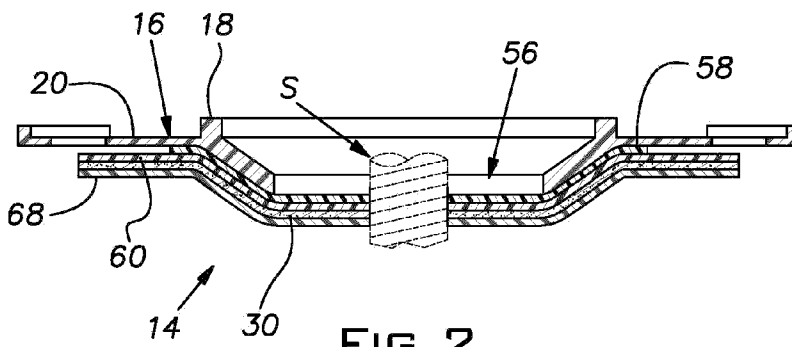

FIG. 2

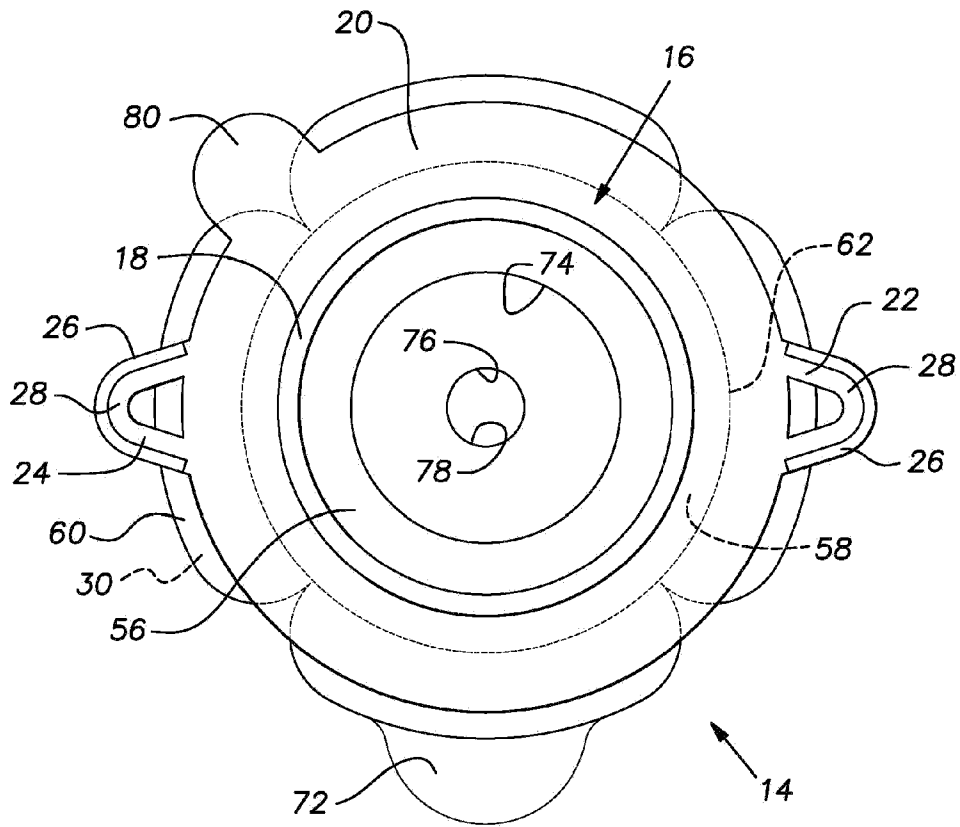

FIG. 3

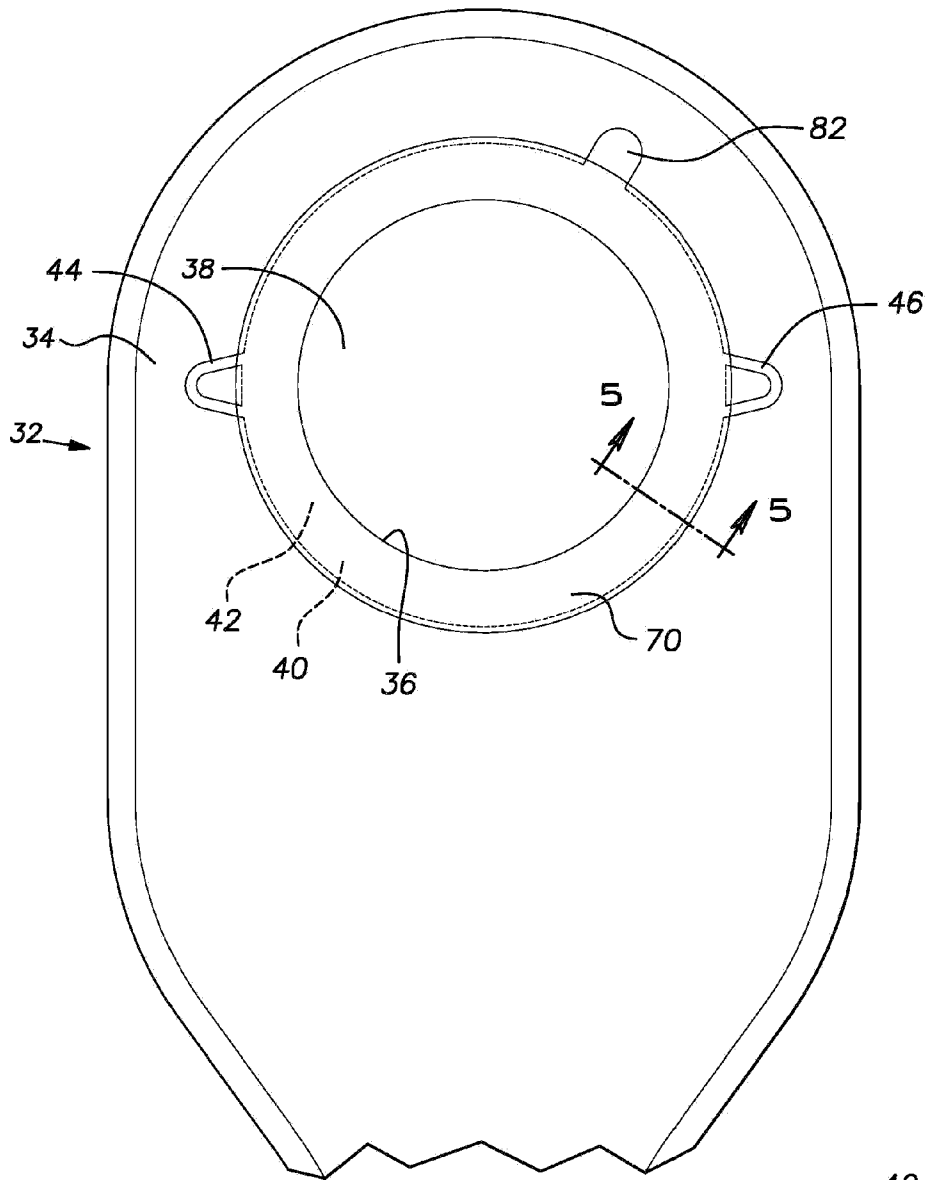

FIG. 4

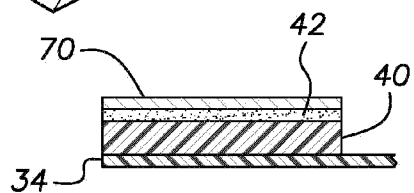

FIG. 5

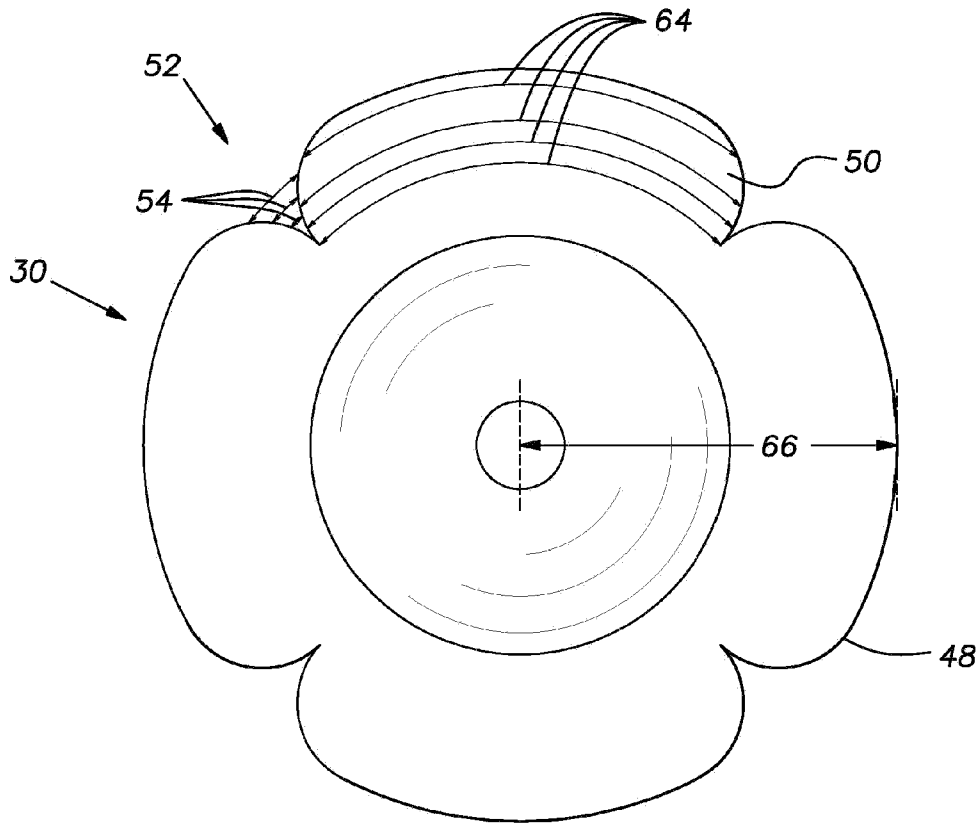

FIG. 6

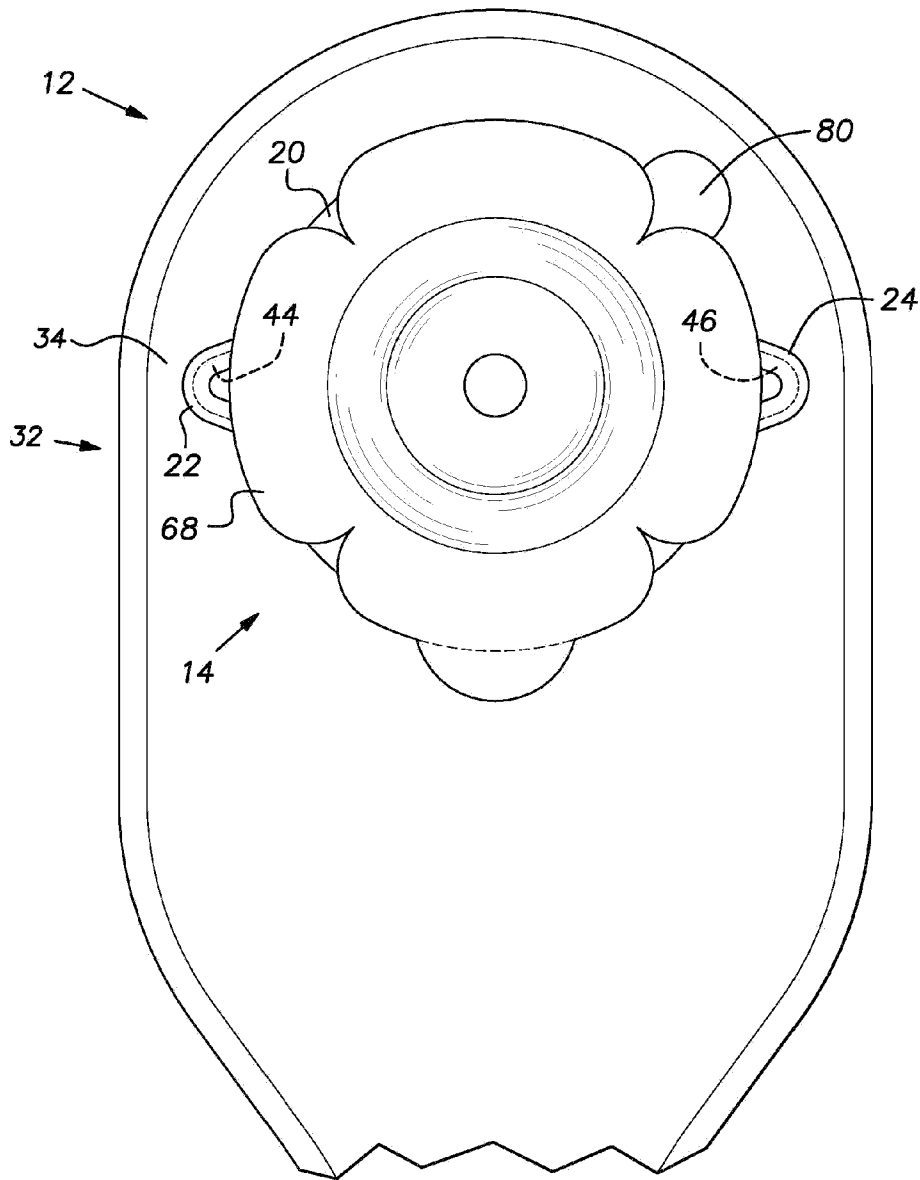

FIG. 7

A



B



FIG. 8

A



B

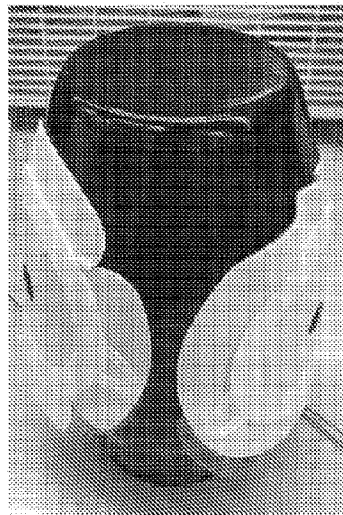
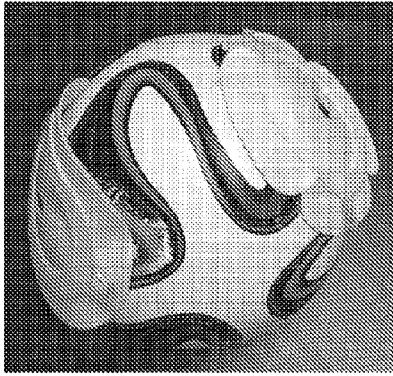

FIG. 9

A



B



FIG. 10

A

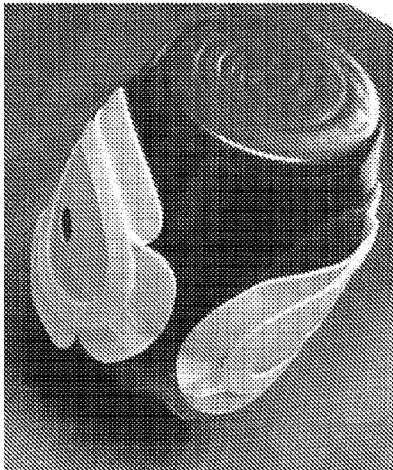

B

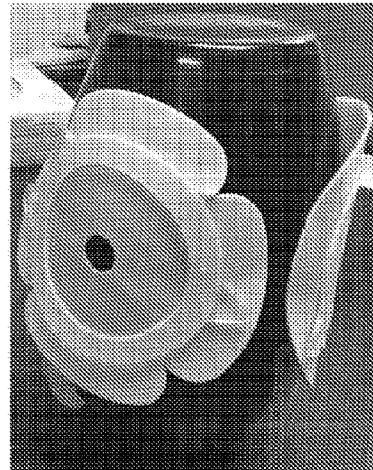

FIG. 11