

(19)
(12)

(KR)
(Y1)

(51) 。 Int. Cl. ⁷
A45D 29/11

(45)
(11)
(24)

2002 04 03
20 - 0270372
2002 03 19

(21) 20 - 2001 - 0032977
(22) 2001 10 29

(73) 276 - 1

(72) 251

(74)
:

가 :

(54)

가

가

- 1 .
- 2 .
- 3 .
- 4 .
- 5 .

- 100 :
- 110 :
- 112 :
- 114 :
- 116 :
- 120 :

1 , (1) 가 가 (3) .

가

2 , 3 .

(114) (116) (110) (112) (120) (122) ,
(120) (120) (110)

4 .
(112) .

5 .
(112) 가 ,

가 . ,

(57)

1.

가 ;

2.

1 ,

3.

1 2 ,

4.

1 ,

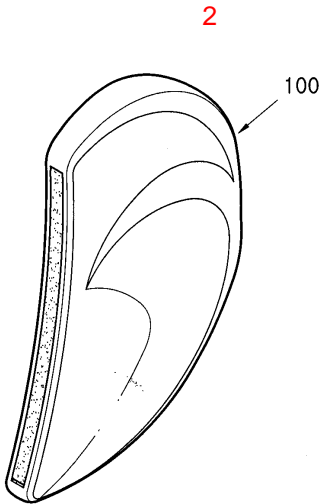
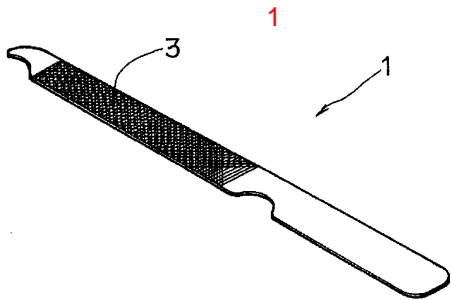

3

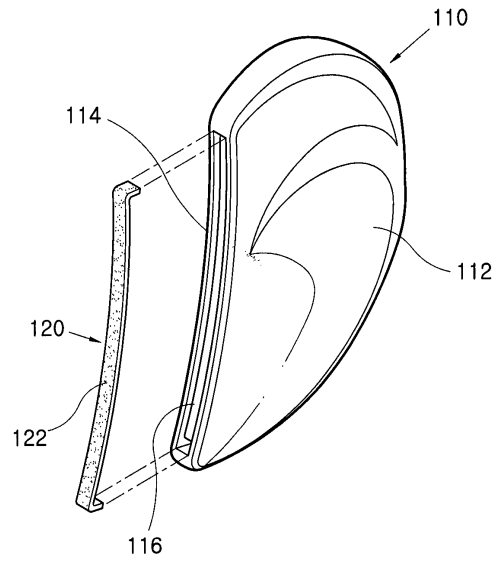

4

