



US 20100279785A1

(19) **United States**

(12) **Patent Application Publication**  
**Oldknow et al.**

(10) **Pub. No.: US 2010/0279785 A1**

(43) **Pub. Date: Nov. 4, 2010**

(54) **ANGLE ADJUSTMENT FEATURES FOR GOLF CLUBS**

**Publication Classification**

(51) **Int. Cl.**  
*A63B 53/06* (2006.01)

(76) Inventors: **Andrew G.V. Oldknow**, Beaverton, OR (US); **Michael E. Finn**, Fort Worth, TX (US)

(52) **U.S. Cl.** ..... **473/282; 473/349**

(57) **ABSTRACT**

Correspondence Address:  
**BANNER & WITCOFF, LTD.**  
**28 STATE STREET, SUITE 1800**  
**BOSTON, MA 02109-1701 (US)**

A golf club having a golf club shaft and a golf club head is provided. The shaft includes a proximal end, a distal end, and a longitudinal axis extending therebetween. The golf club head, which is attached to the distal end of the golf club shaft, extends from a heel region to a toe region and from a front surface to a back surface. The golf club head includes an angle adjustment void structure that is located below the distal end of the golf club shaft. The angle adjustment void structure may include a cavity formed in the back surface, the depth dimension of the cavity extending from the back surface toward the front surface. The cavity, when viewed from the back surface, may be aligned with the longitudinal axis.

(21) Appl. No.: **12/432,133**

(22) Filed: **Apr. 29, 2009**

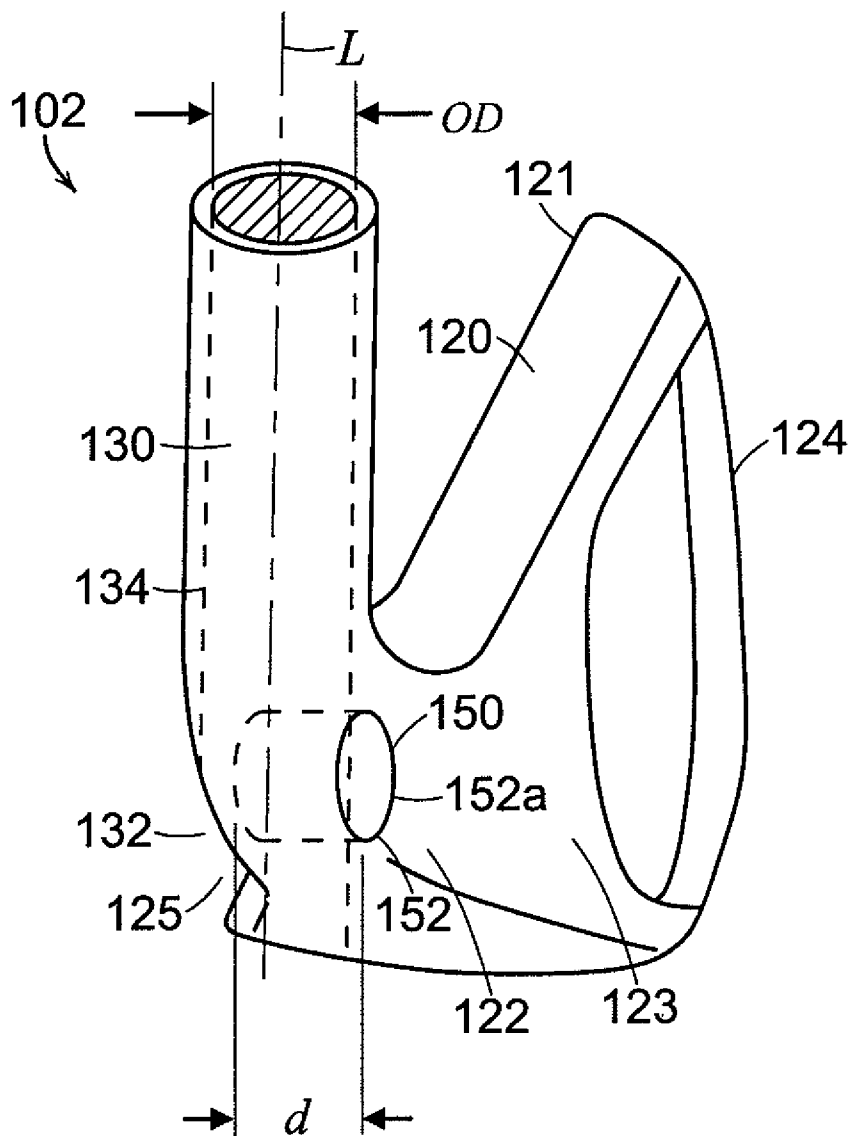

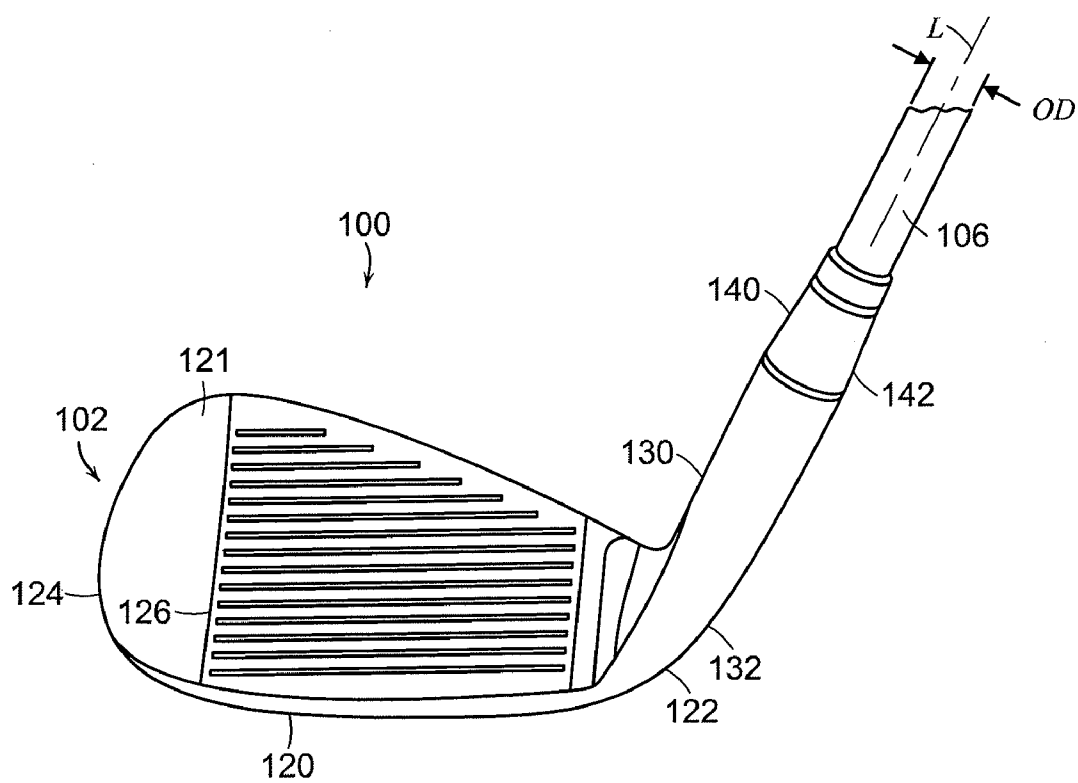

FIG. 1

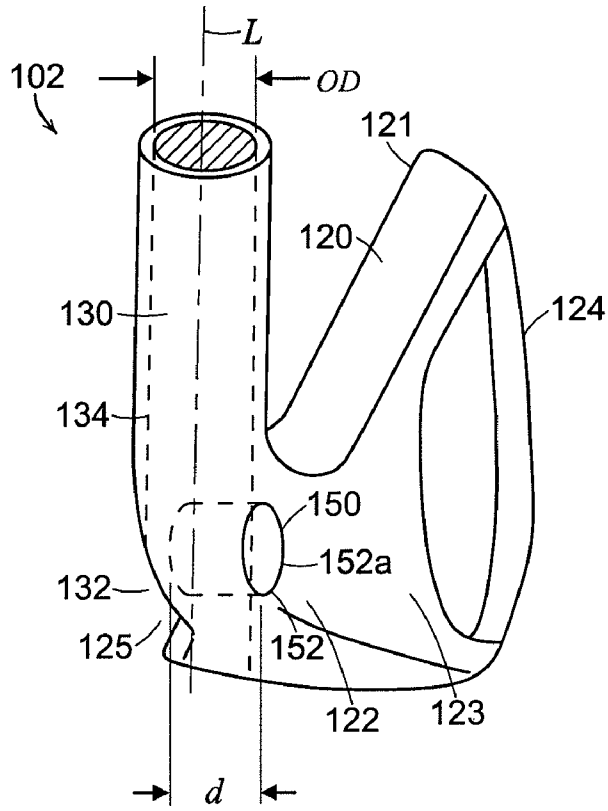

FIG. 2

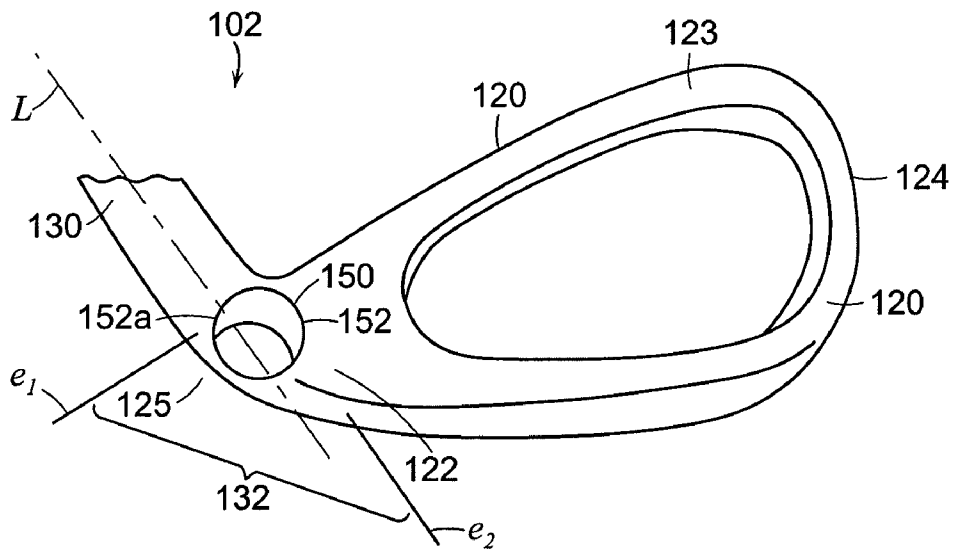

FIG. 3

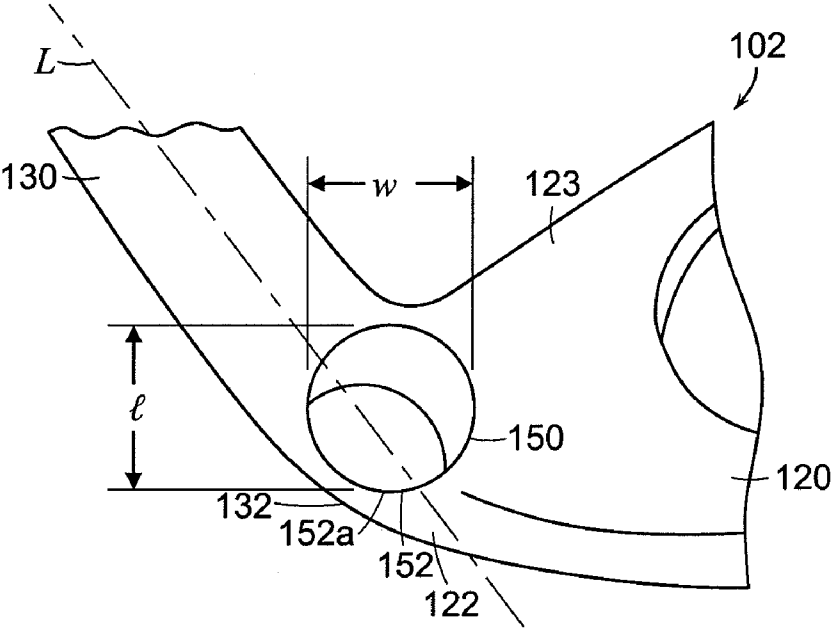

FIG. 4A

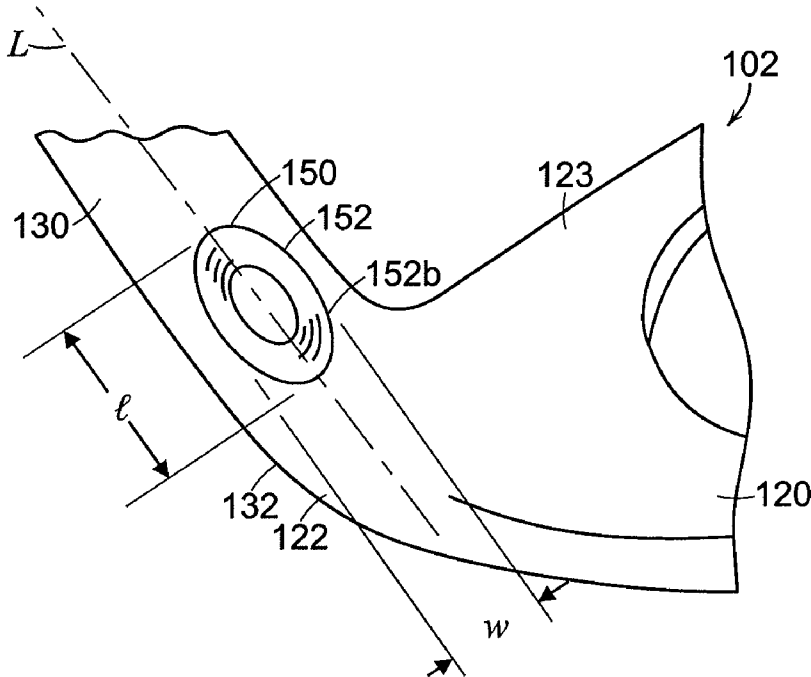

FIG. 4B

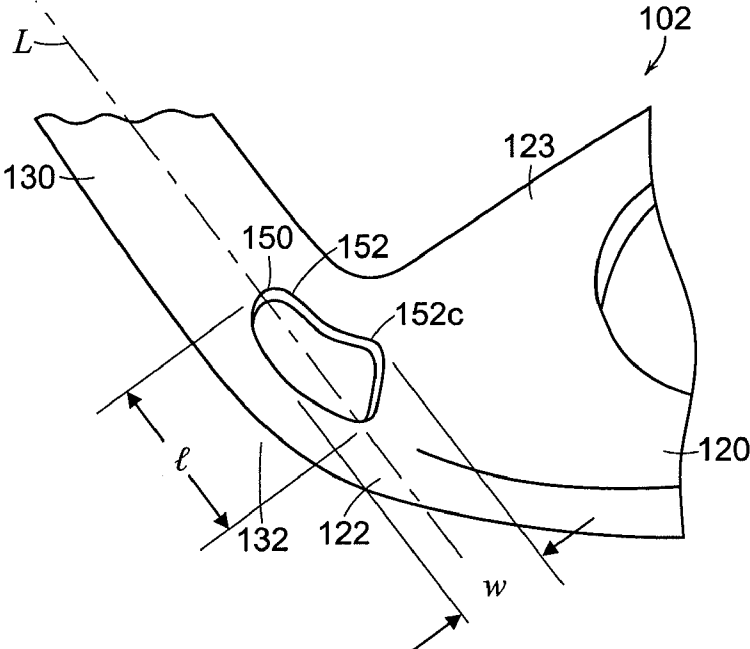

FIG. 4C

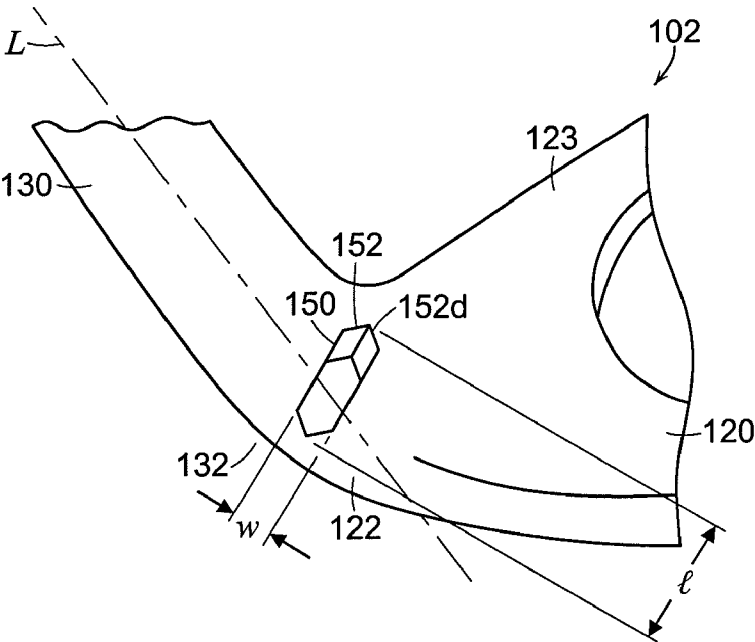

FIG. 4D

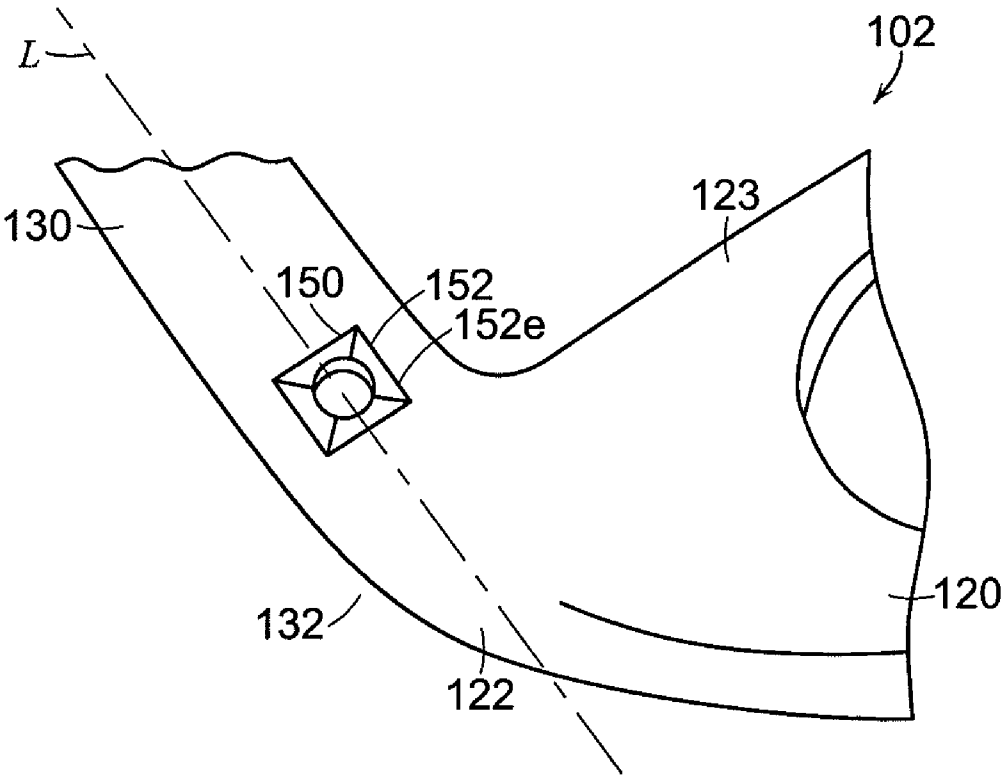

FIG. 4E

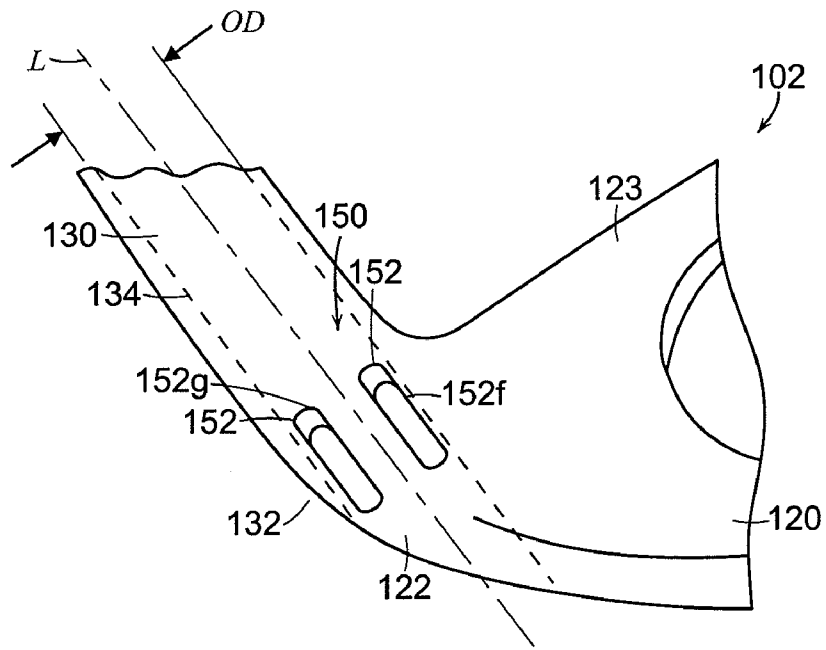

FIG. 5A

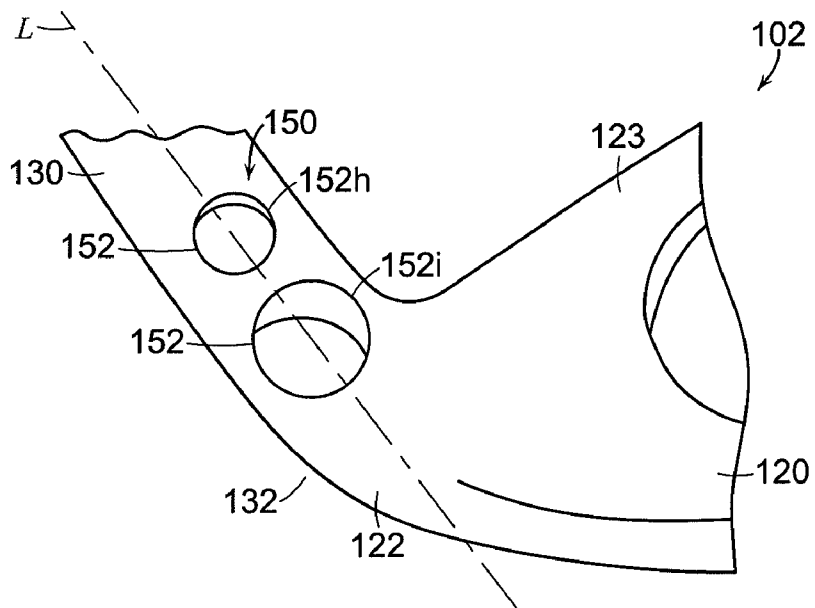

FIG. 5B

## ANGLE ADJUSTMENT FEATURES FOR GOLF CLUBS

### FIELD OF THE INVENTION

**[0001]** This invention relates generally to golf clubs and golf club heads. More particularly, aspects of this invention relate to golf clubs having angle adjustment features.

### BACKGROUND

**[0002]** Golf is enjoyed by a wide variety of players—players of different genders and dramatically different ages and/or skill levels. Golfers at all skill levels seek to improve their performance, lower their golf scores, and reach that next performance “level.” One way to improve performance is to use more technologically advanced equipment. A further way to improve performance is to select equipment that matches an individual golfer’s style.

**[0003]** Golf clubs have been the subject of much technological research and advancement in recent years. Certain technological advancements have been made in an effort to better match the various elements and/or characteristics of the golf club and characteristics of a golf ball to a particular user’s swing characteristics (e.g., club fitting technology, ball launch angle measurement technology, ball spin rates, etc.). There now exists a vast array of golf club component parts available to the golfer. For example, individual club head models may include variations in the loft angle, lie angle, offset features, weighting characteristics, etc. These various club heads may be combined with a variety of shafts having, for example, any of various stiffnesses, flex points, kick points or other flexion characteristics. Between the available variations in shafts and club heads, there are literally hundreds of different club head/shaft combinations available to the golfer.

**[0004]** Club fitters and golf professionals can assist in fitting golfers with a golf club head/shaft combination that suits their swing characteristics and needs. Not only should the individual golf head and shaft be selected based on the specific golfer’s swing characteristics, but the angle at which the shaft is fitted to the head, i.e. the lie angle, should also be matched to the individual golfer’s physical characteristics.

**[0005]** The lie angle is the angle between the center line of the hosel and the sole of the club head when the sole is touching the ground at the center of the face scoring area. If the center of the face scoring area of the club head is on the ground when a golfer stands at address then the lie of the club is generally considered perfect—this is termed a “standard” lie. If the toe of the club head points in the air and the heel of the club head is on the ground, then the golfer’s lie is too “upright” and should be made flatter. In contrast, if the heel of the club head is in the air and the toe is on the ground, then the golfer’s lie is too “flat” and should be made more upright. Shorter players generally use a flatter lie angle; taller players generally use a more upright lie angle.

**[0006]** The lie of the club can have a significant impact on ball flight. If the lie is too flat for a particular golfer, the toe of the club head may impact the ground first and the ball flight may tend to move from the inside outward. If the lie of the club is too upright for the golfer, the ball flight may tend to move from the outside inward. Conventionally, shafts are mounted to golf club heads using hosels. In some instances, custom-fitting of golf clubs to an individual golfer has involved bending the hosel to provide the correct lie angle for

that golfer/club combination. However, the hosel, which is a structural connection between the shaft and the club head, may have material properties that are not amenable to bending. Thus, for example, wrinkles, bulges, stress concentrations, cracks, or other defects may result from the application of the bending forces. Further, bending may result in an attendant loss of strength and/or stiffness.

**[0007]** The disadvantages associated with conventional structures associated with adjusting a club’s lie angle may limit the amount of adjustment and/or reduce the technical performance of the golf club.

### SUMMARY

**[0008]** The following presents a general summary of aspects of the disclosure in order to provide a basic understanding of the invention and various features of it. This summary is not intended to limit the scope of the invention in any way, but it simply provides a general overview and context for the more detailed description that follows.

**[0009]** In accordance with illustrative aspects of the disclosure, a golf club may include a golf club head having an angle adjustment void structure that is located below a distal end of the golf club shaft. The angle adjustment void structure may include a cavity formed in the back surface. The depth dimension of the cavity may extend from the back surface of the club head toward the front surface of the club head. Further, the cavity, when viewed from the back surface, may be aligned with the longitudinal axis.

**[0010]** According to other aspects of this disclosure, a golf club includes a golf club head attached to the distal end of a golf club shaft. The golf club head includes a front surface, a back surface, and a longitudinal axis region defined by projecting the outer diameter of the golf club shaft along an extension of the longitudinal axis. An angle adjustment void structure may be located below the distal end of the golf club shaft. The angle adjustment void structure may include a cavity formed in the back surface and located at least partially in the longitudinal axis region.

**[0011]** According to certain aspects of this disclosure, a golf club head includes a connection region configured for attachment to a distal end of a golf club shaft. The connection region defines a longitudinal axis. The golf club head further includes a main body extending from a heel region to a toe region and a neck region extending from the heel region to a connection region. An angle adjustment void structure may be located below the connection region. The angle adjustment void structure may include a cavity formed in a back surface of the club head and having a depth dimension extending from the back surface toward the front surface of the club head. The cavity may be at least partially located within a 10 mm radius of the longitudinal axis.

**[0012]** In accordance with still other aspects of the disclosure, a golf club may include a golf club head having a means for relieving strain that is located below a distal end of the golf club shaft. The means for relieving strain may include a void formed in the back surface. The depth dimension of the void may extend from the back surface of the club head toward the front surface of the club head. Further, the void, when viewed from the back surface, may be aligned with the longitudinal axis.



[0013] In accordance with additional illustrative aspects of the disclosure, a golf club may include a golf club shaft attached to a golf club head as provided above.

#### BRIEF DESCRIPTION OF THE DRAWINGS

[0014] A more complete understanding of the present invention and certain advantages thereof may be acquired by referring to the following detailed description in consideration with the accompanying drawings, in which:

[0015] FIG. 1 generally illustrates a front view of a portion of an example golf club according to an aspect of this disclosure;

[0016] FIG. 2 generally illustrates a heel-side view of a portion of an example golf club head according to an aspect of this disclosure;

[0017] FIG. 3 generally illustrates a back view of a portion of an example golf club head in accordance with this disclosure and the aspect of FIG. 2;

[0018] FIG. 4A generally illustrates an enlarged view of a portion of FIG. 3;

[0019] FIG. 4B generally illustrates an enlarged back view of a portion of an example golf club head according to an aspect of disclosure;

[0020] FIG. 4C generally illustrates an enlarged back view of a portion of an example golf club head according to another aspect of disclosure;

[0021] FIG. 4D generally illustrates an enlarged back view of a portion of an example golf club head according to yet another aspect of disclosure;

[0022] FIG. 4E generally illustrates an enlarged back view of a portion of an example golf club head according to still another aspect of disclosure;

[0023] FIG. 5A generally illustrates an enlarged back view of a portion of an example golf club head according to a further aspect of disclosure; and

[0024] FIG. 5B generally illustrates an enlarged back view of a portion of an example golf club head according to still a further aspect of disclosure.

[0025] The reader is advised that the attached drawings are not necessarily drawn to scale and that certain features may have been exaggerated in or removed from the drawings for purposes of discussion.

#### DETAILED DESCRIPTION

[0026] In the following description of various example structures in accordance with the disclosure, reference is made to the accompanying drawings, which form a part hereof, and in which are shown by way of illustration various example connection assemblies, golf club heads, and golf club structures in accordance with the disclosure. Additionally, it is to be understood that other specific arrangements of parts and structures may be utilized and structural and functional modifications may be made without departing from the scope of the present invention. Also, while the terms “top,” “bottom,” “front,” “back,” “rear,” “side,” “underside,” “overhead,” and the like may be used in this specification to describe various example features and elements of the disclosure, these terms are used herein as a matter of convenience, e.g., based on the example orientations shown in the figures and/or the orientations in typical use. Nothing in this specification should be construed as requiring a specific three dimensional or spatial orientation of structures in order to fall within the scope of this invention.

[0027] A. General Description of Golf Club Angle Adjustment Features and Golf Clubs Including Such Features According to Examples of the Disclosure

[0028] In general, as described above, aspects of this disclosure relate to features for adjusting the lie and/or loft angles of golf clubs so that the club heads and shafts can be oriented at various angles with respect to one another. More detailed descriptions of aspects of this disclosure follow.

[0029] Illustrative aspects of this disclosure relate to features provided on golf club heads so that any of various lie and/or loft angles of a golf club shaft with respect to the club head body (and its ball striking face) can be readily achieved. The angle of a golf club shaft may be adjusted with respect to a golf club head body by deforming a portion of the club head. Generally, the deformation occurs as a result of bending stresses experienced in a bend region or at a bendline located between the distal end of the golf club shaft and body of the golf club head. Aspects of this disclosure relate to reducing stresses, strains and/or deformations in the bend region, that arise due to the angle of a club shaft to a club head being changed, by providing a means for relieving strains and/or stresses. A means for relieving these strains may include an angle adjustment void structure on the club head. An angle adjustment void structure may include one or more void-like, cavity-like or other hole-like or gap-forming elements wherein an opening in the surface disrupts the material continuity of the golf club head. The means for relieving strains may relieve or ameliorate strains in the bend region in both the longitudinal and the transverse directions. Further, the means for relieving strains may relieve stress concentrations and reduce the likelihood that wrinkles and or cracks may develop in the bend region.

[0030] 1. Example Angle Adjustment Features and Golf Club Structures

[0031] A golf club having a golf club shaft and a golf club head is provided. The shaft includes a proximal end, a distal end, and a longitudinal axis extending therebetween. The golf club head, which is attached to the distal end of the golf club shaft, extends from a heel region to a toe region. The golf club head may include an angle adjustment void structure that is located below the distal end of the golf club shaft. The angle adjustment void structure may include a void or a cavity formed in the back surface. The depth dimension of the void or cavity may extend from the back surface toward the front surface. Further, the void or cavity, when viewed from the back surface, may be aligned with the longitudinal axis.

[0032] According to certain aspects, the angle adjustment void structure may include a cavity extending over both transverse and longitudinal directions, with respect to the longitudinal axis defined by the golf club shaft. When the angle between the shaft and the club head body is adjusted, bending occurs in a bend region below the distal end of the shaft in the neck and/or heel region of the club head. On one side of the bend region, the material of the club head is stretched (or placed in tension) and on the other side of the bend region, the material of the club head is squashed (or placed in compression). When a material is compressed in a first direction, it tends to want to expand in a direction perpendicular to the first direction. Similarly, when a material is stretched in a first direction, it tends to want to shrink in a direction perpendicular to the first direction. Thus, biaxial stresses and strains are developed in the bend region when the lie and/or loft angles

are adjusted. By providing an angle adjustment void having a cavity, these biaxial stresses and strains may be accommodated.

**[0033]** Because a cavity has a bottom surface that is coincident with the front surface of the club head, a web of material is available to provide stiffness and stability to the golf club head in the region where stresses and deformations may be at their maximum, i.e., in the bend region. Additionally, the cavity's bottom surface web of material connects the two regions (or "legs") on either side of the cavity, thereby forcing the legs to act in concert, at least on the front surface of the club head. In some aspects, the cavity's bottom surface might act as a shear web or as an anti-buckling element.

**[0034]** The angle adjustment void structure may be provided at least partially in a neck region of the club head. Optionally, the angle adjustment void structure may be provided at least partially in a heel region of the club head. In some aspects, the angle adjustment void structure may be symmetric with respect to an axis parallel to the longitudinal axis. In other aspects, the angle adjustment void structure may be symmetric with respect to an axis perpendicular to the longitudinal axis.

**[0035]** According to certain aspects of this disclosure, a golf club includes a golf club shaft having a proximal end, a distal end, and a longitudinal axis defined therebetween. The golf club further includes a golf club head attached to the distal end of the golf club shaft. The golf club head includes a front surface, a back surface, and a longitudinal axis region defined by projecting the outer diameter of the golf club shaft along an extension of the longitudinal axis. An angle adjustment void structure may be located below the distal end of the golf club shaft. The angle adjustment void structure may include a cavity formed in the back surface and located at least partially in the longitudinal axis region.

**[0036]** According to other aspects of this disclosure, a golf club head includes a connection region configured for attachment to a distal end of a golf club shaft. The connection region defines a longitudinal axis. The golf club head further includes a main body extending from a heel region to a toe region and a neck region extending from the heel region to a connection region. An angle adjustment void structure may be located below the connection region. The angle adjustment void structure may include a cavity formed in a back surface of the club head and having a depth dimension extending from the back surface toward the front surface of the club head. The cavity may be at least partially located within a 10 mm radius of the longitudinal axis.

**[0037]** Optionally, the angle adjustment void structure may include multiple cavities. These cavities may have a synergistic effect. For example, each cavity may relieve a portion of the biaxial bending stresses and strains. Further, multiple cavities may provide a more distributed relief feature. Even further, the multiple cavities may better accommodate the combined adjustment of the lie angle and adjustment of the loft angle. Unsightly wrinkles or other undesirable deformations at the bend region may be avoided.

**[0038]** A golf club having a golf club shaft and a golf club head is provided. The shaft includes a proximal end, a distal end, and a longitudinal axis extending therebetween. The golf club head, which is attached to the distal end of the golf club shaft, extends from a heel region to a toe region. The golf club head may include a means for relieving strain that is located below the distal end of the golf club shaft. The means for relieving strain may include a void formed in the back sur-

face. The depth dimension of the void may extend from the back surface toward the front surface. Further, the void, when viewed from the back surface, may be aligned with the longitudinal axis.

**[0039]** The angle adjustment void structures described herein can help keep the overall connection assembly relatively compact and lightweight, while facilitating lie and loft angle adjustment and maintaining rotational and bending stiffness.

**[0040]** Aspects of this disclosure relating to the angle adjustment features and to golf club structures that incorporate the angle adjustment features will be described in more detail below.

**[0041]** Specific examples of the disclosure are described in more detail below. The reader should understand that these specific examples are set forth merely to illustrate examples of the disclosure, and they should not be construed as limiting the disclosure.

**[0042]** B. Specific Examples of the Disclosure

**[0043]** FIGS. 1-3 generally illustrate example golf clubs **100** in accordance with at least certain aspects of this disclosure. FIGS. 4A through 4E and FIGS. 5A through 5B generally illustrate various embodiments of angle adjustment void structures according to aspects of this disclosure.

**[0044]** Referring to FIG. 1, the club **100** includes a club head **102** and a club shaft **106**. The club shaft **106** has a proximal end where a golfer grips the shaft (not shown), a distal end where the club head **102** is attached to shaft **106**, and a longitudinal axis (L) extending along the length of the shaft from the proximal to the distal end.

**[0045]** As shown in FIG. 1, the club head **102** includes a main body **120**, a neck **130** and a club head-to-shaft connection region **140**. The club head **102** may be attached to the distal end of the club shaft **106** at the club head-to-shaft connection region **140**. The club head-to-shaft connection region **140** may be provided by a hosel **142**. The club head-to-shaft connection region **140** may be defined as the region where the shaft **106** and the club head **102** overlap. In certain embodiments, the club head-to-shaft connection region **140** is that region where the distal end of the club shaft **106** and the hosel **142** overlap.

**[0046]** Referring to FIGS. 1 through 3, the club head **102** includes a main body **120** that extends from a heel region **122** to a toe region **124** in first direction and from a front surface **121** to a back surface **123** in a second direction. A ball-striking face member **126** may be provided on the front surface **121** of the main body **120**. Neck region **130** extends between the main body **120** and the club-head-to-shaft connection region **140**. The neck region **130** generally includes an elongated structure that extends generally in the same direction as the longitudinal axis L of the club shaft **106**. The main body **120** extends from the neck region **130** in a direction that is generally transverse to the direction of extension of the neck region **130**.

**[0047]** It is recognized that the demarcation between the heel region **122** of the main body **120** and the neck region **130** may not be clearly defined. Thus, referring to FIGS. 2 and 3, a transition region **132** may be defined where the neck region **130** and the heel region **122** merge. More specifically, referring to FIG. 3, the transition region **132** may include that portion of the club head **102** that is bounded by an extension  $e_1$  of the upper edge of main body **120** and an extension  $e_2$  of the club-side edge of the neck region. For some club head

configurations, the transition region 132 may include portions of the neck region 130 and/or the heel region 122.

[0048] Additionally, referring to FIG. 2, a longitudinal axis region 134 may be defined by projecting an outer diameter OD of the golf club shaft 106 along an extension of the longitudinal axis L. In other words, the longitudinal axis region 134 encompasses the portion of the club head 102 that is aligned with a projection of the golf club shaft 106. The longitudinal axis region 134 generally may extend through the neck region 130 and the transition region 132 of the club head 102. At least portions of this longitudinal axis region 134 may be expected to experience deformation upon adjusting the angle of the shaft 106 relative to the main body 120.

[0049] According to certain aspects of the present disclosure, a means for relieving strains is provided on the club head 102. Accordingly, an angle adjustment void structure 150 may be provided on the club head 102. The angle adjustment void structure 150 is located below the club head-to-shaft connection region 140. In other words, the angle adjustment void structure 150 is located distally beyond, i.e. distally below, the distal end of the golf club shaft. In certain aspects, the angle adjustment void structure 150 may be located in the neck region 130. In other aspects, the angle adjustment void structure 150 may be located in the transition region 132. In even other aspects, the angle adjustment void structure 150 may be located in the heel region 122. According to aspects of the present disclosure, the angle adjustment void structure 150 may be located on the back surface 123 of the club head 102.

[0050] The angle adjustment void structure 150 facilitates the adjustment of the angle (lie and/or loft) of the club shaft 106 relative to the club head 102. This angle of the club shaft 106 relative to the club head 102 may be adjusted by deforming (e.g., bending) the club head 102 at a bend region 125. The bend region 125 is located below the head-to-shaft connection region 140 and may be located in the neck region 130, the heel region 122, or the transition region 132. The angle adjustment void structure 150 may reduce bending stresses and reduce or eliminate undesirable deformations of the club head 102 when the angle of the club shaft 106 is changed. Further, the angle adjustment void structure 150 may assist in defining the location of the bend region 125.

[0051] A range of desired angle adjustments may be accommodated without departing from this disclosure. By way of non-limiting example, adjustments of at least 0.25 degrees, at least 0.5 degrees, at least 1 degree, at least 2 degrees, at least 4 degrees, or even at least 8 degrees may be accommodated by the angle adjustment void. In some example structures, the desired adjustment will be between 0.25 and 25 degrees, between 0.5 and 15 degrees, between 1 and 10 degrees, or even between 1 and 5 degrees.

[0052] The angle adjustment void structure 150 in accordance with some aspects of this disclosure will now be described in more detail with reference to FIGS. 2 through 5B.

[0053] As shown in FIGS. 2 and 3, the angle adjustment void structure 150 may include a cavity 152 formed on the back surface 123 and located partially in the neck region 130 and partially in the transition region 132. The term "cavity," as used herein, refers to a region having side surfaces and a bottom surface, such that the region is at least partially enclosed by the mass of the club head 102, wherein the material that forms the surrounding mass of the club head 102 is absent from the region. Thus, for example, a hole with a

bottom surface, i.e., a hole that is not a through hole, is a cavity. A cavity has a cross section (having length  $l$  and width  $w$  dimensions) and a depth  $d$ . The dimensions of the cross section may be constant or they may vary along the depth  $d$ . Similarly, the depth  $d$  may be constant or it may vary along the length  $l$  and/or the width  $w$  of the cross section. In general, a cavity may have any length-to-width ratio, any length-to-depth ratio, or any width-to-depth ratio.

[0054] In FIGS. 2 and 3, a cavity 152a having a circular cross section is illustrated. Cavity 152a has a constant circular cross section. The cross section opening extends over a transverse distance and over a longitudinal distance. A transverse distance is measured perpendicular to the longitudinal axis L of the club shaft 106. A longitudinal distance is measured in a direction that is aligned with the longitudinal axis L of the club shaft 106. Thus, according to certain aspects, the cross section of the cavity 152a may be oriented substantially transversely to the longitudinal axis L.

[0055] According to aspects of the present disclosure, FIGS. 4A through 4E illustrate cavities 152 having any of various cross section shapes. FIG. 4A shows a portion of FIG. 3, enlarged for clarity. In FIG. 4A, cavity 152a has a generally circular cross section. Each cavity 152 has a length  $l$  and a width  $w$  associated with the cross section and a depth  $d$  (as shown in FIG. 2) extending out of the plane of the cross section of the cavity 152. The length  $l$  is the cavity's longest cross-section dimension, as measured at the opening of the cavity 152 on the back surface 123; the width  $w$  is the cavity's cross-section dimension at the opening that is perpendicular to the length  $l$  dimension. In FIG. 4B, cavity 152b has a generally elliptical cross section. In FIG. 4C, the cavity 152c has a somewhat bean-like shape, with the edges of the cavity 152c being substantially parallel to the edges of the transition region 132. Thus, this cross sectional shape for the cavity 152c is, in part, determined by the profile of the club body 102. In FIG. 4D, cavity 152d has an irregular polygonal shape. In FIG. 4E, cavity 152e has a square shape at the surface opening. Thus it can be seen that the cross-sectional shape of the cavity 152 may be substantially circular, elliptical, rectangular, triangular, or any other suitable shape, whether regular or irregular. The length  $l$  of the cross-sectional opening of the cavity 152, as measured at the back surface 123, may range from 5 mm to 30 mm. A length  $l$  of greater than 10 mm, or greater than 15 mm, or even greater than 20 mm may be desirable. Similarly, the width  $w$  of the cross-sectional opening of the cavity 152 as measured at the back surface 123 may range from 2 mm to 20 mm. A width  $w$  of greater than 5 mm, or greater than 10 mm, or even greater than 15 mm may be desirable.

[0056] Further, according to certain aspects of the present disclosure, the cross section of the cavity 152 may have a length-to-width ratio of 1, e.g., the cross section may be a circle, a square, etc. Optionally, a cavity 152 may have a length-to-width ratio of 1.5 or more, 2 or more, 3 or more, or even 5 or more. Still further, according to other aspects, the cross section of the cavity 152 may extend more than 25 percent across the minimum back-surface dimension of the club head 102 at the location of the cavity. The regions of the club head 102 that extend on either side of the cavity 152 may be of equal thickness. Alternatively, these "legs" may be of unequal thickness. It may be desirable for the cross section of the cavity 152 to extend more than 50 percent or even more than 75 percent across the minimum back-surface dimension of the club head 102 at the location of the cavity 152.

[0057] Referring back to FIG. 2, the cavity 152a has a depth d. The depth d extends from the back surface 123 toward the front surface 121. Generally, the depth d may be determined as the maximum dimension from the opening of the cavity 152 on the back surface 123 to the bottom surface of the cavity. The depth d need not lie at any particular orientation to the back surface 123 or to the front surface 121. According to some aspects, the depth d of the cavity 152 may range from 2 mm to 15 mm. A depth d greater than 5 mm, or greater than 10 mm, or even greater than 12 mm may be desirable. As the cavity 152 is not a through hole, depth d is less than the front-to-back thickness of the club head 102 at the location of the cavity 152. Thus, the cavity 152 has a depth-to-club-head-thickness ratio of less than 1. According to certain aspects of the present disclosure, the cavity 152 has a depth-to-club-head-thickness ratio ranging from approximately 0.05 to approximately 0.9. Optionally, the cavity 152 may have a depth-to-club-head-thickness ratio greater than 0.2, greater than 0.5, greater than 0.75, or even greater than 0.85.

[0058] According to other aspects of the present disclosure, a cavity 152 may have a width-to-depth ratio ranging from approximately 0.1 (i.e., a relatively narrow, deep cavity) to approximately 20 (i.e. a relatively wide, shallow cavity). More preferably, the width-to-depth ratio may range from approximately 0.3 to approximately 10, or from approximately 0.5 to approximately 5, or even from approximately 0.8 to approximately 3. The bean-like shaped cavity 152c shown in FIG. 4C is an example of a relatively wide, shallow cavity. The irregular polygonal-shaped cavity 152d shown in FIG. 4D is an example of a relatively narrow, deep cavity.

[0059] According to another aspect, the cross section of the cavity 152 need not be constant as the depth of the cavity 152 increases. For example, as best shown in FIG. 4B, the cross-section area of cavity 152b decreases as the depth of the cavity 152b increases. In other words, the elliptical opening at the back surface 123 is larger than the elliptical bottom surface of the cavity 152b. According to other aspects, the shape of the cross section of the cavity 152 may change as the depth of the cavity 152 increases. For example, as shown in FIG. 4E, the cross section of the cavity 152e changes from square at the back surface 123 to circular at the bottom of the cavity 152e. FIG. 4E also illustrates that any change to the cross section of the cavities 152 need not be accomplished by a smooth transition, but may be accomplished in a step-wise fashion.

[0060] According to additional aspects of the disclosure, when viewed from the back surface 123, the cavity 152 may be aligned with the longitudinal axis L. As shown in FIGS. 3 and 4A-4E, a trace or projection of the longitudinal axis L, parallel to the longitudinal axis L, may lie within the cross section of the cavity 152. In other words, the trace of the longitudinal axis L may be seen within the cross section of the cavity 152 when the cavity is viewed from the back surface 123 along a line substantially perpendicular to the cross section of the cavity 152. Although, the trace of the longitudinal axis L may lie within the cross section of the cavity 152, this does not necessarily mean that the cavity 152 is deep enough to actually have the longitudinal axis L extend through the cavity.

[0061] Thus, according to other aspects of this disclosure, the longitudinal axis L may actually extend through the cavity 152. For example, as shown in FIG. 2, longitudinal axis L extends down through the center of neck region 130 and into the void formed by the cavity 152. This occurs because, when viewed from the back surface 123, the cavity 123 is aligned

with the longitudinal axis L, and also because the depth d of the cavity 152 extends beyond the location of the longitudinal axis L.

[0062] In general, when the angle of the longitudinal axis L of the club shaft 106 is adjusted relative to the main body 120, the material at the bend region 125 undergoes permanent deformation. The cavity 152 may provide a strain relief feature, in that the perimeter edges of the cavity may be deformed toward or away from one another when the club shaft angle is adjusted. With a cavity 152 having dimensions in both a transverse and a longitudinal direction, strain relief in both the transverse and the longitudinal directions may be provided. The cavity 152 may be formed by any conventional method, including for example by casting, forging, molding, machining, etching, etc.

[0063] Cavities 152 may be symmetrically oriented and positioned with respect to the longitudinal axis L. Referring back to FIG. 4B, cavity 152b is shown symmetrically oriented and positioned with respect to the longitudinal axis L. Even further, cavities 152 may be symmetrically oriented with respect to a perpendicular to the longitudinal axis L. Referring back to FIG. 4A, cavity 152a is shown symmetrically oriented with respect to a perpendicular to the longitudinal axis L. Similarly, in FIG. 4B, cavity 152a is also shown symmetrically oriented with respect to a perpendicular to the longitudinal axis L.

[0064] According to further aspects of the present disclosure, the cavity 152 may be located at least partially in the neck region 130, at least partially in the heel region 122, and/or at least partially in the transition region 132. Referring to FIG. 4A, cavity 152a is shown located mostly in the transition region 132 and at least partially in the neck region 130 and the heel region 122. Referring to FIG. 4B (and FIG. 4E), cavity 152b (and cavity 152e) is shown located in the neck region 130. Referring to FIG. 4C, cavity 152c is shown located at least partially in the neck region 130, in the transition region 132 and in the heel region 122.

[0065] Referring to FIG. 4D, cavity 152d is shown located at least partially in the transition region 132 and in the heel region 122.

[0066] Optionally, the cavity 152 may be located within a predetermined distance from the longitudinal axis L. This may be desirable as the golf club head 102 may be expected to deform along/or close to the longitudinal axis L due to the angle adjustment. Thus, according to certain aspects, the cavity 152 may be located at least partially within a radial zone of approximately 10 mm surrounding the longitudinal axis L. By way of non-limiting examples, the cavity 152 may be located at least partially within a radial zone of approximately 8 mm, or 6 mm, or even 4 mm, surrounding the longitudinal axis L.

[0067] According to even other aspects of the present disclosure, more than one cavity 152 may be provided by the angle adjustment void structure 150. By way of non-limiting examples, FIGS. 5A through 5B illustrate angle adjustment void structures 150 having a plurality of cavities 152. In FIG. 5A, cavities 152f and 152g are located within the longitudinal axis region 134. Further, even though the individual cavities 152f and 152g are not aligned with the longitudinal axis L, the angle adjustment void 150, which encompasses the pair of cavities 152f and 152g, is aligned with the longitudinal axis L.

[0068] The angle adjustment void structure 150 may be symmetrically oriented and positioned with respect to the longitudinal axis L. Referring to FIG. 5A, the angle adjust-

ment void structure **150** is shown symmetrically oriented and positioned with respect to the longitudinal axis L. In other words, although each individual cavity **152f** and **152g** is not symmetrically oriented with respect to the longitudinal axis L, the pair of cavities **152f** and **152g**, when taken together as the angle adjustment void structure **150**, is symmetric relative to the longitudinal axis L.

[0069] According to other aspects, the angle adjustment void structure **150** may be symmetrically oriented with respect to a perpendicular to the longitudinal axis L. Thus, referring back to FIG. 5A, the pair of cavities **152f** and **152g** of the angle adjustment void structure **150** is shown symmetrically oriented and positioned with respect a perpendicular to the longitudinal axis L.

[0070] As shown in FIG. 5B, each of the individual cavities **152h** and **152i** of the angle adjustment void structure **150** may be symmetrically oriented and positioned with respect to the longitudinal axis L. Even further, as best shown in FIG. 5B, it can be seen that the plurality of cavities **152** of the angle adjustment void structure **150** need not have the same cross-sectional shape or dimensions. By way of non-limiting example, the first cavity may have a shape, length, width and/or depth that is different than the shape, length, width and/or depth of the second cavity. Cavity **152h** has smaller length and width dimensions as compared to cavity **152i**. Further, the depth of cavity **152h** is less than the depth of cavity **152i**.

[0071] Club head **102** may be formed as a unitary piece (i.e., a single piece) or assembled from multiple pieces. The various parts of the club heads **102** may be made from conventional materials, in conventional constructions, in conventional manners, as are known and used in the art, optionally modified (if necessary, e.g., in size, shape, etc.) to accommodate the angle adjustment features described herein. For example, one or more of the various parts comprising the club head **102** may be made from a metal material, including lightweight metals conventionally used in golf club head constructions, such as aluminum, titanium, magnesium, nickel, alloys of these materials, steel, stainless steel, and the like, optionally anodized finished materials. Alternatively, if desired, one or more of the various parts of the club head **102** may be made from rigid polymeric materials, such as polymeric materials conventionally known and used in the golf club industry. The various parts of the club head **102** may be made from the same or different materials without departing from this disclosure. The parts may be made in conventional manners as are known and used in the metal working and/or polymer production arts. Further, any desired materials also may be used for the shaft **106**, including conventional materials that are known and used in the art, such as steel, graphite, polymers, composite materials, combinations of these materials, etc. Even further, the club head **102** may be attached to the club shaft **106** in any known manner using conventional fittings and materials. For example, the club head **102** may be permanently attached to the club shaft **106**, via bonding, brazing, welding, cements, adhesives, etc., or the club head **102** may be releasably attached to the club shaft, via threads, mechanical fasteners, etc. Optionally, a grip member (not shown) may be provided at the proximal end of the shaft **106**.

[0072] Many variations in the overall structure of the shaft, club head, and club head/shaft connection assembly are possible without departing from this disclosure. For example, the cavity may be filled, partially filled, or blocked off with a material that allows the cavity to deform under bending loads,

but that keeps dirt, debris or other objects from collecting in the cavity. For example, a plastic cap may be snapped or plugged into the opening of a cavity. As another example, the angle adjustment void structure may include one or more voids. A void is an empty space surrounded or partially surrounded by material. While an iron-type golf club head is illustrated in these figures, aspects of this disclosure may be applied to any type of club head, including, for example: fairway wood club heads; driver/wood-type golf club heads; hybrid golf club heads; putter heads; and the like.

#### Conclusion

[0073] While the disclosure has been described in detail in terms of specific examples including presently preferred modes of carrying out the disclosure, those skilled in the art will appreciate that there are numerous variations and permutations of the above described features and systems. Thus, the spirit and scope of the disclosure should be construed broadly as set forth in the appended claims.

We claim:

1. A golf club comprising:
  - a golf club shaft having a proximal end, a distal end, and a longitudinal axis extending therebetween; and
  - a golf club head attached to the distal end of the golf club shaft, the head including a front surface having a ball-striking surface and a back surface on the side opposite the front surface, the head further including:
    - an angle adjustment void structure located below the distal end of the golf club shaft, the angle adjustment void structure including a cavity formed in the back surface, a depth dimension of the cavity extending from the back surface toward the front surface, wherein the cavity, when viewed from the back surface, is aligned with the longitudinal axis.
2. The golf club according to claim 1, wherein the cavity is intersected by the longitudinal axis.
3. The golf club according to claim 1, wherein the depth of the cavity extends more than 50 percent through the thickness of the head at the location of the cavity.
4. The golf club according to claim 1, wherein the depth of the cavity extends more than 75 percent through the thickness of the head at the location of the cavity.
5. The golf club according to claim 1, wherein the depth of the cavity extends more than 85 percent through the thickness of the head at the location of the cavity.
6. The golf club according to claim 1, wherein the cavity is symmetric with respect to the longitudinal axis.
7. The golf club according to claim 1, wherein the cavity is symmetric with respect to an axis perpendicular to the longitudinal axis.
8. The golf club according to claim 1, wherein the head includes a neck region and wherein the cavity is located at least partially in the neck region.
9. The golf club according to claim 1, wherein the head includes a heel region and wherein the cavity is located at least partially in the heel region.
10. The golf club according to claim 1, wherein the cross section of the cavity extends more than 25 percent across the minimum back-surface dimension of the head at the location of the cavity.
11. The golf club according to claim 1, wherein the cross section of the cavity extends more than 50 percent across the minimum back-surface dimension of the head at the location of the cavity.

**12.** The golf club according to claim **1**, wherein the cross section of the cavity extends more than 75 percent across the minimum back-surface dimension of the head at the location of the cavity.

**13.** The golf club according to claim **1**, wherein the cavity has a cross section that is constant along the depth dimension.

**14.** The golf club according to claim **1**, wherein the angle adjustment void structure includes a second cavity formed in the back surface, the depth dimension of the second cavity extending from the back surface toward the front surface.

**15.** A golf club comprising:

a golf club shaft having an outer diameter, a proximal end, a distal end, and a longitudinal axis defined therebetween; and

a golf club head attached to the distal end of the golf club shaft, the head including a front surface having a ball-striking surface, a back surface on the side opposite the front surface, and a longitudinal axis region defined by projecting the outer diameter of the golf club shaft along an extension of the longitudinal axis, the head further including:

an angle adjustment void structure located below the distal end of the golf club shaft, the angle adjustment void structure including a cavity formed in the back surface, the cavity located at least partially in the longitudinal axis region.

**16.** The golf club according to claim **15**, further including a second cavity formed in the back surface and located at least partially in the longitudinal axis region.

**17.** The golf club according to claim **15**, wherein the cavity, when viewed from the back surface, is aligned with the longitudinal axis.

**18.** The golf club according to claim **15**, wherein the depth of the cavity extends more than 50 percent through the thickness of the head at the location of the cavity.

**19.** The golf club according to claim **15**, wherein the head includes a neck region and the first cavity is located at least partially in a neck region.

**20.** The golf club according to claim **15**, wherein the angle adjustment void structure is symmetric with respect to the longitudinal axis.

**21.** A golf club head comprising:

a main body extending from a heel region to a toe region; a neck region extending from the heel region to a connection region, the connection region configured for attachment to a distal end of a golf club shaft and defining a longitudinal axis; and

an angle adjustment void structure located below the connection region, the angle adjustment void structure including a cavity formed in a back surface of the golf club head, a depth dimension of the cavity extending from the back surface toward a front surface of the golf club head, wherein the cavity is at least partially located within a 10 mm radius of the longitudinal axis.

**22.** The golf club head according to claim **21**, wherein the cavity, when viewed from the back surface, is aligned with the longitudinal axis.

**23.** A golf club comprising:

a golf club shaft having a proximal end, a distal end, and a longitudinal axis extending therebetween; and

a golf club head attached to the distal end of the golf club shaft, the head including a front surface having a ball-striking surface and a back surface on the side opposite the front surface, the head further including:

a means for relieving strains located below the distal end of the golf club shaft, the means for relieving strains including a void formed in the back surface, a depth dimension of the void extending from the back surface toward the front surface, wherein the void, when viewed from the back surface, is aligned with the longitudinal axis.

**24.** The golf club according to claim **23**, wherein the depth of the void extends more than 50 percent through the thickness of the head at the location of the cavity.

**25.** The golf club according to claim **23**, wherein the cross section of the void extends more than 25 percent across the minimum back-surface dimension of the head at the location of the cavity.

**26.** The golf club according to claim **23**, wherein the means for relieving strain includes a second void formed in the back surface, the depth dimension of the second void extending from the back surface toward the front surface.

\* \* \* \* \*