



(12) **EUROPEAN PATENT APPLICATION**

(43) Date of publication:
27.03.2002 Bulletin 2002/13

(51) Int Cl.7: **H04R 25/00, H04R 3/02**

(21) Application number: **00610124.0**

(22) Date of filing: **01.12.2000**

(84) Designated Contracting States:
**AT BE CH CY DE DK ES FI FR GB GR IE IT LI LU
MC NL PT SE TR**
Designated Extension States:
AL LT LV MK RO SI

(72) Inventor: **Kaulberg, Thomas
Ganlose. DK-3660 Stenlose (DK)**

(74) Representative: **Raffnsøe, Knud Rosenstand et al
Internationalt Patent-Bureau,
23 Høje Taastrup Boulevard
2630 Taastrup (DK)**

(30) Priority: **25.09.2000 EP 00610097**

(71) Applicant: **TOPHOLM & WESTERMANN APS
DK-3500 Vaerloese (DK)**

(54) **A hearing aid with an adaptive filter for suppression of acoustic feedback**

(57) The present invention relates to a hearing aid with an adaptive filter for suppression of acoustic feedback in the hearing aid. The hearing aid further comprises a controller that is adapted to compensate for acoustic feedback by determination of a first parameter of an

acoustic feedback loop of the hearing aid and adjustment of a second parameter of the hearing aid in response to the first parameter whereby generation of undesired sounds is substantially avoided. Hereby a gain safety margin requirement is significantly reduced.

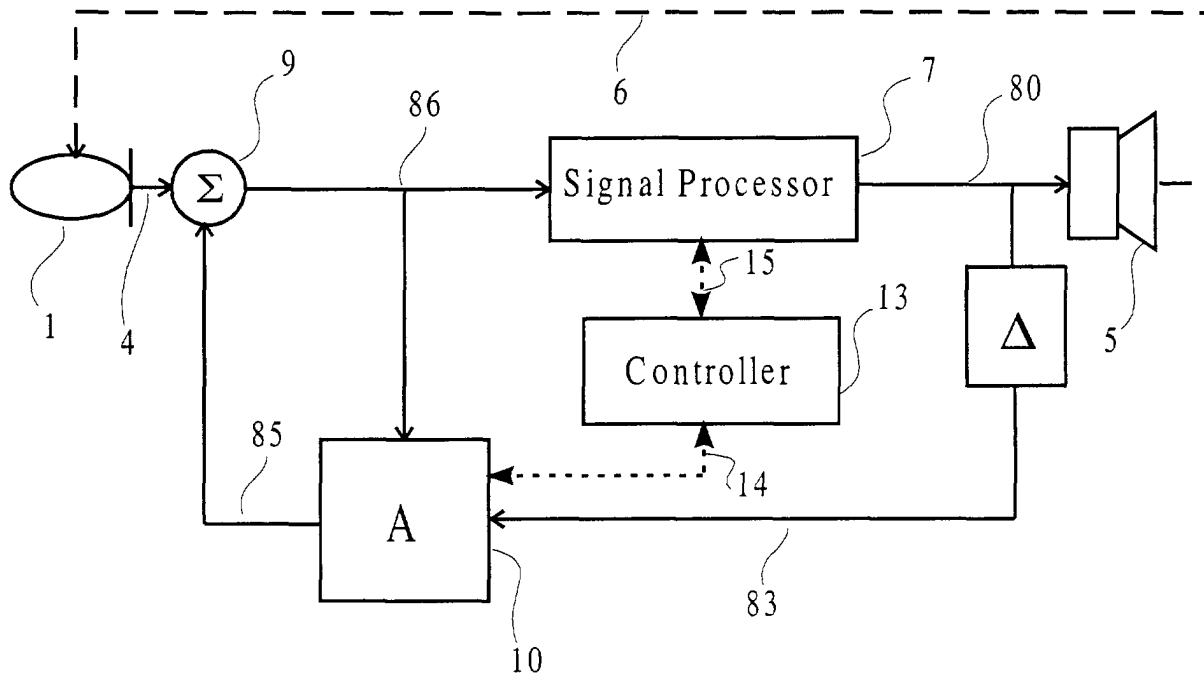

Figure 1

Description

[0001] The present invention relates to a hearing aid with an adaptive filter for suppression of acoustic feedback in the hearing aid.

5 [0002] It is well known in the art of hearing aids that acoustic feedback may lead to generation of undesired acoustic signals which can be heard by the user of a hearing aid.

[0003] Acoustic feedback occurs when the input transducer of a hearing aid receives and detects the acoustic output signal generated by the output transducer. Amplification of the detected signal may lead to generation of a stronger acoustic output signal and eventually the hearing aid may oscillate.

10 [0004] It is well known to include an adaptive filter in the hearing aid to compensate for acoustic feedback. The adaptive filter estimates the transfer function from output to input of the hearing aid including the acoustic propagation path from the output transducer to the input transducer. The input of the adaptive filter is connected to the output of the hearing aid and the output signal of the adaptive filter is subtracted from the input transducer signal to compensate for the acoustic feedback. A hearing aid of this type is disclosed in US 5,402,496.

15 [0005] In such a system, the adaptive filter operates to remove correlation from the input signal, however, signals representing speech and music are signals with significant auto-correlation. Thus, the adaptive filter cannot be allowed to adapt too quickly since removal of correlation from signals representing speech and music will distort the signals, and such distortion is of course undesired. Therefore, the convergence rate of adaptive filters in known hearing aids is a compromise between a desired high convergence rate that is able to cope with sudden changes in the acoustic environment and a desired low convergence rate that ensures that signals representing speech and music remain undistorted.

20 [0006] The lack of speed of adaptation may still lead to generation of undesired acoustic signals due to acoustic feedback. Generation of undesired acoustic signals is most likely to occur at frequencies with a high feedback loop gain. The loop gain is the attenuation in the acoustic feedback path multiplied by the gain of the hearing aid from input to output.

25 [0007] Acoustic feedback is an important problem in known CIC hearing aids (CIC = complete in the canal) with a vent opening since the vent opening and the short distance between the output and the input transducers of the hearing aid lead to a low attenuation of the acoustic feedback path from the output transducer to the input transducer, and the short delay time maintains correlation in the signal.

30 [0008] Various measures are well known in the art to cope with acoustic feedback. For example, it is well known to keep the loop gain below a certain limit in order to prevent generation of feedback resonance. It is also known to adjust the phase of the feedback signal, to perform a frequency transpose, and to compensate for the feedback signal.

35 [0009] Typically, the acoustic environment of the hearing aid changes over time, and often changes rapidly over time, in such a way that propagation of sound from the output transducer of the hearing aid to its input transducer changes drastically. For example, such changes may be caused by changes in position of the user in a room, e.g. from a free field position in the middle of the room to a position close to a wall that reflects sound. Changes may also be generated if the user yawns or if the user puts the receiver of a telephone to the ear. Such changes, some of which may be almost instantaneous, are known to involve changes in attenuation of the feedback path of more than 20 dB.

40 [0010] It is known to keep the loop gain below a safe limit by limiting the gain adjustment in the hearing aid to a maximum allowable gain based on experience. However, a large safety margin is needed to cope with the above-mentioned variations in the acoustic environment and with variations in physical fitting of the hearing aid to the wearer. It is also known to determine the maximum allowable gain during fitting of the hearing aid to a specific user. However, a large safety margin is still needed. The safety margin prevents the capabilities of the hearing aid to be fully exploited, such as in situations where the gain could be adjusted to a value that is higher than the maximum allowable gain without generation of undesired sounds.

45 [0011] In order to be able to compensate for a severe hearing deficiency, it is desirable to be able to set a high gain in the hearing aid. However, the risk of generating oscillation, also denoted feedback resonance, restricts the maximum gain that may be employed, even in situations with a high attenuation in the acoustic feedback path.

50 [0012] In DE-A-19802568 and US 5,016,280, a hearing aid is disclosed including a measuring system for determining the characteristics of the acoustic feedback path. A test signal is transmitted through the system in order to determine the characteristics of the feedback path.

[0013] In DE-A-19802568 the coefficients in a digital filter is determined based on the impulse response of the feedback path, and in US 5,016,280 the filter coefficients of an adaptive compensation filter is calculated using a leaky LMS algorithm operating on white-noise signals transmitted through the feedback path.

55 [0014] The respective measuring systems are rather complicated and the duration of the determination is relatively long, and the normal function of the hearing aid is interrupted during the determination. Thus, the determination is performed at certain occasions only, e.g. when the user switches the hearing aid on. Thus, still, a relatively high safety margin for the gain is needed to cope with changes in the acoustic environment between determinations.

5 [0015] In US 5,619,580 a hearing aid with an adaptive filter and a continuously operating measuring system is disclosed. A pseudo random noise signal is injected into the output signal. A monitoring system controls the gain of the hearing aid so that the loop-gain is kept below a constant value which may be frequency dependent. The filter coefficients of the adaptive filter are monitored and their update rate is adjusted according to a statistical analysis which complicates the system. It is another disadvantage of the system that a noise generator is needed and that the generated noise signal is always present. Moreover, the system increases the adaptation rate and thus deteriorates the signal quality when a change in acoustic environment is detected also in situations where the hearing aid is not operating close to resonance.

10 [0016] Thus, there is a need for an improved hearing aid that overcomes the above-mentioned disadvantages and substantially eliminates the requirement of a gain safety margin so that the operating gain in certain acoustic environments can be higher than for known hearing aids.

15 [0017] According to a first aspect of the invention, these and other objects are fulfilled by a method of suppressing acoustic feedback in a hearing aid, comprising the steps of: transforming an acoustic input signal into a first electrical signal, dividing the first electrical signal into a set of bandpass filtered first electrical signals, processing each of the bandpass filtered first electrical signals individually, adding the processed electrical signals into a second electrical signal, transforming the second electrical signal into an acoustic output signal, dividing the second electrical signal into a set of bandpass filtered second electrical signals, estimating acoustic feedback by generation of third electrical signals by adaptive filtering of the bandpass filtered second electrical signals and adapting the filtered signals to respective signals on the input side of the processor with respective first convergence rates, and compensating for acoustic feedback by determining a first parameter of an acoustic feedback loop of the hearing aid, and adjusting a second parameter of the hearing aid in response to the first parameter whereby generation of undesired sounds, such as howling, signal distortion, etc, is substantially avoided.

20 [0018] According to a second aspect of the invention, these and other objects are fulfilled by a hearing aid with an adaptive filter for compensation of acoustic feedback. The adaptive filter operates to estimate the transfer function from output to input of the hearing aid including the acoustic propagation path from the output transducer to the input transducer. The input of the adaptive filter is connected to the electric output of the hearing aid and the output signal of the adaptive filter may be subtracted from the input transducer signal to compensate for the acoustic feedback. The hearing aid further comprises an input transducer for transforming an acoustic input signal into a first electrical signal, a first filter bank with bandpass filters for dividing the first electrical signal into a set of bandpass filtered first electrical signals, a processor for generation of a second electrical signal by individual processing of each of the bandpass filtered first electrical signals and adding the processed electrical signals into the second electrical signal, and an output transducer for transforming the second electrical signal into an acoustic output signal. The hearing aid may also comprise a second filter bank with bandpass filters for dividing the second electrical signal into a set of bandpass filtered second electrical signals, a first set of adaptive filters with first filter coefficients for estimation of acoustic feedback by generation of third electrical signals by filtering of the bandpass filtered second electrical signals and adapting the respective third signals to respective signals on the input side of the processor with respective first convergence rates.

30 [0019] It is a characteristic feature of the hearing aid that it further comprises a controller that is adapted to compensate for acoustic feedback by determination of a first parameter of an acoustic feedback loop of the hearing aid and adjustment of a second parameter of the hearing aid in response to the first parameter whereby generation of undesired sounds is substantially avoided.

35 [0020] It is an important advantage of the present invention that the requirement of a gain safety margin is significantly reduced since the controller automatically adjusts a parameter of the electronic feedback loop whenever the hearing aid operates with a high risk of generating undesired sounds so that such generation is substantially avoided.

[0021] In the following, the frequency ranges of the bandpass filters are also denoted channels.

40 [0022] In a simple embodiment of the invention, the hearing aid is a single channel hearing aid, i.e. the hearing aid processes incoming signals in one frequency band only. Thus, the first filter bank consists of a single bandpass filter, and the single bandpass filter may be constituted by the bandpass filter that is inherent in the electronic circuit, i.e. no special circuitry provides the bandpass filter. Correspondingly, the adding in the processor of processed electrical signals is reduced to the task of providing the single processed electrical signal at the output of the processor. Further, the second filter bank consists of a single bandpass filter, and the first set of adaptive filters consists of a single adaptive filter.

45 [0023] Typically, hearing defects vary as a function of frequency in a way that is different for each individual user. Thus, the processor is preferably divided into a plurality of channels so that individual frequency bands may be processed differently, e.g. amplified with different gains. Correspondingly, the hearing aid may comprise a first set of adaptive filters with a plurality of adaptive filters for individual filtering of signals in respective frequency bands whereby a capability of individually controlling acoustic feedback in each channel of the hearing aid is provided. Preferably, the frequency bands of the first set of adaptive filters are substantially identical to the frequency bands of the first filter bank so that the bandpass filters do not deteriorate the operation of the adaptive filters.

[0024] In one embodiment of the invention, the first set of adaptive filters subtracts the electrical output of the hearing aid from the input to the processor and the difference signal is used for modification of the filter coefficients as explained below. The difference signal is not used for modification of the input signal to the processor whereby distortion of the signal is avoided. Thus, in this embodiment of the invention the first adaptive filter is used for estimation of the acoustic feedback signal without distortion of the processed signal. Further, in this embodiment, at least one of the adaptive filters of the first set of adaptive filters may operate on a respective decimated bandpass filtered second electrical signal whereby signal processing power requirement is minimised without requiring additional further filters since the adaptive filter output signal does not affect the processed signal directly.

[0025] In another embodiment of the invention, the first set of adaptive filters subtracts the electrical output of the hearing aid from the electrical signal from the input transducer and the difference signal is used for modification of the filter coefficients and is fed to the input of the processor whereby the acoustic feedback signal is substantially removed from the signal before processing by the processor. In this embodiment, decimation of signals may be employed in the processor and in the first set of adaptive filters if a third filter bank that is substantially identical to the first filter bank is added in the processor before summation of the individual processed signals from each processor channel to the output signal from the processor.

[0026] Generation of undesired sounds may be avoided by monitoring of the loop gain of the acoustic feedback loop, i.e. the gain of the acoustic feedback path from the output transducer to the input transducer including the transfer functions of the transducers plus the gain of the electronic circuitry included in the signal path from input to output of the hearing aid. When the loop gain approaches one, certain actions may be taken to prevent generation of unwanted sounds. Since the first set of adaptive filters generates a signal that corresponds to the signal generated by acoustic feedback, monitoring of attenuation in the first set of adaptive filters and of gains in corresponding channels of the processor provides an indication of the loop gain of the acoustic feedback loop. Thus, the controller may be adapted to monitor attenuation in the first set of adaptive filters, e.g. by determination of the individual ratios between the magnitude of the signal at the inputs of the individual filters and the signals at the corresponding outputs of the individual filters. Further, the controller may be adapted to monitor the gains of the individual channels of the processor, e.g. by a similar determination of input and output signal levels of individual processor channels, or by reading values from registers in the processor containing current gain values of individual processor channels. Typically, the processor channel gains are different for different channels and they are input level dependent.

[0027] Based on the monitoring of a first parameter of the acoustic feedback loop, such as the loop gain, the gain of a processor channel, the attenuation of an adaptive filter of the first set of adaptive filters, etc, a second parameter of the hearing aid may be adjusted to prevent generation of undesired sounds. For example, the gain of at least one processor channel may be modified, e.g. lowered, to keep the acoustic feedback loop gain below one.

[0028] The second parameter may be a maximum gain limit G_{\max} that the gain of the processor is not allowed to exceed within a specific channel. The adaptation rate of the first set of adaptive filters may be kept constant while the maximum gain limit G_{\max} of a specific channel of the processor is lowered whenever the hearing aid approaches a state in that channel with a high risk of generating undesired sounds, e.g. caused by a sudden change in the acoustic environment. For example, the maximum gain limit G_{\max} of a specific channel is lowered while the first adaptive filter adapts to a changed acoustic environment, and is restored to the original value when the adaptive filter has adapted to the new situation. Hereby, no distortion of the desired signal is generated.

[0029] It is an important advantage of this embodiment of the invention that the operating gain of the hearing aid may be very high without a risk of generating undesired sounds since the gain is automatically lowered if the feedback loop approaches resonance. Thus, a gain safety margin is substantially not required.

[0030] In embodiments wherein the bandpass filters of the second filter bank are substantially identical to respective bandpass filters of the first filter bank, each channel may be individually controlled based on a determination in that channel whereby reduction of gain by influence from frequencies outside the channel in question may be avoided.

[0031] Further, in an embodiment of the invention wherein the difference signal from the first adaptive filter is fed to the input of the processor, the second parameter may be a first convergence or adaptation rate of the first set of adaptive filters. For example, the adaptation rate of the filter may be made dependent on the operating processor gain in such a way that whenever the hearing aid approaches a state with a high risk of generating undesired sounds, e.g. caused by a sudden change in the acoustic environment, the adaptation rate of the first adaptive filter is increased to rapidly compensate for the change.

[0032] The convergence rate of the first set of adaptive filters may be adjusted by modifying the algorithm for updating the filter coefficients of the adaptive filter. As further described below, the algorithm may comprise one or more scaling factors that may be adjusted in response to the determination of the first parameter. For example, the one or more scaling factors may be adjusted as a predetermined function of the operating gains of the processor.

[0033] It is an important advantage of this embodiment that the operating gain of the hearing aid may be very high without a risk of generating undesired sounds since the closer the acoustic feedback loop gain approaches resonance the faster the adaptive filter will adapt to the situation. The fast adaptation of the adaptive filter may cause the desired

signal to be distorted as previously described. However, as soon as the adaptive filter has adapted, the convergence rate is lowered and the desired signal is no longer distorted. Further, the distortion may take place in a frequency band that does not affect the intelligibility of the received sound signal.

[0034] A gain interval from G_0 to G_a may be provided in the hearing aid. G_0 is a predetermined lower gain limit below which feedback resonance and generation of undesired sounds can not occur. G_0 may be determined during the fitting procedure. G_a is an adjustable upper gain limit that is adjusted according to desired sound quality. Preferably, G_a is adjusted during the fitting procedure.

[0035] The convergence rate may vary as a predetermined function, such as a linear or a non-linear function, of the gain of the processor, e.g. in the range from G_0 to G_a . For example, one or more scaling factors of the updating algorithm of the adaptive filter may vary as a predetermined function, such as a linear or a non-linear function, of the gain of the processor, e.g. in the range from G_0 to G_a .

[0036] During fitting of the hearing aid to the individual user, the transmission characteristics of the feedback path is measured. Based on these characteristics, the values of G_0 and G_a with appropriate safety margins are determined and stored in the hearing aid. For determination of G_0 there are several factors to take into consideration. The feedback path characteristics are, as already mentioned, not constant. Thus, sudden changes may lead to feedback resonance if the feedback compensation is too slow. Further, prediction of the magnitude and duration of changes of the attenuation of the feedback path may be difficult. On the other hand, fast adaptation may lead to unacceptable distortion of the desired signal, the level of unacceptable distortion again being a subjective quantity.

[0037] However, in situations where the characteristics of the acoustic feedback path have been stable for a certain period it is possible to estimate the characteristics of the feedback path accurately since in such a situation the relation between the signals at the inputs of the first set of adaptive filters and the signals at the outputs of the first set of adaptive filters is a precise measure for such characteristics, e.g. the attenuation, of the acoustic feedback path. Knowing the gain characteristics of the digital processor and of the acoustic feedback signal, an estimate for the acoustic feedback loop may be provided. From this knowledge, a dynamically changing value of G_0 may be incorporated in the hearing aid. In one embodiment the interval from G_0 to G_a may have a fixed size, independent of the changes in G_0 , i.e. the entire interval is shifted in accordance with changes of G_0 .

[0038] According to a preferred embodiment of the invention, the hearing aid further comprises a second set of adaptive filters operating in parallel with, i.e. on the same signals as, the first set of adaptive filters but with second convergence rates that are lower than the first convergence rates of the first set of adaptive filters. The outputs of the second set of adaptive filters are fed to the corresponding inputs of the processor whereby the acoustic feedback signal is substantially removed from the signal before processing by the processor. The outputs of the first set of adaptive filters are not used for modification of the processor input signals.

[0039] In this embodiment, the controller is adapted to estimate the amount of acoustic feedback by determination of a parameter of the first set of adaptive filters. The high first convergence rate allows the first adaptive filter to track the acoustic feedback more closely over time than the second adaptive filter. Further, since the output signal of the first adaptive filter is not subtracted from the input transducer signal, the desired signal is not distorted by the first adaptive filter.

[0040] Thus, according to a preferred embodiment of the invention, a hearing aid is provided further comprising a set of second adaptive filters with second filter coefficients for suppression of feedback in the hearing aid by filtering the bandpass filtered second electrical signals into respective fourth electrical signals, a combining node for generation of fifth electrical signals by subtraction of the fourth electrical signals from the respective bandpass filtered first electrical signals and for feeding the fifth electrical signals to the processor, and wherein the second filter coefficients are updated with a second convergence rate that is lower than the first convergence rate.

[0041] The amount of acoustic feedback may be estimated by determination of the ratio between the magnitude of the signals at the inputs of the first set of adaptive filters and the signals at the respective outputs of the first set of adaptive filters. This approach provides a quick response to changes in the acoustic feedback path and requires very little processor power.

[0042] The second parameter may be a second convergence or adaptation rate of the second set of adaptive filters. For example, the adaptation rate of the filtering may be made dependent on the operating gain of the processor or, the attenuation of the first set of adaptive filters or, a combination of the two, in such a way that whenever the hearing aid approaches a state with a high risk of generating undesired sounds, e.g. caused by a sudden change in the acoustic environment, the adaptation rate of the second adaptive filter is increased to rapidly compensate for the change.

[0043] As previously described for the first set of adaptive filters, the convergence rate of the second set of adaptive filters may be adjusted by modifying the algorithm for updating the filter coefficients of the adaptive filters. As further described below, the algorithm may comprise one or more scaling factors that may be adjusted in response to the determination of the first parameter. For example, the one or more scaling factors may be set as a predetermined function of the operating gains of the processor.

[0044] The second set of adaptive filters provides individual filtering of signals in respective frequency bands. Pref-

erably, the frequency bands of the second set of adaptive filters are substantially identical to the frequency bands of the first filter bank.

[0045] The frequency bands of the second set of adaptive filters may differ in number and range from the frequency bands of the first filter bank and the first set of adaptive filters. However, in a preferred embodiment of the present invention, the first filter bank comprises a plurality of bandpass filters while the second set of adaptive filters consists of a single adaptive filter providing modification of the processor input signal in a single frequency band whereby a hearing aid with a frequency dependent hearing aid compensation capability is provided with a simple single band acoustic feedback compensation loop.

[0046] Thus, according to a preferred embodiment of the present invention, a hearing aid is provided further comprising a second adaptive filter with second filter coefficients for suppression of feedback in the hearing aid by filtering the second electrical signal into a fourth electrical signal, a combining node for generation of a fifth electrical signal by subtraction of the fourth electrical signal from the first electrical signal and for feeding the fifth electrical signal to the respective bandpass filters of the first filter bank, and wherein the second filter coefficients are updated with a second convergence rate that is lower than the first convergence rate.

[0047] Thus, in a preferred embodiment of the invention, the processor and the first adaptive filter are divided into channels covering the same frequency bands while the second adaptive filter is not divided into a plurality of channels. Further, the controller may be adapted to control the individual maximum gain limits G_{max} of each processor channel in response to determination of the attenuation of the corresponding first adaptive filter channel. The controller may further be adapted to increase a second convergence rate of a filter of the second set of adaptive filters when the corresponding processor channel gain is limited by a G_{max} limit so that the duration of the gain limitation may be decreased. Still further, the controller may be adapted to adjust the gain limit and/or the convergence rate in accordance with the current mode of operation of the hearing aid. The term mode of operation will be explained below.

[0048] Preferably, at least one adaptive filter is a finite impulse response (FIR) filter, and even more preferred at least one adaptive filter is a warped filter, such as a warped FIR filter, a warped infinite impulse response (IIR) filter, etc.

[0049] In the present example of a warped FIR filter, the unit delays are substituted by first order allpass sections. However, the warping may as well be realised with second order and even higher order allpass sections. A first order allpass section has the z-transform:

$$\frac{z^{-1} - \gamma}{1 - z^{-1} \gamma}$$

where γ is a warping parameter. Thus, the fixed delays in a FIR filter are substituted by frequency dependent delays leading to large delays at low frequencies and smaller delays at high frequencies. It should also be noted that the allpass elements are internally recursive and therefore warped FIR filters have infinite impulse responses. Thus, the term warped FIR is somewhat contradictory but describes well the structural analogy to transversal FIR filters.

[0050] In embodiments of the present invention, the order of a warped FIR filter may be considerably lower than the order of a FIR filter with comparable specifications. Thus, for a given circuit complexity, a warped FIR filter is capable of providing better filter characteristics than a FIR filter. Further, the warping parameter γ may be used as a control parameter for controlling the transfer function, i.e. the positioning of resonances and cut-off frequencies in the frequency spectrum, whereby the spectrum of the error signal $e(n)$, i.e. the difference between the filter output signal and the desired signal, may be minimised within a desired frequency range.

[0051] In the FIR or warped FIR filter, the next sample $Y(t+T)$ is calculated according to the following equation:

$$Y(t+T) = \underline{c}(t) \underline{u}(t)$$

where

5
10

$$\underline{c}(t) = \begin{pmatrix} c_0 \\ c_1 \\ \vdots \\ c_i \\ \vdots \\ c_{N-1} \end{pmatrix} \text{ and } \underline{u}(t) = \begin{pmatrix} u_0 \\ u_1 \\ \vdots \\ u_i \\ \vdots \\ u_{N-1} \end{pmatrix} = \begin{pmatrix} u(t) \\ u(t - T) \\ \vdots \\ u(t - iT) \\ \vdots \\ u(t + T - NT) \end{pmatrix}$$

15 **[0052]** It is noted that \underline{u} is an N dimensional vector containing the latest N samples of the signal u and \underline{c} is a vector containing the N coefficients of the N'th order filter. T is the sampling period.

[0053] In the equation, u(t) is the actual value at the actual time t, and u(t-iT) is the signal value at i sampling periods prior to the actual time t. In discrete time systems, a shorthand notation is often used where the symbol u(i) indicates the signal value at the time t-iT, i.e. u(t-iT) in the equation above.

20 **[0054]** It is well known, e.g. cf. Adaptive Filtering by Paulo S. R. Diniz, Kluwer Academic Publishers, 1997, to use a least mean square algorithm for updating of the filter coefficients in an adaptive filter:

$$\underline{c}(t+T) = \underline{c}(t) + \mu \underline{u}(t)e(t)$$

25 **[0055]** Using the above-mentioned shorthand notation (n is the reference number of the actual sample), the equation is rewritten:

30
35

$$\begin{pmatrix} c_0(n+1) \\ c_1(n+1) \\ \vdots \\ c_i(n+1) \\ \vdots \\ c_{N-1}(n+1) \end{pmatrix} = \begin{pmatrix} c_0(n) \\ c_1(n) \\ \vdots \\ c_i(n) \\ \vdots \\ c_{N-1}(n) \end{pmatrix} + \mu \cdot e(n) \cdot \begin{pmatrix} u_0(n) \\ u_1(n) \\ \vdots \\ u_i(n) \\ \vdots \\ u_{N-1}(n) \end{pmatrix}$$

40 **[0056]** Or in an even shorter form:

$$c_i(n+1) = c_i(n) + \mu u_i(n)e(n)$$

45 wherein i references the individual vector elements.

[0057] It is preferred to use a leaky least mean square algorithm is used for updating the filter coefficients:

$$c_i(n+1) = \lambda(c_i(n)-c_i(0)) + c_i(0) + \mu u_i(n)e(n),$$

50

where u_i is a set of signal values derived from the output signal of digital processor in the n'th sampling period and the i-1 preceding sampling periods, c_i is a set of filter coefficients, e is the current value of the error signal and λ and μ are scaling factors. The value of μ is typically in the magnitude of 10^{-6} and the value of λ is typically approximately 0.99. λ is denoted leakage and when $\lambda < 1$, the filter coefficients will drift towards their respective initial values $c_i(0)$. μ is the convergence rate and determines the rate with which the adaptive filter adapts to a change. The adaptation rate increases with increasing values of μ .

55

[0058] It may further be advantageous to normalise the algorithm so that the adaptive filter, substantially, does not respond to momentary dynamic changes in the input signal. It should be noted that for the purpose of estimating the

acoustic feedback signal, the desired input signal is irrelevant and constitutes noise deteriorating the convergence performance of the adaptive filter. The normalised algorithm is referred to as a normalised Least Mean Square (nLMS) algorithm:

5

$$\underline{c}(n+1) = \lambda(\underline{c}(n) - \underline{c}(0)) + \underline{c}(0) + \mu \frac{u(n)}{\underline{u}(n) \cdot \underline{u}(n)} e(n).$$

[0059] However in the above equation the calculation of the power requires significant processing power and consequently, it is preferred to use a power estimate according to the equation:

10

$$P_u(t+T) = \alpha P_u(t) + (1-\alpha)u^2(t)$$

15 where α is a predetermined constant that determines the rate with which the P_u estimate changes. The algorithm is referred to as a power normalised Least Mean Square algorithm. The power estimate may also be based on the output signal from the input transducer so that the influence from sudden changes in the power of the input signal on the adaptation algorithm is minimised.

[0060] Further, a third update algorithm may be used for updating the adaptive filter coefficients denoted a leaky sign least mean square algorithm:

20

$$c_i(n+1) = \lambda(c_i(n)-c_i(0)) + c_i(0) + \mu_s u_i(n)$$

25 where μ_s is the sign of the $e(n)$ signal multiplied by μ .

[0061] Still further, a fourth update algorithm that may be used for the adaptive filter coefficients denoted a leaky sign-sign least mean square algorithm:

30

$$c_i(n+1) = \lambda(c_i(n)-c_i(0)) + c_i(0) + \mu_s \text{sgn}(u_i(n))$$

where $\text{sgn}(u_i(n))$ is the sign of $u_i(n)$.

[0062] The filter coefficients may be updated based on a difference signal that is processed, e.g. combined with another signal, averaged or otherwise filtered, etc. Filtering may be performed in a focussed manner as known in the art.

35 [0063] Further, it should be noted that in a multichannel hearing aid according to the invention, the adaptive filters of the channels need not have identical number of taps. For example, it may be desirable to include more taps in adaptive filters operating in low-frequency channels.

[0064] As already mentioned, the controller may adjust λ and μ in response to the determination of a first parameter of the acoustic feedback loop of the hearing aid.

40 [0065] Various sets of parameters of the hearing aid may be provided for various respective types of sound, e.g. speech, music, etc, that the user desires to hear and various respective types of acoustic environment, e.g. silence, noise, echo, crowd, open air, room, head set, etc, in which the user is situated. For example, various gain settings as a function of frequency may be provided, various gain settings as a function of input signal level may be provided, and various convergence rates as a function of operating processor gain may be provided, etc. Each set of parameters defines a specific mode of operation of the hearing aid and when the hearing aid operates with a specific set of parameters it is said to operate in the corresponding mode. Thus, in a specific mode of operation, specific parameter values of the hearing aid are set for appropriately processing of corresponding specific sounds in a specific acoustic environment. Likewise automatic adjustment of the parameters may be performed in accordance with the current mode of operation.

50 [0066] The type of sound may be selected by the user or, it may be automatically detected by the hearing aid, e.g. by a frequency analysis, analysis of signal to noise ratio at various frequencies, analysis of sound dynamics, speech recognition, recognition by neural networks, etc.

[0067] Likewise, the type of acoustic environment may be selected by the user or, it may be automatically detected by the hearing aid, e.g. by a frequency analysis, analysis of signal to noise ratio at various frequencies, analysis of sound dynamics, recognition by neural networks, etc.

55

[0068] For example, the user may desire to listen to music. The first convergence rate of the first adaptive filter may then be set to a value that is in conformance with the auto-correlation of music. Further, gain adjustments or adjustments of the first convergence rate may also be performed in conformance with the auto-correlation of music. For example,

when the first convergence rate, e.g. one or more scaling factors, is controlled as a function of processor gain, the function may be selected from a set of functions, each of which is adapted for use in a specific acoustic environment with certain sounds, such as music, speech, etc, that the user has decided to listen to.

[0069] Furthermore, adjustments may also be performed in accordance with the rate of change of measured parameters, e.g. of the acoustic feedback path, e.g. the feedback gain, etc, etc.

[0070] The invention will now be explained in greater detail with reference to the drawing in which

Fig. 1 is a block diagram of a hearing aid according to the present invention,

Fig. 2 is a block diagram of a multichannel hearing aid in which each channel corresponds to the hearing aid shown in Fig. 1,

Fig. 3 is a block diagram of a hearing aid incorporating a measuring system according to the invention,

Fig. 4 is a block diagram of a multichannel hearing aid in which each channel corresponds to the hearing aid shown in Fig. 3,

Fig. 5 is a block diagram of a multichannel hearing aid with a single band adaptive filter,

Fig. 6 is a block diagram illustrating an LMS type FIR filter implementing the update algorithms according to the invention,

Fig. 7 is a block diagram illustrating an LMS type warped FIR filter implementing the update algorithms according to the invention,

Fig. 8 is a plot of an impulse response of a FIR filter compared to an impulse response of a warped FIR filter,

Fig. 9 is a plot of the deviation from a desired transfer function of a FIR filter and a warped FIR filter,

Fig. 10 is a diagram representing possible variations in the filter coefficients in dependence of the gain in the digital processor, and

Fig. 11 is a diagram illustrating the improvement in maximum possible gain achieved with the present invention.

[0071] Fig. 1 is a schematic block diagram of an embodiment of the present invention. It will be obvious for the person skilled in the art that the circuits indicated in Fig. 1 may be realised using digital or analogue circuitry or any combination hereof. In the present embodiment, digital signal processing is employed and thus, the processor 7 and the adaptive filter 10 are digital signal processing circuits. In the present embodiment, all the digital circuitry of the hearing aid may be provided on a single digital signal processing chip or, the circuitry may be distributed on a plurality of integrated circuit chips in any appropriate way.

[0072] In the hearing aid an input transducer 1, such as a microphone, is provided for reception of sound signals and conversion of the sound signals into corresponding electrical signals representing the received sound signals. The hearing aid may comprise a plurality of input transducers 1, e.g. whereby certain direction sensitive characteristics may be provided. The input transducer 1 has a transfer function H_m . The input transducer 1 converts the sound signal to an analogue signal. The analogue signal is sampled and digitised by an A/D converter (not shown) into a digital signal 4 for digital signal processing in the hearing aid. The digital signal 4 is fed to a combining node 9 where it is combined with a feedback compensation signal 85 which will be explained later. The combining node 9 outputs an output signal 86 which is fed to a digital signal processor 7 for amplification of the output signal 86 according to a desired frequency characteristic and compressor function to provide an output signal 80 suitable for compensating the hearing deficiency of the user.

[0073] The output signal 80 is fed to an output transducer 5 and an optional delay Δ and the delayed signal 83 is fed to an adaptive filter 10. The output transducer 5 converts the output signal 80 to an acoustic output signal 6. A part of the acoustic signal propagates to the input transducer 1 along a feedback path having a transfer function H_{fb} . Preferably, the time delay of the delay line Δ is substantially equal to the transit time of the signal 6 from the output transducer 5 to the input transducer 1. Other time delays may be selected. However, shorter time delays or zero time delay complicates the filtering, e.g. when the filters are Finite Impulse Response filters longer filters will be necessary, i.e. filters with more taps. Thus, a further delay may be inserted in the circuit at the output of the processor 7 and feeding a delayed signal to the output transducer 5 and the optional delay Δ thereby decreasing the correlation between input

signal 4 and filtered signal 85.

[0074] In the adaptive filter 10, the delayed signal 83 is filtered in order to provide a filtered signal 85 that is an estimate of the acoustic feedback, i.e. the filtered signal 85 is an estimate of the part of the transducer generated signal 4 that is generated by reception of sound originating from the output transducer 5. The filtered signal 85 is subtracted from the digital input signal 4 in the combining node 9 whereby a feedback compensated signal 86 is provided and input to the digital processor 7. In order to compensate for changes in the acoustic feedback path, the filter coefficients of the adaptive filter 10 are continuously updated so that the filtered signal 85 stays substantially identical to the feedback signal 6.

[0075] The filter 10 is a finite impulse response (FIR) filter or a warped FIR filter with a leaky sign-sign least mean square algorithm as disclosed above.

[0076] The controller adjusts λ and μ in response to the actual gain in the processor 7. A plot of the scaling factors λ and μ as functions of the gain is shown in Fig. 10. It should be noted that these functions may depend on the mode of operation of the hearing aid. A set of selectable subsets of functions as those shown in Fig. 10 may be provided that may be selected by the controller 13 in accordance with the current mode of operation of the hearing aid. Further, the functions may be selected in accordance with the rate of change of a measured parameter, e.g. attenuation in the acoustic feedback path.

[0077] In the embodiment of Fig. 1 the controller 13 receives information from the digital processor 7 via a line 15. According to the information received via line 15 about the current operating gain in the digital processor 7, the controller adjusts the adaptation rate for the filter coefficients of the adaptive filter 10. It should be noted that in the present drawing, dashed lines and arrows indicate control lines that do not form part of the signal path of the processed signal.

[0078] A FIR filter embodiment of the filter 10 is shown in more detail in Fig. 6. For simplicity only the first four taps are shown, but the filter may comprise any appropriate number of taps. If the operator \mathcal{H} is set to 1 and the operator \mathcal{B} is set to $\mu(e(n))$, a leaky least mean square algorithm is achieved. If λ is set to 1, a simple least mean square algorithm is achieved. If \mathcal{H} is set to 1 and \mathcal{B} is set to $\mu \text{sgn}(e(n))$, a leaky sign least mean square algorithm is achieved. Finally \mathcal{H} may be set to $\text{sgn}(u_i(n))$ and \mathcal{B} may be set to $\mu \text{sgn}(e(n))$ thus achieving a leaky sign-sign LMS algorithm. The filter coefficients may also be calculated using recursive least square algorithms.

[0079] A warped FIR filter embodiment of the filter 10 is shown in more detail in Fig. 7. It should be noted that the circuitry below the upper delay line in Fig. 6 and in Fig. 7 are identical. It is preferred that the warping parameter γ is equal to 0.5. It should be noted that for $\gamma = 0$, the warped FIR filter turns into a FIR filter.

[0080] Fig. 8 shows a plot of the infinite impulse response of a warped FIR filter and the finite response of a FIR filter. The plot indicates that a warped FIR filter inherently has a better capability of approximating a desired transfer function than a FIR filter.

[0081] Fig. 9 shows a blocked diagram of a test circuit 100 for determination of the transfer function H_a of an adaptive filter 102 adapting to a desired transfer function H of another filter 104. The plotted curves shows the power spectrum 108 of the error signal 106 when the adaptive filter 102 is a warped FIR filter together with the power spectrum 110 of the error signal 106 when the adaptive filter 102 is a FIR filter. The FIR filter and the warped FIR filter have the same number of taps. It is seen that below 6-7 kHz the warped FIR filter improves the error signal by up to 15 dB. Since the output of the output transducer 5 typically has a cut-off frequency around 6-8 kHz, the performance of the warped FIR filter above 8 kHz is unimportant. It should be noted that changes in the sampling frequency will shift the frequency values indicated along the frequency axis. It is also noted that γ may be adjusted for optimising the spectrum of the error signal 106 for a specific application, such as a specific type of hearing deficiency.

[0082] Fig. 2 shows a multichannel embodiment of a hearing aid according to the present invention in which each channel generally operates in the same way as the single channel embodiment shown in Fig. 1. Corresponding parts of Fig. 1 and Fig. 2 are referenced by the same reference numbers except that indexes are added to the reference numbers of Fig. 2. For simplicity only three channels are indicated in Fig. 2. It should be noted, however, that the hearing aid may contain any appropriate number of channels as also indicated in the figure.

[0083] The multichannel embodiment of the invention according to Fig. 2 comprises the same parts as the single channel embodiment shown in Fig. 1 in addition to a filter bank 3 that outputs bandpass filtered signals 4a, 4i, 4n. In combining nodes 9a, 9i, 9n the respective signals 4a, 4i, 4n are combined to form respective signals 86a, 86i, 86n. The signals 86a, 86i, 86n are fed to the multichannel digital processor 7 for processing according to a desired characteristic that matches the hearing deficiency of the user. This may involve adjustment of different gain settings in the individual channels. Further the processing may also involve compressor functions. Still further, other functions such as noise reduction may be performed by the signal processor.

[0084] The output signal from the digital signal processor 7 is fed to a filter bank 16 where it is split into bandpass filtered signals 83a, 83i, 83n corresponding to the different frequency bands or channels in the set of adaptive filters 10a, 10i, 10n. Preferably, the filter bank 16 comprises a digital fourth order filter.

[0085] From the adaptive filter 10a, 10i, 10n the filtered signals 85a, 85i, 85n are fed to the respective combining nodes 9a, 9i, 9n for subtraction from the signals 4a, 4i, 4n and generation of the signals 86a, 86i, 86n. As in the

embodiment of Fig. 1, an optional delay line Δ may delay the output signal 80. Preferably, the delay is substantially equal to the maximum propagation time of sound from the output transducer 5 to the input transducer 1.

[0086] The processor 7 combines the signals of its channels into a single output signal 80.

[0087] In a multichannel embodiment, the adaptation rates of the respective channels may be different from each others. Thus, it is possible to apply higher adaptation rates with the resulting undesired distortion at frequencies where feedback resonance is likely to occur. This is an advantageous feature if feedback resonance occurs at frequencies that are unimportant to desired signals.

[0088] Further, signal detection is more difficult to perform in a broad frequency range. Thus, a multichannel system is less likely to produce convergence errors due to incorrect signal detection than a single channel system.

[0089] In one embodiment, the controller 13 controls the adaptation rate of the filter coefficients in the adaptive filter 10, 10a, 10i, 10n as a function of the actual operating gains in the processor in a gain interval from G_0 to G_a .

[0090] The hearing aid illustrated in Fig. 3 corresponds to the hearing aid of Fig. 1 with an added measuring system. Corresponding parts are referenced by identical reference numbers and explanation of their operation is not repeated. The hearing aid shown in Fig. 3 further comprises a second adaptive filter 11 operating in parallel with, i.e. on the same signals as, the first adaptive filter 10 but with a second convergence rate that is lower than the first convergence rate of the first adaptive filter 10. The output 85 of the second adaptive filter 11 are fed to the combining node 9 for subtraction from the signal 4 and generation of the signal 86 input to the processor 7 whereby the acoustic feedback signal is substantially removed from the signal before processing by the processor 7. It should be noted that the output 89 of the first adaptive filter 10 is not used for modification of the processor input.

[0091] In this embodiment, the controller 13 is adapted to estimate the amount of acoustic feedback by determination of a parameter of the first adaptive filter 10. The high first convergence rate allows the first adaptive filter 10 to track the acoustic feedback more closely over time than the second adaptive filter 11. Further, since the output signal 89 of the first adaptive filter 10 is not subtracted from the input transducer signal 4, the desired signal is not distorted by the first adaptive filter 10.

[0092] The second adaptive filter 11 may be any kind of adaptive filter, but is preferably a FIR filter or a warped FIR filter using a power-normalised Least Mean Square (power-nLMS) algorithm.

[0093] The second adaptive filter 11 outputs a filtered signal 89 to a second combining node 12 where it is combined with the signal 86 from the first combining node 9. The output signal 90 from the combining node 12 is input to the second adaptive filter 11 for adjustment of the filter coefficients.

[0094] It is an important advantage of the embodiment shown in Fig. 3 that the output signal generated by the first adaptive filter 10 is not fed into the main signal path from the input transducer 1 to the output transducer 5. The main signal path comprises the input transducer 1, the digital conversion means (not shown), the combining node 9, the digital processor 7 and the output transducer 5. Consequently, the signal processing by the first adaptive filter 10 does not affect the signal in the main signal path directly. Thus, no signal distortion of signals in the main signal path is created by the first adaptive filter 10, and thus the adaptation rate of the first adaptive filter 10 may be substantially higher than that of the second adaptive filter 11. Since the adaptation rate of the first adaptive filter 10 may be significantly higher than that of the second adaptive filter 11, the feedback path can be monitored much more closely over time for changes by the first adaptive filter 10 than by the second adaptive filter 11. Preferably the first adaptation rate is a fixed high adaptation rate, but the adaptation rate may be adjusted, e.g. by modifying one or more of the scaling factors. For example, it may be preferred to adjust the adaptation rate of the first adaptive filter in accordance with the actual gain in the processor or the input power level.

[0095] Adjustment of adaptation rate may differ for different modes of operation.

[0096] If rapid changes in the acoustic environment occur, the second adaptive filter 11 of Fig. 3 will not be able to immediately adapt to and compensate for the changes. Accordingly, uncompensated feedback signals will start to emerge. The first adaptive filter 10, however, is much faster than the second adaptive filter 11 and will adapt to the change in the feedback path.

[0097] In one embodiment, the controller controls the adaptation rate in the second adaptive filter 11, e.g. controlling the value of μ , based on the rapid response of the first adaptive filter 10 to changes in the feedback path. Thus, if the properties, e.g. the filtering characteristics, such as the attenuation, etc, of the first adaptive filter 10 indicate a change in the feedback path, the second adaptive filter 11 is controlled accordingly, i.e. by increasing the adaptation rate of the second adaptive filter 11 if the gain is close to the feedback limit. The increased adaptation rate of the second adaptive filter 11 allows it to compensate for the change in acoustic feedback more rapidly, e.g. before the acoustic feedback leads to generation of undesired sounds.

[0098] It should be noted that the amount of acoustic feedback may be estimated preferably by determination of a parameter of the first adaptive filter 10 or, alternatively or additionally, by determination of a parameter of the second adaptive filter 11. For example, the ratio between the input and the output signal of the respective adaptive filter 10, 11 may be determined since the ratio constitutes an estimate of the attenuation of the feedback path including the acoustical feedback path. Further, it may be desirable to base such a calculation on averaged signals thereby sup-

pressing influence from noise and speech and convergence errors. Alternatively an average of the desired properties may be determined. Preferably, a power estimate of the above-mentioned type is used for each signal. Alternatively, a parameter of one of the adaptive filters 10, 11 may be determined by appropriate transformation of the filter coefficients.

5 **[0099]** In another embodiment, the controller lowers the gain in the digital processor if a change in feedback is detected by the first adaptive filter 10. In particular this may be performed selectively in the different channels of the digital processor.

[0100] Based on the determination of the first parameter, the controller may calculate a maximum gain value G_{\max} that the processor is not allowed to exceed in order to avoid generation of undesired sound signals. In a multichannel hearing aid there may be an individual G_{\max} -value for each channel.

10 **[0101]** In yet another embodiment, the controller changes the gain interval from G_0 to G_a . Thus, if the second adaptive filter 11 detects that the system is close to instability, this information may be used to lower the lower gain limit G_0 thereby shifting the whole gain interval downwards or expanding the gain interval if it is desired to keep G_a at a specific level. If only the lower gain limit G_0 is changed the curves for λ and μ will preferably be changed so as to cover the different interval.

15 **[0102]** In this respect it should be noted that the relation between the gain and λ and μ may be different from the functions depicted in Fig. 10.

[0103] Fig. 4 shows a multichannel embodiment of a hearing aid according to the present invention in which each channel generally operates in the same way as the single channel embodiment shown in Fig. 3. Corresponding parts of Fig. 3 and Fig. 4 are referenced by the same reference numbers except that indexes are added to the reference numbers of Fig. 3. For simplicity only three channels are indicated in Fig. 4. It should be noted, however, that the hearing aid may contain any appropriate number of channels as also indicated in the figure. For simplicity, control lines have been omitted in Fig. 4.

20 **[0104]** The multichannel embodiment of the invention according to Fig. 4 comprises the same parts as the single channel embodiment shown in Fig. 3 in addition to a filter bank 16 that outputs bandpass filtered signals 83a, 83i, 83n to a second set of adaptive filters 11a, 11i, 11n. The respective adaptive filters 11a, 11i, 11n provide filtered signals to respective combining nodes 12a, 12i, 12n for combination with respective signals 86a, 86i, 86, from the combining nodes 9a, 9i, 9n.

25 **[0105]** The multichannel embodiment shown in Fig. 4 provides a more detailed estimation of the transfer function of the feedback path. Moreover, signal processing may be performed at lower sampling frequencies in lower frequency bands, a technique known as decimation. Decimation is particularly simple to use in the first set of adaptive filters since no anti-aliasing filter is needed in the system because the output signals from these filters are not fed into the main signal path.

30 **[0106]** The embodiment shown in Fig. 4 may be controlled in the same way as the embodiment shown in Fig. 3. However, the embodiment shown in Fig. 4 allows selective reduction of the gain in each individual channel and selective adjustment of the adaptation rate of each individual adaptive filter of the second set of adaptive filters 11a, 11i, 11n. This has the further advantage that the gain may be maintained at a high value and the distortion may be maintained at a low level at frequencies where feedback resonance is not likely to occur.

35 **[0107]** Fig. 5 shows a multichannel embodiment that is similar to and operates in a similar way as the embodiment shown in Fig. 4. However, the embodiment shown in Fig. 5 is simpler since it has a second set of adaptive filters that consists of a single adaptive filter 11 and also, the combining node 9 is a single combining node.

40 **[0108]** Many other embodiments may be provided with varying numbers of channels in the processor and the first and second sets of adaptive filters. Also the number of channels in the processor may be different from the number of filters in the first set of adaptive filters that again may be different from the number of filters in the second set of adaptive filters.

45 **[0109]** In particular it is possible to provide a digital signal processor 7 having relatively few channels and a second set of adaptive filters containing more filters. Alternatively, the individual adaptive filters of the second set of filters may operate on a combination of channels in the digital signal processor 7, e.g. two or more channels in the digital signal processor 7 may operate with the same G_{\max} determined by a specific adaptive filter of the first set of adaptive filters or, a channel in the digital signal processor 7 may operate with a G_{\max} that is the lowest gain of two or more gains determined by adaptive filters of the first set of adaptive filters. At present, however, the embodiment with a single second adaptive filter 11 and a multichannel first set of adaptive filters 10 is preferred.

50 **[0110]** In Fig. 11, a plot of operating gains as a function of frequency is shown. The upper solid curve shows the maximum operating gain that can be obtained with a hearing aid according to the present invention without generation of undesired sounds, and the lower dashed curves shows the corresponding gain for a known hearing aid.

Claims

1. A hearing aid comprising

5 an input transducer (1) for transforming an acoustic input signal into a first electrical signal (4),
 a first filter bank (3) with bandpass filters for dividing the first electrical signal (4) into a set of bandpass filtered
 first electrical signals (4_i),
 10 a processor (7) for generation of a second electrical signal (80) by individual processing of each of the bandpass
 filtered first electrical signals (4_i, 86) and adding the processed electrical signals into the second electrical
 signal (80),
 an output transducer (5) for transforming the second electrical signal (80) into an acoustic output signal (6),
 15 a second filter bank (16) with bandpass filters for dividing the second electrical signal (80) into a set of bandpass
 filtered second electrical signals (80_i),
 a first set of adaptive filters (10) with first filter coefficients for estimation of acoustic feedback by generation
 of third electrical signals (85) by filtering of the bandpass filtered second electrical signals (80_i) and adapting
 20 the respective third signals (85) to respective signals on the input side of the processor (7) with respective
 first convergence rates, and
 a controller that is adapted to compensate for acoustic feedback by determination of a first parameter of an
 25 acoustic feedback loop of the hearing aid and adjustment of a second parameter of the hearing aid in response
 to the first parameter whereby generation of undesired sounds is substantially avoided.

2. A hearing aid according to claim 1, wherein at least one of the adaptive filters of the first set of adaptive filters (10)
 30 operates on a respective decimated bandpass filtered second electrical signal (80_i).

3. A hearing aid according to claim 1 or 2, wherein the first filter bank (3) consists of a single bandpass filter.

4. A hearing aid according to claim 1 or 3, wherein the second filter bank (16) consists of a single bandpass filter,
 and the first set of adaptive filters consists of a single adaptive filter.
 35

5. A hearing aid according to claim 1 or 2, wherein the bandpass filters of the second filter (16) bank are substantially
 identical to respective bandpass filters of the first filter bank (3).

6. A hearing aid according to claim 4, wherein the first set of adaptive filters filters the second electrical signal (80)
 and adapts to the first electrical signal (4).
 40

7. A hearing aid according to claim 6, further comprising a combining node (9) for subtraction of the third signal (85)
 from the first electrical signal (4), and wherein the subtracted signal is fed to the processor (7).

8. A hearing aid according to claim 5, wherein the first set of adaptive filters filters the respective bandpass filtered
 second electrical signals (80_i) and adapts to the respective bandpass filtered first electrical signals (4_i).
 45

9. A hearing aid according to claim 8, further comprising a combining node (9) for subtraction of the third signals (85)
 from the respective bandpass filtered first electrical signals (4_i), and wherein the subtracted signals are fed to the
 processor (7).
 50

10. A hearing aid according to claim 6, further comprising

55 a second adaptive filter (11) with second filter coefficients for suppression of feedback in the hearing aid by
 filtering the second electrical signal (80) into a fourth electrical signal (85),
 a combining node (9) for generation of a fifth electrical signal (86) by subtraction of the fourth electrical signal
 (85) from the first electrical signal (4) and for feeding the fifth electrical signal (86) to the respective bandpass

filters of the first filter bank, and wherein the second filter coefficients are updated with a second convergence rate that is lower than the first convergence rate.

5 11. A hearing aid according to claim 8, further comprising

a set of second adaptive filters (11) with second filter coefficients for suppression of feedback in the hearing aid by filtering the bandpass filtered second electrical signals (80_i) into respective fourth electrical signals (85_i),

10 a combining node (9) for generation of fifth electrical signals (86_i) by subtraction of the fourth electrical signals (85_i) from the respective bandpass filtered first electrical signals (4_i) and for feeding the fifth electrical signals (86_i) to the processor (7), and wherein the second filter coefficients are updated with a second convergence rate that is lower than the first convergence rate.

15 12. A hearing aid according to any of the preceding claims, wherein the first parameter is an operating gain of the processor (7).

13. A hearing aid according to any of claims 1-11, wherein the first parameter is a parameter of the first set of adaptive filters.

20 14. A hearing aid according to claim 13, wherein the first parameter is the ratio between the magnitude of a signal (88) at an input of a first adaptive filter of the first set of adaptive filters (11) and the magnitude of a signal (89) at the corresponding output.

25 15. A hearing aid according to any of the preceding claims, wherein the second parameter is a gain of the processor (7).

16. A hearing aid according to any of claims 1-14, wherein the second parameter is the first convergence rate of the first filter coefficients.

30 17. A hearing aid according to any of claims 12-16 as dependent on claim 9 or 10, wherein the second parameter is the second convergence rate of the second filter coefficients.

18. A hearing aid according to any of the preceding claims, further comprising means for updating filter coefficients according to a leaky least mean square algorithm:

$$35 \quad c_i(n+1) = \lambda(c_i(n)-c_i(0)) + c_i(0) + \mu u_i(n)e(n)$$

40 where $c_i(n+1)$ is the updated value of i 'th filter coefficient, $c_i(n)$ is the current value of the i 'th filter coefficient, $c_i(0)$ is the initial value of the i 'th filter coefficient, $u_i(n)$ is the $(n-i)$ 'th sample of the processor output signal, $e(n)$ is the current sample of the second electrical signal (86), λ is the leakage, and μ is the convergence, λ and μ determining the first convergence rate.

45 19. A hearing aid according to any of the preceding claims, further comprising means for updating filter coefficients according to a normalised Least Mean Square:

$$\underline{c}(n+1) = \lambda(\underline{c}(n) - \underline{c}(0)) + \underline{c}(0) + \mu \frac{\underline{u}(n)}{\underline{u}(n) \cdot \underline{u}(n)} e(n)$$

50 where $\underline{u}(n)$ is an N dimensional vector containing the latest N samples of the signal u , $\underline{c}(n)$ is a vector containing the current values of the N filter coefficients, $\underline{c}(0)$ is a vector containing the initial values of the N filter coefficients, $\underline{c}(n+1)$ is the updated values of the N filter coefficients, and $e(n)$ is the current sample of the second electrical signal (86).

55 20. A hearing aid according to any of the preceding claims, further comprising means for updating filter coefficients according to a power normalised Least Mean Square algorithm.

EP 1 191 814 A1

$$P_u(t+T) = \alpha P_u(t) + (1-\alpha)u^2(t)$$

where α is a predetermined constant that determines the rate with which the P_u estimate changes.

- 5
21. A hearing aid according to any of the preceding claims, further comprising means for updating filter coefficients according to a leaky sign least mean square algorithm:

$$10 \quad c_i(n+1) = \lambda(c_i(n)-c_i(0)) + c_i(0) + \mu_s u_i(n)$$

where $c_i(n+1)$ is the updated value of i 'th filter coefficient, $c_i(n)$ is the current value of the i 'th filter coefficient, $c_i(0)$ is the initial value of the i 'th filter coefficient, $u_i(n)$ is the $(n-i)$ 'th sample of the processor output signal, $e(n)$ is the current sample of the second electrical signal (86), λ is the leakage, and μ is the convergence, and μ_s is the sign of the $e(n)$ signal multiplied by μ , λ and μ determining the first convergence rate.

- 15
22. A hearing aid according to any of the preceding claims, further comprising means for updating filter coefficients according to a leaky sign-sign least mean square algorithm:

$$20 \quad c_i(n+1) = \lambda(c_i(n)-c_i(0)) + c_i(0) + \mu_s \operatorname{sgn}(u_i(n))$$

where $c_i(n+1)$ is the updated value of i 'th filter coefficient, $c_i(n)$ is the current value of the i 'th filter coefficient, $c_i(0)$ is the initial value of the i 'th filter coefficient, $u_i(n)$ is the $(n-i)$ 'th sample of the processor output signal, $e(n)$ is the current sample of the second electrical signal (86), λ is the leakage, and μ is the convergence factor, and $\operatorname{sgn}(u_i(n))$ is the sign of $u_i(n)$, λ and μ determining the first convergence rate.

- 25
23. A hearing aid according to any of the preceding claims, wherein at least one of the first and second sets of adaptive filters (10, 11) comprises a finite impulse response filter.

- 30
24. A hearing aid according to any of the preceding claims, wherein at least one of the first and second sets of adaptive filters (10, 11) comprises a warped finite impulse response filter.

- 35
25. A hearing aid according to any of the preceding claims, wherein the controller is adapted to adjust a second parameter of the hearing aid in response to the first parameter and in response to the actual acoustic environment.

- 40
26. A hearing aid comprising

an input transducer (1) for transforming an acoustic input signal into a first electrical signal (4),

45
a processor (7) for generation of a second electrical signal (80) by processing of the first electrical signals (4, 86) into the second electrical signal (80),

an output transducer (5) for transforming the second electrical signal (80) into an acoustic output signal (6),

50
an adaptive filter (10) with filter coefficients for estimation of acoustic feedback by generation of third electrical signals (85) by filtering of the second electrical signal (80) and adapting the respective third signals (85) to respective signals on the input side of the processor (7),

55 **characterised in that**

the adaptive filter (10) is a warped adaptive filter.

27. A hearing aid according to claim 26, wherein the warped filter is a warped FIR filter.

- 55
28. A method of suppressing acoustic feedback in a hearing aid, comprising the steps of:

transforming an acoustic input signal into a first electrical signal (4),

EP 1 191 814 A1

dividing the first electrical signal (4) into a set of bandpass filtered first electrical signals (4_i),

processing each of the bandpass filtered first electrical signals (4_i, 86) individually,

5

adding the processed electrical signals into a second electrical signal (80),

transforming the second electrical signal (80) into an acoustic output signal (6),

10

dividing the second electrical signal (80) into a set of bandpass filtered second electrical signals (80_i),

estimating acoustic feedback by generation of third electrical signals (85) by adaptive filtering of the bandpass filtered second electrical signals (80_i) and adapting the filtered signals (85) to respective signals on the input side of the processor (7) with respective first convergence rates, and

15

compensating for acoustic feedback by

 determining a first parameter of an acoustic feedback loop of the hearing aid, and

 adjusting a second parameter of the hearing aid in response to the first parameter

20

whereby generation of undesired sounds is substantially avoided.

25

30

35

40

45

50

55

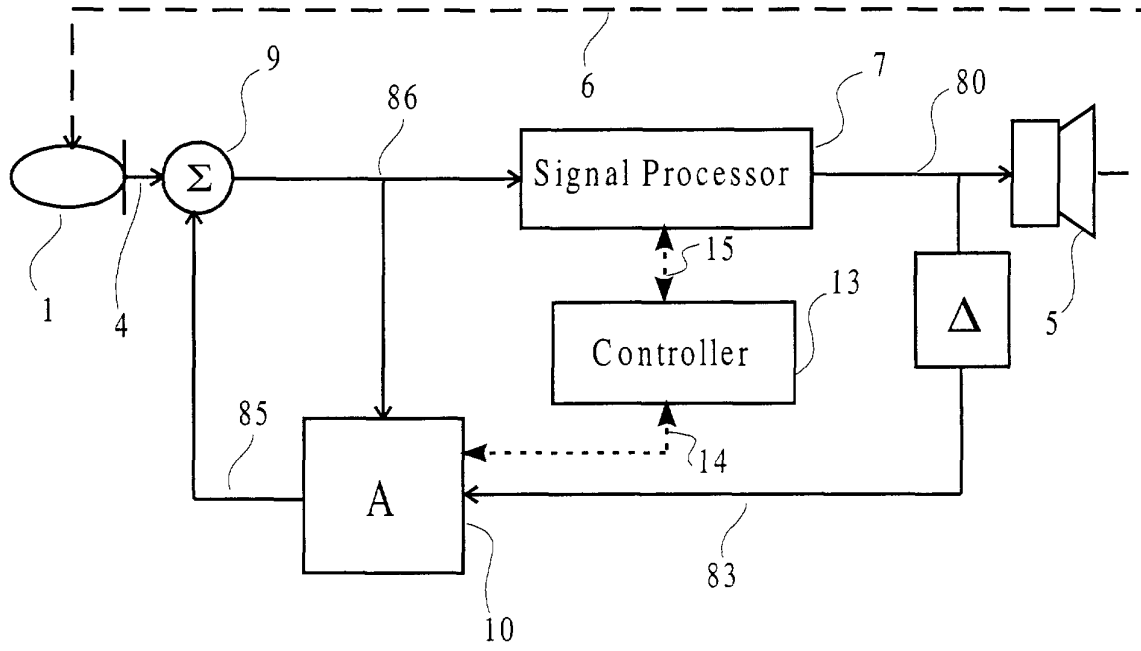

Figure 1

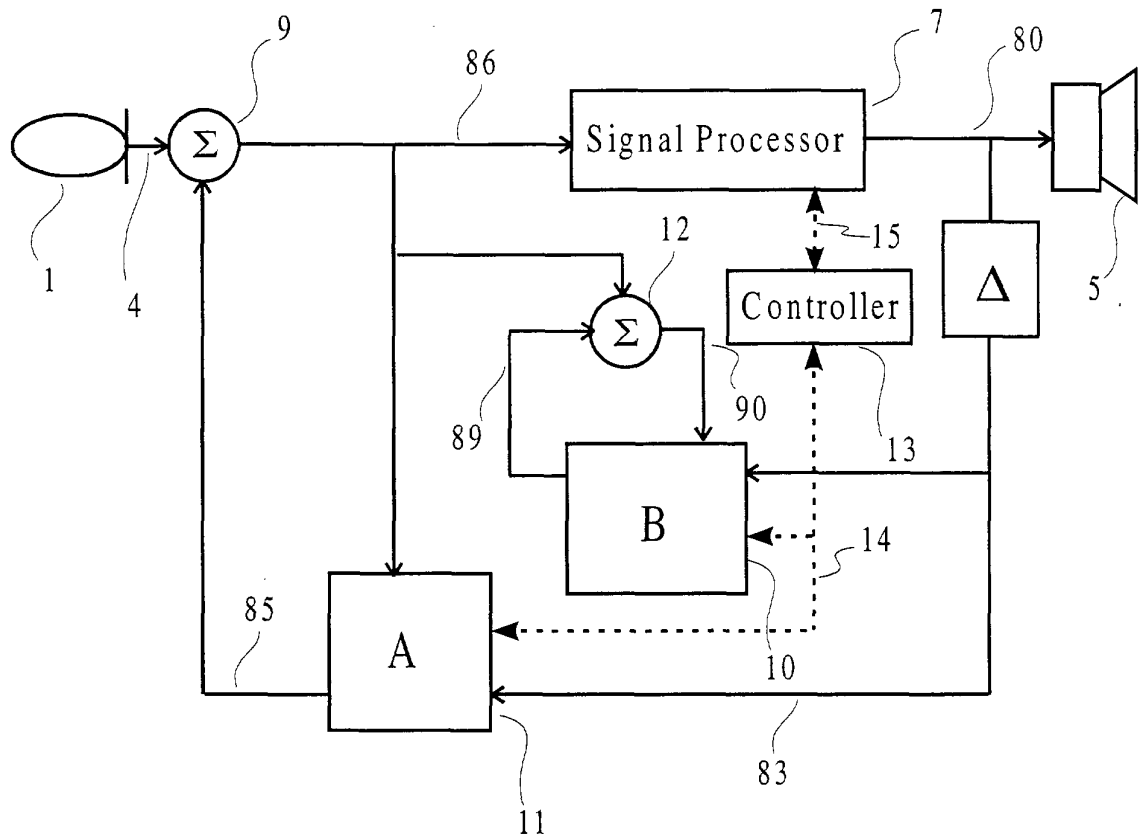

Figure 3

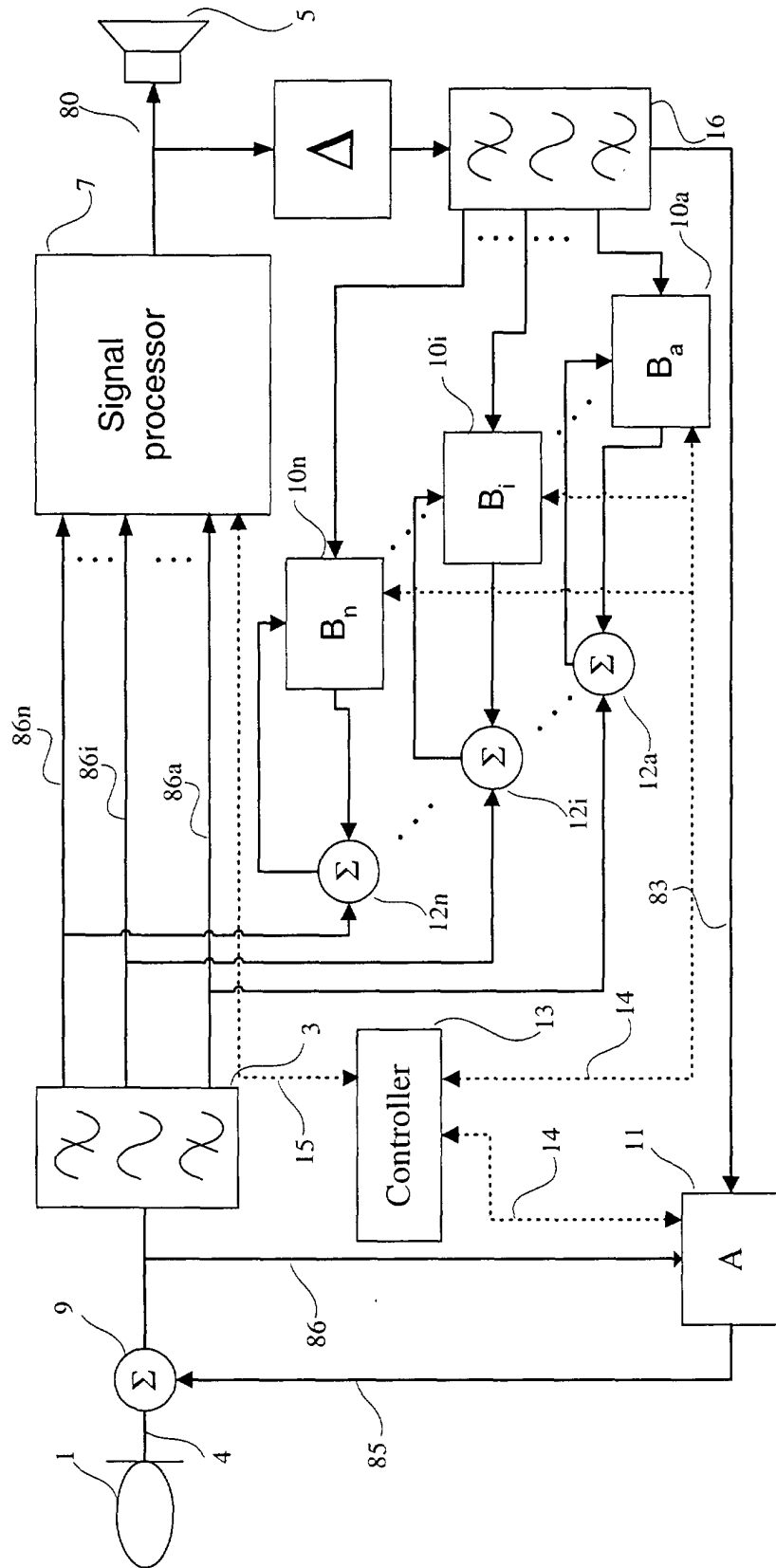

Figure 5

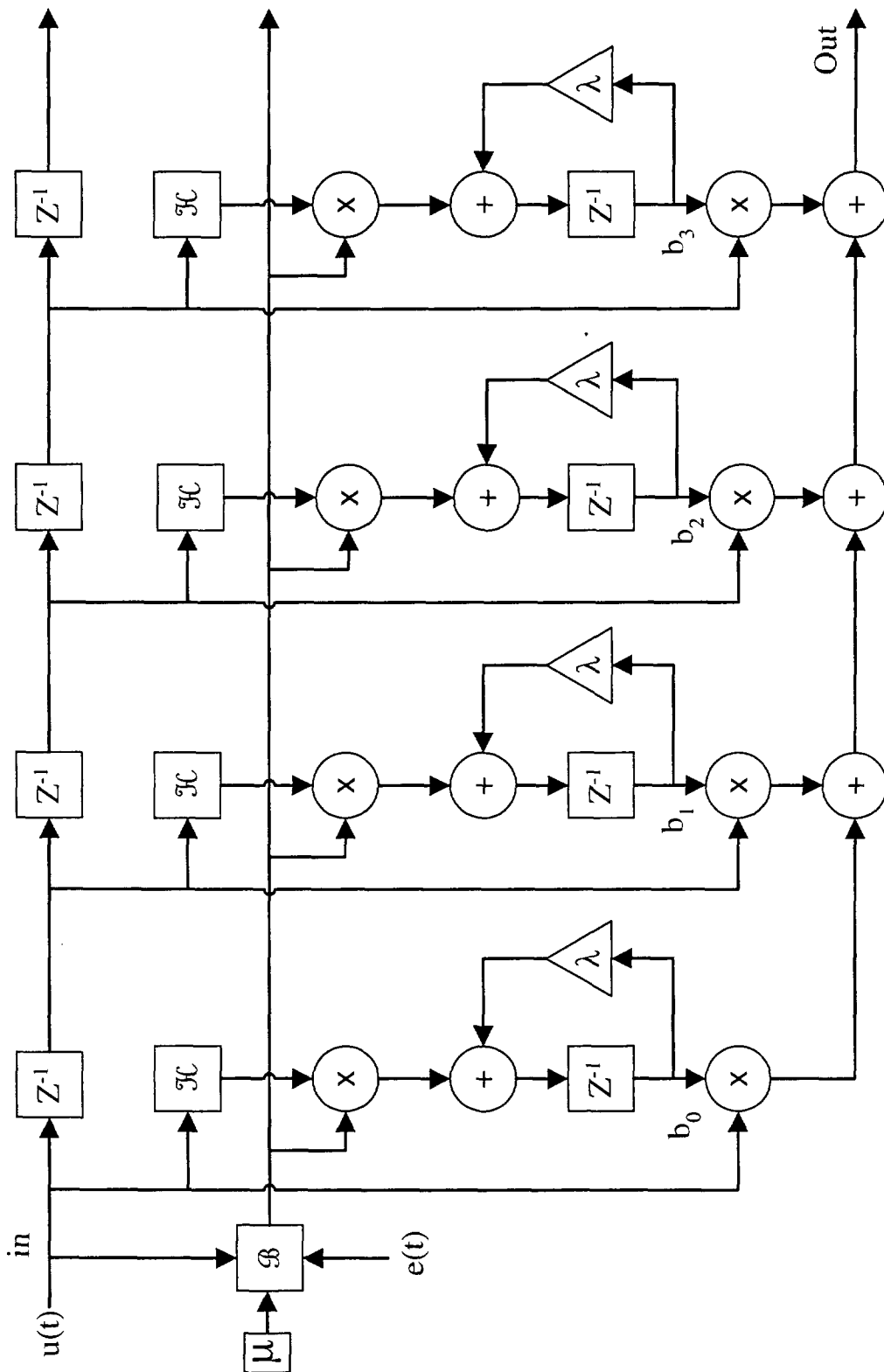

Figure 6

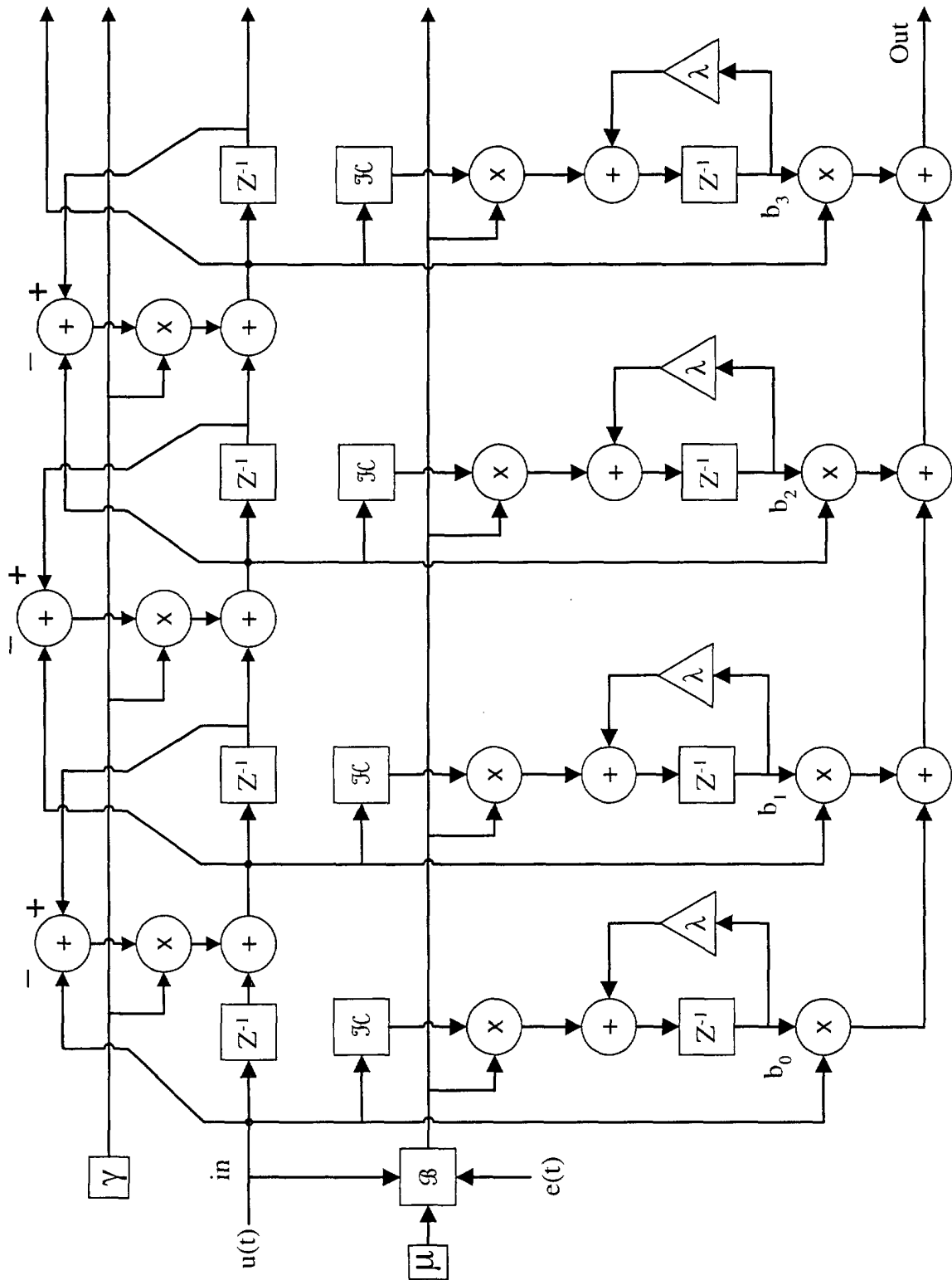

Figure 7

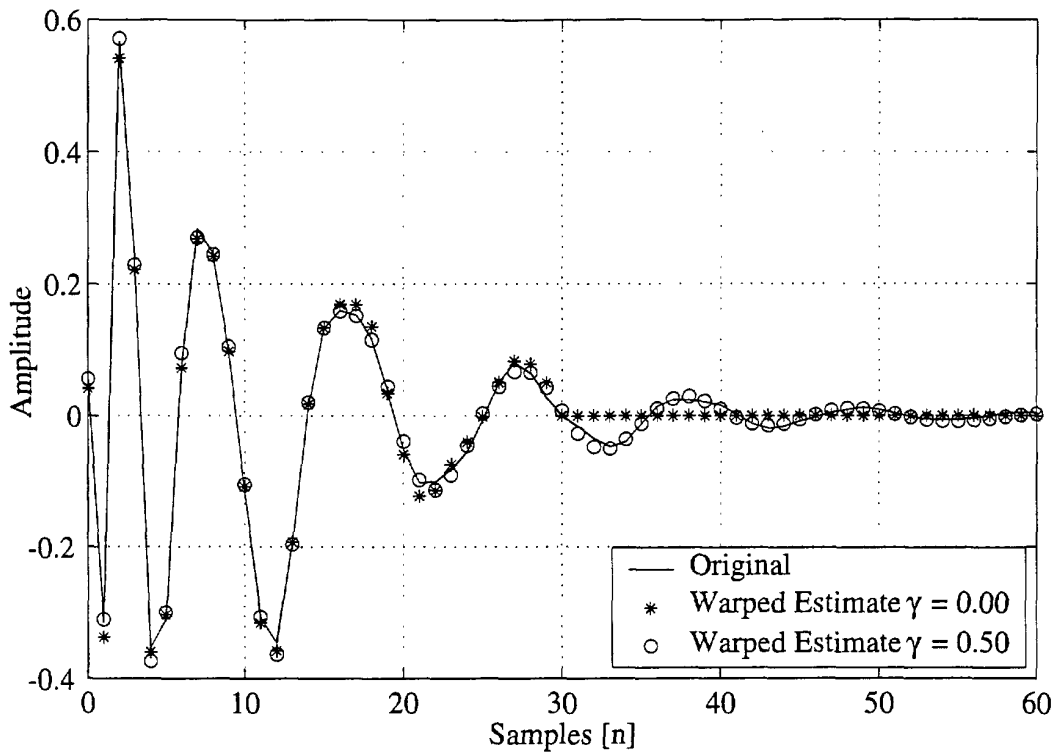

Figure 8

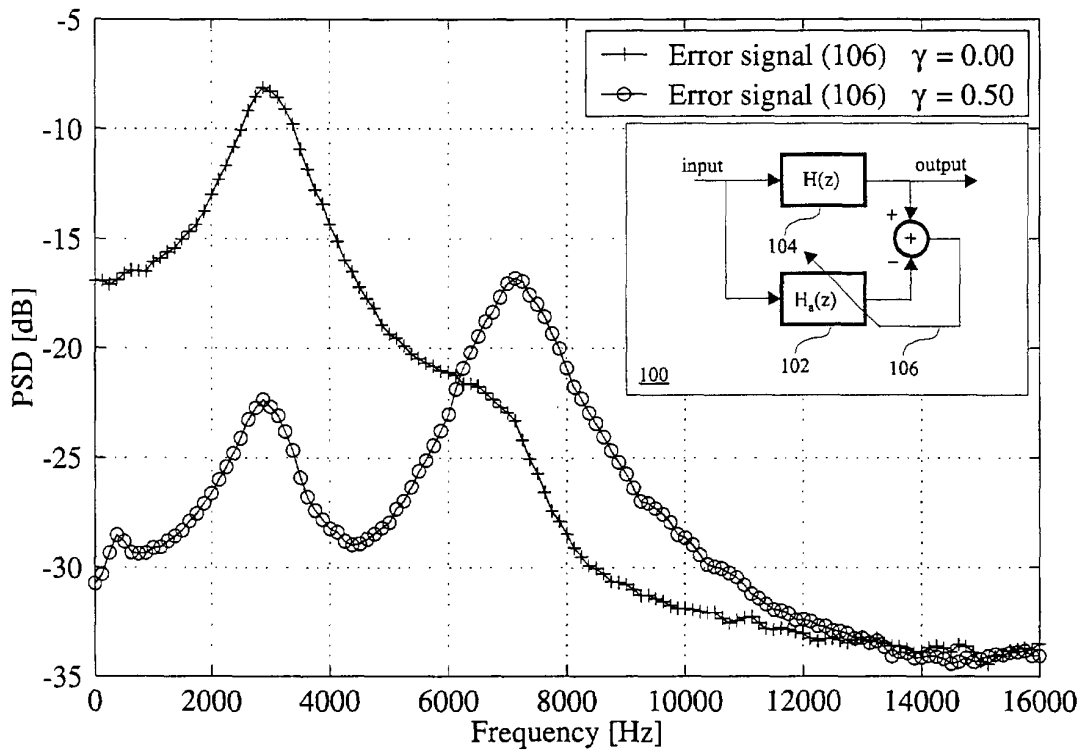

Figure 9

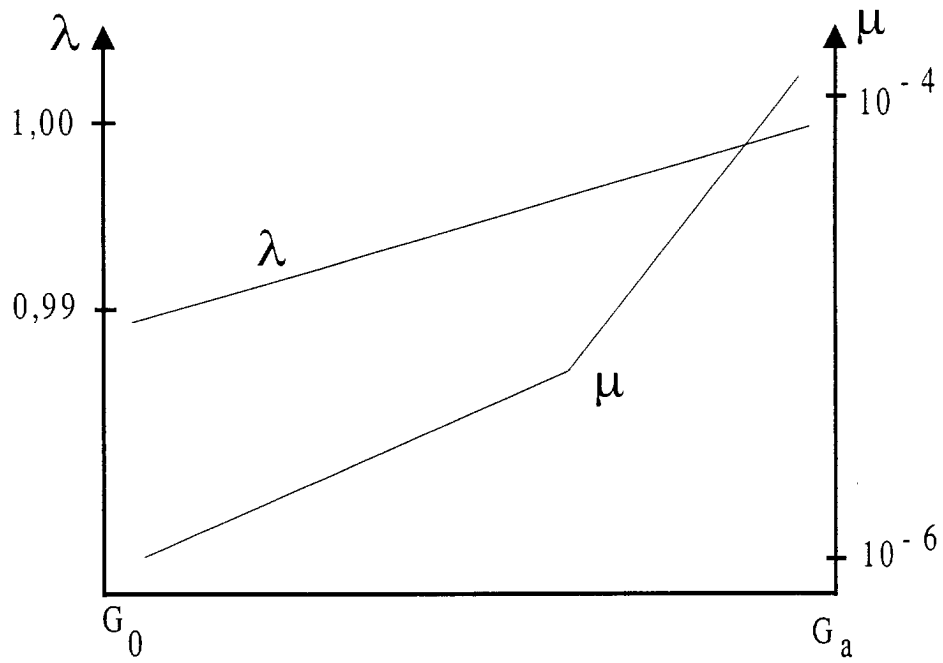

Figure 10

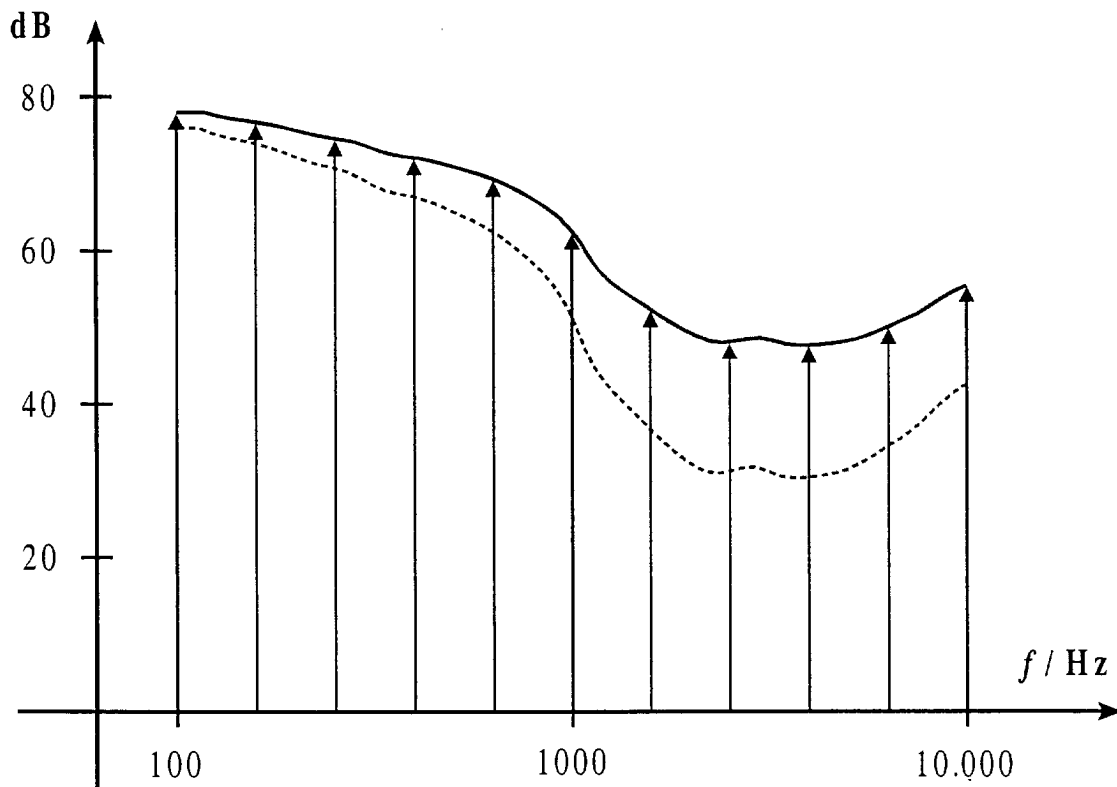

Figure 11



European Patent Office

EUROPEAN SEARCH REPORT

Application Number
EP 00 61 0124

DOCUMENTS CONSIDERED TO BE RELEVANT			
Category	Citation of document with indication, where appropriate, of relevant passages	Relevant to claim	CLASSIFICATION OF THE APPLICATION (Int.Cl.7)
A	WO 98 47313 A (BRENNAN ROBERT ;DSP FACTORY LTD (CA); SCHNEIDER ANTHONY TODD (CA)) 22 October 1998 (1998-10-22) * page 6, line 22 - page 14, line 3; figures *	1,28	H04R25/00 H04R3/02
A	LUNNER T ET AL: "A DIGITAL FILTERBANK HEARING AIDDESIGN, IMPLEMENTATION AND EVALUATION" INTERNATIONAL CONFERENCE ON ACOUSTICS, SPEECH & SIGNAL PROCESSING. ICASSP,US,NEW YORK, IEEE, vol. CONF. 16, 14 May 1991 (1991-05-14), pages 3661-3664, XP000242759 ISBN: 0-7803-0003-3 * the whole document *	1,28	
A	US 5 500 902 A (CHABRIES DOUGLAS M ET AL) 19 March 1996 (1996-03-19) * column 4, line 25 - column 6, line 6; figures *	1,28	
A	WO 98 56210 A (AUDIOLOGIC HEARING SYS LP) 10 December 1998 (1998-12-10) * page 10, line 5 - page 15, line 19; figures *	1,28	
A	EP 0 814 639 A (AUDIOLOGIC INC) 29 December 1997 (1997-12-29) * column 4, line 1 - line 8 * * column 7, line 34 - line 49 *	26,27	
-/--			TECHNICAL FIELDS SEARCHED (Int.Cl.7)
			H04R
The present search report has been drawn up for all claims			
Place of search		Date of completion of the search	Examiner
THE HAGUE		19 December 2001	Gastaldi, G
CATEGORY OF CITED DOCUMENTS			
X : particularly relevant if taken alone Y : particularly relevant if combined with another document of the same category A : technological background O : non-written disclosure P : intermediate document		T : theory or principle underlying the invention E : earlier patent document, but published on, or after the filing date D : document cited in the application L : document cited for other reasons & : member of the same patent family, corresponding document	

EPO FORM 1503 03 02 (P04C01)



European Patent
Office

EUROPEAN SEARCH REPORT

Application Number
EP 00 61 0124

DOCUMENTS CONSIDERED TO BE RELEVANT			
Category	Citation of document with indication, where appropriate, of relevant passages	Relevant to claim	CLASSIFICATION OF THE APPLICATION (Int.Cl.7)
A	KARJALAINEN M ET AL: "COMPARISON OF LOUDSPEAKER EQUALIZATION METHODS BASED ON DSP TECHNIQUES" JOURNAL OF THE AUDIO ENGINEERING SOCIETY, AUDIO ENGINEERING SOCIETY, NEW YORK, US, vol. 47, no. 1/2, January 1999 (1999-01), pages 14-30, XP000823370 ISSN: 0004-7554 * page 15, paragraph 2 - page 17 *	26,27	
A	HARMA A: "Implementation of frequency-warped recursive filters" SIGNAL PROCESSING, AMSTERDAM, NL, vol. 80, no. 3, March 2000 (2000-03), pages 543-548, XP004188172 ISSN: 0165-1684 * page 544, paragraph 2 - page 545 *	26,27	
			TECHNICAL FIELDS SEARCHED (Int.Cl.7)
The present search report has been drawn up for all claims			
Place of search THE HAGUE		Date of completion of the search 19 December 2001	Examiner Gastaldi, G
CATEGORY OF CITED DOCUMENTS X : particularly relevant if taken alone Y : particularly relevant if combined with another document of the same category A : technological background O : non-written disclosure P : intermediate document		T : theory or principle underlying the invention E : earlier patent document, but published on, or after the filing date D : document cited in the application L : document cited for other reasons & : member of the same patent family, corresponding document	

EPO FORM 1503, 03.92 (P04G01)

**ANNEX TO THE EUROPEAN SEARCH REPORT
ON EUROPEAN PATENT APPLICATION NO.**

EP 00 61 0124

This annex lists the patent family members relating to the patent documents cited in the above-mentioned European search report. The members are as contained in the European Patent Office EDP file on
The European Patent Office is in no way liable for these particulars which are merely given for the purpose of information.

19-12-2001

Patent document cited in search report		Publication date	Patent family member(s)	Publication date
WO 9847313	A	22-10-1998	AU 6915398 A	11-11-1998
			WO 9847313 A2	22-10-1998
			EP 0985328 A2	15-03-2000
			JP 2001519127 T	16-10-2001
			NO 995009 A	10-12-1999
			US 6236731 B1	22-05-2001
			US 6240192 B1	29-05-2001
US 5500902	A	19-03-1996	AU 695115 B2	06-08-1998
			AU 3092895 A	09-02-1996
			CA 2194583 A1	25-01-1996
			EP 0770316 A1	02-05-1997
			WO 9602120 A1	25-01-1996
			US 5848171 A	08-12-1998
			US 6072885 A	06-06-2000
WO 9856210	A	10-12-1998	US 6097824 A	01-08-2000
			AU 7365898 A	21-12-1998
			EP 0986933 A1	22-03-2000
			WO 9856210 A1	10-12-1998
EP 0814639	A	29-12-1997	US 5771299 A	23-06-1998
			EP 0814639 A2	29-12-1997

EPO FORM P0459

For more details about this annex : see Official Journal of the European Patent Office, No. 12/82