

(19) World Intellectual Property Organization
International Bureau



(43) International Publication Date
13 February 2003 (13.02.2003)

PCT

(10) International Publication Number
WO 03/011131 A2

(51) International Patent Classification⁷: A61B 5/00

[US/US]; 12804 Amaranth Street, San Diego, CA 92129 (US). RHODES, Rathbun [US/US]; 6421 Bridge Road, Madison, WI 53713 (US).

(21) International Application Number: PCT/US02/23903

(22) International Filing Date: 26 July 2002 (26.07.2002)

(74) Agent: ALTMAN, Daniel, E.; Knobbe, Martens, Olson & Bear, LLP, 620 Newport Center Drive, Sixteenth Floor, Newport Beach, CA 92660 (US).

(25) Filing Language: English

(26) Publication Language: English

(81) Designated States (*national*): AE, AG, AL, AM, AT, AU, AZ, BA, BB, BG, BR, BY, BZ, CA, CH, CN, CO, CR, CU, CZ (utility model), CZ, DE (utility model), DE, DK (utility model), DK, DM, DZ, EC, EE (utility model), EE, ES, FI (utility model), FI, GB, GD, GE, GH, GM, HR, HU, ID, IL, IN, IS, JP, KE, KG, KP, KR, KZ, LC, LK, LR, LS, LT, LU, LV, MA, MD, MG, MK, MN, MW, MX, MZ, NO, NZ, OM, PH, PL, PT, RO, RU, SD, SE, SG, SI, SK (utility model), SK, SL, TJ, TM, TN, TR, TT, TZ, UA, UG, US, UZ, VN, YU, ZA, ZM, ZW.

(30) Priority Data:
09/916,711 27 July 2001 (27.07.2001) US

(71) Applicant (*for all designated States except US*): DEX-COM, INC. [US/US]; 6725 Mesa Ridge Road, Suite 100, San Diego, CA 92121 (US).

(72) Inventors; and

(84) Designated States (*regional*): ARIPO patent (GH, GM, KE, LS, MW, MZ, SD, SL, SZ, TZ, UG, ZM, ZW), Eurasian patent (AM, AZ, BY, KG, KZ, MD, RU, TJ, TM), European patent (AT, BE, BG, CH, CY, CZ, DE, DK, EE, ES, FI, FR, GB, GR, IE, IT, LU, MC, NL, PT, SE, SK,

(75) Inventors/Applicants (*for US only*): BRAUKER, James, H. [US/US]; 10831 Riesling Drive, San Diego, CA 92131 (US). SHULTS, Mark, C. [US/US]; 2810 Gregory Street, Madison, WI 53711 (US). TAPSAK, Mark, A.

[Continued on next page]

(54) Title: SENSOR HEAD FOR USE WITH IMPLANTABLE DEVICES

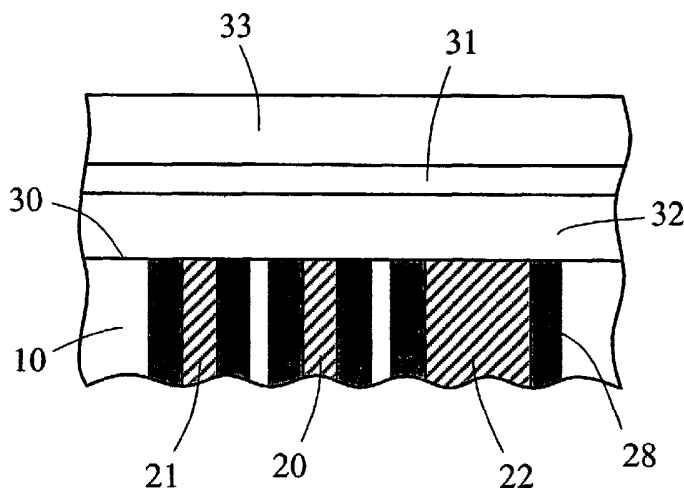

(57) Abstract: The present invention provides a sensor head (10) for use in an implantable device that measures the concentration of an analyte in a biological fluid which includes: a non-conductive body; a working electrode (21), a reference electrode (20) and a counter electrode (22), wherein the electrodes pass through the non-conductive body forming an electrochemically reactive surface at one location on the body and forming an electronic connection at another location on the body, further wherein the electrochemically reactive surface of the counter electrode (22) is greater than the surface area of the working electrode (21); and a multi-region membrane having a first region (33), a second region (31), and a third region (32), wherein the membrane is affixed to the nonconductive body and covering the working electrode (21), reference electrode (20) and counter electrode (22). In addition, the present invention provides an implantable device including at least one of the sensor heads (10) of the invention and methods of monitoring glucose levels in a host utilizing the implantable device of the invention.



WO 03/011131 A2



TR), OAPI patent (BF, BJ, CF, CG, CI, CM, GA, GN, GQ, GW, ML, MR, NE, SN, TD, TG).

For two-letter codes and other abbreviations, refer to the "Guidance Notes on Codes and Abbreviations" appearing at the beginning of each regular issue of the PCT Gazette.

Declaration under Rule 4.17:

— *of inventorship (Rule 4.17(iv)) for US only*

Published:

— *without international search report and to be republished upon receipt of that report*

SENSOR HEAD FOR USE WITH IMPLANTABLE DEVICES**FIELD OF THE INVENTION**

[0001] The present invention relates generally to novel sensor heads utilized with
5 implantable devices, devices including these sensor heads and methods for determining
analyte levels using these implantable devices. More particularly, the invention relates to
sensor heads, implantable devices including these sensor heads and methods for monitoring
glucose levels in a biological fluid using these devices.

BACKGROUND OF THE INVENTION

10 [0002] Amperometric electrochemical sensors require a counter electrode to
balance the current generated by the species being measured at the working electrode. In
the case of a glucose oxidase based glucose sensor, the species being measured at the
working electrode is H₂O₂. Glucose oxidase catalyzes the conversion of oxygen and
glucose to hydrogen peroxide and gluconate according to the following reaction:



[0003] Because for each glucose molecule metabolized, there is a proportional
change in the product H₂O₂, one can monitor the change in H₂O₂ to determine glucose
concentration. Oxidation of H₂O₂ by the working electrode is balanced by reduction of
ambient oxygen, enzyme generated H₂O₂, or other reducible species at the counter
20 electrode. *In vivo* glucose concentration may vary from about one hundred times or more
that of the oxygen concentration. Consequently, oxygen becomes a limiting reactant in the
electrochemical reaction and when insufficient oxygen is provided to the sensor, the sensor
will be unable to accurately measure glucose concentration. Those skilled in the art have
come to interpret oxygen limitations resulting in depressed function as being a problem of
25 availability of oxygen to the enzyme.

[0004] As shown in Fig. 1, the sensor head 10 includes a working electrode 21 (anode), counter electrode 22 (cathode), and reference electrode 20 which are affixed to the head by both brazing 26 the electrode metal to the ceramic and potting with epoxy 28. The working electrode 21 (anode) and counter-electrode 22 (cathode) of a glucose oxidase-based glucose sensor head 10 require oxygen in different capacities. Prior art teaches an enzyme-containing membrane that resides above an amperometric electrochemical sensor. In Fig. 1, region 32 includes an immobilized enzyme, *i.e.* glucose oxidase. Within the enzyme layer above the working electrode 21, oxygen is required for the production of H₂O₂ from glucose. The H₂O₂ produced from the glucose oxidase reaction further reacts at surface 21a of working electrode 21 and produces two electrons. The products of this reaction are two protons (2H⁺), two electrons (2e⁻), and one oxygen molecule (O₂) (Fraser, D.M. "An Introduction to *In vivo* Biosensing: Progress and problems." In "Biosensors and the Body," D.M. Fraser, ed., 1997, pp. 1-56 John Wiley and Sons, New York). In theory, the oxygen concentration near the working electrode 21, which is consumed during the glucose oxidase reaction, is replenished by the second reaction at the working electrode. Therefore, the net consumption of oxygen is zero. In practice, neither all of the H₂O₂ produced by the enzyme diffuses to the working electrode surface nor does all of the oxygen produced at the electrode diffuse to the enzyme domain.

[0005] With further reference to Fig. 1, the counter electrode 22 utilizes oxygen as an electron acceptor. The most likely reducible species for this system are oxygen or enzyme generated peroxide (Fraser, D.M. *supra*). There are two main pathways by which oxygen may be consumed at the counter electrode 22. These include a four-electron pathway to produce hydroxide and a two-electron pathway to produce hydrogen peroxide. The two-electron pathway is shown in Fig. 1. Oxygen is further consumed above the counter electrode by the glucose oxidase in region 32. Due to the oxygen consumption by

both the enzyme and the counter electrode, there is a net consumption of oxygen at the surface 22a of the counter electrode. Theoretically, in the domain of the working electrode there is significantly less net loss of oxygen than in the region of the counter electrode. In addition, there is a close correlation between the ability of the counter electrode to maintain
5 current balance and sensor function. Taken together, it appears that counter electrode function becomes limited before the enzyme reaction becomes limited when oxygen concentration is lowered.

[0006] Those practicing in the field of implantable glucose oxidase sensors have focused on improving sensor function by increasing the local concentration of oxygen in
10 the region of the working electrode. (Fraser, D.M. *supra*).

[0007] We have observed that in some cases, loss of glucose oxidase sensor function may not be due to a limitation of oxygen in the enzyme layer near the working electrode, but may instead be due to a limitation of oxygen at the counter electrode. In the presence of increasing glucose concentrations, a higher peroxide concentration results,
15 thereby increasing the current at the working electrode. When this occurs, the counter electrode limitation begins to manifest itself as this electrode moves to increasingly negative voltages in the search for reducible species. When a sufficient supply of reducible species, such as oxygen, are not available, the counter electrode voltage reaches a circuitry limit of -0.6V resulting in compromised sensor function (see Fig. 3).

[0008] Fig. 3 shows simultaneous measurement of counter-electrode voltage and
20 sensor output to glucose levels from a glucose sensor implanted subcutaneously in a canine host. It can be observed that as glucose levels increase, the counter electrode voltage decreases. When the counter electrode voltage reaches -0.6V, the signal to noise ratio increases significantly. This reduces the accuracy of the device. Fig. 4 shows a further
25 example of another glucose sensor in which the counter-electrode reaches the circuitry

limit. Again, once the counter electrode reaches -0.6V , the sensitivity and/or signal-to-noise ratio of the device is compromised. In both of these examples, glucose levels reached nearly 300 mg/dl . However, in Fig. 3 the sensor showed a greater than three-fold higher current output than the sensor in Fig. 4. These data suggest that there may be a limitation of
5 reducible species at the counter electrode, which may limit the sensitivity of the device as the glucose levels increase. In contrast, Fig. 5 shows a glucose sensor in which the counter electrode voltage did not reach -0.6V . In Fig. 5 it can be observed that the sensor was able to maintain a current balance between the working and counter electrodes, thereby enabling accurate measurements throughout the course of the experiment. The results shown in
10 Figures 3, 4 and 5 led the present inventors to postulate that by keeping the counter electrode from reaching the circuitry limit, one could maintain sensitivity and accuracy of the device.

[0009] Two approaches have been utilized by others to relieve the counter electrode limitation described above. The first approach involves the widening of the potential range
15 over which the counter electrode can move in the negative direction to avoid reaching circuitry limitations. Unfortunately, this approach increases undesirable products that are produced at lower potentials. One such product, hydrogen, may form at the counter electrode, which may then diffuse back to the working electrode. This may contribute to additional current resulting in erroneously high glucose concentration readings.
20 Additionally, at these increasingly negative potentials, the probability of passivating or poisoning the counter electrode greatly increases. This effectively reduces the counter electrode surface area requiring a higher current density at the remaining area to maintain current balance. Furthermore, increased current load increases the negative potentials eventually resulting in electrode failure.

[0010] The second approach is utilizing the metal case of the device as a counter electrode (*see* U.S. Patent No. 4,671,288, Gough or U.S. Patent No. 5,914,026, Blubaugh). This provides an initial excess in surface area which is expected to serve the current balancing needs of the device over its lifetime. However, when the counter electrode
5 reaction is a reduction reaction, as in Blubaugh, the normally present metal oxide layer will be reduced to bare metal over time leaving the surface subject to corrosion, poisoning, and eventual cascade failure. This problem is magnified when considering the various constituents of the body fluid that the metal casing is exposed to during *in vivo* use. To date, there has been no demonstration of long-term performance of such a device with this
10 counter electrode geometry.

Consequently, there is a need for a sensor that will provide accurate analyte measurements, that reduces the potential for cascade failure due to increasing negative potentials, corrosion and poisoning, and that will function effectively and efficiently in low oxygen concentration environments.

15 **SUMMARY OF THE INVENTION**

[0011] In one aspect of the present invention, a sensor head for use in a device that measures the concentration of an analyte in a biological fluid is provided that includes a non-conductive body; a working electrode, a reference electrode and a counter electrode, wherein the electrodes pass through the non-conductive body forming an electrochemically
20 reactive surface at one location on the body and forming an electronic connection at another location on the body, and further wherein the electrochemically reactive surface of the counter electrode is greater than the surface area of the working electrode; and a multi-region membrane affixed to the nonconductive body and covering the working electrode, reference electrode and counter electrode.

[0012] In another aspect of the present invention, a sensor head for use in an implantable analyte measuring device is provided which includes the same sensor head components as those described above.

[0013] The sensor heads of the present invention include a multi-region membrane that controls the number of species that are able to reach the surface of the electrodes. In particular, such a membrane allows the passage of desired substrate molecules (*e.g.* oxygen and glucose) and rejects other larger molecules that may interfere with accurate detection of an analyte. The sensor heads of the present invention also provide a larger counter electrode reactive surface that balances the current between the working and counter electrodes, thereby minimizing negative potential extremes that may interfere with accurate analyte detection.

[0014] In another aspect of the present invention, an implantable device for measuring an analyte in a biological fluid is provided including at least one of the sensor heads described above. In still another aspect of the present invention, a method of monitoring glucose levels is disclosed which includes the steps of providing a host, and an implantable device as provided above and implanting the device in the host.

[0015] Further encompassed by the invention is a method of measuring glucose in a biological fluid including the steps of providing a host and a implantable device described above, which includes a sensor head capable of accurate continuous glucose sensing; and implanting the device in the host.

[0016] The sensor head, membrane architectures, devices, and methods of the present invention allow for the collection of continuous information regarding desired analyte levels (*e.g.* glucose). Such continuous information enables the determination of trends in glucose levels, which can be extremely important in the management of diabetic patients.

Definitions

[0017] In order to facilitate an understanding of the present invention, a number of terms are defined below.

[0018] The term "sensor head," as used herein, is a broad term and is used in its ordinary sense, including, without limitation, the region of a monitoring device responsible for the detection of a particular analyte. The sensor head generally comprises a non-conductive body, a working electrode (anode), a reference electrode and a counter electrode (cathode) passing through and secured within the body forming an electrochemically reactive surface at one location on the body and an electronic connective means at another location on the body, and a multi-region membrane affixed to the body and covering the electrochemically reactive surface. The counter electrode has a greater electrochemically reactive surface area than the working electrode. During general operation of the sensor a biological sample (*e.g.*, blood or interstitial fluid) or a portion thereof contacts (directly or after passage through one or more membranes or domains) an enzyme (*e.g.*, glucose oxidase); the reaction of the biological sample (or portion thereof) results in the formation of reaction products that allow a determination of the analyte (*e.g.* glucose) level in the biological sample. In preferred embodiments of the present invention, the multi-region membrane further comprises an enzyme domain, and an electrolyte phase (*i.e.*, a free-flowing liquid phase comprising an electrolyte-containing fluid described further below).

[0019] The term "analyte," as used herein, is a broad term and is used in its ordinary sense, including, without limitation, to a substance or chemical constituent in a biological fluid (*e.g.*, blood, interstitial fluid, cerebral spinal fluid, lymph fluid or urine) that can be analyzed. A preferred analyte for measurement by the sensor heads, devices, and methods of the present invention is glucose.

[0020] The term “electrochemically reactive surface,” as used herein, is a broad term and is used in its ordinary sense, including, without limitation, the surface of an electrode where an electrochemical reaction takes place. In the case of the working electrode, the hydrogen peroxide produced by the enzyme catalyzed reaction of the analyte being detected reacts creating a measurable electronic current (*e.g.* detection of glucose analyte utilizing glucose oxidase produces H_2O_2 peroxide as a by product, H_2O_2 reacts with the surface of the working electrode producing two protons (2H^+), two electrons (2e^-) and one molecule of oxygen (O_2) which produces the electronic current being detected). In the case of the counter electrode, a reducible species, *e.g.* O_2 is reduced at the electrode surface in order to balance the current being generated by the working electrode.

[0021] The term “electronic connection,” as used herein, is a broad term and is used in its ordinary sense, including, without limitation, any electronic connection known to those in the art that may be utilized to interface the sensor head electrodes with the electronic circuitry of a device such as mechanical (*e.g.*, pin and socket) or soldered.

[0022] The term “domain,” as used herein, is a broad term and is used in its ordinary sense, including, without limitation, regions of the membrane of the present invention that may be layers, uniform or non-uniform gradients (*e.g.* anisotropic) or provided as portions of the membrane.

[0023] The term “multi-region membrane,” as used herein, is a broad term and is used in its ordinary sense, including, without limitation, a permeable membrane that may be comprised of two or more domains and constructed of biomaterials of a few microns thickness or more which are permeable to oxygen and may or may not be permeable to glucose. One of the membranes may be placed over the sensor body to keep host cells (*e.g.*, macrophages) from gaining proximity to, and thereby damaging, the enzyme

membrane or forming a barrier cell layer and interfering with the transport of analyte across the tissue-device interface.

[0024] The phrase "distant from," as used herein, is a broad term and is used in its ordinary sense, including, without limitation, the spatial relationship between various elements in comparison to a particular point of reference. For example, some embodiments of a biological fluid measuring device comprise a multi-region membrane that may be comprised of a number of domains. If the electrodes of the sensor head are deemed to be the point of reference, and one of the multi-region membrane domains is positioned farther from the electrodes, than that domain is distant from the electrodes.

[0025] The term "oxygen antenna domain," as used herein, is a broad term and is used in its ordinary sense, including, without limitation, a domain composed of a material that has higher oxygen solubility than aqueous media so that it concentrates oxygen from the biological fluid surrounding the biointerface membrane. The domain can then act as an oxygen reservoir during times of minimal oxygen need and has the capacity to provide on demand a higher oxygen gradient to facilitate oxygen transport across the membrane. This enhances function in the enzyme reaction domain and at the counter electrode surface when glucose conversion to hydrogen peroxide in the enzyme domain consumes oxygen from the surrounding domains. Thus, this ability of the oxygen antenna domain to apply a higher flux of oxygen to critical domains when needed improves overall sensor function.

[0026] The term "solid portions," as used herein, is a broad term and is used in its ordinary sense, including, without limitation, a material having a structure that may or may not have an open-cell configuration but in either case prohibits whole cells from traveling through or residing within the material.

[0027] The term "substantial number," as used herein, is a broad term and is used in its ordinary sense, including, without limitation, to refer to the number of cavities or solid

portions having a particular size within a domain in which greater than 50 percent of all cavities or solid portions are of the specified size, preferably greater than 75 percent and most preferably greater than 90 percent of the cavities or solid portions have the specified size.

5 [0028] The term "co-continuous," as used herein, is a broad term and is used in its ordinary sense, including, without limitation, a solid portion wherein an unbroken curved line in three dimensions exists between any two points of the solid portion.

[0029] The term "host," as used herein, is a broad term and is used in its ordinary sense, including, without limitation, both humans and animals.

10 [0030] The term "accurately," as used herein, is a broad term and is used in its ordinary sense, including, without limitation, to refer to, for example, 90% of measured glucose values are within the "A" and "B" region of a standard Clarke error grid when the sensor measurements are compared to a standard reference measurement. It is understood that like any analytical device, calibration, calibration validation, and recalibration are
15 required for the most accurate operation of the device.

[0031] The phrase "continuous glucose sensing," as used herein, is a broad term and is used in its ordinary sense, including, without limitation, the period in which monitoring of plasma glucose concentration is continuously performed, for example, about every 10 minutes.

20 **BRIEF DESCRIPTION OF THE DRAWINGS**

[0032] Fig. 1 is an illustration of thermodynamically favored reactions at the working electrode and counter electrode at the desired voltage potentials.

[0033] Fig. 2A depicts a cross-sectional exploded view of a sensor head of the present invention wherein the multi-region membrane comprises three regions.

[0034] Fig. 2B depicts a cross-sectional exploded view of a sensor head of the present invention wherein a portion of the second membrane region does not cover the working electrode.

[0035] Fig. 2C depicts a cross-sectional exploded view of a sensor head of the present invention which includes two distinct regions, wherein the region adjacent the electrochemically reactive surfaces includes a portion positioned over the counter electrode which corresponds to a silicone domain.

[0036] Fig. 2D depicts a cross-sectional exploded view of a sensor head of the present invention wherein an active enzyme of the immobilized enzyme domain is positioned only over the working electrode.

[0037] Fig. 2E depicts a cross-sectional exploded view of a sensor head of the present invention wherein the enzyme positioned over the counter electrode has been inactivated.

[0038] Fig. 2F depicts a cross-sectional exploded view of a sensor head of the present invention wherein the membrane region containing immobilized enzyme is positioned only over the working electrode.

[0039] Fig. 3 is an illustration of an implantable glucose sensor's ability to measure glucose concentration during an infusion study in a canine when the counter electrode voltage drops to the electronic circuitry limit at approximately 0.75 hours wherein the sensor current output reaches 2.50 nA.

[0040] Fig. 4 is an illustration of an implantable glucose sensor's ability to measure glucose concentration during an infusion study in a canine when the counter electrode voltage drops to the electronic circuitry limit after 0.5 hours wherein the sensor current output reaches 0.50 nA.

[0041] Fig. 5 is an illustration of an implantable glucose sensor's ability to measure glucose concentration during an infusion study in a canine when the counter electrode voltage is maintained above the electronic circuitry limit.

[0042] Fig. 6A shows a schematic representation of a cylindrical analyte-measuring device including a sensor head according to the present invention.

[0043] Fig. 6B is an exploded view of the sensor head of the device shown in Fig. 6A.

[0044] Fig. 7 is a graphical representation of the function of a device of the present invention utilizing the multi-region membrane architecture of Fig. 2B *in vitro* at 400 mg/dL glucose.

[0045] Fig. 8 depicts a cross-sectional exploded view of the electrode and membrane regions of a prior sensor device where the electrochemical reactive surface of the counter electrode is substantially equal to the surface area of the working electrode.

[0046] Fig. 9 Graphical representation of the counter electrode voltage as a function of oxygen concentration at 400 mg/dL glucose for sensor devices including the membrane shown in Fig. 8.

DETAILED DESCRIPTION OF THE INVENTION

[0047] In a preferred embodiment, the sensor heads, devices, and methods of the present invention may be used to determine the level of glucose or other analytes in a host. The level of glucose is a particularly important measurement for individuals having diabetes in that effective treatment depends on the accuracy of this measurement.

[0048] The present invention increases the effectiveness of counter electrode function by a method that does not depend on increasing the local concentration of oxygen. In a preferred embodiment, the counter electrode has an electrochemical reactive surface area greater than twice the surface area of the working electrode thereby substantially

increasing the electrode's ability to utilize oxygen as a substrate. Further enhancement of the counter electrode's activity may be achieved if the electrode were made of gold. In a second preferred embodiment, the counter electrode has a textured surface, with surface topography that increases the surface area of the electrode while the diameter of the electrode remains constant. In a third preferred embodiment, the proximity of the glucose oxidase enzyme to the counter electrode may be decreased. Since the enzyme depletes oxygen locally, the counter electrode would best be situated at a location distant from the enzyme. This could be achieved by depleting the enzyme from or inactivating the enzyme located in the region near and over the counter electrode by methods known to those skilled in the art such as laser ablation, or chemical ablation. Alternatively, the membrane could be covered with an additional domain where glucose is selectively blocked from the area over the counter electrode.

[0049] In particular, the present invention reduces the potential for electrode poisoning by positioning all electrodes underneath a multi-region membrane so that there is control of the species reaching the electrode surfaces. These membranes allow passage of dissolved oxygen to support the counter electrode reactions at reasonable negative potentials while rejecting larger molecules which when reduced would coat the surface of the counter electrode eventually leading to cascade failure. The positioning of the counter electrode underneath the membrane assures that all currents are passing through the same conductive media, thereby reducing voltage losses due to membrane or solution resistance. In addition, the counter electrode will be able to collect enough species for the balancing current while minimizing the need to move towards negative potential extremes.

[0050] Although the description that follows is primarily directed at glucose monitoring sensor heads, devices and methods for their use, the sensor heads, devices and methods of the present invention are not limited to glucose measurement. Rather, the

devices and methods may be applied to detect and quantitate other analytes present in biological fluids (including, but not limited to, amino acids and lactate), especially those analytes that are substrates for oxidase enzymes [*see, e.g.*, U.S. Patent No. 4,703,756 to Gough *et al.*, hereby incorporated by reference].

5 **I. Nature of the Foreign Body Capsule**

[0051] Devices and probes that are implanted into subcutaneous tissue will almost always elicit a foreign body capsule (FBC) as part of the body's response to the introduction of a foreign material. Therefore, implantation of a glucose sensor results in an acute inflammatory reaction followed by building of fibrotic tissue. Ultimately, a mature
10 FBC comprising primarily a vascular fibrous tissue forms around the device (Shanker and Greisler, *Inflammation and Biomaterials* in Greco RS, ed. "Implantation Biology: The Host Response and Biomedical Devices," pp 68-80, CRC Press (1994)).

[0052] In general, the formation of a FBC has precluded the collection of reliable, continuous information, reportedly because of poor vascularization (Updike, S.J. *et al.*,
15 "Principles of Long-term Fully Implanted Sensors with Emphasis on Radiotelemetric Monitoring of Blood Glucose from inside a Subcutaneous Foreign Body Capsule (FBC)" in "Biosensors and the Body," D.M. Fraser, ed., 1997, pp 117-38, John Wiley and Sons, New York). Thus, those skilled in the art have previously attempted to minimize FBC formation by, for example, using a short-lived needle geometry or sensor coatings to minimize the
20 foreign body.

[0053] In contrast to the prior art, the teachings of the present invention recognize that FBC formation is the dominant event surrounding long-term implantation of any sensor and must be managed to support, rather than hinder or block, sensor performance. It has been observed that during the early periods following implantation of an analyte-
25 sensing device, particularly a glucose-sensing device, that glucose sensors function well.

However, after a few days to two or more weeks of implantation, these devices lose their function.

[0054] We have observed that this lack of sensor function is most likely due to cells (barrier cells) that associate with the outer surface of the device and physically block the transport of glucose into the device (*i.e.* form a barrier cell layer). Increased vascularization would not be expected to overcome this blockage. The present invention contemplates the use of particular biointerface membrane architectures that interfere with barrier cell layer formation on the membrane's surface. The present invention also contemplates the use of these membranes with a variety of implantable devices (*e.g.* analyte measuring devices particularly glucose measuring devices).

II. The Sensor Head

[0055] In one embodiment of the sensor head of the invention, the body is made of a non-conductive material such as ceramic, glass, or polymer.

[0056] In a preferred embodiment, the sensor head interface region may include several different layers and/or membranes that cover and protect the electrodes of an implantable analyte-measuring device. The characteristics of these layers and/or membranes are now discussed in more detail. The layers and/or membranes prevent direct contact of the biological fluid sample with the electrodes, while permitting selected substances (*e.g.*, analytes) of the fluid to pass therethrough for reaction in an enzyme rich domain with subsequent electrochemical reaction of formed products at the electrodes.

[0057] It is well known in the art that electrode surfaces exposed to a wide range of biological molecules may suffer poisoning of catalytic activity and possible corrosion that could result in failure. However, utilizing the unique multi-region membrane architectures of the present invention, the active electrochemical surfaces of the sensor electrodes are preserved, retaining activity for extended periods of time *in vivo*. By limiting access to the

electrochemically reactive surface of the electrodes to a small number of molecular species such as, for example, molecules having a molecular weight of about 34 Daltons (the molecular weight of peroxide) or less, only a small subset of the many molecular species present in biological fluids are permitted to contact the sensor. Use of such membranes has
5 enabled sustained function of devices for over one year *in vivo*.

A. Multi-Region Membrane

[0058] The multi-region membrane is constructed of two or more regions. The multi-region membrane may be provided in a number of different architectures. In one architecture, the multi-region membrane includes a first region distant from the
10 electrochemically reactive surfaces, a second region less distant from the electrochemically reactive surfaces and a third region adjacent to the electrochemically reactive surfaces. The first region includes a cell disruptive domain distant from the electrochemically reactive surfaces and a cell impermeable domain less distant from the electrochemically reactive surfaces. The second region is a glucose exclusion domain and the third region includes a
15 resistance domain distant from the electrochemically reactive surfaces, an immobilized enzyme domain less distant from the electrochemically reactive surfaces, an interference domain less distant from the electrochemically reactive surfaces than the immobilized enzyme domain and a hydrogel domain adjacent to the electrochemically reactive surfaces.

[0059] In another architecture, the multi-region membrane includes a first region
20 distant from the electrochemically reactive surfaces and a further region less distant from the electrochemically reactive surfaces. The first region includes a cell disruptive domain and a cell impermeable domain as described above. The “further region” includes a resistance domain, immobilized enzyme domain, interference domain, and hydrogel domain and serves as the equivalent of the “third region” described above. In certain

embodiments of the sensor head, the multi-region membrane further includes an oxygen antenna domain. Each of these domains will now be described in further detail.

i. Cell Disruptive Domain

[0060] The domain of the multi-region membrane positioned most distal to the electrochemically reactive surfaces corresponds to the cell disruptive domain. This domain includes a material that supports tissue in-growth and may be vascularized. The cell disruptive domain prevents formation of the barrier cell layer on the surface of the membrane, which as described above, blocks the transport of glucose into the sensor device. A useful cell disruptive domain is described in a U.S. application entitled "Membrane for use with Implantable Devices" Application No. 09/916,386 filed July 27, 2001, the contents of which is hereby incorporated by reference in its entirety. The cell disruptive domain may be composed of an open-cell configuration having cavities and solid portions. Cells may enter into the cavities. However, they can not travel through or wholly exist within the solid portions. The cavities allow most substances to pass through, including, *e.g.*, macrophages.

[0061] The open-cell configuration yields a co-continuous solid domain that contains greater than one cavity in three dimensions substantially throughout the entirety of the membrane. In addition, the cavities and cavity interconnections may be formed in layers having different cavity dimensions.

[0062] A linear line can be used to define a dimension across a cavity or solid portion the length of which is the distance between two points lying at the interface of the cavity and solid portion. In this way, a substantial number of the cavities are not less than 20 microns in the shortest dimension and not more than 1000 microns in the longest dimension. Preferably, a substantial number of the cavities are not less than 25 microns in the shortest dimension and not more than 500 microns in the longest dimension.

[0063] Furthermore, the solid portion has not less than 5 microns in a substantial number of the shortest dimensions and not more than 2000 microns in a substantial number of the longest dimensions. Preferably, the solid portion is not less than 10 microns in a substantial number of the shortest dimensions and not more than 1000 microns in a substantial number of the longest dimensions and most preferably, not less than 10 microns in a substantial number of the shortest dimensions and not more than 400 microns in a substantial number of the longest dimensions.

[0064] The solid portion may be made of polytetrafluoroethylene or polyethylene-co-tetrafluoroethylene, for example. Preferably, the solid portion includes polyurethanes or block copolymers and, most preferably, includes silicone.

[0065] When non-woven fibers are utilized as the solid portion of the present invention, the non-woven fibers may be greater than 5 microns in the shortest dimension. Preferably, the non-woven fibers are about 10 microns in the shortest dimension and most preferably, the non-woven fibers are greater than or equal to 10 microns in the shortest dimension.

[0066] The non-woven fibers may be constructed of polypropylene (PP), polyvinylchloride (PVC), polyvinylidene fluoride (PVDF), polybutylene terephthalate (PBT), polymethylmethacrylate (PMMA), polyether ether ketone (PEEK), polyurethanes, cellulosic polymers, polysulfones, and block copolymers thereof including, for example, di-block, tri-block, alternating, random and graft copolymers (block copolymers are discussed in U.S. Patent Nos. 4,803,243 and 4,686,044, hereby incorporated by reference). Preferably, the non-woven fibers are comprised of polyolefins or polyester or polycarbonates or polytetrafluoroethylene.

[0067] A subset of the cell disruptive domain is the oxygen antenna domain. This domain can act as an oxygen reservoir during times of minimal oxygen need and has the

capacity to provide on demand a higher oxygen gradient to facilitate oxygen transport across the membrane. This domain may be composed of a material such as silicone, that has higher oxygen solubility than aqueous media so that it concentrates oxygen from the biological fluid surrounding the biointerface membrane. This enhances function in the enzyme reaction domain and at the counter electrode surface when glucose conversion to hydrogen peroxide in the enzyme domain consumes oxygen from the surrounding domains. Thus, this ability of the oxygen antenna domain to apply a higher flux of oxygen to critical domains when needed improves overall sensor function. Preferably, this domain is composed of silicone and has a thickness of about 100 microns.

10 [0068] The thickness of the cell disruptive domain is usually not less than about 20 microns and not more than about 2000 microns.

ii. Cell Impermeable Domain

[0069] The cell impermeable of the first region is positioned less distal to the electrochemically reactive surfaces than the cell disruptive domain of the same region. This domain is impermeable to host cells, such as macrophages. Cell impermeable domains are described in U.S. Patent No. 6,001,067, herein incorporated by reference, and in copending, commonly owned U.S. application entitled "Membrane for use with Implantable Device", Serial No. 09/916,386, filed on July 27, 2001. The inflammatory response that initiates and sustains a FBC is associated with disadvantages in the practice of sensing analytes. Inflammation is associated with invasion of inflammatory response cells (e.g. macrophages) which have the ability to overgrow at the interface and form barrier cell layers, which may block transport of glucose across the biointerface membrane. These inflammatory cells may also biodegrade many artificial biomaterials (some of which were, until recently, considered non-biodegradable). When activated by a foreign body, tissue macrophages degranulate, releasing from their cytoplasmic myeloperoxidase system

hypochlorite (bleach) and other oxidative species. Hypochlorite and other oxidative species are known to break down a variety of polymers, including ether-based polyurethanes, by a phenomenon referred to as environmental stress cracking. Alternatively, polycarbonate based polyurethanes are believed to be resistant to environmental stress cracking and have been termed bio-durable. In addition, because hypochlorite and other oxidizing species are short-lived chemical species *in vivo*, biodegradation will not occur if macrophages are kept a sufficient distance from the enzyme active membrane.

[0070] The present invention contemplates the use of cell impermeable biomaterials of a few microns thickness or more (*i.e.*, a cell impermeable domain) in most of its membrane architectures. This domain of the biointerface membrane is permeable to oxygen and may or may not be permeable to glucose and is constructed of bio-durable materials (*e.g.* for period of several years *in vivo*) that are impermeable by host cells (*e.g.* macrophages) such as for example polymer blends of polycarbonate based polyurethane and PVP.

[0071] The thickness of the cell impermeable domain is not less than about 10 microns and not more than about 100 microns.

iii. Glucose Exclusion Domain

[0072] The glucose exclusion domain includes a thin, hydrophobic membrane that is non-swellable and blocks diffusion of glucose while being permeable to oxygen. The glucose exclusion domain serves to allow analytes and other substances that are to be measured or utilized by the sensor to pass through, while preventing passage of other substances. Preferably, the glucose exclusion domain is constructed of a material such as, for example, silicone.

[0073] The glucose exclusion domain has a preferred thickness not less than about 130 microns, more preferably not less than about 5 and not more than about 75 microns and most preferably not less than 15 microns and not more than about 50 microns.

iv. Resistance Domain

5 [0074] In one embodiment of the sensor head the “third region” or “further region” of the multi-region membrane includes a resistance domain. When present, the resistance domain is located more distal to the electrochemically reactive surfaces relative to other domains in this region. As described in further detail below, the resistance domain controls the flux of oxygen and glucose to the underlying enzyme domain. There is a molar excess
10 of glucose relative to the amount of oxygen in samples of blood. Indeed, for every free oxygen molecule in extracellular fluid, there are typically more than 100 glucose molecules present [Updike *et al.*, *Diabetes Care* 5:207-21(1982)]. However, an immobilized enzyme-based sensor using oxygen (O_2) as cofactor must be supplied with oxygen in non-rate-limiting excess in order to respond linearly to changes in glucose concentration, while not
15 responding to changes in oxygen tension. More specifically, when a glucose-monitoring reaction is oxygen-limited, linearity is not achieved above minimal concentrations of glucose. Without a semipermeable membrane over the enzyme domain, linear response to glucose levels can be obtained only up to about 40 mg/dL; however, in a clinical setting, linear response to glucose levels are desirable up to at least about 500 mg/dL.

20 [0075] The resistance domain includes a semipermeable membrane that controls the flux of oxygen and glucose to the underlying enzyme domain (*i.e.*, limits the flux of glucose), rendering the necessary supply of oxygen in non-rate-limiting excess. As a result, the upper limit of linearity of glucose measurement is extended to a much higher value than that which could be achieved without the resistance domain. The devices of the present
25 invention contemplate resistance domains including polymer membranes with oxygen-to-

glucose permeability ratios of approximately 200:1; as a result, one-dimensional reactant diffusion is adequate to provide excess oxygen at all reasonable glucose and oxygen concentrations found in the subcutaneous matrix [Rhodes *et al.*, *Anal. Chem.*, 66:1520-1529 (1994)].

5 [0076] In preferred embodiments, the resistance domain is constructed of a polyurethane urea/polyurethane-block-polyethylene glycol blend and has a thickness of not more than about 45 microns, more preferably not less than about 15 microns, and not more than about 40 microns and, most preferably, not less than about 20 microns, and not more than about 35 microns.

10 v. Immobilized Enzyme Domain

[0077] When the resistance domain is combined with the cell-impermeable domain, it is the immobilized enzyme domain which corresponds to the outermost domain of the "third region" or "further region," *i.e.* it is located more distal to the electrochemically reactive surfaces as compared to the other domains in this region. In one embodiment, the enzyme domain includes glucose oxidase. In addition to glucose oxidase, the present invention contemplates the use of a domain impregnated with other oxidases, *e.g.*, galactose oxidase or uricase. For an enzyme-based electrochemical glucose sensor to perform well, the sensor's response must neither be limited by enzyme activity nor cofactor concentration. Because enzymes, including glucose oxidase, are subject to deactivation as a function of ambient conditions, this behavior needs to be accounted for in constructing sensors for long-term use.

[0078] Preferably, the domain is constructed of aqueous dispersions of colloidal polyurethane polymers including the enzyme. Preferably, the coating has a thickness of not less than about 2.5 microns and not more than about 12.5 microns, preferably about 6.0
25 microns.

vi. Interference Domain

[0079] The interference domain in the “third region” or “further region” is located less distant from the electrochemically reactive surfaces than the immobilized enzyme domain in this same region. It includes a thin membrane that can limit diffusion of
5 molecular weight species greater than 34 kD. The interference domain serves to allow analytes and other substances that are to be measured by the electrodes to pass through, while preventing passage of other substances, including potentially interfering substances. The interference domain is preferably constructed of a polyurethane.

[0080] The interference domain has a preferred thickness of not more than about 5
10 microns, more preferably not less than about 0.1 microns, and not more than about 5 microns and, most preferably, not less than about 0.5 microns, and not more than about 3 microns.

vii. Hydrogel Domain

[0081] The hydrogel domain is located adjacent to the electrochemically reactive
15 surfaces. To ensure electrochemical reaction, the hydrogel domain includes a semipermeable coating that maintains hydrophilicity at the electrode region of the sensor interface. The hydrogel domain enhances the stability of the interference domain of the present invention by protecting and supporting the membrane that makes up the interference domain. Furthermore, the hydrogel domain assists in stabilizing operation of
20 the device by overcoming electrode start-up problems and drifting problems caused by inadequate electrolyte. The buffered electrolyte solution contained in the hydrogel domain also protects against pH-mediated damage that may result from the formation of a large pH gradient between the hydrophobic interference domain and the electrode (or electrodes) due to the electrochemical activity of the electrode(s).

[0082] Preferably, the hydrogel domain includes a flexible, water-swella-
substantially solid gel-like film having a "dry film" thickness of not less than about 2.5
microns and not more than about 12.5 microns; preferably, the thickness is about 6.0
microns. "Dry film" thickness refers to the thickness of a cured film cast from a coating
5 formulation onto the surface of the membrane by standard coating techniques.

[0083] Suitable hydrogel domains are formed of a curable copolymer of a urethane
polymer and a hydrophilic film-forming polymer. Particularly preferred coatings are
formed of a polyurethane polymer having anionic carboxylate functional groups and non-
ionic hydrophilic polyether segments, which is crosslinked in the present of
10 polyvinylpyrrolidone and cured at a moderate temperature of about 50°C.

B. Electrolyte Phase

[0084] The electrolyte phase is a free-fluid phase including a solution containing at
least one compound, usually a soluble chloride salt, that conducts electric current. The
electrolyte phase flows over the electrodes and is in contact with the hydrogel domain. The
15 devices of the present invention contemplate the use of any suitable electrolyte solution,
including standard, commercially available solutions.

[0085] Generally speaking, the electrolyte phase should have the same or less
osmotic pressure than the sample being analyzed. In preferred embodiments of the present
invention, the electrolyte phase includes normal saline.

20 C. Membrane Architectures

[0086] Prior art teaches that an enzyme containing membrane that resides above an
amperometric electrochemical sensor can possess the same architecture throughout the
electrode surfaces. However, the function of converting glucose into hydrogen peroxide by
glucose oxidase may only be necessary above the working electrode. In fact, it may be
25 beneficial to limit the conversion of glucose into hydrogen peroxide above the counter

electrode. Therefore, the present invention contemplates a number of membrane architectures that include a multi-region membrane wherein the regions include at least one domain.

[0087] Referring now to Fig. 2A, which shows one desired embodiment of the general architecture of a three region membrane, first region 33 is permeable to oxygen and glucose and includes a cell disruptive domain distant from the electrodes and a cell impermeable domain less distant from the electrodes. The second region 31 is permeable to oxygen and includes a glucose exclusion domain and region three 32 includes a resistance domain, distant from the electrochemically reactive surfaces, an immobilized enzyme domain less distant from the electrochemically reactive surfaces, an interference domain less distant from the electrochemically reactive surfaces than the immobilized enzyme and a hydrogel domain adjacent to the electrochemically reactive surfaces. The multi-region membrane is positioned over the sensor interface 30 of the non-conductive body 10, covering the working electrode 21, the reference electrode 20, and the counter electrode 22. The electrodes are brazed to the sensor head and back filled with epoxy 28.

[0088] In Fig. 2B, the glucose exclusion domain has been positioned over the electrochemically reactive surfaces such that it does not cover the working electrode 21. To illustrate this, a hole 35 has been created in the second region 31 and positioned directly above the working electrode 21. In this way, glucose is blocked from entering the underlying enzyme membrane above the counter electrode 22 and O₂ is conserved above the counter electrode because it is not being consumed by the glucose oxidation reaction. The glucose-blocking domain is made of a material that allows sufficient O₂ to pass to the counter electrode. The glucose-blocking domain may be made of a variety of materials such as silicone or silicone containing copolymers. Preferably, the glucose-blocking domain is made of silicone.

[0089] In Fig. 2C, the multi-region membrane is shown as being constructed of two regions: a first region 33 which includes a cell disruptive domain and a cell impermeable domain; and a further region 32. Region 32 is defined herein as including an enzyme-immobilized domain, interference domain, and hydrogel domain and may also include a resistance domain. Region 32 is referred to as the “third region” in embodiments where the multi-region membrane includes three regions. In the embodiment shown, a silicone domain plug 36 positioned over the counter electrode 22 in order to eliminate the consumption of O₂ above the counter electrode by the oxidation of glucose with glucose oxidase. The enzyme immobilized domain can be fabricated as previously described, then a hole punched into the domain. The silicone domain plug 36 may be cut to fit the hole, and then adhered into place, for example, with silicone adhesive (*e.g.*, MED-1511, NuSil, Carpinteria, CA).

[0090] In Fig. 2D, the immobilized enzyme domain of the multi-region membrane can be fabricated such that active enzyme 37 is positioned only above the working electrode 21. In this architecture, the immobilized enzyme domain may be prepared so that the glucose oxidase only exists above the working electrode 21. During the preparation of the multi-region membrane, the immobilized enzyme domain coating solution can be applied as a circular region similar to the diameter of the working electrode. This fabrication can be accomplished in a variety of ways such as screen-printing or pad printing. Preferably, the enzyme domain is pad printed during the enzyme membrane fabrication with equipment as available from Pad Print Machinery of Vermont (Manchester, VT). These architectures eliminate the consumption of O₂ above the counter electrode 22 by the oxidation of glucose with glucose oxidase.

[0091] In Fig. 2E, the immobilized enzyme of the multi-region membrane in region 32 may be deactivated 38 except for the area covering the working electrode 21. In some

of the previous membrane architectures, the glucose oxidase is distributed homogeneously throughout the immobilized enzyme domain. However, the active enzyme need only reside above the working electrode. Therefore, the enzyme may be deactivated 38 above the counter 22 and reference 20 electrodes by irradiation. A mask that covers the working
5 electrode 21, such as those used for photolithography can be placed above the membrane. In this way, exposure of the masked membrane to ultraviolet light deactivates the glucose oxidase in all regions except that covered by the mask.

[0092] Fig. 2F shows an architecture in which the third region 32 which includes immobilized enzyme only resides over the working electrode 21. In this architecture,
10 consumption of O₂ above the counter electrode 22 by the oxidation of glucose with glucose oxidase is eliminated.

D. The Electrode Assembly

[0093] The electrode assembly of this invention comprises a non-conductive body and three electrodes affixed within the body having electrochemically reactive surfaces at
15 one location on the body and an electronic connection means at another location on the body and may be used in the manner commonly employed in the making of amperometric measurements. A sample of the fluid being analyzed is placed in contact with a reference electrode, *e.g.*, silver/silver-chloride, a working electrode which is preferably formed of platinum, and a counter electrode which is preferably formed of gold or platinum. The
20 electrodes are connected to a galvanometer or polarographic instrument and the current is read or recorded upon application of the desired D.C. bias voltage between the electrodes.

[0094] The ability of the present device electrode assembly to accurately measure the concentration of substances such as glucose over a broad range of concentrations in fluids including undiluted whole blood samples enables the rapid and accurate

determination of the concentration of those substances. That information can be employed in the study and control of metabolic disorders including diabetes.

[0095] The present invention contemplates several structural architectures that effectively increase the electrochemically reactive surface of the counter electrode. In one embodiment, the diameter of wire used to create the counter electrode is at least twice the diameter of the working electrode. In this architecture, it is preferable that the electrochemically reactive surface of the counter electrode be not less than about 2 and not more than about 100 times the surface area of the working electrode. More preferably, the electrochemically reactive surface of the counter electrode is not less than about 2 and not more than about 50, not less than about 2 and not more than about 25 or not less than about 2 and not more than about 10 times the surface area of the working electrode. In another embodiment, the electrochemically reactive surface is larger than the wire connecting this surface to the sensor head. In this architecture, the electrode could have a cross-sectional view that resembles a "T." The present invention contemplates a variety of configurations of the electrode head that would provide a large reactive surface, while maintaining a relatively narrow connecting wire. Such configurations could be prepared by micromachining with techniques such as reactive ion etching, wet chemical etching and focused ion beam machining as available from Norsam Technologies (Santa Fe, NM).

[0096] In another embodiment, the diameter of the counter electrode is substantially similar to the working electrode. However, the surface of the counter electrode has been modified to increase the surface area such that it has at least twice the surface area of the working electrode. More specifically the counter electrodes surface may be textured, effectively increasing its surface area without significantly increasing its diameter. This may be accomplished by a variety of methods known to those skilled in the art including, such as acid etching. The electrochemically reactive surface may be provided in a variety

of shapes and sizes (*e.g.* round, triangular, square or free form) provided that it is at least twice the surface area of the working electrode.

[0097] In all of the architectures described, the electrodes are prepared from a 0.020" (0.51 mm) diameter wire having the desired modified reactive surface. The electrodes are secured inside the non-conductive body by brazing. The counter electrode is preferably made of gold or platinum.

III. Analyte Measuring Device

[0098] A preferred embodiment of an analyte-measuring device including a sensor head according to the present invention is shown in Fig. 6A. In this embodiment, a ceramic body 1 and ceramic head 10 houses the sensor electronics that include a circuit board 2, a microprocessor 3, a battery 4, and an antenna 5. Furthermore, the ceramic body 1 and head 10 possess a matching taper joint 6 that is sealed with epoxy. The electrodes are subsequently connected to the circuit board via a socket 8.

[0100] As indicated in detail in Fig. 6B, three electrodes protrude through the ceramic head 10, a platinum working electrode 21, a platinum counter electrode 22 and a silver/silver chloride reference electrode 20. Each of these is hermetically brazed 26 to the ceramic head 10 and further secured with epoxy 28. The sensing region 24 is covered with a multi-region membrane described above and the ceramic head 10 contains a groove 29 so that the membrane may be affixed into place with an o-ring.

IV. Experimental

[0101] The following examples serve to illustrate certain preferred embodiments and aspects of the present invention and are not to be construed as limiting the scope thereof.

[0102] In the preceding description and the experimental disclosure which follows, the following abbreviations apply: Eq and Eqs (equivalents); mEq (milliequivalents); M

(molar); mM (millimolar) μ M (micromolar); N (Normal); mol (moles); mmol (millimoles); μ mol (micromoles); nmol (nanomoles); g (grams); mg (milligrams); μ g (micrograms); Kg (kilograms); L (liters); mL (milliliters); dL (deciliters); μ L (microliters); cm (centimeters); mm (millimeters); μ m (micrometers); nm (nanometers); h and hr (hours); min. (minutes); s and sec. (seconds); °C (degrees Centigrade); Astor Wax (Titusville, PA); BASF Wyandotte Corporation (Parsippany, NJ); Data Sciences, Inc. (St. Paul, MN); DuPont (DuPont Co., Wilmington, DE); Exxon Chemical (Houston, TX); GAF Corporation (New York, NY); Markwell Medical (Racine, WI); Meadox Medical, Inc. (Oakland, NJ); Mobay (Mobay Corporation, Pittsburgh, PA); NuSil Technologies (Carpenteria, CA) Sandoz (East Hanover, NJ); and Union Carbide (Union Carbide Corporation; Chicago, IL).

Example 1

Preparation of the Multi-region Membrane

A. Preparation of the First Region

15 [0103] The cell disruptive domain may be an ePTFE filtration membrane and the cell impermeable domain may then be coated on this domain layer. The cell impermeable domain was prepared by placing approximately 706 gm of dimethylacetamide (DMAC) into a 3L stainless steel bowl to which a polycarbonateurethane solution (1325g, Chronoflex AR 25% solids in DMAC and 5100cp) and polyvinylpyrrolidone (125g, 20 Plasdone K-90D) are added. The bowl was then fitted to a planetary mixer with a paddle type blade and the contents were stirred for 1 hour at room temperature. This solution was then coated on the cell disruptive domain by knife edge drawn at a gap of 0.006" (152 microns) and dried at 60°C for 24 hours.

[0104] Alternatively, the polyurethane polyvinylpyrrolidone solution prepared 25 above can be coated onto a PET release liner using a knife over roll coating machine. This material is then dried at 305°F (152°C) for approximately 2 minutes. Next the ePTFE

membrane is immersed in 50:50 (w/v) mixture of THF/DMAC and then placed atop the coated polyurethane polyvinylpyrrolidone material. Light pressure atop the assembly intimately embeds the ePTFE into the polyurethane polyvinylpyrrolidone. The membrane is then dried at 60°C for 24 hours.

5 B. Preparation of the Glucose Exclusion Domain

[0105] An oxime cured silicone dispersion (NuSil Technologies, MED-6607) was cast onto a polypropylene sheet and cured at 40°C for three days.

 C. Preparation of the Third Region

[0106] The “third region” or “further region” includes a resistance domain, an immobilized enzyme domain, an interference domain and an hydrogel domain. The resistance domain was prepared by placing approximately 281 gm of dimethylacetamide into a 3 L stainless steel bowl to which a solution of polyetherurethaneurea (344 gm of Chronothane H, 29,750cp at 25% solids in DMAC). To this mixture was added another polyetherurethaneurea (312 gm, Chronothane 1020, 6275cp at 25% solids in DMAC). The bowl was fitted to a planetary mixer with a paddle type blade and the contents were stirred for 30 minutes at room temperature. The resistance domain coating solutions produced is coated onto a PET release liner (Douglas Hansen Co., Inc. Minneapolis, MN) using a knife over roll set at a 0.012” (305 microns) gap. This film is then dried at 305°F (152°C). The final film is approximately 0.0015” (38 microns) thick.

[0107] The immobilized enzyme domain was prepared by placing 304 g polyurethane latex (Bayhydrol 140AQ, Bayer, Pittsburgh, PA) into a 3 L stainless steel bowl to which 51 gm of pyrogen free water and 5.85 gm of glucose oxidase (Sigma type VII from *Aspergillus niger*) is added. The bowl was then fitted to a planetary mixer with a whisk type blade and the mixture was stirred for 15 minutes. Approximately 24 hr prior to coating a solution of glutaraldehyde (15.4 mL of a 2.5% solution in pyrogen free water)

and 14 mL of pyrogen free water was added to the mixture. The solution was mixed by inverting a capped glass bottle by hand for about 3 minutes at room temperature. This mixture was then coated over the resistance domain with a #10 Mayer rod and dried above room temperature preferably at about 50°C.

5 [0108] The interference domain was prepared by placing 187 gm of tetrahydrofuran into a 500 mL glass bottle to which 18.7 g aliphatic polyetherurethane (Tecoflex SG-85A, Thermedics Inc., Woburn, MA) was added. The bottle was placed onto a roller at approximately 3 rpm within an oven set at 37°C. The mixture was allowed to roll for 24 hr. This mixture was coated over the dried enzyme domain using a flexible knife and dried
10 above room temperature preferably at about 50°C.

[0109] The hydrogel domain was prepared by placing 388 g of polyurethane latex (Bayhydrol 123, Bayer, Pittsburgh, PA) in a 3 L stainless steel bowl to which 125 g of pyrogen free water and 12.5 g polyvinylpyrrolidone (Plasdone K-90D) was added. The bowl was then fitted to a planetary mixer with a paddle type blade and stirred for 1 hr at
15 room temperature. Within 30 minutes of coating approximately 13.1 mL of carbodiimide (UCARLNK) was added and the solution was mixed by inverting a capped polyethylene jar by hand for about 3 min at room temperature. This mixture was coated over the dried interference domain with a #10 Mayer rod and dried above room temperature preferably at about 50°C.

20 [0110] In order to affix this multi-region membrane to a sensor head, it is first placed into buffer for about 2 minutes. It is then stretched over the nonconductive body of sensor head and affixed into place with an o-ring.

Example 2

***In vitro* Evaluation of Sensor Devices**

25 [0111] This example describes experiments directed at sensor function of several sensor devices contemplated by the present invention.

[0112] *In vitro* testing of the sensor devices was accomplished in a manner similar to that previously described. [Gilligan *et al.*, Diabetes Care 17:882-887 (1994)]. Briefly, devices were powered on and placed into a polyethylene container containing phosphate buffer (450ml, pH 7.30) at 37°C. The container was placed onto a shaker (Lab Line Rotator, model 1314) set to speed 2. The sensors were allowed to equilibrate for at least 30 minutes and their output value recorded. After this time, a glucose solution (9.2 ml of 100mg/ml glucose in buffer) was added in order to raise the glucose concentration to 200 mg/dl within the container. The sensors were allowed to equilibrate for at least 30 minutes and their output value recorded. Again, a glucose solution (9.4 ml of 100mg/ml glucose in 10 buffer) was added in order to raise the glucose concentration to 400 mg/dl within the container. The sensors were allowed to equilibrate for at least 30 minutes and their output value recorded. In this way, the sensitivity of the sensor to glucose is given as the slope of sensor output versus glucose concentration. The container was then fitted with an O₂ meter (WTW, model Oxi-340) and a gas purge. A mixture of compressed air and nitrogen was 15 used to decrease the O₂ concentration. Sensor output was recorded at an ambient O₂ level, then sensor output was recorded for the following O₂ concentrations; 1mg/L, 0.85 to 0.75 mg/L, 0.65 to 0.55 mg/L and 0.40 to 0.30 mg/L. In this way, the function of the sensor could be compared to its function at ambient O₂.

[0113] Sensor devices like the one shown in Figs. 6A and 6B, which included 20 inventive sensor heads having a multi-region membrane with the architecture shown in Fig. 2B, were tested *in vitro*. Eight of these devices were fitted with membranes that possessed a 0.020" diameter hole, four with a 0.0015" (38 microns) thick polyurethane (Chronoflex AR, CardioTech International Inc.) and four with a 0.032" (813 microns) thick silicone (MED-1511, NuSil Technologies Inc.). The hole was positioned above the working 25 electrode and both membranes were secured to the device with an o-ring. Four control

devices were also tested which were fitted with a multi-region membrane which lacked region 31 shown in Fig. 2B.

[0114] As discussed above, for oxygen to be consumed in the sensing region 32 above the electrodes, glucose is required. By placing region 31 shown in Fig. 2B, which includes a glucose blocking domain, above all areas other than above the working electrode 21, oxygen consumption in areas other than working electrode areas is limited. In contrast, by eliminating region 31 in the control devices, less overall oxygen becomes available to electrode surfaces due to the increased availability of glucose.

[0115] The devices were activated, placed into a 500 ml-polyethylene container with sodium phosphate buffered solution (300 ml, pH 7.3) and allowed to equilibrate. Each device's baseline value was recorded. Then 12 ml of glucose solution (100 mg/ml in sodium phosphate buffer) was added to the container so that the total glucose concentration became 400 mg/dL. After this, the container was covered and fitted with an oxygen sensor and a source of nitrogen and compressed air. In this way, the oxygen concentration was controlled with a gas sparge. A glucose value was recorded for each device at decreasing oxygen concentrations from ambient to approximately 0.1 mg/L.

[0116] Fig. 7 graphically represents the formation of a device of the present invention utilizing the multi-region membrane architecture in Fig. 2B *in vitro*. The data is expressed in percent Device Function at 400 mg/dL glucose vs. oxygen concentration. The percent function of the device is simply the device output at any given oxygen concentration divided by that device's output at ambient oxygen. The results from Figure 7 indicate that inventive sensor devices containing the silicone membrane have better function at lower oxygen concentrations relative to both the control devices and the devices containing the polyurethane membrane. For example, at an oxygen concentration of about

0.5 mg/L, devices containing the silicone membrane are providing 100% output as compared to 80% output for the control devices.

Example 3

The effect of varying the size and material of the counter electrode on sensor response and accuracy

5 [0117] An *in vitro* testing procedure used in this example was similar to that described in Example 2. Six devices similar to the one shown in Fig. 6A and 6B were fitted with the multi-region membrane described herein. Two of these tested devices were comparative devices that possessed Pt counter electrodes having a 0.020" (508 microns) diameter; this diameter provided for an electrochemically reactive surface of the counter electrode which was substantially equal to the surface area of the working electrode, as schematically shown in Fig. 8. In FIG 8, the electrode-membrane region includes two distinct regions, the compositions and functions of which have already been described. Region 32 includes an immobilized enzyme. Region 33 includes a cell disruptive domain and a cell impermeable domain. The top ends of electrodes 21 (working), 20 (reference) and 22 (counter) are in contact with an electrolyte phase 30, a free-flowing phase. Two other tested devices possessed Pt counter electrodes having a 0.060" (1.5 mm) diameter. Finally, two additional devices possessed Au counter electrodes having a 0.060" (1.5 mm) diameter. The 0.060" (1.5 mm) diameter devices provided for an electrochemically reactive surface of the counter electrode which was approximately six times the surface area of the working electrode. Each of the devices including counter electrodes of 0.060" (1.5 mm) diameter include a multi-region membrane above the electrode region which is similar to that shown in Fig. 8.

[0118] The devices were activated, placed into a 500 ml-polyethylene container with sodium phosphate buffered solution (300 ml, pH 7.3) and allowed to equilibrate. Each device's baseline value was recorded. Then 12 ml of glucose solution (100 mg/ml in sodium phosphate buffer) was added to the container so that the total glucose concentration

became 400 mg/dL. After this, the container was covered and fitted with an oxygen sensor and a source of nitrogen and compressed air. In this way, the oxygen concentration was controlled with a gas sparge. A counter electrode voltage was recorded for each device at decreasing oxygen concentrations from ambient to approximately 0.1 mg/L.

5 [0119] Fig. 9 graphically presents the counter electrode voltage as a function of oxygen concentration and 400 mg/dL glucose. This figure demonstrates that both the large Pt and Au counter electrode devices do not begin to reach the circuitry limits at low oxygen concentrations. Therefore, increased performance and accuracy can be obtained from a counter electrode that has an electrochemical reactive surface greater than the surface area
10 of the working electrode.

[0120] The description and experimental materials presented above are intended to be illustrative of the present invention while not limiting the scope thereof. It will be apparent to those skilled in the art that variations and modifications can be made without departing from the spirit and scope of the present invention. All references cited herein are
15 hereby incorporated herein in their entireties by reference thereto.

WHAT IS CLAIMED IS:

1. A sensor head for use in an analyte measuring device comprising:
 - a) a non-conductive body;
 - b) a working electrode, a reference electrode and a counter electrode, wherein
5 said electrodes pass through said non-conductive body forming an electrochemically reactive surface at one location on said body and an electronic connection at another location on said body, further wherein said electrochemical reactive surface of said counter electrode is greater than the surface area of said working electrode; and
 - c) a multi-region membrane affixed over said non-conductive body and
10 covering said working electrode, reference electrode and counter electrode.
2. A sensor head for use in an implantable analyte measuring device comprising:
 - a) a non-conductive body;
 - b) a working electrode, a reference electrode and a counter electrode, wherein
said electrodes pass through said non-conductive body forming an electrochemically
15 reactive surface at one location on said body and an electronic connection at another location on said body, further wherein said electrochemical reactive surface of said counter electrode is greater than the surface area of said working electrode; and
 - c) a multi-region membrane affixed over said non-conductive body and
covering said working electrode, reference electrode and counter electrode.
- 20 3. A sensor head according to claim 1 wherein said multi-region membrane comprises an oxygen antenna domain.
4. A sensor head according to claim 2 wherein said multi-region membrane comprises an oxygen antenna domain.
5. A sensor head according to claim 2 wherein said multi-region membrane comprises
25 a first region distant from said electrochemically reactive surfaces, a second region less

distant from said electrochemically reactive surfaces and a third region adjacent to said electrochemically reactive surfaces.

6. A sensor head according to claim 5 wherein said first region comprises a cell disruptive domain distant from said electrochemically reactive surfaces and a cell impermeable domain less distant from said electrochemically reactive surfaces.

7. A sensor head according to claim 5 wherein said second region is a glucose exclusion domain.

8. A sensor head according to claim 5 wherein said third region comprises an immobilized enzyme domain distant from said electrochemically reactive surfaces, an interference domain less distant from said electrochemically reactive surfaces than said immobilized enzyme domain and a hydrogel domain adjacent to said electrochemically reactive surfaces.

9. A sensor head according to claim 8 wherein said third region further comprises a resistance domain more distant from said electrochemically reactive surfaces than said immobilized enzyme domain.

10. A sensor head according to claim 5 wherein said first region is permeable to oxygen and glucose.

11. A sensor head according to claim 5 wherein said second region is permeable to oxygen and interferes with glucose transport across said membrane, further wherein said second region does not cover the working electrode.

12. A sensor head according to claim 2 wherein said multi-region membrane comprises a first region distant from said electrochemically reactive surfaces and a further region adjacent to said electrochemically reactive surfaces.

13. A sensor head according to claim 12 wherein said first region comprises a cell disruptive domain distant from said electrochemically reactive surfaces and a cell impermeable domain less distant from said electrochemically reactive surfaces.
14. A sensor head according to claim 12 wherein said further region comprises an immobilized enzyme domain distant from said electrochemically reactive surfaces, an interference domain less distant from said electrochemically reactive surfaces than said immobilized enzyme domain and a hydrogel domain adjacent to said electrochemically reactive surfaces.
15. A sensor head according to claim 14 wherein said further region further comprises a resistance domain more distant from said electrochemically reactive surfaces than said immobilized enzyme domain.
16. A sensor head according to claim 12 wherein said further region comprises a portion positioned over only said counter electrode that reduces the consumption of oxygen above said counter electrode.
17. A sensor head according to claim 16 wherein said portion of said further region comprises silicone.
18. A sensor head according to claim 14 wherein an active enzyme of the immobilized enzyme domain of said further region is positioned only over the working electrode.
19. A sensor head according to claim 14 wherein an inactive enzyme of the immobilized enzyme domain of said further region is positioned only over the reference electrode and the counter electrode.
20. A sensor head according to claim 14 wherein said further region is positioned only over said working electrode.
21. A sensor head according to claim 2 wherein said non-conductive body is made of ceramic or glass.

22. A sensor head according to claim 2 wherein said non-conductive body is made of plastic or polymer.
23. A sensor head according to claim 2 wherein said working electrode is made of platinum.
- 5 24. A sensor head according to claim 2 wherein said counter electrode is made of platinum or gold.
25. A sensor head according to claim 2 wherein said electrochemically reactive surface of said counter electrode is greater than or equal to about two times the surface area of the working electrode and is less than or equal to about 100 times the surface area of the
10 working electrode.
26. A sensor head according to claim 2 wherein said electrode is greater than or equal to about two times the surface area of the working electrode and is less than or equal to about 50 times the surface area of the working electrode.
27. A sensor head according to claim 2 wherein said electrochemically reactive surface
15 of said counter electrode is greater than or equal to about two times the surface area of the working electrode and is less than or equal to about 25 times the surface area of the working electrode.
28. A sensor head according to claim 2 wherein said electrochemically reactive surface of said counter electrode is greater than or equal to about two times the surface area of the
20 working electrode and is less than or equal to about 10 times the surface area of the working electrode.
29. An implantable device for measuring an analyte in a biological fluid comprising at least one sensor head according to claim 2.
30. A method of monitoring glucose levels, comprising:
25 a) providing i) a host, and ii) an implantable device according to claim 29; and

- b) implanting said device in said host.
31. A method according to claim 30 wherein said implanting is subcutaneous.
32. A method of measuring glucose in a biological fluid, comprising;
- a) providing i) a host, and ii) an implantable device according to claim 29, said
- 5 sensor head being capable of accurate continuous glucose sensing; and
- b) implanting said device in said host.
33. A method according to claim 32, wherein said implanting is subcutaneous.

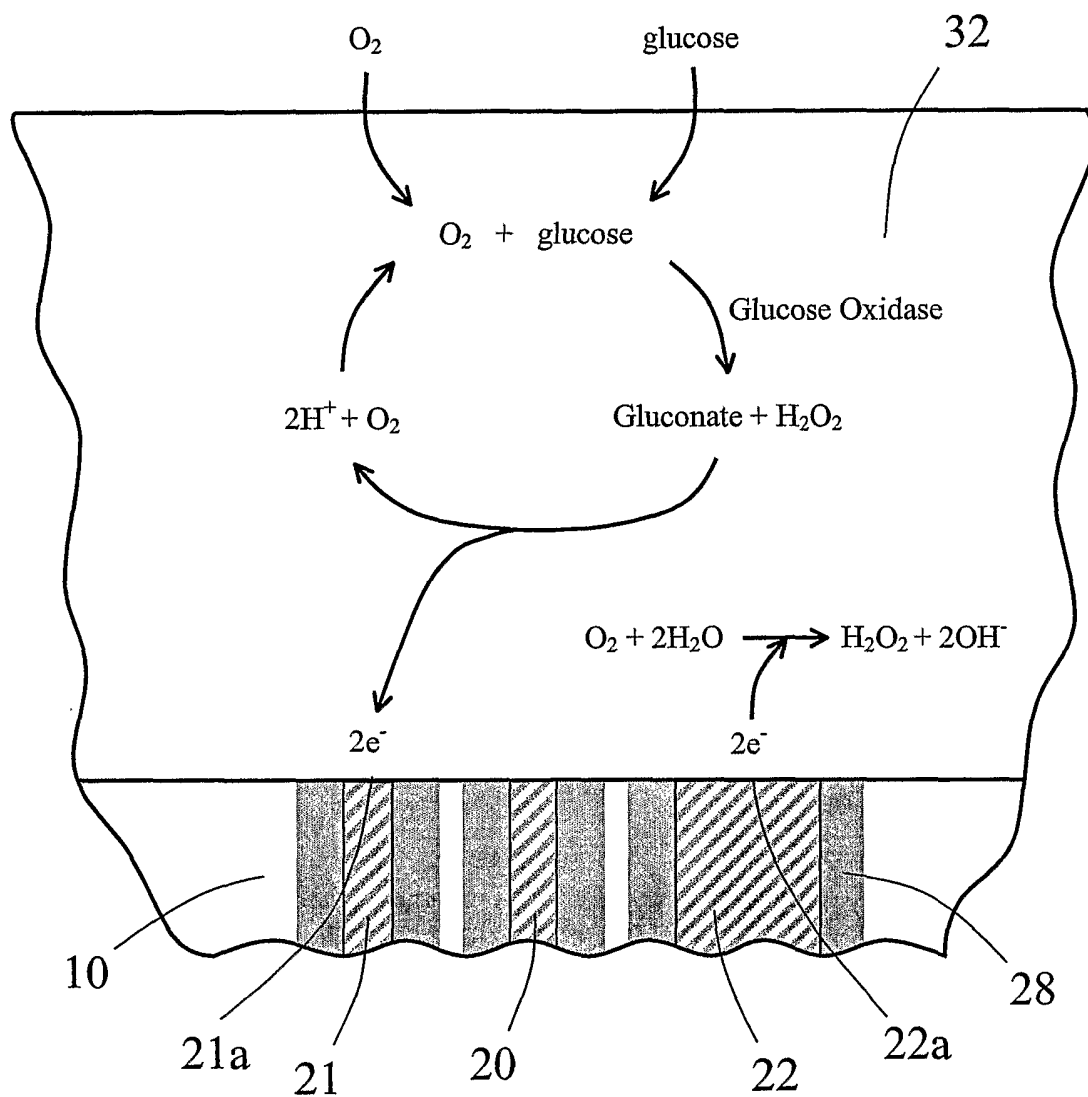

Figure 1

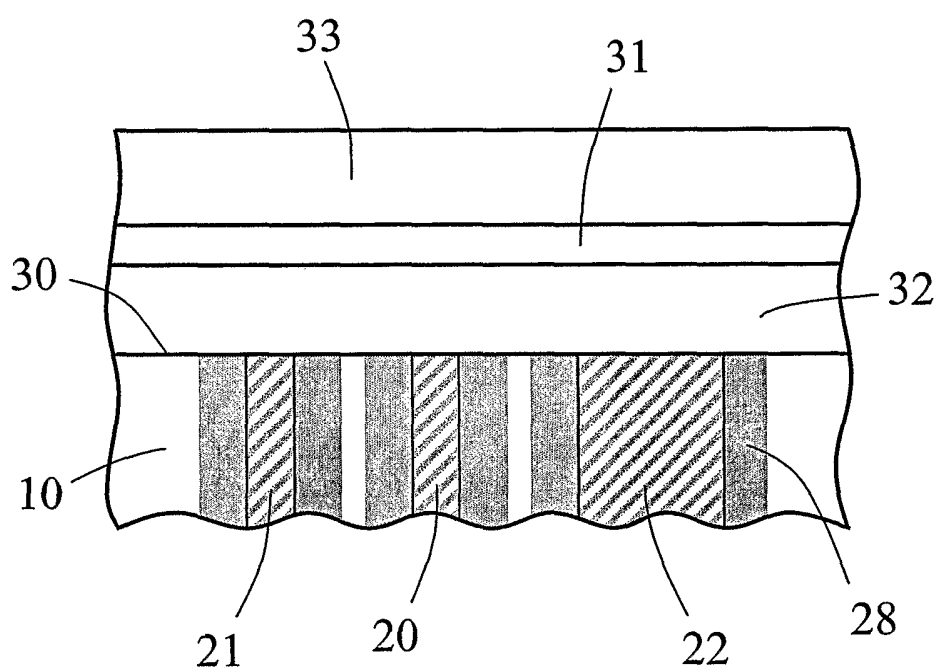

Figure 2A

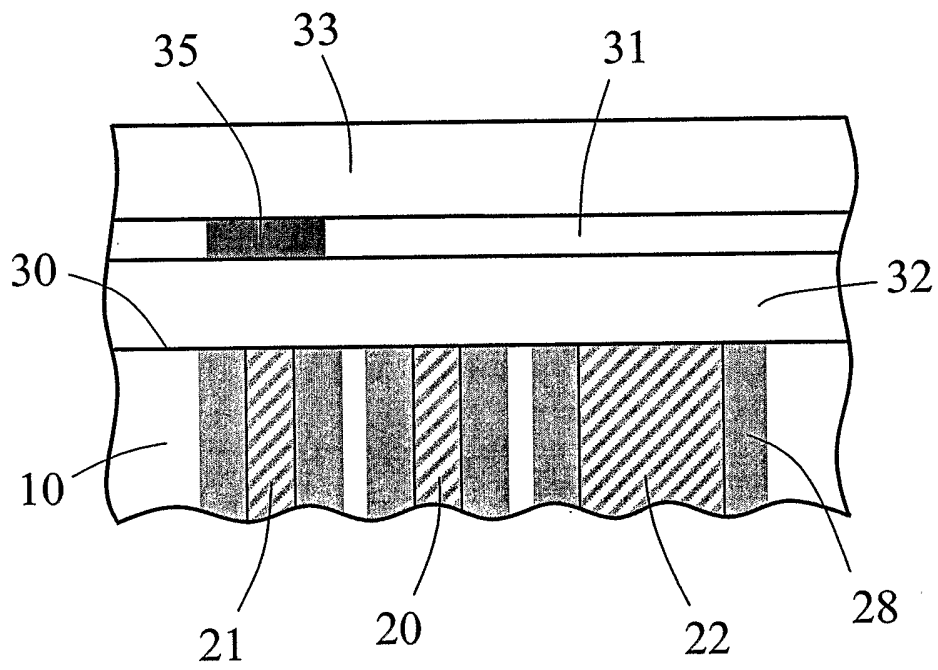

Figure 2B

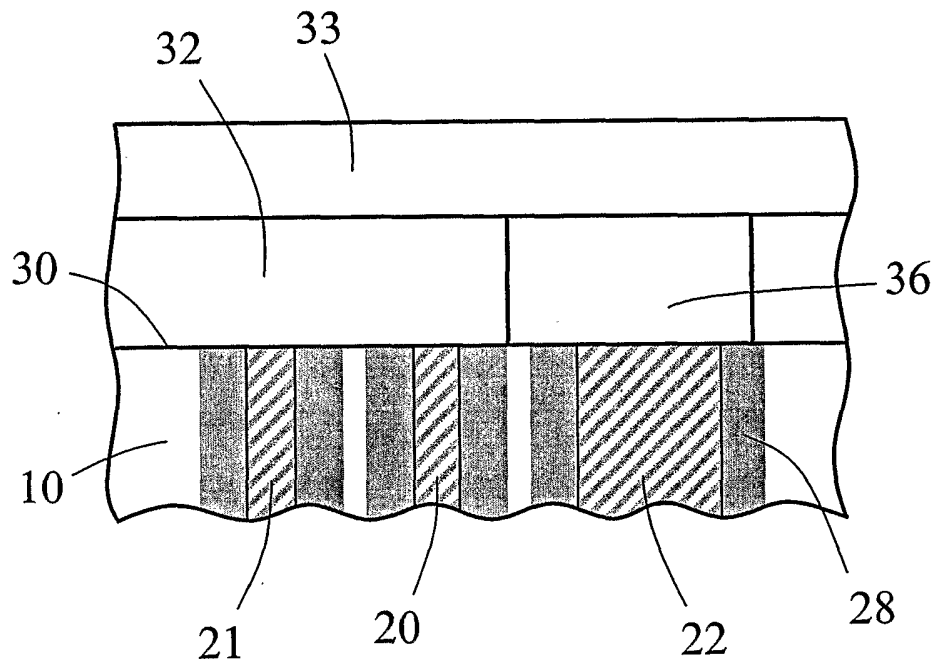

Figure 2C

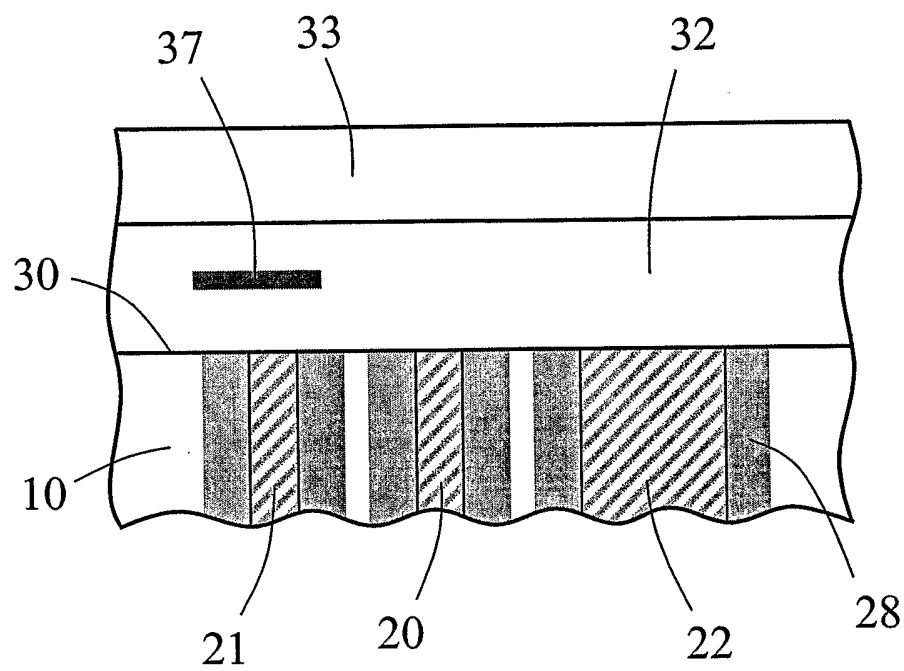

Figure 2D

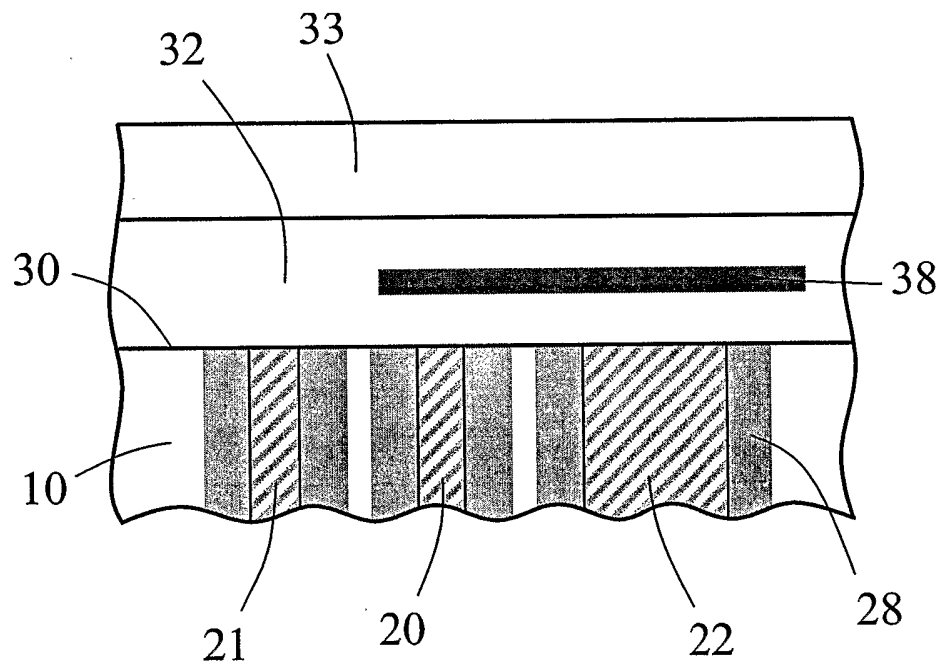

Figure 2E

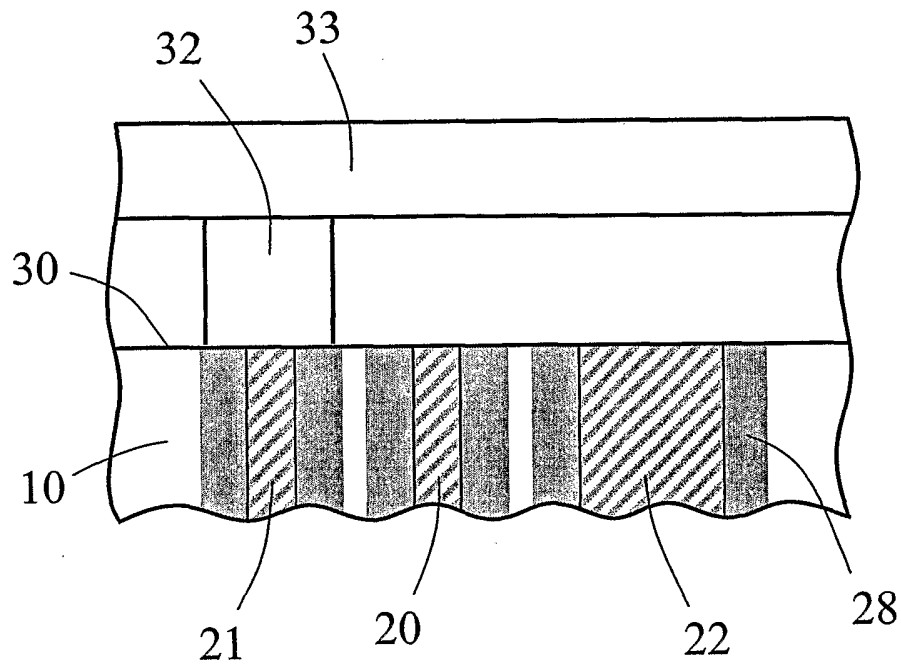

Figure 2F

Fig. 3

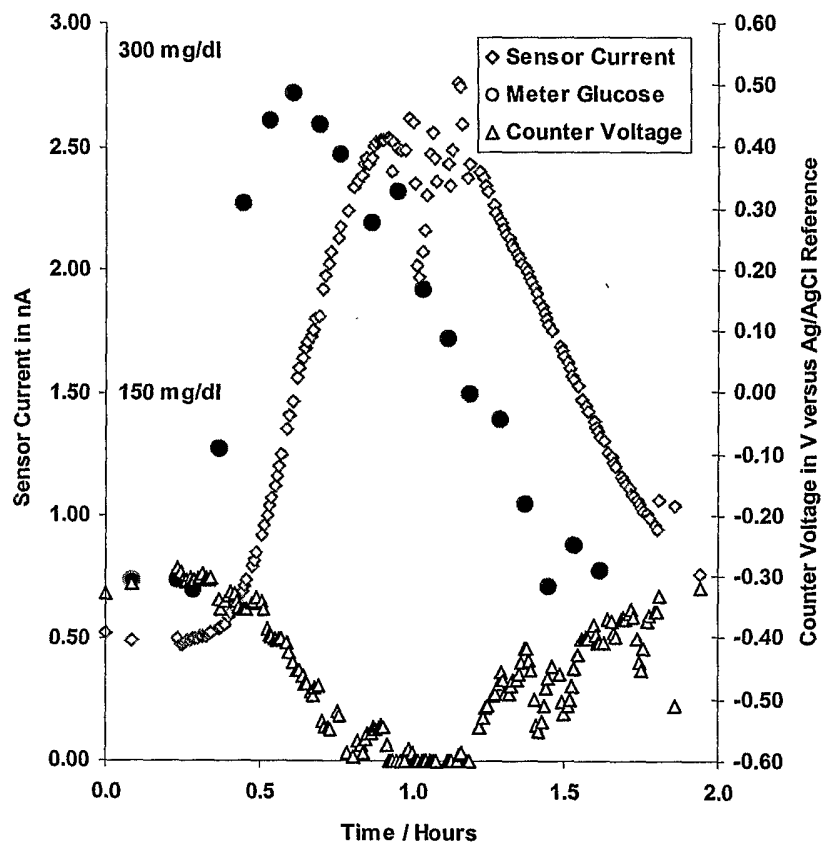

Fig. 4

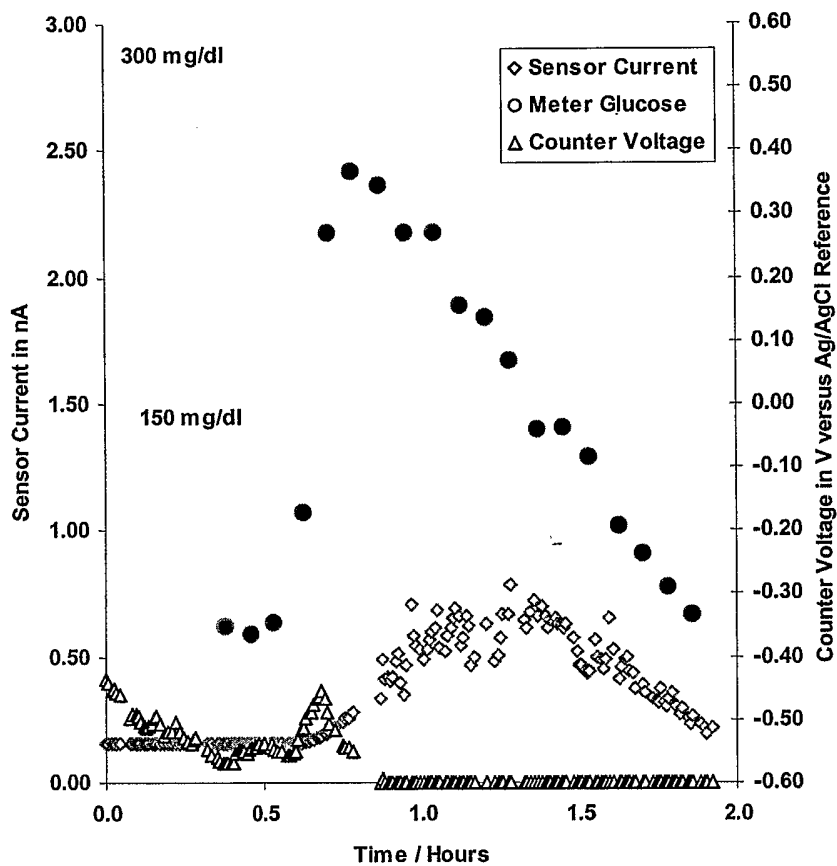

Fig. 5

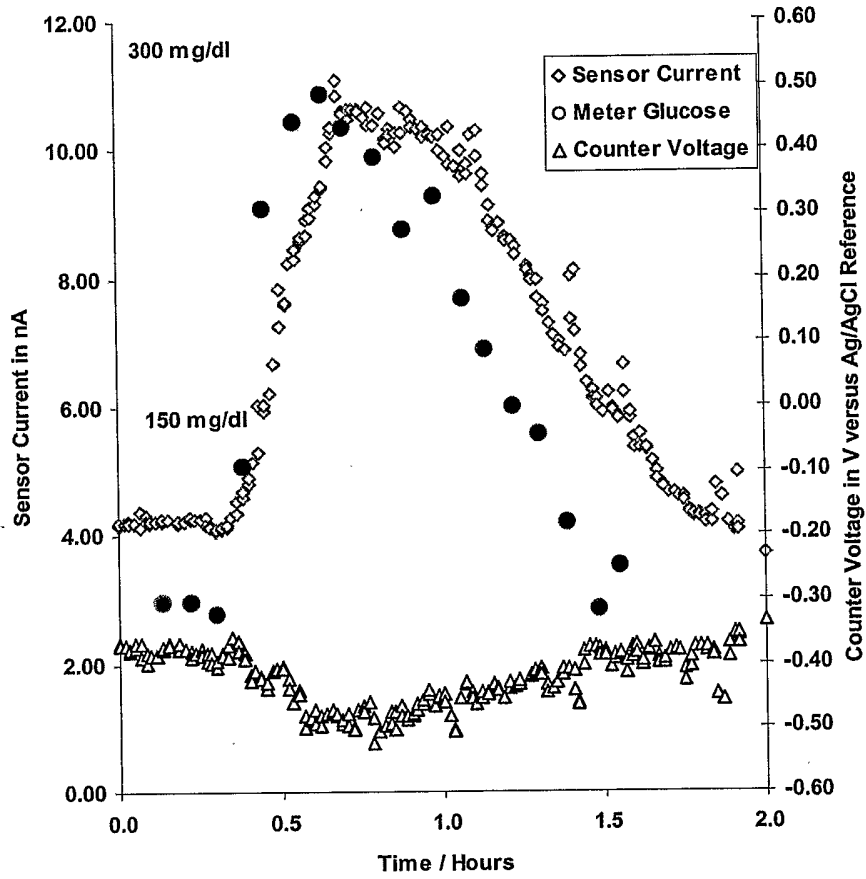

Figure 6A

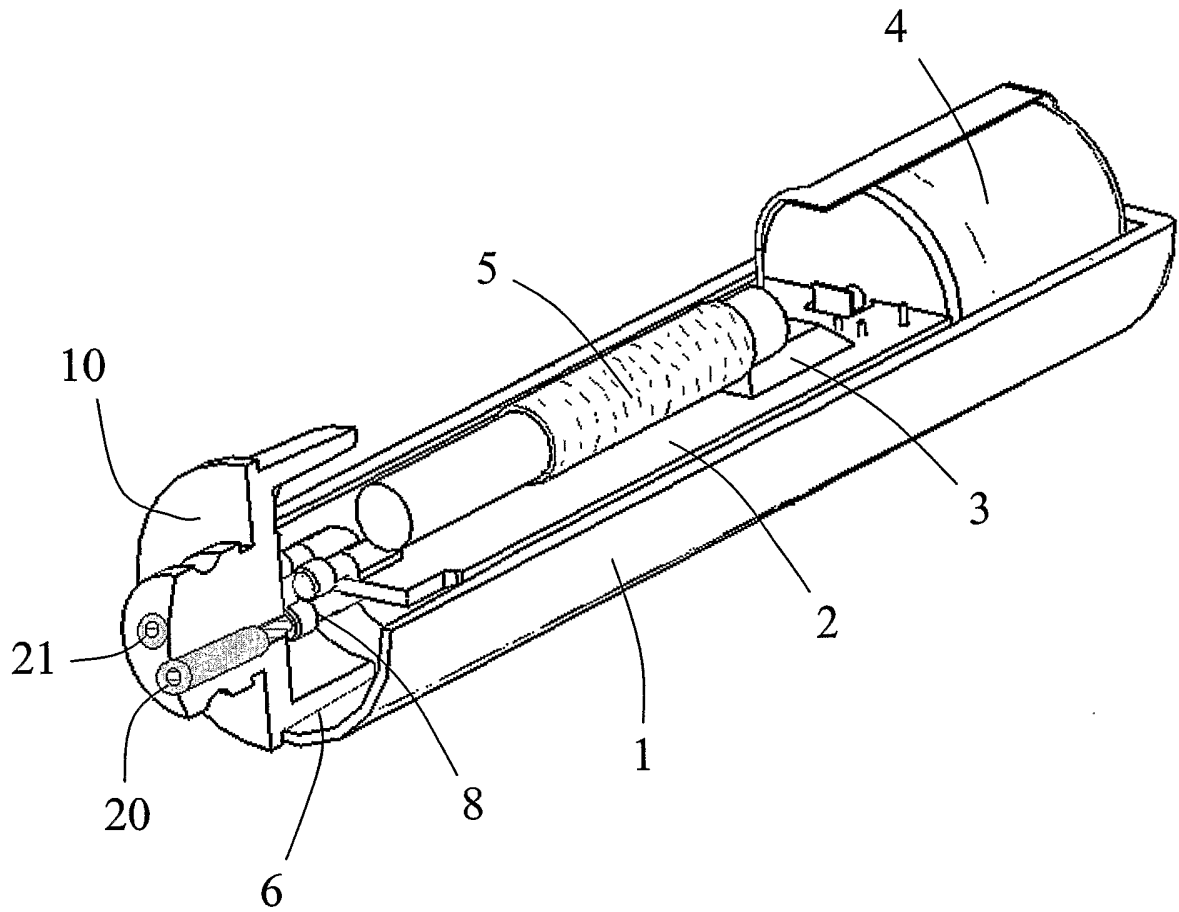

Figure 6B

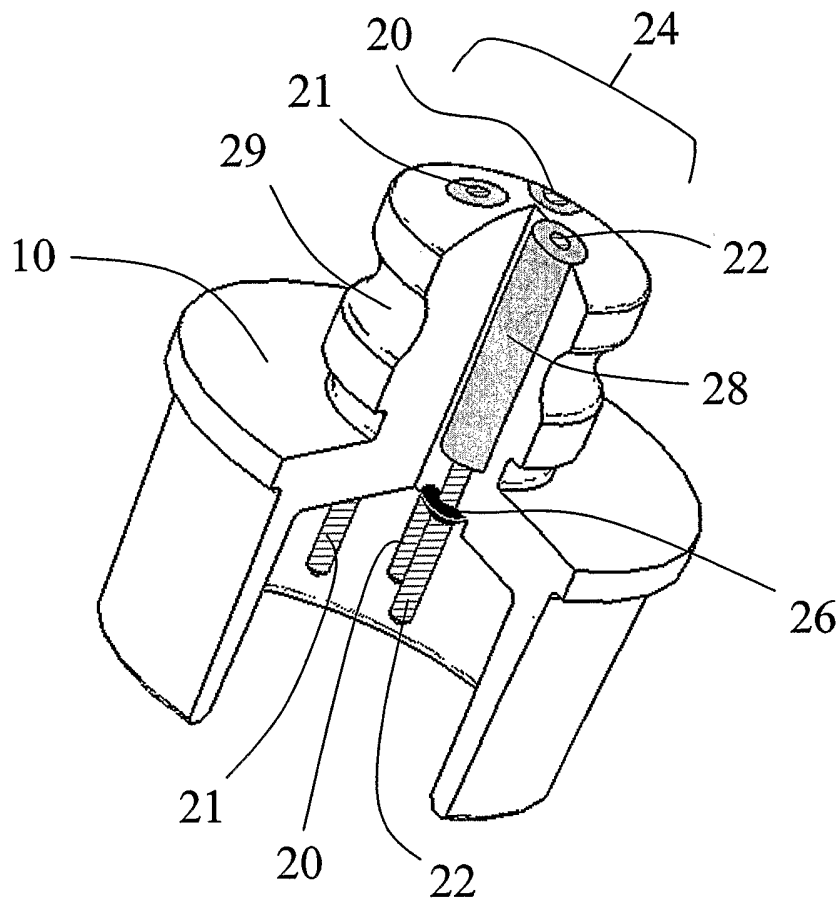

FIG 7

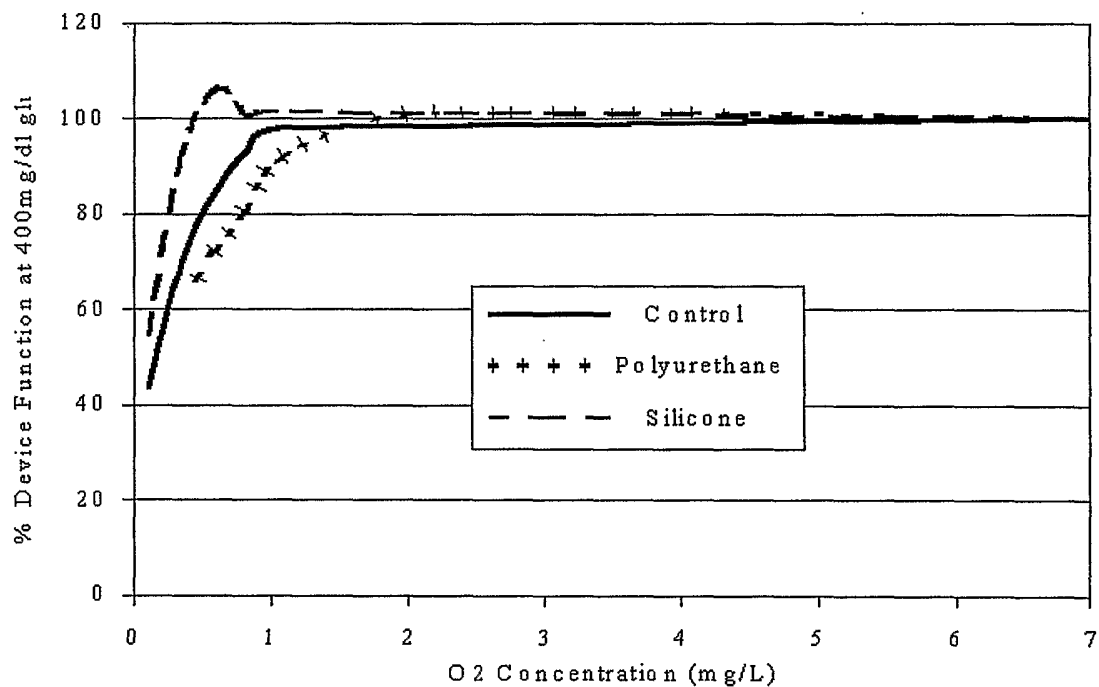

Figure 8

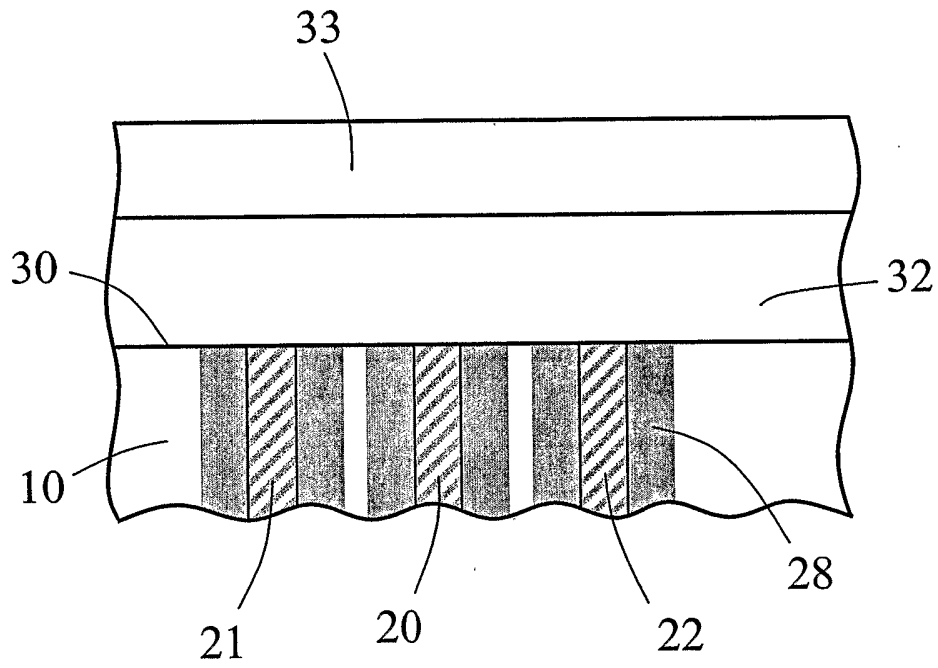

FIG 9

