

[54] METHOD AND APPARATUS FOR CASING BOOKS AND PRODUCT THEREOF

[75] Inventors: William H. Abildgaard, Los Altos Hills; Charles T. Groswith, III, Los Altos, both of Calif.

[73] Assignee: Velo-Bind, Inc., Sunnyvale, Calif.

[22] Filed: Sept. 22, 1972

[21] Appl. No.: 291,206

Related U.S. Application Data

[63] Continuation-in-part of Ser. No. 146,648, May 25, 1971, Pat. No. 3,749,422.

[52] U.S. Cl. 11/1 R

[51] Int. Cl. B42c 11/00

[58] Field of Search 11/1 R, 3, 4; 281/21 R

[56] References Cited

UNITED STATES PATENTS

1,274,154 7/1918 Etheridge 11/4
3,188,114 6/1965 O'Brien et al. 281/21 R

FOREIGN PATENTS OR APPLICATIONS

1,077,181 3/1960 Germany 11/4

Primary Examiner—Lawrence Charles
Attorney, Agent, or Firm—Julian Caplan

[57] ABSTRACT

In one form of the invention, a case for a book has a

spine strip of cover material coated with pressure-sensitive adhesive in the spine area and initially separate covers on either side of the spine area. A pad of resilient material such as polyurethane foam is positioned in the center of the spine area of the case and is coated on its exposed surface with pressure-sensitive adhesive initially protected by release paper, which is removed prior to attachment of an uncased book thereto. The spine strip overlaps the spine edges of the covers and is secured thereto by the pressure-sensitive material. The uncased book is preferably provided with end leaves having pressure-sensitive adhesive initially protected with release paper fabricated in a manner to facilitate stripping off the release paper. Apparatus used to case the book has a table on which the case is positioned and clamps pivoted to the table, and movable relative to each other depending on the thickness of the uncased book. In a preferred form of the invention, edge guides for the covers move inward and outward in relation to movement of the clamps toward and away from each other to center the covers relative to the uncased book. The method consists in pivoting the clamp to bring the spine edge of the uncased book into contact with the pressure-sensitive spine pad of the case and then to strip away the release paper from the end leaves so that the latter adhere to the insides of the top and bottom covers of the case.

2 Claims, 13 Drawing Figures

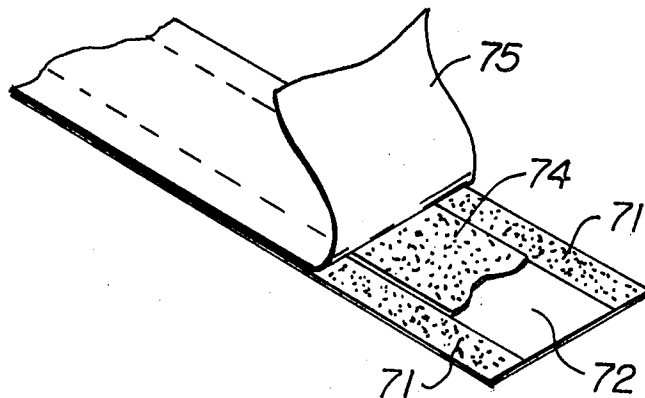

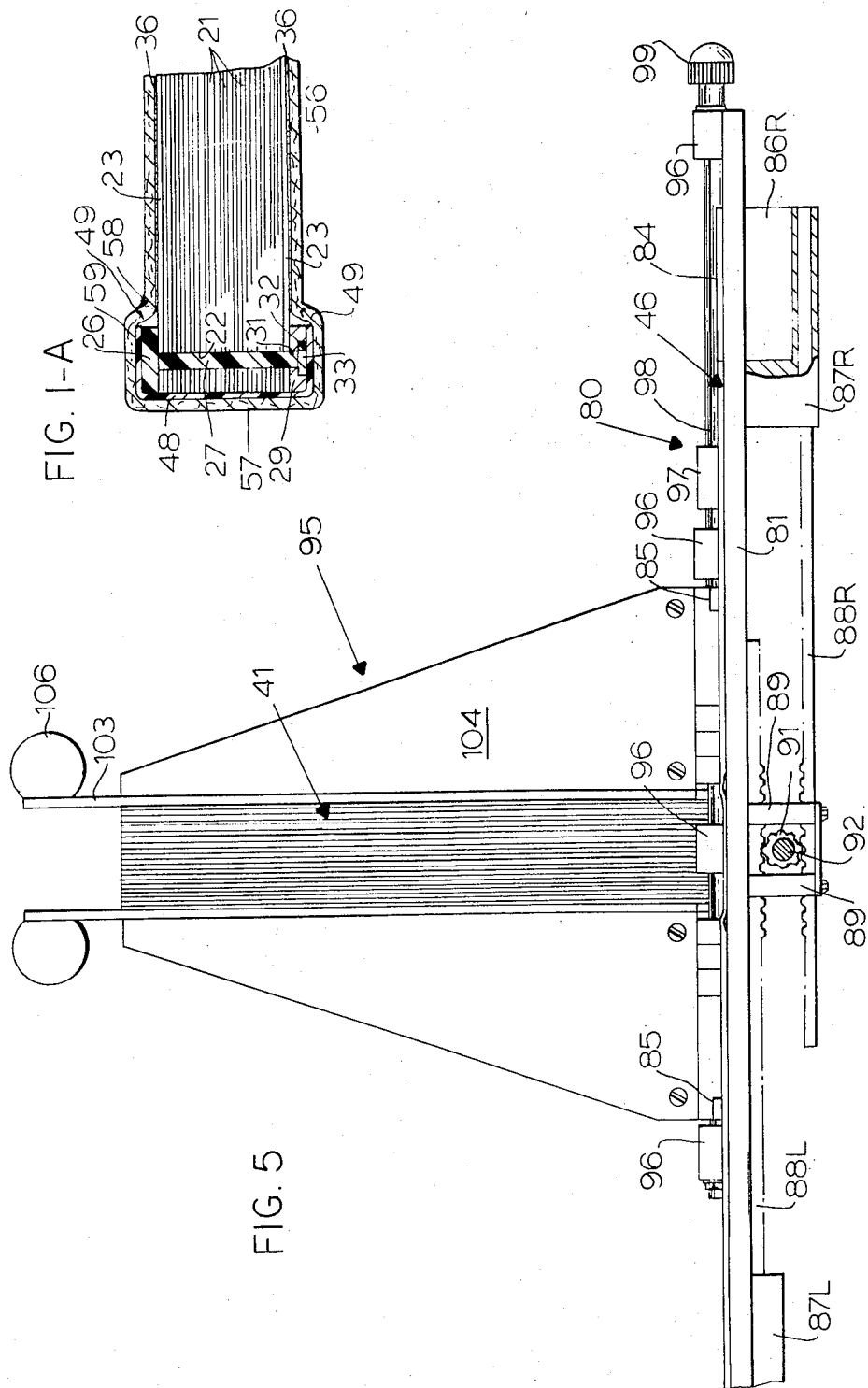
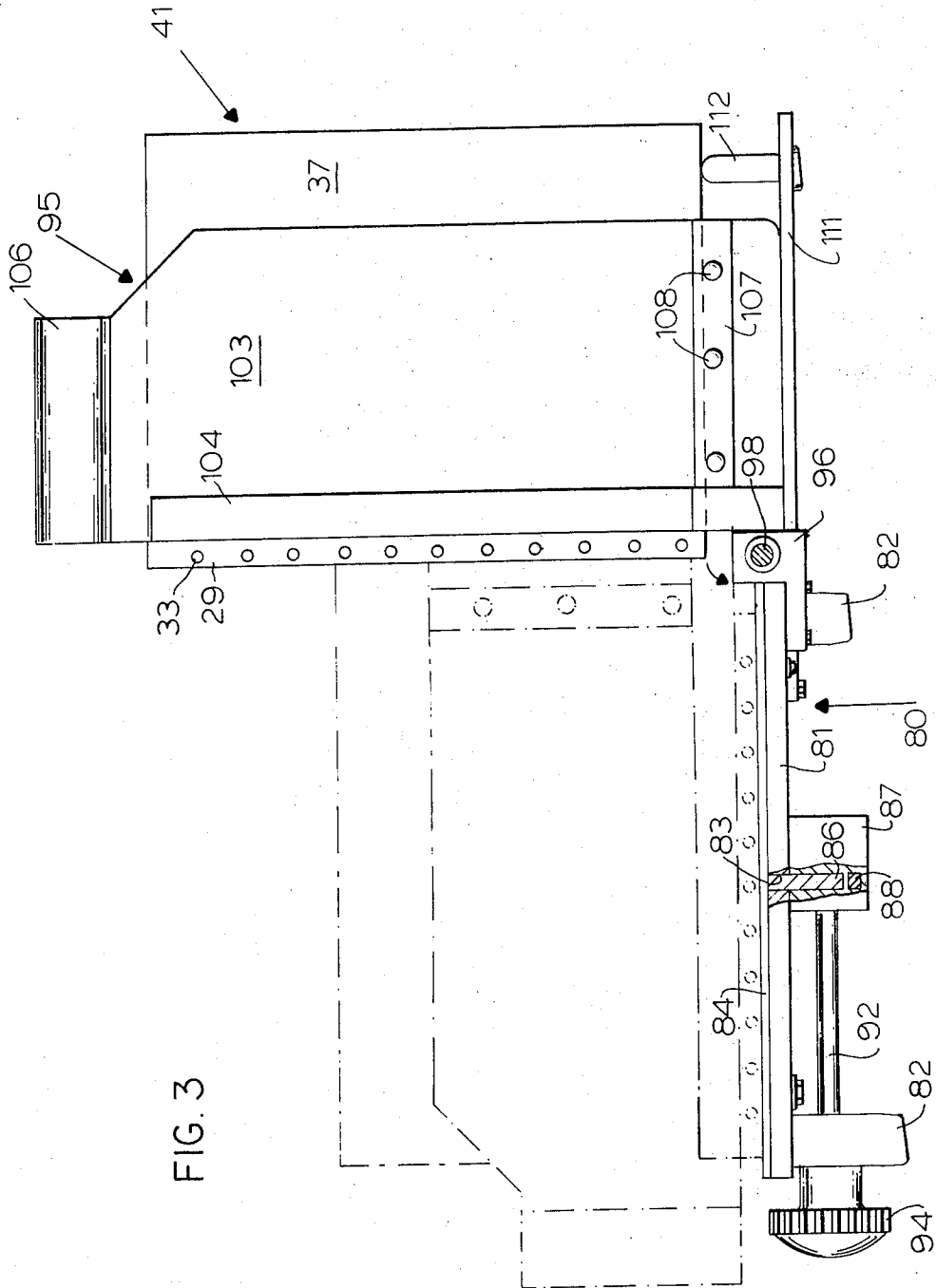

FIG. 5



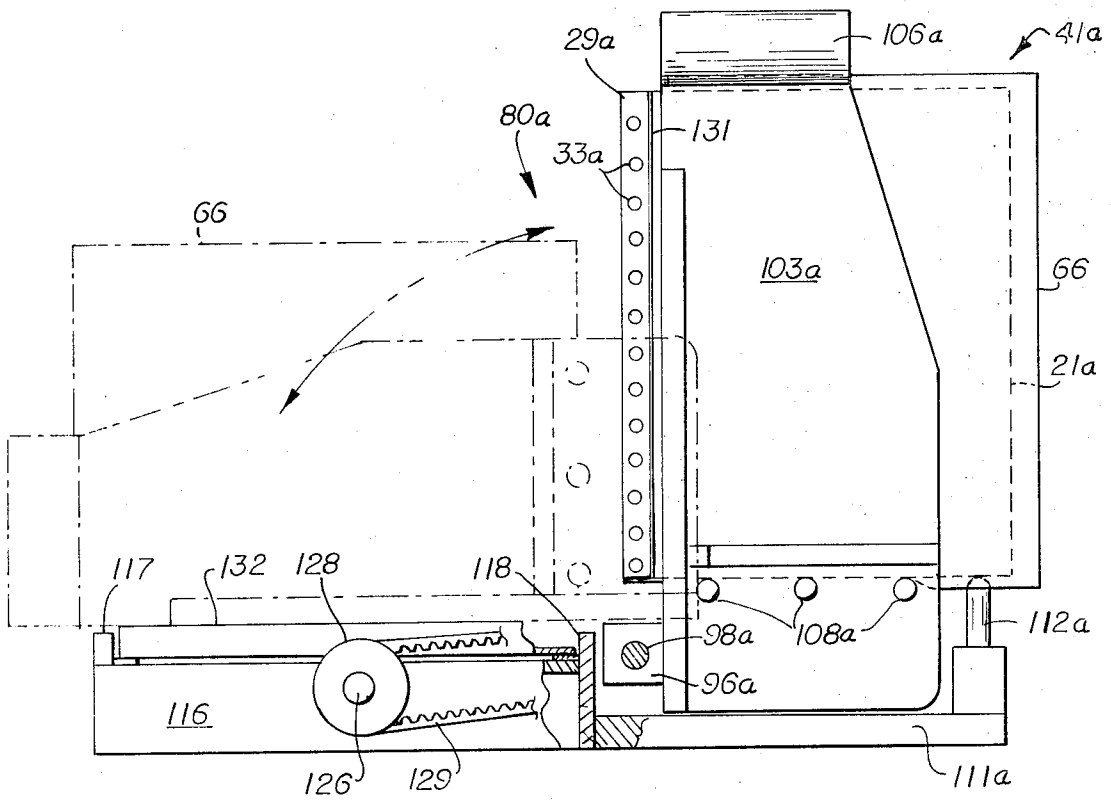

Fig. 9

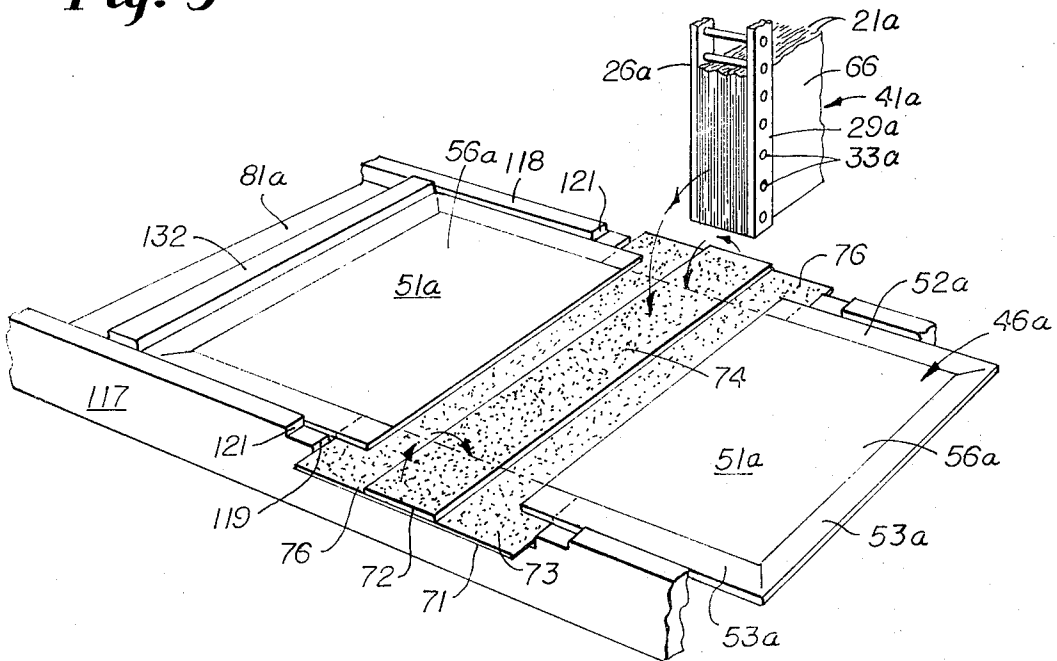

Fig. 11

METHOD AND APPARATUS FOR CASING BOOKS AND PRODUCT THEREOF

This application is a Continuation-In-Part of U.S. Pat. application Ser. No. 146,648, filed May 25, 1971 now U.S. Pat. No. 3,749,422 issued July 31, 1973.

This invention relates to a new and improved method and apparatus for casing books and to the product thereof.

A principal object and advantage of the present invention is to greatly reduce the number of operations required to case an uncased book. The labor required is very materially reduced; the use of existing bindery equipment is almost entirely eliminated; and the amount of additional equipment required is minimal and inexpensive. More particularly, conventional book binding requires a large number of sewing, gluing, beading and rounding steps, each of which normally requires specialized equipment and, further, the casing in of the uncased book requires gluing and fabricating steps. All of the foregoing steps are either eliminated or greatly simplified by practice of the present invention.

A further feature of the invention is the reduction in the amount of skilled labor required. The operator of the equipment used to practice the present invention does not require extensive training in order to practice the method of the invention.

One of the particular features of the invention is the fact that pressure-sensitive adhesive is applied to the end leaves of the book. In accordance with conventional manufacturing practices, the pressure-sensitive adhesive is first applied to release paper which has previously been coated so that when the adhesive is brought into contact with the end leaf, the adhesive sticks to the end leaf and does not stick well to the release paper. Accordingly, when the release paper is stripped off, the pressure-sensitive adhesive remains with the end leaf and is exposed.

Another feature of the invention is the assembling of the uncased book to its case. After the spine edge of the uncased book is caused to adhere to pressure-sensitive material which is positioned on the spine area of the case, the release paper for the pressure-sensitive material of the end leaf is removed, and the end leaves are then caused to adhere to the inside of the covers of the case.

Another principal feature and advantage of the invention is the provision of a rapid and convenient means for locating the case and the book relative to each other.

Still another feature of the invention is the provision for rapid and convenient means for attachment of the book to the spine of the case.

A still further feature of the invention is the provision of a rapid and convenient means for attachment of the end leaves to the case.

An object of the invention is to provide an apparatus and method for assembly of the uncased book and the case with the use of equipment which resembles in appearance, size and ease of operation standard office equipment. Further, the operation of the equipment requires relatively unskilled labor.

Other features of the invention are the substantial reduction in the initial cost of equipment required to assemble the uncased book and case, a substantial reduction in floor space required as compared with commer-

cial binderies, and the reduction in maintenance costs of the equipment.

Another object of the invention is to provide a new and improved book construction. In accordance with a preferred form of the invention, the book comprises a case having front and back covers and spine covering for the spine area of the book which overlaps the spine edges of the covers. Initially, the spine covering projects outward beyond the top and bottom edges of the front and back covers and is then turned inward to form top and bottom turn-ins which conceal the top and bottom spine edges. Centrally disposed in the spine area is a pad of resilient material such as polyurethane foam. Preferably, both the spine material and the pad are coated with pressure-sensitive material which is initially protected by a release paper. At the time of assembly of the uncased book to the case, the release paper is stripped from the spine material, the spine marginal edges of the front and back covers are caused to adhere to the spine material, the extensions at top and bottom are turned in and thereupon the spine edge of the uncased book is brought into contact with the pad and adheres thereto.

The foregoing book construction provides great utility in that a case for a book can be assembled which fits the thickness of the uncased book without special fabrication of the spine. In other words, a single spine strip provided with a resilient pad will accommodate a wide range of book thicknesses. The extent to which the spine material overlaps the spine margins of the front and back covers is dependent upon the thickness of the uncased book. Accordingly, the different sizes of cases which must be stocked to accommodate a range of thicknesses of uncased books is materially reduced.

Other objects of the present invention will become apparent upon reading the following specification and referring to the accompanying drawings in which similar characters of reference represent corresponding parts in each of the several views.

In the drawings:

FIG. 1 is a perspective view of one form of book in accordance with the present invention and the case therefor with the release paper for the end leaves still in position, one of the covers being open.

FIG. 1A is a fragmentary, sectional view to the structure of FIG. 1 with the covers closed and release papers removed.

FIG. 2 is a top plan view, partially broken away in section, of one form of apparatus for assembling an uncased book and case.

FIG. 3 is a side elevational view from the right of FIG. 2.

FIG. 4 is a rear elevational view of the structure of FIG. 2.

FIG. 5 is a front elevational view of the structure of FIG. 2, partially broken away to reveal interior construction.

FIG. 6 is a perspective view of another form of book in accordance with the present invention and the case therefor with the release paper still in position, the covers of the book being open.

FIG. 7 is a perspective view of the book of FIG. 6 fully assembled and partially broken away in section to reveal internal construction.

FIG. 8 is a fragmentary view similar to FIG. 2 of modified apparatus.

FIG. 9 is a view similar to FIG. 3 of the modification of FIG. 8.

FIG. 10 is a view similar to FIG. 5 of the structure of FIG. 8.

FIG. 11 is a fragmentary, schematic, perspective view illustrating steps in the practice of the method of construction of the book of FIG. 6.

FIG. 12 is a fragmentary perspective view of a spine covering in accordance with FIGS. 6 and 7.

Reference is made to U.S. Pat. No. 3,596,929 wherein an uncased book 41 which may be used with the present invention is illustrated and described. It will be understood that the uncased book may be considerably modified from that shown in said application in that the book may be fabricated by sewing, gluing, stapling or other means. However, the book shown in said U.S. Pat. No. 3,596,929 is a preferred construction. Such a book 41 is formed of a plurality of sheets 21 formed with apertures 22 adjacent the spine margins thereof. The uncased book is held together by means of a first plastic strip 26 having integral projecting thermoplastic studs 27 spaced to fit through the holes 22 and a second plastic strip 29 formed with similarly spaced holes 31 preferably having external counterbores 32 in which rivet heads 33 are formed on the severed ends of studs 27 by passing a hot knife through said studs spaced beyond said second strip and then moving the hot knife toward the second strip to form rivet-like heads on said studs. Apparatus and method for thus fabricating a book are claimed in U.S. Pat. No. 3,608,117. Other apparatus may be used. End leaves 23 are provided which fit on the top and bottom of the stack of sheets 21, the spine marginal edges of the end leaves 23 being apertured and receiving the same studs 27 which secure the sheets 21 to the strips 26, 29.

One of the features of the present application is the use of pressure-sensitive adhesive 36 on at least a portion of each end leaf 23. Initially, such adhesive 36 is protected from contact with other objects by release paper 37. Release paper 37, as conventionally manufactured, is ordinary Kraft paper which is coated with polyethylene on both sides so that the paper does not absorb solvents or moisture and the polyethylene coating is stable. At least the side of the release paper to which the adhesive is applied is coated with a silicone material to facilitate stripping.

Adhesive 36 is usually an acrylic, cross-linked acrylic, nitrile rubber or other polymer which is initially dissolved in a solvent as commercially available. A coating between 4 and 6 mils thick is applied to the silicone coated surface of the release paper 37 and then the solvent is driven off by drying in an oven so that the adhesive layer 36 is about 1 mil or less in thickness. Such release paper 37 coated with adhesive 36 is then laminated to the end leaf 23 and rolled so that the adhesive 36 sticks to the end leaf 23. The fabrication of the end leaf 23, adhesive 36 and release paper 37 is an adaptation of general commercial practice in the pressure-sensitive adhesive art. In accordance with the present invention, in the form of the invention shown in FIG. 1, a slit 38 is formed in the release paper 37 immediately outside each strip 26 or 29. By pulling the release paper 37 away from the adhesive 36 commencing at the slit 38, the release paper is removed, exposing the adhesive 36. When the top cover 56 of the case 46 is closed, adhesive 36 causes the end leaf 23 to adhere

to the inside cover, as subsequently explained, and thus the case and cover are assembled.

Case 46 is likewise subject to variation. One preferred form, shown in FIGS. 1-5, employs cover material 47 of vinyl, leather or other suitable substance and to the center of the case 46 extending vertically in the completed book is a resilient spine strip 48 which is pressure-sensitive on both surfaces and is preferably originally covered by release paper 48a (see FIG. 2) which is stripped off at the commencement of the assembling operation. Immediately to the outside of the strip 48 is a hinge forming area 49 which is the thinnest part of the case. Immediately outside of each hinge forming area 49 are boards 51 of cardboard or similar material. The top and bottom margins of the cover material 47 are folded inward in top and bottom turnins 52 at the top and bottom edges of the book, only partially covering the boards 51. Similarly, on each outer edge an edge turnin 53 of the material 47 is formed and the corners 54 are preferably mitered, all as in accordance with conventional case manufacturing operations. Thus, front and back covers 56 and an intermediate central spine cover 57 are provided. In the ultimate fabrication of the book, hinge creases 58 are formed immediately inward of covers 56 and beads 59 formed immediately inward of the hinge creases 58.

In assembling the uncased book 41 to the case 46 of FIGS. 1-1A, as is further set forth in the description of FIGS. 2-5, the spine edge of the uncased book 41 is caused to adhere to the pressure-sensitive resilient spine strip 48. The completion of this operation is shown in FIG. 1. As shown in FIG. 1, the top cover 56 (and the bottom cover as well) is unfinished in that the board 51 is shown merely covered by the turned in top and bottom portions 52 and edge turnin 53. The ultimate position of the end leaf 23 which conceals the board 51 is shown in dot-and-dash lines in the inside of top cover 56.

In the form shown in FIG. 1, slit 38 is formed extending from top to bottom of the release paper 37 immediately inside the hinged area 58. As a further step in the completion of the book, the release paper 37 is peeled back from the adhesive 36 of the end leaf 23, the beginning of this operation being shown in the dot-and-dash line portion of the uncased book 41 of FIG. 1. The release paper 37 is completely removed and the top cover 56 is then closed causing the adhesive 36 to adhere to the inside of the board 51 and the portions of the turned-in portions 52, 52 and 53 within the dot-and-dash lines. The end leaf 23 then permanently adheres to the cover 56.

As shown in FIG. 6, adhesive 36a is preferably applied only partially over the width of the release paper 37a but terminates in line 64 spaced inward from the left-hand margin of the paper 23a. Accordingly, as shown in FIG. 6, when the release paper 37a is peeled back, the edge 64 of the adhesive 36a is spaced outward of the inner margin of the end leaf 23a a predetermined distance. The space between the edge 64 and the inner edge of the sheet 23a provides room for the plastic strip 26a. To facilitate stripping of the release paper 37a, a folded over portion of extended width is connected to the outer edge of end leaf 23e. Sheet 66 is then folded to overlie the release paper 37a so that the area where the strip 26a is to be applied is clear and accessible during the makeup of the uncased book. After the uncased book is inserted in the case, it is desirable

that the sheet 66 protrude outside the outer edge of the book so that it may be gripped with the covers closed and pulled to expose the adhesive 36a and to make it possible for the end leaf 23a to be bonded to the inside of the cover without the necessity of opening the book. Adhesive film 36a breaks at line 64 when tab 66 is pulled to the right, and release paper 37a is stripped from adhesive 36a on end leaf 23a. Preferably sheet 66 is formed integral with release paper 37a rather than as a separate element.

Directing attention to the modification shown in FIGS. 6 and 7, the case 46a, instead of being in a single piece, comprises three separate members which are initially separate and are assembled only after the thickness of the uncased book 41a with which the case is to be used has been determined. The front and back covers 51a are each a discrete member consisting of a suitable cover material 47a which covers the outsides of boards 51a and the edges of the boards are finished off by top and bottom turn-ins 52a and side turn-in 53a. However, the edge of the cover 51a which is adjacent the spine of the book may be unfinished.

Spine binding 71 may be of a material such as vinyl, leather, cloth or the like and may be the same texture and color as material 47a but preferably a contrasting color. The length of binding 71 is greater than the length of the unbound book 41a to be cased. The width of binding 71 is substantially greater than the spine thickness of uncased book 41a so that, as best shown in FIGS. 7, the binding 71 overlaps the spine edges of cover material 47a. The amount of said overlap is variable depending upon the thickness of uncased book 41a. In other words, in a preferred embodiment of this invention, the spine binding 71 is of a standard width which can be used in connection with a range of thicknesses of uncased books, the amount of the overlap being dependent upon the thickness of uncased book 41a. Prior to assembly of the cased and uncased books (see especially FIG. 11), there is a resilient pad 72 centrally disposed relative to binding 71. This pad is of polyurethane foam or similar resilient material. Both pad 72 and the inner surface of binding 71 are coated with a pressure-sensitive adhesive 74, 73, respectively. Prior to use, the pressure-sensitive material 73, 74 is protected by release paper 75 which is peeled away immediately before use.

As indicated in FIG. 11 by reference numeral 76, the binding 71 and pad 72 initially extend beyond the top and bottom edges of cover 56a. In the completed book, however, the extensions 76 are folded over the covers 56a and adhere to the boards 51 and self-adhere to pad 72 and binding 71. Thus, the edges of the book in the spine area are finished off (see FIGS. 6 and 7).

In other respects, the binding of FIGS. 6-11 is similar to the preceding modification and the same reference numerals followed by the subscript *a* are used to designate corresponding elements.

The apparatus 80 illustrated in FIGS. 2-5 may be used to assemble the uncased book 41 to the case 46. End leaves 23 of the type illustrated and described in FIGS. 1 or 6 may be applied to the uncased book 41 prior to its being positioned in the apparatus 80.

The case 46 is placed on table 81 which is shown in the accompanying drawings being horizontal but is actually preferably downwardly rearwardly inclined as is best shown in FIG. 3. The angle which the table 81 assumes is governed by the length of the feet 82 which

are positioned below the four corners of the table. Stops 85 at the rear edge of table 81 locate case 46 in a rearward sense. On either side of table 81 is a transverse slot 83. Wings 84 are located on either side of the apparatus sliding over the surface of table 81 and each having a downward extension 86 which fits through slot 83. The extension 86 slides laterally in a block 87 fixed to the bottom of table 81 and its lower end is fixed to a rack 88. There is one rack 88R on the right hand side of the machine at a lower elevation than the corresponding rack 88L of the left hand side. The inner ends of the racks 88L and 88R slide through a central block 89 on the underside of the middle of the table 81 and mounted for rotation in block 89 is a pinion 91 connected to forwardly extending shaft 92 which is mounted in a bearing support 93 along the bottom of the front edge of the table 81 with a centering knob 94 on the exterior of the apparatus. By turning knob 94 the pinion 91 is likewise turned and this causes racks 88L and 88R to move in and out equi-distant amounts in opposite directions and thereby move the wings 84 inwardly and outwardly relative to the center of the Table 81 for the purpose of accurately centering the case 46 received between the inner edges of the wings 84 relative to the center line of the table.

Pivoted to the rear edge of table 81 is a clamp 95 which receives the uncased book and is used to press the spine edge of the book against the spine strip 48 of the case 46 as hereinafter appears. Bearing blocks 96 are located on the rear edge of table 81 and receive shaft 98 which extends from the right hand edge of table 81 to a position to the left of the center thereof. Shaft 98 consists of three sections. At the right hand edge is an unthreaded section which is connected by coupling 97 to a right hand threaded section which lies immediately to the left of coupling 97 as viewed in FIG. 2 and extends up to the center of the machine while the shaft 98 to the left of the center of the machine is left hand threaded. Thickness adjusting knob 99 is fixed to shaft 98 on the right hand side of the machine. By turning knob 99, the shafts 98 turn in bearing supports 96. The left and right clamp members 101L, 101R are moved by shaft 98, each having a nut 102 in threaded engagement with shaft 98. Thus, when knob 99 is turned, the nuts 102 move toward or away from each other, bringing the clamp members 101L, 101R toward and away from each other to adjust for the thickness of the uncased book 41 which is held therebetween.

Each member 101 has a plate 103 which oscillates around the center of shaft 98 in a vertical plane. Extending laterally from adjacent the front edge of each plate 103 is an angularly shaped bracket 104 and a handle 106 is attached to each plate forward of angle bracket 104. By squeezing the handles 106 together the uncased book 41 which is between the clamp members 101 may be more tightly gripped. At right angles to angle brackets 104 are gussets 107 positioned adjacent the bottom edges of plates 103. Three transverse rods 108 extend through gussets 107, the ends of rods 108 being fixed to one of the gussets and sliding within holes in the other gusset. The rods 108 insure that the members 101 pivot together rather than independently. Extending rearward of table 81 is a rearward extension 111 on which the lower edges of plates 103 rest in the retracted position of the clamp 95 and extending up from the extension 111 of the rear of the machine is a

leveling boss 112 on which the rear bottom edge of the encased book 41 rests at the time of initial installation. The upper edge of boss 112 is level with the tops of rods 108 so that the uncased book is properly located at the beginning of the assembly operation resting on the tops of rods 108 and boss 112.

In the use of apparatus 80, at the outset, clamp 95 is pivoted to up position (solid lines in FIG. 3) and the uncased book 41 is placed in the clamp 95. For this purpose, knob 99 is turned so that the clamp members 101L, 101R are moved apart a distance slightly greater than the thickness of the book 41. The book 41, with end leaves 23 and release paper 37 incorporated therein as previously explained, are positioned between plates 103 with the strips 26, 29 forward of the front 112. of plates 103 and with the bottom edge of the uncased book resting upon rods 108 and leveling boss 112. The knob 99 is then turned to bring the clamp members 101L, 101R together and to clamp the uncased book into position therebetween. By observation of the distance between members 101L, 101R, or by the use of a gauge (not shown), the width of the spine of the book is estimated and a case 46 having a proper spine dimension is selected. Such case 46 is placed on the table 81 and moved rearward to engage stops 85. Knob 94 is turned so that the wings 84 center case 46 relative to the center of the machine. Release paper 48a, which covers the pressure-sensitive spine strip, is removed exposing the adhesive on the spine strip.

After the case 46 and uncased book 41 have been installed as above described, the operator grips the handles 106 and pivots the clamp 95 in a counter-clockwise direction as viewed in FIG. 3 from the solid line position to the dotted line position. This forces the spine edges of the uncased book 41 against the pressure-sensitive strips 48 and the two parts then stick together. By releasing the grip on the handles 106, the clamp 95 can be pivoted back to its initial position, leaving the uncased book 41 in position on the case 46. Thereupon, when the end leaves 23 of FIG. 6, for example, have been previously installed, the front and rear covers 56a may be closed, the sheet 66 pulled, exposing to the inside of the covers the pressure-sensitive adhesive 36a which then sticks to the boards 51 and to the edges of the turn-ins 52, 53 completing assembly of the book.

Where end leaves 23 such as shown in FIG. 1 have been employed, the assembly of the end leaves to the inside of the cover is accomplished by serially attaching the covers. This is done by pulling off release paper 37 of each end leaf 23 and then closing the cover and pressing it tightly against adhesive 36.

FIGS. 8-10 illustrate an apparatus 80a used to assemble the book of FIGS. 6 and 7. Said apparatus 80a is a modification of the apparatus shown in FIGS. 2-5 and the same reference numerals followed by subscript a are used to designate corresponding parts. In this modification, the table 81a is supported on either side by sides 116 which rest on the supporting surface. Along the front of table 81a is a front edge 117 which projects above the level of table 81a and forms a bottom guide for case 46. Similarly along the rear of table 81a is an upstanding rear edge 118 which forms a top guide for the case. In order to centrally locate the spine binding 71, a center notch 119 is formed in edges 117, 118 and an outer notch 121 of lesser depth is formed outwardly of notch 119. As has heretofore been mentioned, the

spine binding 71 is intended to cover a range of books of varying spine thicknesses. However, in a preferred form of apparatus, the notch 119 and 121 are provided so that two different widths of spine binding 71 may be accommodated, the wider binding material being used for the thicker book and inserted in notches 121. It will be understood that more or fewer notches may be used.

Bearings 114 are formed below table 81a at either end, preferably being formed integrally with the sides 116. Rotatable within bearings 114 is horizontal shaft 126 parallel to shaft 98a and similarly formed with left and right hand threads. Shaft 126 is engaged by nuts 127 which are fixed to wings 84a which reciprocate horizontally on table 81a. Wings 84a have at their outer extremities upward expanding outer edges 132 which form guides for the outer edges of cover 56a. Sprockets 128 are fixed to shafts 98a and 126 and interconnected by sprocket belt 129. Hence when the operator turns knob 99a, jaws 101La and 101Ra move inwardly and outwardly and the wings 84a and the side edges 132 thereof move inwardly and outwardly a corresponding distance. Thus, the spine binding 71 is centered relative to table 81a so that the exposed surface thereof is a predetermined width greater than the thickness of the spine of the uncased book 41a which is held in the clamps 101La and 101Ra.

As best shown in FIG. 8, the jaws 101La and 101Ra each has a plate 103a which has an in-turn flange 131 which grips the unbound book 41a immediately behind the binding strips 26a and 29a when said strips are used.

The apparatus 80a is preferably used to case the book shown in FIGS. 6 and 7 but may be used to case the book shown in FIGS. 1, 1A. The uncased book 41a is preferably of the type shown in U.S. Pat. No. 3,596,929 but may be of other types such as stapled, sewn, glued or otherwise bound books. Initially, the clamp members 101La, 101Ra are in the up position shown in full lines in FIG. 9. The operator turns the knob 99a in proper direction to move the jaws far enough apart to receive the uncased book 41a which is positioned so that its spine edge is forward and its top edge is resting upon the rods 108a. Knob 99a is turned to bring the jaws 101La, 101Ra together with the in-turned flanges 131 immediately behind the plastic strips 26a, 29a if such construction has been used. Movement of knob 99a not only moves the jaws but also moves the wings 84a over the table 81a a corresponding distance. From observation it can be determined whether a narrow or a wide spine binding 71 should be used. The proper binding is selected and it is centered either by notches 119 or 121. Extensions 76 project equal distances beyond the front and rear edges 117, 118. The release paper 75 which initially protects the pressure-sensitive material 73, 74 is removed, exposing such material.

The operator thereupon takes the right hand top bottom cover 56a and positions it so that its outer edge fits against outer edge 132 of wing 84a and its bottom edge is against front edge 117 and its top edge is against back edge 118. The cover 56a is then allowed to drop so that its spine margin overlaps binding 71 and adhesive 73 causes cover 56a to adhere to binding 71. The opposite cover 56a is then positioned in similar fashion. Completion of this step is shown in FIG. 11. Thereupon the extensions 76 at top and bottom are folded back to the

position shown in FIG. 8, and adhesives 73, 74 cohere, finishing off the spine edge of the case.

Thereupon, the operator grips the handles 106a and pivots the jaws 101La, 101Ra forwardly to the dotted line position of FIG. 9 causing the spine edge of the uncased book 41a to be secured by means of adhesive 74 to pad 72. Completion of this operation is shown in FIG. 10. Thereupon, the knob 99a is turned to back off the jaws a sufficient distance to allow the jaws to be returned to up position without moving the uncased book. Thereupon, the front and back covers are closed. By drawing a tool on the operator's thumb along the outside of the cover immediately outwardly of the plastic strips 26a, 29a, the hinge creases 58a are formed along with the beads 58a immediately outwardly of said creases. The operator then grips one of the extensions 66 of end leaf release paper 37a and pulls the release paper 37a out of the book, causing the pressure-sensitive adhesive 36a on the end leaf 23a to adhere to the inside of cover 56a as indicated by dot-and-dash line in FIG. 6. The operation is repeated for the other cover of the book. It will be understood that end leaves 23a of construction other than that illustrated in FIG. 6, such as that shown in FIG. 1, may be used with the apparatus of FIGS. 8- 10 to form the books of FIGS. 6 and 7.

What is claimed is:

1. Apparatus for assembling an uncased book to a case of the type having a flexible spine section having an exposed pressure-sensitive inside surface comprising a table dimensioned to support said case laid out substantially flat with said pressure-sensitive inside surface uppermost, clamp means dimensioned to support an

uncased book with its spine edge exposed and connecting means connecting said clamp means to said table whereby said clamp means may be moved toward said table and the spine edge of a book held in said clamp means and said inside surface forced into engagement with each other, said clamp means comprising a pair of plates located transverse to said table, means for moving said plates toward and away from each other to accommodate books of varying thickness, and guide means inter-connecting said plates to maintain said plates substantially parallel, said guide means further comprising support means for said uncased book locating said uncased book relative to said case.

2. Apparatus for assembling an uncased book to a case of the type having a flexible spine section having an exposed pressure-sensitive inside surface comprising a table dimensioned to support said case laid out substantially flat with said pressure-sensitive inside surface uppermost, clamp means dimensioned to support an uncased book with its spine edge exposed and connecting means connecting said clamp means to said table whereby said clamp means may be moved toward said table and the spine edge of a book held in said clamp means and said inside surface forced into engagement with each other of the middle of said case, said clamp means comprising a pair of plates located transverse to said table, and means for moving said plates toward and away from each other to accommodate books of varying thickness, adjustable means on said table movable toward and away from said clamp means to engage the outer edges of said case to center said case relative to said clamp means.

* * * * *

35

40

45

50

55

60

65