

(19) World Intellectual Property Organization
International Bureau



(43) International Publication Date
2 February 2006 (02.02.2006)

PCT

(10) International Publication Number
WO 2006/010972 A1

(51) International Patent Classification : **A47D 13/10**,
9/02, 9/04

(21) International Application Number:
PCT/IB2004/002142

(22) International Filing Date: 28 June 2004 (28.06.2004)

(25) Filing Language: English

(26) Publication Language: English

(71) Applicant (for all designated States except US): **JETTA COMPANY LIMITED** [CN/CN]; 19 On Kui Street, Jetta House, On Lok Tsuen, Fanling, Hong Kong (CN).

(71) Applicant and

(72) Inventor: **WONG, Sui-Kay** [GB/CN]; Flat G & H, 10th Floor, King Fook Court, 173 Tin Hau Temple Rd., North Point, Hong Kong (CN).

(72) Inventor: **CHEUNG, Kwok, Yau (William)**; Room 1901, King Yuet House, King Nga Court, Tai Po N.T., Hong Kong (CN).

(81) Designated States (unless otherwise indicated, for every kind of national protection available): AE, AG, AL, AM, AT, AU, AZ, BA, BB, BG, BR, BW, BY, BZ, CA, CH, CN, CO, CR, CU, CZ, DE, DK, DM, DZ, EC, EE, EG, ES, FI, GB, GD, GE, GH, GM, HR, HU, ID, IL, IN, IS, JP, KE, KG, KP, KR, KZ, LC, LK, LR, LS, LT, LU, LV, MA, MD, MG, MK, MN, MW, MX, MZ, NA, NI, NO, NZ, OM, PG, PH, PL, PT, RO, RU, SC, SD, SE, SG, SK, SL, SY, TJ, TM, TN, TR, TT, TZ, UA, UG, US, UZ, VC, VN, YU, ZA, ZM, ZW.

(84) Designated States (unless otherwise indicated, for every kind of regional protection available): ARIPO (BW, GH, GM, KE, LS, MW, MZ, NA, SD, SL, SZ, TZ, UG, ZM, ZW), Eurasian (AM, AZ, BY, KG, KZ, MD, RU, TJ, TM), European (AT, BE, BG, CH, CY, CZ, DE, DK, EE, ES, FI, FR, GB, GR, HU, IE, IT, LU, MC, NL, PL, PT, RO, SE, SI, SK, TR), OAPI (BF, BJ, CF, CG, CI, CM, GA, GN, GQ, GW, ML, MR, NE, SN, TD, TG).

Published:

— with international search report

For two-letter codes and other abbreviations, refer to the "Guidance Notes on Codes and Abbreviations" appearing at the beginning of each regular issue of the PCT Gazette.

(54) Title: **BABY BOUNCER ACTUATOR**

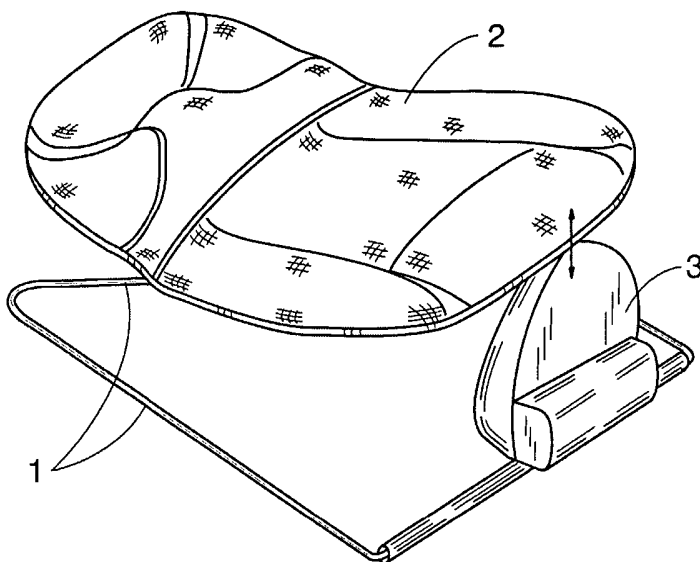

(57) Abstract: The invention provides a novel microprocessor-controlled actuator which bounces a baby bouncer system at soothing frequencies that are optimized for the weight of a baby supported in the baby bouncer system bed. The invention also provides a novel baby bouncer system which includes the novel microprocessor-controlled actuator. In one embodiment, the microprocessor based control system which controls the bouncing motion of the actuator also emits soothing sounds.

WO 2006/010972 A1

BABY BOUNCER ACTUATOR

FIELD OF THE INVENTION

The invention provides a novel microprocessor-controlled actuator which bounces a baby bouncer system at soothing frequencies that are optimized for the weight of a baby supported in the baby bouncer system bed. The invention also provides a novel baby bouncer system which includes the novel microprocessor-controlled actuator.

In one embodiment, the microprocessor based control system which controls the bouncing motion of the actuator also emits soothing sounds.

BACKGROUND OF THE INVENTION

A baby bouncer system comprises a cradle-like seat that supports and rocks a baby in a seated or prone position and a resilient metal frame that includes a base adaptable for support by a relatively uniform surface and an angled segment which extends upwardly to support the seat. The angled segment may be bent downwardly toward the base portion of the frame to provide a gentle rocking movement. The general configuration and design of baby bouncer frames and seats are well known. *See, e.g.*, United States Patent Nos. 6,594,840 and 5,269,591.

Bouncer support frames are spring resilient systems. Thus, the frame will bounce effectively and naturally if subjected to a bouncing rhythm which approximates the baby bouncer's natural frequency. The natural bouncing frequency of a baby bouncer varies depending on the weight of the baby supported in the bouncer seat. (The average weight of a baby varies from around six to around twenty-four pounds).

The most effective rhythm to soothe a baby is believed to be a rhythm close to the human heart beat rate (a rhythm the baby becomes accustomed to in the womb). Consequently, a baby bouncer would preferably bounce at a frequency of from about 70 to about 100 times per minute. Ideally, a properly designed spring-resilient bouncer support frame system would bounce at a natural frequency from 60 to 100 times per minute (approximately 1 Hz to about 1.7 Hz) for baby weight ranges of from about 6 to about 24 pounds.

United States Patent No. 6,629,727 ('727 Patent) discloses an infant carrier having a bouncer mode of operation in which the bouncer mechanism establishes

harmonic vibration. The carrier of the '727 Patent vibrates at a high frequency and the bouncer mechanism generates a low-level force.

Currently available fixed speed actuators (e.g., motorized swing actuators) have not been employed effectively with baby bouncers to either affect a natural bouncing
5 motion or achieve optimum bouncer frequencies.

Therefore, the need exists for baby bouncers and related actuators that automatically support and bounce a baby at an optimum soothing frequency. Such a bouncer would ideally require minimal manual intervention to ensure continuous and soothing bouncing and would have the ability to automatically search and set the
10 actuator's speed to match the naturally bouncing frequency within a range of 60 to 100 times per minute to resemble a natural, gentle harmonic bouncing motion.

SUMMARY OF THE INVENTION

The invention provides a novel microprocessor-controlled actuator which bounces a baby bouncer system at soothing frequencies that are optimized for the weight of a baby
15 supported in the baby bouncer system bed. The invention also provides a novel baby bouncer system which includes the novel microprocessor-controlled actuator.

A microprocessor-controlled actuator of the invention comprises:

- (a) a housing adapted to engage and bounce a baby bouncer system;
- (b) a motion sensor which can generate signals corresponding to baby bouncer system
20 forces and which is enclosed within and supported by the housing;
- (c) a microprocessor based control system which can detect and store the motion sensor signals and which is enclosed within and supported by the housing;
- (d) a DC electric motor which (i) is connectable to a power source, (ii) is in electrical communication with the microprocessor based control system, (iii) during operation
25 receives a supply voltage at a level which is regulated by the microprocessor based control system, and (iv) is enclosed within and supported by the housing;
- (e) a speed reduction mechanism which comprises an axial shaft connected for rotation to and driven by the DC electric motor and which is enclosed within and supported by the housing;

(f) a rotatable eccentric weight which is mounted coaxially on the speed reduction mechanism axial shaft for rotational motion to generate centrifugal force and which is enclosed within and supported by the housing; wherein the microprocessor based control system is calibrated to maintain the DC electric motor supply voltage level at a value which is optimized to maintain baby bouncer system bouncing at a soothing frequency, e.g., about 1 to 2 Hz.

The speed reduction ratio of the speed reduction mechanism is preferably set such that the rotational speed of the actuator's eccentric weight is from about 50 to about 100 times per minute at a microprocessor-controlled DC electric motor supply voltage range of about 40% to about 90% of the maximum motor supply voltage.

When DC power is supplied to the DC electric motor, the motor engages the rotating speed reduction mechanism and rotates the speed reduction axial shaft, causing the eccentric weight to move in a rotational manner to generate the centrifugal force which causes the actuator to bounce the baby bouncer system.

In accordance with the laws of physics, if the actuator speed approximates or matches the natural bouncing frequency of the baby bouncer system supporting a baby, the bouncer system will bounce effectively at the baby bouncer system's natural frequency (resonance). If the actuator speed does not match the natural bouncing frequency, irrespective of whether it is faster or slower than such frequency, the baby bouncer system supporting a baby will not resonate and will either exhibit a low frequency, intermittent bouncing motion or no bouncing motion at all.

As described in detail hereinafter, the microprocessor based control system is calibrated by a method comprising: (1) identifying and storing motion sensor signal frequency values (F_n) over a range of DC electric motor voltage supply levels (V_n); (2) comparing stored F_n values and identifying the maximum motion sensor signal frequency value (F_{max}) and the DC electric motor voltage supply level at F_{max} (V of F_{max}); storing V of F_{max} .

A baby bouncer system of the invention comprises: (a) a resilient support frame adapted for positioning on a relatively level surface; (b) a cradle-like bed attached to and supported by the frame in an elevated position suitable for stable support of a baby; and

(c) a microprocessor-controlled actuator of the invention, wherein the actuator housing can be mounted for transmission of bouncing forces on the resilient support frame.

In one embodiment, the microprocessor based control system which controls the actuator also contains a voice and melody-recording and playback microprocessor which
5 generate signals translatable to soothing sounds which, through a transducer or other appropriate device, are emitted synchronously with baby bouncer system bouncing.

These and other features of the invention are described in detail in the following detailed description.

BRIEF DESCRIPTION OF THE FIGURES

10 FIGURE 1 illustrates a side-view of one embodiment of a baby bouncer system of the instant invention.

FIGURE 2 illustrates a cross-sectional view of one embodiment of an actuator of the instant invention.

FIGURE 3 illustrates a flow chart used to program a microprocessor based control
15 system used to control an actuator of the instant invention.

FIGURE 4 illustrates a force diagram for one embodiment of an actuator of the instant invention which includes two coaxially-mounted rotatable eccentric weights.

FIGURE 5 illustrates a block diagram of one embodiment of a microprocessor based control system used in the instant invention .

20 DETAILED DESCRIPTION OF THE INVENTION

Figure 1 depicts one purely illustrative embodiment of a baby bouncer system of the instant invention.

Referring to Figure 1, resilient support frame 1 is adapted for positioning on a relatively level surface. Cradle-like bed 2 is attached to and supported by resilient
25 support frame 1 in an elevated position suitable for stable support of a baby. Microprocessor-controlled actuator 3 can be affixed to resilient support frame 1 through any number of known means including but not limited to snaps, clamps, straps, detents, locks, and pins and is engaged for the transmission of bouncing force to bounce bed 2. In
30 one embodiment, microprocessor-controlled actuator 3 hangs from resilient support frame 1 and transmits bouncing forces to the frame. Preferably, actuator 3 is attached only to the bouncing portion of bed 2 and detects and matches the natural bouncing

frequency of resilient support frame 1. Most preferably, actuator 3 generates a gentle pull and push force at a rhythm matched to the natural vibrating frequency of resilient support frame 1.

Figure 2 illustrates a single eccentric weight embodiment of an actuator of the instant invention which includes and is enclosed and supported within housing 4. Referring to Figure 2, DC electric motor 5 is in electrical communication through wires 33 to microprocessor based control system 11. DC electric motors used in the instant invention are preferably powered by an actuator battery pack system, a remote battery pack system, or a wall outlet electric power-source. The power supply voltage is around twelve volts or less, and is preferably from about 6.0 to about 7.2 volts with an alkaline or rechargeable battery power supply.

Suitable DC electric motors which can be used in the invention are known to those of ordinary skill in the art. DC electric motors which can be used in the instant invention include, but are not limited to, belt driven, coupled inline, and single shaft DC electric motors. Preferably, the DC electric motor is designed to operate within a range of from about 4.5 to about 7.2 volts. Specific examples of some of the DC electric motors which can be used in actuators of the invention include but are not limited to Mabuchi carbon brush or precision metal brush direct current motors such as models RC260RA-18139, RC 280RA-20120 and other equivalents.

In Figure 2, microprocessor based control system 11: (1) is in electrical communication with a DC power source through voltage regulators 13; and (2) is in electrical communication through wires 35 to motion sensor 19 comprising magnetized weights 17 connected by spring wire 15 and reed switch 21. Microprocessor based control system 11 comprises circuitry which generates signals representative of soothing sounds and is also in electrical communication through wires 37 to transducer 9 for transmission of such soothing sounds. DC electric motor 5 is connected by mechanical linkage 7 to speed-reducing mechanism 23. Eccentric weight 29 is mounted on rotating member 31, which is coaxially mounted on axial shaft 27 of speed-reducing mechanism 23.

When voltage is supplied to DC electric motor 5, DC electric motor 5 engages and rotates axial shaft 27 of speed-reducing mechanism 23 through mechanical linkage 7,

thereby causing rotating member 31 and eccentric weight 29 to rotate and swing in a pendulum-like rotational movement within eccentricity radius 25 and agitate actuator housing 4.

Pulse width modulation (PWM) circuits comprising a power transistor motor drive circuit or linear voltage regulator circuits are preferably used to regulate the voltage supply to the DC electric motor. Power transistor motor drive circuits which can be used to regulate motor voltage supply include but are not limited to Sony transistor 2SD882. Linear voltage regulator circuits which can also be used to regulate motor voltage supply include but are not limited to the National Semiconductor LM 317 adjustable regulator.

Motion sensors used in actuators of the invention include the magnet and reed switch system illustrated in Figure 2, as well as other motion switch systems, including but not limited to a momentary contact motion switch, a mercury switch, and an infra-red motion sensor.

Speed-reducing mechanisms which can be used in actuators of the invention include but are not limited to the pulley and belt system as illustrated in Figure 2, as well as gear trains, frictional wheels, chain and sprocket systems, and other known mechanical linkage systems.

In an actuator of the invention, the DC electric motor can engage and rotate the axial shaft of speed-reducing mechanism through a mechanical linkage including but not limited to a belt pulley system, a gear train, or a clutch system. The DC electric motor can engage and rotate the axial shaft of speed-reducing mechanism through other devices well-known to those of ordinary skill in the art. These alternative devices include, but are not limited to frictional wheels, etc.

Microprocessor based control system is programmed to maintain the actuator bouncing forces at optimum values by regulating the DC electric motor voltage supply level. The optimum frequency for a baby bouncer system of the invention is from about 60 to about 100 times per minute (about 1 to about 1.7 Hz).

As illustrated in the flow chart of Figure 3, the microprocessor based control system is calibrated and regulates DC electric motor voltage supply as follows. A microprocessor based control system calibration switch is activated 100, tested 102, and the microprocessor based control system sets 104 the voltage supply V_n to the motor at a

defined value (initially V_{max} in this example) and the actuator is run 106 for a period of time "t". Detected motion sensor signal values F_n are recorded 108 during the period of time t. Voltage is tested 110 and if voltage does not equal minimum voltage V_{min} (e.g., 40% of V_{max}), V_n is adjusted 112 to V_{n+1} , where V_{n+1} equals $V_n - "v"$, where "v" is a
5 small voltage increment which in preferred embodiments ranges from 0.1 volt to 0.5 volt, most preferably about 0.2 volts, and the actuator is again run 106 for time period t and motion sensor signal values F_n are again recorded 108 during the period of time t. This procedure is repeated until V_{max} is determined, within an acceptable tolerance, to equal V_{min} .

10 In the example illustrated in Figure 3, V_n starts from a "high" voltage supply level (for example, about 90% of the maximum power supply voltage) and decreases incrementally to a "low" voltage supply level (for example, about 40% of maximum power supply voltage), wherein each increment of decreasing voltage level is about
- v. Alternatively, V_n starts from a "low" voltage supply level (for example, about 40%
15 of maximum power supply voltage) and is increased incrementally to a "high" voltage supply level (for example, about 90% of the maximum power supply voltage), wherein each increment of increasing voltage level is about +v.

In preferred embodiments, the maximum power supply voltage ranges from about 4.5 volts to about 9 volts, most preferably from about 6 volts to about 7.2 volts for battery
20 operation.

In preferred embodiments, the calibration running time t for each V_n ranges from about 5 seconds to about 30 seconds, preferably from about 10 to about 15 seconds.

In the embodiment of the invention illustrated in Figure 3, after V_n is tested 110 and determined 114 to equal V_{min} , the microprocessor based control system:

25 (1) compares recorded F_n values and determines the maximum F_{max} value; and
(2) selects and stores 116 the voltage (V of F_{max}) which generated the F_{max} value. The microprocessor based control system sets 118 the voltage supply level of the DC electric motor to V of F_{max} value and if testing 102 of the microprocessor based control system calibration switch indicates that the switch is not activated, the DC motor continues to
30 run 120 at V of F_{max} until the microprocessor based control system is switched off or a pre-set operation time has expired.

Microprocessor based control system 11 of Figure 2 includes a microprocessor which comprises at least one conventional analog-to-digital card, at least one conventional input-output card, and a predetermined voltage supply, which may be set at a convenient voltage such as 6 volts. Figure 5 illustrates a block diagram of one
5 embodiment of a microprocessor- based electrical control system which can be used in the instant invention.

Referring to Figure 5, one embodiment of a microprocessor- based electrical control system used in the invention comprises the following components connected through system bus circuitry 74: batteries 50, AC/DC adaptor 52, switch 72, motion
10 sensor 54, microprocessor 56, voice and recording integrated circuit (IC) 58, motor drive power transistor amplification circuit 60 connected to DC motor 68 or voltage regulator 62 connected to DC motor 68, microphone 64, and speaker 66. It will be understood that Figure 5 is quite simplified. For example, the details of each of circuit portions of microprocessor 56 and voice and recording IC 58 are not shown because they are
15 individually well known to those skilled in the art. Further, although not shown separately in Figure 5, input/output (I/O) pins can be included in the microprocessor- based electrical control system for use in making connections to external circuitry. For example, such I/O pins may be connected more or less directly to system bus 74, or I/O pins may be provided as part of external signaling circuitry.

Microprocessor based control systems used in actuators of the invention may also
20 contain voice recording and playback IC which create, through known designs, various soothing sounds (including music, sea wave sound, or a parent's voice message recording). The voice recording and playback IC based control system may be programmed to record sound through a microphone and to emit such sounds through a
25 transducer (such as transducer 9 of Figure 2) at time intervals which are coordinated with the bouncing of the actuator. This embodiment of the invention provides a complementary combination of soothing bouncing movement and sound.

For example, a voice recording and playback IC such as the
Winbond ISD5108 ChipCorder could be included in a microprocessor based control
30 system and could be programmed with soothing sounds such as a melody or sea wave

sound; the microprocessor based control system could also allow parents to record their own voices messages through the microphone as well.

A wide range of microprocessors can be used in actuators of the invention; these include but are not limited to the 8051 microprocessor made by Texas Instruments.

5 Referring again to Figure 2, when eccentric weight 29 rotates and swings in a pendulum-like rotational movement, it generates a centrifugal force in a direction away from the center of its rotating axis. This force will pull down or push up a bouncer seat (not shown) when eccentric weight 29 rotates to its lowest and highest positions, respectively. Since the centrifugal force is always directed in a radial outward direction,
10 when eccentric weight 29 swings to positions other than a vertical position, a horizontal force component is generated. When the actuator is mounted on a baby bouncer frame, the friction between the bouncer frame foot pads and supporting surface will balance the horizontal component of the centrifugal force.

More than one eccentric weight can be used in actuators of the instant invention.
15 For example, in the twin eccentric weight force diagram illustrated in Figure 4, two identical eccentric weights rotate and swing in pendulum-like rotational movements in opposite directions and are linked by a synchronized speed reduction mechanism. The twin eccentric weights illustrated in Figure 4 are “mirror images” of one another along their center vertical axis. Thus, the horizontal components of their centrifugal forces will
20 be balanced and result in a zero horizontal resultant force, while the vertical force components, which actuate the vertical bouncing motion, are not affected.

More specifically, Figure 4 illustrates a diagram of the forces associated with the movement of rotatable eccentric weights A and B axially-mounted through rotational linkage 45 to a speed reduction mechanism (such as speed reduction mechanism 23 of
25 Figure 2) in one embodiment of an actuator of the instant invention. The synchronized, opposite rotations of weights A and B illustrated in Figure 4 generate additive downward forces A1 and B1 and additive upward forces A3 and B3. The synchronized, opposite rotations of weights A and B illustrated in Figure 4 also generate canceling horizontal forces A2 and B2. As shown in Figure 4, the synchronized, opposite rotations of weights
30 A and B also generate centrifugal forces that contribute to baby bouncer system bouncing.

A preferred embodiment of a baby bouncer system of the invention supports a baby that weighs from about 6 to about 24 pounds, bounces the baby at a baby bouncer system frequency of about 1 to 2 Hz, and comprises a baby bouncer seat which is connected to an actuator of the invention wherein: the actuator is comprised of two
5 eccentric weights which each weigh about 50 grams to about 300 grams; and (2) the eccentric weights each have an eccentricity radius "Recc" which ranges from about 10 millimeters to about 60 millimeters as the weights swing in a pendulum-like movement when coaxially mounted on the shaft of a speed-reducing mechanism which rotates at a speed of from about 50 to about 100 revolutions per minute.

10

What is claimed is:

1. An actuator comprising:

- (a) a housing adapted to engage a baby bouncer system for transmission of bouncing forces;
- (b) a motion sensor which can generate signals corresponding to baby bouncer system bouncing force and which is enclosed within and supported by the housing;
- (c) a microprocessor based control system which can detect and store the motion sensor signals and which is enclosed within and supported by the housing;
- (d) a DC electric motor which (i) is connectable to a power source, (ii) is in electrical communication with the microprocessor based control system, (iii) during operation receives a supply voltage at a level which is regulated by the microprocessor based control system, and (iv) is enclosed within and supported by the housing;
- (e) a speed reduction mechanism which comprises an axial shaft connected for rotation to and driven by the DC electric motor and which is enclosed within and supported by the housing;
- (f) a rotatable eccentric weight which is mounted coaxially on the speed reduction mechanism axial shaft for rotational and pendulum-like motion and which is enclosed within and supported by the housing; wherein the microprocessor based control system is calibrated to maintain the DC electric motor supply voltage level at a value which is optimized to maintain baby bouncer system bouncing at soothing frequencies.

2. An actuator of claim 1, wherein the speed reduction ratio of the speed reduction mechanism is set such that the rotational speed of the actuator's eccentric weight is from about 50 to about 100 times per minute at a microprocessor-controlled DC motor supply voltage range of about 40% to about 90% of the maximum DC motor supply voltage, and the soothing frequency is the baby bouncer system resonant frequency when supporting a baby.

3. An actuator of claim 1, wherein the microprocessor based control system is calibrated and regulates DC electric motor voltage supply by a method comprising:
 - (a) retrieving a value corresponding to the maximum DC electric motor supply voltage level (V_{max}) and setting DC electric motor supply voltage level V_n initially at V_{max} ;
 - (b) selecting an actuator operation time interval t ;
 - (c) operating the actuator for time interval t at V_n and detecting and recording motion sensor signal values F_n during time interval t ;
 - (d) retrieving a value corresponding to the minimum DC electric motor supply voltage level (V_{min}), detecting V_n , and, if V_n does not equal V_{min} within an acceptable tolerance, adjusting V_n by subtracting voltage increment v ;
 - (e) repeating steps (c) and (d) until V_n equals V_{min} within an acceptable tolerance;
 - (f) comparing F_n values recorded at each V_n and determining the maximum F_n value (F_{max}) and the V_n corresponding to F_{max} (V of F_{max}); and
 - (g) setting DC electric motor voltage supply at V of F_{max} .
4. An actuator of claim 1, wherein the microprocessor based control system is calibrated and regulates DC electric motor voltage supply by a method comprising:
 - (a) retrieving a value corresponding to the maximum DC electric motor supply voltage level (V_{min}) and setting DC electric motor supply voltage level V_n initially at V_{min} ;
 - (b) selecting an actuator operation time interval t ;
 - (c) operating the actuator for time interval t at V_n and detecting and recording motion sensor signal values F_n during time interval t ;
 - (d) retrieving a value corresponding to the maximum DC electric motor supply voltage level (V_{max}), detecting V_n , and, if V_n does not equal V_{max} within an acceptable tolerance, adjusting V_n by adding voltage increment v ;
 - (e) repeating steps (c) and (d) until V_n equals V_{max} within an acceptable tolerance;
 - (f) comparing F_n values recorded at each V_n and determining the maximum F_n value (F_{max}) and the V_n corresponding to F_{max} (V of F_{max}); and
 - (g) setting DC electric motor voltage supply at V of F_{max} .
5. An actuator of claim 3, wherein V_{max} is about 90% of the maximum power supply voltage and V_{min} is about 40% of the maximum power supply voltage.

6. An actuator of claim 4, wherein V_{max} is about 90% of the maximum power supply voltage and V_{min} is about 40% of the maximum power supply voltage.
7. An actuator of claim 3, wherein v is ranges from about 0.1 volts to about 0.5 volts.
8. An actuator of claim 4, wherein v is ranges from about 0.1 volts to about 0.5 volts.
9. An actuator of claim 3, wherein the maximum power supply voltage ranges from about 4.5 volts to about 9 volts.
10. An actuator of claim 4, wherein the maximum power supply voltage ranges from about 4.5 volts to about 9 volts.
11. An actuator of claim 3, wherein t ranges from about 5 seconds to about 30 seconds.
12. An actuator of claim 4, wherein t ranges from about 5 seconds to about 30 seconds.
13. An actuator of claim 1, wherein during operation the actuator bounces the baby bouncer system at a frequency of around 60 to around 100 times per minute.
14. An actuator of claim 3, wherein during operation the actuator bounces the baby bouncer system at a frequency of around 60 to around 100 times per minute.
15. An actuator of claim 4, wherein during operation the actuator bounces the baby bouncer system at a frequency of around 60 to around 100 times per minute.
16. An actuator of claim 3, wherein during operation the actuator bounces the baby bouncer system at the system resonant frequency.
17. An actuator of claim 4, wherein during operation the actuator bounces the baby bouncer system at the system resonant frequency.
18. An actuator of claim 1, wherein the eccentric weight rotates from about 50 to about 100 times per minute at DC electric motor supply voltage levels of about 40% to about 90% of the maximum DC electric motor supply voltage.
19. An actuator of claim 1, wherein the microprocessor based control system is programmed to broadcast soothing sounds.
20. An actuator of claim 1, wherein the microprocessor based control system is programmed to broadcast a prerecorded message.

21. An actuator of claim 1, wherein the actuator further comprises a battery pack which powers the DC electric motor.
22. An actuator of claim 1, wherein the voltage-regulated DC electric motor is powered by electrical connection to an electrical wall outlet.
23. An actuator of claim 1, wherein the voltage-regulated DC electric motor is powered by electrical connection to a remote battery pack or generator.
24. An actuator of claim 1, wherein the DC electric motor voltage supply is regulated by either a pulse-width modulator (PWM) or linear voltage regulator under the control of the microprocessor based control system.
25. An actuator of claim 1, wherein the actuator comprises two rotatable eccentric weights which:
 - (a) are mounted on the speed reduction mechanism coaxially with the speed reduction mechanism shaft for rotational, pendulum-like motion, and
 - (b) are enclosed within and supported by the housing.
26. An actuator of claim 1, wherein:
 - (a) the actuator is comprised of two eccentric weights which each weigh about 25 grams to about 500 grams; and
 - (b) the eccentric weights each have an eccentricity radius which ranges from about 10 millimeters to about 100 millimeters when the speed-reducing mechanism shaft rotates at a speed of from about 25 to about 150 revolutions per minute.
27. An actuator of claim 1, wherein the maximum voltage supplied to the DC electric motor ranges from about 3 volts to about 30 volts.
28. An actuator of claim 1, wherein the DC electric motor engages and rotates the axial shaft of speed-reducing mechanism through a mechanical linkage.
29. An actuator of claim 12, wherein the mechanical linkage is a belt pulley system, a gear train, a clutch system, or frictional wheels.

30. A baby bouncer system comprising:
- (a) a resilient support frame adapted for positioning on a relatively level surface;
 - (b) a cradle-like bed which can be attached to and supported by the frame in an elevated position suitable for stable support of a baby; and
 - (c) an actuator of claim 1, wherein the actuator housing can be mounted for transmission of bouncing force on the resilient support frame.
31. A baby bouncer system comprising:
- (a) a resilient support frame adapted for positioning on a relatively level surface;
 - (b) a cradle-like bed attached to and supported by the frame in an elevated position suitable for stable support of a baby; and
 - (c) an actuator of claim 1, wherein the actuator housing is mounted for transmission of bouncing force on the resilient support frame.
32. A baby bouncer system comprising:
- (a) a resilient support frame adapted for positioning on a relatively level surface;
 - (b) a cradle-like bed attached to and supported by the frame in an elevated position suitable for stable support of a baby; and
 - (c) an actuator of claim 3, wherein the actuator housing is mounted for transmission of bouncing force on the resilient support frame.
33. A baby bouncer system comprising:
- (a) a resilient support frame adapted for positioning on a relatively level surface;
 - (b) a cradle-like bed attached to and supported by the frame in an elevated position suitable for stable support of a baby; and
 - (c) an actuator of claim 4, wherein the actuator housing is mounted for transmission of bouncing force on the resilient support frame.

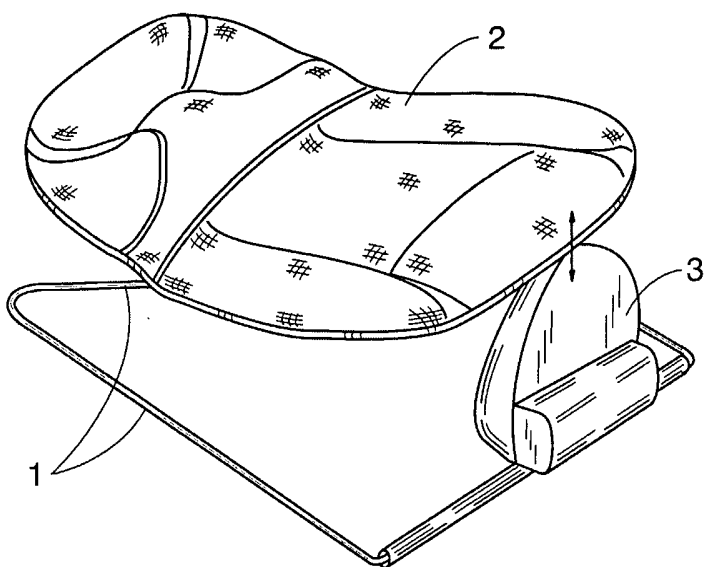

FIG. 1

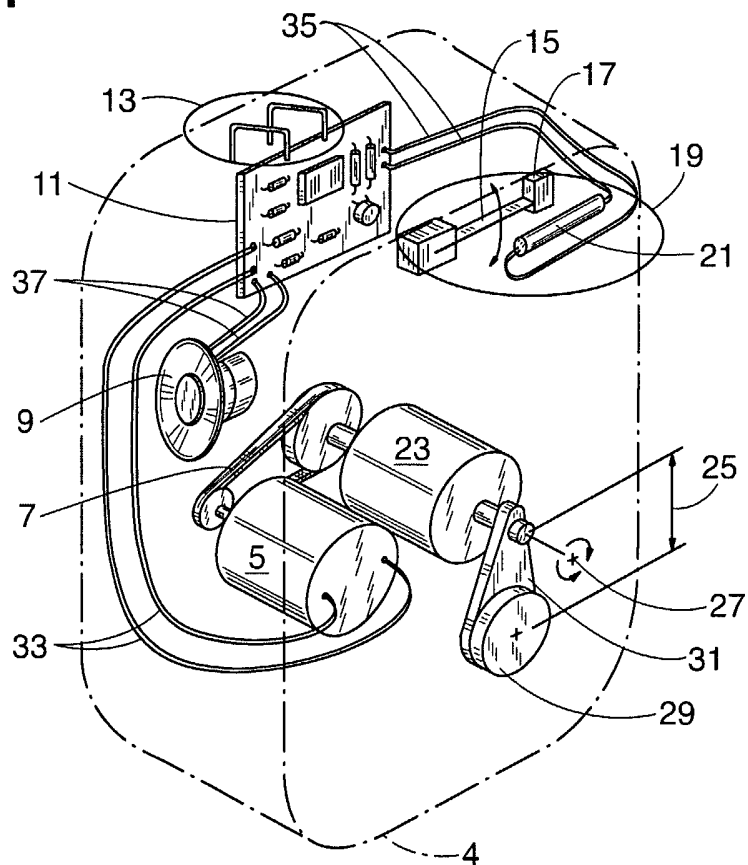

FIG. 2

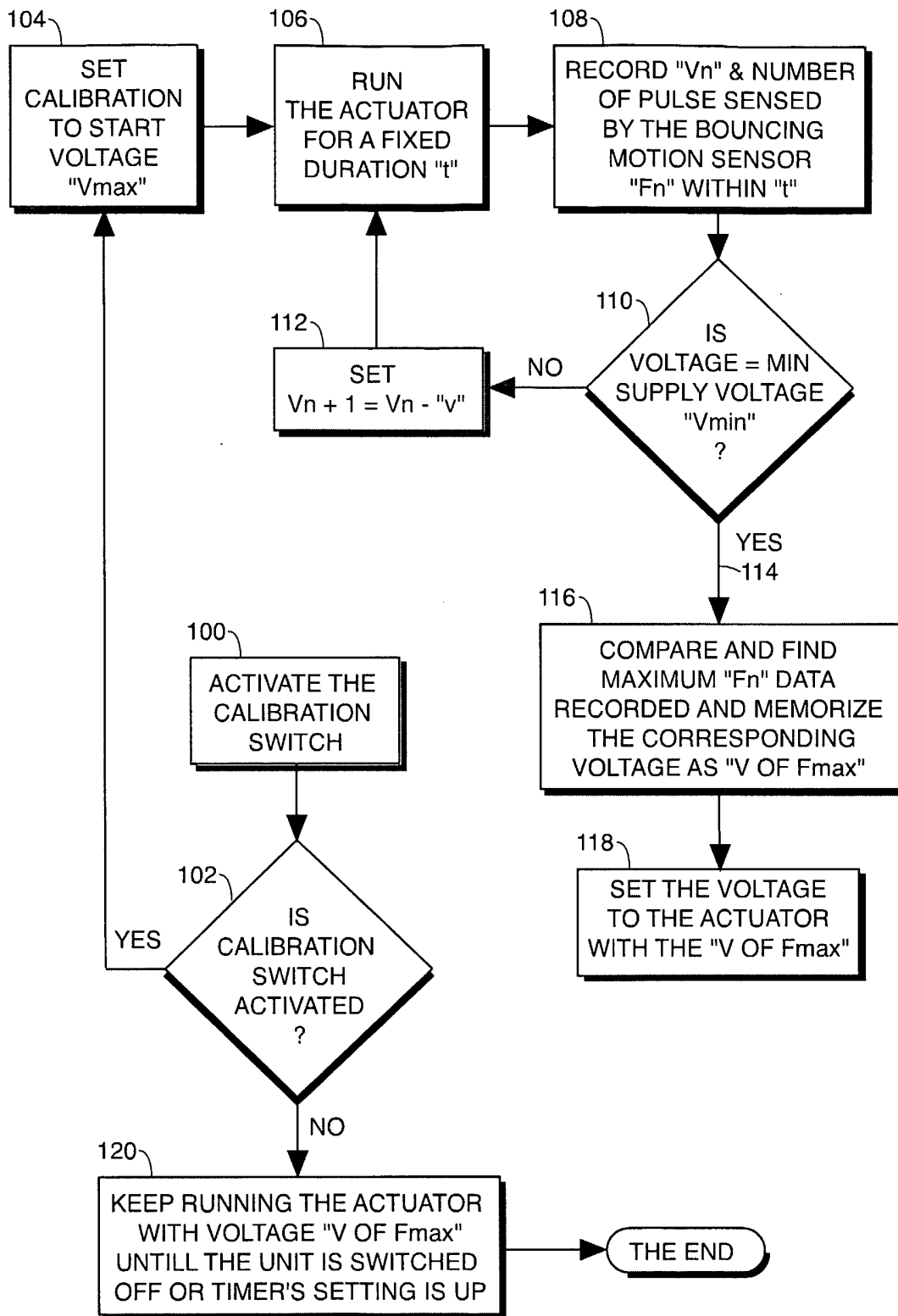

FIG. 3

CENTRIFUGAL FORCES OF BOTH ECCENTRIC WEIGHTS

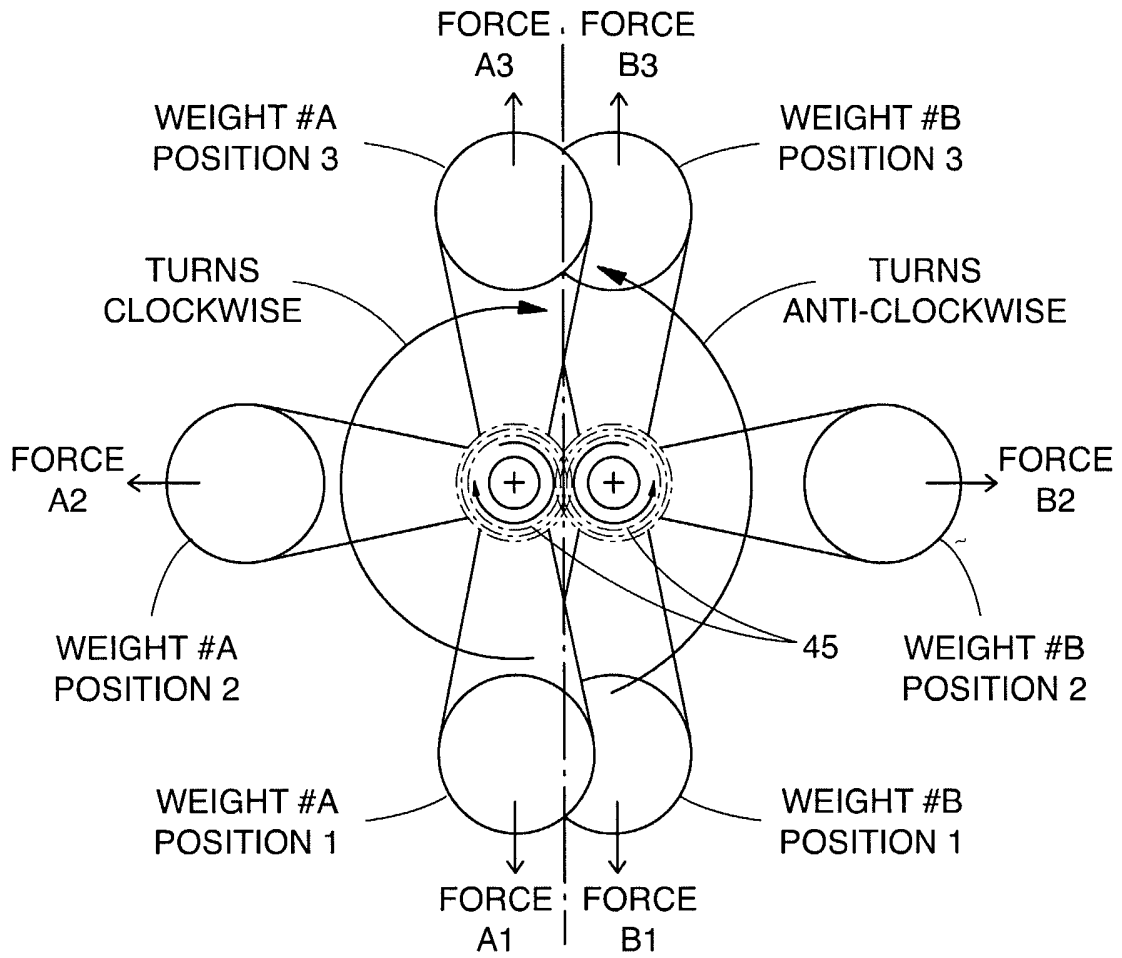
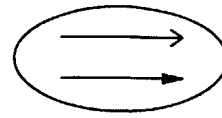

FIG. 4

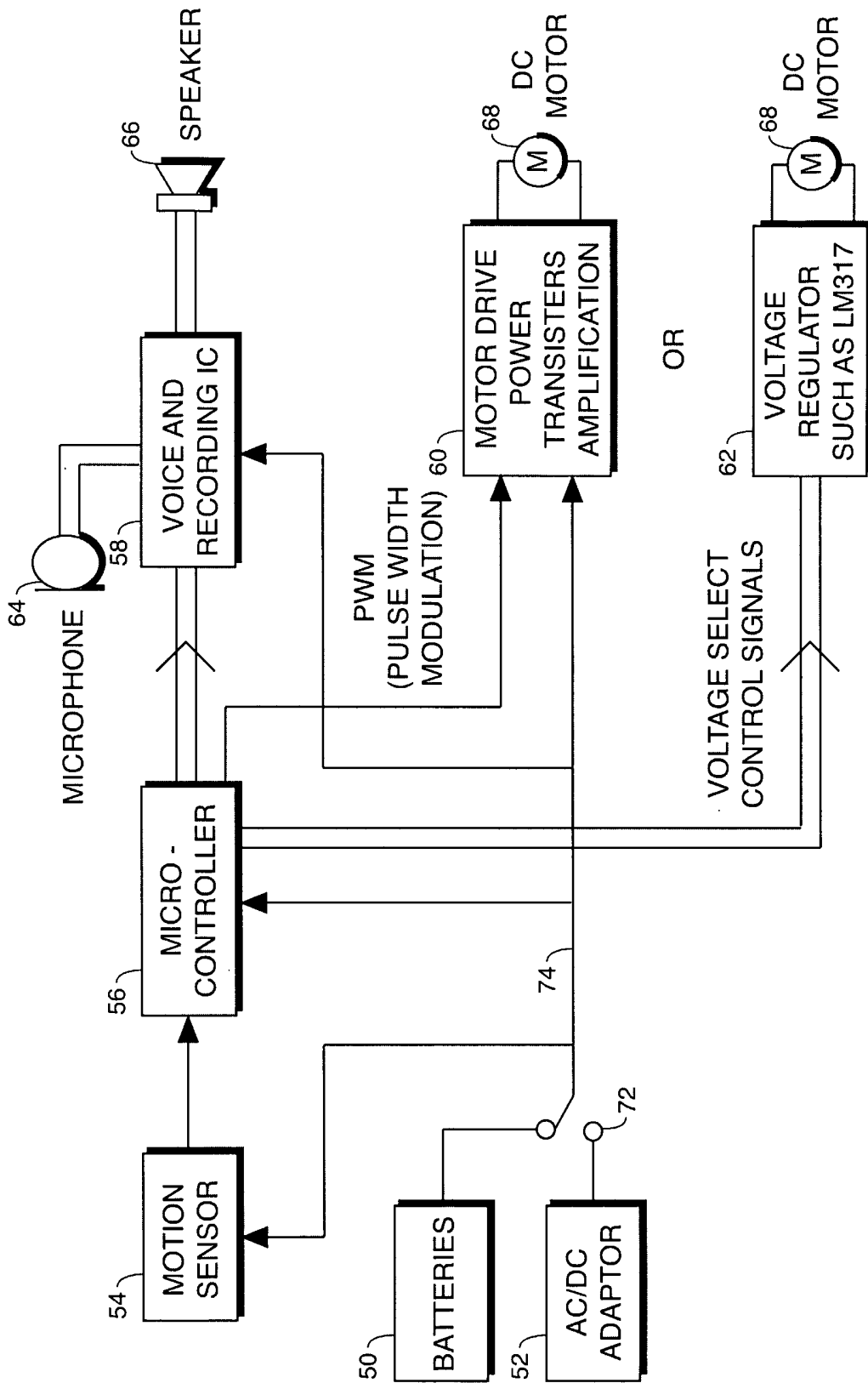

FIG. 5

INTERNATIONAL SEARCH REPORT

IB2004/002142

A. CLASSIFICATION OF SUBJECT MATTER
 IPC 7 A47D13/10 A47D9/02 A47D9/04

According to International Patent Classification (IPC) or to both national classification and IPC

B. FIELDS SEARCHED

Minimum documentation searched (classification system followed by classification symbols)
 IPC 7 A47D B62B

Documentation searched other than minimum documentation to the extent that such documents are included in the fields searched

Electronic data base consulted during the international search (name of data base and, where practical, search terms used)

EPO-Internal

C. DOCUMENTS CONSIDERED TO BE RELEVANT

Category °	Citation of document, with indication, where appropriate, of the relevant passages	Relevant to claim No.
X	WO 98/17155 A (LOCUS TECHNOLOGY LIMITED) 30 April 1998 (1998-04-30) page 6, last line - page 7, line 2	1, 17, 21, 30, 31
X	EP 0 250 263 A (BERKOVICH SHLOMO) 23 December 1987 (1987-12-23) column 4, lines 31-36	1
X	DE 197 13 293 A (KOLLER ROMAN) 14 May 1998 (1998-05-14) the whole document	1
X	WO 98/17150 A (INFANT ADVANTAGE INC) 30 April 1998 (1998-04-30) the whole document	1
	----- -/--	

Further documents are listed in the continuation of box C.

Patent family members are listed in annex.

° Special categories of cited documents :

- *A* document defining the general state of the art which is not considered to be of particular relevance
- *E* earlier document but published on or after the international filing date
- *L* document which may throw doubts on priority claim(s) or which is cited to establish the publication date of another citation or other special reason (as specified)
- *O* document referring to an oral disclosure, use, exhibition or other means
- *P* document published prior to the international filing date but later than the priority date claimed

- *T* later document published after the international filing date or priority date and not in conflict with the application but cited to understand the principle or theory underlying the invention
- *X* document of particular relevance; the claimed invention cannot be considered novel or cannot be considered to involve an inventive step when the document is taken alone
- *Y* document of particular relevance; the claimed invention cannot be considered to involve an inventive step when the document is combined with one or more other such documents, such combination being obvious to a person skilled in the art.
- *Z* document member of the same patent family

Date of the actual completion of the international search

12 October 2004

Date of mailing of the international search report

22/10/2004

Name and mailing address of the ISA

European Patent Office, P.B. 5818 Patentlaan 2
 NL - 2280 HV Rijswijk
 Tel. (+31-70) 340-2040, Tx. 31 651 epo nl,
 Fax: (+31-70) 340-3016

Authorized officer

Reichhardt, O

INTERNATIONAL SEARCH REPORT

IB2004/002142

C.(Continuation) DOCUMENTS CONSIDERED TO BE RELEVANT

Category °	Citation of document, with indication, where appropriate, of the relevant passages	Relevant to claim No.
Y	US 6 378 940 B1 (LONGORIA JOSE P ET AL) 30 April 2002 (2002-04-30) the whole document -----	1
Y	US 6 431 646 B1 (LONGORIA JOSE P) 13 August 2002 (2002-08-13) the whole document -----	1

INTERNATIONAL SEARCH REPORT

IB2004/002142

Patent document cited in search report		Publication date	Patent family member(s)	Publication date
WO 9817155	A	30-04-1998	AU 4713997 A WO 9817155 A1	15-05-1998 30-04-1998
EP 0250263	A	23-12-1987	AT 66651 T DE 3772463 D1 EP 0250263 A2 ES 2026538 T3 JP 63078873 A US 4856130 A	15-09-1991 02-10-1991 23-12-1987 01-05-1992 08-04-1988 15-08-1989
DE 19713293	A	14-05-1998	DE 19713293 A1	14-05-1998
WO 9817150	A	30-04-1998	AU 5085498 A BR 9712418 A CA 2269291 A1 EP 1006844 A2 JP 2000510022 T KR 2000052699 A WO 9817150 A2	15-05-1998 11-07-2000 30-04-1998 14-06-2000 08-08-2000 25-08-2000 30-04-1998
US 6378940	B1	30-04-2002	GB 2355923 A , B US 6431646 B1	09-05-2001 13-08-2002
US 6431646	B1	13-08-2002	US 6378940 B1 GB 2355923 A , B	30-04-2002 09-05-2001