



US 20050205081A1

(19) **United States**

(12) **Patent Application Publication**

**Barker, JR. et al.**

(10) **Pub. No.: US 2005/0205081 A1**

(43) **Pub. Date: Sep. 22, 2005**

(54) **DRAWER FOR A HEATED FOOD CABINET**

(57) **ABSTRACT**

(75) Inventors: **Richard F. Barker JR.**, Euless, TX (US); **Charles J. Kingdon**, Flower Mound, TX (US); **Christopher J. Adelman**, Coppell, TX (US)

Correspondence Address:  
**SANFORD E. WARREN, JR.**  
**P.O. BOX 50784**  
**DALLAS, TX 75201 (US)**

(73) Assignee: **American Permanent Ware Corporation**, Dallas, TX

(21) Appl. No.: **10/803,489**

(22) Filed: **Mar. 18, 2004**

**Publication Classification**

(51) **Int. Cl.<sup>7</sup>** ..... **F23M 7/00; F24C 15/04**  
(52) **U.S. Cl.** ..... **126/190**

The food warmer oven includes a cabinet 12 having opposing side walls 16, 18, a top wall 20, a bottom wall 22, a back wall 24, and a front wall 26 defining a heating cavity 28, the front wall 26 defining an opening 30 into the heating cavity 28; a heating source 32 disposed within the heating cavity 28; a drawer frame 38 having a pair of opposing side rails 44, 46, each of the side rails having a front end 48 and a terminal end 50, the side rails being functionally connected with the side walls 16, 18 of the cabinet in a manner such that the drawer frame 38 can be moved between an open position wherein the drawer frame 38 extends substantially exterior of the heating cavity 28 through the opening 30 and a closed position wherein the drawer frame 38 is positioned substantially within the heating cavity 28, the front end 48 of the side rails 44, 46 being positioned proximate the front wall 26 and the terminal end 50 being positioned proximate the back wall 24 when the drawer frame 38 is in the closed position; a food tray 42 removably held by the drawer frame 38; a door 40 is moveably connected to the side rails 44, 46 of the drawer frame, the door 40 moveable between an open position and a closed position; and a locking mechanism in connection between the door 40 and the side rails 44, 46 of the drawer frame 38 for selectively maintaining the door 40 in the closed position.

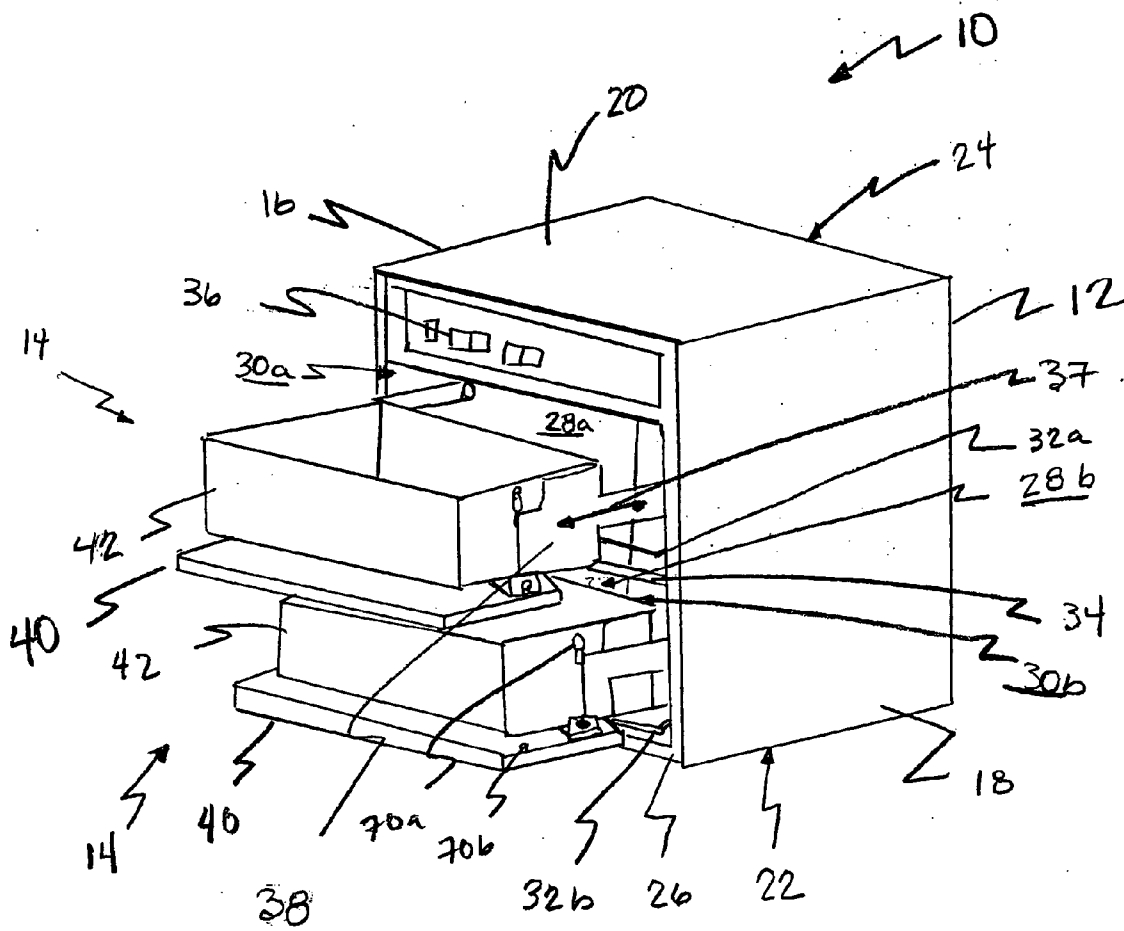

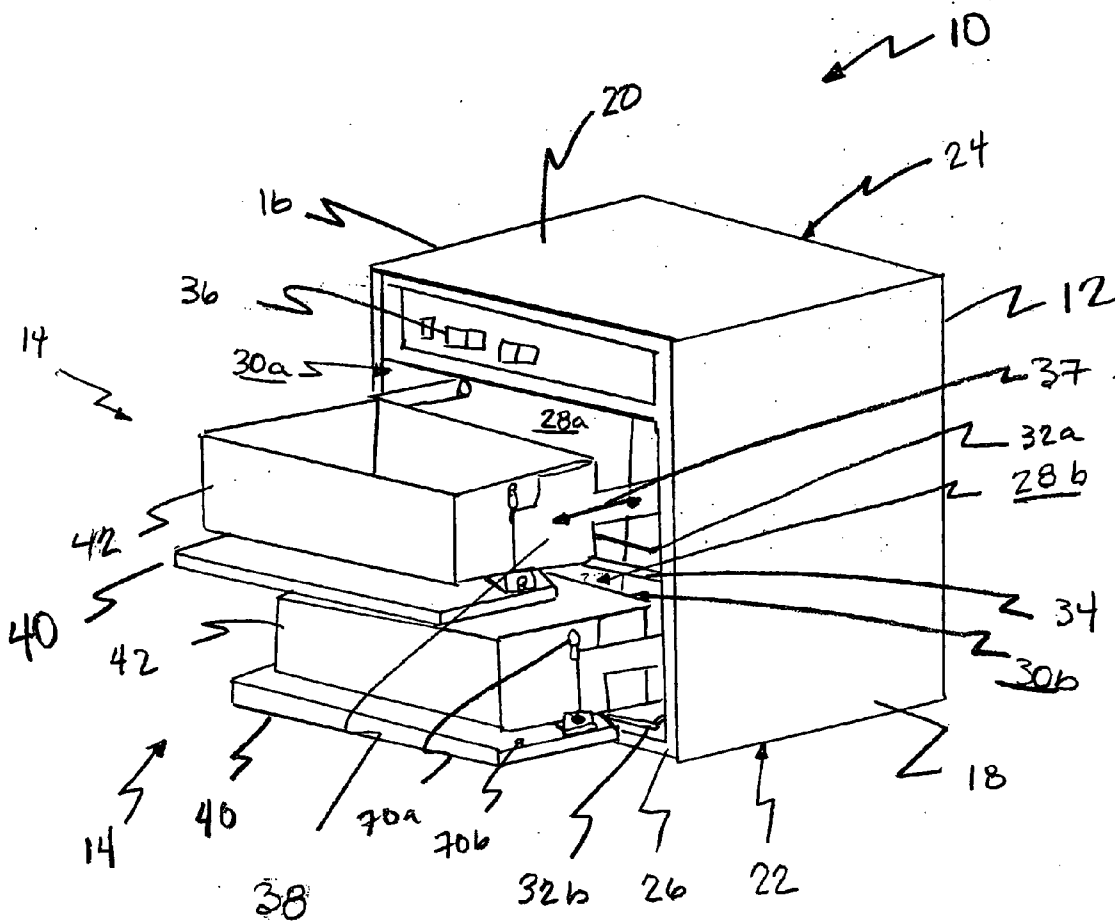

Figure 1

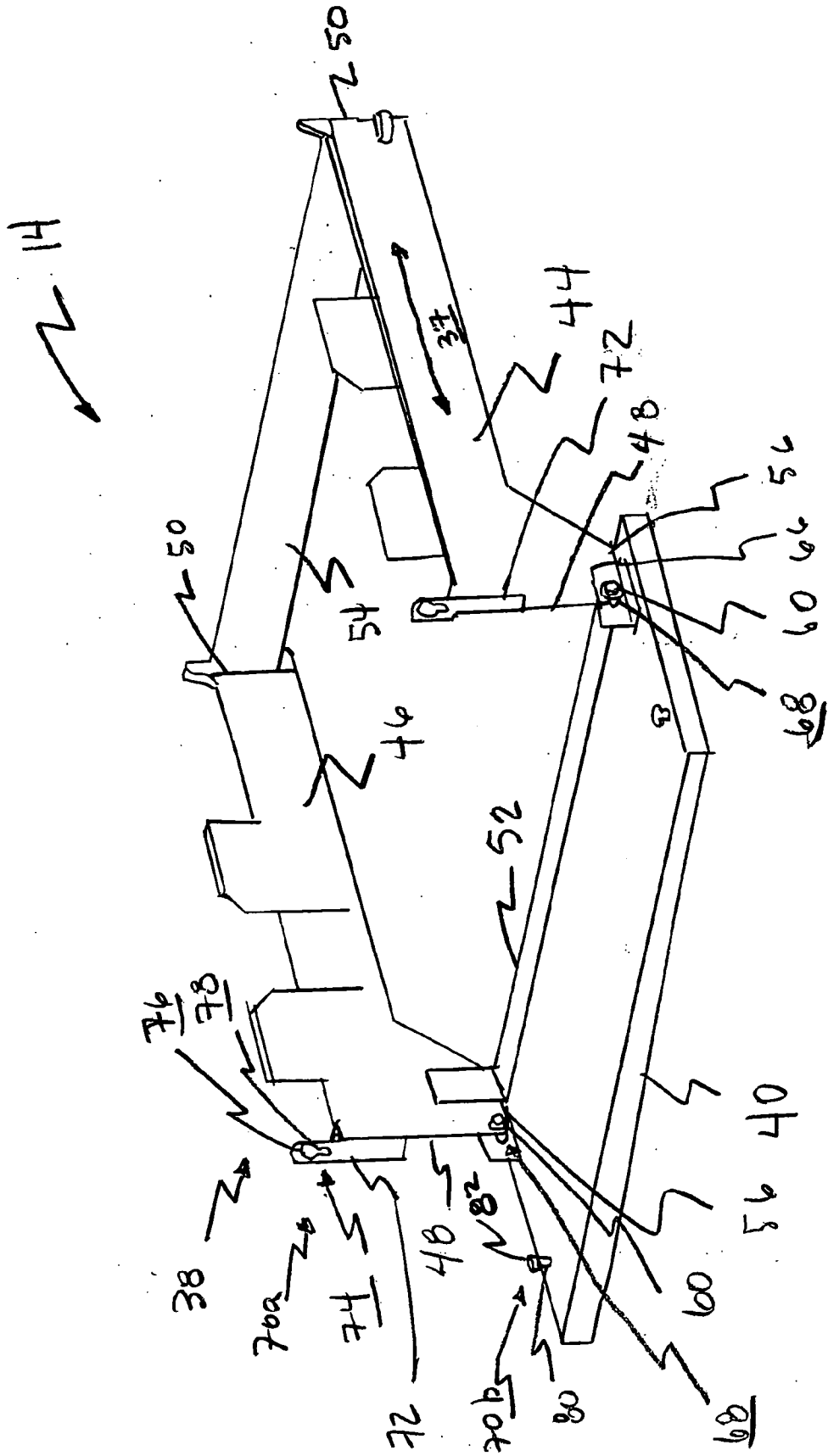

Figure 2

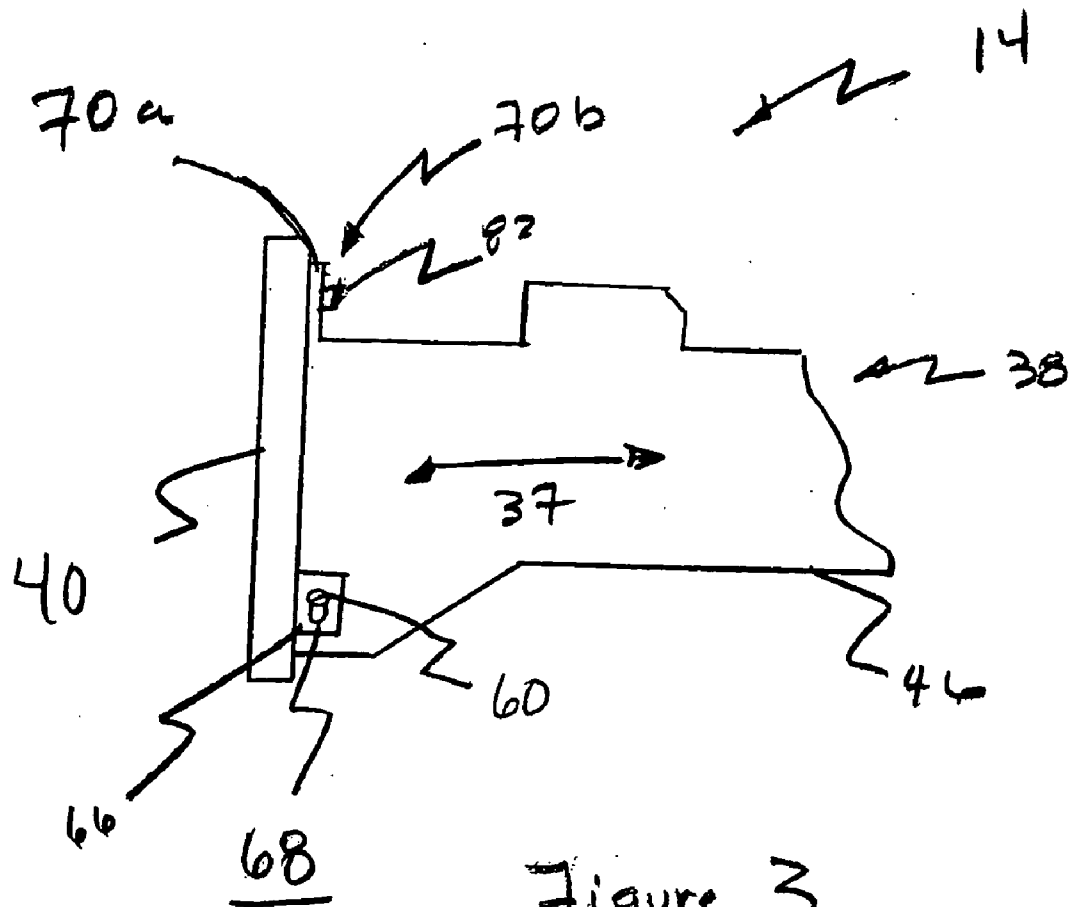

Figure 3

**DRAWER FOR A HEATED FOOD CABINET****FIELD OF THE INVENTION**

[0001] The present invention relates in general to a heated food cabinet and more particularly, but not limited to, a heated food cabinet that includes a moveable food drawer that has a positional drawer door.

**BACKGROUND**

[0002] Food warming devices, are often used in commercial establishments for maintaining prepared foods at a serving temperature. These cabinets are also used to reheat food products and for storage of food products that require extensive preparation time.

[0003] These food warming cabinets include one or more drawers that are positional within a heated cavity. The drawers include a storage area for the food that may be either a permanent part of the drawer or a removable tray or pan. In either situation the food product must be placed in and removed from the storage area, and the storage area must be regularly sanitized.

[0004] In the prior art devices having a permanent food storage container as part of the drawer increases the effort and time required to clean and sanitize the food storage area. First, it is necessary to shut down the heating element for safety reasons resulting in taking the food cabinet out of service, not only for the cleaning process but also during the period of time for the heating cavity to cool and then for the period of time for the heating cavity to again attain the desired temperature. Further, to achieve adequate cleaning the entire drawer must be removed from the food cabinet wasting time and often resulting in damage to the drawer and/or the food cabinet.

[0005] Some prior art food warming cabinets include drawers that have a removable food storage container. These devices allow a user to exchange food containers within the drawer and permit easier cleaning of the food container. However, these prior art devices require that a user precariously grip the food container when placing the container into the drawer or removing the container from the drawer. The limited access and ability to grip the food container is due to the required minimal foot print of the food cabinet and the utilization of a minimal heated cavity. This limited ability to handle the food container often results in accidents wherein the food container is dropped or mishandled resulting in injury to the user or others in the vicinity, damage to the food cabinet, and loss of food product.

[0006] It is thus a desire of the present invention to provide a positional drawer door for a food cabinet that address shortcomings of the prior art food cabinets. It is a still further desire of the present invention to provide a positional drawer that facilitates access to a drawer food container without sacrificing size limitations or the capacity of the food cabinet. It is a still further desire of the present invention to provide a positional drawer door that facilitates quick access for removing or placing a food container in a food cabinet limiting the loss of heat from the heated cavity, conserving energy, and preventing unnecessary heating of the heat source that may overcook the contained food product.

**SUMMARY OF THE INVENTION**

[0007] In view of the foregoing and other considerations, the present invention relates to food warming cabinets and more particularly a positional drawer door for a food cabinet.

[0008] It is a benefit of the present invention to provide positional drawer door that is movable between an open position to a closed and locked position.

[0009] It is a further benefit of the present invention to provide a positional drawer door that facilitates full access to a food tray for inserting the food tray into the drawer or removing the food tray from the drawer.

[0010] Accordingly, a positional drawer door for a food warming oven is provided. The positional drawer door is connected to the side rails of a drawer frame in a manner to be moved from a closed position to an open position. The drawer frame may be adapted to removably carry a food tray. The positional drawer door is selectively maintained in the closed position by a locking mechanism connectable between the positional door and the side rails of the drawer frame.

[0011] A food warmer oven is further provided, the food warmer oven includes a cabinet having opposing side walls, a top wall, a bottom wall, a back wall, and a front wall defining a heating cavity, the front wall defining an opening into the heating cavity; a heating source disposed within the heating cavity; a drawer frame having a pair of opposing side rails, each of the side rails having a front end and a terminal end, the side rails being functionally connected with the side walls of the cabinet in a manner such that the drawer frame can be moved between an open position wherein the drawer frame extends substantially exterior of the heating cavity through the opening and a closed position wherein the drawer frame is positioned substantially within the heating cavity, the front end of the side rails being positioned proximate the front wall and the terminal end being positioned proximate the back wall when the drawer frame is in the closed position; a food tray removably held by the drawer frame; a door moveably connected to the side rails of the drawer frame, the door moveable between an open position and a closed position; and a locking mechanism in connection between the door and the side rails of the drawer frame for selectively maintaining the door in the closed position.

[0012] A method of maintaining a temperature of a food product including the steps of providing a food warmer oven comprising: a cabinet having opposing side walls, a top wall, a bottom wall, a back wall, and a front wall defining a heating cavity, the front wall defining an opening into the heating cavity, a heating source disposed within the heating cavity, a drawer frame having a pair of opposing side rails, each of the side rails having a front end and a terminal end, the side rails being functionally connected with the side walls of the cabinet in a manner such that the drawer frame can be moved between an open position wherein the drawer frame extends substantially exterior of the heating cavity through the opening and a closed position wherein the drawer frame is positioned substantially within the heating cavity, the front end of the side rails being positioned proximate the front wall and the terminal end being positioned proximate the back wall when the drawer frame is in

the closed position, a door moveably connected to the side rails of the drawer frame, the door moveable between an open position and a closed position, and a locking mechanism in connection between the door and the side rails of the drawer frame for selectively maintaining the door in the closed position; providing a desired temperature within the heating cavity; pulling the door and drawer frame substantially through the front wall opening from the heating cavity; manipulating the door to disconnect the door from the drawer frame via the locking mechanism; moving the door to the open position; removing a food tray from the drawer frame; placing a food tray in the drawer frame; moving the door to the closed position; and manipulating the door to secure the door to the door frame via the locking mechanism.

[0013] The foregoing has outlined the features and technical advantages of the present invention in order that the detailed description of the invention that follows may be better understood. Additional features and advantages of the invention will be described hereinafter which form the subject of the claims of the invention.

#### BRIEF DESCRIPTION OF THE DRAWINGS

[0014] The foregoing and other features and aspects of the present invention will be best understood with reference to the following detailed description of a specific embodiment of the invention, when read in conjunction with the accompanying drawings, wherein:

[0015] FIG. 1 is a perspective view of a positional drawer door for a food cabinet of the present invention;

[0016] FIG. 2 is a perspective view of a positional drawer door of the present invention shown in the open position; and

[0017] FIG. 3 is a perspective side view of an embodiment of the present invention with the positional drawer door in the closed position.

#### DETAILED DESCRIPTION

[0018] Refer now to the drawings wherein depicted elements are not necessarily shown to scale and wherein like or similar elements are designated by the same reference numeral through the several views.

[0019] FIG. 1 is a perspective view of a positional drawer door for a food cabinet of the present invention generally designated by the numeral 10. The present invention includes a food cabinet 12 and a drawer, generally designated by the numeral 14, that is movable between a closed position in which drawer 14 is positioned within food cabinet 12 and an opened position wherein drawer 14 extends from cabinet 12.

[0020] Cabinet 12 may be a cooking or warming oven or holding oven. Cabinet 12 includes opposing side walls 16, 18, a top wall 20, a bottom wall 22, a back wall 24, and a front wall 26 forming a heated cavity 28. Cabinet 12 may be constructed of stainless steel, aluminum or other suitable material for a heating apparatus.

[0021] Access to heated cavity 28 is formed by openings 30 created through or defined by front wall 26. Cavity 28 is heated by a heat source 32 that may include any known heat source for cooking and/or warming food products. As shown

in FIG. 1, heat source 32 is an electrically charged conductive heat source. Heat source 32 may be manipulated by controls 36.

[0022] Cavity 28 may be a single, continuous cavity or comprise separate cavities as illustrated in FIG. 1. As shown in FIG. 1, heated cavity 28 is divided into two separate heated cavities 28a and 28b. The cavities 28a and 28b are separated by a partition 34 positioned within cavity 28 and extending to front wall 26 to form a portion of front wall 26. Each heated cavity section 28a, 28b may be heated individually by respective, separate heat sources 32a, 32b disposed within each heated cavity section 28a, 28b. It may be further desired that each heat each heat source 32a, 32b be individually temperature controlled by controls 36. The cavity sections 28a, 28b may be heated by a single heat source 32.

[0023] Drawer 14 is slidably inserted into cavity 28 through an opening 30 formed by front wall 26 (which may include a partition 34) of cabinet 12. Drawer 14 includes a drawer frame 38 that is described in detail in relation to FIG. 2. Drawer frame 38 is moveably connected to cabinet 12 so as to allow drawer frame 38 to be moveable from a closed position, wherein drawer frame 38 is positioned within heated cavity 28, to an open position wherein drawer frame 38 extends from cabinet 12 and heated cavity 28. Opening 30 is sized so that when drawer 14 is inserted into cavity 28 and positional drawer door 40 is in the closed position, opening 30 is substantially sealed.

[0024] Drawer 14 includes a positional door 40 connected to drawer frame 38. Positional drawer door 40 may be moved from a closed position (not shown) to an open position. In the closed position, positional drawer door 40 is locked in a position substantially perpendicular to the longitudinal axis 37 of side rails 16, 18 and abutting rails 16 and 18. When drawer 14 is inserted into cavity 28 in the closed position, and door 40 is in the closed position, opening 30 (FIG. 1) is substantially sealed maintaining heat within cavity 28. When positional drawer door 40 is moved to the open position, one end of door 40 is disconnected from side rails 16, 18 and the door is positioned substantially parallel to longitudinal axis 37 of side rails 16, 18.

[0025] Drawer frame 38 is further adapted to carry a food tray or pan 42. Food tray 42 may be constructed of materials such as aluminum, stainless steel or other suitable sanitary and heat tolerable material acceptable for food preparation and food service. Food tray 42 may be a shallow or deep type tray. Food tray 42 is adapted to contain a food product (not shown) for heating the food product or maintenance of the heat of the food product. Food tray 42 may be removable supported by drawer frame 38.

[0026] As shown in FIG. 1, the present invention 10 facilitates ease of removal of food tray 42 or insertion of food tray 42 into drawer frame 38 and cabinet 12. In the example shown in FIG. 1, positional drawer door 40 is in the open position and drawer frame 38 is in the open position, extending from cavity 28 of cabinet 12. In this configuration a user may easily slide or lift the heated food tray 42 from drawer frame 38 and cabinet 12 in a manner to reduce the possibility of tipping or sloshing heated liquids in food tray or container 42, or to insert food tray 42 into drawer frame 38.

[0027] The apparatus 10 of the present invention permits a user to quickly move positional door 40 from the closed

and locked position to an open position. With positional door **40** in the open position food tray **42** can be securely gripped by a user and placed into or removed from drawer frame **38**. The present invention provides a novel apparatus and system that promotes safety for the user, ease of use, and conservation of energy.

[0028] FIG. 2 is perspective view of a drawer **14** of the present invention shown in isolation with positional drawer door **40** shown in the open position. With reference to FIGS. 1 through 3, drawer **14** includes a drawer frame **38**, a positional drawer door **40** and a food tray **42**.

[0029] Drawer frame **38** includes a pair of opposing side rails **44, 46** that are slidably connected, respectively, to side walls **16** and **18** of cabinet **12**. Side rails **44, 46** include a front rail end **48** positioned proximate front wall **26** of cabinet **12** when drawer **14** is in the closed position, and a terminal end **50** positioned proximate the back wall **24** of cabinet **12** when drawer **14** is in the closed position. Side rails **44, 46** may be connected in known manners to side walls **16, 18** in a manner to facilitate moving drawer frame **38** between an open position extending from cavity **28**, to a closed position wherein drawer frame **38** is disposed within cavity **28**.

[0030] Drawer frame **38** may further include a front support **52** and/or a back support **54**. Front support **52** being positioned between and substantially perpendicular to side rails **44, 46** and connected proximate to front ends **48** of side rails **44, 46**. Back support **54** may be positioned between and substantially perpendicular to side rails **44, 46** and connected proximate to terminal ends **50** of side rails **44, 46**.

[0031] Positional drawer door **40** is hingedly connected to a lower end **56** of each of the side rail **44, 46** proximate terminal end **50**. Hinged connection **60** permits positional door **40** to be moved in relation to drawer frame **38**. As shown in FIG. 2, hinged or moveable connection **60** includes a bracket **66** connected between positional drawer door **42** and lower end **56** of each side rail **16, 18**. Moveable connection **60** is illustrated as a bolt with a nut, but other means of connection may be utilized. Bracket **66** further includes a slot **68** to allow hinged connection mechanism **60** to be repositioned to facilitate moving door **40** between the open and closed position.

[0032] Drawer **14** includes a locking mechanism **70**. Locking mechanism **70** facilitates selective positioning of drawer door **40** in a closed position, substantially perpendicular to the horizontal axis **37** of drawer frame **38** as referenced with side rails **44, 46** and connected to side rails **44, 46**, to an open position wherein drawer door **40** is substantially parallel to the horizontal axis **37** of drawer frame **38**.

[0033] An illustration of the locking mechanism **70** of the present invention is shown in relation to FIGS. 1 through 3. Locking mechanism **70** includes a holding member **70a** releasably connectable with a probe **70b**. Locking mechanism **70** is positioned in connection with and between side rails **44, 46** and positional drawer door **40**. Locking elements **70a** and **70b** may be arranged in various configurations to accomplish the desired purpose.

[0034] As shown in FIGS. 1 through 3, holding member **70a** includes a tab **72**. Tab **72** extends from side rails **44, 46**

and is positioned proximate the upper end **58** of front end **48** of each side rail **44, 46**. Tab **72** forms a key hole **74**, having a first orifice section **76** and a second orifice section **78**. First and second orifices **76, 78** are in connection to one another. First orifice **76** has a larger diameter than second orifice **78**.

[0035] Locking mechanism **70** further includes probe **70b** adapted for connection with holding mechanism **70a**. Probe **70b** is connected to a positional door opposite the end having hinged connection **60** so as to be alignable with holding member **70a**. Probe **70b** includes a shaft **80** and attached head **82**. Head **82** is sized to be smaller than first orifice **76** and larger than second orifice or second pathway **78**. Shaft **80** is formed to have a smaller diameter than second orifice or **78**.

[0036] The method of use of locking mechanism **70** is described in relation to FIGS. 1 through 3. To close positional door **40**, door **40** is pivoted and raised so that head **82** is aligned with first orifice **76**. Head **82** is inserted through first orifice **76** and door **40** is lowered so that shaft **80** is positioned in second orifice **78**. Head **82** is larger than second orifice **78** and therefore cannot pass through second orifice **78** connecting door **40** and side rails **44, 46** in a locking manner. To move positional door **40** to an open position, door **40** is raised so that head **82** is again aligned with first orifice **76**. Door **40** is then pivoted removing probe **70b** from holding mechanism **70a**. Vertical movement of door **40** in relation to locking mechanism **70** is facilitated by movement of hinged connection **60** and movement of bolt **62** within slot **68**. It should be realized that orientation and connection of holding member **70a** and probe **70b** may be as illustrated or reversed so that probe **70b** is connected to side rails **44, 46** and holding member **70a** is connected to door **40**.

[0037] FIG. 3 is a perspective side view of an embodiment of the present invention in isolation with positional drawer **40** shown in the closed position. Head **82** is shown extending through holding mechanism **70a** locking door **40** in the closed position. Slot **68** can be seen indicating that door **40** may be raised to unlock door **40** for moving to the open position.

[0038] With Reference to FIGS. 1 through 3, the apparatus **10** of the present invention facilitates safe handling of food trays **42** when being inserted into or removed from a heated cavity **28** of a food cabinet **12**. Apparatus **10** includes a drawer frame **38** that is adapted to carry a food tray **42**. The drawer frame and food tray may be moved from an open position wherein the drawer frame and food tray extend from the cabinet and heated cavity to a closed position wherein the drawer frame and food tray are disposed within the cavity. The drawer **40** includes a positional door **40** that can be locked into a closed position in connection with the drawer frame to seal the opening in cabinet **12** when the drawer is closed, to an open position facilitating access for gripping the food tray.

[0039] From the foregoing detailed description of specific embodiments of the invention, it should be apparent that a positional drawer door for a food cabinet that is novel has been disclosed. Although specific embodiments of the invention have been disclosed herein in some detail, this has been done solely for the purposes of describing various features and aspects of the invention, and is not intended to be limiting with respect to the scope of the invention. It is

contemplated that various substitutions, alterations, and/or modifications, including but not limited to those implementation variations which may have been suggested herein, may be made to the disclosed embodiments without departing from the spirit and scope of the invention as defined by the appended claims which follow.

What is claimed is:

1. A drawer having a positional drawer door comprising:
  - a drawer frame having a pair of opposing side rails, each of the side rails having a terminal end and a front end; and
  - a door moveably connected to the front end of the side rails in a manner to be positional between an open position and a closed position.
2. The apparatus of claim 1 further including a food tray removably disposed within the drawer frame.
3. The apparatus of claim 1 further including a locking mechanism in connection between the side rails and the door.
4. The apparatus of claim 3 wherein the locking mechanism includes:
  - a holding mechanism connected to the sides rails proximate the front end thereof, the holding mechanism including a keyhole formed therethrough; and
  - a probe extending from the door and connectable to the holding mechanism in a manner to maintain the door in a locked and closed position.
5. The apparatus of claim 3 wherein the locking mechanism includes:
  - a holding mechanism connected to the door, the holding mechanism including a keyhole formed therethrough; and
  - a probe connected to and extending from each of the side walls proximate the front end thereof connectable to the holding mechanism in a manner to maintain the door in a locked and closed position.
6. The apparatus of claim 1 wherein the door is hingedly connected to the side rails proximate the front end thereof.
7. The apparatus of claim 1 wherein the drawer frame is insertable within a heated cavity formed by a cabinet.
8. The apparatus of claim 3 wherein the door is hingedly connected to the side rails proximate the front end thereof.
9. The apparatus of claim 4 wherein the door is hingedly connected to the side rails proximate the front end thereof.
10. The apparatus of claim 5 wherein the door is hingedly connected to the side rails proximate the front end thereof.
11. The apparatus of claim 3 further including a food tray removably disposed within the drawer frame.
12. The apparatus of claim 6 further including a food tray removably disposed within the drawer frame.
13. The apparatus of claim 7 further including a food tray removably disposed within the drawer frame.
14. A food warmer oven comprising:
  - a cabinet having opposing side walls, a top wall, a bottom wall, a back wall, and a front wall defining a heating cavity, the front wall defining an opening into the heating cavity;
  - a heating source disposed within the heating cavity;

- a drawer frame having a pair of opposing side rails, each of the side rails having a front end and a terminal end, the side rails being functionally connected with the side walls of the cabinet in a manner such that the drawer frame can be moved between an open position wherein the drawer frame extends substantially exterior of the heating cavity through the opening and a closed position wherein the drawer frame is positioned substantially within the heating cavity, the front end of the side rails being positioned proximate the front wall and the terminal end being positioned proximate the back wall when the drawer frame is in the closed position;
  - a food tray removably held by the drawer frame;
  - a door moveably connected to the side rails of the drawer frame, the door moveable between an open position and a closed position; and
  - a locking mechanism in connection between the door and the side rails of the drawer frame for selectively maintaining the door in the closed position.
15. The food warmer oven of claim 14 wherein when the door is in the closed position the door substantially seals the opening formed through the front wall of the cabinet.
  16. The food warmer oven of claim 14 wherein the locking mechanism includes:
    - a holding mechanism connected to the sides rails proximate the front end thereof, the holding mechanism including a keyhole formed therethrough; and
    - a probe extending from the door and connectable to the holding mechanism in a manner to maintain the door in a locked and closed position.
  17. The food warmer oven of claim 14 wherein the locking mechanism includes:
    - a holding mechanism connected to the door, the holding mechanism including a keyhole formed therethrough; and
    - a probe connected to and extending from each of the side walls proximate the front end thereof connectable to the holding mechanism in a manner to maintain the door in a locked and closed position.
  18. A method of maintaining a temperature of food products comprising the steps of:
    - providing a food warmer oven comprising:
      - a cabinet having opposing side walls, a top wall, a bottom wall, a back wall, and a front wall defining a heating cavity, the front wall defining an opening into the heating cavity,
      - a heating source disposed within the heating cavity,
      - a drawer frame having a pair of opposing side rails, each of the side rails having a front end and a terminal end, the side rails being functionally connected with the side walls of the cabinet in a manner such that the drawer frame can be moved between an open position wherein the drawer frame extends substantially exterior of the heating cavity through the opening and a closed position wherein the drawer



frame is positioned substantially within the heating cavity, the front end of the side rails being positioned proximate the front wall and the terminal end being positioned proximate the back wall when the drawer frame is in the closed position,

- a door moveably connected to the side rails of the drawer frame, the door moveable between an open position and a closed position, and
- a locking mechanism in connection between the door and the side rails of the drawer frame for selectively maintaining the door in the closed position;

providing a desired temperature within the heating cavity;

pulling the door and drawer frame substantially through the front wall opening from the heating cavity;

manipulating the door to disconnect the door from the drawer frame via the locking mechanism;

moving the door to the open position;

removing a food tray from the drawer frame;

placing a food tray in the drawer frame;

moving the door to the closed position; and

manipulating the door to secure the door to the door frame via the locking mechanism.

**19.** The method of claim 19 wherein the locking mechanism includes:

- a holding mechanism connected to the sides rails proximate the front end thereof, the holding mechanism including a keyhole formed therethrough; and

- a probe extending from the door and connectable to the holding mechanism in a manner to maintain the door in a locked and closed position.

**20.** The method of claim 19 wherein the locking mechanism includes:

- a holding mechanism connected to the door, the holding mechanism including a keyhole formed therethrough; and

- a probe connected to and extending from each of the side walls proximate the front end thereof connectable to the holding mechanism in a manner to maintain the door in a locked and closed position.

\* \* \* \* \*