



INTERNATIONAL APPLICATION PUBLISHED UNDER THE PATENT COOPERATION TREATY (PCT)

<p>(51) International Patent Classification ⁶ : G06F 17/60</p>	<p>A1</p>	<p>(11) International Publication Number: WO 98/49639 (43) International Publication Date: 5 November 1998 (05.11.98)</p>
<p>(21) International Application Number: PCT/GB98/01240 (22) International Filing Date: 29 April 1998 (29.04.98)</p> <p>(30) Priority Data: 60/045,229 30 April 1997 (30.04.97) US 9716983.3 11 August 1997 (11.08.97) GB 9721355.7 8 October 1997 (08.10.97) GB</p> <p>(71)(72) Applicant and Inventor: LAWRIE, Roderick, Malcolm, Gordon [GB/GB]; The Coach House, 17 Victoria Road, Broughty Ferry, Dundee DD5 1BL (GB).</p> <p>(74) Agents: BERESFORD, Keith, Denis, Lewis et al.; Beresford & Co., 2-5 Warwick Court, High Holborn, London WC1R 5DJ (GB).</p>	<p>(81) Designated States: AL, AM, AT, AU, AZ, BA, BB, BG, BR, BY, CA, CH, CN, CU, CZ, DE, DK, EE, ES, FI, GB, GE, GH, GM, GW, HU, ID, IL, IS, JP, KE, KG, KP, KR, KZ, LC, LK, LR, LS, LT, LU, LV, MD, MG, MK, MN, MW, MX, NO, NZ, PL, PT, RO, RU, SD, SE, SG, SI, SK, SL, TJ, TM, TR, TT, UA, UG, US, UZ, VN, YU, ZW, ARIPO patent (GH, GM, KE, LS, MW, SD, SZ, UG, ZW), Eurasian patent (AM, AZ, BY, KG, KZ, MD, RU, TJ, TM), European patent (AT, BE, CH, CY, DE, DK, ES, FI, FR, GB, GR, IE, IT, LU, MC, NL, PT, SE), OAPI patent (BF, BJ, CF, CG, CI, CM, GA, GN, ML, MR, NE, SN, TD, TG).</p> <p>Published <i>With international search report.</i></p>	

(54) Title: NETWORK COMPUTER TRADING SYSTEM

(57) Abstract

A network computer trading system is provided comprising a central server station (1) connected to a number of user stations (2) by a high bandwidth distribution system (3). The central server station (1) includes a mass data storage system (13) having stored therein a main input interface for inputting a selection of a type of commodity to be traded and a plurality of commodity interfaces for inputting product details of specific commodities, wherein each of the plurality of commodity interfaces is arranged to enable the input of data relating to a respective different one of a plurality of commodities. A user can select which type of commodity he wishes to trade via the main input interface and then enter data relevant to trading that commodity using the respective commodity interface.

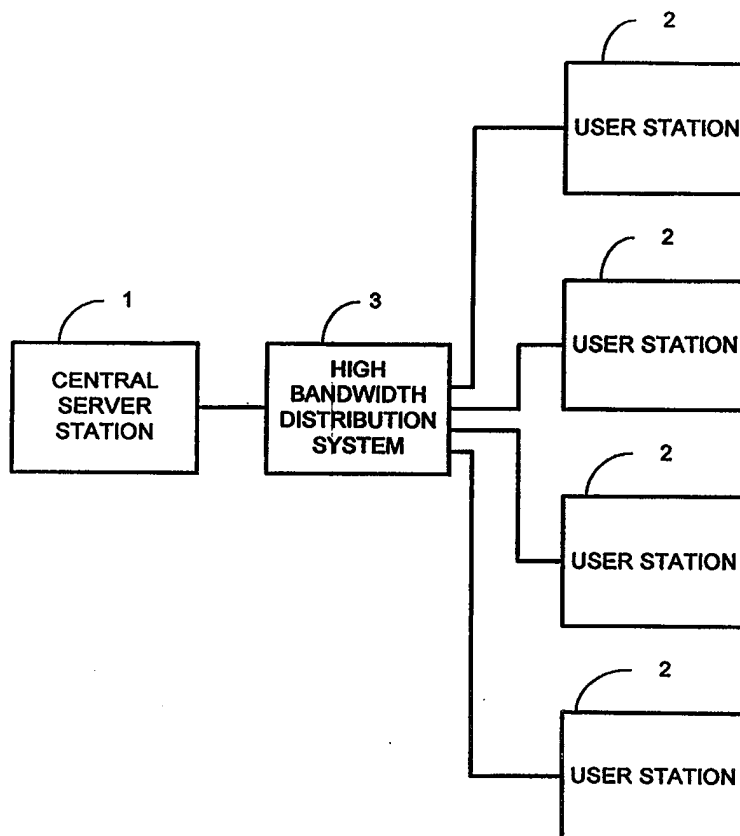

FOR THE PURPOSES OF INFORMATION ONLY

Codes used to identify States party to the PCT on the front pages of pamphlets publishing international applications under the PCT.

AL	Albania	ES	Spain	LS	Lesotho	SI	Slovenia
AM	Armenia	FI	Finland	LT	Lithuania	SK	Slovakia
AT	Austria	FR	France	LU	Luxembourg	SN	Senegal
AU	Australia	GA	Gabon	LV	Latvia	SZ	Swaziland
AZ	Azerbaijan	GB	United Kingdom	MC	Monaco	TD	Chad
BA	Bosnia and Herzegovina	GE	Georgia	MD	Republic of Moldova	TG	Togo
BB	Barbados	GH	Ghana	MG	Madagascar	TJ	Tajikistan
BE	Belgium	GN	Guinea	MK	The former Yugoslav Republic of Macedonia	TM	Turkmenistan
BF	Burkina Faso	GR	Greece	ML	Mali	TR	Turkey
BG	Bulgaria	HU	Hungary	MN	Mongolia	TT	Trinidad and Tobago
BJ	Benin	IE	Ireland	MR	Mauritania	UA	Ukraine
BR	Brazil	IL	Israel	MW	Malawi	UG	Uganda
BY	Belarus	IS	Iceland	MX	Mexico	US	United States of America
CA	Canada	IT	Italy	NE	Niger	UZ	Uzbekistan
CF	Central African Republic	JP	Japan	NL	Netherlands	VN	Viet Nam
CG	Congo	KE	Kenya	NO	Norway	YU	Yugoslavia
CH	Switzerland	KG	Kyrgyzstan	NZ	New Zealand	ZW	Zimbabwe
CI	Côte d'Ivoire	KP	Democratic People's Republic of Korea	PL	Poland		
CM	Cameroon	KR	Republic of Korea	PT	Portugal		
CN	China	KZ	Kazakstan	RO	Romania		
CU	Cuba	LC	Saint Lucia	RU	Russian Federation		
CZ	Czech Republic	LI	Liechtenstein	SD	Sudan		
DE	Germany	LK	Sri Lanka	SE	Sweden		
DK	Denmark	LR	Liberia	SG	Singapore		
EE	Estonia						

NETWORK COMPUTER TRADING SYSTEMTechnical Field

The present application is concerned with the field of networked computer trading systems.

5 Background art

When an individual wishes to purchase a product, if he wishes to obtain that product at the cheapest price, it is necessary to contact a number of suppliers and check the prices offered by those suppliers before
10 deciding on which of the suppliers he will deal with. After the individual has reviewed all the options, a request is then sent to the supplier who can then confirm a contract.

Reviewing prices offered by suppliers and the
15 placing of contracts has for many years taken place using telephones, fax machines, letters and face to face meetings. Reviewing the prices of a number of different suppliers is complicated because of the need to repeat to each supplier the details of the product. When this
20 is done by telephone this requires an individual to repeat the order every time a call is made. If an enquiry is made by letter or facsimile, separate copies of the letter need to be sent to each of the suppliers. This repeated entry of product details is time consuming
25 and inefficient.

In order to overcome the above problem, a number of networked computer trading systems have been proposed.

An example of a known networked computer trading system is that disclosed in US-A-5285383. This discloses a trading system having a centralised computer database which is used for trading bales of cotton. The system comprises a number of computer terminals which are connected to and can access data stored in the central database. When a bale of cotton is processed, its details are entered onto the database via a computer terminal. Data relating to the bale can be accessed by other users of the system using their own computer terminals. When an individual wishes to purchase a bale of cotton all the relevant details of the available bales are displayed on his computer terminal. An individual can then input a request to purchase the bale of cotton which causes the database to be updated to indicate the change of ownership of that bale. Account details of the users of the system are kept and updated in accordance with the purchase and sale of different bales of cotton.

Another example of a computerised trading network is disclosed in US-A-4677552. This document is concerned with an international commodity exchange in which computer terminals are connected to local exchanges by a central exchange host and the computer terminals can transmit and receive data via that host either to or from computers connected to the host or to or from other networks of computers connected to other exchange hosts. The network can be used to trade commodities which are

defined by a single predefined set of parameters. When bids for commodities are entered into the system other users can retrieve the bid information which is displayed on screen in price order.

5 Disclosure of the invention

In one aspect the present application provides a computerised network trading system which is more flexible than those of the prior art. In one aspect, the present invention provides a networked computer trading
10 system in which enquiries relating to different types of commodity can be easily input and efficiently processed.

In one aspect the present invention provides a networked computer trading system or a server station for use in such a network which enables a user to select a
15 commodity in which he desires to trade and then present the user with an interface specifically adapted for that commodity and, for example, selected from a number of different interfaces stored by the system and each adapted for trading a different commodity. The
20 specifically adapted interfaces may enable a user to enter information particularising features of the commodity desired to be bought or sold.

In one aspect the invention provides a computerised network trading system in which commodities represented
25 by different amounts of data can be traded in a manner which enables the data describing those commodities to be displayed in a manner dependent upon the amount and

type of data used to define a commodity.

In one aspect, the present invention provides an arrangement by which users of a computerised network trading system can be put in contact with one another by submitting an initial query to a central user station which generates output data which enables users fulfilling the criteria of that query to be located and for the different users of the system to be put in contact dependent on the outcome of an initial query.

10 In accordance with one aspect of the present invention there is provided a networked computer trading system comprising a central server station comprising:

means for receiving and transmitting data to and from a plurality of user stations and a mass data storage system; and

15

a plurality of user stations arranged to receive and transmit data to and from said central server station, characterised by said system having stored therein a main input interface for inputting a selection of a type of commodity to be traded and a plurality of commodity interfaces for inputting product details of specific commodities, wherein each of said plurality of commodity interfaces is arranged to enable the input of data relating to a respective different one of a plurality of commodities, said system further comprising means for transmitting in response to a request received from a said user station, said main input interface; and

20

25

means for transmitting a said commodity interface,
in response to a request received from a said user
station using said main input interface.

In accordance with one aspect of the present
5 invention there is provided a central server station for
use in a networked computer trading system comprising:

means for receiving and transmitting data to and
from a plurality of user stations; and

a mass data storage system;

10 characterised by:

said mass data storage system having stored therein
a main input interface for inputting a selection of a
type of commodity to be traded and a plurality of
commodity interfaces for inputting product details of
15 specific commodities, wherein each of said plurality of
commodity interfaces is arranged to enable the input of
data relating to a respective different one of a
plurality of commodities;

means for transmitting in response to a request
20 received from a said user station, said main input
interface; and

means for transmitting a said commodity interface,
in response to a request received from a said user
station using said main input interface.

25 In accordance with a further aspect of the present
invention there is provided a central server station for
use in a networked computer trading system comprising:

means for receiving and transmitting data to and from a plurality of user stations; and

a mass data storage system;

characterised in that:

5 said mass data storage system has stored therein a main input interface template defining an interface for selecting a type of commodity to be traded and a plurality of commodity interface templates each defining an input interface for inputting product details of
10 specific commodities, wherein each of said plurality of commodity interface templates is arranged to enable input of data relating to a respective different one of the plurality of commodities which can be selected using the main interface defined by the main interface template.

15 In this application the term "template" is used to describe stored data which defines the format of a display. A template therefore includes instructions as to what is to be displayed on a screen and also to the manner in which it is to be displayed on the screen. The
20 template may also include other data which is not directly relevant to displaying information on a screen.

Embodiments of the present invention will now be described, by way of example, with reference to the accompanying drawings, in which:

25 Figure 1 is a schematic diagram of a computer network to which the invention of the present application can be applied.

Figure 2 is a schematic diagram of a central server station of the network shown in Figure 1.

Figure 3 is a memory map of a mass data storage system shown in Figure 2.

5 Figure 4 is a block diagram of data within a product database.

Figure 5 is a block diagram of data within an account database.

10 Figure 6 is a block diagram of programs stored in a memory of the central server station.

Figure 7 is a schematic diagram of a user station.

Figures 8A and 8B show a flow diagram describing the use of a trading system in accordance with a first embodiment of the invention.

15 Figure 9 is an example of a main input interface.

Figure 10 is an example of an input interface for inputting a query to interrogate one of a number of dedicated databases stored in a mass storage system.

Figure 11 is an example of an output display.

20 Figure 12 is a memory map of a mass data storage system of a network trading system in accordance with a second embodiment of the invention.

25 Figure 13 is a block diagram of the memory of a central server station of a network trading system in accordance with a second embodiment of the invention.

Figures 14A & 14B show a flow diagram for describing the use of a trading system in accordance with a second

embodiment of the invention.

Figure 15 is an example of an initial input interface.

Figure 16 is an example of an account entry
5 interface.

Figure 17 is an example of a seller interface.

Figure 18 is an example of an input interface for
inputting data into one of the product databases.

Embodiments

10 Figure 1 is a schematic diagram of a computer network to which the invention of the present application can be applied. The computer network shown in Figure 1 comprises a central server station (1) which is connected to a number of user stations (2) via a high band width
15 distribution system (3) such as a LAN (Local Area Network), WAN (Wide Area Network) or telephone network, e.g. the Internet. This arrangement enables the plurality of users at the different user stations to communicate with the central server station (1)
20 simultaneously. The provision of a central server station (1) reduces network traffic as the user stations (2) initially communicate with a single server rather than needing to communicate directly with each other.

Figure 2 is a schematic diagram of the central
25 server station (1) shown in Figure 1. The central server station (1) comprises a central processing unit (10), hereinafter referred to as a CPU, which is connected to

the high band width distribution system (3) via an interface (11). The CPU (10) is also connected to a memory (12) which contains programs for controlling the actions of the CPU (10) and is used for the temporary storage of variables. The CPU (10) is also connected to a mass data storage system (13), a display (14) and an input device (15) such as a keyboard. Also connected to the CPU (10) is a disk drive (17) which is arranged to read data from a disk (18). Data read from the disk (18) is then stored in the memory (12) or the mass data storage system (13). In this way a disk (18) containing instructions to generate the data stored in the mass data storage system (13) and the programs stored in memory (12) can be used to set up the system as will be described in detail hereafter. The disk (18) used could be a magnetic, optical or magneto-optical disk.

Figure 3 is a memory map of the mass data storage system (13) shown in Figure 2. The mass data storage system (13) is arranged to store a plurality of databases (130a-130n), each of the databases (130a-130n) being a database dedicated to one type of commodity which is to be traded on the computer system. Also stored on the mass data storage system are a plurality HTML (Hyper Text Markup Language) scripts defining interface templates (131a-131n) for inputting a query to interrogate a respective one of the databases (130a-130n), and an HTML script (132) defining a main interface template for

inputting an initial query into the system as will be described later. A plurality of HTML scripts defining output templates (133a-133n) for formatting the result of a query to the databases (130a-130n) are also stored
5 in the mass data storage system, as is an account database (134) for storing account data on the users of the trading system.

Figure 4 is a block diagram of data within one of the product databases (130a-130n). Each of the databases
10 (130a-130n) comprises a plurality of records (1000). Each of the records comprises data indicative of an offer which has been entered into the trading system. Each record comprises an identification number (1001), a plurality of product details (1002) which define the
15 product which is on offer, price data (1003) defining the price of the product on offer and supplier ID data (1004) identifying the supplier who is making the offer.

The product details contained within any particular database (130a-130n) are determined by the type of
20 commodity which is to be offered. For example, if the product related to a case of wine, the type of product details stored would relate to wine and the data stored as product details might comprise the following entries:

Year: 1986
25 Region: Latour
and so on.

If the product were to be something like car

insurance, different details would be stored within a record such as the occupation, sex and address of the driver, the make, model and age of the car to be driven and details about the type of cover which is to be requested.

Each of the records within one of the databases (130a-130n) will have the same type of product details (1002). However, records in different databases (130a-130n) will have different types of product details (1002). In this way the data stored defines exactly the commodity on offer, and within each database (130a-130n) only records relating to one type of commodity are stored. The databases (130a-130n) could be implemented by any commercially available relational database program, such as Microsoft Access.

Figure 5 is a block diagram of data within the account database (134) stored in the mass data storage system (13). The database comprises a plurality of account records (2000), one for each of the suppliers which has an offer entered on the trading system. Each record comprises supplier ID data (2001) which is a number which corresponds to the supplier ID data (1004) in the records (1000) entered in the databases (130a-130n) indicative of offers by that supplier, hit data (2002) indicative of the number of times a record of an offer by that supplier is retrieved from the databases (130a-130n), value data (2003) indicative of the

cumulative value of the offers retrieved by that supplier from the databases (130a-130n) and address data (2004-2005) indicative of the network address (2004) and postal address (2005) of that supplier.

5 Figure 6 is a block diagram of the programs stored in the memory (12) of the central server station (1). The programs in the memory (12) comprise a database entry program (120) for controlling the entry of data onto the databases (130a-130n), a database query program (121) for
10 receiving database queries and interrogating the databases (130a-130n) and a database output program (123) for formulating an HTML script from the output templates (133a-133n) and the result of a query of the databases (130a-130n) retrieved by the database query program. The
15 memory (11) also has stored therein an account database entry program (123) for outputting and updating data in the account database (134), and an account data retrieval program (123) for retrieving and outputting data from the account database (134). Also stored in the memory is a
20 data processing program (125) for processing data received from the high band width distribution system (3) via the interface (21). This program is arranged to process data so that it is suitable for use by the database query program (121) and is also arranged to
25 determine, based on data received, which of the HTML scripts stored in the mass data storage system (13) should be the next one transmitted to a user station (2).

After the system is initially set up, data is entered into the central server station (1) using the input device (15) or alternatively data is loaded from a disk (18) via the disk drive (17). The entered data is processed in accordance with the database entry program (120) or the account database program (123), and stored in the databases (130-130n) as a data record (1000) or in the account database (134) as an account record (2000) respectively. The database entry program (120) and the account database program (123) both enable a user to edit data records. In this case, the database entry program (120) or the account database program (122) causes a data record (1000) or account record (2000), which has already been stored in the mass data storage system (13) to be shown on the display (14) and then overwritten by new data entered using the input device (15).

Figure 7 is a schematic diagram of a user station (2) as shown in Figure 1. The user station comprises a central processing unit (20) (hereinafter referred to as a CPU), which is connected to the high bandwidth distribution system (3) via an interface (21) e.g. MODEM. The CPU (20) is also connected to a memory (22) having a browser program stored therein, a display (23), a keyboard (24) and a mouse (25). If the distribution system (3) is provided by the Internet, the browser program could be any of the commercially available

browser programs such as Netscape Navigator or Microsoft Internet Explorer. The CPU (20) is arranged to process data received from the high bandwidth distribution system (3) via the interface (21) in accordance with the browser program stored in the memory (22). The CPU (20) is also arranged to process data received via the keyboard (24) and the mouse (25) in accordance with the browser program and also to cause data to be transmitted via the interface (21) and the high bandwidth distribution system (3) back to the central server station (1).

Figure 8 is a flow diagram for describing the use of the networked trading system of the present embodiment.

When the browser program is first invoked the program causes a connection to be made between the user station (2) and the central server station (1) via the high bandwidth distribution system (3) (S1). When a connection has been made the browser program downloads (S2) the HTML script (132) defining a main interface template for inputting an initial query into the system. The HTML script (132) defining the main interface is then processed by the browser program which causes a main input interface to be displayed (S3) on the display (23).

Figure 9 is an example of a main input interface displayed on the display (23). The main input interface contains a request (500) prompting a user to input the type of commodity he wishes to trade. The user can then

input the type of commodity he wishes to trade using the keyboard (24), in which case the user's choice of commodity is displayed in a window (501) shown on the display (23). Alternatively, a user may select a commodity from a list of commodities (502) using a mouse (25) to direct a pointer (503). When the user has made his choice (S4), he can send his query to the central server station (1). This occurs when the browser program detects that either the return button on the keyboard (24) has been pressed or the mouse (25) has directed the pointer (503) onto a send button (504) displayed on the display (23). The browser program then causes a request to be sent (S5) to the central server station (1) via the interface (21) and the high band width distribution system (3) requesting download of a new HTML script, together with the data which has been entered using the main interface (500-504).

When the request and data are received by the interface (11) of the central server station (1) the data is processed (S6) by the data processing program (125) stored in the memory (12) of the central server station (1). This program generates a request to download the specific HTML script (131a-131n) corresponding to the commodity selected by the user. This template is then downloaded from the central server station (1) via the high band width distribution system (3) and the interface (21) into the memory (22) of the user station (2) (S7).

The browser program then causes the display (23) to show (S8) the input interface corresponding to the template now stored in memory (22).

Figure 10 is an example of such an input interface
5 for inputting a query to interrogate one of the dedicated
databases stored in the mass storage system (13). The
interface comprises a number of windows (600) each for
inputting data relating to a respective different one of
the different categories of product details of the
10 records (1000) stored in the database (130a-130n) for
which the interface is intended. Next to each of the
windows are the names (601) of the categories of the
product details which are to be entered. Also on the
screen are displayed a back button (602) and a send
15 button (603) and a pointer (604).

Tables 1 and 2 are examples of the names (601) of
categories displayed as part of an input interface for
inputting product details for purchasing wines and for
purchasing car insurance, respectively. In this way a
20 user is prompted to enter data relevant to the specific
commodity he wishes to purchase.

17

Table 1

5 COUNTRY
REGION
YEAR
QUALITY
GRAPE
COLOUR

Table 2

10 MAKE
MODEL
YEAR
TRANSMISSION
NAME OF DRIVER
15 ADDRESS OF DRIVER
AGE OF DRIVER
SEX OF DRIVER
NO CLAIMS
ACCIDENTS LAST 5 YEARS

20

The user can enter a database query (S9) by using the mouse (25) to direct the pointer (604) to the category of product detail which is to be entered and then entering the product detail data using the keyboard (24). When the user enters data the browser program causes the data to be displayed in the window (600) adjacent to the category selected. When the user has finished entering data he can use the mouse (25) to move a pointer (604) onto either the back button (603) or the send button (603).

30

If the user selects the back button (602)(S10) a request is sent to the central server station (1) via the interface (21) and the high bandwidth distribution system (3) to download the HTML script corresponding to the main

interface (S2) once again (132) and control continues as if the main interface had been downloaded for the first time.

If the user selects the send button (603) the database query which has been entered via the interface (600-604) is sent (S11) to the central server station (1) via the interface (21) and the high band width distribution system (3) together with a request download an output HTML script.

When the central server station (1) receives a database query from a user station (2) via the high bandwidth distribution system (3) and the interface (11), this causes the CPU to invoke the database processing program (125) to process the data into a form suitable for use by the database query program (121). The database query program (121) is then invoked to retrieve from the appropriate database (130a-130n) records which match the database query (S12).

The database output program is then invoked to incorporate records which are retrieved from the database (130a-130n) into the HTML script (133a-133n) for the output template for that database (130a-130n). The network addresses (2004) of the suppliers which have supplier ID data (2001) corresponding to the supplier ID data (1004) of the records (1000) retrieved from the database (130a-130n) are retrieved from the account records (2000) stored in the account data base (134). The

database output program (122) then incorporates links to these network addresses in the output script (S13).

The newly formulated output script is then sent to the user station (2). At the same time, the account database entry program (123) is invoked by the central server station (1) to update the account data (2000) corresponding to those suppliers whose records have been retrieved by the database query program (121) (S14). The account database program (123) increments the hit data (2002) in the record (2000) which has supplier ID data (2001) corresponding to the supplier ID data (1004) in the records (1100) retrieved by the database query program (121). The account database program (123) also causes the value data (2003) in the records (2000) which have supplier ID data (2001) corresponding to the supplier ID data (1004) in the records (1000) retrieved by the database query program, to be incremented by the amount of the price data (1003) in the records (1000) retrieved. In this way the hit data (2002) is updated to reflect the number of times a supplier's records are retrieved from the system and the value data (2003) is updated to reflect the value of the offers retrieved for that supplier.

When the output script has been sent to the user station (2), it is then displayed (S15) on the display (23).

An example of an output display is shown in figure

11. At the top of the display details of the query sent by the user (700) are shown. The display also has a window (701) showing the names of a number of suppliers and the price at which they offer the commodity defined
5 by the user's query. The entries in the list are displayed in price order. At the bottom of the screen are a send button (702) and a back button (703).

The user can select any of the offers displayed by using the keyboard (24) or the mouse (25) to move a
10 pointer (704). If an offer is selected (S16), this causes the browser program to display the selected offer in a window (705). If the user then selects the send button (702), the browser program invokes the link to the network address of that supplier to cause a request to
15 download the web page corresponding to that supplier to be sent to the web site of that supplier. In this way the user can be put in contact with the supplier which provides him with the best offer (S17).

If the user selects the back button (703) using the
20 keyboard (24) or the mouse (25), a request is sent to the central server station (1) via the high band width distribution system (3) to download the previous database query interface (S7) and control continues as if the interface had been downloaded for the first time.

25 The above described embodiment, therefore, provides a simple and efficient way in which a user can determine which of a number of suppliers of a particular product

can offer that product at an acceptable price. The system also enables a user to select suppliers of different products from a single entry point whilst providing the user with an appropriate interface for inputting details relating to specific products. The use of the system can be monitored at any time by retrieving the account data for each supplier using the account retrieval program (123) and a supplier can be billed appropriately in relation to the number of times his records are retrieved and the value of the offers which have been shown to individuals using the system, as indicated by the hit data (2002) and the value data (2003) respectively. The postal address (2005) indicates where such bills should be sent and provides a record of the suppliers using the system.

A second embodiment of the present invention will now be described. In the first embodiment data records stored in the product databases (130a-130n) and account records stored in the account database (134) were both entered into the mass storage system (13) using an input device (15) of the central server station (1). In this embodiment, data records (1000) and account records (2000) can be entered remotely from a user station (2). In this way, users of the system can enter their own offers of products which are then made available to the other users of the system in the manner which has previously been described.

Figure 12 is a memory map of the mass data storage system (13) in accordance with this embodiment of the invention. Elements of the memory map of the mass data storage system (13), which have previously been described in relation to the first embodiment, are indicated by the same reference numerals and will not be described again.

In addition to the plurality of databases (a-130n) and the plurality of HTML scripts (131a-131n, 132, 133a-133n) and the account database (134) stored in the mass data storage system (13) which have previously been described in relation to the first embodiment, the mass storage system (13) also has stored therein an HTML script corresponding to an initial interface template (135), an account entry interface template (135) for defining an interface for entering data into the account database (134), an HTML script (137) corresponding to a sell template defining an input interface for selecting which commodity a user wishes to sell, and a plurality of input interface templates (138a-138n) defining input interfaces for inputting entries into the product databases (130a-130n).

Figure 13 is a block diagram of the memory (12) of the central server station (1) in this embodiment. The memory (12) has stored therein programs corresponding to the programs (120-125) previously described in relation to the first embodiment, which are indicated by the same reference numerals, and description of these programs

will not be repeated here. In addition to the programs already described (120-125), the memory (12) has additionally stored therein a remote input program (126) for processing data received from user stations (2) via the interface (11) and the high band width distribution system (3) for use by the database entry program (120) and the account entry program (123) as will be described in detail later.

Figure 14 is a flow diagram describing the use of the network trading system of the present embodiment.

When the browser program is first evoked, the program causes a connection to be made between the user station (2) and the central server station (1) via the high band width distribution system (3) (S20). When a connection has been made the browser program downloads (S21) the HTML script defining an initial interface (135). The HTML script (135) defining the initial interface is then processed by the browser program which causes an initial interface to be displayed (S22) on the display (23) of the user station (2).

Figure 15 is an example of an initial input interface displayed on the display (23) of a user station in accordance with the present embodiment. The initial (2) interface comprises a welcome message (800) welcoming the user to the networked trading system and prompting a user to decide whether he wishes to buy or sell using the networked trading system. On the lower half of the

screen there is a buy button (801), a sell button (802) and a pointer (803). The user can choose whether to buy or sell using the networked trading system by moving the mouse (25) to cause the pointer (803) to point to the buy
5 button (801) or the sell button (802) and clicking the mouse (25) or, alternatively, by using the keyboard (24). In this way, a user can select whether to buy or sell using the network trading platform (S23).

When a user has made his choice, depending upon
10 which button (801,802) has been selected, a request to download either the account entry interface template (136) or the main interface template (132) is sent to the server station (1) (S24).

When the request is received by the central server
15 station (1), if it is a request to download the main interface template (132), the flow of control continues in the same manner as has previously been described in relation to the first embodiment (S2-S17) which will not be repeated here.

20 If a request to download the account entry interface (136) is received by the central server station (1), the browser program downloads (S25) the HTML script (136) defining an account entry interface for inputting account data into the account database (134) (S25). The HTML
25 script (136) defining the account entry interface is then processed by the browser program which causes an account entry interface to be displayed (S26) on the display

(23).

Figure 16 is an example of an account entry interface displayed on the display (23). The interface comprises a list of details (900) which the user can enter and a plurality of windows (901-903) for displaying the details as they are entered. The windows (901-903) correspond to windows for entering data representative of supplier ID data (901), postal address data (902) and web address data (903). In the lower half of the display there is shown a send button (904) and a pointer (905).

The user can then enter data (S27) by using the mouse (25) which causes the pointer (905) to move to one of the windows (901-903). When the user enters data using the keyboard (24) the data is displayed in the window (901-905) which is currently selected. When the user has finished entering data via the keyboard (24) he can move the mouse (25) to cause the pointer (905) to select the send button (904).

If the user selects the send button, the browser program sends (S28) the data which has been entered via the interface (900-905) to the central server station (1) via the interface (21) and the high band width distribution system (3), together with a request to download the sell template (137) stored in the mass data storage system (13).

When the data is received by the central server station (1) this causes the remote input program (126)

to be invoked which transforms the data into a request suitable for use by the account retrieval program (124). The account database (134) is then checked to see if the record already exists corresponding to this particular user. In this way, if the user has already registered with the networked trading system, the user need only enter some of the data into the windows (901-903). If no records exist in the account database (134) which match the data entered by the user, the remote input program (126) then causes the account entry program to create a new account record (2000) incorporating the data which has just been entered (S29). In these circumstances, the remote input program will generate supplier ID data for that user. The retrieved or generated supplier ID data (2001) is then incorporated into the HTML script stored as a seller template (137) which is then downloaded by the user station (1) (S30).

When the user station (2) has received the HTML script for the sell template (136), the browser program stored the supplier ID data (2001) in memory and then causes a seller interface to be displayed (S31) on the display (23).

An example of a seller interface is shown in figure 17. The seller interface contains a request (1100) prompting a user to input the type of commodity he wishes to sell and also informing the user of his supplier ID data (2001). The user inputs the type of commodity he

wishes to sell using the keyboard (24), or alternatively the user by selecting a commodity from a list of commodities (1100). When the user has made his choice (S32) the selected data is displayed in a window (1001).

5 The user can then submit his choice to the central server station (1). This occurs when the browser program detects that either the return button on the keyboard (24) has been pressed or the mouse (25) has directed a pointer (1103) onto a send button (1104) shown on the

10 display (23). The browser then causes a request to be sent (S33) to the central server station (1) via the interface (21) and the high band width distribution system (3) requesting to download a new HTML script, together with data representative of the user's

15 selection.

When the request and data are received by the interface (11) of the central server station (1), the data is processed by the data processing program (125) stored in the memory (12) of the central server station

20 (1). This program transforms the request into a request download a specific HTML script (138a-138n) from the database of HTML scripts defining interface templates for inputting details onto the product databases (130a-130n). The input template corresponding to the type of commodity

25 the user has indicated he wishes to sell is then downloaded by the user station (2) (S34). The browser then causes the display (23) to show (S35) the input

interface corresponding to the template now stored in memory (22).

Figure 18 is an example of an input interface for inputting data onto one of the product databases (130a-5 130n). The interface comprises a plurality of windows (1200) for inputting data relating to the different product details defining the product on sale. The interface also has a window (1201) for inputting price data. Next to each of the windows for inputting product 10 details (1200) is a description of the category of product detail which is to be entered in that window (1202). Next to the window for inputting price data (1201) is a message indicating that price data should be entered in that window (1203). Also on the screen are 15 displayed a back button (1204), a send button (1205), and end button (1206) and a pointer (1207).

The user can enter data (S36) which is to be stored in a product database (130a-130n) by selecting one of the windows using the mouse (25) to direct the pointer (1206) 20 to one of the windows (1201-1202) typing in the product details using the keyboard (24). When the browser program detects that data is being entered, it causes the data to be displayed in the respective window (1200-1201). When the user has finished entering data he can 25 use the mouse (25) to move a pointer (1207) onto either the back button (1204) or the send button (1205), or the end button (1206).

If the user selects the back button (1204) a request is sent to the central server station (1) via the interface (21) and the high band width distribution system (3) to download (S30) the HTML script corresponding to the sell template (137) once again and continues as if the sell template had been downloaded for the first time.

If the user selects the send button (1205) the product details and price data which have been entered via the interface (1200-1206), then sent (S37) to the central server station (1) via the interface (21) and the high band width distribution system (3), together with the supplier ID data previously stored in memory (22). When the data is received by the central server station (1), remote input program (126) is invoked which processes the data into a form which is suitable for use by the database entry program (120). The database entry program (120) then creates and edits records (S38) stored in the database (130a-130n) in accordance with the data received from the user station (2).

After a selection of data has been sent to the central server station, the user can amend the product details (1200) and price data (1201) to create a new selection of data which can be sent to the central server station (1). In this way a number of records (1000) in the database can be amended or created.

When the user has finished entering data he can move

the pointer (1207) onto the end button (1206). When the browser program detects that this has happened, the program comes to an end.

Although the previous embodiments have been described in which a user is put in direct contact with a supplier and the number of times a supplier's network address is incorporated into HTML scripts downloaded by users is monitored, it will be appreciated that the network trading system could instead generate orders for the products requested and send those orders to the suppliers without the users themselves ever being placed in direct contact with the supplier.

Although in the previous embodiments reference has been made to the storage and retrieval of HTML scripts defining interface templates and output templates, it will be appreciated that any data which defines the layout of a display could be used.

Although the previous embodiments have been described in which a plurality of databases (130a-130n) are stored in the mass data storage system (13), each of the databases being dedicated to a specific type of commodity, it will be appreciated that all the records (1000) could be stored in a single database with the product details which are not relevant for certain types of commodity being left blank in the records concerning those commodities.

Although, in the previous embodiments, the databases

have been described as stored on a single mass data storage system (13), it will be appreciated that the databases (130a-130n) could be present at different locations and the network trading system could send
5 queries interrogating a particular database to wherever the database was located.

CLAIMS:

1. A networked computer trading system comprising a central server station comprising:

5 means for receiving and transmitting data to and from a plurality of user stations and a data storage system; and

a plurality of user stations arranged to receive and transmit data to and from said central server station,

10 characterised by said system having stored therein a main input interface for inputting a selection of a type of commodity to be traded and a plurality of commodity interfaces for inputting product details of specific commodities, wherein each of said plurality of
15 commodity interfaces is arranged to enable the input of data relating to a respective different one of a plurality of commodities,

said system further comprising:

20 means for transmitting, in response to a request received from a said user station, said main input interface; and

means for transmitting one of said commodity interface, in response to a request received from a said user station using said main input interface.

25

2. A central server station for use in a networked computer trading system comprising:

means for receiving and transmitting data to and from a plurality of user stations; and

a data storage system;

characterised by:

5 said data storage system having stored therein a main input interface for inputting a selection of a type of commodity to be traded and a plurality of commodity interfaces for inputting product details of specific commodities, wherein each of said plurality of commodity
10 interfaces is arranged to enable the input of data relating to a respective different one of a plurality of commodities;

means for transmitting, in response to a request received from a said user station, said main input
15 interface; and

means for transmitting one of said commodity interfaces, in response to a request received from a said user station using said main input interface.

20 3. A system in accordance with claim 1 or 2, wherein said data storage system is arranged to store a database of commodities, each of said plurality of commodity interfaces defines a respective different input interface for inputting a query to interrogate said database, and
25 said means for receiving and transmitting data is arranged to transmit to a user station data based on the results of an interrogation of said database.

4. A system in accordance with claim 3, wherein said data storage system has stored therein a database of commodities.

5 5. A system in accordance with claim 3 or 4, wherein said database comprises a plurality of databases, each arranged to contain records relating to a respective different one of said plurality of commodities which can be selected using the main interface, wherein each of
10 said plurality of commodity interfaces defines a specific input interface for interrogating a respective different one of said plurality of databases.

6. A system in accordance with claim 3, 4 or 5, wherein
15 said data storage system has stored therein a plurality of output formats for outputting the results of an interrogation of said database, and said apparatus further comprises means for supplying output data to a user station using one of said plurality of output
20 templates and the results of interrogating said database.

7. A system in accordance with claim 6, wherein said data storage system has stored therein linking data representative of instructions for linking a user station
25 to a second user station, wherein said means for supplying output data is arranged to incorporate said linking data in said output data in accordance with the

results of an interrogation of said database.

8. A system in accordance with any of claims 3-7,
further comprising means for recording the number of
5 times individual records are retrieved from said
database.

9. A system according to claim 8, wherein said database
includes data representative of the value of products
10 stored therein, wherein said means for recording a number
of times entries are retrieved from said database is
arranged to record the accumulative value of the records
retrieved.

15 10. A system in accordance with claim 8 or 9, further
comprising output means for outputting said recorded
data.

11. A system in accordance with any of claims 3-10,
20 wherein said means for receiving and transmitting data
to and from a plurality of user stations is arranged to
receive data representative of records which are to be
stored in said database.

25 12. A system according to any of claims 3-11, further
comprising input means for inputting data for storage in
said database.

13. A network computer trading system comprising a central server station in accordance with any of claims 2-12 when dependent directly or indirectly upon claim 2 and a plurality of user stations, wherein said plurality
5 of user stations are arranged to receive and transmit data to and from said central server station.

14. A central server station for use in a networked computer trading system comprising:

10 means for receiving and transmitting data to and from a plurality of user stations; and

a data storage system;

characterised in that:

said data storage system has stored therein a main
15 input interface template defining an interface for selecting a type of commodity to be traded and a plurality of commodity interface templates each defining an input interface for inputting product details of specific commodities, wherein each of said plurality of
20 commodity interface templates is arranged to enable input of data relating to a respective different one of the plurality of commodities which can be selected using the main interface defined by the main interface template.

25 15. A storage medium having stored therein instructions for generating in a computer a main input interface template defining an interface for selecting a type of

commodity to be traded and a plurality of commodity interface templates each defining an input interface for inputting product details of specific commodities, wherein each of said plurality of commodity interface
5 templates is arranged to enable input of data relating to a respective different one of the plurality of commodities which can be selected using the main interface defined by the main interface template.

1/17

FIG. 1

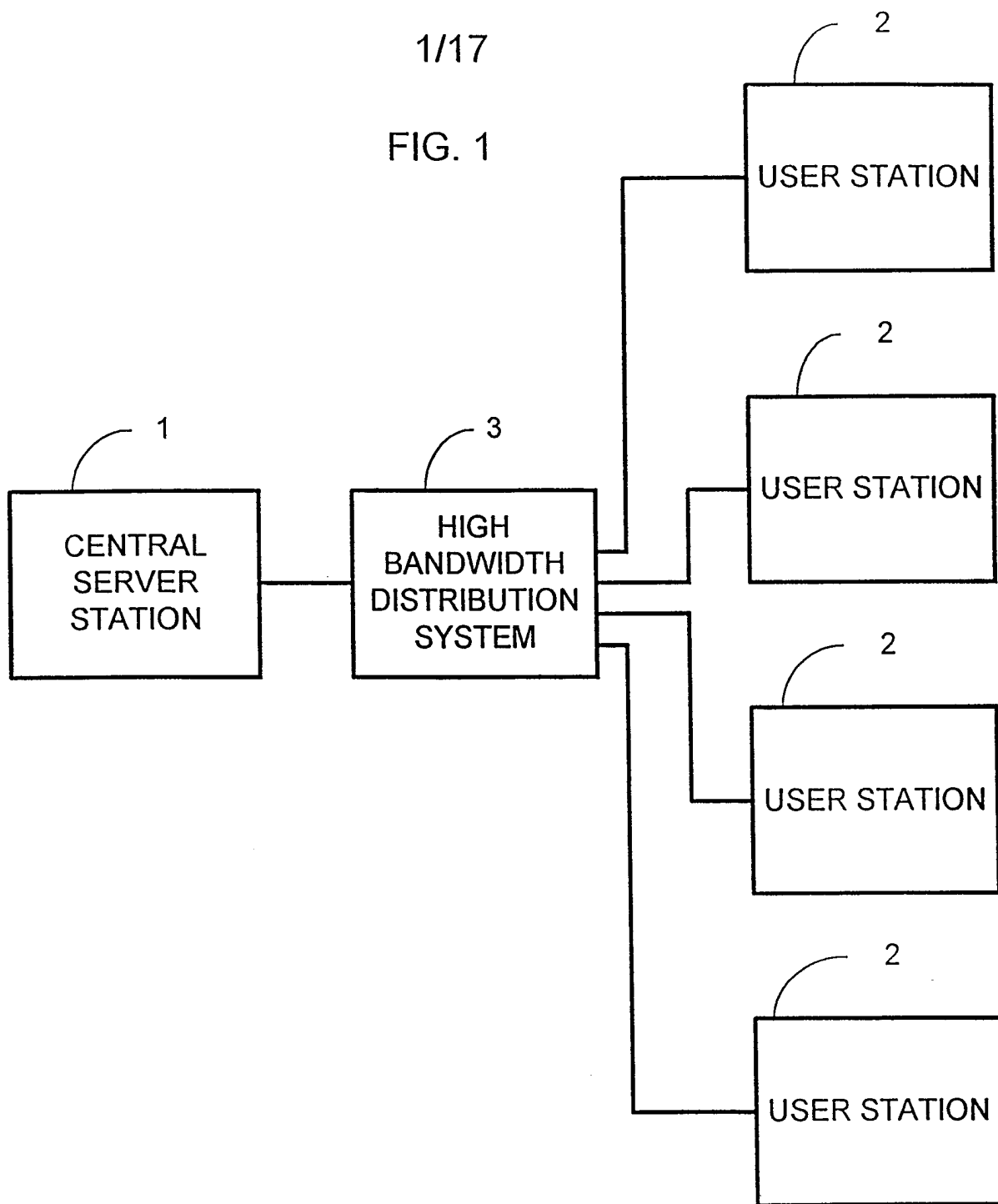

2/17

FIG. 2

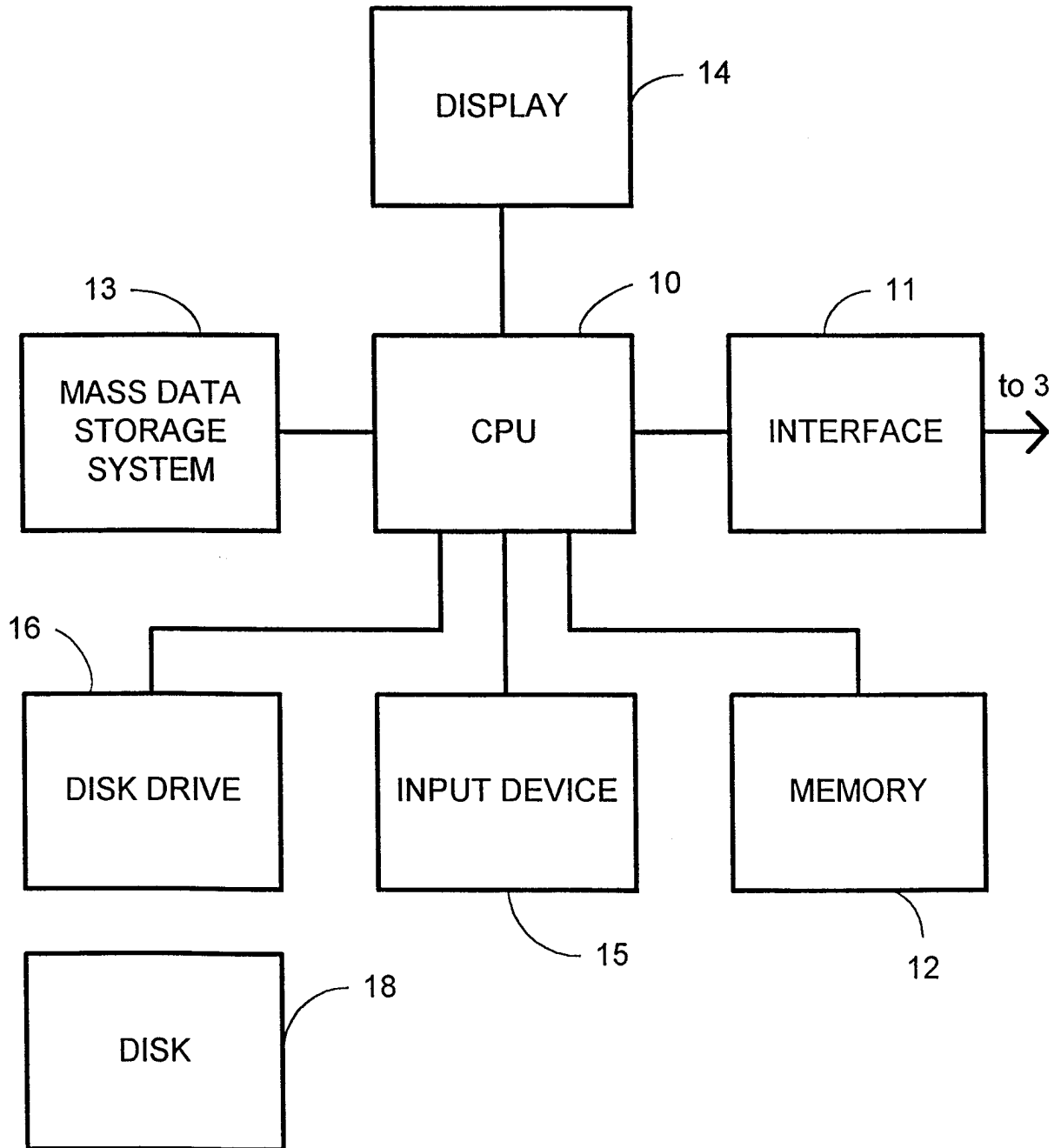

3/17

FIG.3

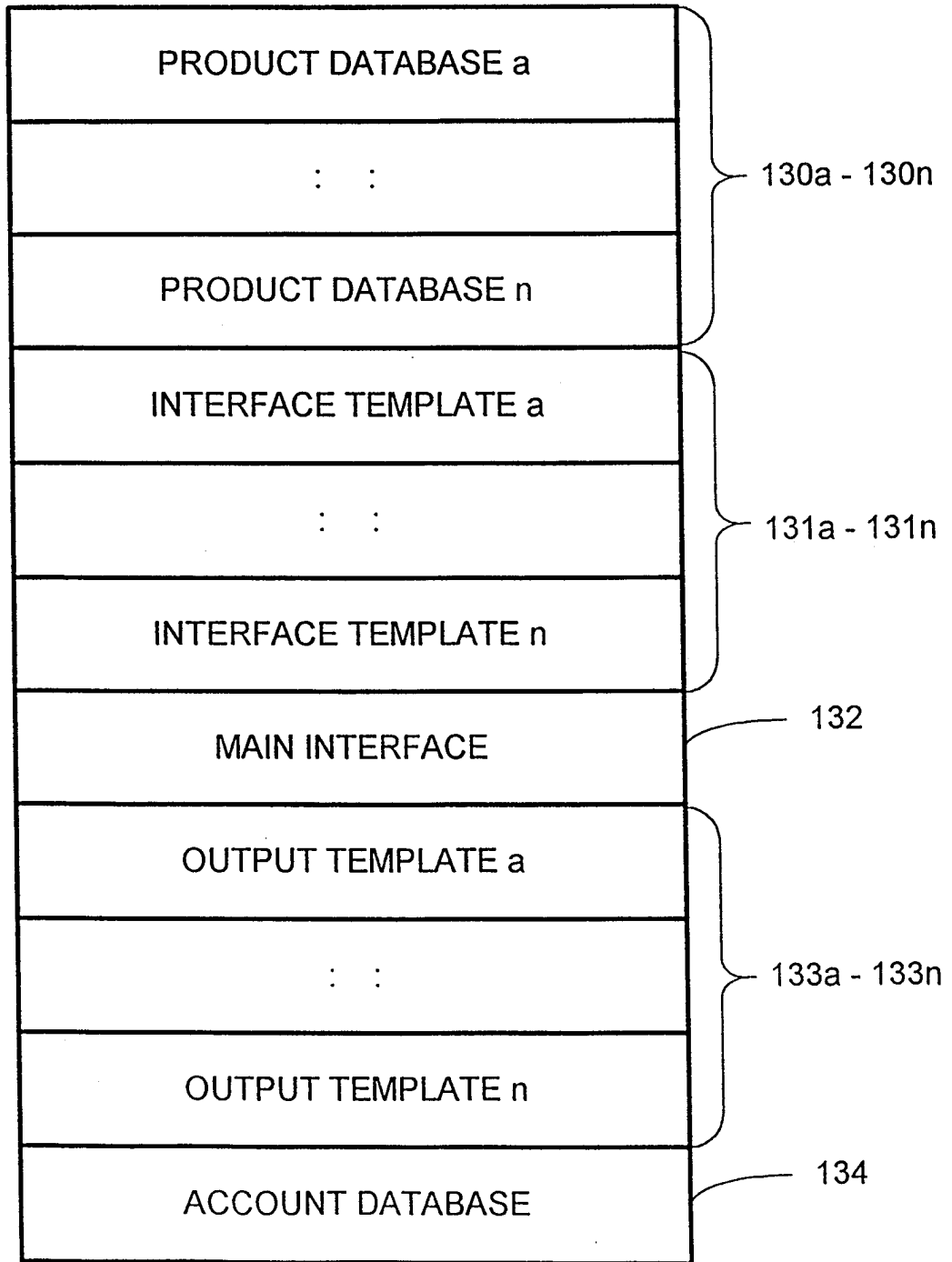

4/17

FIG.4

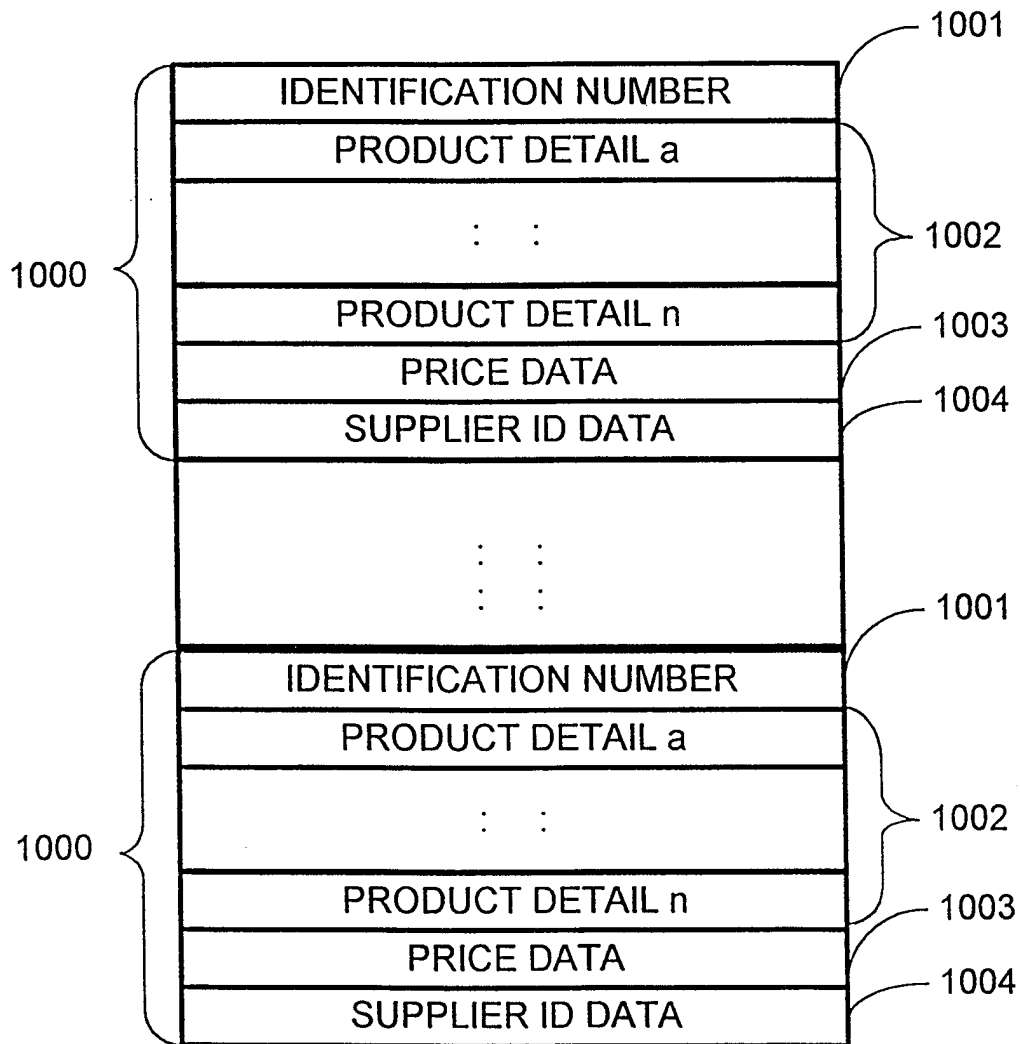

5/17

FIG.5

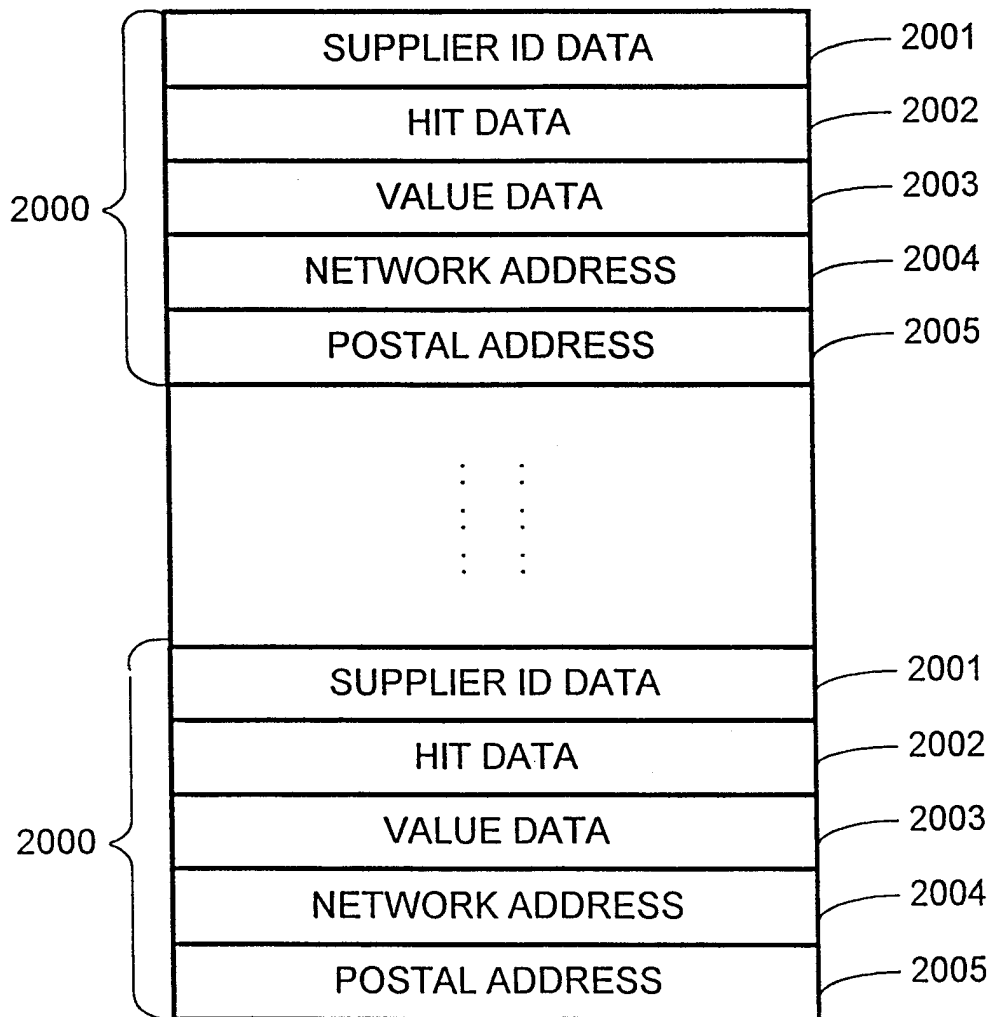

6/17

FIG. 6

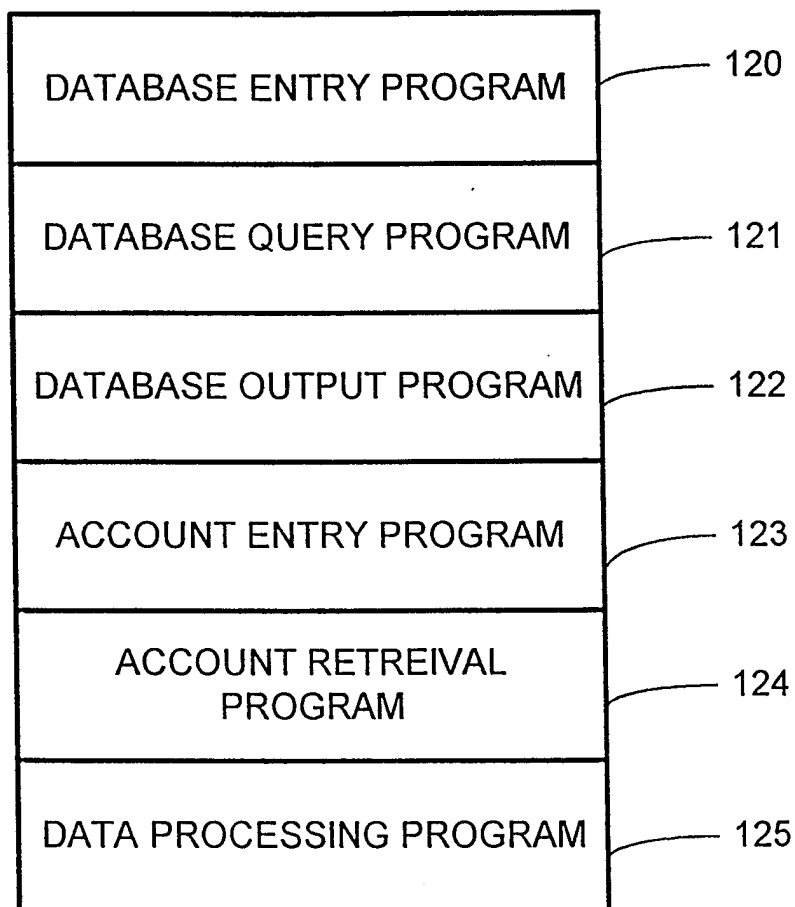

7/17

FIG. 7

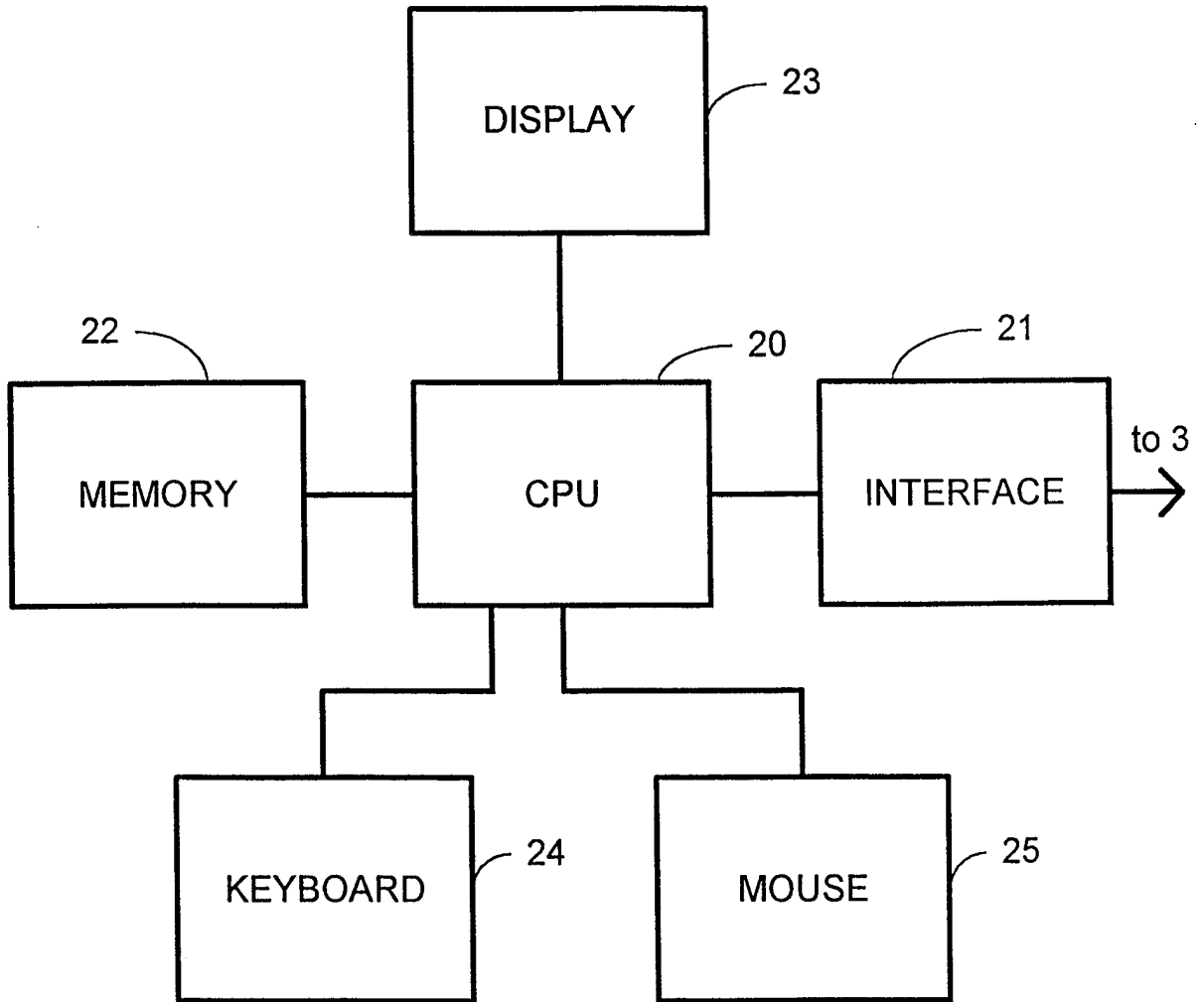

8/17

FIG.8A

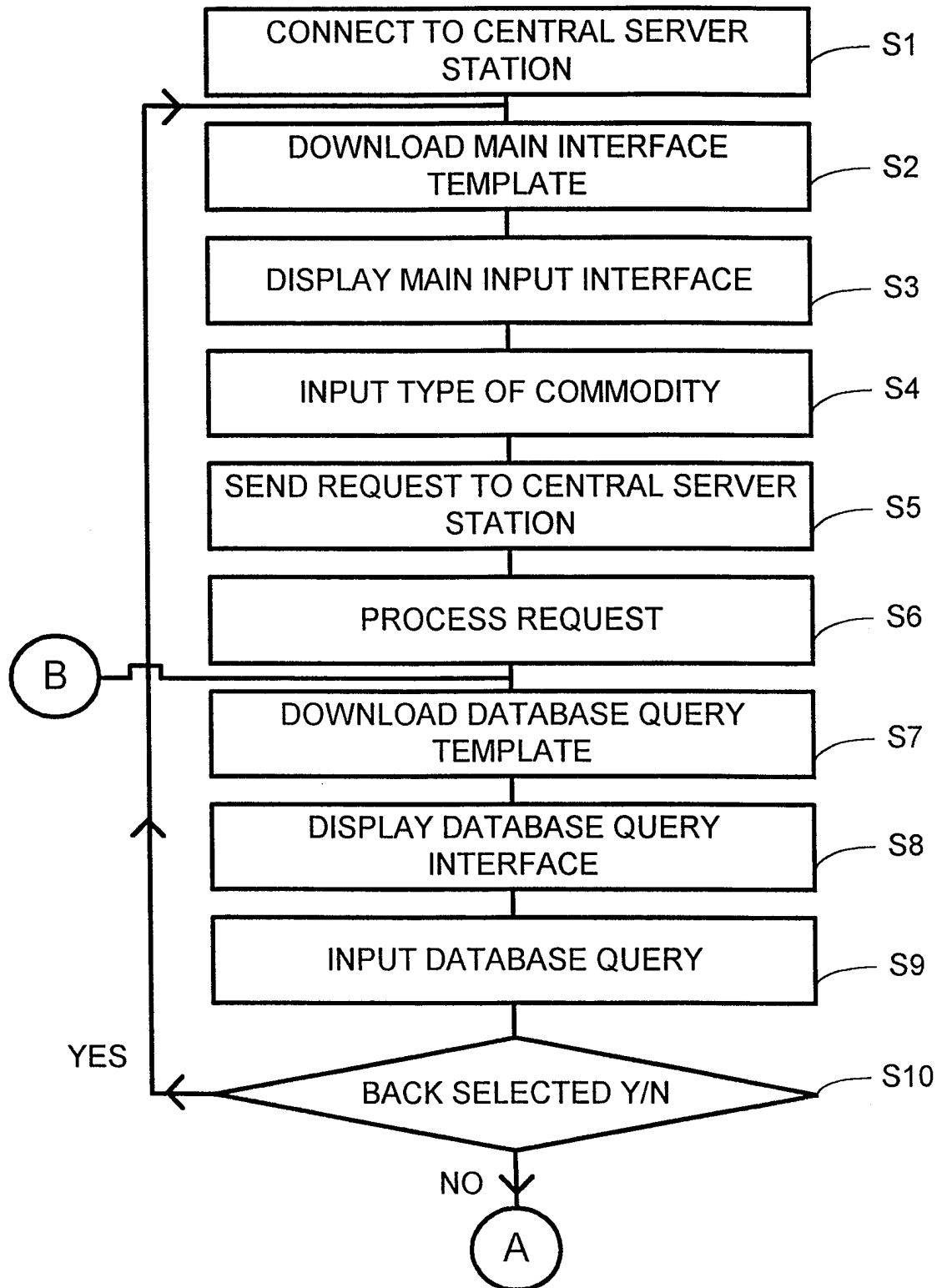

9/17

FIG.8B

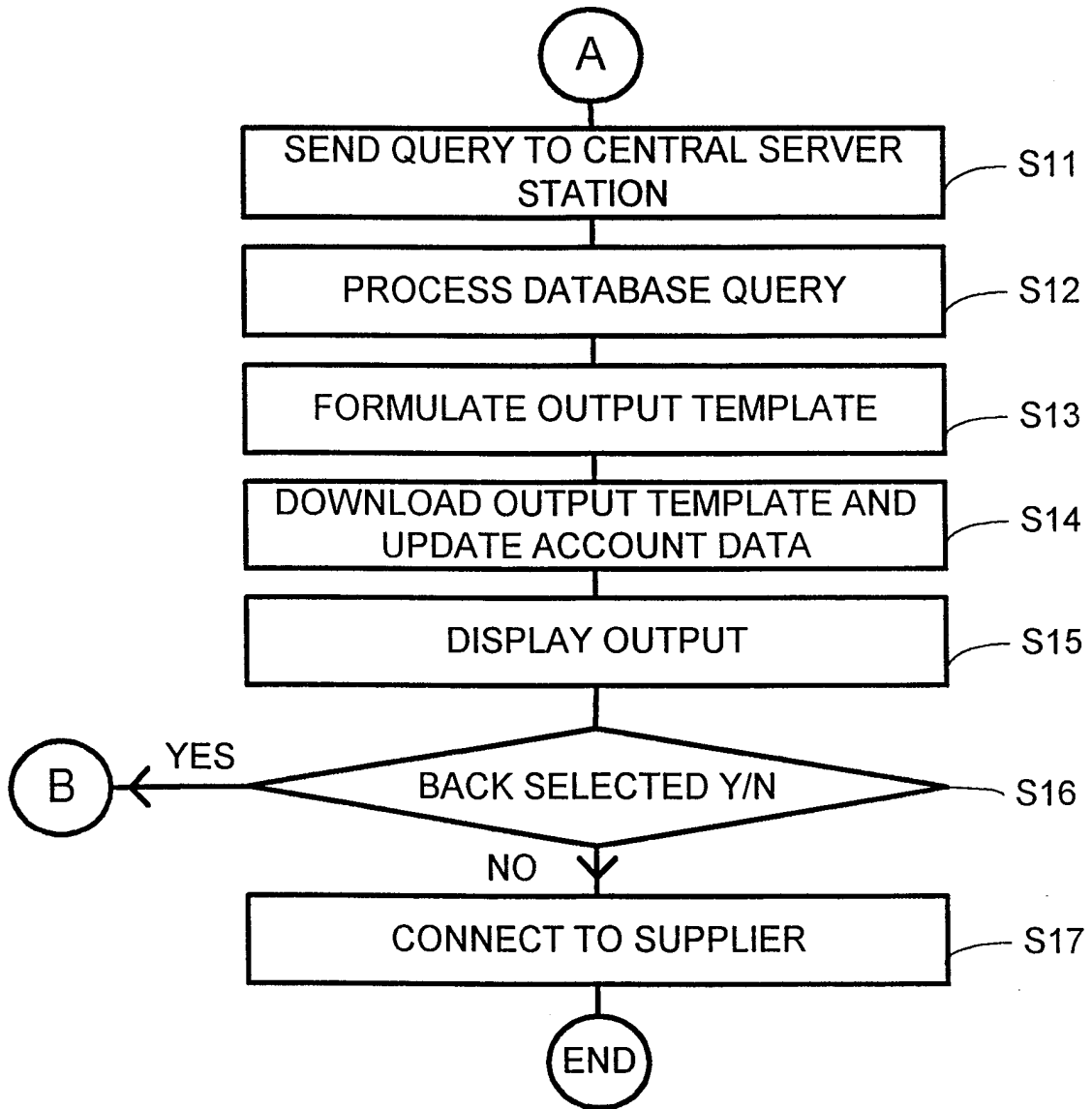

10/17

FIG.9

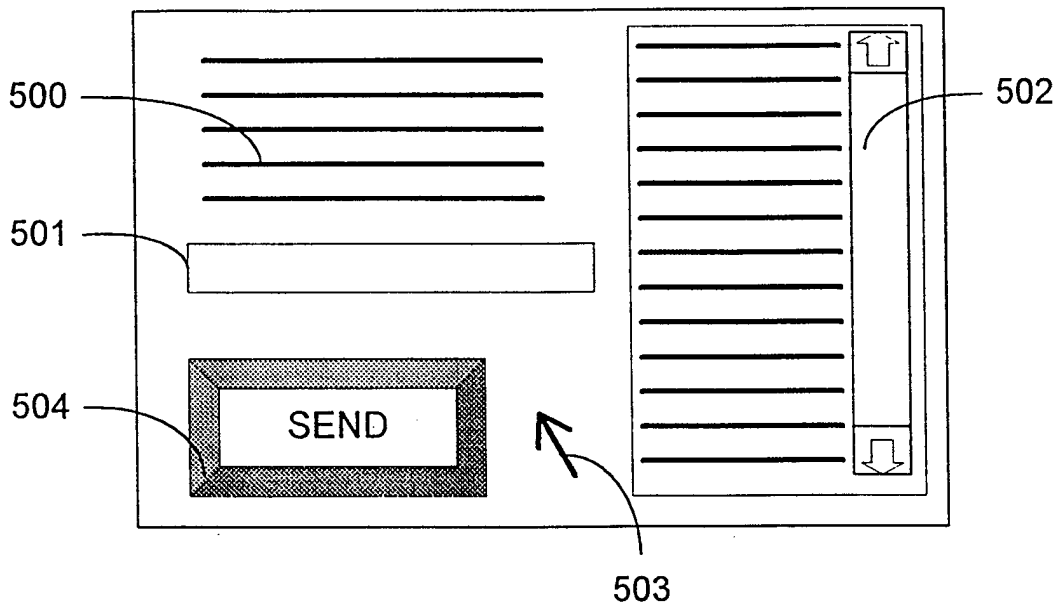

FIG.10

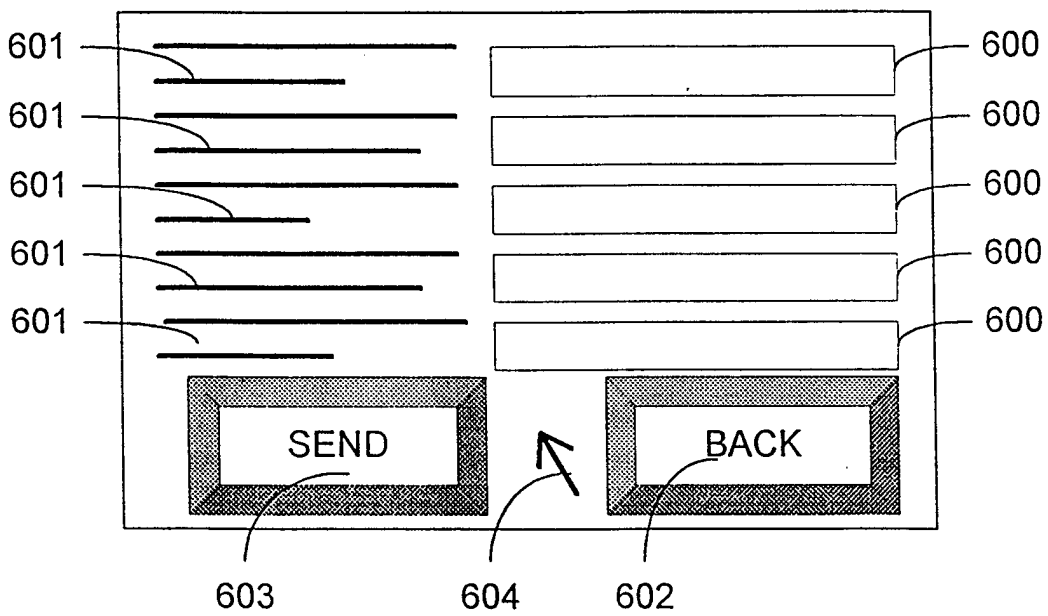
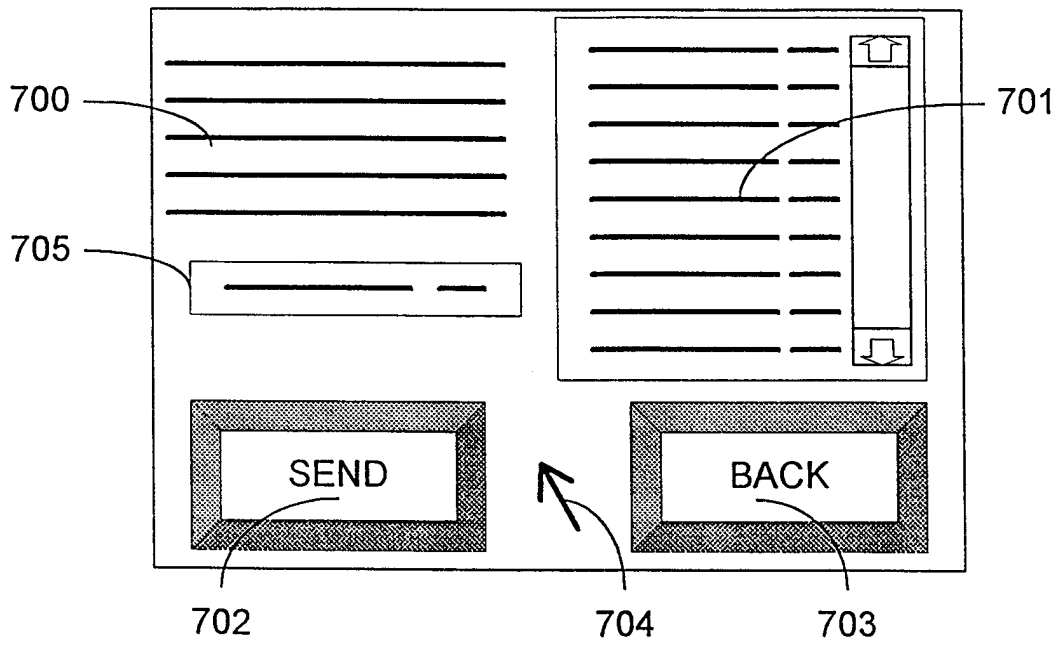
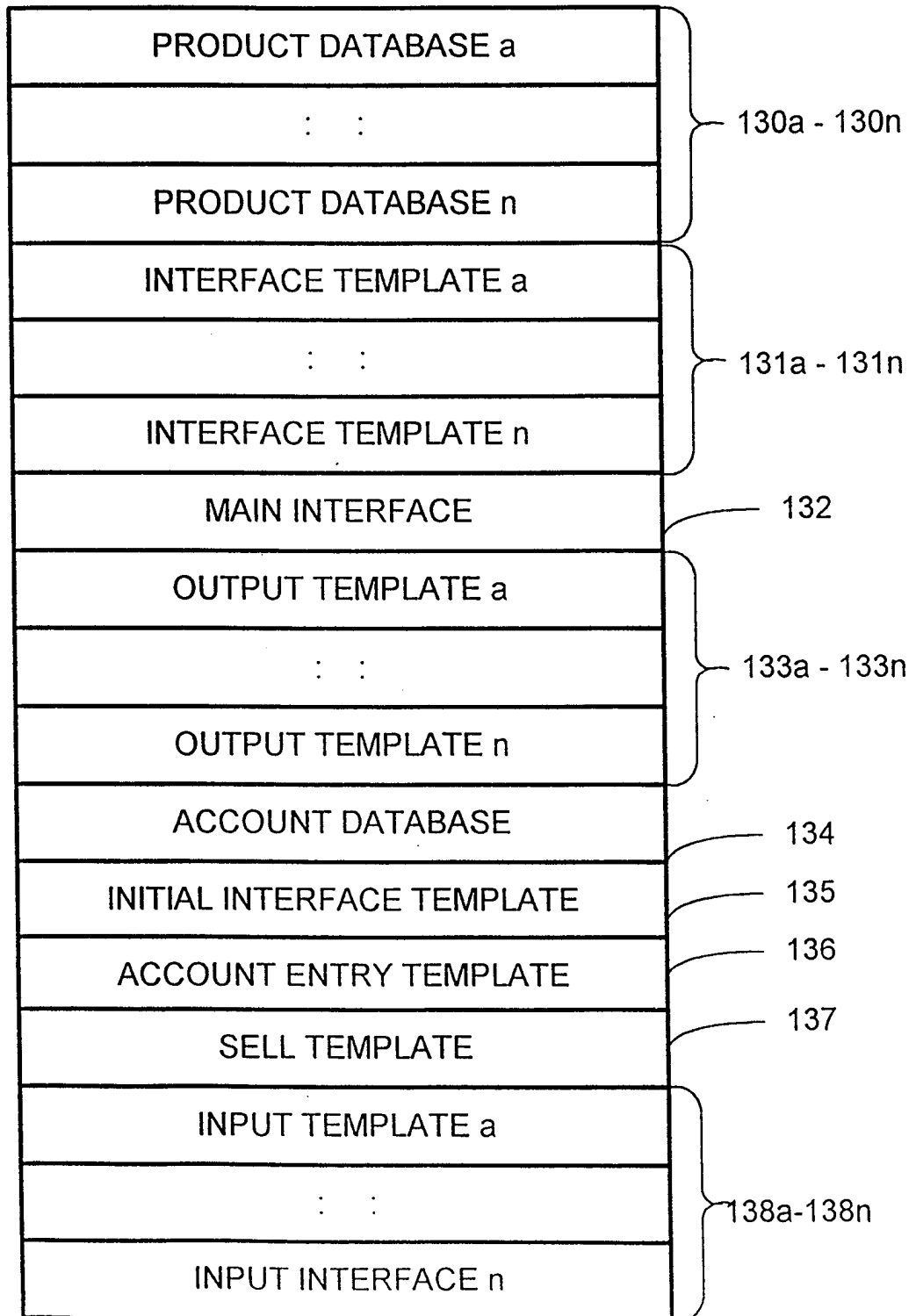

FIG.11



12/17

FIG.12



13/17

FIG. 13

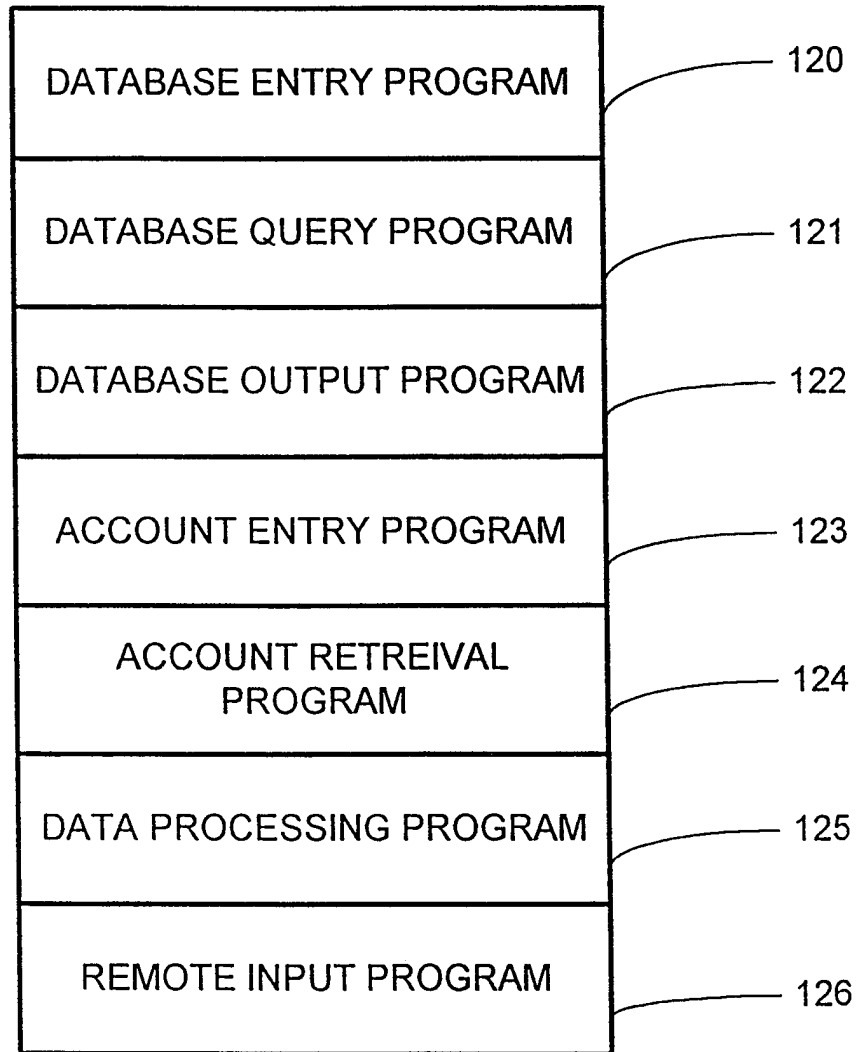

14/17
FIG. 14A

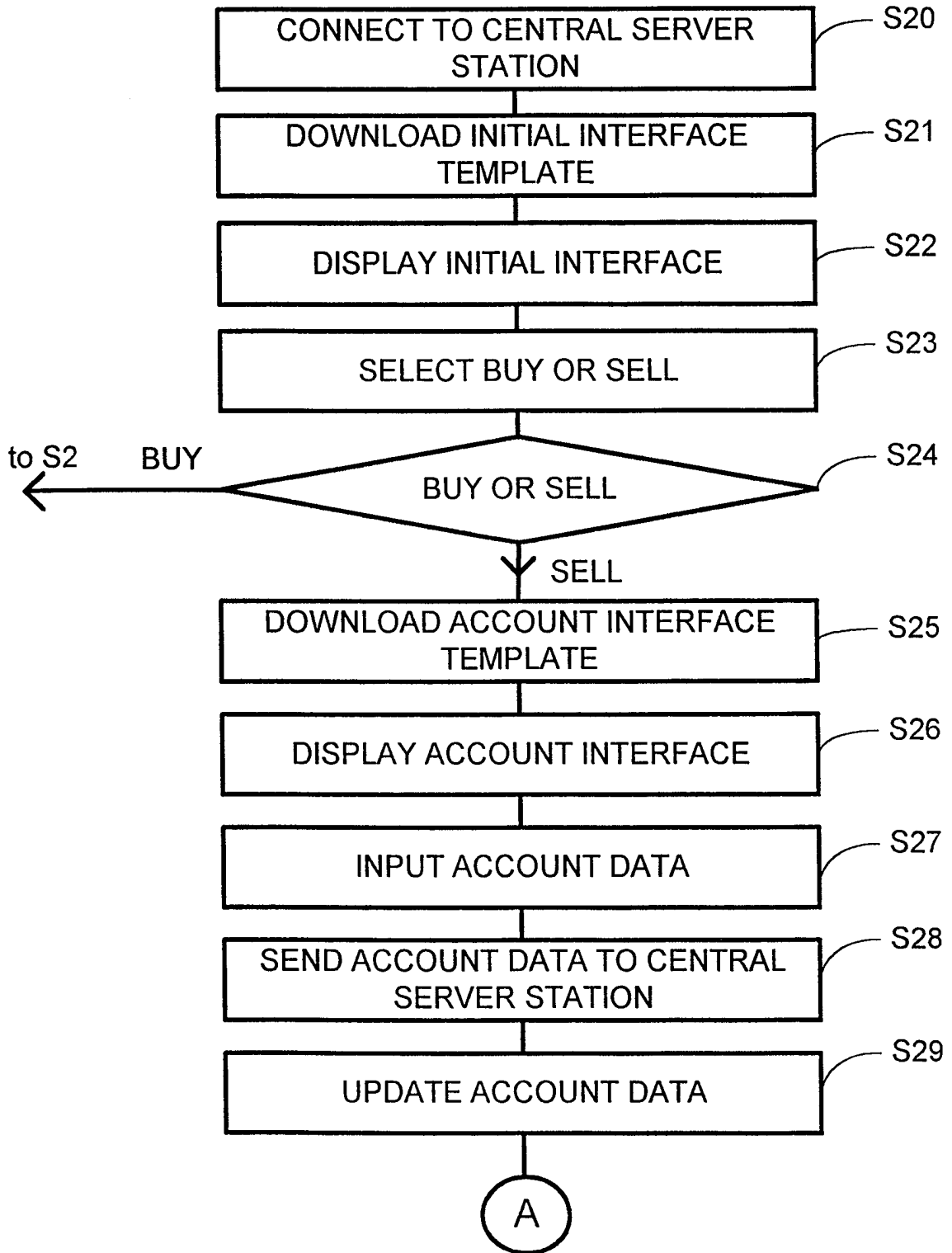

15/17
FIG. 14B

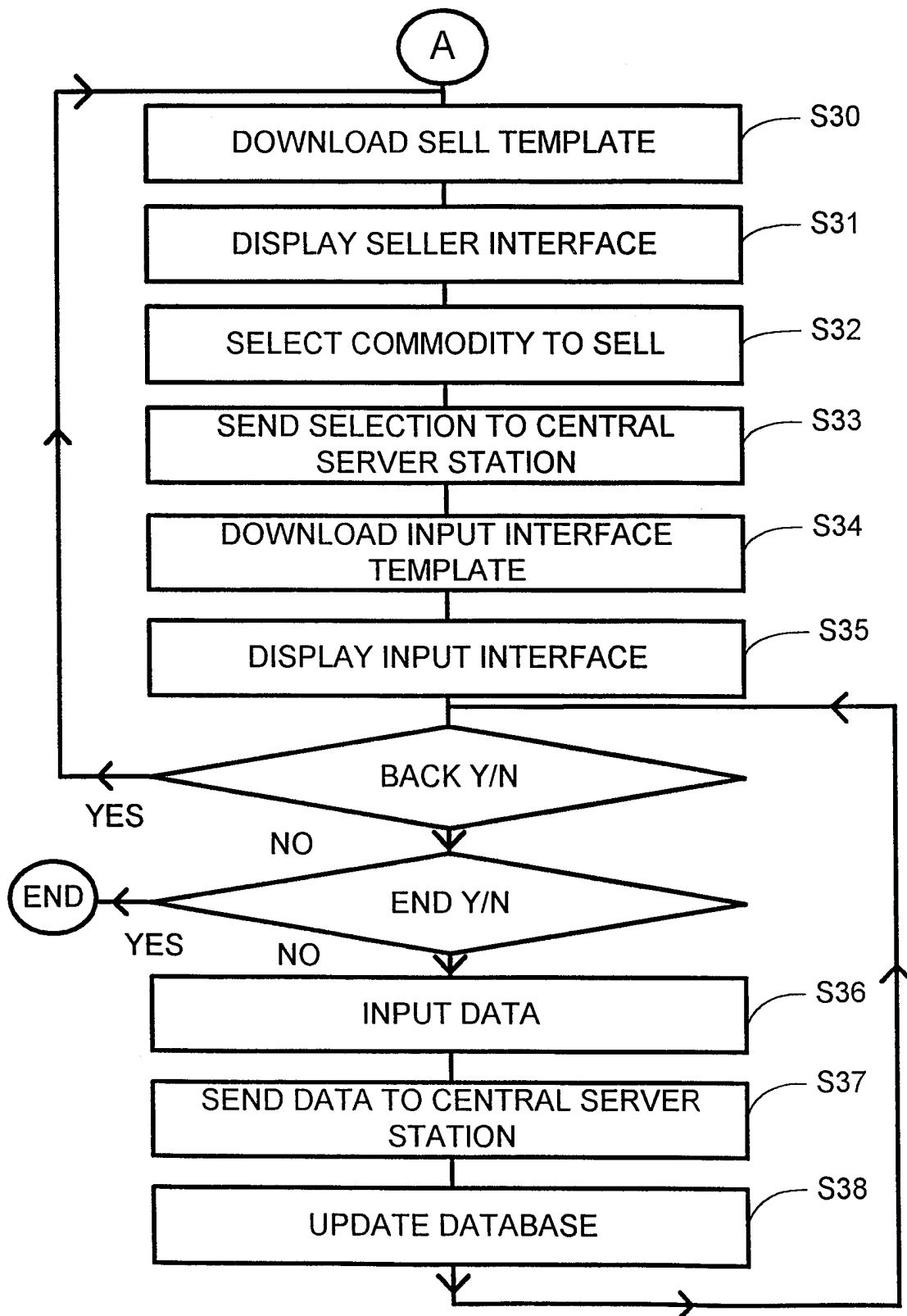

16/17

FIG.15

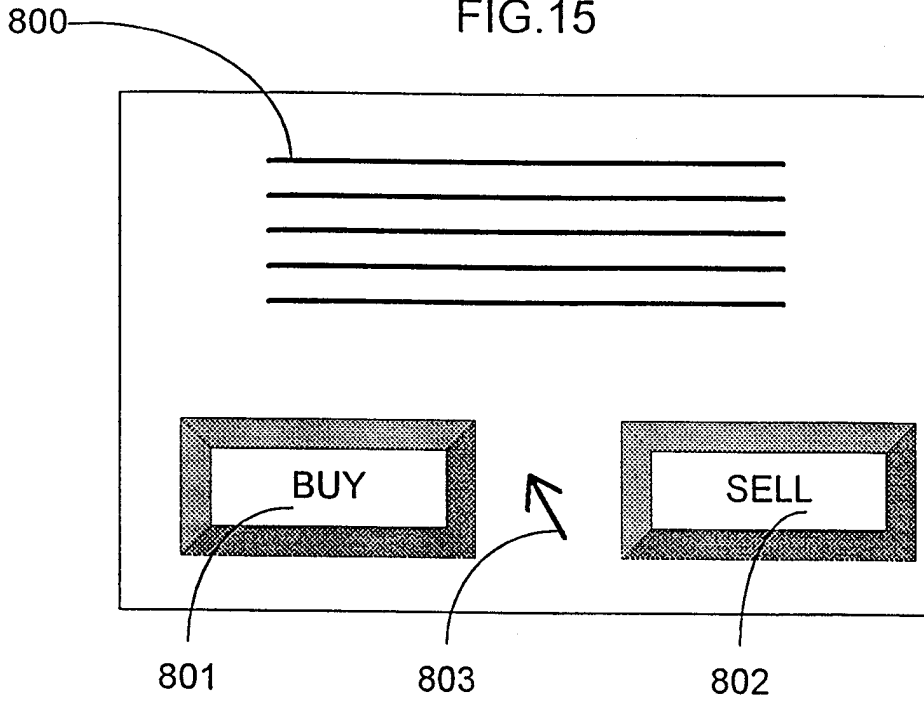
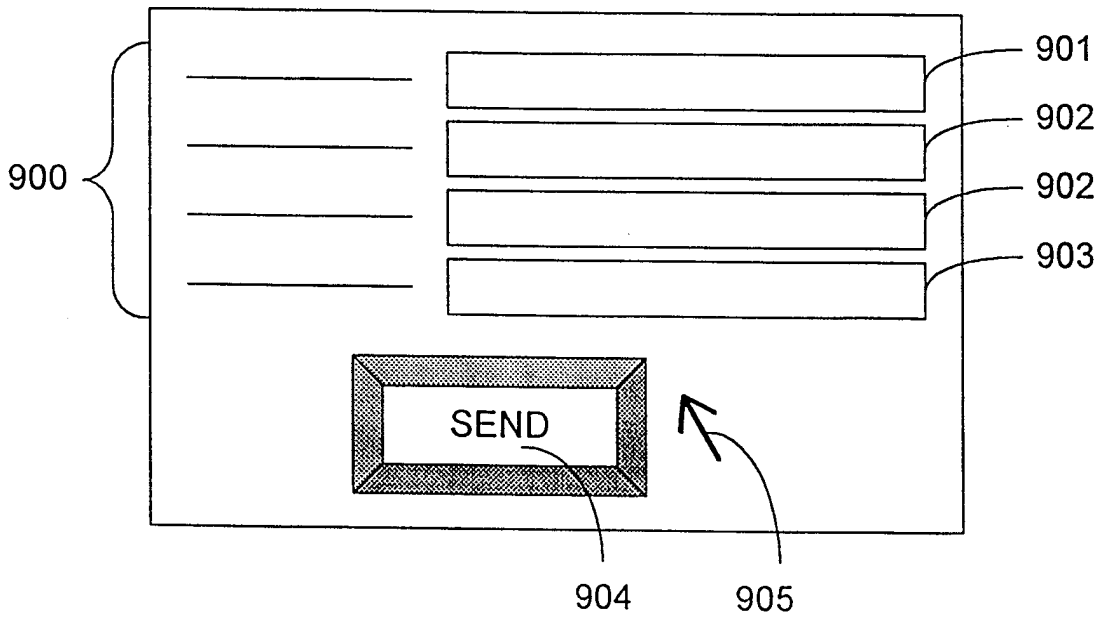

FIG.16



17/17

FIG.17

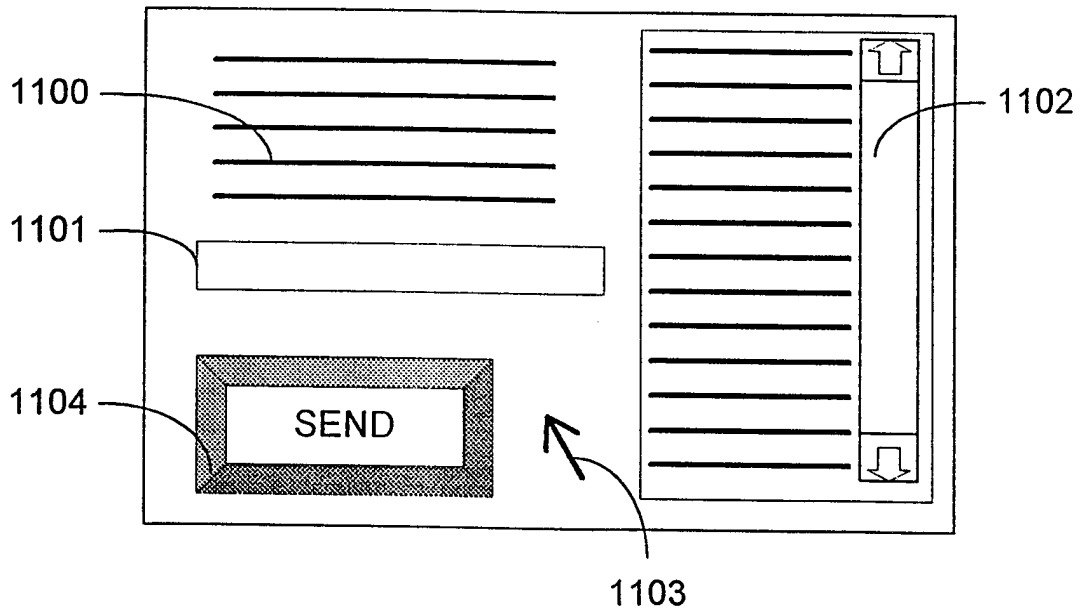
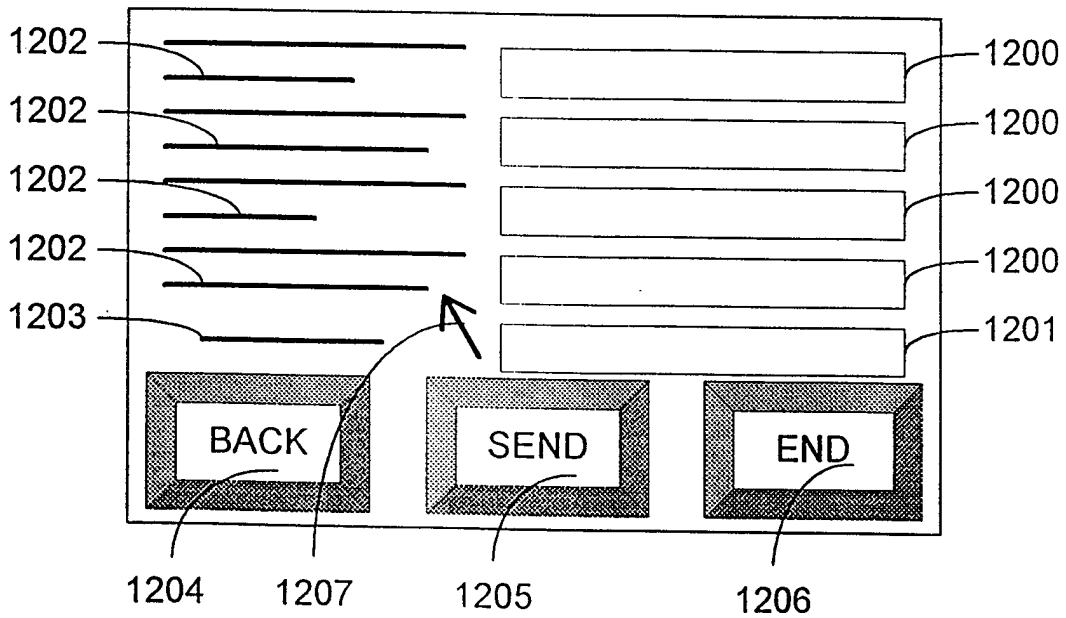

FIG.18



INTERNATIONAL SEARCH REPORT

International Application No

PCT/GB 98/01240

A. CLASSIFICATION OF SUBJECT MATTER
IPC 6 G06F17/60

According to International Patent Classification (IPC) or to both national classification and IPC

B. FIELDS SEARCHED

Minimum documentation searched (classification system followed by classification symbols)
IPC 6 G06F

Documentation searched other than minimum documentation to the extent that such documents are included in the fields searched

Electronic data base consulted during the international search (name of data base and, where practical, search terms used)

C. DOCUMENTS CONSIDERED TO BE RELEVANT

Category °	Citation of document, with indication, where appropriate, of the relevant passages	Relevant to claim No.
A	US 5 592 375 A (SALMON BARDWELL C ET AL) 7 January 1997 see column 1, line 25 - line 38 see column 2, line 15 - line 24 see column 14, line 2 - column 15, line 21 ---	1, 2, 14, 15
A	US 5 592 378 A (CAMERON PAUL S ET AL) 7 January 1997 see abstract; claim 1 see column 13, line 41 - column 18, line 8; figures 17-26 ---	1, 2, 14, 15
A	EP 0 706 124 A (SONY TRANS COM INC) 10 April 1996 see abstract; claim 1 -----	1, 2, 14, 15

Further documents are listed in the continuation of box C.

Patent family members are listed in annex.

° Special categories of cited documents :

- "A" document defining the general state of the art which is not considered to be of particular relevance
- "E" earlier document but published on or after the international filing date
- "L" document which may throw doubts on priority claim(s) or which is cited to establish the publication date of another citation or other special reason (as specified)
- "O" document referring to an oral disclosure, use, exhibition or other means
- "P" document published prior to the international filing date but later than the priority date claimed

- "T" later document published after the international filing date or priority date and not in conflict with the application but cited to understand the principle or theory underlying the invention
- "X" document of particular relevance; the claimed invention cannot be considered novel or cannot be considered to involve an inventive step when the document is taken alone
- "Y" document of particular relevance; the claimed invention cannot be considered to involve an inventive step when the document is combined with one or more other such documents, such combination being obvious to a person skilled in the art.
- "&" document member of the same patent family

Date of the actual completion of the international search

12 August 1998

Date of mailing of the international search report

20/08/1998

Name and mailing address of the ISA

European Patent Office, P.B. 5818 Patentlaan 2
NL - 2280 HV Rijswijk
Tel. (+31-70) 340-2040, Tx. 31 651 epo nl,
Fax: (+31-70) 340-3016

Authorized officer

Suendermann, R

INTERNATIONAL SEARCH REPORT

information on patent family members

International Application No

PCT/GB 98/01240

Patent document cited in search report	Publication date	Patent family member(s)	Publication date
US 5592375 A	07-01-1997	AU 1996695 A WO 9524687 A	25-09-1995 14-09-1995
US 5592378 A	07-01-1997	NONE	
EP 0706124 A	10-04-1996	US 5675752 A JP 8194608 A	07-10-1997 30-07-1996