

**(12) STANDARD PATENT**  
**(19) AUSTRALIAN PATENT OFFICE**

(11) Application No. **AU 2012333210 B2**

(54) Title  
**Reduced-pressure dressings employing tissue-fixation elements**

(51) International Patent Classification(s)  
**A61F 13/00** (2006.01)                      **A61M 1/00** (2006.01)  
**A61F 13/02** (2006.01)

(21) Application No: **2012333210**                      (22) Date of Filing: **2012.06.25**

(87) WIPO No: **WO13/066426**

(30) Priority Data

(31) Number	(32) Date	(33) Country
<b>61/500,915</b>	<b>2011.06.24</b>	<b>US</b>

(43) Publication Date: **2013.05.10**

(44) Accepted Journal Date: **2017.01.19**

(71) Applicant(s)  
**KCI Licensing, Inc.**

(72) Inventor(s)  
**Robinson, Timothy Mark; Simmons, Tyler; Hall, Colin John; Losole, Jeanette**

(74) Agent / Attorney  
**Shelston IP Pty Ltd., Level 21, 60 Margaret Street, Sydney, NSW, 2000**

(56) Related Art  
**WO 2011/028407 A1**  
**US 2010/0069850 A1**  
**US 2011/0118683 A1**



(51) International Patent Classification:

A61F 13/02 (2006.01) A61M 1/00 (2006.01)  
A61F 13/00 (2006.01)

(21) International Application Number:

PCT/US2012/044007

(22) International Filing Date:

25 June 2012 (25.06.2012)

(25) Filing Language:

English

(26) Publication Language:

English

(30) Priority Data:

61/500,915 24 June 2011 (24.06.2011) US

(71) Applicant (for all designated States except US): **KCI LICENSING, INC.** [US/US]; Legal Department - Intellectual Property, P.O. Box 659508, San Antonio, TX 78265-9508 (US).

(72) Inventors; and

(75) Inventors/Applicants (for US only): **ROBINSON, Timothy, Mark** [GB/GB]; 27 Wellington Terrace, Basingstoke, Hampshire RG23 8HH (GB). **SIMMONS, Tyler** [US/US]; 25812 Stone Canyon, San Antonio, TX 78260 (US). **HALL, Colin, John** [GB/GB]; 33 Oakdale Road, Poole, Dorset BH15 3LD (GB). **LOSOLE, Jeanette** [US/US]; 2223 Oak Bend, San Antonio, TX 78259 (US).

(74) Agents: **WELCH, Gerald** et al.; SNR Denton US LLP, P.O. Box 061080, Wacker Drive Station, Willis Tower, Chicago, IL 60606 (US).

(81) Designated States (unless otherwise indicated, for every kind of national protection available):

AE, AG, AL, AM, AO, AT, AU, AZ, BA, BB, BG, BH, BR, BW, BY, BZ, CA, CH, CL, CN, CO, CR, CU, CZ, DE, DK, DM, DO, DZ, EC, EE, EG, ES, FI, GB, GD, GE, GH, GM, GT, HN, HR, HU, ID, IL, IN, IS, JP, KE, KG, KM, KN, KP, KR, KZ, LA, LC, LK, LR, LS, LT, LU, LY, MA, MD, ME, MG, MK, MN, MW, MX, MY, MZ, NA, NG, NI, NO, NZ, OM, PE, PG, PH, PL, PT, QA, RO, RS, RU, RW, SC, SD, SE, SG, SK, SL, SM, ST, SV, SY, TH, TJ, TM, TN, TR, TT, TZ, UA, UG, US, UZ, VC, VN, ZA, ZM, ZW.

(84) Designated States (unless otherwise indicated, for every kind of regional protection available):

ARIPO (BW, GH, GM, KE, LR, LS, MW, MZ, NA, RW, SD, SL, SZ, TZ, UG, ZM, ZW), Eurasian (AM, AZ, BY, KG, KZ, RU, TJ, TM), European (AL, AT, BE, BG, CH, CY, CZ, DE, DK, EE, ES, FI, FR, GB, GR, HR, HU, IE, IS, IT, LT, LU, LV, MC, MK, MT, NL, NO, PL, PT, RO, RS, SE, SI, SK, SM, TR), OAPI (BF, BJ, CF, CG, CI, CM, GA, GN, GQ, GW, ML, MR, NE, SN, TD, TG).

Published:

— with international search report (Art. 21(3))

[Continued on next page]

(54) Title: REDUCED-PRESSURE DRESSINGS EMPLOYING TISSUE-FIXATION ELEMENTS

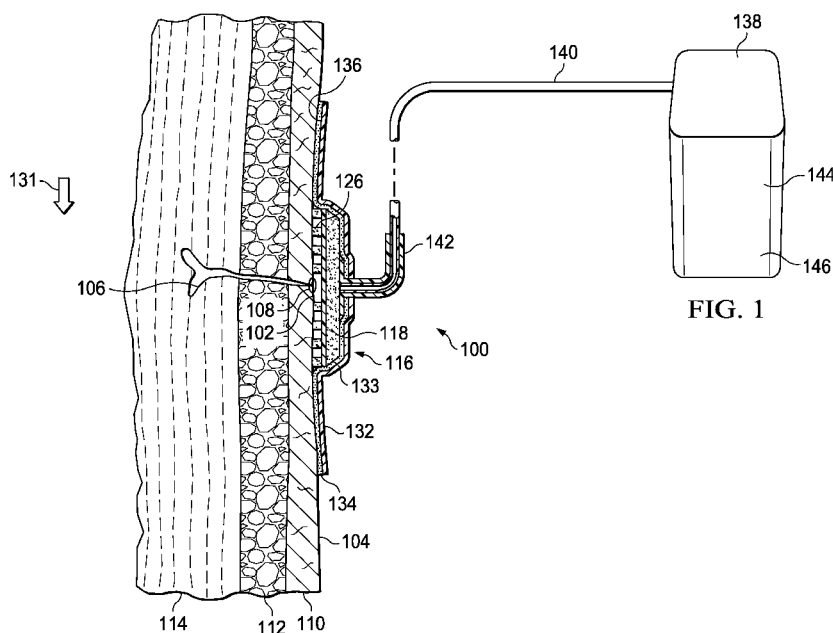

FIG. 1

(57) Abstract: A reduced-pressure system for treating a tissue site on a patient includes a distribution manifold that adheres to a tissue site to allow retention without external support. The distribution manifold includes a porous member and a tissue-fixation element. The tissue-fixation element maintains the porous member substantially adjacent to the tissue site while a sealing member is applied. In one instance, the tissue-fixation element is a soluble adhesive that partially covers either the tissue-facing side of the porous member or a tissue-facing side of a fluid-permeable substrate layer that is on the tissue-facing side of the porous member. Other systems, distributions manifolds, and methods are presented.





---

— *before the expiration of the time limit for amending the claims and to be republished in the event of receipt of amendments (Rule 48.2(h))*

**(88) Date of publication of the international search report:**  
6 September 2013

**REDUCED-PRESSURE DRESSINGS EMPLOYING TISSUE-FIXATION ELEMENTS**

**RELATED APPLICATIONS**

5 [0001] This application claims the benefit of the filing of U.S. Provisional Patent Application serial number 61/500,915, entitled “Reduced-Pressure Dressings Employing Tissue-Fixation Elements,” filed June 24, 2011, which is incorporated herein by reference for all purposes.

**BACKGROUND**

10 [0002] The present disclosure relates generally to medical treatment systems and, more particularly, but not by way of limitation, to reduced-pressure dressings employing a tissue-fixation element.

15 [0003] Clinical studies and practice have shown that providing a reduced pressure in proximity to a tissue site augments and accelerates the growth of new tissue at the tissue site. The applications of this phenomenon are numerous, but application of reduced pressure has been particularly successful in treating wounds. This treatment (frequently referred to in the medical community as “negative pressure wound therapy,” “reduced pressure therapy,” or “vacuum therapy”) provides a number of benefits, which may include faster healing and increased formulation of granulation tissue. Typically, reduced pressure is applied to tissue through a porous pad or other manifold device. The porous pad distributes reduced pressure to  
20 the tissue and channels fluids that are drawn from the tissue. Reduced pressure may also be applied for other treatments, such as removing fluids.

## SUMMARY

[0004] According to one aspect of the invention, there is provided a reduced-pressure system for treating a tissue site, the system comprising: a distribution manifold comprising: a porous member having a plurality of flow channels for distributing reduced pressure and receiving fluids, the porous member having a first side and a second, tissue-facing side, a fluid-permeable substrate member having a first side and a second, tissue-facing side, wherein the second, tissue-facing side of the porous member is proximate to the first side of the fluid-permeable substrate member, and wherein the second, tissue-facing side of the fluid-permeable substrate member has a surface area  $A_s$ , and a tissue-fixation element having a first side and a second, tissue-facing side, and wherein the first side of the tissue-fixation element is coupled to the second, tissue-facing side of the fluid-permeable substrate member, wherein the second, tissue-facing side of the tissue-fixation element has a surface area  $A_t$ , and wherein  $0.05A_s < A_t < 0.7A_s$ ; a sealing member for disposing over the distribution manifold to create a sealed space containing the distribution manifold; a reduced-pressure source fluidly coupled to the sealed space for providing reduced pressure to the sealed space; and a liquid receptor fluidly coupled to distribution manifold for receiving fluids from the patient under the influence of reduced pressure from the reduced-pressure source.

[0005] According to another aspect of the invention, there is provided a method for treating a tissue site on a patient with reduced pressure, the method comprising the steps of: tacking a distribution manifold to the tissue site using a tissue-fixation element on the distribution manifold so that the distribution manifold remains substantially adjacent to the tissue site; wherein the distribution manifold comprises: a porous member for distributing reduced pressure and receiving fluid, the porous member having surface area  $A_p$  facing the tissue site, and a tissue-fixation element coupled to the porous member, wherein the tissue-fixation element has a surface area  $A_t$  facing the tissue site, and wherein  $0.05A_p < A_t < 0.6A_p$ ; covering the distribution manifold with a sealing member to form a sealed space containing the distribution manifold; and providing reduced pressure to the sealed space.

5 [0006] According to another aspect of the invention, there is provided a method of treating a tissue site on a patient with reduced pressure, the method comprising the steps of: providing a tack unit; providing a distribution manifold comprising a porous member; disposing the tack unit against the tissue site; disposing the distribution manifold against the  
10 tack unit such that the distribution manifold remains adjacent to the tissue site without exterior support other than the tack unit and the tissue site; covering the distribution manifold with a sealing member to create a sealed space containing the distribution manifold; and providing reduced pressure to the distribution manifold.

10 [0007] According to another aspect of the invention, there is provided a distribution manifold for use in a reduced pressure system for providing reduced pressure to a tissue site on a patient, the distribution manifold comprising: a porous member having a plurality of flow channels for distributing reduced pressure and receiving fluids, the porous member having a first side and a second, tissue-facing side; a fluid-permeable substrate member having a first side and a second, tissue-facing side, wherein the second, tissue-facing side of the porous  
15 member is proximate to the first side of the fluid-permeable substrate member, and wherein the second, tissue-facing side of the fluid-permeable substrate member has a surface area  $A_s$ ; and a tissue-fixation element having a first side and a second, tissue-facing side, and wherein the first side of the tissue-fixation element is coupled to the second, tissue-facing side of the fluid-permeable substrate member, wherein the second, tissue-facing side of the tissue-fixation  
20 element has a surface area  $A_t$ , and wherein  $0.05A_s < A_t < 0.6A_s$ .

25 [0008] According to another aspect of the invention, there is provided a method of manufacturing a distribution manifold for use in a reduced-pressure system for providing reduced pressure to a tissue site on a patient, the method comprising the steps of: providing a porous member having a plurality of flow channels for distributing reduced pressure and receiving fluids, the porous member having a first side and a second, tissue-facing side;  
30 providing a fluid-permeable substrate member having a first side and a second, tissue-facing side, wherein the second, tissue-facing side of the fluid-permeable substrate member has a surface area  $A_s$ ; coupling the second, tissue-facing side of the porous member to the first side of the fluid-permeable substrate member; providing a tissue-fixation element having a first side and a second, tissue-facing side, and wherein the second, tissue-facing side of the tissue-fixation element has a surface area  $A_t$ , and wherein  $0.05A_s < A_t < 0.6A_s$ ; and coupling the first

side of the tissue-fixation element to the second, tissue-facing side of the fluid-permeable substrate member.

5 [0009] According to another aspect of the invention, there is provided a method of treating a tissue site on a patient with reduced pressure comprising the steps of: positioning the patient in a prevailing position, which is a position that the patient will remain for a majority of time during treatment; using a tissue-fixation element to tack a porous member to the tissue site while the patient remains in the prevailing position, wherein in the prevailing position the tissue site is substantially parallel to a gravitational field; covering the porous member with a sealing member to form a sealed space; and providing reduced pressure to the sealed space.

10 [0009A] Unless the context clearly requires otherwise, throughout the description and the claims, the words “comprise”, “comprising”, and the like are to be construed in an inclusive sense as opposed to an exclusive or exhaustive sense; that is to say, in the sense of “including, but not limited to”.

15 [0010] Other features and advantages of the illustrative embodiments will become apparent with reference to the drawings and detailed description that follow.

**BRIEF DESCRIPTION OF THE DRAWINGS**

[0011] FIGURE 1 is a schematic diagram with a portion shown in cross section of an illustrative embodiment of a reduced-pressure system for treating a tissue site;

[0012] FIGURE 2 is a schematic cross section of an illustrative embodiment of a distribution manifold;

[0013] FIGURE 3 is a schematic bottom (tissue-facing side) plan view of an illustrative embodiment of a porous member and a tissue-fixation element;

[0014] FIGURE 4 is a schematic bottom plan view of an illustrative embodiment of a porous member and a tissue-fixation element;

[0015] FIGURE 5 is a schematic bottom plan view of an illustrative embodiment of a porous member and a tissue-fixation element;

[0016] FIGURE 6 is a schematic bottom plan view of an illustrative embodiment of a porous member and a tissue-fixation element;

[0017] FIGURE 7 is a schematic bottom plan view of an illustrative embodiment of a porous member and a tissue-fixation element;

[0018] FIGURE 8 is a schematic cross section of a portion of an illustrative embodiment of a reduced-pressure system for treating a tissue site;

[0019] FIGURE 9 is a schematic top view of a distribution manifold on a patient;

[0020] FIGURE 10 is a schematic cross section of a portion of an illustrative embodiment of a reduced-pressure system for treating a tissue site;

[0021] FIGURE 11 is a schematic, perspective view of an illustrative embodiment of a porous member having notches; and

[0022] FIGURE 12 is a schematic, perspective view of an illustrative embodiment of a porous member having notches.



## DETAILED DESCRIPTION OF ILLUSTRATIVE EMBODIMENTS

[0023] In the following detailed description of the illustrative, non-limiting embodiments, reference is made to the accompanying drawings that form a part hereof. These embodiments are described in sufficient detail to enable those skilled in the art to practice the invention, and it is understood that other embodiments may be utilized and that logical structural, mechanical, electrical, and chemical changes may be made without departing from the spirit or scope of the invention. To avoid detail not necessary to enable those skilled in the art to practice the embodiments described herein, the description may omit certain information known to those skilled in the art. The following detailed description is not to be taken in a limiting sense, and the scope of the illustrative embodiments are defined only by the appended claims.

[0024] Referring now primarily to FIGURES 1 and 2, a reduced-pressure system 100 for treating a tissue site 102 of a patient 104 with reduced pressure is presented. The reduced pressure treatment may be used to promote tissue growth, help approximate a wound, remove fluids, or other purposes. Unless otherwise indicated, as used throughout this document, “or” does not require mutual exclusivity. The tissue site 102 may be, as a non-limiting example, an incision 106. The incision 106 is shown with a stitch 108 helping to hold the incision 106 in a closed position. The incision 106 may be through the patient’s 104 epidermis 110, dermis 112, and into the subcutaneous tissue 114. The tissue site 102 may be the bodily tissue of any human, animal, or other organism, including bone tissue, adipose tissue, muscle tissue, dermal tissue, vascular tissue, connective tissue, cartilage, tendons, ligaments, or any other tissue.

[0025] The reduced-pressure system 100 includes a distribution manifold 116 that is disposed adjacent to the tissue site 102. The distribution manifold 116 includes a porous member 118 having a plurality of flow channels for distributing reduced pressure and receiving fluids. The porous member 118 has a first side 120 and a second, tissue-facing side 122. As shown best in FIGURE 2, the distribution manifold 116 may also include a fluid-permeable substrate member 124 having a first side 125 and a second, tissue-facing side 127. The second, tissue-facing side 122 of the porous member 118 is proximate to the first side 125 of the fluid-permeable substrate member 124. The second, tissue-facing side 127 of the fluid-permeable substrate member 124 has a surface area  $A_s$ .

[0026] The porous member of the distribution manifold 116 refers to a substance or structure that is provided to assist in applying reduced pressure to, delivering fluids to, or removing fluids from a tissue site. The porous member 118 typically includes a plurality of flow channels or pathways that distribute fluids provided to and removed from the tissue site 102 around the distribution manifold 116. In one illustrative embodiment, the flow channels or pathways are interconnected to improve distribution of fluids provided or removed from the tissue site 102. The porous member 118 may be a biocompatible material that may be placed directly in contact with the tissue site 102 and distributes reduced pressure. Examples of porous members 118 may include, without limitation, devices that have structural elements arranged to form flow channels, such as, for example, cellular foam, open-cell foam, porous tissue collections, liquids, gels, and foams that include, or cure to include, flow channels. The porous member 118 may be made from foam, gauze, felted mat, or any other material suited to a particular biological application. In one embodiment, the porous member 118 is a porous foam and includes a plurality of interconnected cells or pores that act as flow channels. The porous foam may be a polyurethane, open-cell, reticulated foam such as GranuFoam® material manufactured by Kinetic Concepts, Incorporated of San Antonio, Texas. In some situations, the porous member 118 may also be used to distribute fluids such as medications, antibacterials, growth factors, and various solutions to the tissue site 102. Other layers may be included in or on the porous member 118, such as absorptive materials, wicking materials, hydrophobic materials, and hydrophilic materials.

[0027] In one illustrative embodiment, the porous member 118 may be constructed from a bioresorbable material that if used with an open wound does not have to be removed from a patient's body following use. Suitable bioresorbable materials may include, without limitation, a polymeric blend of polylactic acid (PLA) and polyglycolic acid (PGA). The polymeric blend may also include without limitation polycarbonates, polyfumarates, and capralactones. The porous member 118 may further serve as a scaffold for new cell-growth, or a scaffold material may be used in conjunction with the porous member 118 to promote cell-growth. A scaffold is a substance or structure used to enhance or promote the growth of cells or formation of tissue, such as a three-dimensional porous structure that provides a template for cell growth. Illustrative examples of scaffold materials include calcium phosphate, collagen, PLA/PGA, coral hydroxy apatites, carbonates, or processed allograft

materials. The porous member 118 may take any shape, e.g., a rectangle, a square, triangle, a circle, or any other shape.

5 [0028] As shown in FIGURE 2, the lateral edges 123 of the porous member 118 may be shaped edges to smoothly offload forces on the porous member 118 to the tissue site 102 or areas near the tissue site 102. For example, the lateral edges 123 of the porous member 118 may be formed, as a non-limiting example, at a 45 degree angle as shown or a 30 degree angle or another angle that helps off load forces. As explained later in connection with FIGURES 10 and 11, the porous member 118 may have notches formed on the first side 120 to enhance flexibility of the porous member 118.

10 [0029] The distribution manifold 116 may include the fluid-permeable substrate member 124. The fluid-permeable substrate member 124 is operational to prevent or inhibit irritation of the tissue site 102 by the porous member 118. The fluid-permeable substrate member 124 may be a woven material, non-woven material (using such fiber forming polymers as polyvinyl alcohols, polyvinyl acetates, polyethylenes, polyesters, polyamides, 15 polyacrylics and polyacrylates, cellulosics and their copolymers, and where non ionizing radiation methods of sterilization are used, polypropylene), fenestrated drape or film (using such fiber-forming polymers as just listed), a high density foam (higher density than the porous member 118) or any material that inhibits irritation of the tissue site 102 by the porous member 118 while allowing fluid transmission. The fluid-permeable substrate member 124 may make attachment of a tissue-fixation element 126 (described further below) easier. The fluid-permeable substrate member 124 may be coupled to the distribution manifold 116 using an adhesive bond, flame lamination or heat lamination, spray adhesive, hot melt, or any other device or technique. The fluid-permeable substrate member 124 may be coupled to the distribution manifold 116 by forming an integral foam or film such as by using compressed or 25 felting foams and co-blown foam and film.

[0030] The fluid-permeable substrate member 124 may contain medicaments, e.g., antimicrobials, lidocaine, or other substances, to treat the tissue site 102. The fluid-permeable substrate member 124 may be a solid substrate or may only partially cover the porous member 118. Coupled includes coupling via a separate object and includes direct coupling. The term 30 coupled also encompasses two or more components that are continuous with one another by virtue of each of the components being formed from the same piece of material. Coupling

may also include chemical, such as via a chemical bond, mechanical, thermal, or electrical coupling. Fluid coupling means that fluid may be in communication between the designated parts or locations.

5 [0031] The distribution manifold 116 includes the tissue-fixation element 126. As will be explained below, the tissue-fixation element 126 is operational to tack or at least temporarily attach the distribution manifold 116 to the tissue site 102 while other aspects of the reduced-pressure system 100 are applied. The tissue-fixation element 126 has a first side 128 and a second, tissue-facing side 130. The first side 128 of the tissue-fixation element 126 may be coupled to the second, tissue-facing side 127 of the fluid-permeable substrate member 124 or in some embodiments directly to the second, tissue-facing side 122 of the porous member 118. The second, tissue-facing side 130 of the tissue-fixation element 126 has a surface area  $A_t$ . The tackiness of tissue-fixation element 126 may be such that the tissue-fixation element 126 will separate from the tissue site 102 before the fluid-permeable substrate member 124 separates from the porous member 118. In other words, the strength of tackiness of the tissue-fixation element 126 to the tissue site 102 is less than the strength of the bond between the tissue-fixation element 126 and the fluid-permeable substrate member 124.

10 [0032] The relationship of the surface area  $A_t$  of the tissue-fixation element 126 to the surface area  $A_s$  of the fluid-permeable substrate member 124 may be  $0.05A_s < A_t < 0.6A_s$ . Other relationships between the surface areas  $A_t$ ,  $A_s$  are contemplated. As non-limiting, 20 illustrative examples, the following relationships may be realized:  $0.10A_s < A_t < 0.8A_s$ ,  $0.10A_s < A_t < 0.5A_s$ ,  $0.15A_s < A_t < 0.4A_s$ ,  $0.20A_s < A_t < 0.4A_s$ , or other relationships. The relationship of the surface areas is such that for a given tackiness of a tissue-fixation element 126, the surface area  $A_t$  provides adequate force to hold the distribution manifold 116 adjacent to the tissue site 102 notwithstanding gravitational forces from the gravitational field 131. In 25 the illustrative embodiments that do not utilize the fluid-permeable substrate member 124, the relationships are analogous as between the surface area  $A_p$  of the second, tissue-facing side 122 of the porous member 118 and the area  $A_t$  of the tissue-fixation element 126, e.g.,  $0.05A_p < A_t < 0.7A_p$ .

30 [0033] The tissue-fixation element 126 may take numerous shapes or form numerous patterns. For example, the tissue-fixation element 126 may comprise spaced strips or lines coupled to the second, tissue-facing side 127 of the fluid-permeable substrate member 124 (or

alternatively the second, tissue-facing side 122 of the porous member 118) as shown in FIGURES 3 and 4. Other examples of patterns the tissue-fixation element 126 may take include, without limitation, islands or circles (uniform or random) as shown in FIGURE 5, concentric circles as shown in FIGURE 6, mesh as shown in FIGURE 7, concentric squares, triangles, diamonds, or any other pattern. Typically, the pattern involves less than 100 percent coverage of the second, tissue-facing side 127 of the fluid-permeable substrate member 124 (or alternatively the second, tissue-facing side 122 of the porous member 118), but if a tissue-fixation element 126 is used that allows fluid migration through the tissue-fixation element 126, 100 percent (100%) coverage may be used. As non-limiting examples, in FIGURE 3,  $A_t$  is approximately 25% (0.25) of  $A_s$ , and in FIGURE 4,  $A_t$  is approximately 50% (0.5) of  $A_s$ .

**[0034]** The tissue-fixation element 126 may be a water-soluble adhesive or a non-water-soluble adhesive. In one illustrative embodiment, the tissue-fixation element 126 is a water-soluble adhesive that dissolves at least after one hour of contact with liquid and yet remains at least 10 minutes in contact with a liquid. In another illustrative embodiment, the tissue-fixation element 126 is an adhesive activated by contact with an aqueous liquid. In another illustrative embodiment, the tissue-fixation element 126 is a water-soluble adhesive that remains for at least ten minutes when in contact with a liquid and substantially dissolves at least within one hour or within three hours of contact with a liquid. In some embodiments using a water-soluble adhesive, if a user desires to increase the rate of dissolution of the tissue-fixation element 126, a saline solution may be injected into the porous member 118.

**[0035]** With the non-water soluble version of the tissue-fixation element 126, the extent of the tissue-fixation element 126 on the porous member 118 or fluid-permeable substrate member 124 is adequate to allow flow of reduced pressure through the distribution manifold 116 for treatment from the start and at the same time adequate to tack or keep the distribution manifold 116 in place even when directly opposed by the gravitation field 131. In some embodiments, the tackiness of the tissue-fixation element 126 may be varied in strength at different locations on the porous member 118 or fluid-permeable substrate member 124.

**[0036]** In embodiments using a non-soluble tissue-fixation element 126, a non-soluble adhesive may be used. Non-limiting examples of non-soluble adhesives include colloids, hydrogels, silicone, lastomers, acrylics, polyurethanes, and polyvinyl acetates. In embodiments using a water-soluble tissue-fixation element 126, a water-soluble dispersible

adhesive may be used to form the tissue-fixation element 126. Non-limiting examples of soluble or water sensitive dispersible adhesives that might be used include the following: Polyvinyl alcohol (PVOH), polyvinyl pyrrolidone (PVP), polyethylene oxide (PEO), polypropylene oxide (PPO), modified cellulose (such as carboxymethyl cellulose [CMC]) and cellulose ethers, hydroxyl and carboxy modified polymers, such as poly acrylics, poly acrylates, poly amides, polyesters, and polyurethanes and their salts (for example sodium, potassium, and ammonium), polyacrylamides, gums such as guar and xanthan, polyethylene glycols. Also, water solubility may be triggered through a change in pH or by substitution. For example, formation of a sodium salt from a carboxyl group to form a sodium carboxylate may be the trigger. These changes may be brought about using external sources, such as adding a high pH solution to the dressing (wound) where a carboxy functionality (acidic) is neutralized and made water soluble, or the additive is within the polymer matrix, becoming active and mobile on the absorption of moisture (from the wound or and external source, e.g. instillation). One commercially available water soluble substance that may be sufficient is a “Water Soluble Tape,” which is used in wave soldering of circuit boards, and is available from 3M of St. Paul, Minnesota. The tissue-fixation element 126 may be formed with various medicaments, e.g., silver, included to provide additional therapy benefits. The tissue-fixation element 126 may also be formed from gels or colloids that provide additional conditioning of the tissue site 102 or that might help reduce irritation near the tissue site 102 being treated.

**[0037]** As shown in FIGURE 2, a release liner 129 may be used to cover the second, tissue-facing side 130 of the tissue-fixation element 126. The release liner 129 covers the second, tissue-facing side 130 of the tissue-fixation element 126 for storage or before the tissue-fixation element 126 is applied. The release liner 129 has a first side 135 and a second, tissue-facing side 137. In a stored state, the first side 135 of the release liner 129 is removably coupled to the second, tissue-facing side 130 of the tissue-fixation element 126.

**[0038]** Referring again primarily to FIGURE 1, the reduced-pressure system 100 further includes a sealing member 132 for disposing over the distribution manifold 116 and a portion of intact epidermis 110 to create a sealed space 133 containing the distribution manifold 116. The sealing member 132 may be any material that provides a fluid seal. A fluid seal is a seal adequate to maintain reduced pressure at a desired site given the particular reduced-pressure source or subsystem involved. The sealing member 132 may, for example,

be an impermeable or semi-permeable, elastomeric material. Elastomeric materials have the properties of an elastomer. Elastomeric generally refers to a polymeric material that has rubber-like properties. More specifically, most elastomers have ultimate elongations greater than 100% and a significant amount of resilience. The resilience of a material refers to the material's ability to recover from an elastic deformation. Examples of elastomers may include, but are not limited to, natural rubbers, polyisoprene, styrene butadiene rubber, chloroprene rubber, polybutadiene, nitrile rubber, butyl rubber, ethylene propylene rubber, ethylene propylene diene monomer, chlorosulfonated polyethylene, polysulfide rubber, polyurethane (PU), EVA film, co-polyester, and silicones. Additional, specific examples of sealing member materials include a silicone drape, a 3M Tegaderm® drape, or a polyurethane (PU) drape such as one available from Avery Dennison Corporation of Pasadena, California.

**[0039]** The sealing member 132 may have an attachment device 134 on a tissue-facing side 136. The attachment device 134 may be used to hold the sealing member 132 against the patient's epidermis 110 or another layer, such as a gasket or additional sealing member. The attachment device 134 may take numerous forms. For example, the attachment device 134 may be a medically acceptable, pressure-sensitive adhesive that extends about a periphery or all of the sealing member 132. As additional examples, the attachment device 134 may be a double-sided drape tape, paste, hydrocolloid, hydro gel or other sealing devices or elements.

**[0040]** The reduced-pressure system 100 further includes a reduced-pressure source 138 that may be fluidly coupled to the sealed space 133 and to the distribution manifold 116. The reduced-pressure source 138 may be coupled by a reduced-pressure delivery conduit 140 to a reduced-pressure interface 142. The reduced-pressure source 138 may be an external source as shown in FIGURE 1 and may be fluidly coupled with the reduced-pressure delivery conduit 140. Alternatively, the reduced-pressure source 138 may be incorporated into the porous member 118 or disposed adjacent to the distribution manifold 116. The reduced-pressure source 138 may be any device for supplying a reduced pressure, such as a vacuum pump, wall suction, micro-pump, or other source. While the amount and nature of reduced pressure applied to a tissue site will typically vary according to the application, the reduced pressure will typically be between -5 mm Hg (-667 Pa) and -500 mm Hg (-66.7 kPa) and more

typically between -75 mm Hg (-9.9 kPa) and -300 mm Hg (-39.9 kPa), and more typically still between -100 mm Hg (-13.3 kPa) and -150 mm Hg (-19.9 kPa).

[0041] In some embodiments of the reduced-pressure system 100, the reduced-pressure interface 142 provides fluid communication to the sealed space 133. In one illustrative embodiment, the reduced-pressure interface 142 is a T.R.A.C.<sup>®</sup> Pad or Sensa T.R.A.C.<sup>®</sup> Pad available from KCI of San Antonio, Texas.

[0042] Reduced pressure generally refers to a pressure less than the ambient pressure at a tissue site that is being subjected to treatment. In most cases, this reduced pressure will be less than the atmospheric pressure at which the patient is located. Alternatively, the reduced pressure may be less than a hydrostatic pressure at the tissue site. Reduced pressure may initially generate fluid flow in the distribution manifold 116, reduced-pressure delivery conduit 140, and proximate the tissue site 102. As the hydrostatic pressure around the tissue site 102 approaches the desired reduced pressure, the flow may subside, and the reduced pressure may be maintained. Unless otherwise indicated, values of pressure stated herein are gauge pressures. The reduced pressure delivered may be constant or varied (patterned or random) and may be delivered continuously or intermittently. Consistent with the use herein, an increase in reduced pressure or vacuum pressure typically refers to a relative reduction in absolute pressure.

[0043] A liquid receptor 144 may be fluidly coupled to (or included as an aspect of) the distribution manifold 116 for receiving fluids from the patient 104 under the influence of reduced pressure provided by the reduced-pressure source 138. The liquid receptor 144 may be a canister 146 as shown in FIGURE 1 or may be an absorbent layer associated with the distribution manifold 116.

[0044] Referring primarily to FIGURES 1 and 2, in operation according to one illustrative embodiment, the distribution manifold 116 is sized for the tissue site 102 by selecting an appropriately sized distribution manifold 116 or cutting the distribution manifold 116 to size. If applicable, the distribution manifold 116 is prepared for application by removing the release liner 129. The second, tissue-facing side 130 of the tissue-fixation element 126 is disposed adjacent to the tissue site 102. The tissue-fixation element 126 adheres, at least temporarily, to the tissue site 102. The distribution manifold 116 thus remains substantially adjacent to the tissue site 102. In this way, the patient 104 may have the



tissue site 102 parallel to the gravitational field 131 and nonetheless the distribution manifold 116 will remain at the desired location on the tissue site 102. The distribution manifold 116 may remain against the tissue site 102 even when all exterior support has been removed such that the distribution manifold 116 is suspended by only the tissue-fixation element 126 and perhaps to some extent by the tissue site 102 itself. In other words, the distribution manifold 116 may be retained adjacent to the tissue site 102 without any additional tools or supports other than the tissue-fixation element 126.

[0045] The sealing member 132 may then be disposed over the distribution manifold 116 and a portion of the intact epidermis 110 to create the sealed space 133. The distribution manifold 116 is disposed in the sealed space 133. If not already applied, the reduced-pressure interface 142 may be applied to the sealing member 132. The reduced-pressure delivery conduit 140 may be fluidly coupled between the reduced-pressure source 138 and the reduced-pressure interface 142. The reduced-pressure source 138 is activated and reduced pressure is thereby supplied to the sealed space 133 and fluids may flow from the tissue site 102 to the liquid receptor 144. The pattern of the tissue-fixation element 126 may allow a contracting force to be experienced in 360 degrees at the tissue site 102 during treatment. The contracting force is developed by contraction of the distribution manifold 116 or the sealing member 132 under the influence of reduced pressure.

[0046] In embodiments using a water-soluble tissue-fixation element 126, the tissue-fixation element 126 initially retains the distribution manifold 116 adjacent to the tissue site 102 and then with time the tissue-fixation element 126 dissolves. In one illustrative embodiment, the tissue-fixation element 126 remains at least ten (10) minutes in contact with a liquid and dissolves at least within one (1) hour, two (2) hours, or three (3) hours of contact with liquid. Because of the partial coverage of second, tissue-facing side 122 of the porous member 118 or fluid-permeable substrate member 124 by the tissue-fixation element 126, reduced pressure may immediately flow through the distribution manifold 116 to the tissue site 102 and may do so with more available flow paths as the tissue-fixation element 126 dissolves. In other embodiments, using a non-water-soluble tissue-fixation element 126, the pattern of the tissue-fixation element 126 remains and allows adequate flow between portions of the tissue-fixation element 126 or the tissue-fixation element 126 itself may allow fluid

flow through the tissue-fixation element 126, i.e., the tissue-fixation element 126 may be fluid permeable.

[0047] Referring now primarily to FIGURE 8, a portion of another illustrative embodiment of a reduced-pressure system 100 is presented. The reduced-pressure system 100 of FIGURE 8 is analogous to the reduced-pressure system 100 of FIGURE 1 with two main differences: a plurality of malleable members 152 have been added to the porous member 118 and the fluid-permeable substrate member 124 extends beyond the lateral edge 123 of the porous member 118.

[0048] The plurality of malleable members 152 plastically deform the distribution manifold 116 in order to accommodate a curved surface of the patient 104, such as a leg, arm, breast, or a complex surface. The plurality of malleable members 152 may be formed from steel or any plastically deformable members. While in cross section only one of the plurality of malleable members 152 is shown, it should be understood that any number of spaced members may be included. In operation, the distribution manifold 116 is plastically deformed to the shape of the curved surface of the patient 104 to be treated. The plurality of malleable member 152 retain the shape. The reduced-pressure system 100 may then be applied analogously to the deployment previously presented.

[0049] Referring now primarily to FIGURE 9, a top view of a portion of another illustrative embodiment of a reduced-pressure system 100 is presented. The porous member 118 is shown with broken lines on an incision 106, which is also shown with broken lines. In this embodiment, the tissue-fixation element 126 extends beyond the porous member 118 to form an extension portion 154. The extension portion 154 helps off load forces to the epidermis 110 of the patient 104. In other embodiments, the fluid-permeable substrate member 124 may extend beyond the porous member 118 to offload forces.

[0050] Referring now primarily to FIGURE 10, another illustrative embodiment of a distribution manifold 116 is presented. In FIGURE 10, the sealing member 132 has not yet been applied. The distribution manifold 116 of FIGURE 10 is analogous to the previous embodiments except that a plurality of notches 156 or cuts have been formed on the first side 120 of the porous member 118. The plurality of notches 156 help the distribution manifold 116 to flex or curve with a body part of the patient 104 or with movement of the patient's body. The plurality of notches 156 may be lateral cuts as suggested in FIGURE 10, a grid or

mesh pattern of cuts as shown in FIGURE 11, hexagonal shaped cuts as shown in FIGURE 12, or another shape.

[0051] In another illustrative embodiment, the tissue-fixation element 126 may be a liquid-activated adhesive. In such an embodiment, the tissue-fixation element 126 may be activated by liquids at the tissue site from the wound, saline, or skin preparation liquids. The user disposes the liquid-activated adhesive of the tissue-fixation element 126 against the tissue site 102 and allows the liquids present to activate the tackiness of the tissue-fixation element 126.

[0052] In another illustrative device, the tissue-fixation element 126 may be included as an aspect of the fluid-permeable substrate member 124. For example, in one illustrative embodiment, the fluid-permeable substrate member 124 may be a woven material with super absorbent fibers woven into the material. The super absorbent fibers become tacky when moistened. Other fibers or materials may be included in the fluid-permeable substrate member 124 to provide tackiness when moist, such as other water sensitive or crosslinked water soluble polymers (e.g., polyvinyl alcohol, carboxymethyl cellulose, alginates, and other natural gums such as xanthan and guar).

[0053] In another illustrative embodiment, a tissue-fixation element 126 may be stored separately with release liners, e.g., release liner 129, on both the first side 128 and the second, tissue-facing side 130. In use, the release liner is removed from the first side 128 and applied to the second, tissue-facing side 122 of the porous member 118 or the second, tissue-facing side 127 of the fluid-permeable substrate member 124. Then the release liner is removed from the second, tissue-facing side 130 of the tissue-fixation element 126, and the tissue-fixation element 126 is brought into contact with the tissue site 102. Alternatively, the release liner may first be removed from the second, tissue-facing side 130 of the tissue-fixation element 126 and applied to the tissue site 102. Then the release liner may be removed from the first side 128 of the tissue-fixation element 126 and the porous member 118 or fluid-permeable substrate member 124 applied adjacent to the tissue-fixation element 126. In another illustrative embodiment, the tackiness and strength of the tissue-fixation element 126 may be such that the tissue-fixation element 126 supplements the sutures or functions as sutures in holding an incision 106 in a closed position.

[0054] In another illustrative device, the sealing member 132 may be applied to the first side 120 of the porous member 118 and the tissue-fixation element 126 may be coupled to the second, tissue-facing side 127 of the fluid-permeable substrate member or the second, tissue facing side 122 of the porous member 118. The release liner 129 may cover the second, tissue-facing side 130 of the tissue-fixation element 126 and the second, tissue-facing side 139 of the sealing member 132. In this way, removing the release liner 129 in order to apply the sealing member 132 assures that the release liner 148 has also been removed from the tissue-fixation element 126.

[0055] With the illustrative embodiments herein, a distribution manifold 116 may be applied by a single user without requiring additional tools to hold the porous member 118 in place while the sealing member 132 is applied. Moreover, the user may have two hands available to apply the sealing member 132. The tackiness of the tissue-fixation element 126 may be such that the user may reposition the porous member 118 relative to the tissue site 102 before the sealing member 132 is applied.

[0056] In addition, the distribution manifold 116 may be applied with the patient in a prevailing position, which is a position that the patient will remain for a majority of time during treatment. This means a patient with a tissue site 102 that is on a vertical surface (parallel to the gravitational field 131) may have the distribution manifold 116 applied while remaining in the vertical position. In contrast, if a distribution manifold 116 on such a patient 104 is applied to the tissue site 102 in the horizontal position (orthogonal to gravitational field 131), when the patient again assumes a vertical position, they may find the distribution manifold 116 pulling and fitting in ways that are not comfortable to the patient.

[0057] Although the present invention and its advantages have been disclosed in the context of certain illustrative embodiments, it should be understood that various changes, substitutions, permutations, and alterations can be made without departing from the scope of the invention as defined by the appended claims. It will be appreciated that any feature that is described in connection to any one embodiment may also be applicable to any other embodiment. For example, the malleable members 152 of FIGURE 8 may be included in the embodiment of FIGURE 1.

**CLAIMS**

Claim 1. A reduced-pressure system for treating a tissue site, the system comprising:  
a distribution manifold comprising:

5 a porous member having a plurality of flow channels for distributing reduced pressure and receiving fluids, the porous member having a first side and a second, tissue-facing side,

10 a fluid-permeable substrate member having a first side and a second, tissue-facing side, wherein the second, tissue-facing side of the porous member is proximate to the first side of the fluid-permeable substrate member, and wherein the second, tissue-facing side of the fluid-permeable substrate member has a surface area  $A_s$ , and

15 a tissue-fixation element having a first side and a second, tissue-facing side, and wherein the first side of the tissue-fixation element is coupled to the second, tissue-facing side of the fluid-permeable substrate member, wherein the second, tissue-facing side of the tissue-fixation element has a surface area  $A_t$ , and wherein  $0.05A_s < A_t < 0.7A_s$ ;

a sealing member for disposing over the distribution manifold to create a sealed space containing the distribution manifold;

20 a reduced-pressure source fluidly coupled to the sealed space for providing reduced pressure to the sealed space; and

a liquid receptor fluidly coupled to distribution manifold for receiving fluids from the patient under the influence of reduced pressure from the reduced-pressure source.

25 Claim 2. The system of claim 1, wherein the distribution manifold further comprises a release liner having a first side and a second, tissue-facing side, and wherein, in a stored state, the first side of the release liner is removably coupled to the second, tissue-facing side of the tissue-fixation element.

Claim 3. The system of claim 1, wherein  $0.10A_s < A_t < 0.5A_s$ .

Claim 4. The system of claim 1, wherein  $0.20A_s < A_t < 0.4A_s$ .

- Claim 5. The system of claim 1 or any of claims 2-4, wherein tissue-fixation element comprises a water-soluble adhesive that dissolves at least after one hour of contact with liquid.
- 5 Claim 6. The system of claim 1 or any of claims 2-4, wherein tissue-fixation element comprises a water-soluble adhesive that remains for at least ten minutes when in contact with a liquid.
- Claim 7. The system of claim 1 or any of claims 2-6, wherein tissue-fixation element comprises an adhesive activated by contact with an aqueous liquid.
- 10 Claim 8. The system of claim 1 or any of claims 2-4, wherein tissue-fixation element comprises a water-soluble adhesive that remains for at least ten minutes when in contact with a liquid and substantially dissolves at least within three hours of contact with a liquid.
- Claim 9. The system of claim 1 or any of claims 2-4, wherein tissue-fixation element comprises a non-water-soluble adhesive.
- 15 Claim 10. The system of claim 1 or any of the preceding claims, wherein the distribution manifold further comprises a plurality of malleable members for plastically deforming with the distribution manifold to accommodate a curved surface.
- 20 Claim 11. The system of claim 1 or any of the preceding claims, wherein the tissue-fixation element comprises a patterned distribution of an adhesive and the pattern comprises one of the following: a plurality of concentric circles, a plurality of squares, a plurality of triangles, a plurality of circles, a plurality of spaced lines, and a plurality of diamonds.
- Claim 12. The system of claim 1 or any of the preceding claims, wherein the fluid-permeable substrate comprises a woven layer.
- 25 Claim 13. The system of claim 1 or any of claims 2-11, wherein the fluid-permeable substrate comprises a non-woven layer.
- Claim 14. The system of claim 1 or any of claims 2-11, wherein the fluid-permeable

substrate comprises a fenestrated sealing member.

Claim 15. The system of claim 1 or any of the preceding claims, wherein the porous member further comprises a plurality of notches formed on the first side, wherein the notches provide relatively greater bending flexibility.

5 Claim 16. The system of claim 1 or any of the preceding claims, wherein the porous member further comprises a plurality of shaped edges for off loading forces.

Claim 17. The system of claim 1 or any of the preceding claims, wherein the porous member is shaped to have one of the following shapes: a rectangle, a square, triangle, or a circle.

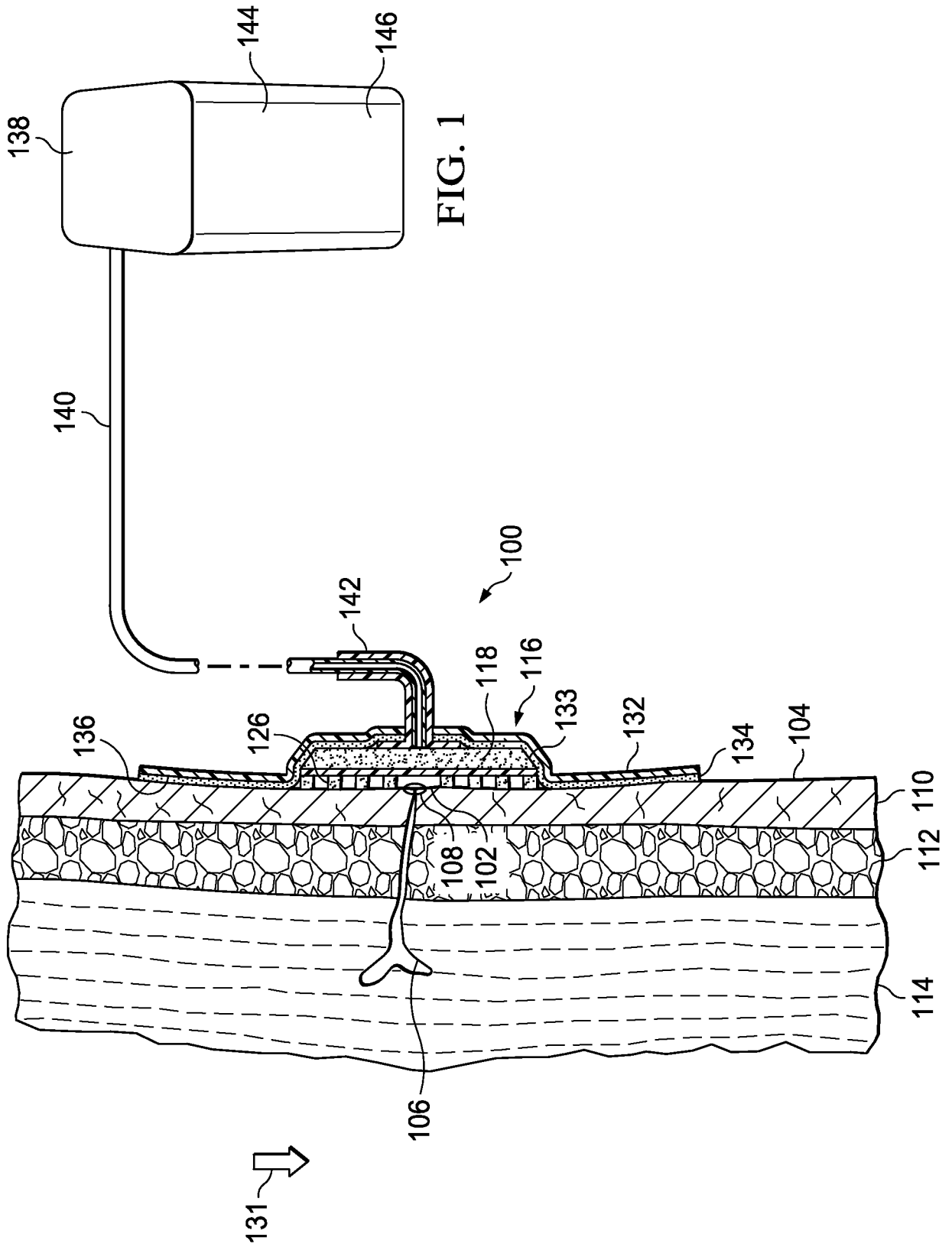



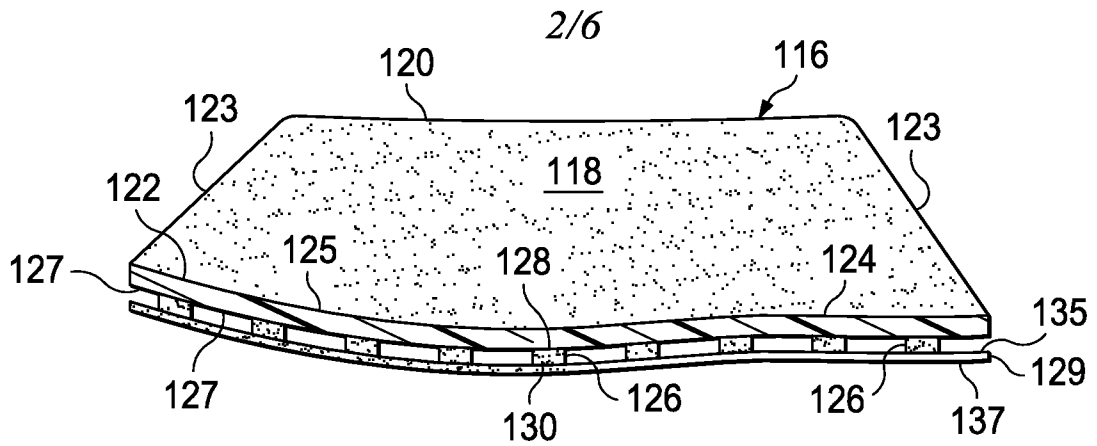

FIG. 2

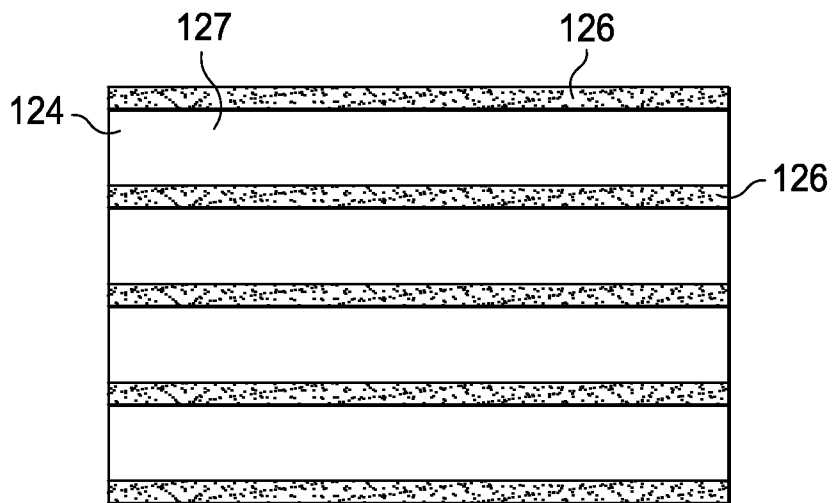

FIG. 3

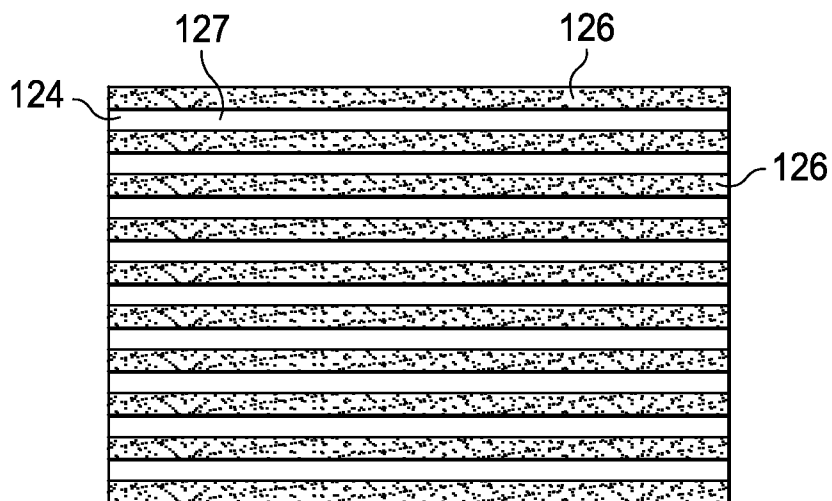

FIG. 4

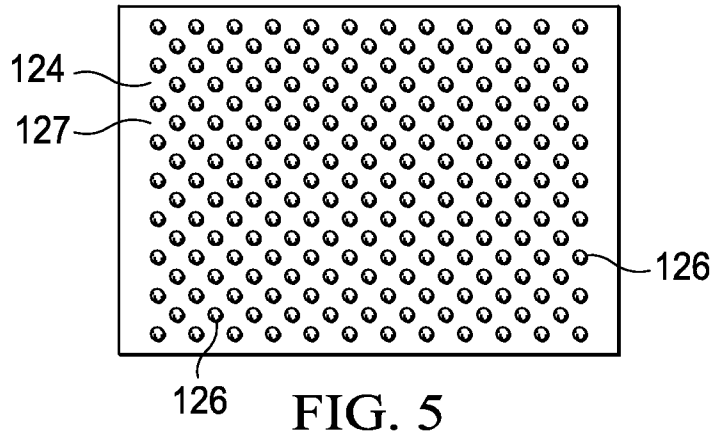

FIG. 5

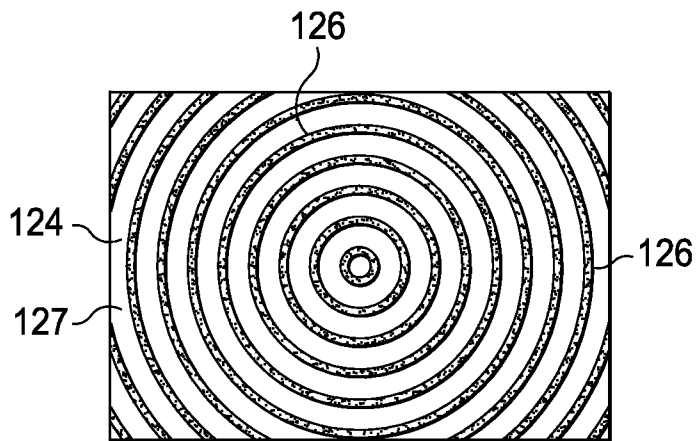

FIG. 6

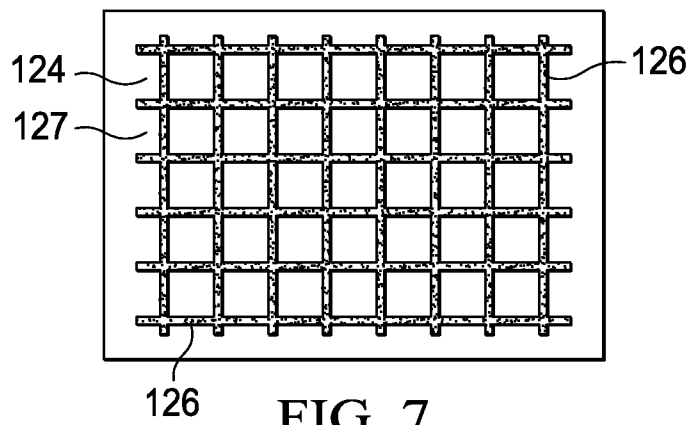

FIG. 7

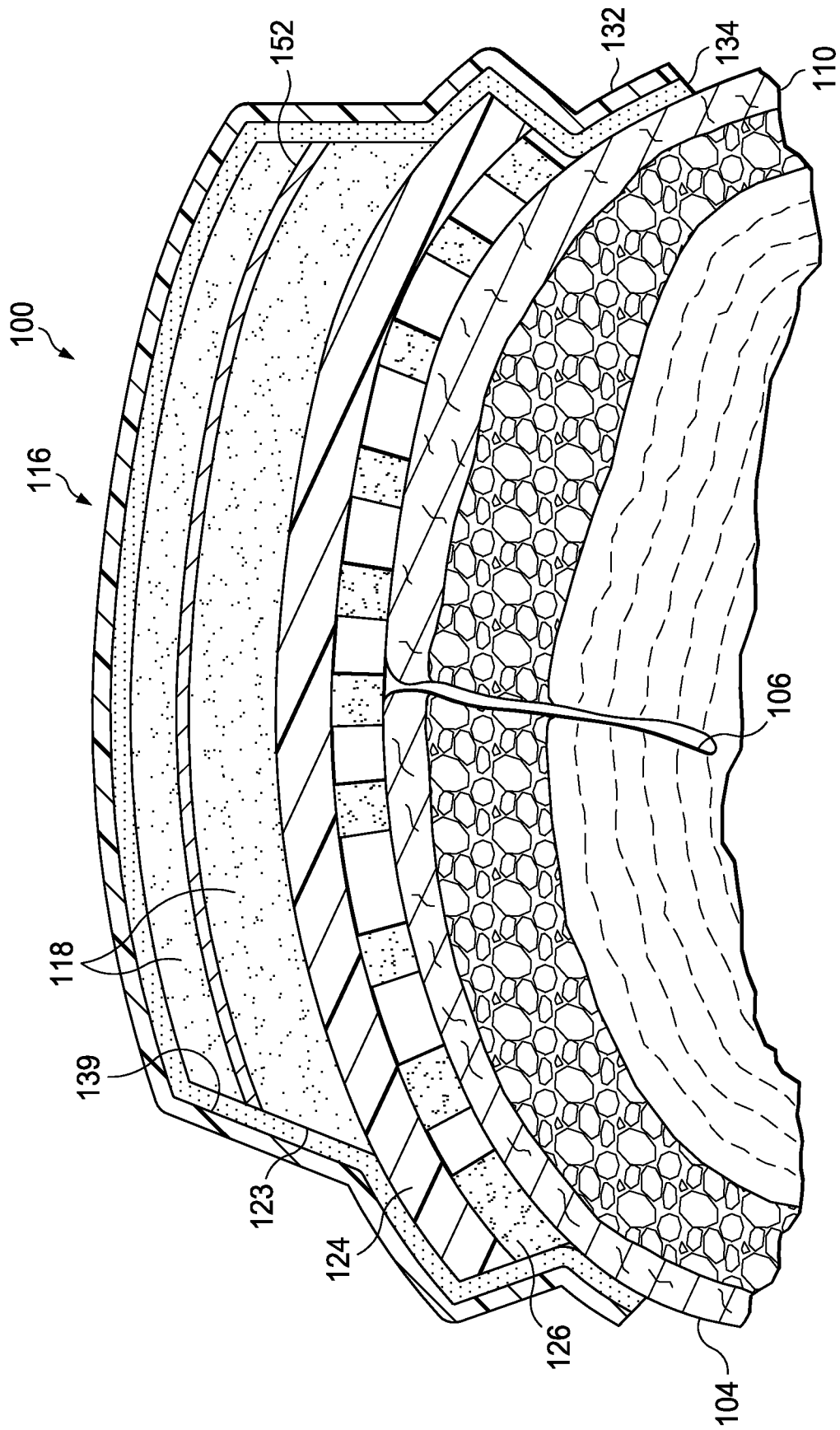

FIG. 8

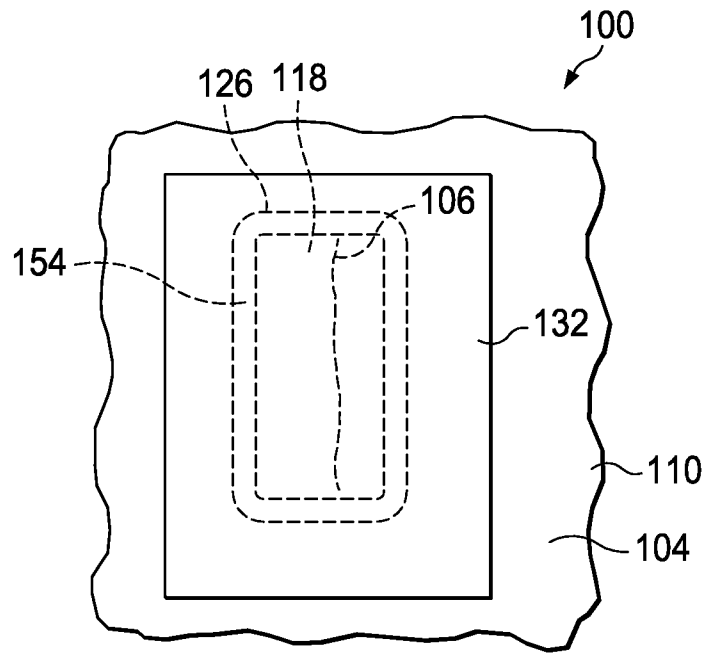

FIG. 9

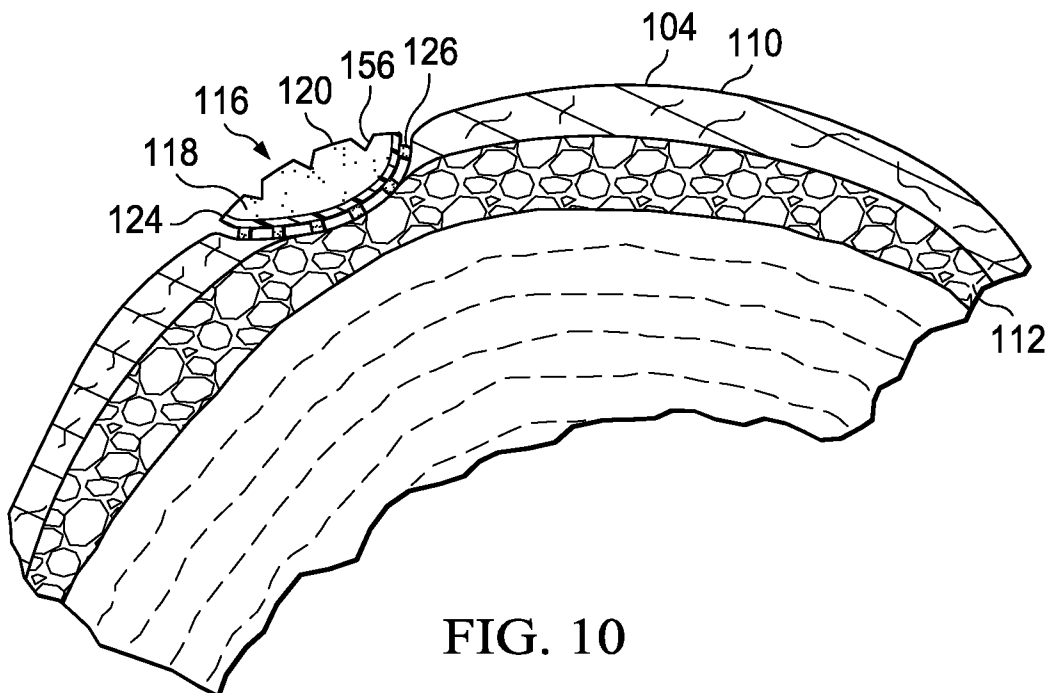

FIG. 10

6/6

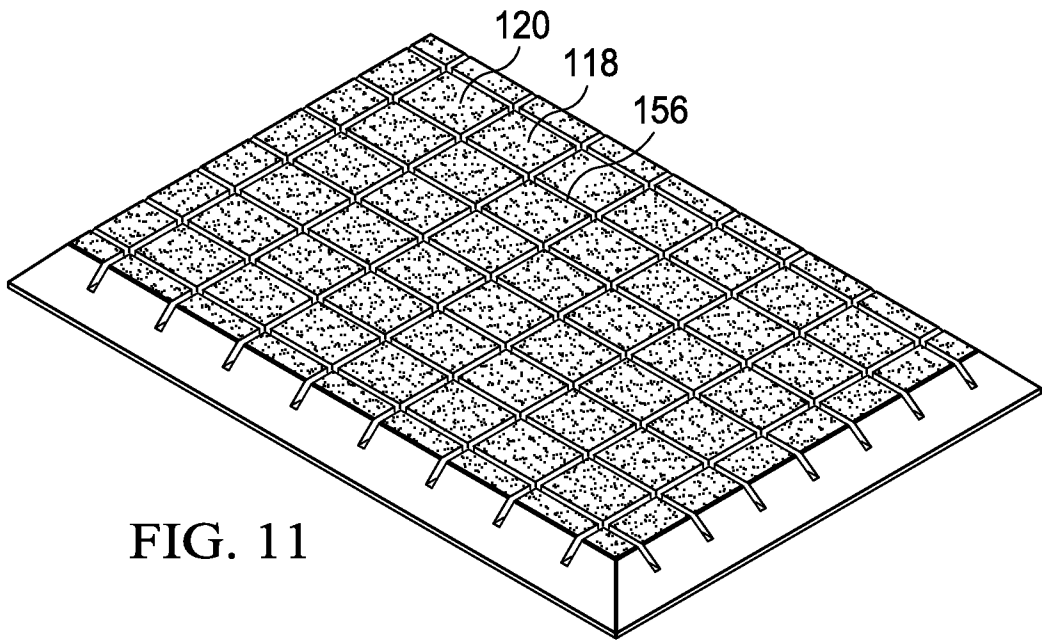

FIG. 11

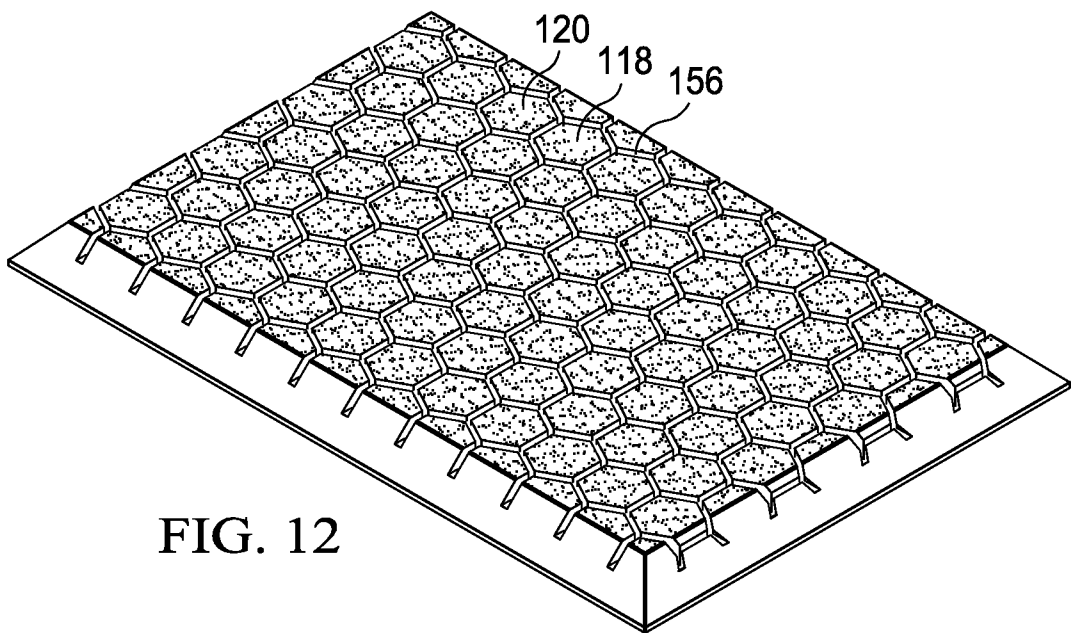

FIG. 12