

(19) World Intellectual Property
Organization
International Bureau



(43) International Publication Date
24 March 2005 (24.03.2005)

PCT

(10) International Publication Number
WO 2005/027031 A2

- (51) International Patent Classification⁷: **G06K 19/00**
- (21) International Application Number:
PCT/US2004/030037
- (22) International Filing Date:
13 September 2004 (13.09.2004)
- (25) Filing Language: English
- (26) Publication Language: English
- (30) Priority Data:
10/661,082 12 September 2003 (12.09.2003) US
10/661,234 12 September 2003 (12.09.2003) US
- (71) Applicants (for all designated States except US):
CYVERA CORPORATION [—/US]; 50 Barnes Park North, Wallingford, CT 06492 (US). **MOON, John, F.** [—/US]; 17 Promontory Drive, Wallingford, CT 06492 (US). **KERSEY, Alan, D.** [—/US]; 75 Taylor Town Road, So. Glastonbury, CT 06073 (US). **PUTNAM, Martin, A.** [—/US]; 78 Lancaster Way, Chesire, CT 06410 (US). **LI, Tuo** [—/US]; 26 Sandpiper Lane, East Lyme, CT 06333 (US).
- (72) Inventors: **DUNPHY, J., R.**; 21 Hickory Drive, South Glastonbury, CT 06073 (US). **DIDDEN, F., Kevin**; 32 Maplevue Road, Wallingford, CT 06492 (US).
- (81) Designated States (unless otherwise indicated, for every kind of national protection available): AE, AG, AL, AM, AT, AU, AZ, BA, BB, BG, BR, BW, BY, BZ, CA, CH, CN, CO, CR, CU, CZ, DE, DK, DM, DZ, EC, EE, EG, ES, FI, GB, GD, GE, GH, GM, HR, HU, ID, IL, IN, IS, JP, KE, KG, KP, KR, KZ, LC, LK, LR, LS, LT, LU, LV, MA, MD, MG, MK, MN, MW, MX, MZ, NA, NI, NO, NZ, OM, PG, PH, PL, PT, RO, RU, SC, SD, SE, SG, SK, SL, SY, TJ, TM, TN, TR, TT, TZ, UA, UG, US, UZ, VC, VN, YU, ZA, ZM, ZW.
- (84) Designated States (unless otherwise indicated, for every kind of regional protection available): ARIPO (BW, GH, GM, KE, LS, MW, MZ, NA, SD, SL, SZ, TZ, UG, ZM, ZW), Eurasian (AM, AZ, BY, KG, KZ, MD, RU, TJ, TM), European (AT, BE, BG, CH, CY, CZ, DE, DK, EE, ES, FI, FR, GB, GR, HU, IE, IT, LU, MC, NL, PL, PT, RO, SE, SI, SK, TR), OAPI (BF, BJ, CF, CG, CI, CM, GA, GN, GQ, GW, ML, MR, NE, SN, TD, TG).
- Published:
— without international search report and to be republished upon receipt of that report

[Continued on next page]

(54) Title: METHOD AND APPARATUS FOR LABELING USING DIFFRACTION GRATING-BASED ENCODED OPTICAL IDENTIFICATION ELEMENTS

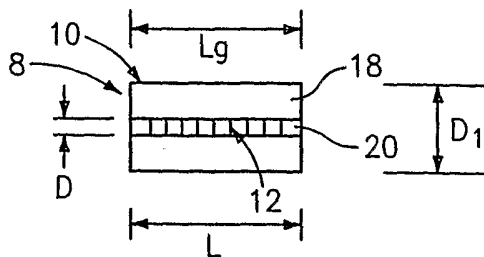

(57) Abstract: A methods and apparatus for labeling an item using diffraction grating-based encoded optical identification elements (8) includes an optical substrate (10) having at least one diffraction grating (12) disposed therein. The grating (12) has one or more collocated pitches A which represent a unique identification digital code that is detected when illuminated by incident light (24). The incident light (24) may be directed transversely from the side of the substrate (10) (or from an end) with a narrow band (single wavelength) or multiple wavelength source, and the code is represented by a spatial distribution of light or a wavelength spectrum, respectively, or a combination thereof. The element (8) can provide a large number of unique codes, e.g., greater than 67 million codes, and can withstand harsh environments. The encoded element (8) may be used to label any desired item, such as large or small objects, products, solids, powders, liquids, gases, plants, minerals, cells and/or animals, or any combination of or portion of one or more thereof. The label may be used for many different purposes, such as for sorting, tracking, identification, verification, authentication, anti-theft/anti-counterfeit, security/anti-terrorism, forensics, or for other purposes. In a manufacturing environment, the elements 8 may be used to track inventory for production information or sales of goods/products.



WO 2005/027031 A2



For two-letter codes and other abbreviations, refer to the "Guidance Notes on Codes and Abbreviations" appearing at the beginning of each regular issue of the PCT Gazette.

**Method and Apparatus for Labeling Using
Diffraction Grating-Based Encoded Optical Identification Elements**

5 Cross References to Related Applications

The following cases contain subject matter related to that disclosed herein and are incorporated herein by reference in their entirety: U.S. Patent Application Serial No. 10/645,689, filed August 20, 2003, entitled "Diffraction Grating-Based Optical Identification Element", (CyVera Docket No. CV-0038); U.S. Patent Application
10 Serial No. 10/645,686 filed August 20, 2003, entitled "Diffraction Grating-Based Encoded Micro-particles for Multiplexed Experiments", (CyVera Docket No. CC-0039); U.S. Patent Application Serial No. 10/661,234, filed September 12, 2003, entitled "Diffraction Grating-Based Optical Identification Element", (CyVera Docket No. CC-0038A); U.S. Patent Application Serial No. 10/661,031, filed September 12,
15 2003, entitled "Diffraction Grating-Based Encoded Micro-particles for Multiplexed Experiments", (CyVera Docket No. CV-0039A); U.S. Patent Application Serial No. 10/661,082, filed September 12, 2003, entitled "Method and Apparatus for Labeling Using Diffraction Grating-Based Encoded Optical Identification Elements", (CyVera Docket No. CV-0040); U.S. Patent Application Serial No. 10/661,115, filed
20 September 12, 2003, entitled "Assay Stick", (CyVera Docket No. CC-0041); U.S. Patent Application Serial No. 10/661,836, filed September 12, 2003, entitled "Method and Apparatus for Aligning Microbeads in order to Interrogate the Same", (CyVera Docket No. CV-0042); U.S. Patent Application Serial No. 10/661,254, filed
25 September 12, 2003, entitled "Chemical Synthesis Using Diffraction Grating-based Encoded Optical Elements", (CyVera Docket No. CV-0043); U.S. Patent Application Serial No. 10/661,116, filed September 12, 2003, entitled "Method of Manufacturing of a Diffraction grating-based identification Element", (CyVera Docket No. CV-0044); and U.S. Patent Application Serial No. 10/763,995 filed January 22, 2004,

entitled, "Hybrid Random Bead/Chip Based Microarray", (CyVera Docket No. CV-0054).

Technical Field

5 This invention relates to optical identification, and more particularly to labeling using diffraction grating-based encoded optical elements.

Background Art

10 It is often desirable to uniquely label or identify items, such as large or small objects, plants, and/or animals for sorting, tracking, identification, verification, authentication, or for other purposes. Existing technologies, such as bar codes, electronic microchips/transponders, radio-frequency identification (RFID), and fluorescence (or other optical techniques), are often inadequate. For example, existing
15 technologies may be too large for certain applications, may not provide enough different codes, cannot be made flexible or bendable, or cannot withstand harsh environments, e.g., harsh temperature, pressure, chemical, nuclear and/or electromagnetic environments.

 Therefore, it would be desirable to obtain a labeling technique that provides the capability of providing many codes (e.g., greater than 1 million codes), that can be
20 made very small, can be made flexible or bendable, and/or that can withstand harsh environments.

Summary of the Invention

25 Objects of the present invention include provision of a labeling technique that allows for a large number of distinct codes, can be made very small, can be made flexible or bendable, and/or can withstand harsh environments.

 According to a first aspect of the present invention, an optical identification element for identifying an item, comprises a substrate having at least one diffraction grating disposed therein, said grating having a resultant refractive variation at a

grating location; said grating providing an output optical signal indicative of a code when illuminated by an incident light signal propagating in free space; and the element being at least partially disposed on the item.

5 According further to the present inventions, said refractive index variation comprises at least one refractive index pitch superimposed at said grating location.

According still further to the present invention, said refractive index variation comprises a plurality of refractive index pitches superimposed at said grating location. According still further to the present invention, said substrate is made of a material selected from the group: glass, silica, plastic, rubber, and polymer.

10 According to a second aspect of the present invention, a method of reading a code associated with an optical identification element that is disposed on an item, the element having a diffraction grating having a resultant refractive index variation at a grating location, comprises illuminating said element with incident light, said grating providing an output light signal indicative of the code; and reading said output light
15 signal and detecting said code therefrom.

According further to the present invention, the item is a drug and/or the element is at least partially embedded in or attached to or mixed with a drug.

The present invention provides a method and apparatus for labeling an item, using diffraction grating-based encoded optical identification elements, capable of
20 having many optically readable codes. The element has a substrate containing an optically readable composite diffraction grating having a one or more of collocated index spacing or pitches Λ . The invention allows for a high number of uniquely identifiable codes (e.g., millions, billions, or more). The codes may be digital binary codes and thus are digitally readable or may be other numerical bases if desired.

25 The encoded element 8 may be used to label any desired item, such as large or small objects, products, solids, powders, liquids, gases, plants, minerals, cells and/or animals, or any combination of or portion of one or more thereof. The label may be used for many different purposes, such as for sorting, tracking, identification, verification, authentication, anti-theft/anti-counterfeit, security/anti-terrorism,

forensics, or for other purposes. In a manufacturing environment, the elements 8 may be used to track inventory for production information or sales of goods/products.

5 The element may be made of a glass material, such as silica or other glasses, or may be made of plastic or polymer, or any other material capable of having a diffraction grating disposed therein. The element may be cylindrical in shape or any other geometry, provided the design parameters are met.

10 Also, the elements may be very small "microbeads" (or microelements or microparticles or encoded particles) for small applications (about 1-1000 microns), or larger "macrobeads" (or macroelements) for larger applications (e.g., 1-1000mm or much larger). Also, the element may be embedded within or part of a larger substrate or object. The element may also be in the form of a thread or fiber to be weaved into a material.

15 The code in the element is interrogated using free-space optics and can be made alignment insensitive. The element may be optically interrogated to read the code from the side or end of the element.

The gratings (or codes) are embedded inside (including on or near the surface) of the substrate and may be permanent non-removable codes that can operate in harsh environments (chemical, temperature, pressure, nuclear, electromagnetic, etc.).

20 The code is not affected by spot imperfections, scratches, cracks or breaks in the substrate. In addition, the codes are spatially invariant. Thus, splitting or slicing an element axially produces more elements with the same code. Accordingly, when a bead is axially split-up, the code is not lost, but instead replicated in each piece.

25 The foregoing and other objects, features and advantages of the present invention will become more apparent in light of the following detailed description of exemplary embodiments thereof.

Brief Description of the Drawings

Fig. 1 is a side view of an optical identification element, in accordance with the present invention.

Fig. 2 is a top level optical schematic for reading a code in an optical identification element, in accordance with the present invention.

Fig. 3, illustrations (a)-(d) show various transparent items that can be labeled with an optical identification element, in accordance with the present invention.

5 Fig. 4, illustrations (a)-(c) show various integrated circuits or silicon wafers, that can be labeled with an optical identification element, in accordance with the present invention.

Fig. 5 shows a cell or the like disposed on an optical identification element, in accordance with the present invention.

10 Fig. 6, illustrations (a)-(d) show fluids or powders that can be labeled with an optical identification element, in accordance with the present invention.

Fig. 7, illustrations (a)-(v) show various other items that can be labeled with an optical identification element, in accordance with the present invention.

15 Fig. 8 shows a bit format for a code in an optical identification element, in accordance with the present invention.

Fig. 9 is an optical schematic for reading a code in an optical identification element, in accordance with the present invention.

Fig. 10 is an image of a code on a CCD camera from an optical identification element, in accordance with the present invention.

20 Fig. 11 is a graph showing a digital representation of bits in a code in an optical identification element, in accordance with the present invention.

Fig. 12 illustrations (a)-(c) show images of digital codes on a CCD camera, in accordance with the present invention.

25 Fig. 13 illustrations (a)-(d) show graphs of different refractive index pitches and a summation graph, in accordance with the present invention.

Fig. 14 is an alternative optical schematic for reading a code in an optical identification element, in accordance with the present invention.

Fig. 15 illustrations (a)-(b) are graphs of reflection and transmission wavelength spectrum for an optical identification element, in accordance with the present invention.

5 Figs. 16-17 are side views of a thin grating for an optical identification element, in accordance with the present invention.

Fig. 18 is a perspective view showing azimuthal multiplexing of a thin grating for an optical identification element, in accordance with the present invention.

Fig. 19 is side view of a blazed grating for an optical identification element, in accordance with the present invention.

10 Fig. 20 is a graph of a plurality of states for each bit in a code for an optical identification element, in accordance with the present invention.

Fig. 21 is a side view of an optical identification element where light is incident on an end face, in accordance with the present invention.

15 Figs. 22-23 are side views of an optical identification element where light is incident on an end face, in accordance with the present invention.

Figs. 24, illustrations (a)-(c) are side views of an optical identification element having a blazed grating, in accordance with the present invention.

Fig. 25 is a side view of an optical identification element having a coating, in accordance with the present invention.

20 Fig. 26 is a side view of whole and partitioned optical identification element, in accordance with the present invention.

Fig. 27 is a side view of an optical identification element having a grating across an entire dimension, in accordance with the present invention.

25 Fig. 28, illustrations (a)-(c), are perspective views of alternative embodiments for an optical identification element, in accordance with the present invention.

Fig. 29, illustrations (a)-(b), are perspective views of an optical identification element having multiple grating locations, in accordance with the present invention.

Fig. 30, is a perspective view of an alternative embodiment for an optical identification element, in accordance with the present invention.

Fig. 31 is a view an optical identification element having a plurality of gratings located rotationally around the optical identification element, in accordance with the present invention.

5 Fig. 32 illustrations (a)-(e) show various geometries of an optical identification element that may have holes therein, in accordance with the present invention.

Fig. 33 illustrations (a)-(c) show various geometries of an optical identification element that may have teeth thereon, in accordance with the present invention.

10 Fig. 34 illustrations (a)-(c) show various geometries of an optical identification element, in accordance with the present invention.

Fig. 35 is a side view an optical identification element having a reflective coating thereon, in accordance with the present invention.

15 Fig. 36 illustrations (a)-(b) are side views of an optical identification element polarized along an electric or magnetic field, in accordance with the present invention.

Best Mode for Carrying Out the Invention

20 Referring to Fig. 1, a diffraction grating-based optical identification element 8 (or encoded element or coded element) comprises a known optical substrate 10, having an optical diffraction grating 12 disposed (or written, impressed, embedded, imprinted, etched, grown, deposited or otherwise formed) in the volume of or on a surface of a substrate 10. The grating 12 is a periodic or aperiodic variation in the effective refractive index and/or effective optical absorption of at least a portion of the
25 substrate 10.

The optical identification element described herein is the same as that described in Copending Patent Application Serial No. (CyVera Docket No. CV-0038A), filed contemporaneously herewith, which is incorporated herein by reference in its entirety.

In particular, the substrate 10 has an inner region 20 where the grating 12 is located. The inner region 20 may be photosensitive to allow the writing or impressing of the grating 12. The substrate 10 has an outer region 18 which does not have the grating 12 therein.

5 The grating 12 is a combination of one or more individual spatial periodic sinusoidal variations (or components) in the refractive index that are collocated at substantially the same location on the substrate 10 along the length of the grating region 20, each having a spatial period (or pitch) Λ . The resultant combination of these individual pitches is the grating 12, comprising spatial periods (Λ_1 - Λ_n) each
10 representing a bit in the code. Thus, the grating 12 represents a unique optically readable code, made up of bits, where a bit corresponds to a unique pitch Λ within the grating 12. Accordingly, for a digital binary (0-1) code, the code is determined by which spatial periods (Λ_1 - Λ_n) exist (or do not exist) in a given composite grating 12. The code or bits may also be determined by additional parameters (or additional
15 degrees of multiplexing), and other numerical bases for the code may be used, as discussed herein and/or in the aforementioned patent application.

 The grating 12 may also be referred to herein as a composite or collocated grating. Also, the grating 12 may be referred to as a "hologram", as the grating 12 transforms, translates, or filters an input optical signal to a predetermined desired
20 optical output pattern or signal.

 The substrate 10 has an outer diameter D1 and comprises silica glass (SiO_2) having the appropriate chemical composition to allow the grating 12 to be disposed therein or thereon. Other materials for the optical substrate 10 may be used if desired. For example, the substrate 10 may be made of any glass, e.g., silica, phosphate glass,
25 borosilicate glass, or other glasses, or made of glass and plastic, or solely plastic. For high temperature or harsh chemical applications, the optical substrate 10 made of a glass material is desirable. If a flexible substrate is needed, plastic, rubber or polymer-based substrate may be used. The optical substrate 10 may be any material

capable of having the grating 12 disposed in the grating region 20 and that allows light to pass through it to allow the code to be optically read.

The optical substrate 10 with the grating 12 has a length L and an outer diameter D1, and the inner region 20 diameter D. The length L can range from very small "microbeads" (or microelements, micro-particles, or encoded particles), about 5 1-1000 microns or smaller, to larger "macroelements" for larger applications (about 1.0 - 1000 mm or greater). In addition, the outer dimension D1 can range from small (less than 1000 microns) to large (1.0 – 1000 mm and greater). Other dimensions and lengths for the substrate 10 and the grating 12 may be used.

10 The optical substrate 10 with the grating 12 has a length L and an outer diameter D1, and the inner region 20 diameter D. The length L can range from very small (about 1-1000 microns or smaller) to large (about 1.0 - 1000 mm or greater). In addition, the outer dimension D1 can range from small (less than 1000 microns) to large (1.0 – 1000 mm and greater). Other dimensions and lengths for the substrate 10 and the grating 12 may be used. Also, the element may be embedded within or part of 15 a larger substrate or object. The element may also be in the form of a thread or fiber to be weaved into a material.

The grating 12 may have a length L_g of about the length L of the substrate 10. Alternatively, the length L_g of the grating 12 may be shorter than the total length L of 20 the substrate 10, as shown in Fig. 11.

The outer region 18 is made of pure silica (SiO_2) and has a refractive index n_2 of about 1.458 (at a wavelength of about 1553 nm), and the inner grating region 20 of the substrate 10 has dopants, such as germanium and/or boron, to provide a refractive index n_1 of about 1.453, which is less than that of outer region 18 by about 0.005. 25 Other indices of refraction n_1, n_2 for the grating region 20 and the outer region 18, respectively, may be used, if desired, provided the grating 12 can be impressed in the desired grating region 20. For example, the grating region 20 may have an index of refraction that is larger than that of the outer region 18 or grating region 20 may have the same index of refraction as the outer region 18 if desired.

Referring to Fig. 2, an incident light 24 of a wavelength λ , e.g., 532 nm from a known frequency doubled Nd:YAG laser or 632nm from a known Helium-Neon laser, is incident on the grating 12 in the substrate 10. Any other input wavelength λ can be used if desired provided λ is within the optical transmission range of the substrate
5 (discussed more herein and/or in the aforementioned patent application). A portion of the input light 24 passes straight through the grating 12, as indicated by a line 25. The remainder of the input light 24 is reflected by the grating 12, as indicated by a line 27 and provided to a detector 29. The output light 27 may be a plurality of beams, each having the same wavelength λ as the input wavelength λ and each having a different
10 output angle indicative of the pitches (Λ_1 - Λ_n) existing in the grating 12. Alternatively, the input light 24 may be a plurality of wavelengths and the output light 27 may have a plurality of wavelengths indicative of the pitches (Λ_1 - Λ_n) existing in the grating 12. Alternatively, the output light may be a combination of wavelengths and output angles. The above techniques are discussed in more detail herein and/or in
15 the aforementioned patent application.

The detector 29 has the necessary optics, electronics, software and/or firmware to perform the functions described herein. In particular, the detector reads the optical signal 27 diffracted or reflected from the grating 12 and determines the code based on the pitches present or the optical pattern, as discussed more herein or in the
20 aforementioned patent application. An output signal indicative of the code is provided on a line 31.

The encoded element 8 may be used to label any desired item, such as large or small objects, products, solids, powders, liquids, gases, plants, minerals, and/or animals, or any combination of one or more thereof. The label may be used for many
25 different purposes, such as for sorting, tracking, identification, verification, authentication, anti-theft/anti-counterfeit, security/anti-terrorism, forensics, or for other purposes. In a manufacturing environment, the elements 8 may be used to track inventory for production information or sales of goods/products.

For any of the labeled items described herein, the encoded elements 8 may be tiny discrete microbeads (1 to 1000 microns long) embedded into the surface of the item or the encoded element 8 may be a long strand of glass or plastic fiber that is woven, inserted, impressed, or injected into the item being labeled. Alternatively, in the appropriate cases, the diffraction grating 12 may be written or impressed directly into the material, as discussed herein. In any case, the properties of the encoded element 8 do not change. For labeled items that are pliable, bendable, or flexible, the element 8 may be made of a bendable material, such as a polymer or plastic. Also, if the item material is soft or compliant the beads may be pressed, pushed, hammered or shot into the material, either for side reading or end reading, depending on the application.

For any of the embodiments herein, the label on the item can be detected by scanning the item with incident light and detecting the reflected light as discussed herein and/or in the aforementioned patent application. When an element 8 is embedded or attached to an item that is not reflective or transparent to the incident light 24 and reflected light 27, and if the element 8 is not reflective, it may be desirable to illuminate the element from an axial end 8 to achieve best results for code reading.

In general, the encoded elements 8 may be used to label any products or components within a product and may be used for product manufacturing/ production identification.

Referring to Fig. 3, illustrations (a)-(d), encoded elements 8 may be used to label glass or plastic items, such as microscope slides 811, test tubes 813, beakers 815, cookware 817, storage containers and/or covers, multi-well plates, micro-well plates, plastic bags, windshields, windows, glasses, contact lenses, other lenses, optical components, tape, bottles, displays, display cases, watch faces, mirrors, sample or petri dishes, or any other item made of a material that is transparent or substantially transparent to the incident light 24 and reflected light 27 used for read the code in the encoded elements 8. The invention may be used to identify such glass

or plastic items by writing the diffraction grating 12 directly into the material or by embedding into or otherwise attaching the encoded elements 8 to the item. In the case where the code is written directly into the material, the material must have sufficient photosensitivity to allow the diffraction grating 12 to be written into the material with sufficient strength so the code can be optically read. We have found that borosilicate glass has sufficient photosensitivity to support the creation of a diffraction grating 12 therein. Other glasses may be used.

Referring to Fig. 4, illustrations (a) and (b), the encoded elements 8 may be used to label micron size products, such as, microcircuits computer chips, integrated circuits (IC's), or other small products or portions thereof. Referring to Fig. 4, illustration (c), the elements 8 may also be used to label silicon wafers 59 or small portions or regions 57 thereof before being cut into small devices or microcircuits.

Referring to Fig. 5, the elements 8 may be used to label any single or multiple cells 101 that are attached to or otherwise disposed on the element 8. The cells 101 may include: molecules, particles, elements, compounds, organisms, atoms, chemicals, acids, bases, nucleic acids, chemical libraries, DNA, polynucleotides, oligomers, RNA, proteins, peptides, polymers, hydrocarbons, or other cells. The cells 101 may be alive or dead, organic or inorganic, and may be individual or groups or chains of cells and may change or mutate over time.

Referring to Fig. 6, illustrations, (a)-(d), the encoded elements 8 may be used to label a liquid or liquid products located in a container 801 or in an open or closed flowing pipe or conduit 803, 805 respectively. In that case, the elements 8 are mixed with the liquid. In addition, the elements 8 may also be used to label powders, such as powdered detergent, dirt, pulverized coal, gunpowder, anthrax, or any other powders located in a container 807, or in an open or closed flowing pipe or conduit 803,805, respectively. Also, the elements 8 may be used to label or identify any combination of fluids (liquids and/or gases) and/or powders. Also, the elements 8 may be used to label gases, such as gases in containers or gases flowing in a pipe or conduit, or gaseous by-products of reactions, such as combustion exhaust or other exhaust. Also,

the elements 8 may be used to label liquid particles or droplets in gas, such as steam. The elements 8 may be used to track the flow of a liquid, powder, gas, etc. in an industrial plant to determine where the liquid is flowing or has flown.

5 The elements 8 may be removed from a fluid, powder and/or gas solution or mixture other material by electro-magnetic attraction (if the elements are electro-magnetic), skimmed off the surface (if the elements 8 are less dense than the solution, i.e., buoyant or semi-buoyant), or from settling to the bottom of a container (if the elements 8 are more dense than the solution), or by filtering the solution with a strainer or filter.

10 The elements 8 can placed in a fluid or powder and the fluid or powder is used for labeling an item. For example, the elements 8 may be mixed with paint (or other adhesive fluid) and sprayed on an item, such as a car or boat (see Fig. 7, illustrations (b) and (c)) or any other item that can be sprayed or painted. The same may be done with a dry powder that is sprayed on a newly painted or otherwise adhesive surface, or
15 with an adhesive powder that is sprayed on a dry, or painted or adhesive surface.

Referring to Fig. 7, illustrations (a), (b), (c), (f), (g), and (h), in particular, the encoded elements 8 may be used to label large and/or valuable items such as cases 841 (e.g., suitcases, briefcases, garment bags, and the like), cars 831, boats 833, paintings 835, china 837, jewelry 839, and the like. Also, the elements 8 may be used
20 as a way of putting the vehicle identification number (VIN) or other similar identification information in a hidden location and/or in many locations on an item that can only be read by the proper equipment. The elements 8 can be used to label photographs.

Referring to Fig. 7, illustrations (d), (e), and (r), the encoded elements 8 may
25 also be used to label currency 829, coins, bills, or credit cards. Also, the elements 8 may be used an alternative or addition to magnetic strips currently used on many types of cards 825, e.g., access cards, key cards, ID cards, debit cards, credit cards, and the like. In addition, the elements 8 may be used as part of a key 827.

Referring to Fig. 7, illustration (i), the elements 8 may be used to label food containers 847 and the like.

5 Referring to Fig. 7, illustrations (j) and (l), the elements 8 may be used to label building materials 843, e.g., wood, pressboard, composite boards (e.g., made of wood, plastic, and/or metal particles), sheetrock, wallboard, wallpaper, molding, tiles and the like or other building materials. Similarly, the elements 8 may be used to label furniture or other home or office furnishings 845.

10 Referring to Fig. 7, illustrations (m), (o), and (p), the encoded elements 8 may be used to label any animals 649, creatures, people/humans 855, and/or plants, or parts thereof 853. Such a label could be used in addition to or instead of fingerprints, retina scans, DNA or other identification techniques or labels.

Referring to Fig. 7, illustrations (n) and (q), the encoded elements 8 may be used to label documents 857, books 851, and/or packages.

15 Referring to Fig. 7, illustrations (s) and (t), the encoded elements 8 may be used to label weapons, ammunition, explosive devices, guns 819, artillery, bullets 821, mortar, grenades, missiles, torpedoes, projectiles, fireworks, bombs, spacecraft, aircraft, satellites, jet engines, submarines and tanks.

Referring to Fig. 7, illustration (u), the encoded elements 8 may be used to label clothing 823, garments, uniforms, linens, leather, footwear, headgear, or textiles.

20 Referring to Fig. 7, illustration (v), the encoded elements 8 may be used to label storage media, such as compact discs and digital video discs (DVD's), or any other devices that uses light to read information, video or audio tapes tapes, disc drives, and the like.

25 Referring to Fig. 8, the code may be a simple code or may be a more complex code having many pieces of information located in the code. In addition, the code may have checks within the code to ensure the code is read correctly. It can be viewed as a serial digital message, word, or frame consisting of N bits.

In particular, there may be start and stop bits 869, 871, respectively. The start and stop bits may each take up more than one bit location if desired. In addition there

may be an error check portion of the message, such as a check sum or CRC (cyclic redundancy check) having a predetermined number of bits, and a code section 873 having a predetermined number of bits. The error check portion ensures that the code which is obtained from the bead is accurate. Accordingly, having a large number of bits in the element 8 allows for greater statistical accuracy in the code readout and decreases the likelihood of providing an erroneous code. Accordingly, if a code cannot be read without an error, no code will be provided, avoiding an erroneous result. Any known techniques for digital error checking for single or multi-bit errors may be used.

The code section 873 may be broken up into one or more groups of bits, for example, three bit groups 863,865,867, each bit group containing information about the bead itself or the item attached to the bead or how the bead is to be used, or other information. For example, the first bit group 863 may contain information regarding "identifying numbers", such as: lot number, quality control number, model number, serial number, inventory control number; the second bit group 865 may contain "type" information, such as: chemical or cell type, experiment type, item type, animal type; and the third bit group 867 may contain "date" information, such as: manufactured date, experiment date, creation date, initial tracking date. Any other bit groups, number of bit groups, or size of bit groups may be used if desired. Also, additional error or fault checking can be used if desired.

In particular, for a product manufacturing application, the code may have the serial number, the lot number, date of manufacture, etc. or have other information that identifies the item and/or information about the item. For a chemical or assay application, the code may have information about the chemical attached to the bead, the date and/or time of creation of the chemical or experiment, or other information of interest.

Referring to Fig. 9, The reflected light 27, comprises a plurality of beams 26-36 that pass through a lens 37, which provides focused light beams 46-56, respectively, which are imaged onto a CCD camera 60. The lens 37 and the camera

60, and any other necessary electronics or optics for performing the functions described herein, make up the reader 29. Instead of or in addition to the lens 37, other imaging optics may be used to provide the desired characteristics of the optical image/signal onto the camera 60 (e.g., spots, lines, circles, ovals, etc.), depending on the shape of the substrate 10 and input optical signals. Also, instead of a CCD camera other devices may be used to read/capture the output light.

Referring to Fig. 10, the image on the CCD camera 60 is a series of illuminated stripes indicating ones and zeros of a digital pattern or code of the grating 12 in the element 8. Referring to Fig. 11, lines 68 on a graph 70 are indicative of a digitized version of the image of Fig. 10 as indicated in spatial periods (Λ_1 - Λ_n).

Each of the individual spatial periods (Λ_1 - Λ_n) in the grating 12 is slightly different, thus producing an array of N unique diffraction conditions (or diffraction angles) discussed more hereinafter. When the element 8 is illuminated from the side, in the region of the grating 12, at an appropriate input angle, e.g., about 30 degrees, with a single input wavelength λ (monochromatic) source, the diffracted (or reflected) beams 26-36 are generated. Other input angles θ_i may be used if desired, depending on various design parameters as discussed herein and/or in the aforementioned patent application, and provided that a known diffraction equation (Eq. 1 below) is satisfied:

$$\sin(\theta_i) + \sin(\theta_o) = m\lambda / n\Lambda \quad \text{Eq. 1}$$

where Eq. 1 is diffraction (or reflection or scatter) relationship between input wavelength λ , input incident angle θ_i , output incident angle θ_o , and the spatial period Λ of the grating 12. Further, m is the "order" of the reflection being observed, and n is the refractive index of the substrate 10. The value of m=1 or first order reflection is acceptable for illustrative purposes. Eq. 1 applies to light incident on outer surfaces of the substrate 10 which are parallel to the longitudinal axis of the grating (or the k_B vector). Because the angles θ_i, θ_o are defined outside the substrate 10 and because the effective refractive index of the substrate 10 is substantially a common value, the value of n in Eq. 1 cancels out of this equation.

Thus, for a given input wavelength λ , grating spacing Λ , and incident angle of the input light θ_i , the angle θ_o of the reflected output light may be determined.

Solving Eq. 1 for θ_o and plugging in $m=1$, gives:

$$\theta_o = \sin^{-1}(\lambda/\Lambda - \sin(\theta_i)) \quad \text{Eq. 2}$$

5 For example, for an input wavelength $\lambda = 532$ nm, a grating spacing $\Lambda = 0.532$ microns (or 532 nm), and an input angle of incidence $\theta_i = 30$ degrees, the output angle of reflection will be $\theta_o = 30$ degrees. Alternatively, for an input wavelength $\lambda = 632$ nm, a grating spacing $\Lambda = 0.532$ microns (or 532 nm), and an input angle θ_i of 30 degrees, the output angle of reflection θ_o will be at 43.47 degrees, or for an input
10 angle $\theta_i = 37$ degrees, the output angle of reflection will be $\theta_o = 37$ degrees. Any input angle that satisfies the design requirements discussed herein and/or in the aforementioned patent application may be used.

In addition, to have sufficient optical output power and signal to noise ratio, the output light 27 should fall within an acceptable portion of the Bragg envelope (or
15 normalized reflection efficiency envelope) curve 200, as indicated by points 204,206, also defined as a Bragg envelope angle θ_B , as also discussed herein and/or in the aforementioned patent application. The curve 200 may be defined as:

$$I(k_i, k_o) \approx [KD]^2 \sin^2 \left[\frac{(k_i - k_o)D}{2} \right] \quad \text{Eq. 3}$$

where $K = 2\pi\delta n/\lambda$, where, δn is the local refractive index modulation amplitude of the
20 grating and λ is the input wavelength, $\text{sinc}(x) = \sin(x)/x$, and the vectors $k_i = 2\pi\cos(\theta_i)/\lambda$ and $k_o = 2\pi\cos(\theta_o)/\lambda$ are the projections of the incident light and the output (or reflected) light, respectively, onto the line 203 normal to the axial direction of the grating 12 (or the grating vector k_B), D is the thickness or depth of the grating 12 as measured along the line 203 (normal to the axial direction of the grating 12).
25 Other substrate shapes than a cylinder may be used and will exhibit a similar peaked characteristic of the Bragg envelope. We have found that a value for δn of about 10^{-4}

in the grating region of the substrate is acceptable; however, other values may be used if desired.

Rewriting Eq. 3 gives the reflection efficiency profile of the Bragg envelope as:

$$I(k_i, k_o) \approx \left[\frac{2\pi \cdot \delta n \cdot D}{\lambda} \right]^2 \left[\frac{\text{Sin}(x)}{x} \right]^2 \quad \text{Eq. 4}$$

where: $x = (k_i - k_o)D/2 = (\pi D/\lambda) * (\cos \theta_i - \cos \theta_o)$

Thus, when the input angle θ_i is equal to the output (or reflected) angle θ_o (i.e., $\theta_i = \theta_o$), the reflection efficiency I (Eqs. 3 & 4) is maximized, which is at the center or peak of the Bragg envelope. When $\theta_i = \theta_o$, the input light angle is referred to as the Bragg angle as is known. The efficiency decreases for other input and output angles (i.e., $\theta_i \neq \theta_o$), as defined by Eqs. 3 & 4. Thus, for maximum reflection efficiency and thus output light power, for a given grating pitch Λ and input wavelength, the angle θ_i of the input light should be set so that the angle θ_o of the reflected output light equals the input angle θ_i .

Also, as the thickness or diameter D of the grating decreases, the width of the $\text{sin}(x)/x$ function (and thus the width of the Bragg envelope) increases and, the coefficient to or amplitude of the sinc^2 (or $(\text{sin}(x)/x)^2$ function (and thus the efficiency level across the Bragg envelope) also increases, and vice versa. Further, as the wavelength λ increases, the half-width of the Bragg envelope as well as the efficiency level across the Bragg envelope both decrease. Thus, there is a trade-off between the brightness of an individual bit and the number of bits available under the Bragg envelope. Ideally, δn should be made as large as possible to maximize the brightness, which allows D to be made smaller.

From Eq. 3 and 4, the half-angle of the Bragg envelope θ_B is defined as:

$$\theta_B = \frac{\eta \lambda}{\pi D \sin(\theta_i)} \quad \text{Eq. 5}$$

where η is a reflection efficiency factor which is the value for x in the $\text{sinc}^2(x)$ function where the value of $\text{sinc}^2(x)$ has decreased to a predetermined value from the maximum amplitude as indicated by points 204,206 on the curve 200.

We have found that the reflection efficiency is acceptable when $\eta \leq 1.39$. This
5 value for η corresponds to when the amplitude of the reflected beam (i.e., from the $\text{sinc}^2(x)$ function of Eqs. 3 & 4) has decayed to about 50% of its peak value. In particular, when $x = 1.39 = \eta$, $\text{sinc}^2(x) = 0.5$. However, other values for efficiency thresholds or factor in the Bragg envelope may be used if desired.

The beams 26-36 are imaged onto the CCD camera 60 to produce the pattern
10 of light and dark regions 120-132 representing a digital (or binary) code, where light = 1 and dark = 0 (or vice versa). The digital code may be generated by selectively creating individual index variations (or individual gratings) with the desired spatial periods Λ_1 - Λ_n . Other illumination, readout techniques, types of gratings, geometries, materials, etc. may be used as discussed in the aforementioned patent application.

Referring to Fig.12, illustrations (a)-(c), for the grating 12 in a cylindrical
15 substrate 10 having a sample spectral 17 bit code (i.e., 17 different pitches Λ_1 - Λ_{17}), the corresponding image on the CCD (Charge Coupled Device) camera 60 is shown for a digital pattern of 7 bits turned on (10110010001001001); 9 bits turned on of (11000101010100111); all 17 bits turned on of (11111111111111111).

For the images in Fig. 12, the length of the substrate 10 was 450 microns, the
20 outer diameter D_1 was 65 microns, the inner diameter D was 14 microns, δn for the grating 12 was about 10^{-4} , n_1 in portion 20 was about 1.458 (at a wavelength of about 1550 nm), n_2 in portion 18 was about 1.453, the average pitch spacing Λ for the grating 12 was about 0.542 microns, and the spacing between pitches $\Delta\Lambda$ was about
25 0.36 % of the adjacent pitches Λ .

Referring to Fig. 13, illustration (a), the pitch Λ of an individual grating is the axial spatial period of the sinusoidal variation in the refractive index n_1 in the region 20 of the substrate 10 along the axial length of the grating 12 as indicated by a curve

90 on a graph 91. Referring to Fig. 13, illustration (b), a sample composite grating 12 comprises three individual gratings that are co-located on the substrate 10, each individual grating having slightly different pitches, Λ_1 , Λ_2 , Λ_3 , respectively, and the difference (or spacing) $\Delta\Lambda$ between each pitch Λ being about 3.0 % of the period of an adjacent pitch Λ as indicated by a series of curves 92 on a graph 94. Referring to Fig. 13, illustration (c), three individual gratings, each having slightly different pitches, Λ_1 , Λ_2 , Λ_3 , respectively, are shown, the difference $\Delta\Lambda$ between each pitch Λ being about 0.3% of the pitch Λ of the adjacent pitch as shown by a series of curves 95 on a graph 97. The individual gratings in Fig. 13, illustrations (b) and (c) are shown to all start at 0 for illustration purposes; however, it should be understood that, the separate gratings need not all start in phase with each other. Referring to Fig. 13, illustration (d), the overlapping of the individual sinusoidal refractive index variation pitches Λ_1 - Λ_n in the grating region 20 of the substrate 10, produces a combined resultant refractive index variation in the composite grating 12 shown as a curve 96 on a graph 98 representing the combination of the three pitches shown in Fig. 13, illustration (b). Accordingly, the resultant refractive index variation in the grating region 20 of the substrate 10 may not be sinusoidal and is a combination of the individual pitches Λ (or index variation).

The maximum number of resolvable bits N , which is equal to the number of different grating pitches Λ (and hence the number of codes), that can be accurately read (or resolved) using side-illumination and side-reading of the grating 12 in the substrate 10, is determined by numerous factors, including: the beam width w incident on the substrate (and the corresponding substrate length L and grating length L_g), the thickness or diameter D of the grating 12, the wavelength λ of incident light, the beam divergence angle θ_R , and the width of the Bragg envelope θ_B (discussed more in the aforementioned patent application), and may be determined by the equation:

$$N \cong \frac{\eta\beta L}{2D \sin(\theta_i)} \quad \text{Eq. 6}$$

Referring to Fig. 14, instead of having the input light 24 at a single wavelength λ (monochromatic) and reading the bits by the angle θ_0 of the output light, the bits (or grating pitches Λ) may be read/detected by providing a plurality of wavelengths and reading the wavelength spectrum of the reflected output light signal. In this case, there would be one bit per wavelength, and thus, the code is contained in the wavelength information of the reflected output signal.

In this case, each bit (or Λ) is defined by whether its corresponding wavelength falls within the Bragg envelope, not by its angular position within the Bragg envelope 200. As a result, it is not limited by the number of angles that can fit in the Bragg envelope 200 for a given composite grating 12, as in the embodiment discussed hereinbefore. Thus, using multiple wavelengths, the only limitation in the number of bits N is the maximum number of grating pitches Λ that can be superimposed and optically distinguished in wavelength space for the output beam.

Referring to Figs. 14 and 15, illustration (a), the reflection wavelength spectrum ($\lambda_1-\lambda_n$) of the reflected output beam 310 will exhibit a series of reflection peaks 695, each appearing at the same output Bragg angle θ_0 . Each wavelength peak 695 ($\lambda_1-\lambda_n$) corresponds to an associated spatial period ($\Lambda_1-\Lambda_n$), which make up the grating 12.

One way to measure the bits in wavelength space is to have the input light angle θ_i equal to the output light angle θ_0 , which is kept at a constant value, and to provide an input wavelength λ that satisfies the diffraction condition (Eq. 1) for each grating pitch Λ . This will maximize the optical power of the output signal for each pitch Λ detected in the grating 12.

Referring to 15, illustration (b), the transmission wavelength spectrum of the transmitted output beam 330 (which is transmitted straight through the grating 12) will exhibit a series of notches (or dark spots) 696. Alternatively, instead of detecting the reflected output light 310, the transmitted light 330 may be detected at the detector/reader 308. It should be understood that the optical signal levels for the

reflection peaks 695 and transmission notches 696 will depend on the “strength” of the grating 12, i.e., the magnitude of the index variation n in the grating 12.

In Fig. 14, the bits may be detected by continuously scanning the input wavelength. A known optical source 300 provides the input light signal 24 of a coherent scanned wavelength input light shown as a graph 304. The source 300 provides a sync signal on a line 306 to a known reader 308. The sync signal may be a timed pulse or a voltage ramped signal, which is indicative of the wavelength being provided as the input light 24 to the substrate 10 at any given time. The reader 308 may be a photodiode, CCD camera, or other optical detection device that detects when an optical signal is present and provides an output signal on a line 309 indicative of the code in the substrate 10 or of the wavelengths present in the output light, which is directly related to the code, as discussed herein. The grating 12 reflects the input light 24 and provides an output light signal 310 to the reader 308. The wavelength of the input signal is set such that the reflected output light 310 will be substantially in the center 314 of the Bragg envelope 200 for the individual grating pitch (or bit) being read.

Alternatively, the source 300 may provide a continuous broadband wavelength input signal such as that shown as a graph 316. In that case, the reflected output beam 310 signal is provided to a narrow band scanning filter 318 which scans across the desired range of wavelengths and provides a filtered output optical signal 320 to the reader 308. The filter 318 provides a sync signal on a line 322 to the reader, which is indicative of which wavelengths are being provided on the output signal 320 to the reader and may be similar to the sync signal discussed hereinbefore on the line 306 from the source 300. In this case, the source 300 does not need to provide a sync signal because the input optical signal 24 is continuous. Alternatively, instead of having the scanning filter being located in the path of the output beam 310, the scanning filter may be located in the path of the input beam 24 as indicated by the dashed box 324, which provides the sync signal on a line 323.

Alternatively, instead of the scanning filters 318,324, the reader 308 may be a known optical spectrometer (such as a known spectrum analyzer), capable of measuring the wavelength of the output light.

The desired values for the input wavelengths λ (or wavelength range) for the input signal 24 from the source 300 may be determined from the Bragg condition of Eq. 1, for a given grating spacing Λ and equal angles for the input light θ_i and the angle light θ_o . Solving Eq. 1 for λ and plugging in $m=1$, gives:

$$\lambda = \Lambda [\sin(\theta_o) + \sin(\theta_i)] \quad \text{Eq. 7}$$

It is also possible to combine the angular-based code detection with the wavelength-based code detection, both discussed hereinbefore. In this case, each readout wavelength is associated with a predetermined number of bits within the Bragg envelope. Bits (or grating pitches Λ) written for different wavelengths do not show up unless the correct wavelength is used.

Accordingly, the bits (or grating pitches Λ) can be read using one wavelength and many angles, many wavelengths and one angle, or many wavelengths and many angles.

Referring to Fig. 16, the grating 12 may have a thickness or depth D which is comparable or smaller than the incident beam wavelength λ . This is known as a "thin" diffraction grating (or the full angle Bragg envelope is 180 degrees). In that case, the half-angle Bragg envelope θ_B is substantially 90 degrees; however, δn must be made large enough to provide sufficient reflection efficiency, per Eqs. 3 and 4. In particular, for a "thin" grating, $D \cdot \delta n \approx \lambda/2$, which corresponds to a π phase shift between adjacent minimum and maximum refractive index values of the grating 12.

It should be understood that there is still a trade-off discussed hereinbefore with beam divergence angle θ_R and the incident beam width (or length L of the substrate), but the accessible angular space is theoretically now 90 degrees. Also, for maximum efficiency, the phase shift between adjacent minimum and maximum

refractive index values of the grating 12 should approach a π phase shift; however, other phase shifts may be used.

In this case, rather than having the input light 24 coming in at the conventional Bragg input angle θ_i , as discussed hereinbefore and indicated by a dashed line 701, the grating 12 is illuminated with the input light 24 oriented on a line 705 orthogonal to the longitudinal grating vector 705. The input beam 24 will split into two (or more) beams of equal amplitude, where the exit angle θ_o can be determined from Eq. 1 with the input angle $\theta_i=0$ (normal to the longitudinal axis of the grating 12).

In particular, from Eq. 1, for a given grating pitch Λ_1 , the $\pm 1^{\text{st}}$ order beams ($m=+1$ and $m=-1$), corresponds to output beams 700,702, respectively. For the $\pm 2^{\text{nd}}$ order beams ($m=+2$ and $m=-2$), corresponds to output beams 704,706, respectively. The 0^{th} order (undefracted) beam ($m=0$), corresponds to beam 708 and passes straight through the substrate. The output beams 700-708 project spectral spots or peaks 710-718, respectively, along a common plane, shown from the side by a line 709, which is parallel to the upper surface of the substrate 10.

For example, for a grating pitch $\Lambda = 1.0 \text{ um}$, and an input wavelength $\lambda = 400 \text{ nm}$, the exit angles θ_o are $\sim \pm 23.6$ degrees (for $m = \pm 1$), and ± 53.1 degrees (from $m = \pm 2$), from Eq. 1. It should be understood that for certain wavelengths, certain orders (e.g., $m = \pm 2$) may be reflected back toward the input side or otherwise not detectable at the output side of the grating 12.

Alternatively, one can use only the $\pm 1^{\text{st}}$ order ($m = \pm 1$) output beams for the code, in which case there would be only 2 peaks to detect, 712, 714. Alternatively, one can also use any one or more pairs from any order output beam that is capable of being detected. Alternatively, instead of using a pair of output peaks for a given order, an individual peak may be used.

Referring to Fig. 17, if two pitches Λ_1, Λ_2 exist in the grating 12, two sets of peaks will exist. In particular, for a second grating pitch Λ_2 , the $\pm 1^{\text{st}}$ order beams ($m=+1$ and $m=-1$), corresponds to output beams 720,722, respectively. For the $\pm 2^{\text{nd}}$ order beams ($m=+2$ and $m=-2$), corresponds to output beams 724,726, respectively.

The 0th order (un-defracted) beam ($m=0$), corresponds to beam 718 and passes straight through the substrate. The output beams 720-726 corresponding to the second pitch Λ_2 project spectral spots or peaks 730-736, respectively, which are at a different location than the point 710-716, but along the same common plane, shown from the side by the line 709.

Thus, for a given pitch Λ (or bit) in a grating, a set of spectral peaks will appear at a specific location in space. Thus, each different pitch corresponds to a different elevation or output angle which corresponds to a predetermined set of spectral peaks. Accordingly, the presence or absence of a particular peak or set of spectral peaks defines the code.

In general, if the angle of the grating 12 is not properly aligned with respect to the mechanical longitudinal axis of the substrate 10, the readout angles may no longer be symmetric, leading to possible difficulties in readout. With a thin grating, the angular sensitivity to the alignment of the longitudinal axis of the substrate 10 to the input angle θ_i of incident radiation is reduced or eliminated. In particular, the input light can be oriented along substantially any angle θ_i with respect to the grating 12 without causing output signal degradation, due the large Bragg angle envelope. Also, if the incident beam 24 is normal to the substrate 10, the grating 12 can be oriented at any rotational (or azimuthal) angle without causing output signal degradation.

However, in each of these cases, changing the incident angle θ_i will affect the output angle θ_o of the reflected light in a predetermined predictable way, thereby allowing for accurate output code signal detection or compensation.

Referring to Fig. 18, for a thin grating, in addition to multiplexing in the elevation or output angle based on grating pitch Λ , the bits can also be multiplexed in an azimuthal (or rotational) angle θ_a of the substrate. In particular, a plurality of gratings 750,752,754,756 each having the same pitch Λ are disposed in a surface 701 of the substrate 10 and located in the plane of the substrate surface 701. The input light 24 is incident on all the gratings 750,752,754,756 simultaneously. Each of the gratings provides output beams oriented based on the grating orientation. For

example, the grating 750 provides the output beams 764,762, the grating 752 provides the output beams 766,768, the grating 754 provides the output beams 770,772, and the grating 756 provides the output beams 774,776. Each of the output beams provides spectral peaks or spots (similar to that discussed hereinbefore), which are located in a plane 760 that is parallel to the substrate surface plane 701. In this case, a single grating pitch Λ can produce many bits depending on the number of gratings that can be placed at different azimuthal (rotational) angles on the surface of the substrate 10 and the number of output beam spectral peaks that can be spatially and optically resolved/detected. Each bit may be viewed as the presence or absence of a pair of peaks located at a predetermined location in space in the plane 760. Note that this example uses only the $m = +/-1^{st}$ order for each reflected output beam. Alternatively, the detection may also use the $m = +/-2^{nd}$ order. In that case, there would be two additional output beams and peaks (not shown) for each grating (as discussed hereinbefore) that may lie in the same plane as the plane 760 and may be on a concentric circle outside the circle 760.

In addition, the azimuthal multiplexing can be combined with the elevation or output angle multiplexing discussed hereinbefore to provide two levels of multiplexing. Accordingly, for a thin grating, the number of bits can be multiplexed based on the number of grating pitches Λ and/or geometrically by the orientation of the grating pitches.

Furthermore, if the input light angle θ_i is normal to the substrate 10, the edges of the substrate 10 no longer scatter light from the incident angle into the "code angular space", as discussed herein and/or in the aforementioned patent application.

Also, in the thin grating geometry, a continuous broadband wavelength source may be used as the optical source if desired.

Referring to Fig. 19, instead of or in addition to the pitches Λ in the grating 12 being oriented normal to the longitudinal axis, the pitches may be created at a angle θ_g . In that case, when the input light 24 is incident normal to the surface 792, will produce a reflected output beam 790 having an angle θ_o determined by Eq. 1 as

adjusted for the blaze angle θ_g . This can provide another level of multiplexing bits in the code.

Referring to Fig. 20, instead of using an optical binary (0-1) code, an additional level of multiplexing may be provided by having the optical code use other numerical bases, if intensity levels of each bit are used to indicate code information. This could be achieved by having a corresponding magnitude (or strength) of the refractive index change (δn) for each grating pitch Λ . Four intensity ranges are shown for each bit number or pitch Λ , providing for a Base-4 code (where each bit corresponds to 0,1,2, or 3). The lowest intensity level, corresponding to a 0, would exist when this pitch Λ is not present in the grating 12. The next intensity level would occur when a first low level δn_1 exists in the grating that provides an output signal within the intensity range corresponding to a 1. The next intensity level would occur when a second higher level δn_2 exists in the grating 12 that provides an output signal within the intensity range corresponding to a 2. The next intensity level would occur when a third higher level δn_3 exists in the grating 12 that provides an output signal within the intensity range corresponding to a 3.

Referring to Fig. 21, the input light 24 may be incident on the substrate 10 on an end face 600 of the substrate 10. In that case, the input light 24 will be incident on the grating 12 having a more significant component of the light (as compared to side illumination discussed hereinbefore) along the longitudinal grating axis 207 of the grating (along the grating vector k_B), as shown by a line 602. The light 602 reflects off the grating 12 as indicated by a line 604 and exits the substrate as output light 608. Accordingly, it should be understood by one skilled in the art that the diffraction equations discussed hereinbefore regarding output diffraction angle θ_o also apply in this case except that the reference axis would now be the grating axis 207. Thus, in this case, the input and output light angles θ_i, θ_o , would be measured from the grating axis 207 and length L_g of the grating 12 would become the thickness or depth D of the grating 12. As a result, a grating 12 that is 400 microns long, would result in the Bragg envelope 200 being narrow. It should be understood that because the values of

n1 and n2 are close to the same value, the slight angle changes of the light between the regions 18,20 are not shown herein.

In the case where incident light 610 is incident along the same direction as the grating vector (Kb) 207, i.e., $\theta_i=0$ degrees, the incident light sees the whole length Lg of the grating 12 and the grating provides a reflected output light angle $\theta_o = 0$ degrees, and the Bragg envelope 612 becomes extremely narrow, as the narrowing effect discussed above reaches a limit. In that case, the relationship between a given pitch Λ in the grating 12 and the wavelength of reflection λ is governed by a known "Bragg grating" relation:

10

$$\lambda = 2 n_{eff} \Lambda \quad \text{Eq. 8}$$

where n_{eff} is the effective index of refraction of the substrate, λ is the input (and output wavelength) and Λ is the pitch. This relation, as is known, may be derived from Eq. 1 where $\theta_i = \theta_o = 90$ degrees.

15

In that case, the code information is readable only in the spectral wavelength of the reflected beam, similar to that discussed hereinbefore for wavelength based code reading. Accordingly, the input signal in this case may be a scanned wavelength source or a broadband wavelength source. In addition, as discussed hereinbefore for wavelength based code reading, the code information may be obtained in reflection from the reflected beam 614 or in transmission by the transmitted beam 616 that passes through the grating 12.

20

It should be understood that for shapes of the substrate 10 or element 8 other than a cylinder, the effect of various different shapes on the propagation of input light through the element 8, substrate 10, and/or grating 12, and the associated reflection angles, can be determined using known optical physics including Snell's Law, shown below:

25

$$n_{in} \sin \theta_{in} = n_{out} \sin \theta_{out} \quad \text{Eq. 9}$$

where n_{in} is the refractive index of the first (input) medium, and n_{out} is the refractive index of the second (output) medium, and θ_{in} and θ_{out} are measured from a line 620 normal to an incident surface 622.

Referring to Fig. 22, if the value of n_1 in the grating region 20 is greater than the value of n_2 in the non-grating region 18, the grating region 20 of the substrate 10 will act as a known optical waveguide for certain wavelengths. In that case, the grating region 20 acts as a "core" along which light is guided and the outer region 18 acts as a "cladding" which helps confine or guide the light. Also, such a waveguide will have a known "numerical aperture" (θ_{na}) that will allow light that is within the aperture θ_{na} to be directed or guided along the grating axis 207 and reflected axially off the grating 12 and returned and guided along the waveguide. In that case, the grating 12 will reflect light having the appropriate wavelengths equal to the pitches Λ present in the grating 12 back along the region 20 (or core) of the waveguide, and pass the remaining wavelengths of light as the light 632. Thus, having the grating region 20 act as an optical waveguide for wavelengths reflected by the grating 12 allows incident light that is not aligned exactly with the grating axis 207 to be guided along and aligned with the grating 12 axis 207 for optimal grating reflection.

If an optical waveguide is used any standard waveguide may be used, e.g., a standard telecommunication single mode optical fiber (125 micron diameter or 80 micron diameter fiber with about a 8-10 micron diameter), or a larger diameter waveguide (greater than 0.5 mm diameter), such as is describe in U.S. Patent Application, Serial No. 09/455,868, filed December 6, 1999, entitled "Large Diameter Waveguide, Grating". Further, any type of optical waveguide may be used for the optical substrate 10, such as, a multi-mode, birefringent, polarization maintaining, polarizing, multi-core, multi-cladding, or microstructured optical waveguide, or a flat or planar waveguide (where the waveguide is rectangular shaped), or other waveguides.

Referring to Fig. 23, if the grating 12 extends across the entire dimension D of the substrate, the substrate 10 does not behave as a waveguide for the incident or reflected light and the incident light 24 will be diffracted (or reflected) as indicated by lines 642, and the codes detected as discussed hereinbefore for the end-incidence

condition discussed hereinbefore with Fig. 45, and the remaining light 640 passes straight through.

Referring to Fig. 24, illustrations (a)-(c), in illustration (a), for the end illumination condition, if a blazed or angled grating is used, as discussed
5 hereinbefore, the input light 24 is coupled out of the substrate 10 at a known angle as shown by a line 650. Referring to Fig. 24, illustration (b), alternatively, the input light 24 may be incident from the side and, if the grating 12 has the appropriate blaze angle, the reflected light will exit from the end face 652 as indicated by a line 654. Referring to Fig. 24, illustration (c), the grating 12 may have a plurality of different
10 pitch angles 660,662, which reflect the input light 24 to different output angles as indicated by lines 664, 666. This provides another level of multiplexing (spatially) additional codes, if desired.

The grating 12 may be impressed in the substrate 10 by any technique for writing, impressed, embedded, imprinted, or otherwise forming a diffraction grating
15 in the volume of or on a surface of a substrate 10. Examples of some known techniques are described in US Patent No. 4,725,110 and 4,807,950, entitled "Method for Impressing Gratings Within Fiber Optics", to Glenn et al; and US Patent No. 5,388,173, entitled "Method and Apparatus for Forming Aperiodic Gratings in Optical Fibers", to Glenn, respectively, and US Patent 5,367,588, entitled "Method of
20 Fabricating Bragg Gratings Using a Silica Glass Phase Grating Mask and Mask Used by Same", to Hill, and US Patents 3,916,182, entitled "Periodic Dielectric Waveguide Filter", Dabby et al, and US Patent 3,891,302, entitled "Method of Filtering Modes in Optical Waveguides", to Dabby et al, which are all incorporated herein by reference to the extent necessary to understand the present invention.

25 Alternatively, instead of the grating 12 being impressed within the substrate material, the grating 12 may be partially or totally created by etching or otherwise altering the outer surface geometry of the substrate to create a corrugated or varying surface geometry of the substrate, such as is described in US Patent 3,891,302, entitled "Method of Filtering Modes in Optical Waveguides", to Dabby et al, which is

incorporated herein by reference to the extent necessary to understand the present invention, provided the resultant optical refractive profile for the desired code is created.

5 Further, alternatively, the grating 12 may be made by depositing dielectric layers onto the substrate, similar to the way a known thin film filter is created, so as to create the desired resultant optical refractive profile for the desired code.

10 The substrate 10 (and/or the element 8) may have end-view cross-sectional shapes other than circular, such as square, rectangular, elliptical, clam-shell, D-shaped, or other shapes, and may have side-view sectional shapes other than rectangular, such as circular, square, elliptical, clam-shell, D-shaped, or other shapes. Also, 3D geometries other than a cylinder may be used, such as a sphere, a cube, a pyramid or any other 3D shape. Alternatively, the substrate 10 may have a geometry that is a combination of one or more of the foregoing shapes.

15 The shape of the element 8 and the size of the incident beam may be made to minimize any end scatter off the end face(s) of the element 8, as is discussed herein and/or in the aforementioned patent application. Accordingly, to minimize such scatter, the incident beam 24 may be oval shaped where the narrow portion of the oval is smaller than the diameter D_1 , and the long portion of the oval is smaller than the length L of the element 8. Alternatively, the shape of the end faces may be rounded or
20 other shapes or may be coated with an antireflective coating.

It should be understood that the size of any given dimension for the region 20 of the grating 12 may be less than any corresponding dimension of the substrate 10. For example, if the grating 12 has dimensions of length L_g , depth D_g , and width W_g , and the substrate 12 has different dimensions of length L , depth D , and width W , the
25 dimensions of the grating 12 may be less than that of the substrate 12. Thus, the grating 12, may be embedded within or part of a much larger substrate 12. Also, the element 8 may be embedded or formed in or on a larger object for identification of the object.

The dimensions, geometries, materials, and material properties of the substrate 10 are selected such that the desired optical and material properties are met for a given application. The resolution and range for the optical codes are scalable by controlling these parameters as discussed herein and/or in the aforementioned patent application.

Referring to Fig. 25, the substrate 10 may have an outer coating 799, such as a polymer or other material that may be dissimilar to the material of the substrate 10, provided that the coating 799 on at least a portion of the substrate, allows sufficient light to pass through the substrate for adequate optical detection of the code. The coating 799 may be on any one or more sides of the substrate 10. Also, the coating 799 may be a material that causes the element 8 to float or sink in certain fluids (liquid and/or gas) solutions.

Also, the substrate 10 may be made of a material that is less dense than certain fluid (liquids and/or gas) solutions, thereby allowing the elements 8 to float or be buoyant or partially buoyant. Also, the substrate may be made of a porous material, such as controlled pore glass (CPG) or other porous material, which may also reduce the density of the element 8 and may make the element 8 buoyant or partially-buoyant in certain fluids.

Referring to Fig. 26, the grating 12 is axially spatially invariant. As a result, the substrate 10 with the grating 12 (shown as a long substrate 21) may be axially subdivided or cut into many separate smaller substrates 30-36 and each substrate 30-36 will contain the same code as the longer substrate 21 had before it was cut. The limit on the size of the smaller substrates 30-36 is based on design and performance factors discussed herein and/or in the aforementioned patent application.

Referring to Fig. 27, one purpose of the outer region 18 (or region without the grating 12) of the substrate 10 is to provide mechanical or structural support for the inner grating region 20. Accordingly, the entire substrate 10 may comprise the grating 12, if desired. Alternatively, the support portion may be completely or partially beneath, above, or along one or more sides of the grating region 20, such as in a

planar geometry, or a D-shaped geometry, or other geometries, as described herein and/or in the aforementioned patent application. The non-grating portion 18 of the substrate 10 may be used for other purposes as well, such as optical lensing effects or other effects (discussed herein or in the aforementioned patent application). Also, the end faces of the substrate 10 need not be perpendicular to the sides or parallel to each other. However, for applications where the elements 8 are stacked end-to-end, the packing density may be optimized if the end faces are perpendicular to the sides.

Referring to Figs. 28, illustrations (a)-(c), two or more substrates 10,250, each having at least one grating therein, may be attached together to form the element 8, e.g., by an adhesive, fusing or other attachment techniques. In that case, the gratings 12,252 may have the same or different codes.

Referring to Figs. 29, illustrations (a) and (b), the substrate 10 may have multiple regions 80,90 and one or more of these regions may have gratings in them. For example, there may be gratings 12,252 side-by-side (illustration (a)), or there may be gratings 82-88, spaced end-to-end (illustration (b)) in the substrate 10.

Referring to Fig. 30, the length L of the element 8 may be shorter than its diameter D, thus, having a geometry such as a plug, puck, wafer, disc or plate.

Referring to Fig. 31, to facilitate proper alignment of the grating axis with the angle θ_i of the input beam 24, the substrate 10 may have a plurality of the gratings 12 having the same codes written therein at numerous different angular or rotational (or azimuthal) positions of the substrate 10. In particular, two gratings 550, 552, having axial grating axes 551, 553, respectively may have a common central (or pivot or rotational) point where the two axes 551,553 intersect. The angle θ_i of the incident light 24 is aligned properly with the grating 550 and is not aligned with the grating 552, such that output light 555 is reflected off the grating 550 and light 557 passes through the grating 550 as discussed herein. If the element 8 is rotated as shown by the arrows 559, the angle θ_i of incident light 24 will become aligned properly with the grating 552 and not aligned with the grating 550 such that output light 555 is reflected off the grating 552 and light 557 passes through the grating 552. When multiple

gratings are located in this rotational orientation, the bead may be rotated as indicated by a line 559 and there may be many angular positions that will provide correct (or optimal) incident input angles θ_i to the grating. While this example shows a circular cross-section, this technique may be used with any shape cross-section.

5 Referring to Fig. 32, illustrations (a), (b), (c), (d), and (e) the substrate 10 may have one or more holes located within the substrate 10. In illustration (a), holes 560 may be located at various points along all or a portion of the length of the substrate 10. The holes need not pass all the way through the substrate 10. Any number, size and spacing for the holes 560 may be used if desired. In illustration (b), holes 572
10 may be located very close together to form a honeycomb-like area of all or a portion of the cross-section. In illustration (c), one (or more) inner hole 566 may be located in the center of the substrate 10 or anywhere inside of where the grating region(s) 20 are located. The inner hole 566 may be coated with a reflective coating 573 to reflect light to facilitate reading of one or more of the gratings 12 and/or to reflect light diffracted
15 off one or more of the gratings 12. The incident light 24 may reflect off the grating 12 in the region 20 and then reflect off the surface 573 to provide output light 577. Alternatively, the incident light 24 may reflect off the surface 573, then reflect off the grating 12 and provide the output light 575. In that case the grating region 20 may run axially or circumferentially 571 around the substrate 10. In illustration (d), the holes
20 579 may be located circumferentially around the grating region 20 or transversely across the substrate 10. In illustration (e), the grating 12 may be located circumferentially around the outside of the substrate 10, and there may be holes 574 inside the substrate 10.

Referring to Fig. 33, illustrations (a), (b), and (c), the substrate 10 may have
25 one or more protruding portions or teeth 570, 578, 580 extending radially and/or circumferentially from the substrate 10. Alternatively, the teeth 570, 578, 580 may have any other desired shape.

Referring to Fig. 34, illustrations (a), (b), (c) a D-shaped substrate, a flat-sided substrate and an eye-shaped (or clam-shell or teardrop shaped) substrate 10,

respectively, are shown. Also, the grating region 20 may have end cross-sectional shapes other than circular and may have side cross-sectional shapes other than rectangular, such as any of the geometries described herein for the substrate 10. For example, the grating region 20 may have a oval cross-sectional shape as shown by dashed lines 581, which may be oriented in a desired direction, consistent with the teachings herein. Any other geometries and dimensions for the substrate 10 or the grating region 20 may be used if desired, as described herein. For example, other dimensions that we have found useful are $D_1 =$ about 25-30 microns, and $D =$ about 6-8 microns and length $L =$ about 230-260 microns. Any other dimensions may be used if desired, provided it meets the performance requirements of the application.

Referring to Fig. 35, at least a portion of a side of the substrate 10 may be coated with a reflective coating to allow incident light 510 to be reflected back to the same side from which the incident light came, as indicated by reflected light 512.

Referring to Fig. 36, illustrations (a) and (b), alternatively, the substrate 10 can be electrically and/or magnetically polarized, by a dopant or coating, which may be used to ease handling and/or alignment or orientation of the substrate 10 and/or the grating 12, or used for other purposes. Alternatively, the bead may be coated with conductive material, e.g., metal coating on the inside of a hollow substrate, or metallic dopant inside the substrate. In these cases, such materials can cause the substrate 10 to align in an electric or magnetic field. Alternatively, the substrate can be doped with an element or compound that fluoresces or glows under appropriate illumination, e.g., a rare earth dopant, such as Erbium, or other rare earth dopant or fluorescent or luminescent molecule. In that case, such fluorescence or luminescence may aid in locating and/or aligning substrates.

Referring to Figs. 37-40, in addition, the beads 8 may be used to track and/or identify drugs, or other pharmaceutical or health care products or cosmetics. Such labeling provides product identification at the pill (or liquid) level, which provides traceability of these products to their manufacturer, thereby reducing counterfeit products in the marketplace.

Referring to Fig. 37, 38, one or more beads 8 can be located inside and/or on the outer surface of a pill or capsule, e.g., a solid/powder pill or a liquid/gel/fluid pill. The beads may be inserted into the pill manufacturing process at a convenient point, such as when the pill is in a wet or dry granular stage in the process. Alternatively,
5 one or more beads 8 may be placed in the outer coating of the pills. Referring to Fig. 41, alternatively, the beads 8 may be disposed within a purely liquid medicine.

Referring to Figs. 42, 43, alternatively, one or more of the beads 8 may be placed in a container for the pills, such as a blister pack 903, pill bottle 905, or other pill container.

10 Alternatively, the beads 8 may be coated with a material that allows the body to pass them or to reduce interaction with the body, or may be made of a material that is chewable or dissolves in the body or made of a material that will not harm the body.

Referring to Figs. 39,40,41,42,43, alternatively, the diffraction grating 12 may be embedded or written into the outer surface of the pills, or in a membrane or coating
15 surrounding part or all of the pill, or in the case of a capsule-type pill, the diffraction grating 12 may be disposed directly in the casing of the capsule. Alternatively, the grating 12 may be embedded directly in the container itself, such as a blister pack 903 (Fig. 42) or other pill container 905 (Fig. 43).

In the case where beads 8 are embedded in the item, the beads can be
20 identified by a destroying the item or a portion thereof to obtain the beads 8. For example, in the case of a pill, the pill may be placed in a solution that dissolves the pill but does not dissolve the beads 8. For example, for a glass bead, hot sulfuric acid or other acid may be used to dissolve the pill but will not harm the bead. For beads made of other materials, such as polymers, hot water or other solutions may be used
25 to dissolve the pill. Once the pill has been dissolved, the liquid containing the dissolved pill and the beads may be pipetted into a bead reader to read the bead codes, such as that described in the aforementioned referenced US Patent Applications. Any type of reader capable of reading the beads may be used. Alternatively, the liquid may

be poured through a filter to isolate the beads then put into a bead reader to read the bead codes.

In addition, the digital code lends itself naturally to known covert, anti-counterfeit, and/or anti-theft type encoding, authentication, and identification techniques for items. For example, the code may contain an encrypted code that only the manufacturer can read and understand with the proper decryption. Also, a plurality of beads having different codes may be placed in or on a single item and all the codes would be read together or in a certain order for them to obtain the intended tracking, identification or authentication information. Alternatively, one of the codes may be a key to de-encrypt the codes on the other beads in the same item. Also, the codes may constantly be updated, e.g., rolling codes, or any combination of private and/or public key encryption may be used. Any other use of a bead combination and/or encryption/decryption techniques may be used if desired.

Some non-limiting examples of digital encryption techniques are described in the following patents, each of which are incorporated herein by reference in their entirety.

RE36,752	Cryptographic authentication of transmitted messages using pseudorandom numbers
5,952,937	System and method of updating communications in a security system
5,940,002	Security system with random number remote communication
RE36,181	Pseudorandom number generation and cryptographic authentication
5,783,994	Vehicle security system with combined key fob and keypad anti-driveaway protection
5,757,923	Method of generating secret identification numbers
5,696,828	Random number generating system and process based on chaos
5,649,014	Pseudorandom composition-based cryptographic authentication process
5,619,575	Pseudorandom composition-based cryptographic authentication process
5,598,476	Random clock composition-based cryptographic authentication process and locking system
5,398,284	Cryptographic encoding process
5,377,270	Cryptographic authentication of transmitted messages using pseudorandom numbers
5,363,448	Pseudorandom number generation and cryptographic authentication

Also see, Numerical Recipes, The Art of Scientific Computing, by William H. Press, et al, Cambridge University Press; 1986; Basic Methods of Cryptography by Jan C. A. van der Lubbe, et al, Cambridge Univ. Press 1998; Applied Cryptography: Protocols, Algorithms, and Source Code in C, by Bruce Schneier, 5 which are incorporated herein by reference in their entirety. Further, as discussed hereinbefore, the code(s) may contain lot or batch numbers, date codes, and/or manufacturer codes. One of the additional security benefits of using encrypted data is that the item manufacturer (e.g., drug company, explosives company, etc) is the only one who knows the meaning of the bead codes, so even the bead code manufacturer 10 will not know what the code represents.

Any of the labeling techniques described herein for labeling items may be used solely with the encoded elements or encoding technique of the present invention or in combination with other labeling, encoding, tracking, identification, authentication, or sorting technology, such as bar codes, RFID, other technologies.

15 Unless otherwise specifically stated herein, the term "microbead" is used herein as a label and does not restrict any embodiment or application of the present invention to certain dimensions, materials and/or geometries.

The dimensions and geometries for any of the embodiments described herein are merely for illustrative purposes and, as such, any other dimensions may be used if 20 desired, depending on the application, size, performance, manufacturing requirements, or other factors, in view of the teachings herein.

It should be understood that, unless stated otherwise herein, any of the features, characteristics, alternatives or modifications described regarding a particular embodiment herein may also be applied, used, or incorporated with any other 25 embodiment described herein. Also, the drawings herein are not drawn to scale.

Although the invention has been described and illustrated with respect to exemplary embodiments thereof, the foregoing and various other additions and omissions may be made therein and thereto without departing from the spirit and scope of the present invention.

30

Claims**What is claimed is:**

1. An optical identification element for identifying an item, comprising:
a substrate having at least one diffraction grating disposed therein, said grating
5 having a resultant refractive variation at a grating location;
said grating providing an output optical signal indicative of a code when
illuminated by an incident light signal propagating in free space; and
the element being at least partially disposed on the item.
2. The apparatus of claim 1 wherein said refractive index variation
10 comprises at least one refractive index pitch superimposed at said grating location.
3. The apparatus of claim 1 wherein said refractive index variation
comprises a plurality of refractive index pitches superimposed at said grating location.
4. The apparatus of claim 1 wherein said substrate is made of a material
selected from the group: glass, silica, plastic, rubber, and polymer.
- 15 5. The apparatus of claim 1 wherein said code comprises a plurality of
digital bits.
6. The apparatus of claim 1 wherein said code comprises at least a
predetermined number of bits, said number being: 3, 5, 7, 9, 10, 12, 14, 16, 18, 20, 24,
28, 30, 40, 50, or 100.
- 20 7. The apparatus of claim 1 wherein said code comprises a plurality of
bits, each bit having a plurality of states.
8. The apparatus of claim 1 wherein said code comprises a plurality of
bits, each bit having a corresponding spatial location and each bit in said code having
a value related to the intensity of said output optical signal at the spatial location of
25 each bit.
9. The apparatus of claim 14 wherein the value of said intensity is related
to the magnitude of refractive index variation of a corresponding refractive index
pitch in said grating.

10. The apparatus of claim 1 wherein said code comprises a plurality of digital bits, each bit having a corresponding spatial location and each bit in said code having a binary value related to the intensity of said output optical signal at the spatial location of each bit.

5 11. The apparatus of claim 10 wherein the value of said intensity is related to the presence or absence of a corresponding refractive index pitch in said grating.

12. The apparatus of claim 1 wherein said incident light comprises a single wavelength.

10 13. The apparatus of claim 1 wherein said incident light comprises a plurality of wavelengths or a single wavelength scanned over a predetermined wavelength range.

14. The apparatus of claim 13 wherein said code comprises a plurality of bits, and each bit in said code having a value related to the intensity of said output optical signal at a wavelength corresponding to each bit.

15 15. The apparatus of claim 14 wherein the value of said intensity is related to the magnitude of refractive index variation of a corresponding refractive index pitch in said grating.

20 16. The apparatus of claim 13 wherein said code comprises a plurality of digital bits, and each bit in said code having a binary value related to the intensity of said output optical signal at the wavelength corresponding to each bit.

17. The apparatus of claim 16 wherein the value of said intensity is related to the presence or absence of a corresponding refractive index pitch in said grating.

18. The apparatus of claim 1 wherein said substrate has a length that is less than about 500 microns.

25 19. The apparatus of claim 1 wherein said substrate has a diameter that is less than about 125 microns.

20. The apparatus of claim 1 wherein said substrate has a reflective coating disposed thereon.

21. The apparatus of claim 1 wherein said substrate has a coating disposed on at least a portion of said substrate, at least a portion of said coating being made of a material that allows sufficient amount of said incident light signal to pass through said material to allow detection of said code.

5 22. The apparatus of claim 1 wherein said substrate has a coating material disposed on at least a portion of said substrate, said coating comprising a polymer.

23. The apparatus of claim 1 wherein said substrate has a magnetic or electric charge polarization.

10 24. The apparatus of claim 1 wherein said substrate has geometry having holes therein or having protruding sections therein.

25. The apparatus of claim 1 wherein at least a portion of said substrate has an end cross sectional geometry selected from the group: circular, square, rectangular, elliptical, clam-shell, D-shaped, and polygon.

15 26. The apparatus of claim 1 wherein at least a portion of said substrate has a side view geometry selected from the group: circular, square, rectangular, elliptical, clam-shell, D-shaped, and polygon.

27. The apparatus of claim 1 wherein at least a portion of said substrate has a 3-D shape selected from the group: a cylinder, a sphere, a cube, and a pyramid.

20 28. The apparatus of claim 1 wherein said substrate has a grating region where said grating is located and a non-grating region where said grating is not located; and wherein said substrate has a plurality of grating regions.

25 29. The apparatus of claim 1 wherein said substrate has a grating region where said grating is located and a non-grating region where said grating is not located; and wherein said grating region has a refractive index that is greater than that of said non-grating region.

30. The apparatus of claim 1 wherein said substrate has a grating region where said grating is located and a non-grating region where said grating is not located; and wherein said grating region has a refractive index that is not greater than that of said non-grating region.

31. The apparatus of claim 1 wherein said incident light is incident on said substrate along a longitudinal grating axis of said grating.

32. The apparatus of claim 1 wherein said incident light is incident on said substrate at an angle to a longitudinal grating axis of said grating.

5 33. The apparatus of claim 1 wherein said incident light comprises laser light.

34. The apparatus of claim 1 wherein said grating comprises a thin grating or a blazed grating.

10 35. The apparatus of claim 1 wherein said substrate comprises a plurality of said gratings.

36. The apparatus of claim 1 wherein said substrate comprises a plurality of said gratings each at different locations within said substrate.

37. The apparatus of claim 1 wherein said substrate comprises a particle or bead.

15 38. The apparatus of claim 1 wherein at least a portion of said substrate is disposed on an outer surface of the item.

39. The apparatus of claim 1 wherein said substrate is disposed within said item and said item is made of a material that allows said code to be detected from output signal.

20 40. The apparatus of claim 1, where the item is selected from the group, comprising: large or small objects, products, solids, powders, liquids, gases, plants, currency, ID cards, drugs, minerals, cells and/or animals.

41. An item having a optical identification element disposed therein, comprising:
25 a substrate having at least one diffraction grating disposed therein, said grating having a resultant refractive index variation at a grating location;
said grating providing an output optical signal indicative of a code when illuminated by an incident light signal propagating in free space; and
said code identifying the item.

42. The apparatus of claim 41 wherein said refractive index variation comprises at least one refractive index pitch superimposed at said grating location.

43. The apparatus of claim 41 wherein said refractive index variation comprises a plurality of refractive index pitches superimposed at said grating location.

5 44. The apparatus of claim 1 wherein said substrate comprises a particle or bead.

45. The apparatus of claim 41, where the item is selected from the group, comprising: large or small objects, products, solids, powders, liquids, gases, plants, currency, ID cards, drugs, minerals, cells and/or animals.

10 46. A method of reading a code associated with an optical identification element that is disposed on an item, the element having a diffraction grating having a resultant refractive index variation at a grating location, comprising:

illuminating said element with incident light, said grating providing an output light signal indicative of the code; and

15 reading said output light signal and detecting said code therefrom.

47. The method of claim 46 wherein said refractive index variation comprises at least one refractive index pitch superimposed at said grating location.

48. The method of claim 46 wherein said refractive index variation comprises a plurality of refractive index pitches superimposed at said grating location.

20 49. The method of claim 46 wherein said element comprises a particle or bead.

50. The method of claim 46, where the item is selected from the group, comprising: large or small objects, products, solids, powders, liquids, gases, plants, currency, ID cards, drugs, minerals, cells and/or animals.

25 51. A method for labeling an item, comprising:

obtaining a substrate having at least one diffraction grating disposed therein, said grating having a resultant refractive variation at a grating location, said grating providing an output optical signal indicative of a code when illuminated by an incident light signal propagating in free space; and

said substrate being at least partially disposed on the item.

52. The method of claim 51 wherein said refractive index variation comprises at least one refractive index pitch superimposed at said grating location.

53. The apparatus of claim 51 wherein said refractive index variation
5 comprises a plurality of refractive index pitches superimposed at said grating location.

54. The method of claim 51 wherein said substrate is disposed within said item.

55. The method of claim 51 wherein said substrate comprises a particle or bead.

10 56. The method of claim 51, where the item is selected from the group, comprising: large or small objects, products, solids, powders, liquids, gases, plants, currency, ID cards, drugs, minerals, cells and/or animals.

15 57. The method of claim 51, where said code comprises a digital code indicative of information relating to: identity, type of item, lot number, manufacturer, serial number, date code, or code accuracy.

58. The method of claim 51, wherein said code is an encrypted code.

59. The method of claim 46, wherein said code is an encrypted code.

20 60. The method of claim 46, where said code comprises a digital code indicative of information relating to: identity, type of item, lot number, manufacturer, serial number, date code, or code accuracy.

61. The apparatus of claim 41, wherein said code is an encrypted code.

62. The apparatus of claim 41, where said code comprises a digital code indicative of information relating to: identity, type of item, lot number, manufacturer, serial number, date code, or code accuracy.

25 63. The apparatus of claim 1, wherein said code is an encrypted code.

64. The apparatus of claim 1, where said code comprises a digital code indicative of information relating to: identity, type of item, lot number, manufacturer, serial number, date code, or code accuracy.

65. A method for labeling a drug, comprising:

obtaining an optical identification element having at least one diffraction grating disposed therein, the grating having at least one refractive index pitch superimposed at a common location;

5 the grating providing an output optical signal when illuminated by an incident light signal; and

the optical output signal being indicative of a code; and

the element being at least partially disposed in the drug.

66. The apparatus of claim 1, where said item is a drug and said drug is selected from the group, comprising: large or small pills, capsules, liquid medicine, and powdered medicine.

67. The apparatus of claim 41, where said item is a drug and said drug is selected from the group, comprising: large or small pills, capsules, liquid medicine, and powdered medicine.

68. The method of claim 46, where said item is a drug and said drug is selected from the group, comprising: large or small pills, capsules, liquid medicine, and powdered medicine.

69. The method of claim 51, where said item is a drug and said drug is selected from the group, comprising: large or small pills, capsules, liquid medicine, and powdered medicine.

20

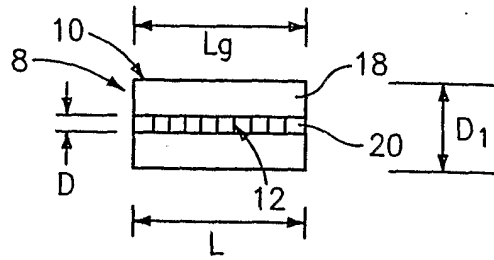

FIG. 1

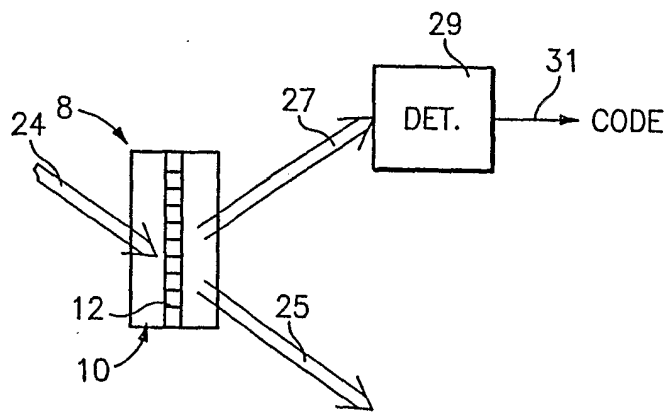

FIG. 2

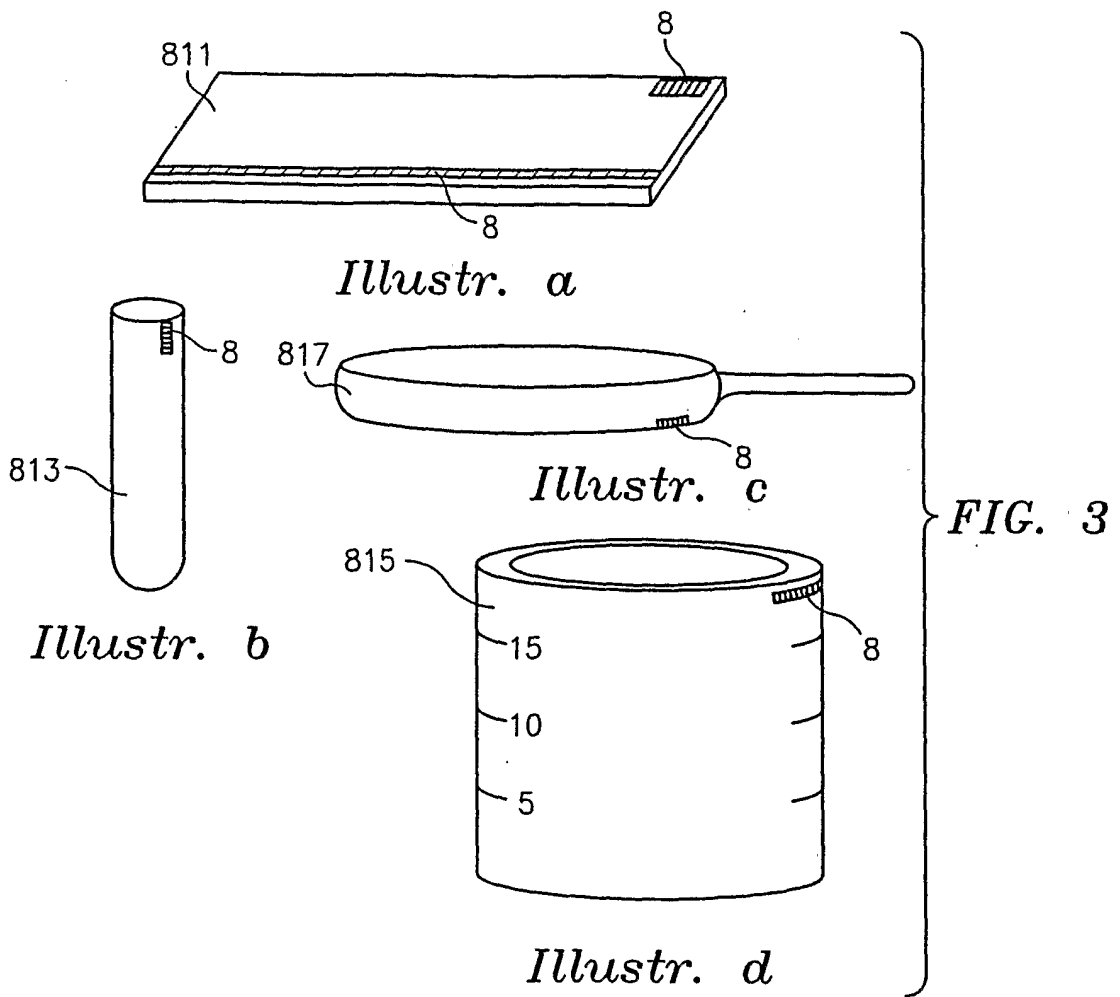

FIG. 4

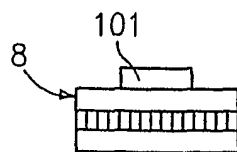
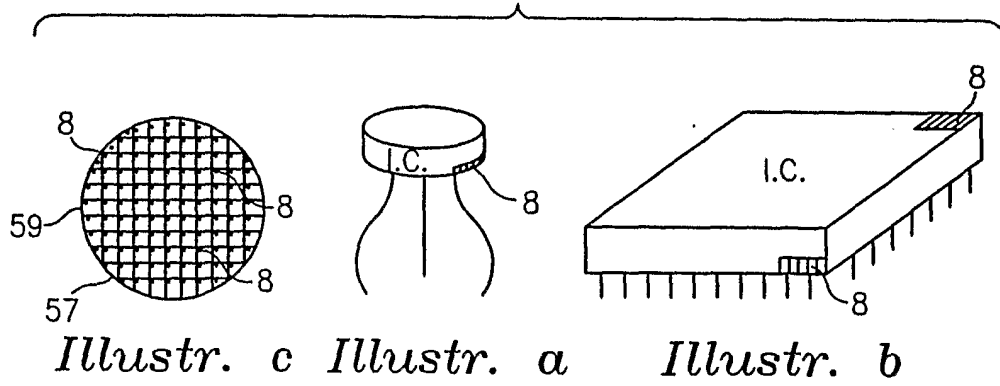

FIG. 5

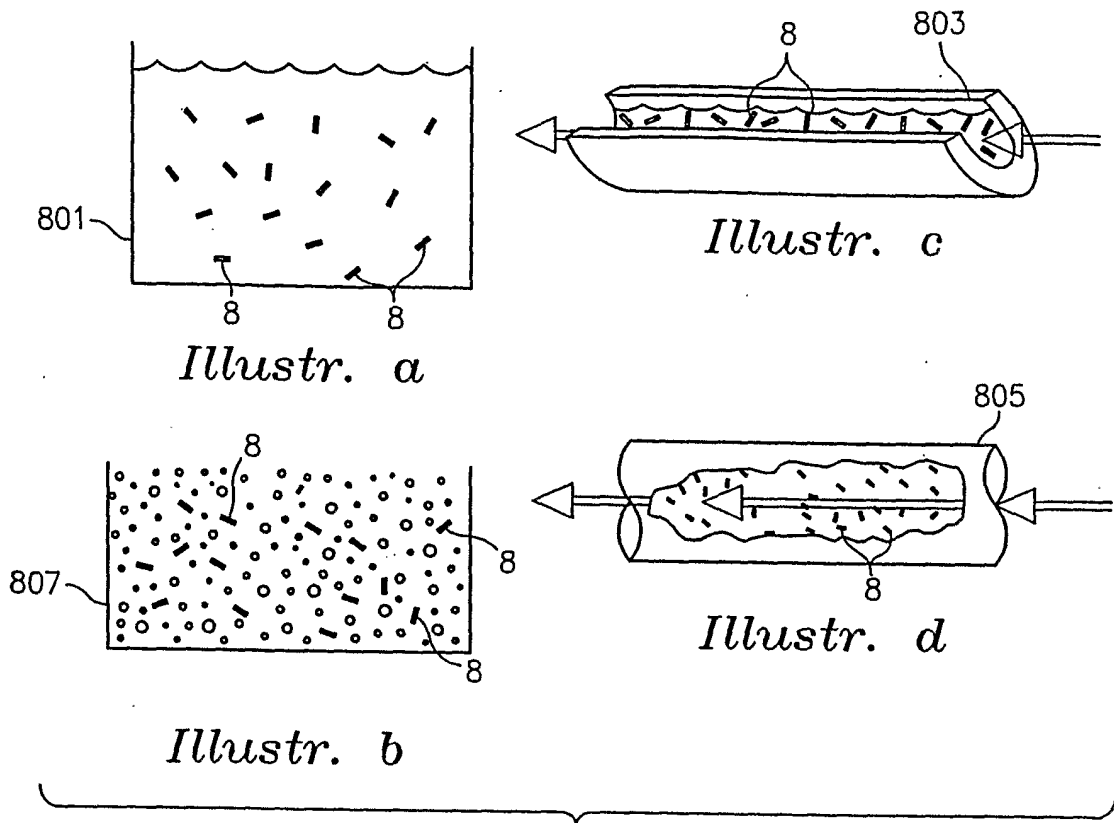

FIG. 6

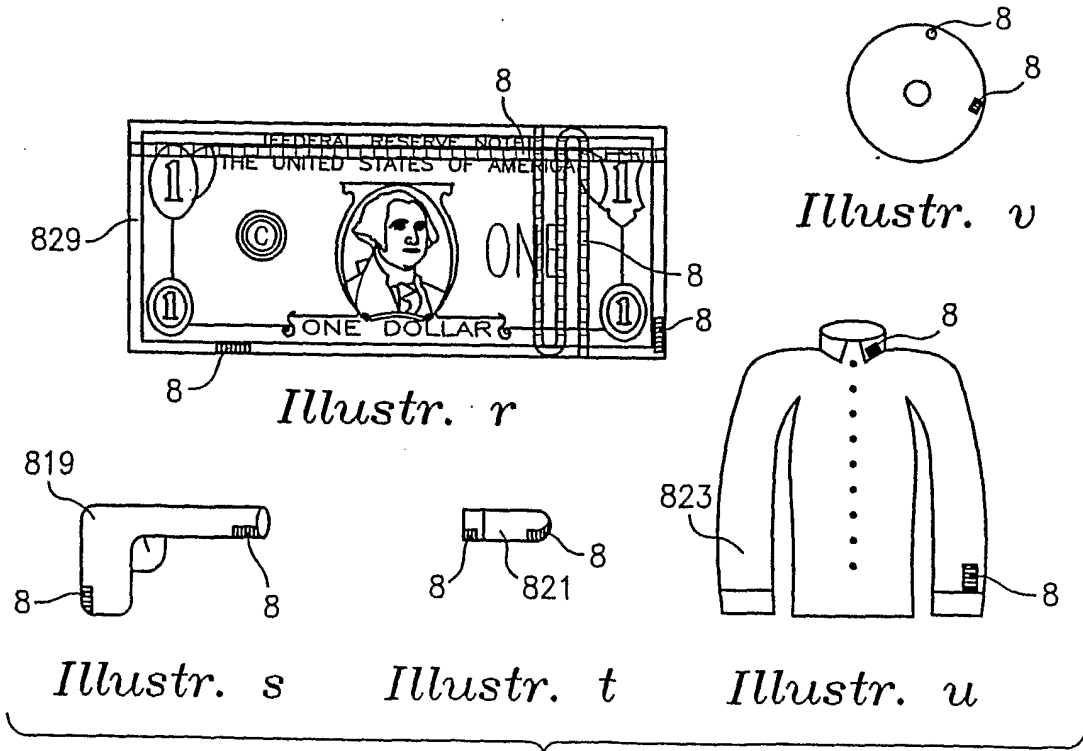
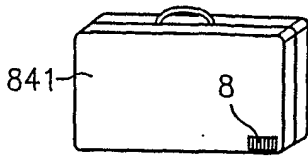
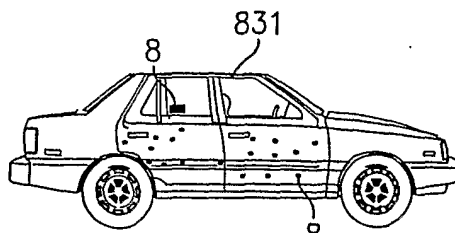

FIG. 7 (cont)



Illustr. a



Illustr. b

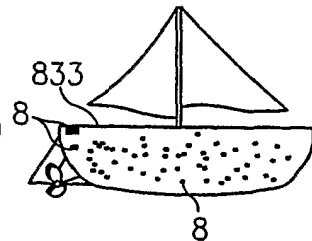

Illustr. c

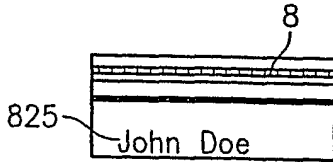

Illustr. d

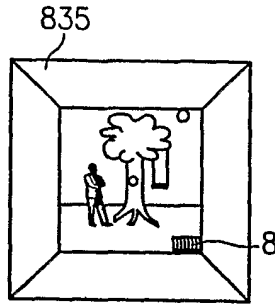

Illustr. f

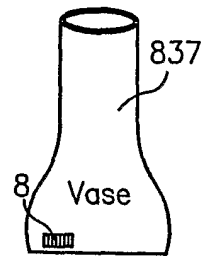

Illustr. g

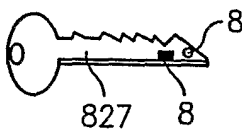

Illustr. e

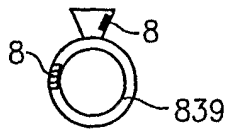

Illustr. h

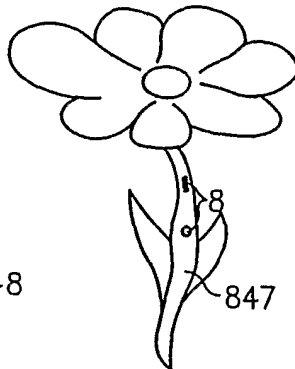

Illustr. k

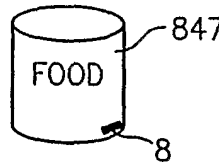

Illustr. i

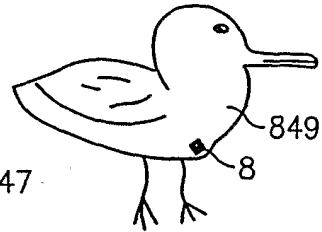

Illustr. m

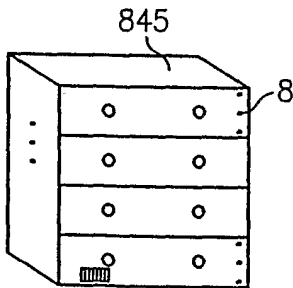

Illustr. j

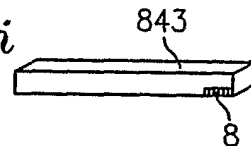

Illustr. l

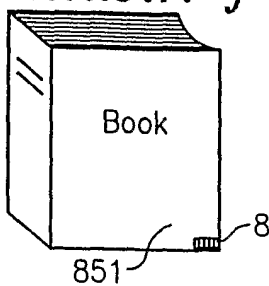

Illustr. n

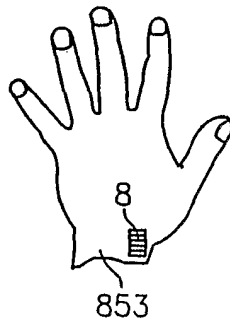

Illustr. o

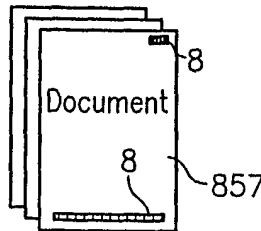

Illustr. q



Illustr. p



FIG. 7

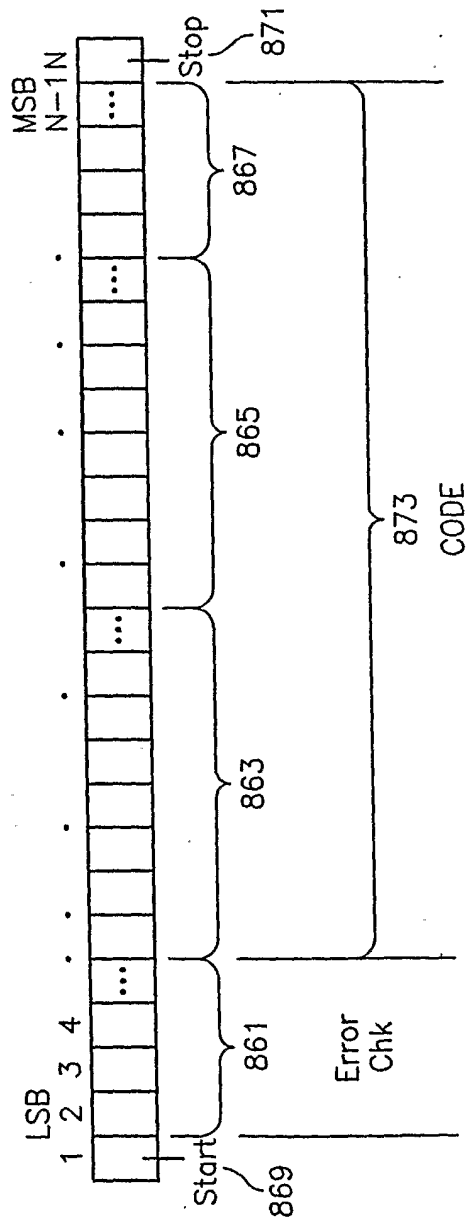

FIG. 8

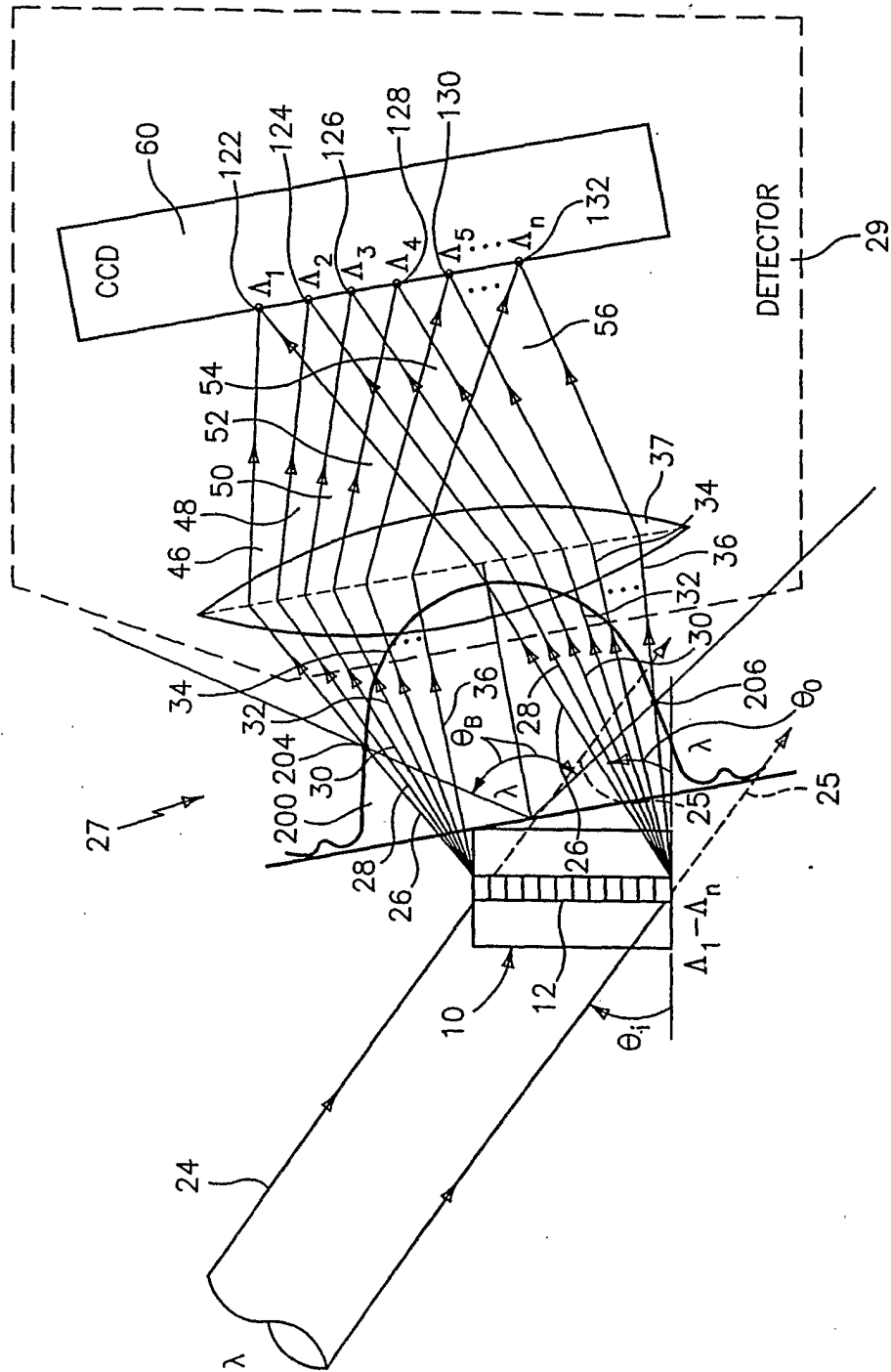

FIG. 9

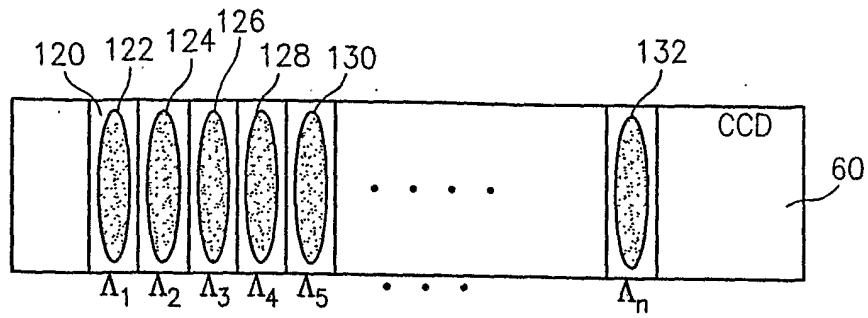

FIG. 10

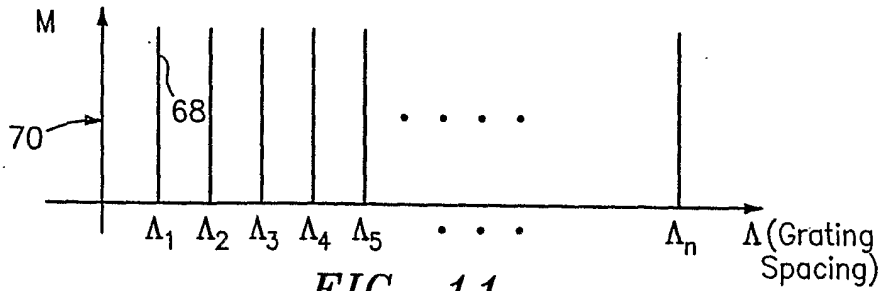

FIG. 11

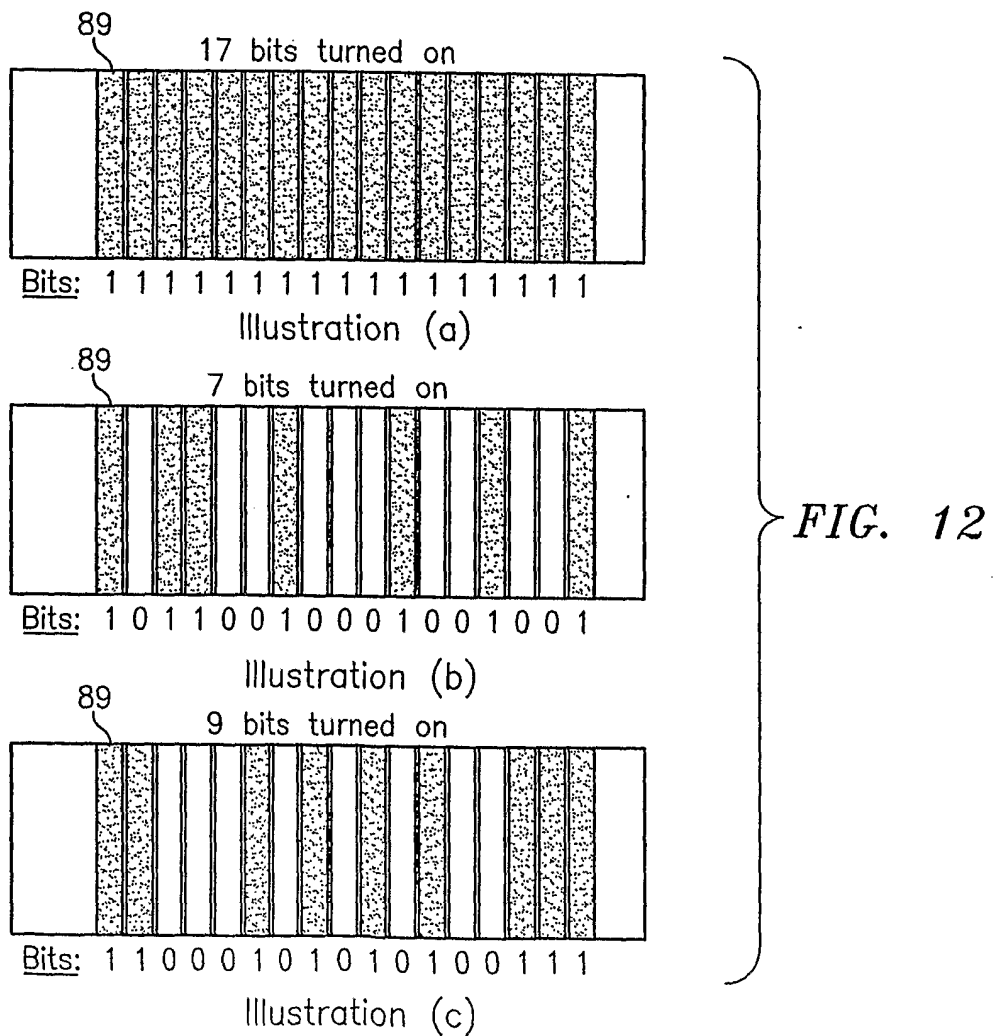

FIG. 12

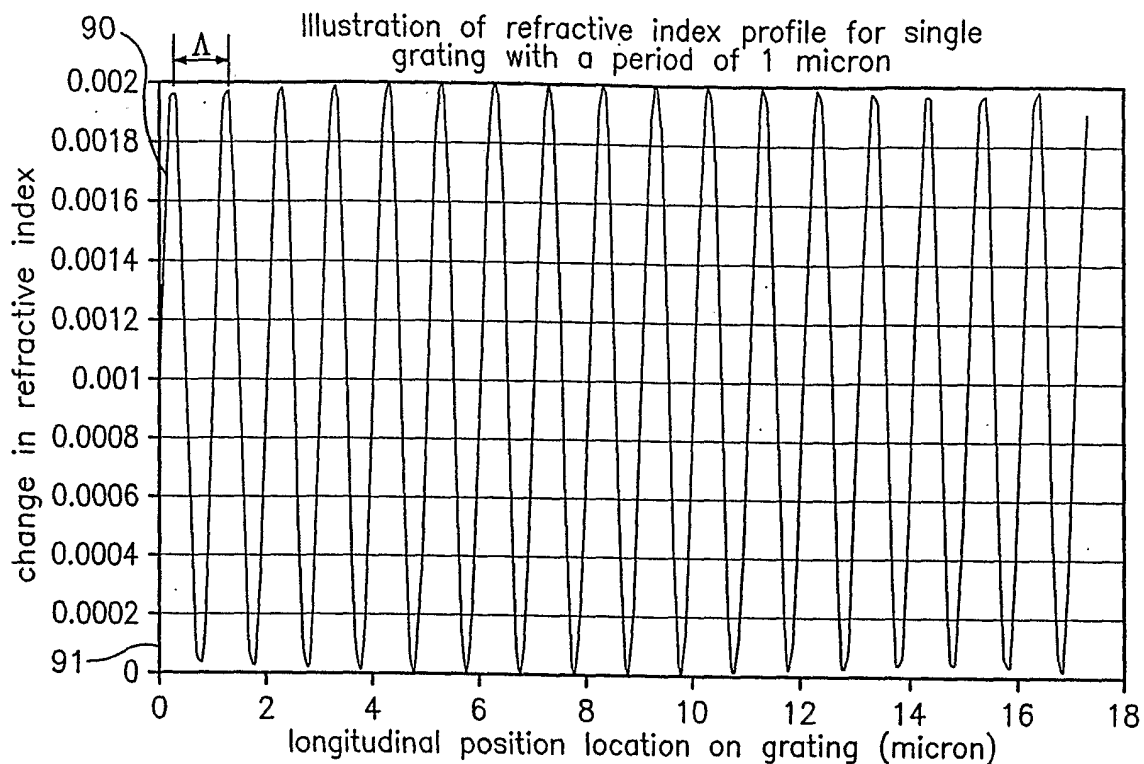

Illustration (a)

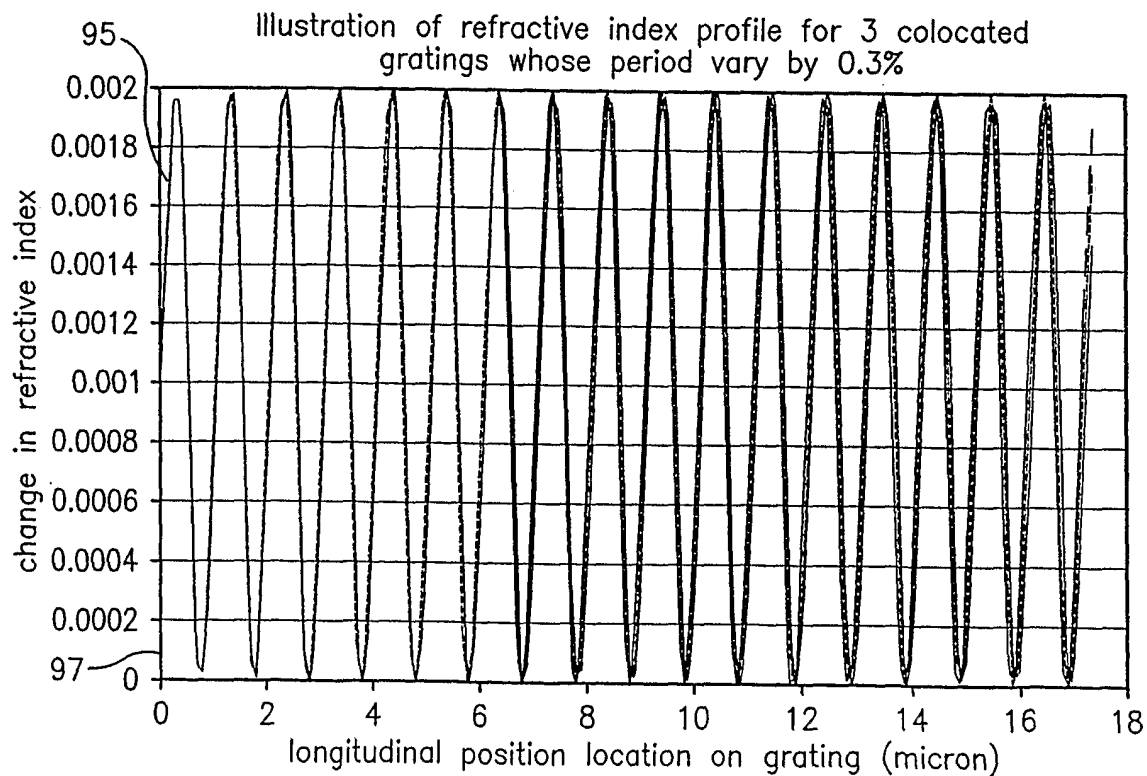

FIG. 13

--- grating 1 grating 2 — grating 3

Illustration (c)

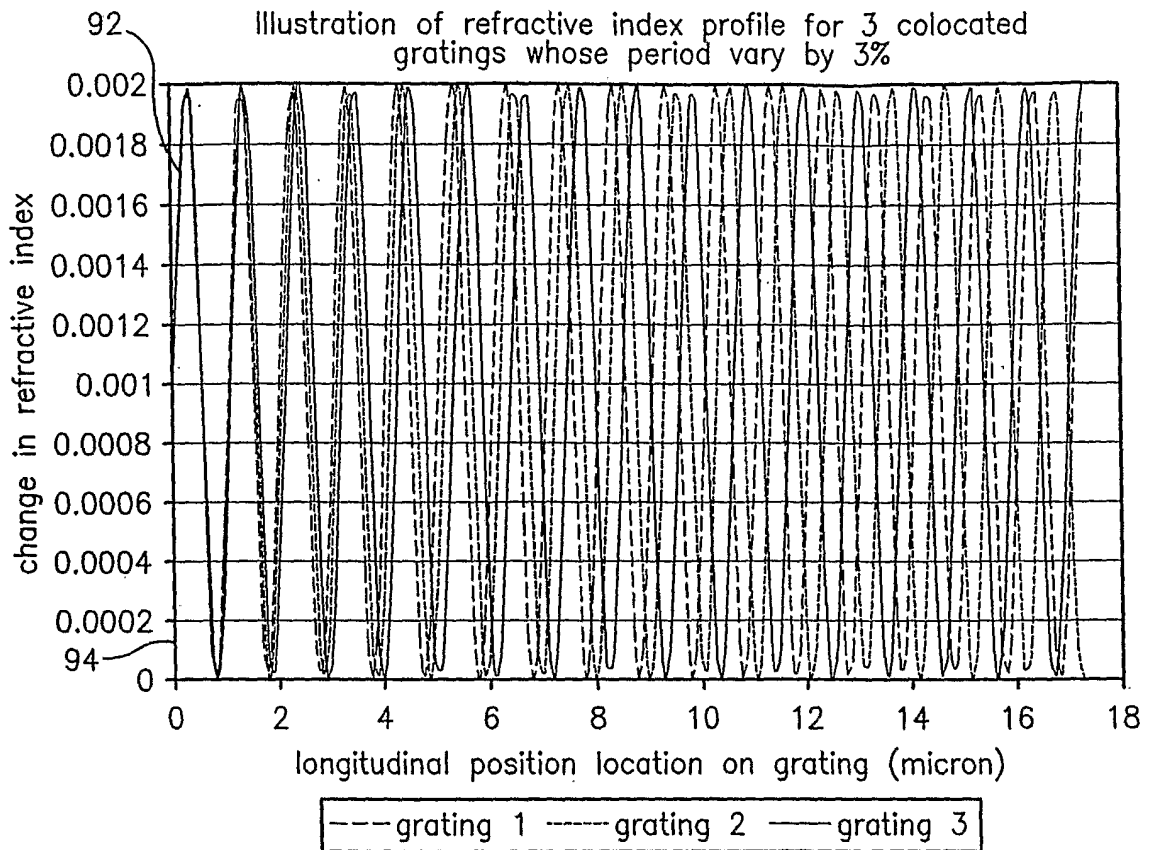

Illustration (b)

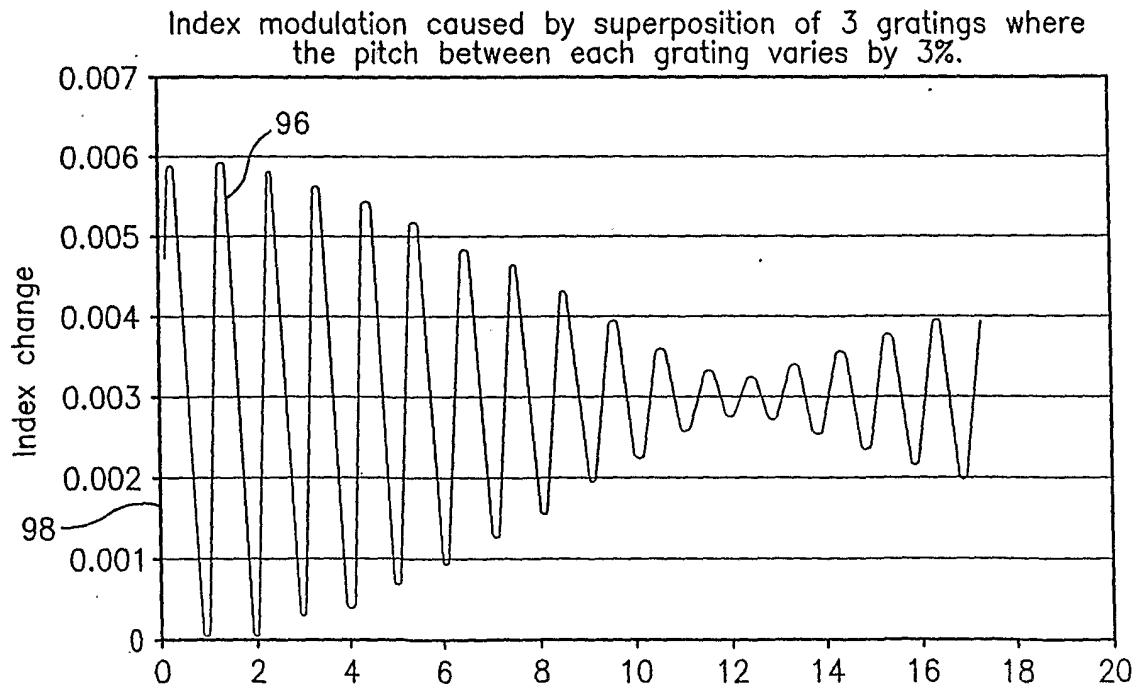

Illustration (d)

FIG. 13

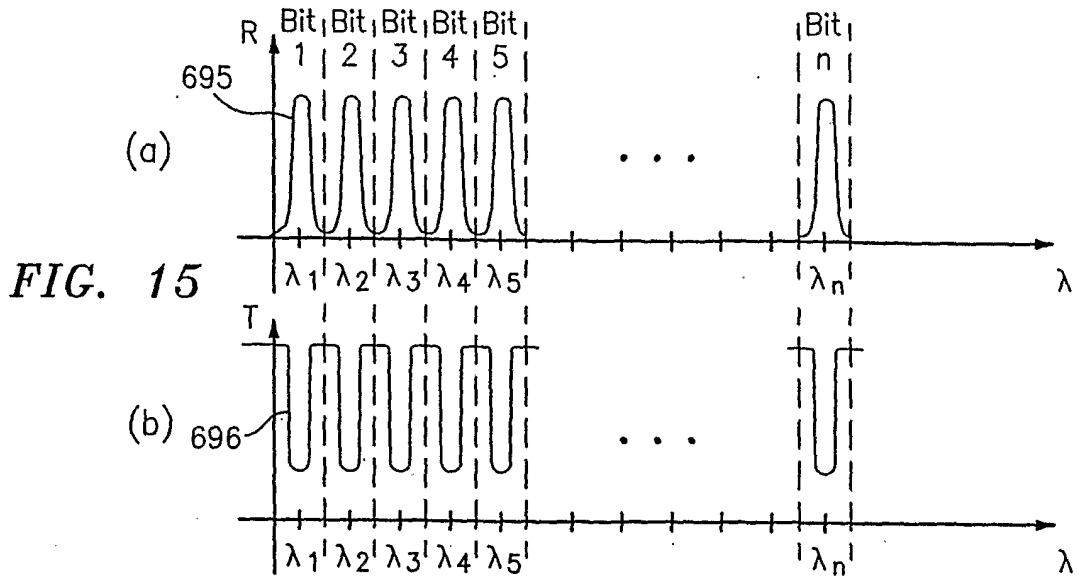

FIG. 15

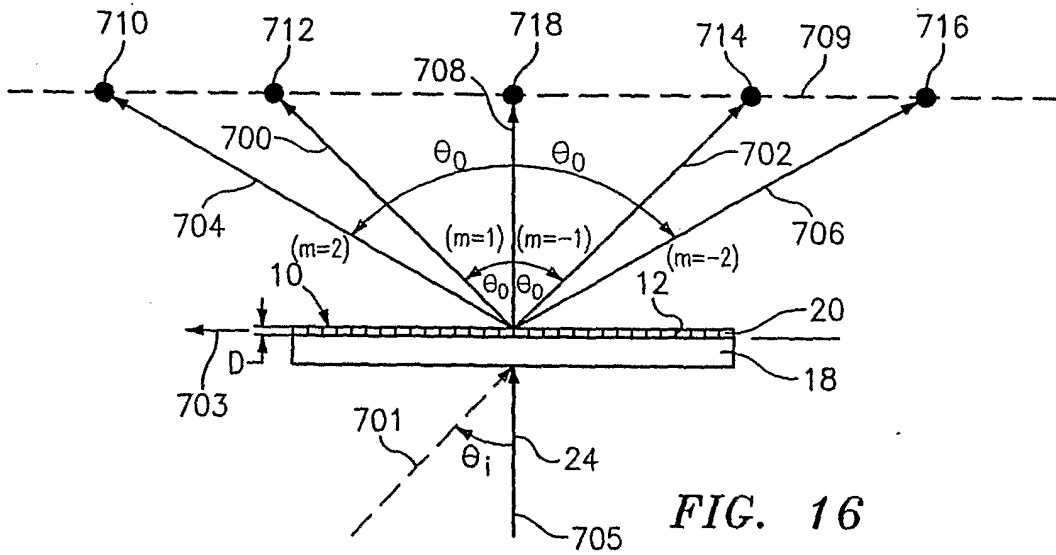

FIG. 16

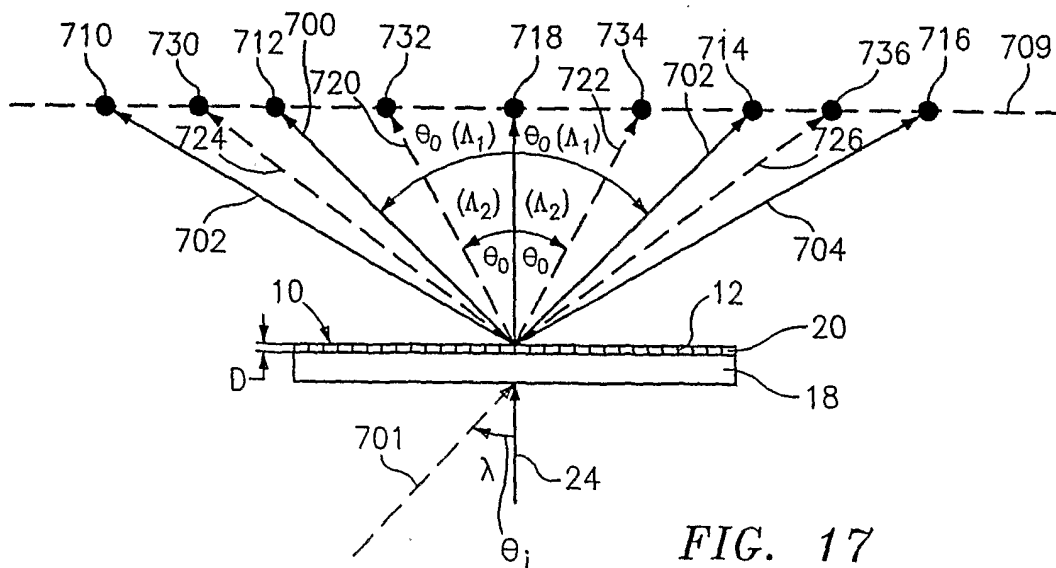

FIG. 17

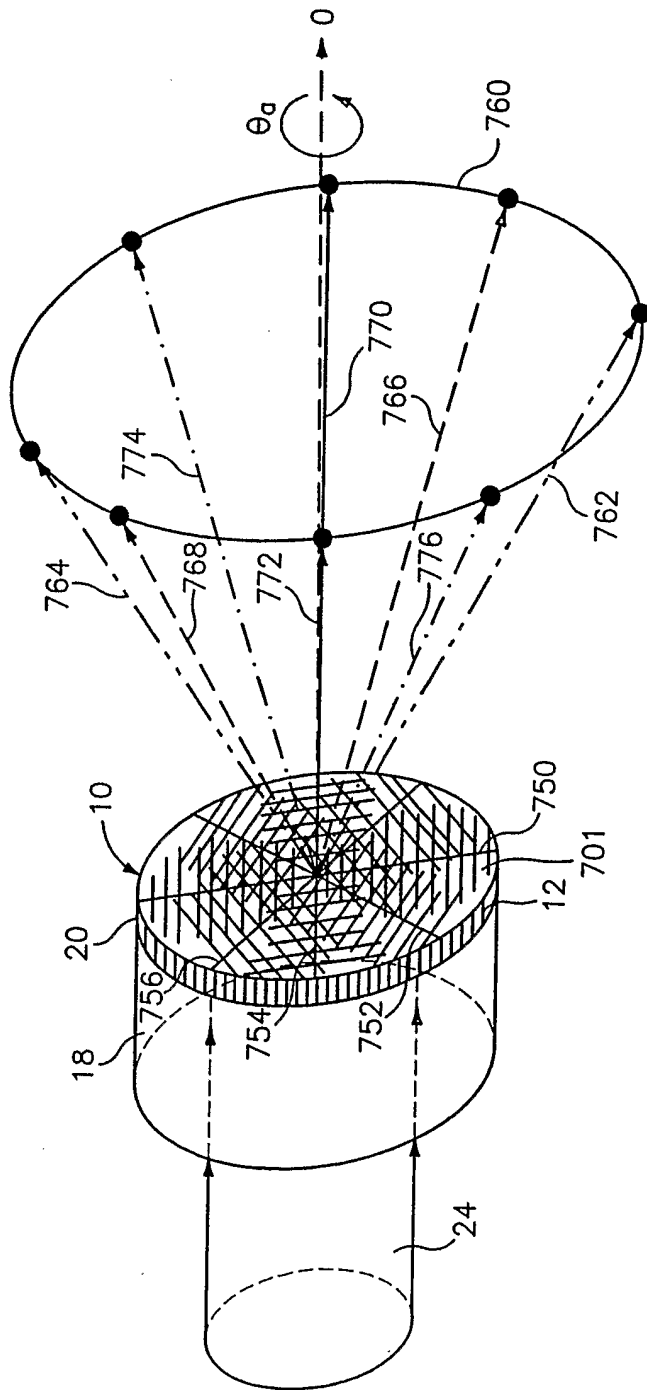

FIG. 18

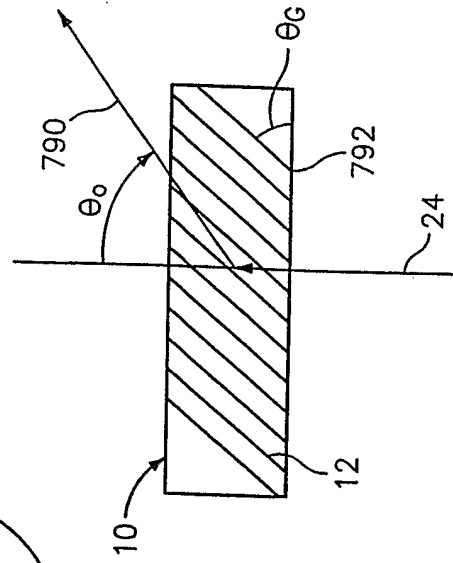

FIG. 19

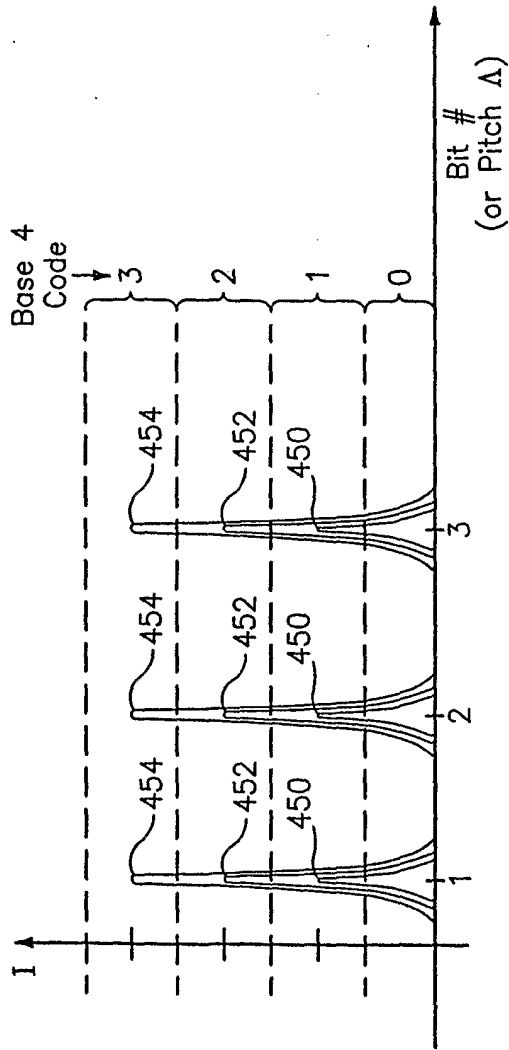

FIG. 20

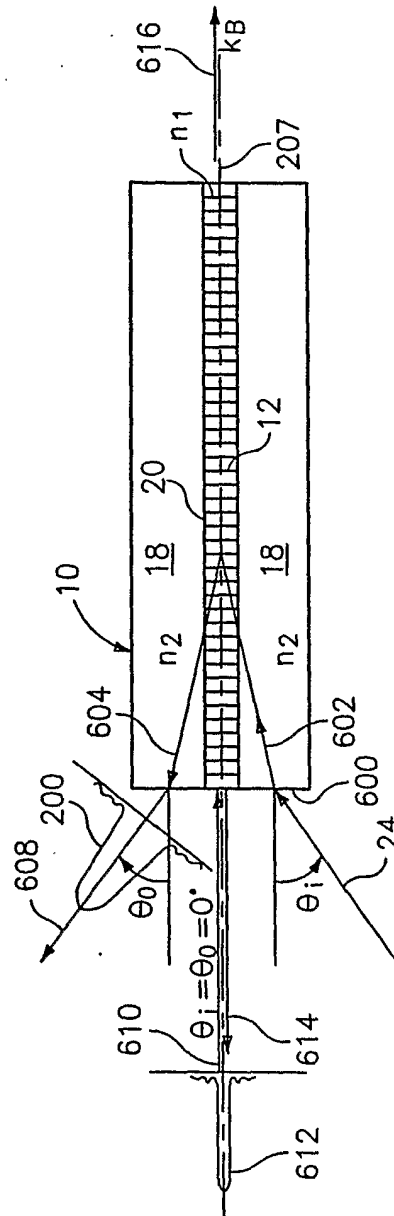

FIG. 21

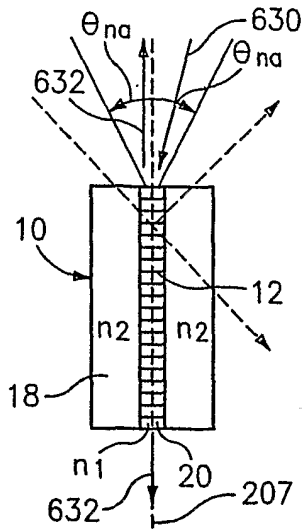

FIG. 22

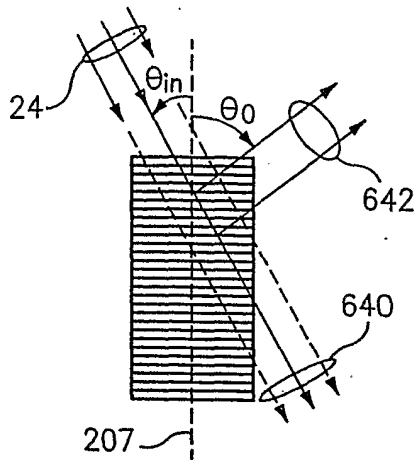
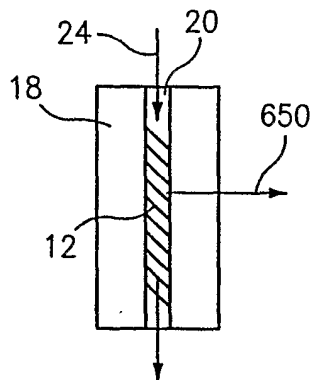
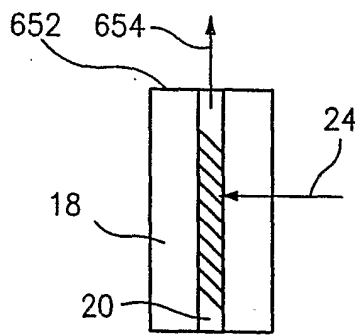

FIG. 23



Illustration(a)



Illustration(b)

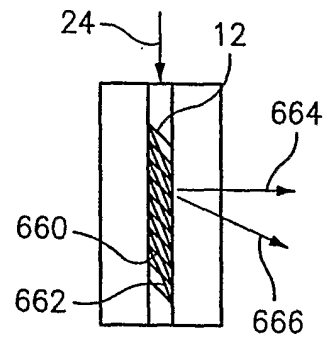

Illustration(c)

FIG. 24

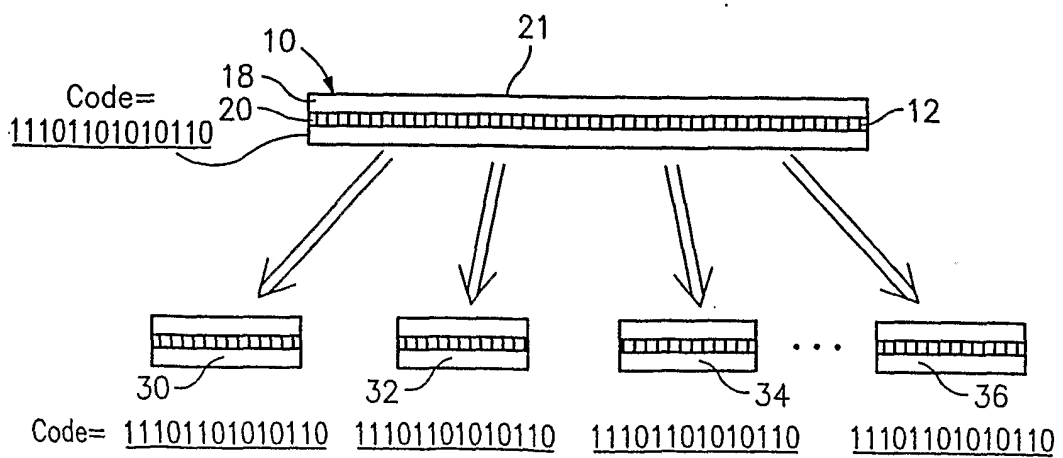

FIG. 26

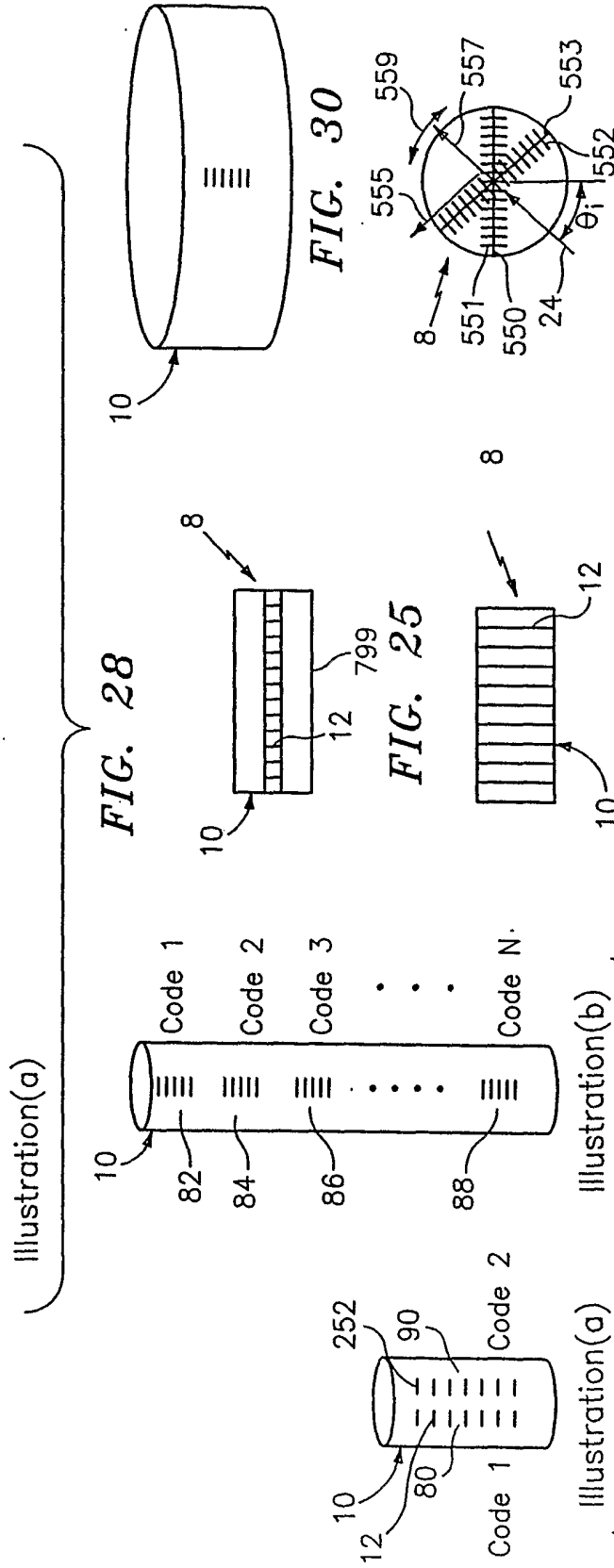
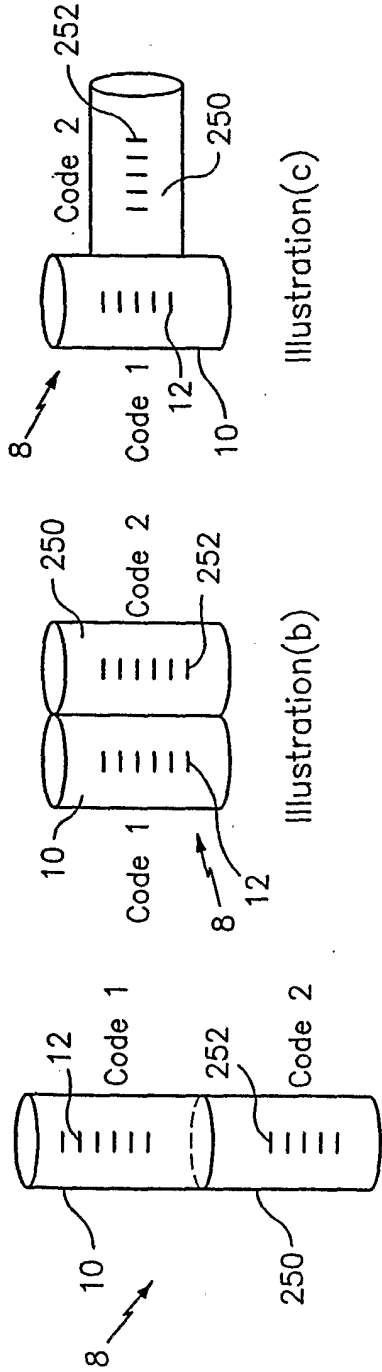

FIG. 31

FIG. 27

FIG. 25

FIG. 30

FIG. 28

FIG. 29

Illustration(b)

Illustration(a)

Illustration(a)

Illustration(b)

Illustration(c)

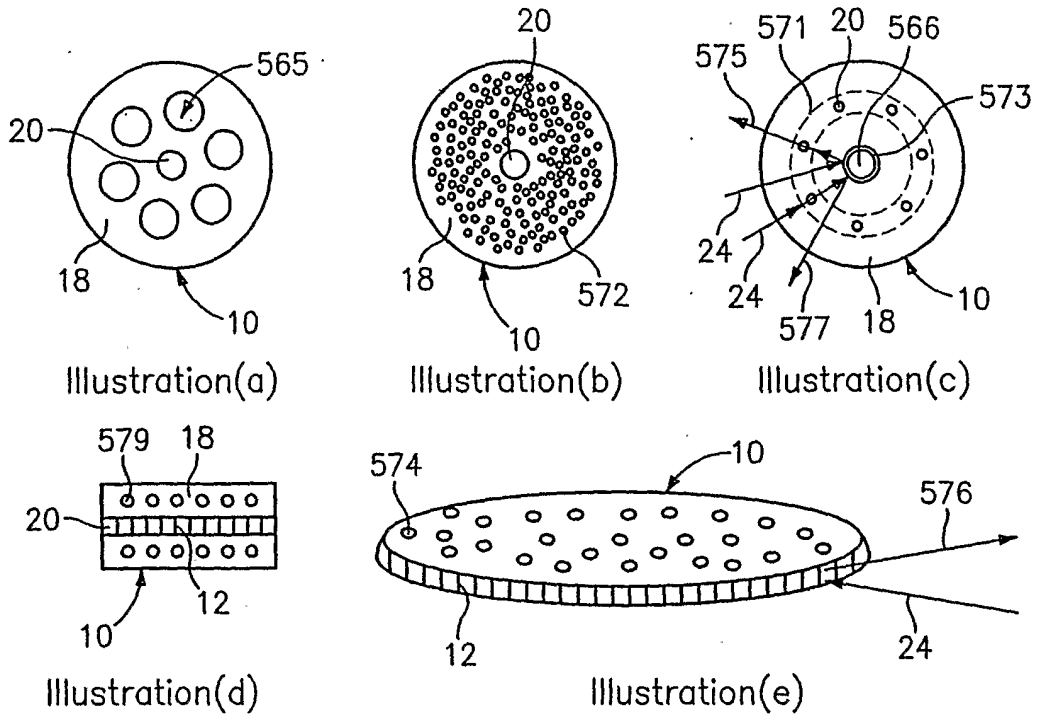

FIG. 32

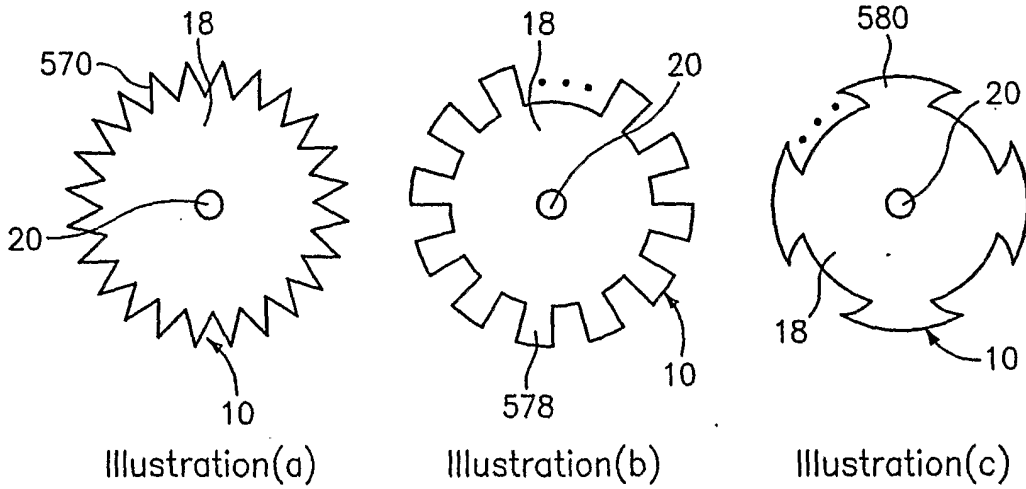

FIG. 33

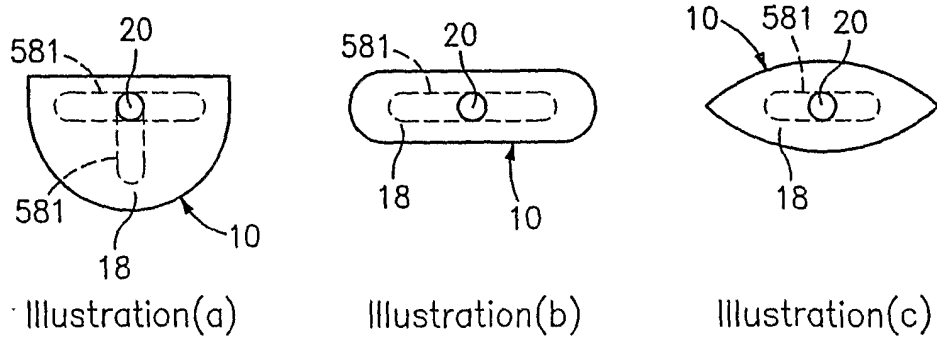

FIG. 34