



INTERNATIONAL APPLICATION PUBLISHED UNDER THE PATENT COOPERATION TREATY (PCT)

<p>(51) International Patent Classification <sup>6</sup> : <b>H01Q 1/24</b></p>	<p><b>A1</b></p>	<p>(11) International Publication Number: <b>WO 99/03167</b> (43) International Publication Date: 21 January 1999 (21.01.99)</p>
<p>(21) International Application Number: PCT/SE98/01272 (22) International Filing Date: 26 June 1998 (26.06.98) (30) Priority Data: 9702660-3 9 July 1997 (09.07.97) SE (71) Applicant (for all designated States except US): ALLGON AB [SE/SE]; P.O. Box 500, S-184 25 Åkersberga (SE). (72) Inventor; and (75) Inventor/Applicant (for US only): FILIPSSON, Karl, Gunnar [SE/SE]; Tuvkatan 39, S-589 57 Linköping (SE). (74) Agents: MODIN, Jan et al.; Axel Ehmers Patentbyrå AB, P.O. Box 10316, S-100 55 Stockholm (SE).</p>		<p>(81) Designated States: AL, AM, AT, AT (Utility model), AU, AZ, BA, BB, BG, BR, BY, CA, CH, CN, CU, CZ, CZ (Utility model), DE, DE (Utility model), DK, DK (Utility model), EE, EE (Utility model), ES, FI, FI (Utility model), GB, GE, GH, GM, GW, HU, ID, IL, IS, JP, KE, KG, KP, KR, KZ, LC, LK, LR, LS, LT, LU, LV, MD, MG, MK, MN, MW, MX, NO, NZ, PL, PT, RO, RU, SD, SE, SG, SI, SK, SK (Utility model), SL, TJ, TM, TR, TT, UA, UG, US, UZ, VN, YU, ZW, ARIPO patent (GH, GM, KE, LS, MW, SD, SZ, UG, ZW), Eurasian patent (AM, AZ, BY, KG, KZ, MD, RU, TJ, TM), European patent (AT, BE, CH, CY, DE, DK, ES, FI, FR, GB, GR, IE, IT, LU, MC, NL, PT, SE), OAPI patent (BF, BJ, CF, CG, CI, CM, GA, GN, ML, MR, NE, SN, TD, TG).</p> <p><b>Published</b> <i>With international search report.</i></p>

(54) Title: HAND-PORTABLE TELEPHONE WITH RADIATION ABSORBING DEVICE

(57) Abstract

A hand-portable telephone including a casing (1), an antenna device (7) with at least one radiating element (7a, 7b) located in said casing, and a protective device for absorbing a substantial part of the electromagnetic energy being radiated towards the user's head or some other body portion. The device comprises an electrically resistive layer (9) having a surface resistance of at least 25Ω/square.

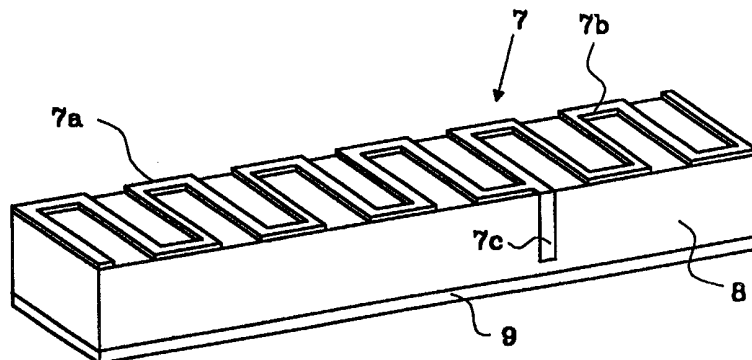
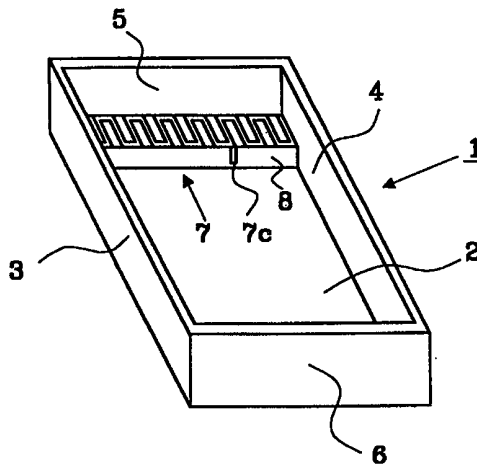

**FOR THE PURPOSES OF INFORMATION ONLY**

Codes used to identify States party to the PCT on the front pages of pamphlets publishing international applications under the PCT.

AL	Albania	ES	Spain	LS	Lesotho	SI	Slovenia
AM	Armenia	FI	Finland	LT	Lithuania	SK	Slovakia
AT	Austria	FR	France	LU	Luxembourg	SN	Senegal
AU	Australia	GA	Gabon	LV	Latvia	SZ	Swaziland
AZ	Azerbaijan	GB	United Kingdom	MC	Monaco	TD	Chad
BA	Bosnia and Herzegovina	GE	Georgia	MD	Republic of Moldova	TG	Togo
BB	Barbados	GH	Ghana	MG	Madagascar	TJ	Tajikistan
BE	Belgium	GN	Guinea	MK	The former Yugoslav Republic of Macedonia	TM	Turkmenistan
BF	Burkina Faso	GR	Greece	ML	Mali	TR	Turkey
BG	Bulgaria	HU	Hungary	MN	Mongolia	TT	Trinidad and Tobago
BJ	Benin	IE	Ireland	MR	Mauritania	UA	Ukraine
BR	Brazil	IL	Israel	MW	Malawi	UG	Uganda
BY	Belarus	IS	Iceland	MX	Mexico	US	United States of America
CA	Canada	IT	Italy	NE	Niger	UZ	Uzbekistan
CF	Central African Republic	JP	Japan	NL	Netherlands	VN	Viet Nam
CG	Congo	KE	Kenya	NO	Norway	YU	Yugoslavia
CH	Switzerland	KG	Kyrgyzstan	NZ	New Zealand	ZW	Zimbabwe
CI	Côte d'Ivoire	KP	Democratic People's Republic of Korea	PL	Poland		
CM	Cameroon	KR	Republic of Korea	PT	Portugal		
CN	China	KZ	Kazakstan	RO	Romania		
CU	Cuba	LC	Saint Lucia	RU	Russian Federation		
CZ	Czech Republic	LI	Liechtenstein	SD	Sudan		
DE	Germany	LK	Sri Lanka	SE	Sweden		
DK	Denmark	LR	Liberia	SG	Singapore		
EE	Estonia						

## HAND-PORTABLE TELEPHONE WITH RADIATION ABSORBING DEVICE

The present invention relates to a hand-portable telephone, including a casing, an antenna device with at least one radiating element, and a protective device for absorbing a  
5 substantial part of the electromagnetic energy being radiated from said at least one radiating element towards a human body portion during use of the telephone.

10 Such protective devices are generally known. Normally, the protective devices are disposed in the vicinity of an antenna rod being extendable from the telephone casing. In the US patent specification 5335366, however, a protective device is disclosed, which comprises a shielding means located inside the  
15 casing so as to reflect and/or absorb any electromagnetic radiation generated by the components inside the telephone casing.

The reflecting material is said to be aluminium, other metal, polymer or other suitable material, whereas the absorbing  
20 material is said to be lead or some other suitable material. It is mentioned that a material such as lead will present a relatively dense block to the passage of electromagnetic radiation.

However, although lead will effectively absorb electromagnetic  
25 radiation having very high energy, such as X-rays or  $\gamma$ -rays, lead and similar metal materials will not readily absorb microwaves. The reflective capacity of such devices as disclosed in the US patent specification 5 335 366 mentioned above is also questionable, due to the small dimensions of the  
30 reflector structures in relation to the wavelength of the microwave radiation. Therefore, the radiation pattern and intensity will not be significantly altered by these prior art devices. Rather, it is likely that a major part of the radiation directed towards the head of the user will pass  
35 around the shielding device.

The main object of the present invention is to provide a hand-portable telephone with a more effective protective device, which will absorb a significant part of the microwave energy being radiated towards the head or some other body portion of the user of the telephone.

Other objects are to provide a protective device which is simple, lightweight and inexpensive. Furthermore, the protective device should be easy to install in the telephone, and it should be reliable even after long use.

The main object stated above is achieved by a protective device comprising an electrically resistive layer, which is disposed at a distance from the radiating element adjacent to a part of the casing being designed to be held adjacent to the human body portion, said electrically resistive layer having a surface resistance of at least  $25\Omega/\text{square}$ .

As opposed to most of the previously known protective devices, the present invention does not provide a metallic, electrically conductive material serving as a reflector or shielding device. Rather, the inventive concept is to absorb a significant part of the radiation being directed towards the particular human body portion and to transfer the radiation into heat. In hand-portable telephones, the power fed into the radiating element is moderate, and the generated heat will therefore be kept at a relatively low level.

Preferably, the surface resistance of the resistive layer should be  $25\text{--}800\Omega/\text{square}$ , in particular  $150\text{--}250\Omega/\text{square}$ .

Ordinary metal materials have a much lower resistance. However, because of the small skin depth of microwaves into a metal material, the desired surface resistance can be obtained for

very thin metal films having a thickness in the order of 10-100nm, i.e. less than 1 $\mu$ m. Such very thin metal films are commercially available, normally in the form of a metal film deposited on a plastic substrate, e.g. from the Advanced Deposition  
5 Technologies, Taunton, Massachusetts, USA.

As an alternative to such a thin metal film, it is possible to use an electrically conducting polymer material, such as polypyrrole. Such materials are also commercially available,  
10 e.g. under the registered trademark CONTEX from Milliken & Co.

The electrically resistive layer may be disposed on a support structure mounted inside the casing or it may be disposed on at least one wall defining the casing.  
15

These and other features are stated in the dependent claims and will be apparent from the detailed description below.

The invention will be described more fully below with reference  
20 to the appended drawings illustrating a preferred embodiment.

Fig. 1 illustrates schematically, in a perspective view, a cellular telephone casing with an antenna device mounted on a support structure, the rear part of the casing being taken away  
25 for clarity;

Fig. 2 shows, likewise in a perspective view, the antenna device and a support structure; and

30 Fig. 3 illustrates, to a larger scale, the antenna device and its support structure with a protective device according to the invention.

In the drawings, only those parts of the hand-portable cellular  
35 telephone are shown, which are essential for understanding the

basic features of the present invention. The rear part and the electronic circuitry inside the casing have been left out in fig. 1.

5 The casing 1 of the telephone is generally elongated and box-like with a rectangular front wall 2, side walls 3 and 4 and end walls 5 and 6. At the upper end portion of the casing, adjacent to the end wall 5, there is an antenna device 7 mounted on a transverse support bar 8 and including two meander-  
10 configured radiating elements 7a and 7b, connected to a common feed point 7c. See also fig. 3. The antenna device is preferably of the kind disclosed in the co-pending patent application entitled "Compact antenna device" filed on the same day by the same applicant. The contents of said co-pending application  
15 is incorporated herein by reference.

As is generally known, the meander elements 7a, 7b, when being fed by microwave energy, will emit electromagnetic microwave radiation in virtually all directions. Thus, the cellular  
20 telephone can communicate by way of microwave signals to and from a base station irrespective of the orientation of the telephone casing. However, it is inevitable that a substantial portion of the radiated microwave energy will propagate through the front wall 2 and into the head of the person using the  
25 telephone.

According to the present invention, a significant part of this radiated energy will be absorbed by an electrically resistive layer 9 (fig. 3) which is disposed at a distance from the  
30 radiating element 7 adjacent to the front wall 2 of the casing being designed to be held adjacent to the head of the user. In this embodiment, the resistive layer consists of an extremely thin aluminium film deposited on a plastic substrate, the thickness of the aluminium film being only about 10nm. Such  
35 materials are commercially available. Generally, the surface

resistance of the layer 9 should be at least  $25\Omega/\text{square}$ , and not exceeding  $800\ \Omega/\text{square}$ , preferably between 150 and  $250\Omega/\text{square}$ .

5 The supporting bar 8 may be constituted by a hollow thermoplastic material or a foam material, such as Rohacell.

In the embodiment represented by figs. 1 and 3, the electrically resistive layer will be confined only to the relatively  
10 small area underneath the antenna device 7. Normally, such a limited extension of the resistive layer is sufficient to obtain the desired result of absorbing a major portion of the microwave radiation directed towards a user's head. However, it is of course possible to extend the resistive layer to the  
15 total area of the bottom wall 2, or only a part thereof, where radiation is dominant. One possibility is to apply the layer onto a printed circuit card 10 carrying the support bar 8 and the antenna device 7 and dimensioned to be fitted into the casing 2, as shown in fig. 2.

20

As indicated above, it is possible to use an electrically conducting polymer material, such as polypyrrole, instead of the thin metal film, provided that the surface resistance falls within the interval  $25\text{-}800\Omega/\text{square}$ .

25

Any other material having such a surface resistance can of course also be used within the scope of the present invention.

Naturally, the electrically resistive layer can also be disposed  
30 directly onto one or more of the walls of the casing, e.g. on the inside, the outside or as an integrated part of the wall. Moreover, the layer may comprise two or more sub-layers provided that the combined surface resistance is at least  $25\Omega/\text{square}$  so as to effectively convert a significant part of  
35 the impinging radiation into heat.

## CLAIMS

1. A hand-portable telephone, including a casing (1), an  
5 antenna device (7) with at least one radiating element (7a,  
7b), and a protective device (9) for absorbing a substantial  
part of the electromagnetic energy being radiated from said at  
least one radiating element towards a human body portion during  
use of the telephone, c h a r a c t e r i z e d i n t h a t  
10 said protective device comprises an electrically resistive  
layer (9), which is disposed at a distance from said radiating  
element (7a, 7b) adjacent to a part of said casing (1) being  
designed to be held adjacent to said human body portion, said  
electrically resistive layer having a surface resistance of at  
15 least  $25\Omega$ /square.
2. A telephone as defined in claim 1, wherein said electri-  
cally resistive layer (9) has a surface resistance of 25 to  
800 $\Omega$ /square.  
20
3. A telephone as defined in claim 2, wherein said electri-  
cally resistive layer (9) has a surface resistance of 150 to  
250 $\Omega$ /square.
- 25 4. A telephone as defined in any one of claims 1 to 3,  
wherein said electrically resistive layer (9) comprises a thin  
metal film.
5. A telephone as defined in claim 4, wherein said thin  
30 metal film is deposited on a plastic substrate.
6. A telephone as defined in claim 4 or 5, wherein said thin  
metal film has a thickness of 10-100 nm.



7. A telephone as defined in any one of claims 4 to 6, wherein said metal film consists substantially of aluminium.

5 8. A telephone as defined in any one of claims 4 to 6, wherein said metal film consists substantially of zink.

9. A telephone as defined in any one of claims 1 to 3, wherein said resistive layer comprises an electrically conductive polymer material.

10

10. A telephone as defined in claim 9, wherein said polymer material is polypyrrole.

15

11. A telephone as defined in any one of claims 1 to 10, wherein said electrically resistive layer is disposed on a support structure (8; 10) mounted inside said casing (1).

20

12. A telephone as defined in any one of claims 1 to 10, wherein said electrically resistive layer is disposed on the inside of at least one wall defining said casing.

25

13. A telephone as defined in any one of claims 1 to 10, wherein said electrically resistive layer is integrated with at least one wall defining said casing.

30

14. A telephone as defined in any one of claims 1 to 10, wherein said electrically resistive layer is disposed on the outside of at least one wall defining said casing.

15. A telephone as defined in any one of the preceding claims, wherein said at least one radiating element (7a, 7b) is located in said casing.

35

16. A telephone as defined in any one of the preceding claims, wherein said electrically resistive layer comprises at

least two sub-layers, the combined surface resistance being at least  $25\Omega/\text{square}$ .

1/1

Fig. 1

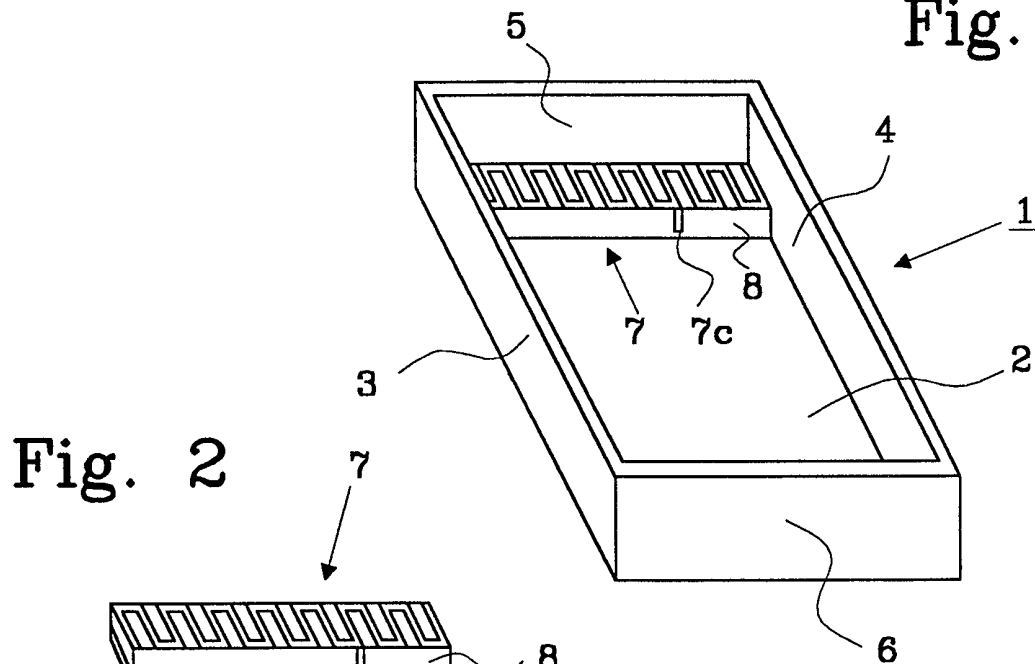

Fig. 2

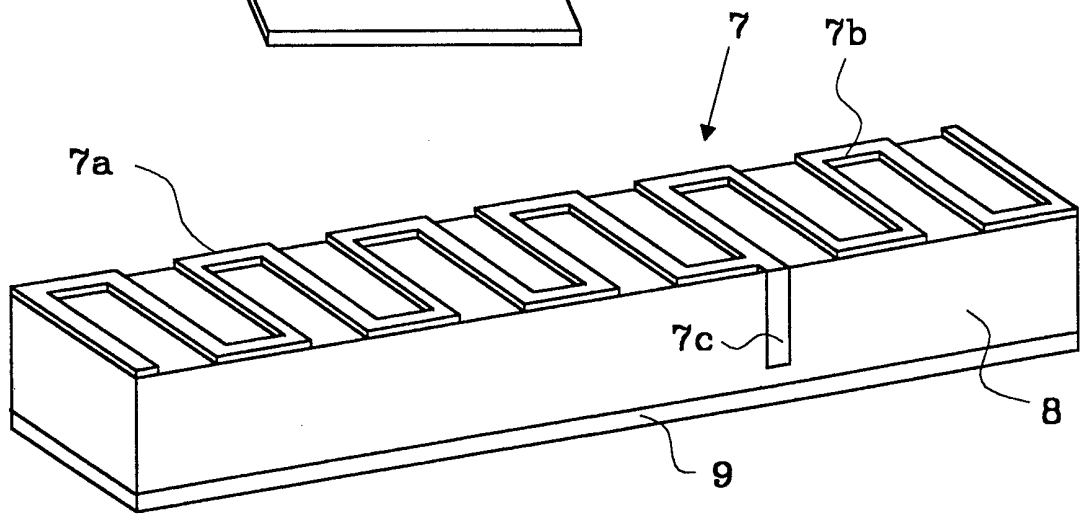
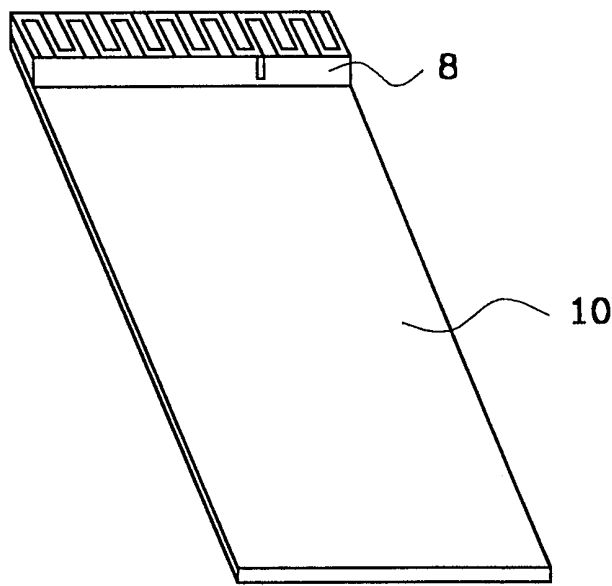

Fig. 3

## INTERNATIONAL SEARCH REPORT

International application No.

PCT/SE 98/01272

## A. CLASSIFICATION OF SUBJECT MATTER

IPC6: H01Q 1/24

According to International Patent Classification (IPC) or to both national classification and IPC

## B. FIELDS SEARCHED

Minimum documentation searched (classification system followed by classification symbols)

IPC6: H01Q

Documentation searched other than minimum documentation to the extent that such documents are included in the fields searched

SE,DK,FI,NO classes as above

Electronic data base consulted during the international search (name of data base and, where practicable, search terms used)

## C. DOCUMENTS CONSIDERED TO BE RELEVANT

Category*	Citation of document, with indication, where appropriate, of the relevant passages	Relevant to claim No.
A	EP 0588271 A1 (ALCATEL ITALIA S.P.A.), 23 March 1994 (23.03.94), see the whole document  --	1-16
A	DE 1960041 (CHRETIN JEAN), 19 November 1970 (19.11.70), see the whole document  --	1-16
A	US 5335366 A (JOHN J. DANIELS), 2 August 1994 (02.08.94), cited in the application  -- -----	1-16

 Further documents are listed in the continuation of Box C. See patent family annex.

\* Special categories of cited documents:

"A" document defining the general state of the art which is not considered to be of particular relevance

"E" earlier document but published on or after the international filing date

"L" document which may throw doubts on priority claim(s) or which is cited to establish the publication date of another citation or other special reason (as specified)

"O" document referring to an oral disclosure, use, exhibition or other means

"P" document published prior to the international filing date but later than the priority date claimed

"T" later document published after the international filing date or priority date and not in conflict with the application but cited to understand the principle or theory underlying the invention

"X" document of particular relevance: the claimed invention cannot be considered novel or cannot be considered to involve an inventive step when the document is taken alone

"Y" document of particular relevance: the claimed invention cannot be considered to involve an inventive step when the document is combined with one or more other such documents, such combination being obvious to a person skilled in the art

"&amp;" document member of the same patent family

Date of the actual completion of the international search

27 October 1998

Date of mailing of the international search report

31 -10- 1998

Name and mailing address of the ISA/

Swedish Patent Office

Box 5055, S-102 42 STOCKHOLM

Facsimile No. +46 8 666 02 86

Authorized officer

Rune Bengtsson

Telephone No. +46 8 782 25 00

## INTERNATIONAL SEARCH REPORT

International application No.

PCT/SE 98/01272

Patent document cited in search report	Publication date	Patent family member(s)	Publication date
EP 0588271 A1	23/03/94	SE 0588271 T3 AT 165942 T AU 668748 B AU 4607593 A DE 69318361 D ES 2116378 T IT 1255602 B NZ 248624 A	15/05/98 16/05/96 24/03/94 00/00/00 16/07/98 09/11/95 26/01/96
DE 1960041	19/11/70	AT 293972 A,B BE 741154 A CA 921059 A CH 507407 A DK 125336 B FR 2044103 A GB 1290191 A NL 6919314 A US 3658316 A	15/09/71 01/04/70 13/02/73 15/05/71 05/02/73 19/02/71 20/09/72 16/11/70 25/04/72
US 5335366 A	02/08/94	AU 6131894 A CA 2148355 A DE 4491705 T EP 0669060 A GB 9509910 D WO 9422235 A WO 9531048 A	11/10/94 29/09/94 07/12/95 30/08/95 00/00/00 29/09/94 16/11/95