



(19) **United States**

(12) **Patent Application Publication**

Edwin et al.

(10) **Pub. No.: US 2001/0025131 A1**

(43) **Pub. Date: Sep. 27, 2001**

(54) **METHODS FOR MAKING A SUPPORTED GRAFT**

(76) Inventors: **Tarun J. Edwin**, Chandler, AZ (US); **Rajagopal R. Kowligi**, Phoenix, AZ (US); **Brendan McCrea**, Ballwin, MO (US); **Chris Banas**, San Antonio, TX (US)

1995, now Pat. No. 5,749,880, which is a continuation-in-part of application No. 08/401,871, filed on Mar. 10, 1995, now Pat. No. 6,124,523.

**Publication Classification**

(51) **Int. Cl.<sup>7</sup>** ..... **A61F 2/06**; A61F 2/04  
(52) **U.S. Cl.** ..... **600/36**; 623/1.13

Correspondence Address:

**Todd W. Wight**  
**Morrison & Foerster LLP**  
**555 West Fifth Street**  
**Los Angeles, CA 90013-1024 (US)**

(57) **ABSTRACT**

Shape memory alloy and elastically self-expanding endoluminal support structures which are at least partially encapsulated in a substantially monolithic expanded polytetrafluoroethylene ("ePTFE") covering. An endoluminal stent, which has a reduced diametric dimension for endoluminal delivery and a larger in vivo final diametric diameter, is encapsulated in an ePTFE covering which circumferentially covers both the luminal and abluminal walls along at least a portion of the longitudinal extent of the endoluminal stent. The shape memory endoluminal stent is fabricated from a shape memory alloy which exhibits either shape memory or pseudoelastic properties or from an elastic material having an inherent spring tension such as spring steel, braided stainless steel wire, or composite materials, such as woven or braided carbon fibers.

(21) Appl. No.: **09/855,918**

(22) Filed: **May 15, 2001**

**Related U.S. Application Data**

(60) Division of application No. 08/999,583, filed on Dec. 22, 1997, now Pat. No. 6,264,684, which is a continuation-in-part of application No. PCT/US95/16497, filed on Dec. 8, 1995, which is a continuation-in-part of application No. 08/508,033, filed on Jul. 27,

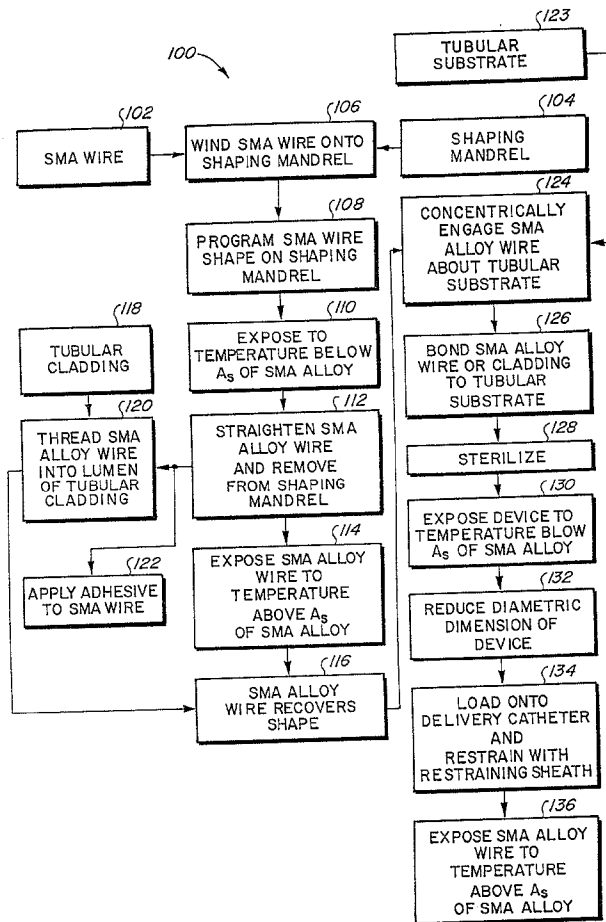

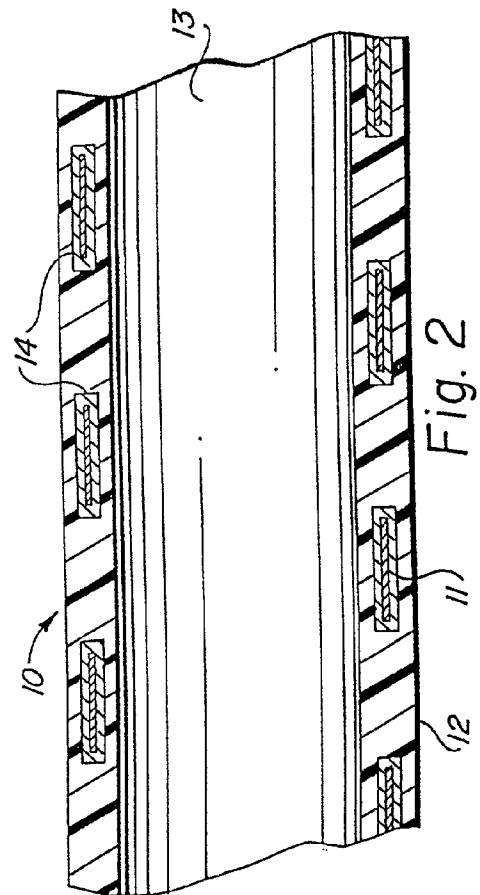
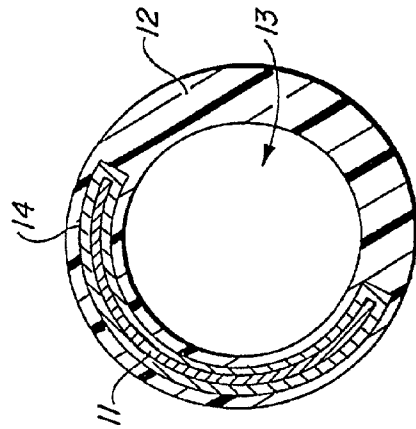
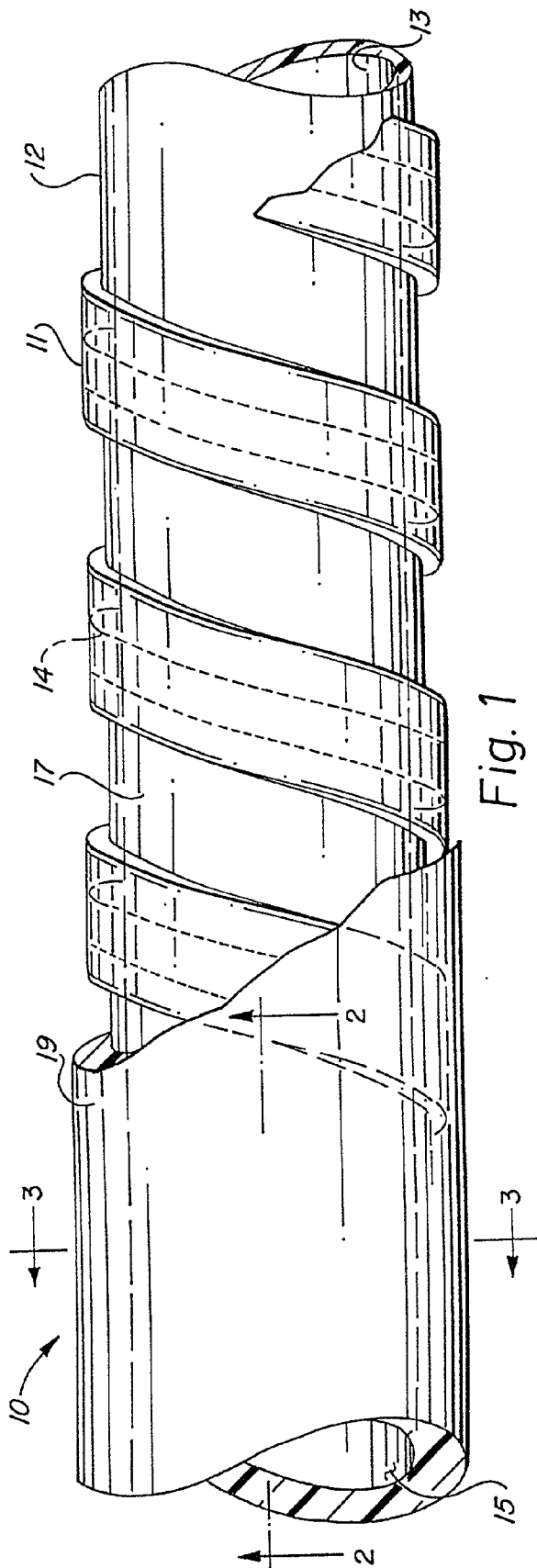

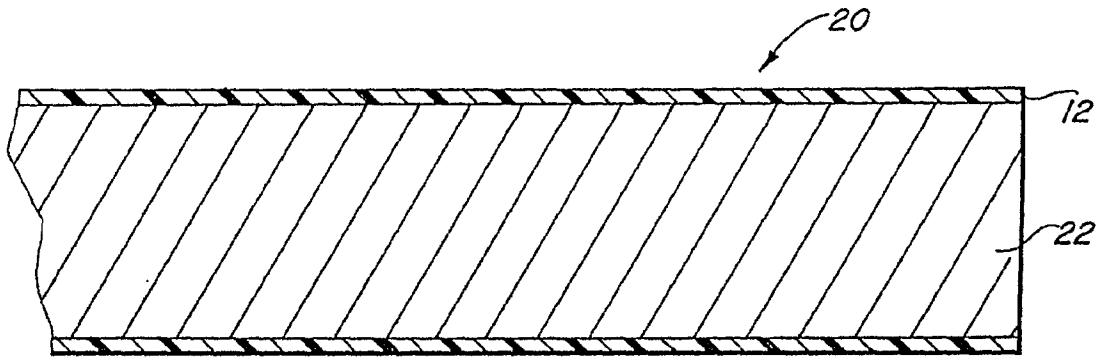

Fig. 4A

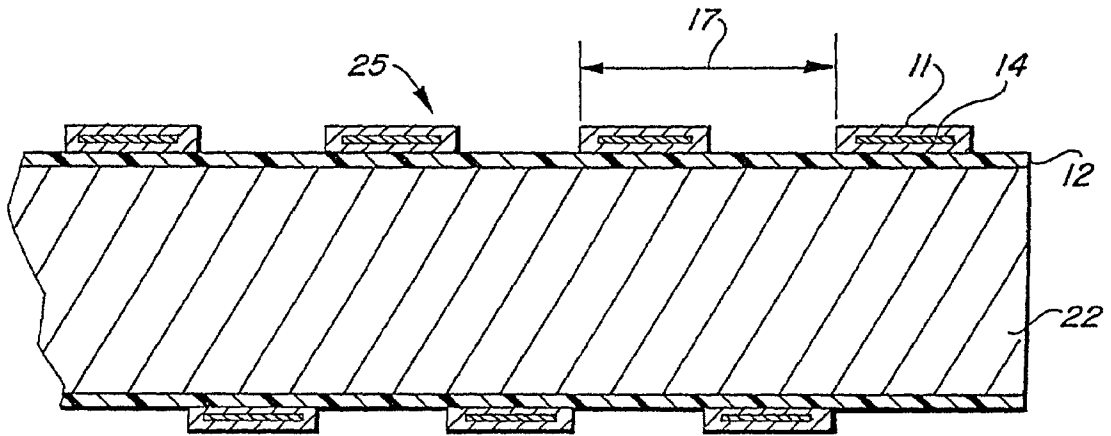

Fig. 4B

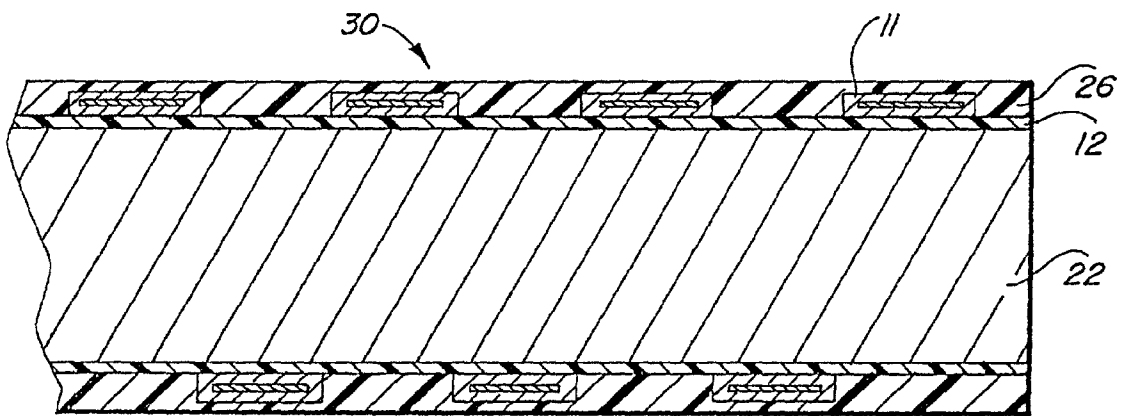

Fig. 4C

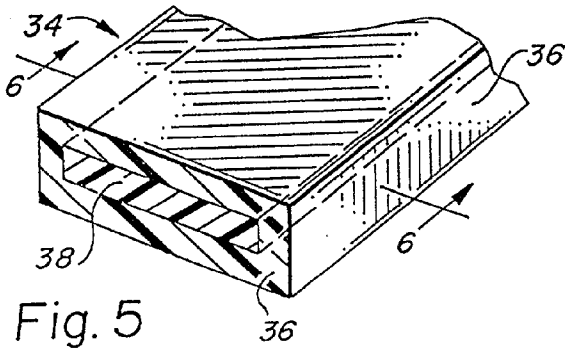

Fig. 5

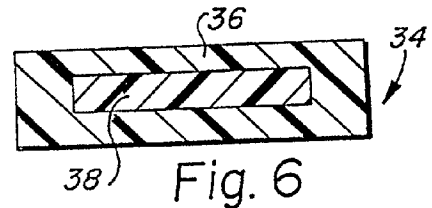

Fig. 6

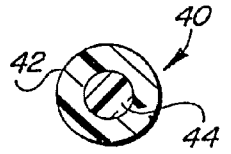

Fig. 8

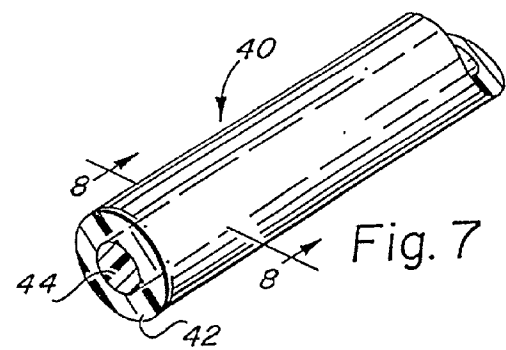

Fig. 7

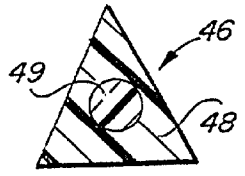

Fig. 9

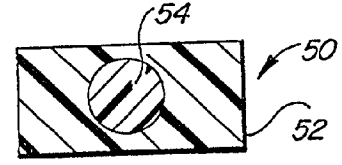

Fig. 10

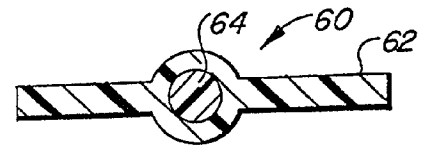

Fig. 11

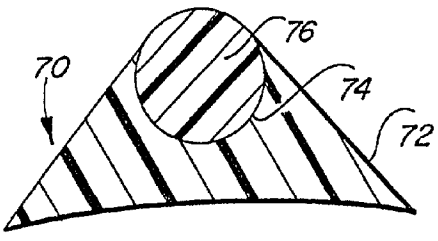

Fig. 12

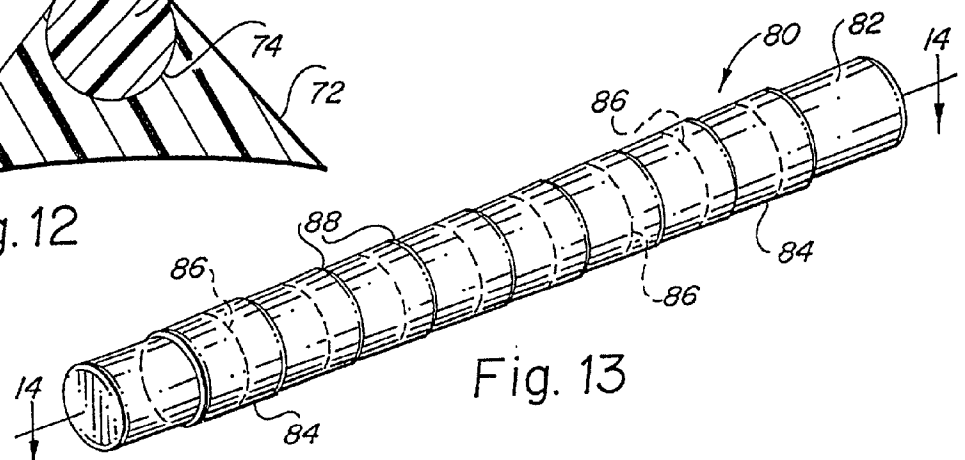

Fig. 13

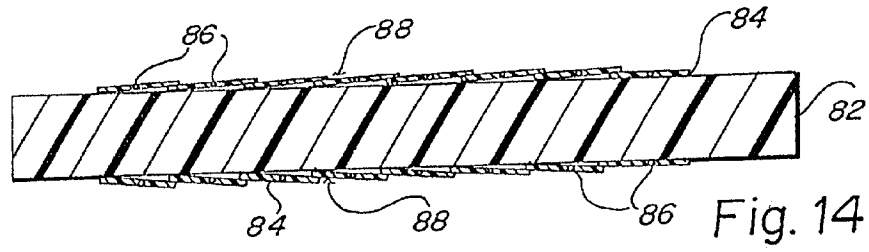

Fig. 14

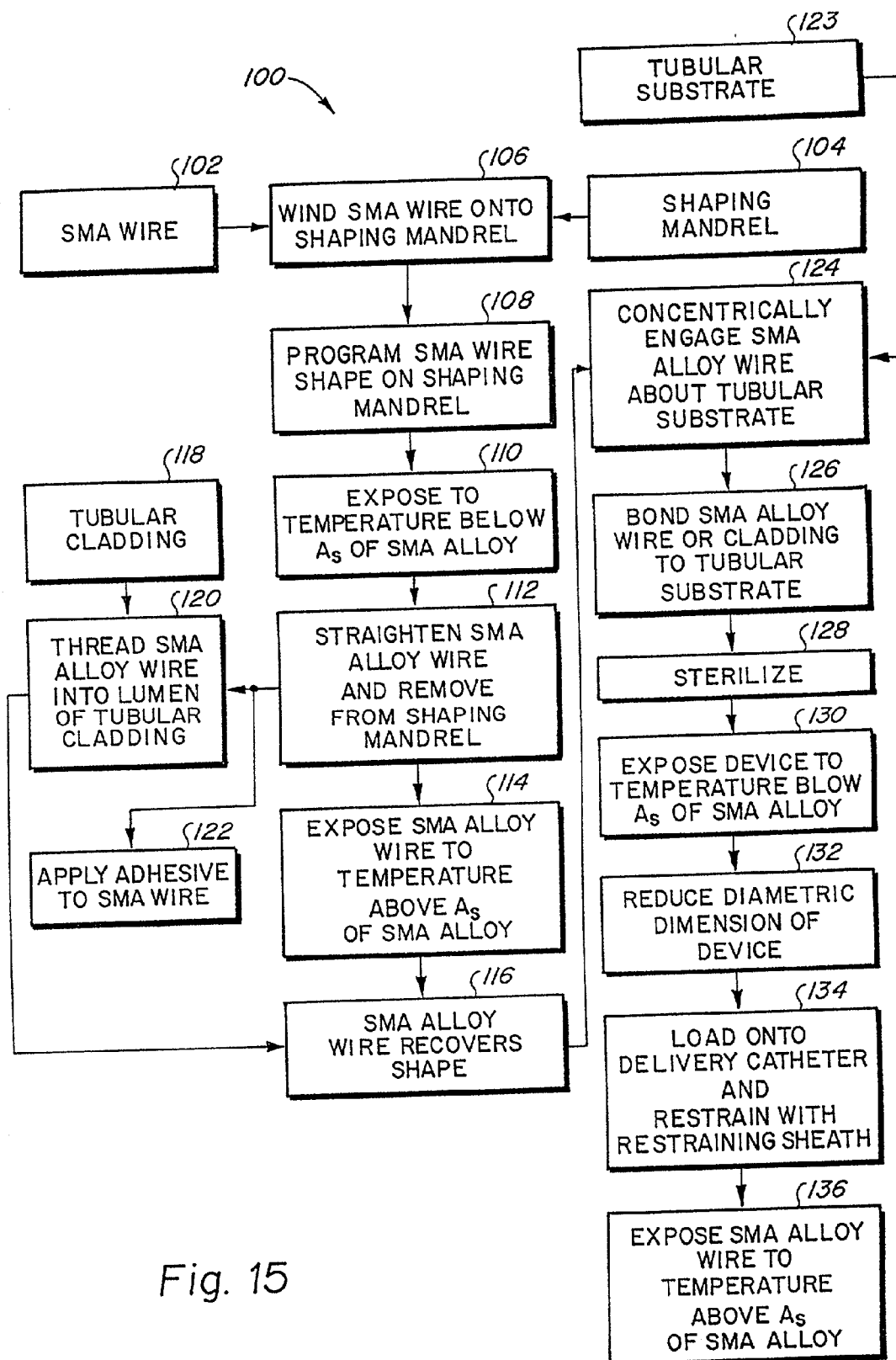

Fig. 15

## METHODS FOR MAKING A SUPPORTED GRAFT

### CROSS-REFERENCE TO RELATED APPLICATIONS

[0001] This application is a continuation-in-part of co-pending patent application Ser. No. PCT/US/95/16497, published as International Publication No. WO 97/21401, filed Dec. 8, 1995, co-pending patent application Ser. No. 08/833,797, filed Apr. 9, 1997, which is a continuation-in-part of co-pending patent application Ser. No. 08/508,033 filed Jul. 27, 1995 which is a continuation-in-part of co-pending patent application Ser. No. 08/401,871, filed Mar. 10, 1995, and co-pending U.S. patent application Ser. No. 08/794,871, filed Feb. 5, 1997. This application and each of the foregoing co-pending patent applications are commonly assigned.

### BACKGROUND OF THE INVENTION

[0002] The present invention relates generally to implantable intraluminal devices, particularly intraluminal grafts. Intraluminal stents are implanted in order to maintain luminal patency, typically after interventional methods have been employed to restore luminal patency from a diseased state, exclude an aneurysmal condition, bypass an occluded or obstructed anatomical region or to shunt body fluids. Surgically implantable prosthetics, particularly vascular prostheses, have been employed for many years. Expanded polytetrafluoroethylene (ePTFE) vascular grafts have been used as biocompatible implants for many years and the use of ePTE as a bio-inert barrier material in intraluminal applications is well documented. Conventional ePTFE vascular grafts, however, typically lack sufficient diametric mechanical rigidity to maintain luminal patency in intraluminal applications. Conventional externally supported ePTFE vascular grafts, such as the IMPRA Flex-Graft or the Gore Ring Graft, have an external beading of helically wound non-expanded or solid polytetrafluoroethylene, or of solid fluorinated ethylene-propylene co-polymer (FEP). Non-expanded or solid polytetrafluoroethylene is significantly more rigid than the ePTFE material due to its higher density and absence of interstitial voids. These externally supported ePTFE vascular grafts are not well-suited to interventional intraluminal procedures due to their inability to assume a reduced profile suitable for percutaneous delivery using a catheter and their inability to recover an enlarged diametric dimension in vivo.

[0003] Most intraluminal stents are formed of an open lattice fashioned either to be elastically deformable, such as in the case of self-expanding stainless steel spring stents, plastically deformable, such as in the case of balloon-expandable stainless steel PALMAZ stents, or thermally expandable such as by employing shape memory properties of the material used to form the stent. A common problem of most conventional intraluminal stents is re-occlusion of the vessel after stent placement. Tissue ingrowth and neointimal hyperplasia significantly reduces the open diameter of the treated lumen over time, requiring additional therapies.

[0004] The present invention makes advantageous use of the known biocompatible and material properties of ePTFE vascular grafts, and adds an abluminal supporting structure capable of being diametrically reduced to an intraluminal delivery profile and self-expanding in vivo to conform to the anatomical topography at the site of intraluminal implanta-

tion. More particularly, the present invention consists of an ePTFE substrate material, such as that described in co-pending U.S. patent application Ser. No. 08/794,871, filed Feb. 5, 1997, as a carrier for a helically wound, open cylindrical support structure made of a shape memory alloy.

[0005] The inventive intraluminal stent-graft device may be implanted either by percutaneous delivery using an appropriate delivery system, a cut-down procedure in which a surgical incision is made and the intraluminal device implanted through the surgical incision, or by laparoscopic or endoscopic delivery.

[0006] Shape memory alloys are a group of metal alloys which are characterized by an ability to return to a defined shape or size when subjected to certain thermal or stress conditions. Shape memory alloys are generally capable of being plastically deformed at a relatively low temperature and, upon exposure to a relatively higher temperature, return to the defined shape or size prior to the deformation. Shape memory alloys may be further defined as one that yields a thermoelastic martensite. A shape memory alloy which yields a thermoelastic martensite undergoes a martensitic transformation of a type that permits the alloy to be deformed by a twinning mechanism below the martensitic transformation temperature. The deformation is then reversed when the twinned structure reverts upon heating to the parent austenite phase. The austenite phase occurs when the material is at a low strain state and occurs at a given temperature. The martensite phase may be either temperature induced martensite (TIM) or stress-induced martensite (SIM). When a shape memory material is stressed at a temperature above the start of martensite formation, denoted  $M_s$ , where the austenitic state is initially stable, but below the maximum temperature at which martensite formation can occur, denoted  $M_d$ , the material first deforms elastically and when a critical stress is reached, it begins to transform by the formation of stress-induced martensite. Depending upon whether the temperature is above or below the start of austenite formation, denoted  $A_s$ , the behavior when the deforming stress is released differs. If the temperature is below  $A_s$ , the stress-induced martensite is stable, however, if the temperature is above  $A_s$ , the martensite is unstable and transforms back to austenite, with the sample returning to its original shape. U.S. Pat. Nos. 5,597,378, 5,067,957 and 4,665,906 disclose devices, including endoluminal stents, which are delivered in the stress-induced martensite phase of shape memory alloy and return to their pre-programmed shape by removal of the stress and transformation from stress-induced martensite to austenite.

[0007] Shape memory characteristics may be imparted to a shape memory alloy by heating the metal at a temperature above which the transformation from the martensite phase to the austenite phase is complete, i.e., a temperature above which the austenite phase is stable. The shape imparted to the metal during this heat treatment is the shape "remembered." The heat treated metal is cooled to a temperature at which the martensite phase is stable, causing the austenite phase to transform to the martensite phase. The metal in the martensite phase is then plastically deformed, e.g., to facilitate its delivery into a patient's body. Subsequent heating of the deformed martensite phase to a temperature above the martensite to austenite transformation temperature, e.g., body temperature, causes the deformed martensite phase to

transform to the austenite phase and during this phase transformation the metal reverts back to its original shape.

**[0008]** The term "shape memory" is used in the art to describe the property of an elastic material to recover a pre-programmed shape after deformation of a shape memory alloy in its martensitic phase and exposing the alloy to a temperature excursion through its austenite transformation temperature, at which temperature the alloy begins to revert to the austenite phase and recover its preprogrammed shape. The term "pseudoelasticity" is used to describe a property of shape memory alloys where the alloy is stressed at a temperature above the transformation temperature of the alloy and stress-induced martensite is formed above the normal martensite formation temperature. Because it has been formed above its normal temperature, stress-induced martensite reverts immediately to undeformed austenite as soon as the stress is removed provided the temperature remains above the transformation temperature.

**[0009]** The present invention employs a wire member made of either a shape memory alloy, preferably a nickel-titanium alloy known as NITINOL, spring stainless steel or other elastic metal or plastic alloys, or composite material, such as carbon fiber. It is preferable that the wire member have either a generally circular, semi-circular, triangular or quadrilateral transverse cross-sectional profile. Where a shape memory alloy material is employed, pre-programmed shape memory is imparted to the wire member by helically winding the wire member about a cylindrical programming mandrel having an outer diametric dimension substantially the same, preferably within a tolerance of about +0 to -15%, as the ePTE substrate and annealing the programming mandrel and the wire member at a temperature and for a time sufficient to impart the desired shape memory to the wire member. After annealing, the wire member is removed from the programming mandrel, straightened and helically wound about the abluminal wall surface of an ePTFE tubular member at a temperature below the  $A_s$  of the shape memory alloy used to form the wire member.

**[0010]** In order to facilitate bonding of the wire member to the ePTFE tubular member, it is preferable that a bonding agent capable of bonding the support wire member to the ePTFE tubular member be used at the interface between the wire member and the ePTFE tubular member. Suitable biocompatible bonding agents may be selected from the group consisting of polytetrafluoroethylene, polyurethane, polyethylene, polypropylene, polyamides, polyimides, polyesters, polypropylenes, polyethylenes, polyfluoroethylenes, silicone fluorinated polyolefins, fluorinated ethylene/propylene copolymer, perfluoroalkoxy fluorocarbon, ethylene/tetrafluoroethylene copolymer, and polyvinylpyrrolidone. The bonding agent may constitute an interfacial layer intermediate the wire member and the ePTFE tubular member, or may be a polymeric cladding at least partially concentrically surrounding the wire member. Where a cladding is provided, the cladding is preferably a polymeric material selected from the group consisting of polytetrafluoroethylene, polyurethane, polyethylene, polypropylene, polyamides, polyimides, polyesters, polypropylenes, polyethylenes, polyfluoroethylenes, silicone fluorinated polyolefins, fluorinated ethylene/propylene copolymer, perfluoroalkoxy fluorocarbon ethylene/tetrafluoroethylene copolymer, and polyvinylpyrrolidone. The cladding may be either co-extruded with the wire member, extruded as a tube into which the wire

member is concentrically inserted after annealing the wire member, or provided as an elongate member which a longitudinal recess which co-axially receives the wire member. Where the bonding agent employed is a melt thermoplastic which has a melt point below the crystalline melt point of polytetrafluoroethylene, the melt thermoplastic bonding agent and the wire member are wound about the ePTFE tubular member, and constrained thereupon, such as by application of circumferential pressure, then the assembly is then exposed to the melt temperatures without longitudinally supporting the assembly. However, where the bonding agent is polytetrafluoroethylene, bonding of the wire member to the ePTFE tubular member requires exposing the assembly to temperatures above the crystalline melt point of polytetrafluoroethylene in order to effectuate bonding of the wire member to the ePTFE. This is preferably accomplished by introducing the assembly into a sintering oven while the assembly is on a mandrel and the assembly secured to the mandrel by an external helical wrapping of TEFLON tape applied to opposing ends of the assembly to longitudinally constrain the assembly and reduce or eliminate the tendency of the assembly to longitudinally foreshorten during sintering.

#### SUMMARY OF THE INVENTION

**[0011]** It is a primary objective of the present invention to provide a self-supporting, self-expanding stent-graft device which is capable of being delivered to an anatomical position within a human body in a first constrained configuration, positioned in vivo at a desired anatomical site, and the constraint released to permit the stent-graft device to transform to a radially enlarged second configuration.

**[0012]** It is another primary objective of the present invention to provide a stent-graft device which consists generally of tubular member fabricated of a biocompatible polymer selected from the group of microporous expanded polytetrafluoroethylene ("ePTFE"), polyethylene, polyethylene terephthalate, polyurethane and collagen, and at least one winding of an elastically self-expanding wire coupled to either the abluminal or luminal surfaces of the ePTFE tubular member or interdisposed between concentrically positioned ePTFE tubular members.

**[0013]** It is a further objective of the present invention to couple the at least one winding of the elastically self-expanding wire to the ePTFE tubular member by cladding a support wire in a polymeric material which has a melt point less than or equal to that of the ePTFE tubular member and below the  $A_s$  temperature of the shape memory alloy metal wire.

**[0014]** It is a further objective of the present invention to provide an adhesive interlayer for bonding the shape memory alloy metal wire to the tubular member, the adhesive interlayer being selected from the group consisting of polytetrafluoroethylene, polyurethane, polyethylene, polypropylene, polyamides, polyimides, polyesters, polypropylenes, polyethylenes, polyfluoroethylenes, silicone, fluorinated polyolefins, fluorinated ethylene/propylene copolymer, perfluoroalkoxy fluorocarbon, ethylene/tetrafluoroethylene copolymer, and polyvinylpyrrolidone.

**[0015]** It is another objective of the present invention to provide a method for making a self-expanding stent-graft device comprised generally of an ePTFE tubular member

and at least one winding of a shape memory alloy metal wire coupled to the abluminal surface of the ePTFE tubular member.

[0016] These and other objects, features and advantages of the present invention will be better understood by those of ordinary skill in the art from the following more detailed description of the present invention taken with reference to the accompanying drawings and its preferred embodiments.

#### BRIEF DESCRIPTION OF THE DRAWINGS

[0017] FIG. 1 is a side elevational view of a supported intraluminal graft in accordance with a preferred embodiment of the present invention.

[0018] FIG. 2 is a cross-sectional view taken along line 2-2 of FIG. 1.

[0019] FIG. 3 is a cross-sectional view taken along line 3-3 of FIG. 1.

[0020] FIG. 4A is a side elevational cross-sectional view of a graft member mounted onto a mandrel in accordance with a preferred embodiment of the method of the present invention.

[0021] FIG. 4B is a side elevational cross-sectional view as in FIG. 4A with support member wrapped about an abluminal surface of the graft member.

[0022] FIG. 4C is a side elevational cross-sectional view as in FIGS. 4A and 4B illustrating an abluminal covering concentrically superimposed over the support member and the graft member.

[0023] FIG. 5 is a perspective view of a ribbon member clad in a polymeric covering in accordance with the present invention.

[0024] FIG. 6 is a cross-sectional view taken along line 6-6 of FIG. 5.

[0025] FIG. 7 is a perspective view of a wire member clad in a polymeric covering in accordance with the present invention.

[0026] FIG. 8 is a cross-sectional view taken along line 8-8 of FIG. 7.

[0027] FIG. 9 is a diagrammatic cross-sectional view of a first embodiment of a support member encapsulated in a shaped polymeric cladding covering.

[0028] FIG. 10 is a diagrammatic cross-sectional view of a second embodiment of a support member encapsulated in a shaped polymeric cladding covering.

[0029] FIG. 11 is a diagrammatic cross-sectional view of a third embodiment of a support member encapsulated in a shaped polymeric cladding covering.

[0030] FIG. 12 is a diagrammatic cross-sectional view of a fourth embodiment of a support member coupled to a shaped polymeric cladding covering.

[0031] Figure 13 is a perspective view of an alternative preferred embodiment of the supported intraluminal graft in accordance with the present invention.

[0032] FIG. 14 is a cross-sectional view taken along line 14-14 of Figure 13.

[0033] FIG. 15 is a process flow diagram illustrating the process steps for making the supported intraluminal graft in accordance with the method of the present invention.

#### DETAILED DESCRIPTION OF THE PREFERRED EMBODIMENTS

[0034] The shape memory alloy supported intraluminal graft 10 of the present invention consists generally of a tubular substrate 12 having a central lumen 13 passing through an entire longitudinal extent of the tubular substrate. The tubular substrate 12 has a luminal wall surface 15 adjacent the central lumen 13 and an abluminal wall surface 17 opposing the central lumen 13. A support member 14 is provided and is preferably at least partially covered by a polymeric cladding 11. The polymeric clad support member 14 is circumferentially disposed about and joined to the abluminal wall surface 17 of the tubular substrate 12, such as by helically winding the polymeric clad support member 14 about the abluminal surface 17 of the tubular substrate 12. Optionally, a second tubular substrate 19, having an inner diameter sufficiently dimensioned to be concentrically engaged about the abluminal wall surface 17 of the tubular substrate 12 and the polymeric clad support member 14, may be provided.

[0035] In accordance with a first preferred embodiment of the present invention, and with particular reference to FIGS. 1-3, there is provided the inventive supported intraluminal graft 10 comprised of a tubular 12 made of a biocompatible polymeric material, such as expanded polytetrafluoroethylene ("ePTFE"), polyethylene terephthalate ("PET") such as that marketed and sold under the trademark DACRON, polyethylene, or polyurethane. Expanded PTFE substrate materials are preferably made by ram extruding an admixture of polytetrafluoroethylene resin and a hydrocarbon lubricant to form a tubular extrudate, drying off the hydrocarbon lubricant, longitudinally expanding the dried tubular extrudate, then sintering the longitudinally expanded dried tubular extrudate at a temperature above the crystalline melt point of polytetrafluoroethylene. The resulting tubular ePTFE material has a microporous microstructure which is composed of spaced-apart nodes interconnected by fibrils, with the fibrils being oriented parallel to the longitudinal axis of the ePTFE tube and parallel to the axis of longitudinal expansion. U.S. Pat. Nos. '390 and '566, both issued to Gore, teach processes for making ePTFE tubular substrates and are hereby incorporated by reference as teaching processes to make ePTFE tubular and planar materials. A tubular substrate may also be made by weaving yarn, made of either polyester or ePTFE, into a tubular structure as is well known in the art. Additionally, the tubular substrate 12 may have a cylindrical profile having a substantially uniform internal diameter along its longitudinal axis, or may have a tapered sidewall in which the tubular substrate 12 assumes a generally frustoconical shape in which the internal diameter of the tubular substrate 12 increases or decreases along the longitudinal axis of the tubular substrate 12. Alternatively, the tubular substrate 12 may have at least one region of stepped diameter in which the internal diameter of the tubular substrate changes at a discrete longitudinal section of the tubular substrate 12.

[0036] In accordance with a first preferred embodiment of the present invention, the tubular substrate 12 is an extruded, longitudinally expanded and sintered ePTFE tubular mem-



ber which has been radially expanded from an initial luminal inner diameter of between about 1.5 mm to about 6 mm to a final luminal inner diameter of between about 3 mm to about 18 mm. Thus, tubular substrate **12** is initially fabricated at a first relatively smaller diametric dimension, dried of the hydrocarbon lubricant, and sintered, then radially expanded by application of an radially outwardly directed force applied to the luminal wall surface **15** of the tubular substrate **12**, which radially deforms the wall of the tubular substrate **12** from an initial luminal inner diameter, denoted  $D_1$ , to a second, enlarged luminal inner diameter, denoted  $D_2$ . Alternatively, tubular substrate **12** may be provided as an extruded, longitudinally expanded and sintered ePTFE tubular member having an inner diameter equivalent to the final inner diameter of the supported intraluminal graft, e.g., extruded to a luminal diameter of between about 3 mm to about 18 mm, and a wall thickness sufficient to acceptably minimize the delivery profile of the supported intraluminal graft. Suitable wall thicknesses for the non-radially expanded ePTFE tubular member are considered less than or equal to about 0.3 mm for delivery to peripheral anatomic passageways.

[0037] The tubular substrate **12** is preferably radially expanded by loading the tubular substrate **12**, in its fully or partially sintered state, onto an inflation balloon such that the tubular substrate **12** is concentrically engaged upon the inflation balloon, introducing the inflation balloon and tubular substrate **12** into a tubular housing defining a generally cylindrical cavity having an inner diameter corresponding to the maximum desired outer diameter of the final shape memory alloy supported graft, and applying a fluid pressure to the inflation balloon to inflate the inflation balloon and radially deform the tubular substrate **12** into intimate contact with the generally cylindrical cavity. Pressure is maintained within the inflation balloon for a period of time sufficient to minimize the inherent recoil property of the ePTFE material in the tubular substrate **12**, then the pressure is relieved and the inflation balloon permitted to deflate. The radially deformed tubular substrate, now having an inner luminal diameter  $D_2$ , is removed from the generally cylindrical cavity for subsequent processing.

[0038] During radial expansion of the tubular substrate **12** from  $D_1$  to  $D_2$ , the node and fibril microstructure of the ePTFE tubular substrate is deformed. The nodes, which have an orientation perpendicular to the longitudinal axis of the tubular substrate **12** and parallel to the radial axis of the tubular substrate **12**, deform along the longitudinal axis of each node to form elongated columnar structures, while the length of the fibrils interconnecting adjacent pairs of nodes in the longitudinal axis of the tubular substrate **12**, remains substantially constant. The fibril length is also referred to herein as the "internodal distance."

[0039] A support member **14**, which is preferably made of an elastic wire material selected from the group of thermoelastic or shape memory alloys, spring stainless steel, elastic metal or plastic alloys, or composite materials, such as woven carbon fibers. Where a shape memory alloy is employed, it is important that the shape memory alloy have a transition temperature below human body temperature, i.e., 37 degrees Celsius, to enable the shape memory alloy to undergo transformation to the austenite phase when the shape memory alloy wire member is exposed to human body temperature in vivo. In accordance with the best mode

currently known for the present invention, the preferred shape memory alloy is a near equiatomic alloy of nickel and titanium.

[0040] To facilitate attachment of the elastic or thermoelastic wire member **14** to the tubular substrate **12**, it is contemplated that a polymeric cladding **11** be provided to at least partially cover the support wire member **14** and facilitate adhesion between the support wire member **14** and the abluminal wall surface **17** of the tubular substrate **12**. In accordance with the best mode for practicing the present invention, it is preferable that the polymeric cladding **11** be selected from the group of biocompatible polymeric materials consisting of polytetrafluoroethylene, polyurethane, polyethylene, polypropylene, polyamides, polyimides, polyesters, polypropylenes, polyethylenes, polyfluoroethylenes, silicone, fluorinated polyolefins, fluorinated ethylene/propylene copolymer, perfluoroalkoxy fluorocarbon, ethylene/tetrafluoroethylene copolymer, and polyvinylpyrrolidone. As will hereinafter be described more fully, the polymeric cladding **11** may be coupled to the support wire member **14** by any of a variety of known methodologies. For example, the polymeric cladding **11** may be co-extruded with the support wire member **14**, the polymeric cladding **11** may be extruded with an opening passing through the polymeric cladding **11** along its longitudinal axis and dimensioned to receive the support wire member **14** there through, the polymeric cladding **11** may have a longitudinally extending recess dimensioned to receive and retain the support wire member **14** therein, or the polymeric cladding **11** may be applied onto the support wire member **11** in dispersion form, such as by dip-coating or spraying, and the solvent or aqueous vehicle dried thereby forming a covering on the support wire member **11**.

[0041] The support wire member **14** in its polymeric cladding **11** is circumferentially joined to the abluminal wall surface **17** of the tubular substrate **12**, such as by helically winding at least one length of polymeric clad support wire member **14** in a regular or irregular helical pattern, or by applying the polymeric clad support wire member **14** as a series of spaced-apart circumferential rings, along at least a portion of the longitudinal axis of the abluminal wall surface **17** of the tubular substrate **12**. It is preferable that the tubular substrate **12** be mounted onto a supporting mandrel [not shown] having an outer diameter closely tolerated to the inner diameter of the tubular substrate **12** to permit the tubular substrate **12** to be placed thereupon and secured thereto without deforming the tubular substrate **12**.

[0042] A second tubular member **19** may, optionally, be concentrically engaged about the tubular member **12** and the polymeric clad support wire member **14**. As more clearly depicted in FIGS. 2-3, where the second tubular member **19** is employed and disposed circumferentially about the tubular member **12** and the polymeric clad support wire member **14**, the tubular member **12** and the second tubular member **19** encapsulate the polymeric clad support wire member **14**. Where the tubular member **12** and the second tubular member **19** are both made of longitudinally expanded ePTFE, each will have a microporous microstructure in which the fibrils are oriented parallel to the longitudinal axis of each of the tubular member **12** and the second tubular member **19**, throughout their respective wall thicknesses. The encapsulation of the polymeric clad support wire member **14** is best accomplished by providing both the tubular

member 12 and the second tubular member 19 as unsintered or partially sintered tubes. After wrapping the polymeric clad support wire member 14 about the abluminal surface of the tubular member 12, and circumferentially engaging the second tubular member 19 thereabout, it is preferable to apply a circumferential pressure to the assembly, while the assembly is on the supporting mandrel [not shown]. Circumferential pressure may be applied to the assembly by, for example, helically wrapping tetrafluoroethylene film tape about the abluminal surface of the second tubular member 19 along its longitudinal axis, or by securing opposing ends of the assembly on the supporting mandrel, and rolling the assembly to calendar the assembly. After the circumferential pressure is applied to the assembly, the assembly is then introduced into either a convection or radiant heating oven, set at a temperature above the melt point of the material used to fabricate the tubular member 12, the second tubular member 19 and/or the polymeric cladding 11, for a period of time sufficient to bond the tubular member 12, the second tubular member 19 and the polymeric cladding 11 into a substantially monolithic, unitary structure. Where polytetrafluoroethylene is used, it has been found that it is preferable to heat the assembly in a radiant heating oven.

[0043] FIGS. 4A-4C depict the method steps for making the inventive shape memory alloy supported intraluminal graft 10. With a first step 20, tubular member 12 is concentrically engaged onto a supporting mandrel 22 such that the supporting mandrel 22 resides within the lumen of the tubular member 12. A helical winding of polymeric clad support wire member 14 is applied about the abluminal wall surface 17 of the tubular member 12 at step 25. The helical windings have an interwinding distance 27 which is preferably at least one times the distance 29 which represents the width of the polymer cladding 11, in the case of a planar polymer cladding 11, or the diameter, in the case of a tubular polymer cladding 11 having a circular transverse cross-section. The helical winding of the polymeric clad support wire member 14 contacts the abluminal wall surface 17 of the tubular member 12 at an interfacial region 28. According to one preferred embodiment of the present invention there is provided an adhesive material 23 selected from the group consisting of polytetrafluoroethylene, polyurethane, polyethylene, polypropylene, polyamides, polyimides, polyesters, polypropylenes, polyethylenes, polyfluoroethylenes, silicone, fluorinated polyolefins, fluorinated ethylene/propylene copolymer, perfluoroalkoxy fluorocarbon, ethylene/tetrafluoroethylene copolymer, and polyvinylpyrrolidone. The adhesive material is preferably applied to the interfacial region 28 of the polymeric clad support wire member 14, but may also be applied in a pattern directly to a surface of the tubular substrate and the SMA wire member 14 brought into contact with the adhesive material. In this manner, as the polymeric clad support wire member 28 is helically applied to the abluminal wall surface 17 of the tubular member 12, the adhesive material 23 forms an interlayer intermediate the polymeric clad support wire member 28 and the abluminal wall surface 17 of the tubular member 12.

[0044] Where the selected adhesive material 23 has a melt point less than the crystalline melt point of polytetrafluoroethylene, i.e., about 327 degrees Centigrade, the resulting assembly of step 25 may be introduced into a heating oven set at the melt temperature of the selected adhesive material 23, for a period of time sufficient to melt the adhesive material 23 and impart an adhesive bond between the

polymeric clad support wire member 14 and the tubular member 12. On the other hand, where the selected adhesive material 23 is polytetrafluoroethylene, an external covering of a second tubular member 26 may be concentrically engaged about the assembly resulting from step 25, a circumferential pressure exerted to the second tubular member 26, thereby bringing the second tubular member 26, the polymer clad support wire member 11 and the tubular member 12 into intimate contact with one another, and the entire assembly introduced into a sintering oven set at a temperature above the crystalline melt point of polytetrafluoroethylene and for a period of time sufficient to meld the second tubular member 26 and the tubular member 12 to one another to form a resultant substantially monolithic structure which is substantially devoid of interfacial demarcations between the second tubular member 26 and the tubular member 12, with the polymer clad support wire member 14 residing intermediate there between.

[0045] Turning now to FIGS. 5-12, there is depicted numerous alternate configurations of the polymer clad support wire member 14. FIGS. 5 and 6 depict a first embodiment of the polymer clad support wire member 34 in which the support wire member is formed as a planar ribbon wire 38 having a generally tubular box-like polymer cladding 36 provided about the outer surfaces of the planar ribbon wire 38. In the transverse cross-sectional view of FIG. 6 it will be seen that both the planar ribbon wire 38 and the polymer cladding 36 have generally quadrilateral cross-sectional configurations.

[0046] FIGS. 7-8 depict a second embodiment of the polymer clad support wire member 40 in which the support wire member is formed as a cylindrical wire 44 having a generally tubular polymer cladding 42 provided about the outer circumference of the planar ribbon wire 44. In the transverse cross-sectional view of FIG. 8 it will be seen that both the cylindrical wire 44 and the polymer cladding 42 have generally circular cross-sectional configurations.

[0047] FIGS. 9-12 are provided in the transverse cross-sectional views only, it being understood that like FIGS. 5 and 7, each of the embodiments depicted in FIGS. 9-12 have corresponding perspective configurations. FIG. 9 depicts a third embodiment of the polymer clad support wire member 46 in which the support wire member is formed as a cylindrical wire 49 having a generally triangular-shaped polymer cladding 48, with a central longitudinal cylindrical bore to accommodate the cylindrical wire 49 therein, which is provided about the outer surfaces of the cylindrical wire 49. A fourth embodiment of the polymer clad support wire member 50 is depicted in FIG. 10. Polymer clad support wire member 50 consists generally of a polymer cladding 52 having a plurality of planar surfaces and having a generally quadrilateral transverse cross-sectional shape, while the support wire member 54 is generally cylindrical with a generally circular transverse cross-section. As depicted in FIG. 11, a fifth embodiment of the polymer clad support wire member 60 is depicted. Here, the support wire member 54 has a generally cylindrical shape with a generally circular transverse cross-section, while the polymer cladding 62 has a main body portion having a generally circular transverse cross-section, but has additional projections extending radially outward from the generally circular main body portion to increase the bonding surface area of the polymer clad support wire member 60. Finally, as depicted in FIG. 12, the

sixth embodiment of the polymer clad support wire member **70** is depicted. In accordance with this sixth embodiment there is provided a generally cylindrical support wire member **76** having a generally circular transverse cross-section, while the polymer cladding **72** is provided with a generally triangular cross-sectional shape, with hemispherical recess **74** formed in an apex of the generally triangular cross-sectional shape. The hemispherical recess **74** subtends at least a 180 degree arc and extends along a substantial longitudinal extent of the polymer cladding **72**. The generally cylindrical support wire member **76** is engaged in the hemispherical recess **74** and retained therein by an interference fit, or by other suitable means, such as an adhesive.

[**0048**] It will be understood by those skilled in the art, that each of the foregoing embodiments of the polymer clad support wire member may be made by pulltrusion methods in which the shape memory alloy wire member, having a pre-programmed austenite phase, is fed into an extruder during extrusion of the polymer cladding, or by extruding the polymer cladding with a central lumen, dimensioned appropriately to permit engagement of the shape memory alloy wire, then threading the support wire member into the central lumen of the polymer cladding.

[**0049**] Finally, an alternative embodiment of a shape memory alloy supported intraluminal graft **80** is depicted in **FIGS. 13 and 14**. The inventive shape memory alloy supported intraluminal graft **80** may be formed by helically wrapping a length of polymer clad **84** shape memory alloy wire **86** about a supporting winding mandrel, such that the polymer cladding **84** has overlapping regions **88** which form seams. The resulting assembly is then heated above the melt point of the polymer cladding **84** to join and seal the overlapping regions **88** to one another.

[**0050**] The inventive method **100** for making the inventive wire supported intraluminal graft, described above, is illustrated with reference to **FIG. 15**. An elastic or thermoelastic wire member is provided at step **102** along with a shaping mandrel **104**. The shaping mandrel **104** is preferably a solid cylindrical or tubular cylindrical stainless steel member capable of withstanding annealing temperatures of shape memory alloys. At step **106**, the wire member provided at step **102** is wound onto the shaping mandrel provided at step **104**. The wire member is preferably helically wound about the shaping mandrel such that adjacent windings are substantially uniformly spaced from one another. It is also contemplated that the wire member may be wound about the shaping mandrel in any of a wide number of configurations, including non-uniformly spaced windings long portions of the shaping mandrel, such that certain regions of the winding have higher and lower frequency windings than other regions, that the winding be shaped as adjacent circumferential loops such as that shape disclosed in Gianturco, U.S. Pat. No. 4,907,336 or Wiktor, U.S. Pat. No. 4,969,458, both hereby incorporated by reference as teaching a shape of winding suitable for use with the present invention, or virtually any other shape which is capable for forming an open tubular structural skeleton, including, without limitation, a helical winding having a plurality of sinusoidal bends along a length thereof, as taught by Wiktor, U.S. Pat. No. 4,886,062 or Pinchuck, U.S. Pat. No. 5,019,090, both hereby incorporated by reference as teaching alternative configurations of helical windings of wire members.

[**0051**] Where a thermoelastic shape memory alloy (SMA) wire member is utilized, the SMA wire member is wound about the shaping mandrel, the shape of the wound SMA wire member is programmed at step **108** by annealing the SMA wire member at a temperature and for a time sufficient to impart shape memory properties to the SMA wire member. At step **110**, the preprogrammed SMA alloy wire member is then exposed to temperature conditions below the  $M_f$  temperature of the SMA alloy. While it is maintained below the  $M_f$  temperature of the SMA alloy, the wire member is removed from the shaping mandrel and straightened to a linear shape at step **112**. If the SMA alloy wire member is to be covered with a cladding, a polymeric cladding is provided at step **118** and the SMA alloy wire member is threaded into the lumen of the tubular cladding at step **120**. It is preferable that steps **118** and **120** be performed while the SMA alloy wire member is maintained at a temperature below the  $M_f$  temperature of the SMA alloy to prevent shape recovery of the SMA alloy wire member. Alternatively, if no polymeric cladding is to be employed, but the SMA alloy wire member from step **112** is to be adhered, an adhesive material may be applied to the SMA alloy wire member at step **122**. Step **122** may be conducted while the SMA alloy wire member is at a temperature below the  $M_f$  temperature, however, due to the fact that most adhesives may not adhere to the SMA alloy wire member at such temperatures, the adhesive is preferably applied to the SMA alloy wire member while it is in the austenite state.

[**0052**] Where an elastic wire member, such as a support structure made from stainless steel spring wire, is employed, the shape programming described in the preceding paragraph may, of course, be omitted.

[**0053**] After application of the polymeric cladding at steps **118** and **120**, or after the adhesive is applied at step **122**, or where step **122** is conducted at a temperature below the  $M_f$  temperature of the SMA alloy, the SMA wire is then exposed to a temperature excursion to above the  $A_f$  temperature of the SMA alloy at step **114** so that the SMA alloy wire member recovers its programmed shape at step **116**. Where an elastic wire member is employed, it is not sensitive to temperature excursions and the temperature excursion step may be omitted.

[**0054**] A tubular substrate, made of, for example, extruded ePTFE, preferably extruded ePTFE which has been radially deformed from its nominal extruded diameter to an enlarged diameter, or woven polyester, is provided at step **123**. The wire member in its enlarged shape, which in the case of an SMA wire member is its programmed shape, or in the case of an elastic wire member, in its unstressed state, is concentrically engaged about the tubular substrate at step **124**, and joined to the tubular substrate at step **126** by thermally bonding the adhesive or the polymeric cladding to the abluminal or luminal surface of the tubular substrate. It is preferable that step **126** be conducted while the tubular substrate is supported by a support mandrel and that the SMA alloy wire member is retained in intimate contact with a surface of the tubular substrate with at least a portion of the wire member. The wire member, either in its clad or unclad state, may be retained in intimate contact against either by tension wrapping the wire member or by an external covering wrap of a release material, such as polytetrafluoroethylene tape, to cover at least a portion of the wire member.

[0055] After the wire member is joined to the tubular substrate, the assembly may optionally be sterilized at step 128, such as by exposure to ethylene oxide for a time and under appropriate conditions to sterilize the assembly. Where an SMA alloy wire member is employed, the assembly is then exposed to a temperature below the  $A_s$  temperature of the SMA alloy wire member at step 130 and the assembly is mechanically deformed to a smaller diametric profile at step 132. Where an elastic wire member is employed, the assembly is mechanically deformed to a smaller diametric profile at step 132 largely independent of temperature conditions. Step 132 may be performed by any suitable means to reduce the diametric profile of the assembly, such as by drawing it through a reducing die, manually manipulating the assembly to a reduced diametric profile, or folding the device. The reduced profile assembly is then loaded onto a delivery catheter and covered with a restraining sheath at step 134. Once loaded onto a delivery catheter and covered with a restraining sheath to prevent shape recovery. In the case where the wire member is an SMA alloy, loading the assembly onto a delivery catheter and covering with a restraining sheath requires that step 134 be performed at a temperature below the  $A_s$  temperature of the SMA alloy wire in order to prevent thermoelastic recovery of the SMA alloy wire member. Where, however, the wire member is fabricated of an elastic material, the loading step 134 is not largely temperature sensitive and may be performed at room temperature. While the wire member will exert shape recovery forces at room temperature, e.g., above the  $A_s$  temperature of the SMA alloy wire employed, the restraining sheath of the delivery catheter will prevent the SMA alloy wire member from recovering its programmed shape and carrying the tubular substrate to the programmed shape of the SMA alloy wire member. Optionally, the sterilization step 128 may also be performed after the assembly is loaded onto the delivery catheter at step 134.

[0056] While the present invention has been described with reference to its preferred embodiments and the best mode known to the inventor for making the inventive shape memory alloy supported intraluminal graft, it will be appreciated that variations in material selection for the polymer cladding, for the shape memory alloy, or process variations, such as the manner of winding the polymer clad support wire member about either a winding mandrel or a tubular or times and conditions of the manufacturing steps, including material selection, may be made without departing from the scope of the present invention which is intended to be limited only by the appended claims.

What is claimed is:

1. An endoluminal prosthesis, comprising:
  - an tubular substrate having an abluminal surface and a luminal surface thereof; and
  - a wire member fabricated of an elastically deformable and elastically recoverable material circumferentially disposed about and adhered to the abluminal surface of the tubular substrate by adhesive means interfacing between the wire member and the tubular substrate.
2. The endoluminal prosthesis according to claim 1, wherein the elastically deformable and elastically recoverable material of the wire member is selected from the group

of materials consisting of shape memory alloys, biocompatible spring steels, biocompatible spring metal alloys, and carbon fibers.

3. The endoluminal prosthesis according to claim 2, wherein the shape memory alloys further comprise nickel-titanium alloys.

4. The endoluminal prosthesis according to claim 2, wherein the wire member further comprises a shape memory alloy which a pre-programmed austenite dimensional state which is substantially the same diametric dimension as the diametric dimension of the tubular-shaped substrate.

5. The endoluminal prosthesis according to claim 1, further comprising a polymeric cladding concentrically surrounding the wire member, the cladding being in intimate contact with and joined to the abluminal surface of the tubular-shaped substrate.

6. The endoluminal prosthesis according to claim 5, wherein the adhesive means further comprises a polymeric covering on the wire member and is selected from the group consisting of polytetrafluoroethylene, polyurethane, polyethylene, polypropylene, polyamide, polyimide, polyesters, polypropylene, polyethylene, polyfluoroethylenes, silicone, fluorinated polyolefins, fluorinated ethylene/propylene copolymer, perfluoroalkoxy fluorocarbon, ethylene/tetrafluoroethylene copolymer, and polyvinylpyrrolidone.

7. The endoluminal prosthesis according to claim 1, wherein the tubular-shaped substrate further comprises a biocompatible material selected from the group consisting of expanded polytetrafluoroethylene, polyethylene, polyethylene terephthalate, polyurethane, and collagen.

8. An endoluminal prosthesis comprising a support wire member joined to a planar expanded polytetrafluoroethylene film member, the support wire member and planar expanded polytetrafluoroethylene film member being helically wound into an open cylindrical configuration with adjacent windings forming overlapping regions of the expanded polytetrafluoroethylene film member bonded to one and other.

9. The endoluminal prosthesis according to claim 8, further comprising a planar polytetrafluoroethylene film member in intimate contact with and monolithically joined to the planar expanded polytetrafluoroethylene film member, the support wire member being intermediate the second planar expanded polytetrafluoroethylene film member and the planar expanded polytetrafluoroethylene film member.

10. The endoluminal prosthesis according to claim 8, further comprising a bonding agent joining the support wire member and the planar expanded polytetrafluoroethylene film member.

11. The endoluminal prosthesis according to claim 9, further comprising an adhesive interlayer interdisposed between the planar polytetrafluoroethylene film member and the planar expanded polytetrafluoroethylene film member.

12. The endoluminal prosthesis according to claim 9, wherein the planar polytetrafluoroethylene film member further comprises expanded polytetrafluoroethylene.

13. The endoluminal prosthesis according to claim 10, wherein the adhesive material is selected from the group consisting of polytetrafluoroethylene, polyurethane, polyethylene, polypropylene, polyamide, polyimide, polyesters, polypropylene, polyethylene, polyfluoroethylenes, silicone, fluorinated polyolefins, fluorinated ethylene/propylene copolymer, perfluoroalkoxy fluorocarbon, ethylene/tetrafluoroethylene copolymer, and polyvinylpyrrolidone.

14. The endoluminal prosthesis according to claim 10, wherein the bonding agent is disposed intermediate the wire member and an abluminal wall surface of polytetrafluoroethylene tubular substrate.

15. The endoluminal prosthesis according to claim 10, wherein the bonding agent further comprises a concentric cladding surrounding the wire member.

16. An endoluminal prosthesis, comprising:

a expanded polytetrafluoroethylene tubular-shaped substrate; and

a wire member fabricated of a shape memory alloy helically wound about and adhered to an abluminal surface of the expanded polytetrafluoroethylene tubular-shaped substrate.

17. The endoluminal prosthesis according to claim 16, wherein the shape memory stent further comprises a nickel-titanium alloy.

18. The endoluminal prosthesis according to claim 17, wherein the nickel-titanium alloy further comprises an alloy consisting essentially of nickel present at about 50 at. %, titanium present at about 50 at. %.

19. The endoluminal prosthesis according to claim 16, wherein the wire member has a pre-programmed austenite dimensional state which is substantially the same diametric dimension as the diametric dimension of the expanded polytetrafluoroethylene tubular-shaped substrate.

20. The endoluminal prosthesis according to claim 16, further comprising a polymeric cladding concentrically surrounding the wire member, the cladding being in intimate contact with and joined to the abluminal surface of the tubular-shaped substrate.

21. The endoluminal prosthesis according to claim 20, wherein the polymeric covering is selected from the group consisting of polytetrafluoroethylene, polyurethane, polyethylene, polypropylene, polyamide, polyimide, polyesters, polypropylene, polyethylene, polyfluoroethylenes, silicone, fluorinated polyolefins, fluorinated ethylene/propylene copolymer, perfluoroalkoxy fluorocarbon, ethylene/tetrafluoroethylene copolymer, and polyvinylpyrrolidone.

22. A method for making an endoluminal prosthesis, comprising the step of wrapping a wire member made of a shape memory alloy about and in intimate bonded contact with an abluminal surface of a seamless expanded polytetrafluoroethylene tubular member.

23. The method for making an endoluminal prosthesis according to claim 22, further comprising the step of providing the wire member with a concentric cladding fabricated of a material capable of bonding to the expanded polytetrafluoroethylene tubular member.

24. The method for making an endoluminal prosthesis according to claim 23, wherein the step of providing the wire member with a concentric cladding further comprises the step of selecting a cladding material from the group consisting of polytetrafluoroethylene, polyurethane, polyethylene, polypropylene, polyamide, polyimide, polyester, polyfluoroethylenes, silicone, fluorinated polyolefin, fluorinated ethylene/propylene copolymer, perfluoroalkoxy fluorocarbon, ethylene/tetrafluoroethylene copolymer, and polyvinylpyrrolidone.

25. The method for making an endoluminal prosthesis according to claim 24, wherein the step of providing the wire member further comprises the steps of co-extruding the wire member with a polytetrafluoroethylene cladding.

26. The method for making an endoluminal prosthesis according to claim 25, further comprising the steps of applying a helical wrapping of polytetrafluoroethylene tape circumferentially about the expanded polytetrafluoroethylene tubular substrate and the wire member co-extruded with the polytetrafluoroethylene cladding and along an entire longitudinal extent of the expanded polytetrafluoroethylene tubular substrate thereby radially and longitudinally securing the expanded polytetrafluoroethylene tubular substrate and sintering the assembly at a temperature above the crystalline melt point of polytetrafluoroethylene and for a period of time sufficient to bond the polytetrafluoroethylene cladding to the expanded polytetrafluoroethylene substrate.

27. The method for making an endoluminal prosthesis according to claim 24, further comprising the step of heating the expanded polytetrafluoroethylene tubular substrate and the concentrically clad wire member to a temperature above the melt point of the bonding agent for a period of time sufficient to mechanically bond the concentrically clad wire member to the abluminal surface of the polytetrafluoroethylene tubular substrate.

28. The use of an intraluminal prosthesis according to claim 1 for bypass of an anatomical conduit.

29. The use of an intraluminal prosthesis according to claim 1 for creating an arterio-venous shunt.

30. The use of an intraluminal prosthesis according to claim 23 for creating a transluminal intrahepatic portosystemic shunt.

31. The use of an intraluminal prosthesis according to claim 1 as an intraluminal support structure for maintaining luminal patency.

32. The use of an intraluminal prosthesis according to claim 25 further comprising the use for restoring luminal patency in an anatomical fluid conduit.

\* \* \* \* \*