

(19) **DANMARK**



Patent- og
Varemærkestyrelsen

(10) **DK/EP 1941645 T3**

(12) **Oversættelse af
europæisk patentskrift**

- (51) Int.Cl.: **H 04 L 1/16 (2006.01)** **H 04 B 1/7103 (2011.01)** **H 04 L 1/00 (2006.01)**
H 04 L 5/00 (2006.01) **H 04 L 27/26 (2006.01)**
- (45) Oversættelsen bekendtgjort den: **2022-07-18**
- (80) Dato for Den Europæiske Patentmyndigheds bekendtgørelse om meddelelse af patentet: **2022-06-15**
- (86) Europæisk ansøgning nr.: **06839573.0**
- (86) Europæisk indleveringsdag: **2006-10-26**
- (87) Den europæiske ansøgnings publiceringsdag: **2008-07-09**
- (86) International ansøgning nr.: **US2006060291**
- (87) Internationalt publikationsnr.: **WO2007051158**
- (30) Prioritet: **2005-10-27 US 260931**
- (84) Designerede stater: **AT BE BG CH CY CZ DE DK EE ES FI FR GB GR HU IE IS IT LI LT LU LV MC NL PL PT RO SE SI SK TR**
- (73) Patenthaver: **QUALCOMM Incorporated, 5775 Morehouse Drive, San Diego, CA 92121, USA**
- (72) Opfinder: **GOROKHOV, Alexei, 12543 El Camino Real, San Diego, California 92130, USA**
DONG, Min, 7154 Schilling Avenue, 34, San Diego, California 92126, USA
- (74) Fuldmægtig i Danmark: **Plougmann Vingtoft A/S, Strandvejen 70, 2900 Hellerup, Danmark**
- (54) Benævnelse: **PUNKTERING AF SIGNALERINGSKANAL I ET TRÅDLØST KOMMUNIKATIONSSYSTEM**
- (56) Fremdragne publikationer:
WO-A-2005/015941
JUNYI LI ET AL: "An integrated approach based on cross-layer optimization - Designing a mobile broadband wireless access network" IEEE SIGNAL PROCESSING MAGAZINE, IEEE SERVICE CENTER, PISCATAWAY, NJ, US, vol. 21, no. 5, September 2004 (2004-09), pages 20-28, XP011118149 ISSN: 1053-5888
JIM TOMCIK , QUALCOMM INCORPORATED: "QFDD Technology Overview Presentation" IEEE 802.20 WORKING GROUP ON MOBILE BROADBAND WIRELESS ACCESS, 28 October 2005 (2005-10-28), pages 1-70, XP002429296 Retrieved from the Internet: URL:http://grouper.ieee.org/groups/802/20/ Contribs/C802.20-05-59.pdf>
SAMSUNG: "ACK/NACK signalling performance", 3GPP DRAFT; R1-040688_ACKNACK_SIGNALING, 3RD GENERATION PARTNERSHIP PROJECT (3GPP), MOBILE COMPETENCE CENTRE ; 650, ROUTE DES LUCIOLES ; F-06921 SOPHIA-ANTIPOLIS CEDEX ; FRANCE , vol. RAN WG1, no. Cannes, France; 20040621 - 20040624 19 June 2004 (2004-06-19), XP050951860, Retrieved from the Internet: URL:http://www.3gpp.org/ftp/tsg_ran/WG1_RL_1/TSGR1_AH/Rel-6_AH_0406/Docs/ZIPs/ [retrieved on 2004-06-19]
QUALCOMM EUROPE: "Compatibility of the enhancements with existing releases", 3GPP DRAFT; R1-040086, 3RD GENERATION PARTNERSHIP PROJECT (3GPP), MOBILE COMPETENCE CENTRE ; 650, ROUTE DES LUCIOLES ; F-06921 SOPHIA-ANTIPOLIS CEDEX ; FRANCE, vol. RAN WG1, no. Espoo, Finland; 20040202, 2

Fortsættes ...

February 2004 (2004-02-02), XP050111997, [retrieved on 2004-02-02]

DESCRIPTION

BACKGROUND

I. Field

[0001] The present invention relates generally to communication, and more specifically to techniques for transmitting signaling in a communication system.

II. Background

[0002] Wireless communication systems are widely deployed to provide various communication services such as voice, packet data, broadcast, messaging, and so on. These systems may be multiple-access systems capable of supporting communication for multiple users by sharing the available system resources. Examples of such multiple-access systems include code division multiple access (CDMA) systems, time division multiple access (TDMA) systems, and frequency division multiple access (FDMA) systems.

[0003] A communication system may employ a transmission scheme with feedback to improve reliability for data transmission. For example, a transmitter may transmit a data packet to a receiver, which may send back an acknowledgment (ACK) if the packet is decoded correctly or a negative acknowledgment (NAK) if the packet is decoded in error. The transmitter uses the ACK to terminate the transmission of the packet and uses the NAK to retransmit all or a portion of the packet. The transmitter is thus able to transmit just enough data for each packet based on the feedback from the receiver.

[0004] A base station in a multiple-access system may concurrently communicate with multiple terminals on the forward and reverse links at any given moment. The forward link (or downlink) refers to the communication link from the base stations to the terminals, and the reverse link (or uplink) refers to the communication link from the terminals to the base stations. The base station may transmit data to multiple terminals on the forward link and may receive ACKs and/or NAKs (or ACK information) from these terminals on the reverse link. The ACK information from the terminals, although beneficial, represent overhead in the system.

[0005] There is therefore a need in the art for techniques to efficiently send ACK information in a communication system.

[0006] Attention is drawn to an article in the IEEE SIGNAL PROCESSING MAGAZINE, Sept. 2014, p. 20-28, , entitled "Designing a Mobile Broadband Wireless Access Network, An integrated approach based on cross-layer optimization" by JUNYI LI ET AL, which is directed to

a new wireless system to enable a broadband mobile wireless access network. This system leverages the standard Internet protocol (IP) network elements to build the system and employs a new air interface technology based on orthogonal frequency division multiplexing (OFDM). 3GPP document R1-40688 "ACK/NACK signalling performance" by Samsung discloses ACK/NACK signaling by puncturing of a downlink traffic channel. 3GPP document R1-040086 "Compatibility of the enhancements with existing releases" by Qualcomm discloses ACK signaling in the uplink by puncturing a traffic channel.

Summary

[0007] In accordance with the present invention a method and apparatus for wireless communications as set forth in the independent claims are provided. Preferred embodiments are described in the dependent claims.

[0008] Techniques for efficiently transmitting signaling in a communication system are described herein. The signaling may be ACK information or some other information. In an embodiment, a signaling channel that punctures traffic channels is used to send signaling. The signaling channel may also be called a control channel, an overhead channel, a feedback channel, and so on. The signaling channel may be mapped to resources, e.g. time-frequency segments, and each traffic channel may be mapped to different resources. Each time-frequency segment and each time-frequency block may be a block of time and frequency. A time-frequency segment and a time-frequency block may have the same or different sizes. The signaling channel punctures the traffic channels in that data is not sent on the traffic channels in the portion of the time-frequency blocks that collide with the time-frequency segments for the signaling channel. Hence, the signaling channel punctures or blanks out the traffic channels whenever collision occurs.

[0009] In an embodiment, signaling is sent with code division multiplexing (CDM) on the signaling channel. At a transmitter (e.g., a terminal), the resources, e.g. time-frequency segments, for the signaling channel are initially determined, e.g., based on a frequency hopping pattern for the signaling channel. Signaling is spread with a spreading code (e.g., a Walsh code) to generate spread signaling, which is then mapped to the resources for the signaling channel. In an embodiment, each resource is partitioned into multiple clusters, and a signaling message is mapped to different clusters in multiple resources to achieve diversity. Traffic data may be mapped to other resources for a traffic channel assigned for use. Traffic data that is mapped to the other resources for the signaling channel is punctured. The mapped signaling and traffic data are further processed (e.g., modulated for OFDM or SC-FDMA) and transmitted.

[0010] In an embodiment, to receive the signaling at a receiver (e.g., a base station), received symbols are extracted from the resources for the signaling channel. The extracted received symbols are despread with the spreading code to obtain despread symbols. The extracted received symbols may also be despread with one or more spreading codes not used for

signaling to obtain interference estimates. The despread symbols are detected (e.g., with the interference estimates, if available) to recover the transmitted signaling. Extracted received symbols from different clusters may be despread and combined to recover a signaling message sent on these clusters. Received symbols may also be extracted from the resources for the assigned traffic channel. Received symbols extracted from the resources for the signaling channel are punctured. The unpunctured received symbols are processed to obtain decoded data.

[0011] Various aspects and embodiments of the invention are described in further detail below.

BRIEF DESCRIPTION OF THE DRAWINGS

[0012] The features and nature of the present invention will become more apparent from the detailed description set forth below when taken in conjunction with the drawings in which like reference characters identify correspondingly throughout.

FIG. 1 shows a wireless communication system.

FIG. 2 illustrates H-ARQ transmission on the forward link.

FIGS. 3A and 3B show two subcarrier structures.

FIG. 4 shows a frequency-hopping scheme.

FIGS. 5A and 5B show two signaling transmission schemes for an ACK channel.

FIG. 6 shows puncturing of a time-frequency block for the ACK channel.

FIG. 7A shows an ACK segment with multiple clusters.

FIG. 7B shows a time-frequency block not punctured by an ACK segment.

FIG. 7C shows a time-frequency block punctured by an ACK segment.

FIG. 8 shows transmission of an ACK message to achieve diversity.

FIG. 9 shows a binary channel tree.

FIG. 10 shows a process for sending signaling and traffic data.

FIG. 11 shows an apparatus for sending signaling and traffic data.

FIG. 12 shows a process for receiving signaling and traffic data.

FIG. 13 shows an apparatus for receiving signaling and traffic data.

FIG. 14 shows a block diagram of a base station and a terminal.

FIG. 15 shows a block diagram of a transmit data and signaling processor.

FIG. 16 shows a block diagram of a receive data and signaling processor.

DETAILED DESCRIPTION

[0013] The word "exemplary" is used herein to mean "serving as an example, instance, or illustration." Any embodiment or design described herein as "exemplary" is not necessarily to be construed as preferred or advantageous over other embodiments or designs.

[0014] FIG. 1 shows a wireless communication system 100 with multiple base stations 110 and multiple terminals 120. A base station is a station that communicates with the terminals. A base station may also be called, and may contain some or all of the functionality of, an access point, a Node B, and/or some other network entity. Each base station 110 provides communication coverage for a particular geographic area 102. The term "cell" can refer to a base station and/or its coverage area depending on the context in which the term is used. To improve system capacity, a base station coverage area may be partitioned into multiple smaller areas, e.g., three smaller areas 104a, 104b, and 104c. Each smaller area is served by a respective base transceiver subsystem (BTS). The term "sector" can refer to a BTS and/or its coverage area depending on the context in which the term is used. For a sectorized cell, the BTSs for all sectors of that cell are typically co-located within the base station for the cell. The signaling transmission techniques described herein may be used for a system with sectorized cells as well as a system with un-sectorized cells. For simplicity, in the following description, the term "base station" is used generically for a station that serves a sector as well as a station that serves a cell.

[0015] Terminals 120 are typically dispersed throughout the system, and each terminal may be fixed or mobile. A terminal may also be called, and may contain some or all of the functionality of, a mobile station, a user equipment, and/or some other device. A terminal may be a wireless device, a cellular phone, a personal digital assistant (PDA), a wireless modem card, and so on. A terminal may communicate with zero, one, or multiple base stations on the forward and reverse links at any given moment.

[0016] For a centralized architecture, a system controller 130 couples to base stations 110 and provides coordination and control for these base stations. System controller 130 may be a single network entity or a collection of network entities. For a distributed architecture, the base stations may communicate with one another as needed.

[0017] The signaling transmission techniques described herein may be used to send various types of signaling such as ACK information, power control commands, channel quality indicators (CQIs), requests for system resources, access probes, feedback information, and so

on. These techniques are used for the reverse link. For clarity, these techniques are described below for sending ACK information on the reverse link.

[0018] System 100 may employ hybrid automatic repeat request (H-ARQ) transmission, which is also called incremental redundancy (IR) transmission. With H-ARQ, a transmitter sends one or more transmissions for a data packet until the packet is decoded correctly by a receiver or the maximum number of transmissions has been sent. H-ARQ improves reliability for data transmission and supports rate adaptation for packets in the presence of changes in channel conditions.

[0019] FIG. 2 illustrates H-ARQ transmission on the forward link. A base station processes (e.g., encodes and modulates) a data packet (Packet 1) and generates multiple (V) data blocks, where $V > 1$. A data packet may also be called a codeword and so on. A data block may also be called a subpacket, an H-ARQ transmission, and so on. Each data block for the packet may contain sufficient information to allow a terminal to correctly decode the packet under favorable channel conditions. The V data blocks typically contain different redundancy information for the packet. Each data block may be sent in a frame, which may be of any time duration. The V data blocks are sent one at a time until the packet is terminated, and the block transmissions are spaced apart by Q frames, where $Q > 1$.

[0020] The base station transmits the first data block (Block 1) for Packet 1 in frame m . The terminal receives and processes (e.g., demodulates and decodes) Block 1, determines that Packet 1 is decoded in error, and sends a NAK to the base station in frame $m + q$, where q is the ACK/NAK delay and $1 \leq q < Q$. The base station receives the NAK and transmits the second data block (Block 2) for Packet 1 in frame $m + Q$. The terminal receives Block 2, processes Blocks 1 and 2, determines that Packet 1 is decoded in error, and sends back a NAK in frame $m + Q + q$. The block transmission and NAK response may continue up to V times. For the example shown in FIG. 2, the base station transmits data block 3 (Block 3) for Packet 1 in frame $m + 2Q$. The terminal receives Block 3, processes Blocks 1 through 3 for Packet 1, determines that the packet is decoded correctly, and sends back an ACK in frame $m + 2Q + q$. The base station receives the ACK and terminates the transmission of Packet 1. The base station processes the next data packet (Packet 2) and transmits the data blocks for Packet 2 in similar manner.

[0021] In FIG. 2, a new data block is sent every Q frames. To improve channel utilization, the base station may transmit up to Q packets in an interlaced manner. In an embodiment, a first interlace is formed with frames $m, m + Q$, and so on, a second interlace is formed with frames $m + 1, m + Q + 1$, and so on, and a Q -th interlace is formed with frames $m + Q - 1, m + 2Q - 1$, and so on. The Q interlaces are offset from one another by one frame. The base station may transmit up to Q packets on the Q interlaces. For example, if $Q = 2$, then the first interlace may include odd-numbered frames, and the second interlace may include even-numbered frames. As another example, if $Q = 6$, then six interlaces may be formed and used to send six packets in an interlaced manner. In general, the H-ARQ retransmission delay Q and the ACK/NAK delay q are typically selected to provide sufficient processing time for both the transmitter and

receiver.

[0022] For clarity, FIG. 2 shows transmission of both NAKs and ACKs. For an ACK-based scheme, which is assumed for the description below, an ACK is sent if a packet is decoded correctly, and NAKs are not sent and are presumed by the absence of ACKs.

[0023] The signaling transmission techniques described herein may be used for various wireless communication systems such as a CDMA system, a TDMA system, an FDMA system, an orthogonal frequency division multiple access (OFDMA) system, a single-carrier frequency division multiple access (SC-FDMA) system, and so on. An OFDMA system utilizes orthogonal frequency division multiplexing (OFDM), which is a modulation technique that partitions the overall system bandwidth into multiple (K) orthogonal subcarriers. These subcarriers are also called tones, bins, and so on. With OFDM, each subcarrier that may be independently modulated with data. An SC-FDMA system may utilize interleaved FDMA (IFDMA) to transmit on subcarriers that are distributed across the system bandwidth, localized FDMA (LFDMA) to transmit on a block of adjacent subcarriers, or enhanced FDMA (EFDMA) to transmit on multiple blocks of adjacent subcarriers. In general, modulation symbols are sent in the frequency domain with OFDM and in the time domain with SC-FDMA.

[0024] The signaling transmission techniques may also be used with various subcarrier structures. For simplicity, the following description assumes that the K total subcarriers are usable for transmission and are given indices of 1 through K .

[0025] FIG. 3A shows a distributed subcarrier structure 300. For subcarrier structure 300, the K total subcarriers are arranged into S non-overlapping sets such that each set contains N subcarriers that are uniformly distributed across the K total subcarriers. Consecutive subcarriers in each set are spaced apart by S subcarriers, where $K = S \cdot N$. Hence, set s contains subcarriers $s, S + s, 2S + s, \dots, (N - 1) \cdot S + s$, for $s \in \{1, \dots, S\}$.

[0026] FIG. 3B shows a block subcarrier structure 310. For subcarrier structure 310, the K total subcarriers are arranged into S non-overlapping sets such that each set contains N consecutive subcarriers, where $K = S \cdot N$. Hence, set s contains subcarriers $(s - 1) \cdot N + 1$ through $s \cdot N$, for $s \in \{1, \dots, S\}$.

[0027] In general, the signaling transmission techniques may be used with any subcarrier structure having any number of subcarrier sets. Each subcarrier set may include any number of subcarriers that may be arranged in any manner. For example, the subcarriers in each set may be uniformly distributed across the system bandwidth as shown in FIG. 3A, contiguous as shown in FIG. 3B, and so on. The subcarrier sets may include the same or different numbers of subcarriers.

[0028] FIG. 4 shows an exemplary partitioning of time and frequency into time-frequency blocks. A time-frequency block may also be called a tile, a traffic block, or some other terminology. In an embodiment, a time-frequency block corresponds to a specific subcarrier set

in a specific time interval, which may span one or multiple symbol periods. A symbol period is the duration of one OFDM symbol or one SC-FDMA symbol. S orthogonal time-frequency blocks are available in each time interval.

[0029] System 100 may define traffic channels to facilitate allocation and use of the available system resources. A traffic channel is a means for sending data from a transmitter to a receiver and may also be called a channel, a physical channel, a physical layer channel, a data channel, a transmission channel, and so on. Traffic channels may be defined for various types of system resources such as frequency and time.

[0030] In general, any number of traffic channels may be defined, and the traffic channels may have the same or different transmission capacities. For simplicity, much of the following description assumes that S traffic channels are defined, with each traffic channel being mapped to one time-frequency block in each time interval used for data transmission. These S traffic channels may be assigned to up to S terminals.

[0031] FIG. 4 also shows an exemplary frequency-hopping scheme 400. For scheme 400, each traffic channel is mapped to a specific sequence of time-frequency blocks that hop across frequency in different time intervals to achieve frequency diversity, as shown in FIG. 4. A hop interval is the amount of time spent on a given sub carrier set and is equal to one time interval for the embodiment shown in FIG. 4. A frequency hopping (FH) pattern indicates the specific time-frequency block to use for each traffic channel in each time interval used for data transmission. FIG. 4 shows the sequence of time-frequency blocks for traffic channel y . The other traffic channels may be mapped to vertically and circularly shifted versions of the time-frequency block sequence for traffic channel y .

[0032] Frequency hopping may be used with the subcarrier structures shown in FIGS. 3A and 3B. In an embodiment, which is called symbol rate hopping, a time-frequency block is one distributed subcarrier set (e.g., as shown in FIG. 3A) in one symbol period. For symbol rate hopping, the subcarriers for a traffic channel span across the entire system bandwidth and change from symbol period to symbol period. In another embodiment, which is called block hopping, a time-frequency block is one contiguous subcarrier set (e.g., as shown in FIG. 3B) in multiple symbol periods. For block hopping, the subcarriers for a traffic channel are contiguous and fixed for an entire hop interval but change from hop interval to hop interval. Other frequency hopping schemes may also be defined.

[0033] A terminal may send ACK information on a reverse link acknowledgment channel (R-ACKCH) to a base station to acknowledge H-ARQ transmissions sent by the base station on the forward link. The R-ACKCH is also called an ACK channel in the following description. Referring back to FIG. 2, an H-ARQ transmission is sent in one frame, which may span one or multiple hop intervals. The terminal may send an ACK/NAK for each frame in which an H-ARQ transmission is received from the base station. Several embodiments of the ACK channel for different frame sizes are described below.

[0034] FIG. 5A shows a signaling transmission scheme 500 for the ACK channel. For the embodiment shown in FIG. 5A, a frame spans two hop intervals, and the ACK channel is mapped to one time-frequency block in each ACK frame. An ACK frame is a frame in which the ACK channel is sent, and a data frame is a frame used for data transmission. Each data frame may be associated with an ACK frame that is q frames away, as shown in FIG. 2. The ACK channel may puncture all or a portion of each time-frequency block to which the ACK channel is mapped, as described below.

[0035] FIG. 5B shows a signaling transmission scheme 510 for the ACK channel. For the embodiment shown in FIG. 5B, $S = 32$, a frame spans one hop interval, and the ACK channel is mapped to four time-frequency blocks in each ACK frame. The ACK channel may puncture all or a portion of each time-frequency block.

[0036] For clarity, FIGS. 5A and 5B show the ACK channel puncturing one traffic channel y whenever the ACK channel is mapped to a time-frequency block used for traffic channel y . The ACK channel also punctures other traffic channels, which are not labeled in FIGS. 5A and 5B for clarity. A terminal may transmit data on an assigned traffic channel (e.g., traffic channel y) and may transmit ACK messages on the ACK channel. If many traffic channels are available, then the ACK channel punctures only a portion of the transmission on the assigned traffic channel and punctures mostly the transmissions from other terminals on other traffic channels.

[0037] In general, the ACK channel may be mapped to any number of time-frequency blocks in each ACK frame. In an embodiment, the ACK channel is mapped to a fixed number of time-frequency blocks in each ACK frame. This fixed number may be determined based on the number of available traffic channels and/or some other factors. In another embodiment, the ACK channel is mapped to a configurable number of time-frequency blocks in each ACK frame. This configurable number may be determined based on the number of traffic channels that are in use, the number of packets that are sent on each traffic channel, the number of ACK bits that may be sent in each time-frequency block, and so on.

[0038] FIGS. 5A and 5B show specific embodiments for puncturing the traffic channels with the ACK channel. In another embodiment, the ACK channel is mapped to one or more fixed subcarrier sets, and the traffic channels hop around the fixed ACK channel. In yet another embodiment, the S subcarrier sets are arranged into G regions, with each region including S/G consecutive subcarrier sets. The ACK channel is then mapped to one subcarrier set in each region. The ACK channel may also puncture the traffic channels in other manners.

[0039] In general, the ACK channel may be mapped to time-frequency blocks in a pseudo-random or deterministic manner. The ACK channel may be mapped to different subcarrier sets to achieve frequency and interference diversity, e.g., as shown in FIGS. 5A and 5B. In an embodiment, the ACK channel is pseudo-random with respect to the traffic channels and equally punctures the traffic channels. This may be achieved by hopping the ACK channel, hopping the traffic channels, or hopping both the ACK channel and the traffic channels. An FH pattern may indicate the specific time-frequency block(s) for the ACK channel in each ACK

frame. This FH pattern may be sent to the terminals or may be known *a priori* by the terminals. In any case, the terminals have knowledge of the time-frequency blocks occupied by the ACK channel.

[0040] FIG. 6 shows an embodiment of the puncturing of a time-frequency block by the ACK channel. The time-frequency block covers N subcarriers and spans T symbol periods. In general, the ACK channel may puncture all or a portion of the time-frequency block. An ACK segment is a time-frequency segment used for the ACK channel. An ACK segment is formed by the part of the time-frequency block that is punctured and used for the ACK channel. In general, an ACK segment may cover any number of subcarriers and may span any number of symbol periods. In an embodiment, which is not shown in FIG. 6, the ACK channel punctures the entire time-frequency block. For this embodiment, the ACK channel is sent in the entire time-frequency block, and traffic data is not sent in the time-frequency block. In another embodiment, which is shown in FIG. 6, the ACK channel punctures a portion of the time-frequency block. For example, the ACK channel may puncture a half, a quarter, an eighth, or some other fraction of the time-frequency block. The punctured portion may be contiguous in both time and frequency, as shown in FIG. 6. Transmission on contiguous subcarriers may result in a lower peak-to-average power ratio (PAPR), which is desirable. Alternatively, the punctured portion may be spread across frequency, across time, or across both frequency and time. In any case, the ACK channel is sent in the punctured portion of the time-frequency block, and traffic data may be sent in the remaining portion of the time-frequency block.

[0041] FIG. 7A shows an embodiment of an ACK segment. For this embodiment, the ACK segment covers 8 subcarriers and spans 8 symbol periods. The ACK segment includes 64 transmission units. A transmission unit is one subcarrier in one symbol period. For the embodiment shown in FIG. 7A, the ACK segment is partitioned into four clusters. Each cluster covers 8 subcarriers, spans 2 consecutive symbol periods, and includes 16 transmission units.

[0042] In general, an ACK segment may be partitioned in various manners. In another embodiment, each cluster covers two subcarriers and spans all 8 symbol periods. In yet another embodiment, each cluster covers all subcarriers and spans all symbol periods in the ACK segment. For example, cluster 1 may include subcarriers 1 and 2 in symbol periods 1 and 5, subcarriers 3 and 4 in symbol periods 2 and 6, subcarriers 5 and 6 in symbol periods 3 and 7, and subcarriers 7 and 8 in symbol periods 4 and 8.

[0043] FIG. 7B shows an embodiment of a time-frequency block that is not punctured by an ACK segment. For this embodiment, the time-frequency block covers 16 subcarriers, spans 8 symbol periods, and includes 128 transmission units. Pilot symbols may be sent on some of the transmission units, and data symbols may be sent on the remaining transmission units. As used herein, a data symbol is a symbol for traffic data, a pilot symbol is a symbol for pilot, which is data that is known *a priori* by both the base station and the terminals, a signaling symbol is a symbol for signaling, and a symbol is typically a complex value. For the embodiment shown in FIG. 7B, pilot symbols are sent on subcarriers 1, 9 and 16 in symbol periods 1, 2, 3, 6, 7 and 8, or six strips of three pilot symbols. The pilot symbols may be

distributed across frequency, e.g., as shown in FIG. 7B, and may be used to derive a channel estimate for the time-frequency block. The channel estimate may be used to perform data detection for the data symbols sent in the time-frequency block.

[0044] FIG. 7C shows an embodiment of a time-frequency block that is punctured by an ACK segment. For this embodiment, pilot symbols are sent on subcarriers 9 and 16 in symbol periods 1, 2, 3, 6, 7 and 8, or four strips of three pilot symbols. The pilot symbols may be used to derive a channel estimate for the unpunctured portion of the time-frequency block.

[0045] The embodiment shown in FIGS. 7B and 7C allows a serving sector to derive an interference estimate for an ACK segment for one or more neighbor sectors. A terminal may transmit on an entire time-frequency block to the serving sector if this time-frequency block is not punctured by an ACK segment for the serving sector. However, this time-frequency block may collide with an ACK segment for one or more neighbor sectors. In this case, the lower half of the time-frequency block may observe higher interference from the ACK segment for the neighbor sector(s). The serving sector may estimate the interference from the other sector(s) based on the pilot symbols sent on subcarrier 1 in symbol periods 1, 2, 3, 6, 7 and 8. The serving sector may use the interference estimate for data detection of the data symbols sent in the time-frequency block.

[0046] FIGS. 7B and 7C show one embodiment for sending pilot and data in a time-frequency block. Pilot and data may also be sent using various other patterns for a time-frequency block. In general, a sufficient number of pilot symbols may be sent on a time-frequency block to allow a serving sector to derive a channel estimate for the time-frequency block, with and without puncturing by an ACK segment for the serving sector. A sufficient number of pilot symbols may be located such that the serving sector can derive an interference estimate for the ACK segment from neighbor sectors.

[0047] A terminal may send an ACK message for each H-ARQ transmission received from a base station. The amount of information sent in each ACK message may be dependent on the number of packets sent in the corresponding H-ARQ transmission. In an embodiment, an ACK message includes one bit that acknowledges an H-ARQ transmission for one packet. In another embodiment, an ACK message includes multiple (B) bits that acknowledge an H-ARQ transmission for B packets. In an embodiment, an ACK message is sent with On/Off keying, for example, '1' for ACK and '0' for NAK. In another embodiment, an ACK message is encoded prior to transmission.

[0048] Multiple terminals may send their ACK messages using code division multiplexing (CDM), time division multiplexing (TDM), frequency division multiplexing (FDM), some other orthogonal multiplexing scheme, or a combination thereof. Multiple terminals may send their ACK messages in the same cluster of an ACK segment using any orthogonal multiplexing scheme.

[0049] In an embodiment, ACK messages are sent using CDM. For this embodiment, the

terminals are assigned different spreading codes or sequences, and each terminal spread its ACK messages with its spreading code. The spread ACK messages for the terminals are orthogonal to one another in the code domain.

[0050] In an embodiment, the spreading codes are orthogonal codes formed with columns of a Hadamard matrix. A 2×2 Hadamard matrix $\underline{W}_{2 \times 2}$ and a larger size Hadamard matrix $\underline{W}_{2L \times 2L}$ may be expressed as:

$$\underline{W}_{2 \times 2} = \begin{bmatrix} 1 & 1 \\ 1 & -1 \end{bmatrix} \quad \text{and} \quad \underline{W}_{2L \times 2L} = \begin{bmatrix} \underline{W}_{L \times L} & \underline{W}_{L \times L} \\ \underline{W}_{L \times L} & -\underline{W}_{L \times L} \end{bmatrix}. \quad \text{Eq (1)}$$

Hadamard matrices of square dimensions that are power of two (e.g., 2×2 , 4×4 , 8×8 , and so on) may be formed as shown in equation (1).

[0051] In another embodiment, the spreading codes are orthogonal codes formed with columns of a Fourier matrix. An $L \times L$ Fourier matrix $\underline{F}_{L \times L}$ has element $f_{n,m}$ in the n -th row of the m -th column, which may be expressed as:

$$f_{n,m} = e^{j2\pi \frac{(n-1)(m-1)}{L}}, \quad \text{for } n=1, \dots, L \text{ and } m=1, \dots, L. \quad \text{Eq (2)}$$

Fourier matrices of any square dimension (e.g., 2×2 , 3×3 , 4×4 , 5×5 , and so on) may be formed as shown in equation (2).

[0052] A 1-bit ACK message may be spread with an L -chip spreading code to generate a spread ACK message that contains L chips, as follows:

$$x_{u,i} = a_u \cdot w_{u,i}, \quad \text{for } i=1, \dots, L, \quad \text{Eq (3)}$$

where a_u is an ACK bit for terminal u , which may have a value of 0 or 1, or $a_u \in \{0, 1\}$;

$w_{u,i}$ is the i -th chip of the spreading code assigned to terminal u ; and

$X_{u,i}$ is the i -th chip of the spread ACK message for terminal u .

The L chips of the spread ACK message may be sent in the frequency domain by mapping these L ACK chips to L transmission units in an ACK segment, e.g., like OFDMA. Alternatively, these L ACK chips may be sent in the time domain by performing an L -point DFT/FFT to obtain L frequency-domain symbols and mapping these L symbols to L transmission units in an ACK segment, e.g., like SC-FDMA.

[0053] For the embodiment shown in FIG. 7A, a 1-bit ACK message may be sent in 16 transmission units, and the ACK bit may be spread with a 16-chip spreading code to generate 16 ACK chips. These 16 ACK chips may then be mapped to 16 transmission units in one ACK cluster. Up to 15 other terminals may send their ACK messages in the same cluster using other spreading codes. Up to 64 terminals may send ACK messages in one ACK segment.

[0054] In an embodiment, a subset of the available spreading codes is used for sending ACK information. The remaining spreading codes are not used for sending ACK information and are used instead for interference estimation. In an embodiment, each cluster includes 16

transmission units (e.g., as shown in FIG. 7A), eight spreading codes may be used to send ACK information and are called usable spreading codes, and the remaining eight spreading codes are used for interference estimation and are called reserved spreading codes. For this embodiment, eight usable spreading codes are available for each cluster, and up to 32 ACK messages may be sent in one ACK segment. For this embodiment, eight reserved spreading codes may be used for interference estimation in each cluster. More than 32 ACK messages may be sent in one ACK segment by allocating more spreading codes for sending ACK messages. More than 32 ACK messages may be sent in one ACK frame by allocating more ACK segments for the ACK channel.

[0055] In another embodiment, ACK messages are sent using TDM or FDM. For this embodiment, the terminals are assigned different transmission units for the ACK channel, and each terminal sends its ACK message in its assigned transmission units. The ACK messages for the terminals would then be orthogonal to one another in time and/or frequency. In an embodiment based on the ACK segment shown in FIG. 7A, eight terminals may be assigned eight rows of a cluster, and each terminal may send its ACK bit on the two transmission units in the assigned row. In another embodiment, four clusters are formed, with each cluster covering two subcarriers and spanning 8 symbol periods. Eight terminals may be assigned eight columns of a cluster, and each terminal may send its ACK bit on the two transmission units in the assigned column.

[0056] FIG. 8 shows an embodiment for transmitting an ACK message to achieve frequency and time diversity. For this embodiment, the ACK message is sent on different clusters in multiple (C) ACK segments, one cluster in each ACK segment. For the embodiment shown in FIG. 8, $C = 4$, and the ACK message is sent on four different clusters in four ACK segments to achieve time diversity. Sending the ACK message over a longer time interval may also improve link budget for terminals located at the edge of coverage. These disadvantage terminals typically have an upper limit on transmit power. A longer transmission time interval for the ACK message allows a disadvantage terminal to transmit the ACK message with more energy spread over a longer period of time, which improves the likelihood of correctly receiving the ACK message. The ACK message also achieves frequency diversity since the four ACK segments occupy different subcarrier sets in different 2-symbol intervals. C-th order diversity may be achieved for the ACK message by sending the ACK message in different clusters in C ACK segments.

[0057] In an embodiment, an ACK message is sent on different clusters in C ACK segments, and the terminals are mapped to the clusters in a pseudo-random or deterministic manner such that an ACK message for each terminal observes interference from a different set of terminals in each of the C clusters on which that ACK message is sent. This embodiment provides time and frequency diversity for the ACK message sent by each terminal. This embodiment further provides diversity with respect to the interference from the other terminals.

[0058] A base station performs the complementary despreading to recover the ACK messages sent by the terminals. For each terminal u , the base station despreads the received symbols

from each of the C clusters used by terminal u with the spreading code assigned to terminal u and obtains C despread symbols for the C clusters. For each of the C clusters, the base station may also despread the received symbols with each of the reserved spreading codes to obtain an interference estimate for that cluster. The base station may then scale and combine the C despread symbols for terminal u with the interference estimates for the C clusters to obtain a detected ACK message for terminal u , as described below.

[0059] The signaling transmission techniques described herein may be used with various channel structures. An exemplary channel structure is described below.

[0060] FIG. 9 shows an embodiment of a binary channel tree 900. For the embodiment shown in FIG. 9, $S = 32$ subcarrier sets are available for use. A set of traffic channels may be defined with the 32 subcarrier sets. Each traffic channel is assigned a unique channel ID and is mapped to one or more subcarrier sets in each time interval. For example, a traffic channel may be defined for each node in channel tree 900. The traffic channels may be sequentially numbered from top to bottom and from left to right for each tier. The largest traffic channel corresponding to the topmost node is assigned a channel ID of 0 and is mapped to all 32 subcarrier sets. The 32 traffic channels in the lowest tier 1 have channel IDs of 31 through 62 and are called base traffic channels. Each base traffic channel is mapped to one subcarrier set.

[0061] The tree structure shown in FIG. 9 places certain restrictions on the use of the traffic channels for an orthogonal system. For each traffic channel that is assigned, all traffic channels that are subsets (or descendants) of the assigned traffic channel and all traffic channels for which the assigned traffic channel is a subset are restricted. The restricted traffic channels are not used concurrently with the assigned traffic channel so that no two traffic channels use the same subcarrier set at the same time.

[0062] In an embodiment, an ACK resource is assigned to each traffic channel that is assigned for use. An ACK resource may also be called an ACK sub-channel or some other terminology. An ACK resource includes pertinent resources (e.g., a spreading code and a set of clusters) used to send an ACK message in each ACK frame. For this embodiment, the ACK messages for each traffic channel may be sent on the assigned ACK resource. The assigned ACK resources may be signaled to the terminal.

[0063] In another embodiment, an ACK resource is associated with each of the base traffic channels in the lowest tier of a channel tree. This embodiment allows for assignment of the maximum number of traffic channels of the minimum size. A larger traffic channel corresponding to a node above the lowest tier may use (1) the ACK resources for all base traffic channels under the larger traffic channel, (2) the ACK resource for one of the base traffic channels, e.g., the base traffic channel with the lowest channel ID, or (3) the ACK resources for a subset of the base traffic channels under the larger traffic channel. For options (1) and (3) above, an ACK message for the larger traffic channel may be sent using multiple ACK resources to improve the likelihood of correct reception. If multiple packets are sent in parallel,

e.g., using multiple-input multiple-output (MIMO) transmission, then a larger traffic channel with multiple base traffic channels may be assigned for the transmission. The number of base traffic channels is equal to or greater than the number of packets. Each packet may be mapped to a different base traffic channel. The ACK for each packet may then be sent using the ACK resource for the associated base traffic channel.

[0064] In yet another embodiment, an ACK resource is assigned to each packet to be acknowledged. A terminal may be assigned one ACK resource if one packet is sent in a frame. A terminal may be assigned multiple ACK resources if multiple packets are sent in a frame, e.g., using either a larger traffic channel or spatial multiplexing to transmit via multiple antennas.

[0065] In yet another embodiment, an H-ARQ transmission may span multiple interlaces, and an ACK message is sent in multiple ACK frames. The base station may combine the detected ACK messages for the multiple ACK frames to improve ACK detection performance.

[0066] System 100 may support a single-carrier mode and a multi-carrier mode. In the single-carrier mode, K subcarriers may be available for transmission, and the ACK channel may puncture the traffic channels as described above. In the multi-carrier mode, K subcarriers may be available for each of multiple carriers. The ACK channel may be scaled up for the multi-carrier mode to support more traffic channels and/or to acknowledge more packets that may be sent with more carriers.

[0067] The transmit power for the ACK channel may be controlled to achieve good performance, which may be quantified by a given target ACK-to-NAK error rate (e.g., 1%), a given target NAK-to-ACK error rate (e.g., 0.1%), and/or some other metrics. In an embodiment, the transmit power for the ACK channel for a given terminal is adjusted based on the measured performance for the ACK channel for that terminal. In another embodiment, the transmit power for the ACK channel is adjusted based on the transmit power for a reference channel. The reference channel may be any channel that is sent often or regularly, e.g., a traffic channel or a signaling channel such as a channel quality indicator (CQI) channel. The ACK channel may use the transmit power for the reference channel as a power reference. The transmit power for the ACK channel may be set equal to the power reference plus a delta, which may be adjusted based on the performance of the ACK channel. The reference channel is thus used for short-term power set point while the long-term offset of the ACK channel is controlled based on the ACK performance.

[0068] FIG. 10 shows an embodiment of a process 1000 for sending signaling and traffic data. The signaling may be ACK messages or some other type of signaling. Process 1000 may be performed by a terminal to transmit on the reverse link.

[0069] For the embodiment shown in FIG. 10, signaling is sent with CDM. The time-frequency segments for a signaling channel that punctures traffic channels are determined, e.g., based on a frequency hopping pattern for the signaling channel (block 1012). Signaling is generated

(block 1014) and spread with a spreading code (e.g., a Walsh code) to obtain spread signaling (block 1016). The spread signaling is mapped to the time-frequency segments for the signaling channel (block 1018). Each time-frequency segment may include multiple clusters. A signaling message may be mapped to different clusters in multiple time-frequency segments to achieve diversity. The signaling may also be sent with other multiplexing schemes instead of CDM.

[0070] Traffic data is processed and mapped to time-frequency blocks for a traffic channel assigned for use (block 1022). Traffic data that is mapped to the time-frequency segments for the signaling channel is punctured (block 1024). OFDM symbols or SC-FDMA symbols are generated for the mapped signaling and traffic data (block 1026).

[0071] FIG. 11 shows an embodiment of an apparatus 1100 for sending signaling and traffic data. Apparatus 1100 includes means for determining time-frequency segments for a signaling channel that punctures traffic channels (block 1112), means for generating signaling (block 1114), means for spreading the signaling with a spreading code (e.g., a Walsh code) to generate spread signaling (block 1116), and means for mapping the spread signaling to the time-frequency segments for the signaling channel (block 1118). A signaling message may be mapped to different clusters in multiple time-frequency segments to achieve diversity. Apparatus 1110 further includes means for processing and mapping traffic data to time-frequency blocks for an assigned traffic channel (block 1122), means for puncturing traffic data that is mapped to the time-frequency segments for the signaling channel (block 1124), and means for generating OFDM symbols or SC-FDMA symbols for the mapped signaling and traffic data (block 1126).

[0072] FIG. 12 shows an embodiment of a process 1200 for receiving signaling and traffic data. Process 1200 may be performed by a base station to receive signaling and data sent on the reverse link. The time-frequency segments for the signaling channel are determined (block 1212). Received symbols are extracted from the time-frequency segments for the signaling channel (block 1214). The extracted received symbols are processed to recover the transmitted signaling. For the embodiment shown in FIG. 12, the extracted received symbols are despread with a spreading code assigned to a terminal to obtain despread symbols for the terminal (block 1216). The extracted received symbols may also be despread with spreading code(s) not used for signaling to obtain interference estimates (block 1218). The despread symbols are detected (e.g., with the interference estimates, if available) to recover the signaling sent by the terminal (block 1220). A signaling message may be sent on different clusters in multiple time-frequency segments. In this case, received symbols are extracted from each cluster and despread with the spreading code, and the despread symbols for the different clusters are detected to recover the signaling message.

[0073] Received symbols are extracted from time-frequency blocks for a traffic channel assigned to the terminal (block 1222). Received symbols extracted from the time-frequency segments for the signaling channel are punctured (block 1224). The unpunctured received symbols are processed to obtain decoded data for the terminal (block 1226).

[0074] FIG. 13 shows an embodiment of an apparatus 1300 for receiving signaling and traffic data. Apparatus 1300 includes means for determining the time-frequency segments for the signaling channel (block 1312), means for extracting received symbols from the time-frequency segments for the signaling channel (block 1314), means for despreading the extracted received symbols with a spreading code assigned to a terminal to obtain despread symbols (block 1316), means for despreading the extracted received symbols with spreading code(s) not used for signaling to obtain interference estimates (block 1318), and means for performing detection on the despread symbols (e.g., with the interference estimates, if available) to recover the signaling sent by the terminal (block 1320). A signaling message may also be recovered from different clusters in multiple time-frequency segments. Apparatus 1300 further includes means for extracting received symbols from time-frequency blocks for a traffic channel assigned to the terminal (block 1322), means for puncturing received symbols extracted from the time-frequency segments for the signaling channel (block 1324), and means for processing the unpunctured received symbols to obtain decoded data for the terminal (block 1326).

[0075] FIG. 14 shows a block diagram of an embodiment of a base station 110 and a terminal 120 in FIG. 1. For this embodiment, base station 110 and terminal 120 are each equipped with a single antenna.

[0076] At base station 110, a transmit (TX) data and signaling processor 1410 receives traffic data for one or more terminals, processes (e.g., formats, encodes, interleaves, and symbol maps) the traffic data for each terminal based on one or more coding and modulation schemes selected for that terminal, and provides data symbols. Processor 1410 also generates pilot symbols and signaling symbols. An OFDM modulator 1412 performs OFDM modulation on the data symbols, pilot symbols, and signaling symbols and provides OFDM symbols. If system 100 utilizes SC-FDMA, then modulator 1412 performs SC-FDMA modulation and provides SC-FDMA symbols. A transmitter (TMTR) 1414 conditions (e.g., converts to analog, filters, amplifies, and upconverts) the OFDM symbols to generate an FL modulated signal, which is transmitted from an antenna 1416.

[0077] At terminal 120, an antenna 1452 receives FL modulated signals from base station 110 and possibly other base stations and provides a received signal to a receiver (RCVR) 1454. Receiver 1454 processes (e.g., conditions and digitizes) the received signal and provides received samples. An OFDM demodulator (Demod) 1456 performs OFDM demodulation on the received samples and provides received symbols for the K total subcarriers. A receive (RX) data and signaling processor 1458 processes (e.g., symbol demaps, deinterleaves, and decodes) the received symbols and provides decoded data and signaling for terminal 120.

[0078] A controller/processor 1470 receives decoding results from processor 1458 and generates ACK messages for terminal 120. A TX data and signaling processor 1460 generates signaling symbols for the ACK messages, data symbols for traffic data to be sent to base station 110, and pilot symbols. An OFDM modulator 1462 performs OFDM modulation on the data symbols, pilot symbols, and signaling symbols and provides OFDM symbols. A transmitter

1464 conditions the OFDM symbols and generates an RL modulated signal, which is transmitted from antenna 1452.

[0079] At base station 110, RL modulated signals from terminal 120 and other terminals are received by antenna 1416, conditioned and digitized by a receiver 1420, demodulated by an OFDM demodulator 1422, and processed by an RX data and signaling processor 1424 to recover the ACK messages and traffic data sent by terminal 120 and other terminals. A controller/processor 1430 receives the detected ACK messages and controls the data transmissions on the forward link to the terminals.

[0080] Controllers/processors 1430 and 1470 direct the operation of various processing units at base station 110 and terminal 120, respectively. Memories 1432 and 1472 store program codes and data for base station 110 and terminal 120, respectively.

[0081] FIG. 15 shows a block diagram of an embodiment of TX data and signaling processor 1460 at terminal 120. Processor 1460 includes a TX data processor 1510, a TX signaling processor 1520, and a multiplexer (MUX)/combiner 1530.

[0082] Within TX data processor 1510, a unit 1512 encodes, interleaves, and symbol maps traffic data and provides data symbols. A symbol-to-subcarrier mapper 1514 maps the data symbols to the time-frequency blocks for a traffic channel assigned to terminal 120. A puncturer 1516 punctures data symbols that are mapped to time-frequency segments for the ACK channel and provides the unpunctured data symbols.

[0083] Within TX signaling processor 1520, a data spreader 1522 spreads an ACK message with a spreading code assigned to terminal 120 and provides ACK chips. For the embodiment shown in FIG. 15, the spreading is performed in the frequency domain, and data spreader 1522 provides the ACK chips as signaling symbols. In another embodiment, which is not shown in FIG. 15, the spreading is performed in the time domain, and a DFT unit transforms the ACK chips for each symbol period to the frequency domain and provides the signaling symbols. For both embodiments, a symbol-to-subcarrier mapper 1524 maps the signaling symbols to the proper clusters in the time-frequency segments for the ACK channel. Unit 1530 combines the data symbols from processor 1510 and the signaling symbols from processor 1520 and provides the mapped data and signaling symbols.

[0084] FIG. 16 shows a block diagram of an embodiment of RX data and signaling processor 1424 at base station 110. Processor 1424 includes an RX data processor 1610 and an RX signaling processor 1620. For clarity, the processing to recover traffic data and signaling from one terminal u (e.g., terminal 120 in FIGS. 14 and 15) is described below.

[0085] Within RX data processor 1610, a symbol-to-subcarrier demapper 1612 extracts received symbols from the time-frequency blocks for the traffic channel assigned to terminal 120. A puncturer 1614 punctures the received symbols extracted from the time-frequency segments for the ACK channel and provides the unpunctured received symbols. A unit 1616

symbol demaps, deinterleaves, and decodes the unpunctured received symbols and provides decoded data for terminal 120.

[0086] Within RX signaling processor 1620, a symbol-to-subcarrier demapper 1622 extracts received symbols from the time-frequency segments for the ACK channel. If the spreading is performed in the frequency domain, then an IDFT unit transforms the received symbols for each symbol period to the time domain and provides time-domain samples for despreading (not shown in FIG. 16). If the spreading is performed in the frequency domain, which is shown in FIG. 16 and assumed for the description below, then demapper 1622 provides the received symbols for despreading. A data despreaders 1624 despreads the received symbols from each cluster with the spreading code assigned to terminal 120, as follows:

$$z_{u,c} = \sum_i r_{c,i} \cdot w_{u,i} , \quad \text{Eq (4)}$$

where $r_{c,i}$ is the i -th received symbol from cluster c ; and $z_{u,c}$ is a despread symbol from cluster c for terminal u .

[0087] An interference estimator 1626 despreads the received symbols from each cluster with each reserved spreading code as follows:

$$z_{j,c} = \sum_i r_{c,i} \cdot w_{j,i} , \quad \text{for } j \in \text{RC} \quad \text{Eq (5)}$$

where $z_{j,c}$ is a despread symbol for reserved spreading code j ; and RC is a set of all reserved spreading codes.

[0088] Interference estimator 1626 then derives an interference estimate for each cluster by summing the squared magnitude of the despread symbols for the reserved spreading codes, as follows:

$$I_{0,c} = \sum_{j \in \text{RC}} |z_{j,c}|^2 , \quad \text{Eq (6)}$$

where $I_{0,c}$ is the interference estimate for cluster c .

[0089] A detector 1628 performs detection for the ACK message sent by terminal 120 based on the despread symbols and the interference estimates for all clusters, as follows:

$$A_u = \sum_c \frac{|z_{u,c}|^2}{I_{0,c}} , \quad \text{and} \quad \text{Eq (7)}$$

$$\text{ACK}_u = \begin{cases} '1' & A_u > A_{th} , \\ '0' & \text{otherwise} , \end{cases} \quad \text{Eq (8)}$$

where A_{th} is a threshold used for detecting an ACK bit and ACK_u is the detected ACK message for terminal 120. Equation (7) computes the energy of the despread symbol for the ACK bit for each cluster, scales the symbol energy for each cluster based on the interference estimate for that cluster, and combines the weighted results for all clusters used to send the ACK bit.

[0090] The ACK detection may also be performed in other manners. In another embodiment, base station 110 performs ACK detection with interference cancellation. For example, base station 110 may detect the ACK bit for the strongest received terminal, estimate the

interference due to this terminal, subtract the estimated interference from the received symbols, and detect the ACK bit for the next strongest received terminal based on the interference-canceled received symbols. In yet another embodiment, base station 110 performs coherent ACK detection. For this embodiment, base station 110 derives a channel estimate for each terminal based on a pilot sent by that terminal and performs ACK detection with the channel estimate.

[0091] The signaling transmission techniques described herein may be implemented by various means. For example, these techniques may be implemented in hardware, firmware, software, or a combination thereof. For a hardware implementation, the processing units at a terminal may be implemented within one or more application specific integrated circuits (ASICs), digital signal processors (DSPs), digital signal processing devices (DSPDs), programmable logic devices (PLDs), field programmable gate arrays (FPGAs), processors, controllers, micro-controllers, microprocessors, electronic devices, other electronic units designed to perform the functions described herein, or a combination thereof. The processing units at a base station may also be implemented within one or more ASIC, DSPs, processors, and so on.

[0092] For a firmware and/or software implementation, the techniques may be implemented with modules (e.g., procedures, functions, and so on) that perform the functions described herein. The software codes may be stored in a memory (e.g., memory 1432 or 1472 in FIG. 14) and executed by a processor (e.g., processor 1430 or 1470). The memory may be implemented within the processor or external to the processor.

[0093] It should be noted that the concept of channels herein refers to information or transmission types that may be transmitted by the access point or access terminal. It does not require or utilize fixed or predetermined blocks of subcarriers, time periods, or other resources dedicated to such transmissions.

[0094] Further, time-frequency segments are exemplary resources that may be assigned for signaling and data. The time-frequency segments may also comprise frequency subcarriers, transmission symbols, or other resources, in addition to time frequency segments.

[0095] The previous description of the disclosed embodiments is provided to enable any person skilled in the art to make or use the present invention.

REFERENCES CITED IN THE DESCRIPTION

Cited references

This list of references cited by the applicant is for the reader's convenience only. It does not form part of the European patent document. Even though great care has been taken in compiling the references, errors or omissions cannot be excluded and the EPO disclaims all liability in this regard.

Non-patent literature cited in the description

- **JUNYI LI** Designing a Mobile Broadband Wireless Access Network, An integrated approach based on cross-layer optimization IEEE SIGNAL PROCESSING MAGAZINE, 2014, 20-28 [0006]
- **SAMSUNG** ACK/NACK signalling performance 3GPP document R1-40688, [0006]
- **QUALCOMM** Compatibility of the enhancements with existing releases 3GPP document R1-040086, [0006]

Patentkrav

1. Fremgangsmåde implementeret af en terminal, hvilken fremgangsmåde omfatter:
 - 5 generering (1014) af signalering til afsendelse via en reverse-link-kommunikationskanal; og
 - afbildning af signaleringen til ressourcer for en reverse-link-signaleringskanal, som skjuler trafikkanaler, således at data ikke sendes på trafikkanalerne, når det kolliderer med reverse-link-signaleringskanalen, hvor de skjulte trafikkanaler omfatter trafikkanaler tildelt terminalen og
 - 10 andre terminaler.

2. Fremgangsmåden ifølge krav 1, yderligere omfattende: spredning (1016) af signaleringen med en spredningskode, og hvor den spredte signalering afbildes til ressourcerne for reverse-link-signaleringskanalen.
- 15
3. Fremgangsmåden ifølge krav 1, hvor afbildning af signaleringen til ressourcerne omfatter afbildning af en signaleringsmeddelelse til multiple tids-frekvenssegmenter.

- 20 4. Terminalapparat omfattende:
 - organ (1114) til generering af signalering til afsendelse via en reverse-link-kommunikationskanal; og
 - organ (1118) til afbildning af signaleringen til ressourcer for en reverse-link-signaleringskanal, som skjuler trafikkanalerne, således at data ikke
 - 25 sendes på trafikkanalerne, når det kolliderer med reverse-link-signaleringskanalen,
 - hvor de skjulte trafikkanaler omfatter trafikkanaler tildelt terminalen og andre terminaler.

- 30 5. Apparatet ifølge krav 4, hvor signaleringen omfatter anerkendelser af modtagne dataafsendelser.

6. Apparatet ifølge krav 4, yderligere omfattende organ (1112) til bestemmelse af ressourcerne til reverse-link-signaleringskanalen baseret på et frekvens-hopping-

mønster.

7. Apparatet ifølge krav 4, hvor organerne til afbildning af signaleringen afbilder ressourcerne for reverse-link-signaleringskanalen pseudo-tilfældigt i forhold til 5 trafikkanalerne.

8. Apparatet ifølge krav 4, hvor reverse-link-signaleringskanalen tilsvarende skjuler trafikkanalerne.

10 **9.** Apparatet ifølge krav 4, hvor trafikkanalerne er defineret af et binært kanaltræ, og hvor hver knude i det binære kanaltræ er associeret med specifikke ressourcer i reverse-link-signaleringskanalen.

10. Apparatet ifølge krav 4, hvor hver trafikkanal er associeret med en specifik 15 spredningskode og specifikke ressourcer i reverse-link-signaleringskanalen.

11. Apparatet ifølge krav 4, yderligere omfattende: organ (1116) til spredning af signaleringen med en spredningskode, og hvor den spredte signalering afbildes til ressourcerne for reverse-link-signaleringskanalen.

20

12. Apparatet ifølge krav 11, hvor spredningskoden er afledt af en Hadamard-matrix eller en Fourier-matrix.

13. Apparatet ifølge krav 4, hvor organet (1118) til afbildning af signaleringen til 25 ressourcerne for reverse-link-signaleringskanalen omfatter organ til afbildning af en signaleringsmeddelelse til ressourcer omfattende multiple tidsfrekvens-segmenter.

14. Apparatet ifølge krav 13, hvor signaleringsmeddelelsen observerer interferens 30 fra et andet sæt af sendere i hvert af de multiple tidsfrekvenssegmenter.

15. Apparatet ifølge krav 13, hvor de multiple tidsfrekvenssegmenter dækker forskellige frekvens-subbærebølger.

35

16. Apparatet ifølge krav 4, yderligere omfattende:

organ (1122) til afbildning af data til tidsfrekvensblokke for en trafikkanal;
og

5 organ (1124) til skjulning således at data afbildet til tidsfrekvens-
segmenterne ikke sendes på trafikkanaler, når det kolliderer med reverse-
link-signaleringskanalen.

17. Fremgangsmåde omfattende:

fremgangsmåden ifølge krav 1 og yderligere omfattende:

10 ekstraktion (1214), med en basisstation, af modtagne symboler fra tids-
frekvenssegmenter for reverse-link-signaleringskanalen
bearbejdning (1226), med basisstationen, af de ekstraherede modtagne
symboler for at gendanne signalering sendt på reverse-link-
signaleringskanalen.

15

18. Fremgangsmåden ifølge krav 17, hvor bearbejdningen (1226) af de
ekstraherede modtagne symboler omfatter ikke-spredning (1216) af de
ekstraherede modtagne symboler med en spredningskode for at opnå ikke-
spredte symboler, og udførelse (1120) af detektering på de ikke-spredte symboler
20 for at gendanne signaleringen sendt på reverse-link-signaleringskanalen.

19. Fremgangsmåden ifølge krav 17, hvor bearbejdningen af de ekstraherede
modtagne symboler omfatter ikke-spredning (1218) af de ekstraherede modtagne
symboler med en spredningskode for at opnå ikke-spredte symboler, ikke-
25 spredning af de ekstraherede modtagne symboler med mindst en spredningskode,
som ikke er anvendt til signalering for at opnå interferensestimater, og udførelse
af detektering på ikke-spredte symboler med interferensestimaterne for at
gendanne signaleringen sendt på reverse-link-signaleringskanalen.

30 **20.** Fremgangsmåden ifølge krav 17, yderligere omfattende:

ekstraktion (1222) af modtagne symboler fra ressourcer omfattende tids-
frekvensblokke for en trafikkanal, skjulning af de modtagne symboler ekstraheret
fra ressourcer omfattende tidsfrekvenssegmenter for reverse-link-
signaleringskanalen, og bearbejdning af modtagne ikke-skjulte symboler for at

opnå afkodede data for trafikkanalen.

21. System omfattende:

terminalapparatet ifølge krav 4 og et basisstationsapparat omfattende:

- 5 organ (1314) til at ekstrahere modtagne symboler fra ressourcer for reverse-link-signaleringskanalen og organ til bearbejdning (1326) af de ekstraherede modtagne symboler for at gendanne signalering sendt på reverse-link-signaleringskanalen.

- 10 **22.** Systemet ifølge krav 21, hvor organet (1326) til at bearbejde de ekstraherede modtagne symboler omfatter organ til ikke-spredning af de ekstraherede modtagne symboler med en spredningskode for at opnå ikke-spredte symboler, og organ til at udføre detektering på de ikke-spredte symboler for at gendanne signaleringen sendt på reverse-link-signaleringskanalen.

15

- 23.** Systemet ifølge krav 22, hvor spredningskoden ikke anvendes til signalering for at opnå interferenseestimer.

- 24.** Systemet ifølge krav 21, hvor organet til bearbejdning af de ekstraherede modtagne symboler omfatter organ (1316) til ikke-spredning af de ekstraherede modtagne symboler med en spredningskode for at opnå ikke-spredte symboler, organ (1318) til ikke-spredning af de ekstraherede modtagne symboler med mindst en spredningskode, som ikke anvendes til signalering for at opnå interferenseestimer, og organ (1320) til at udføre detektering på de ikke-spredte symboler med interferenseestimerne for at gendanne signaleringen sendt på reverse-link-signaleringskanalen.

- 25.** Systemet ifølge krav 21, yderligere omfattende: organ (1322) til at ekstrahere modtagne symboler fra ressourcer omfattende tidsfrekvensblokke for en trafikkanal, organ til skjule modtagne symboler ekstraheret fra ressourcerne omfattende tidsfrekvenssegmenter for reverse-link-signaleringskanalen, og organ til bearbejdning af ikke-skjulte symboler for at opnå afkodet data for trafikkanalen.

26. Systemet ifølge krav 21, yderligere omfattende organ til at tildele spredningskoder til terminaler for at sende signalering på reverse-link-signaleringskanalen, og hvor mindst en spredningskode er reserveret til interferensestimering.

DRAWINGS

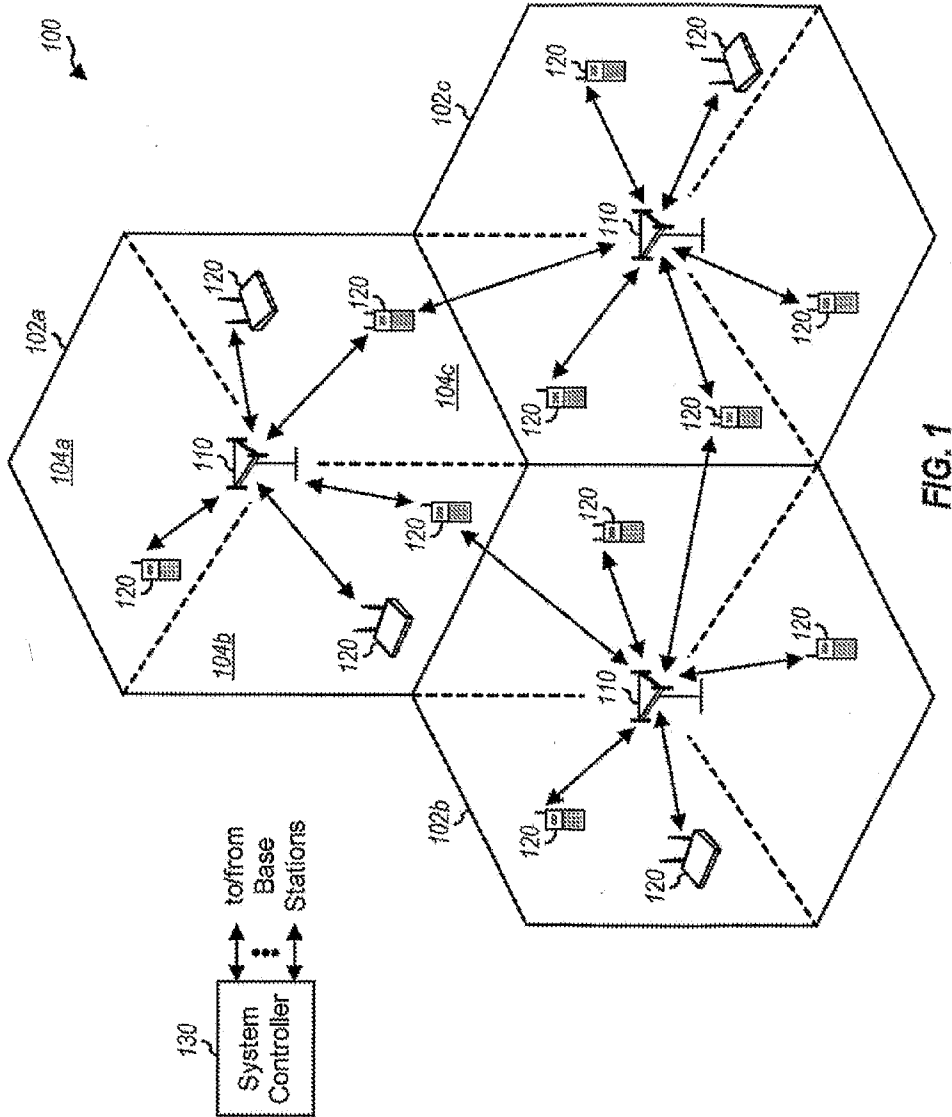

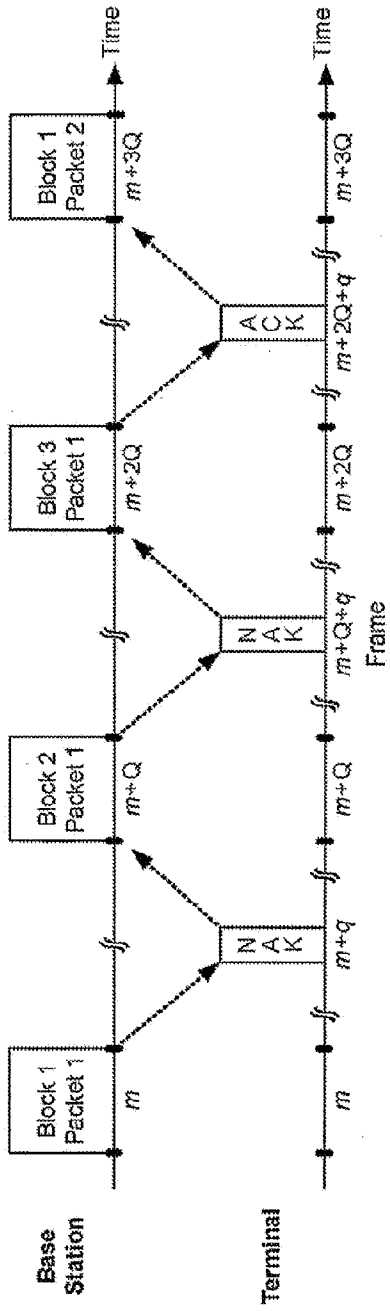

FIG. 2

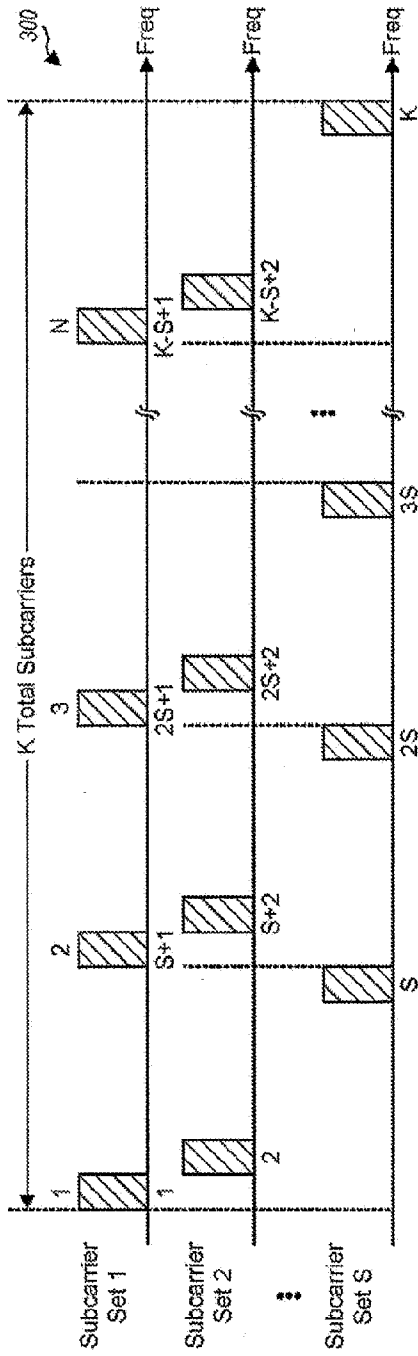

FIG. 3A

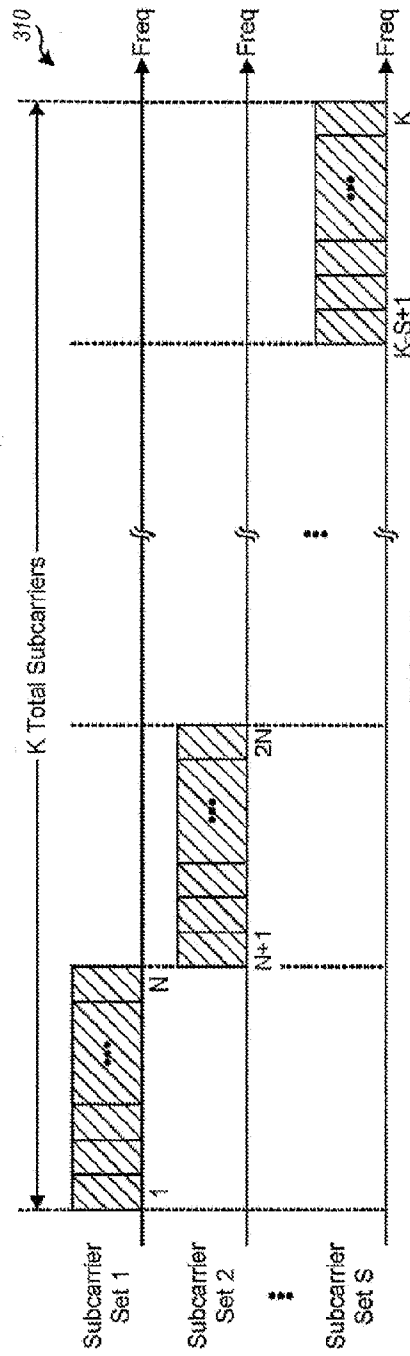

FIG. 3B

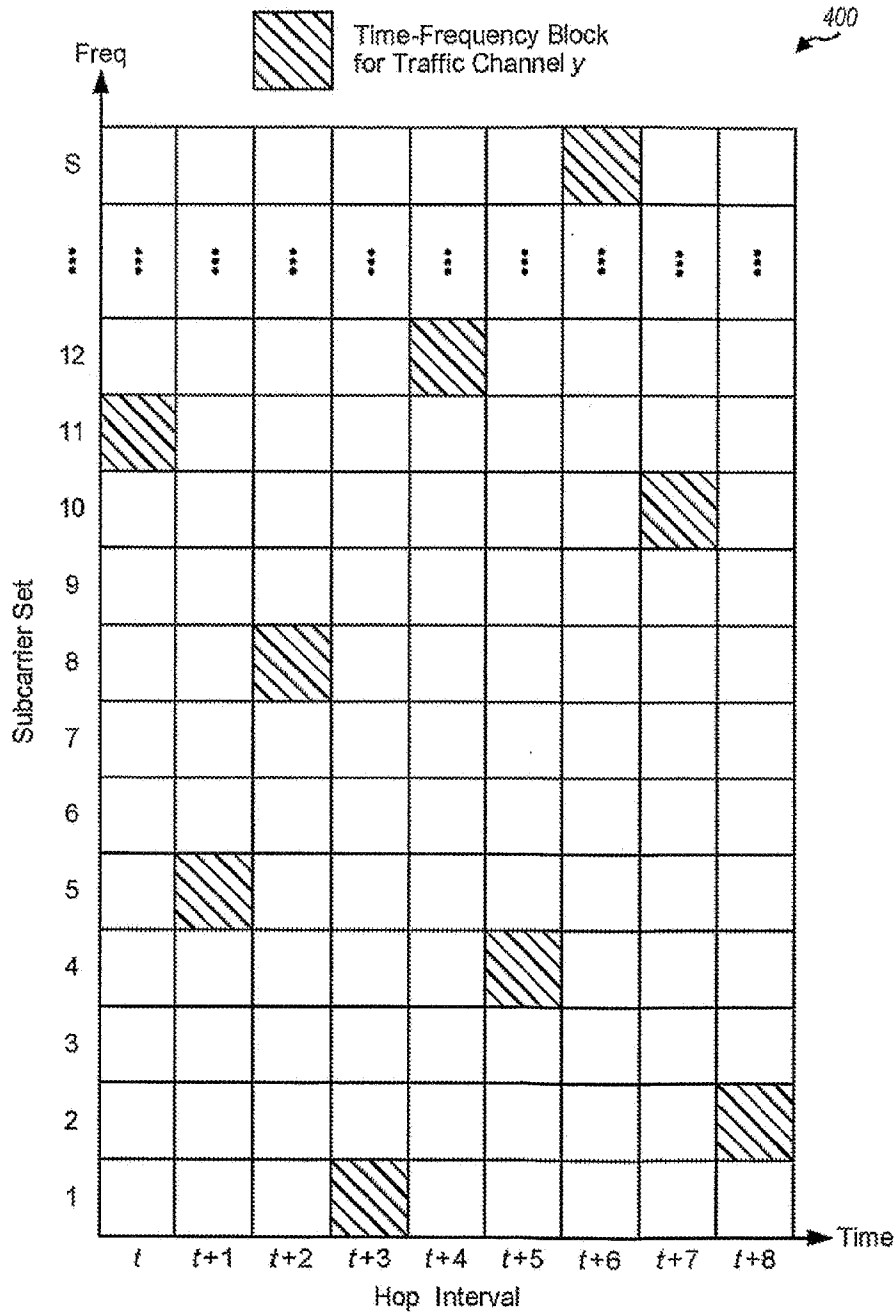

FIG. 4

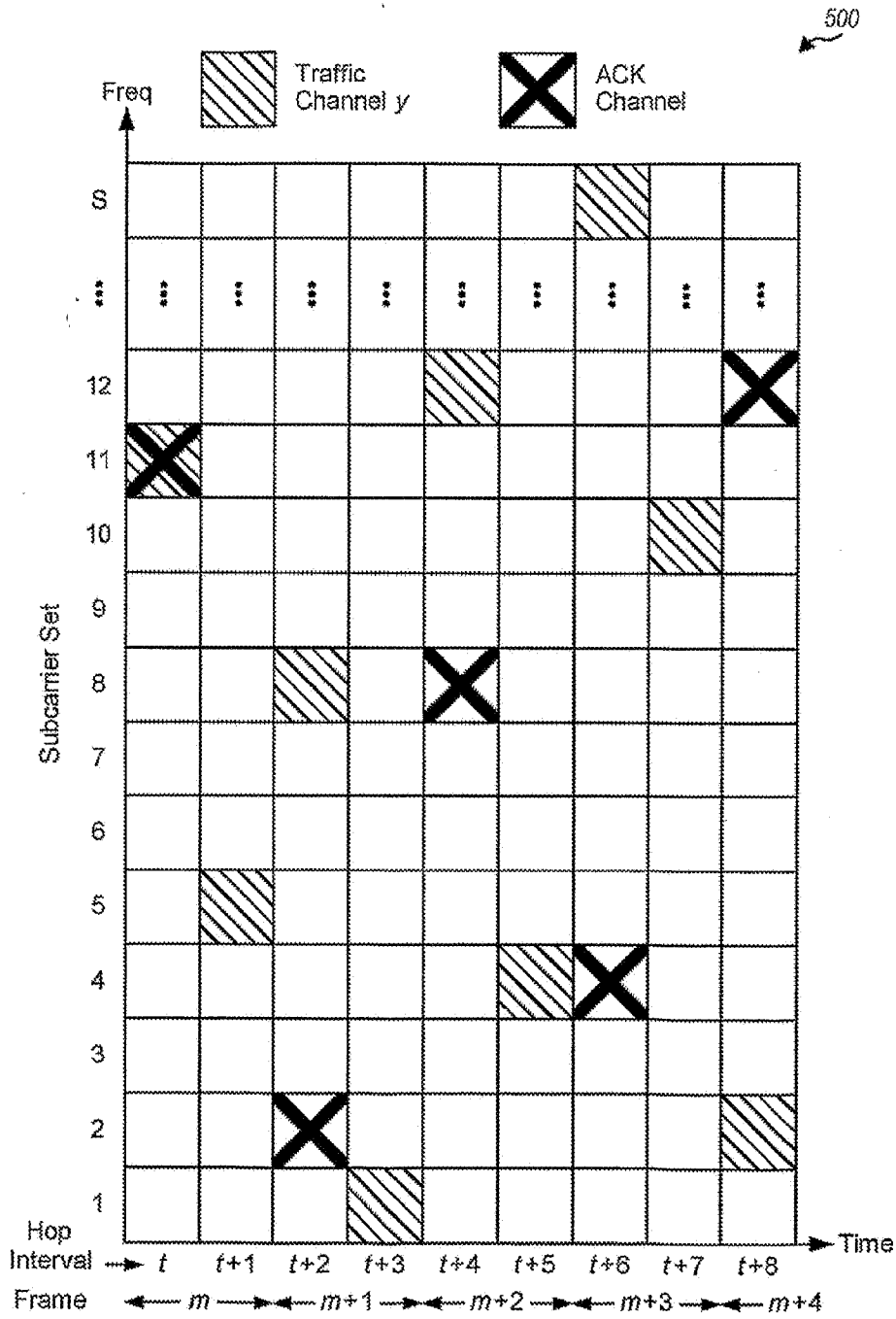

FIG. 5A

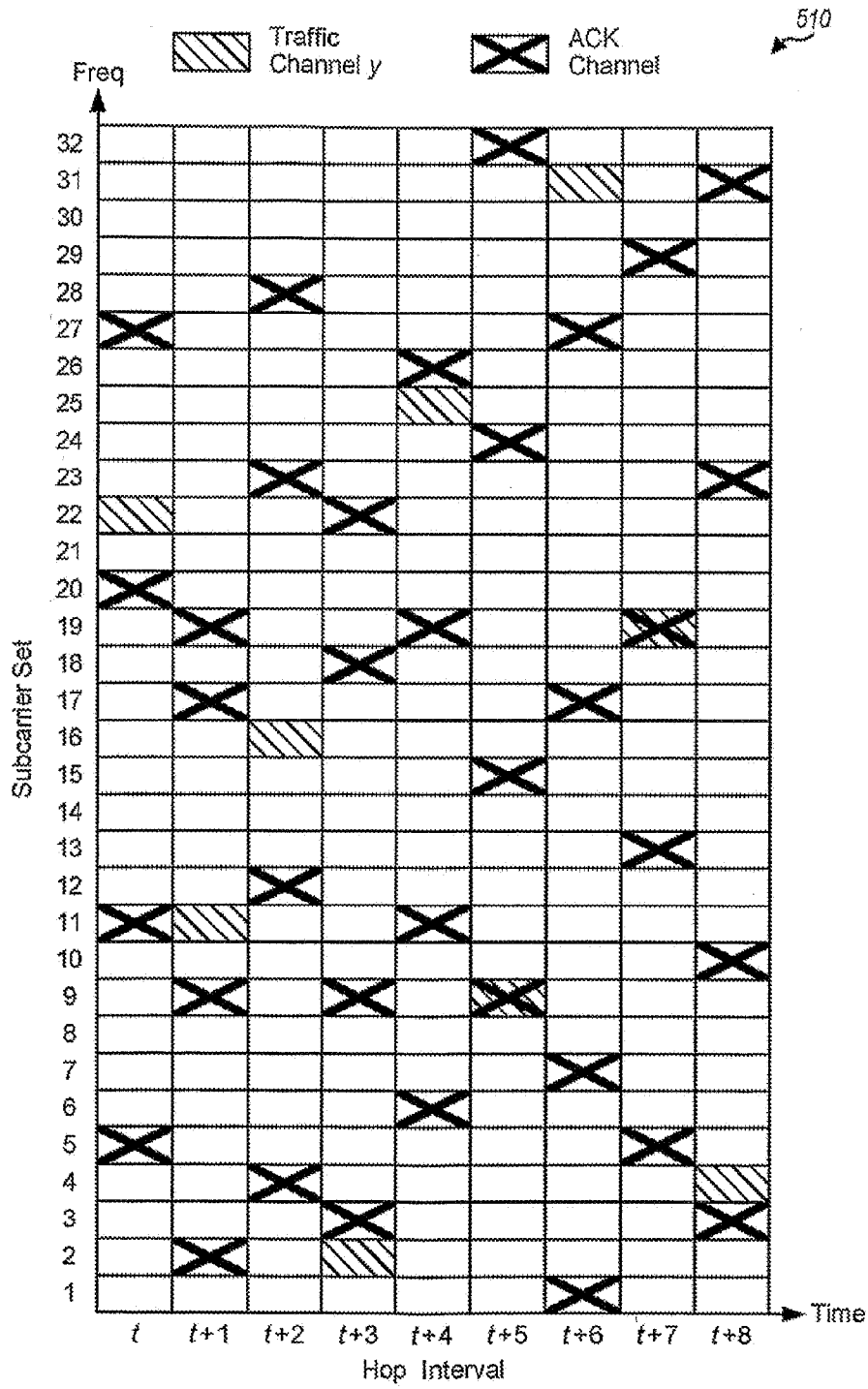

FIG. 5B

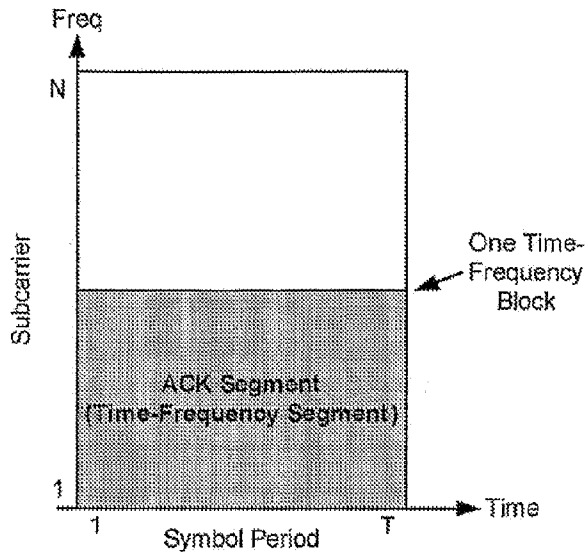

FIG. 6

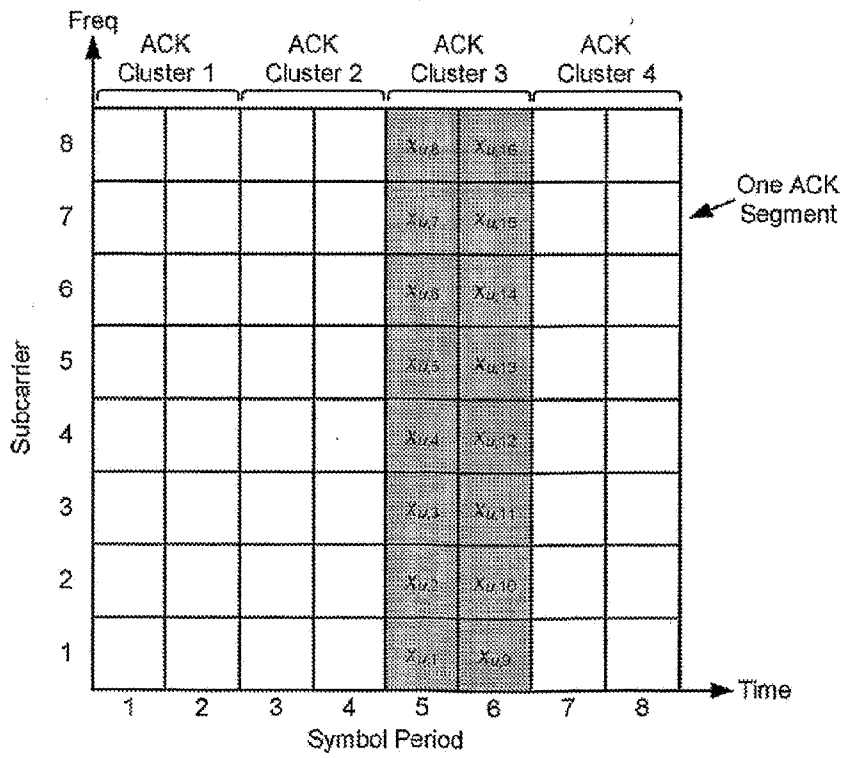

FIG. 7A

One Time-Frequency Block
(not punctured by an ACK segment)

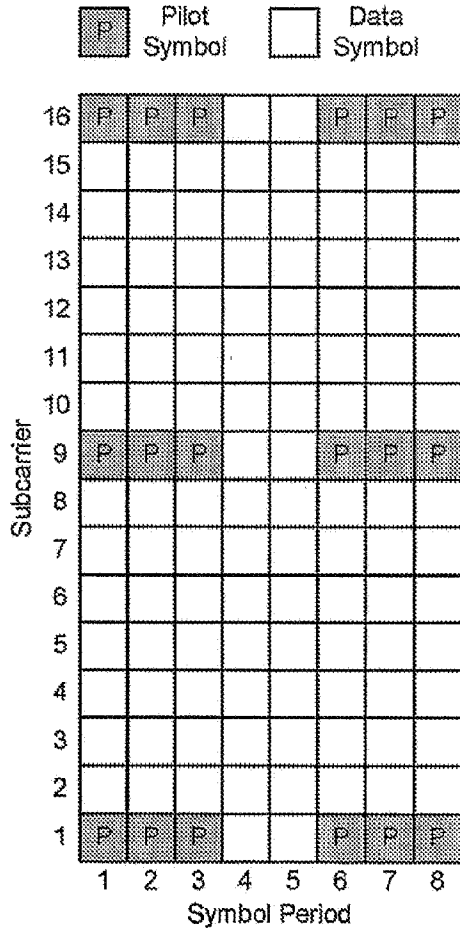

FIG. 7B

One Time-Frequency Block
(punctured by an ACK segment)

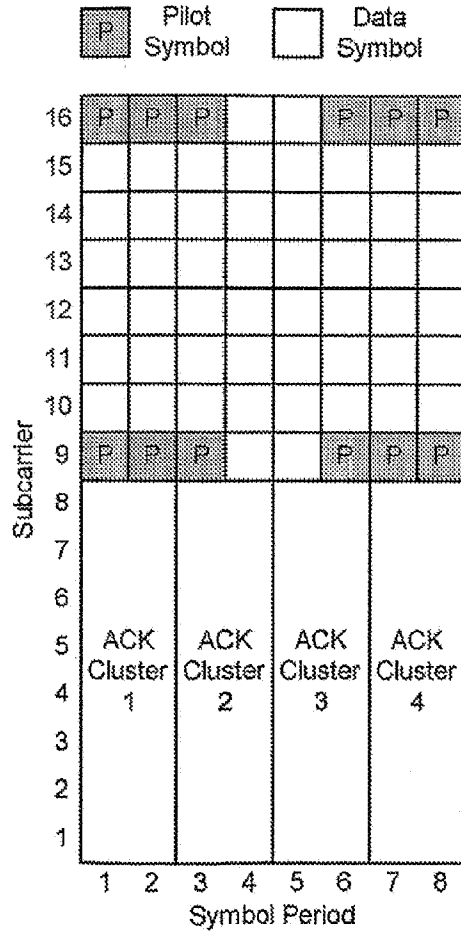

FIG. 7C

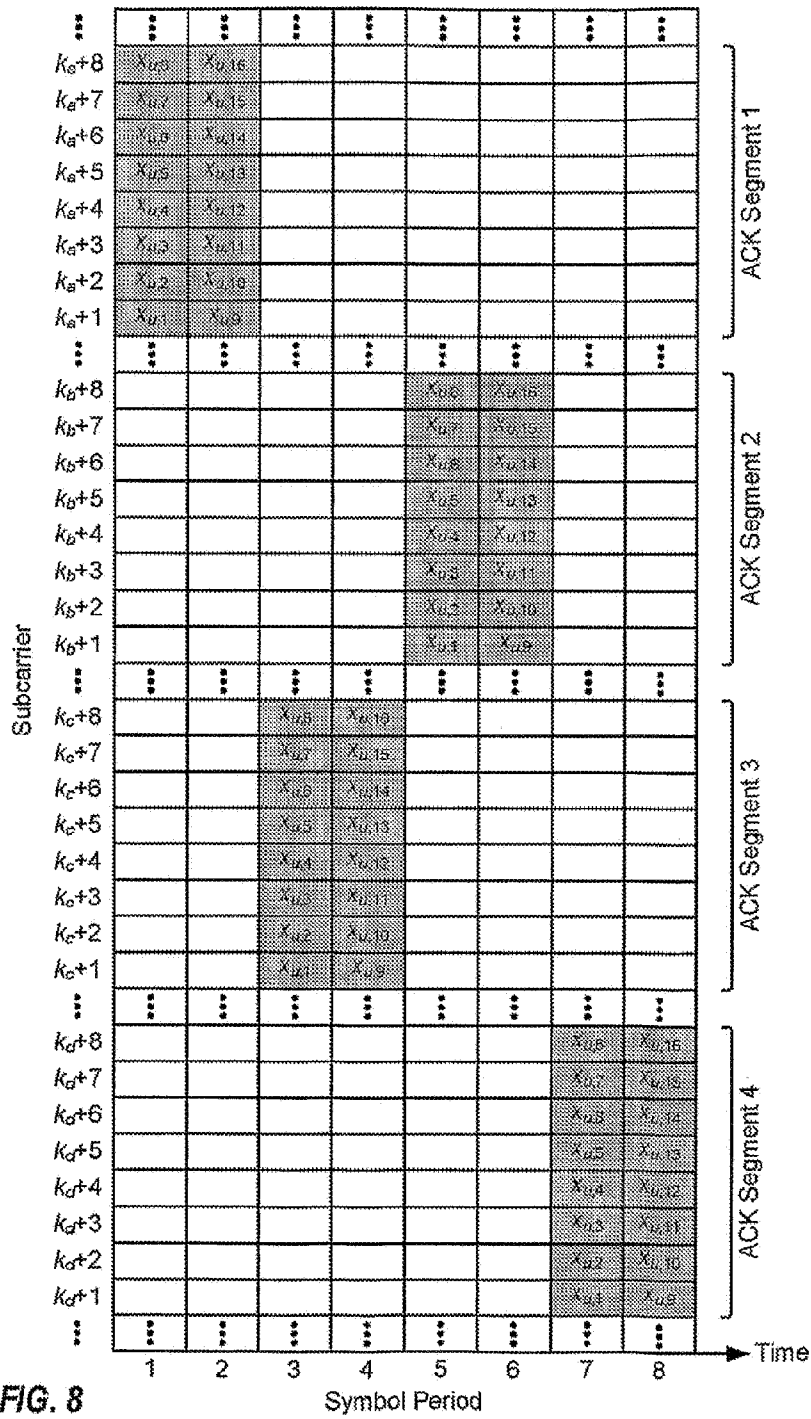

FIG. 8

Symbol Period

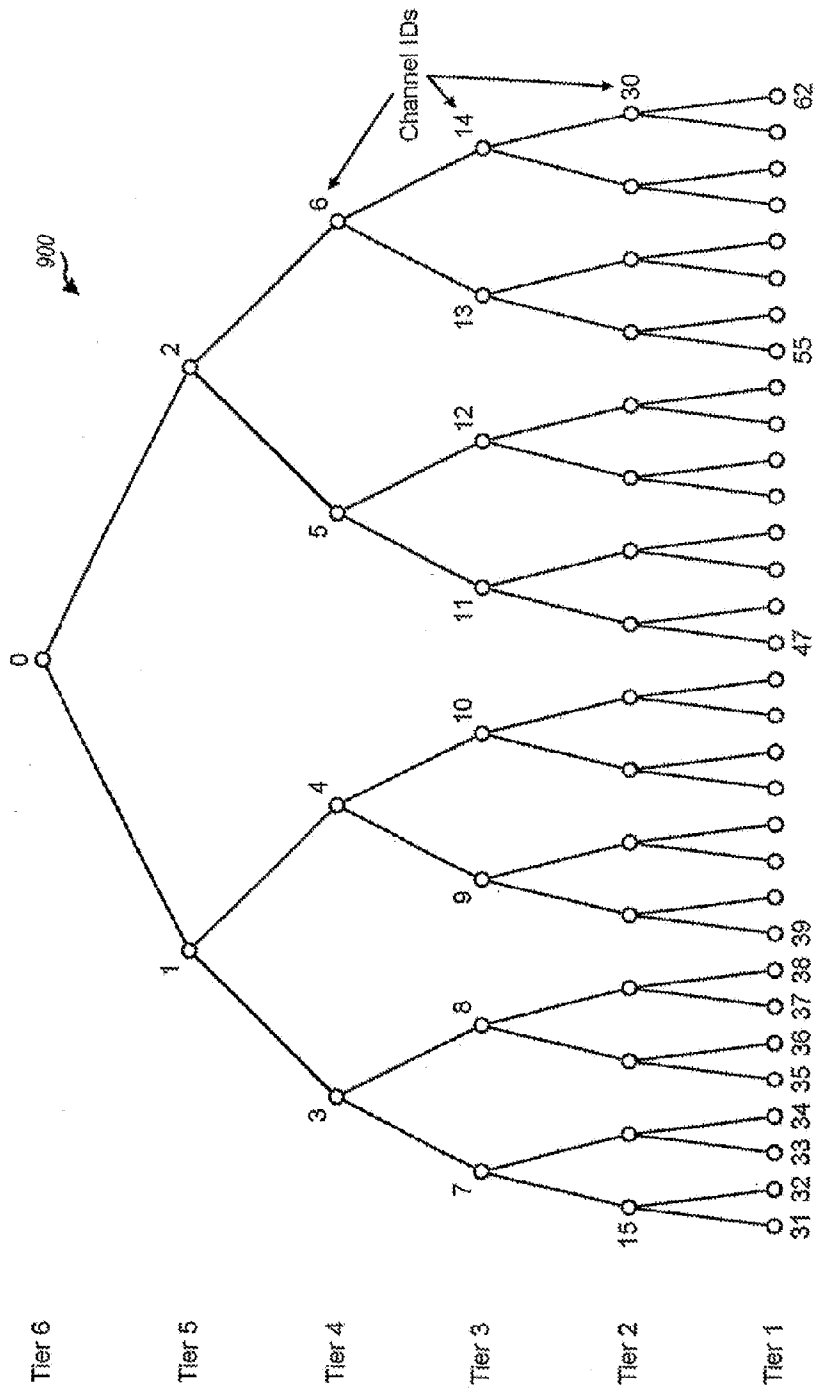

FIG. 9

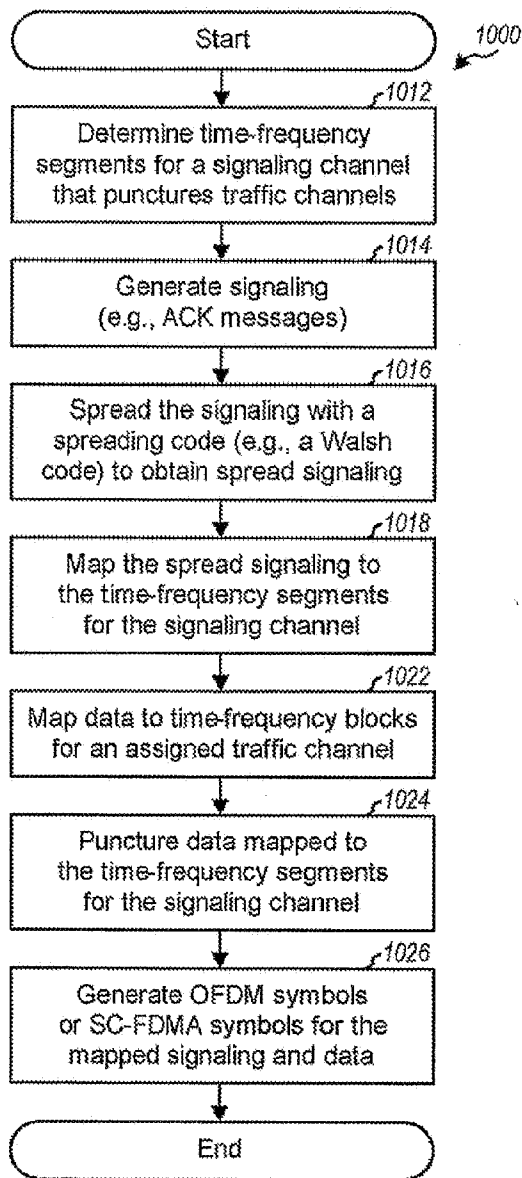

FIG. 10

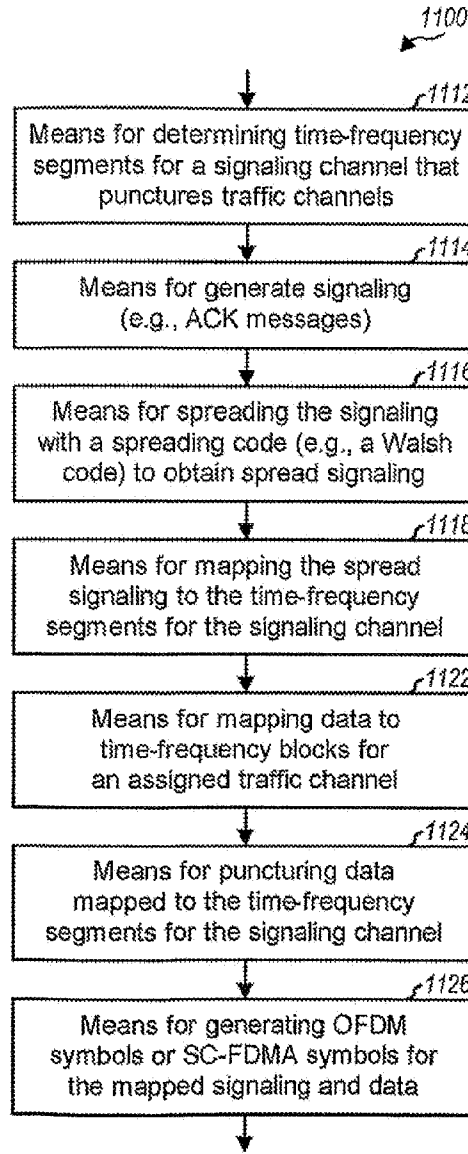

FIG. 11

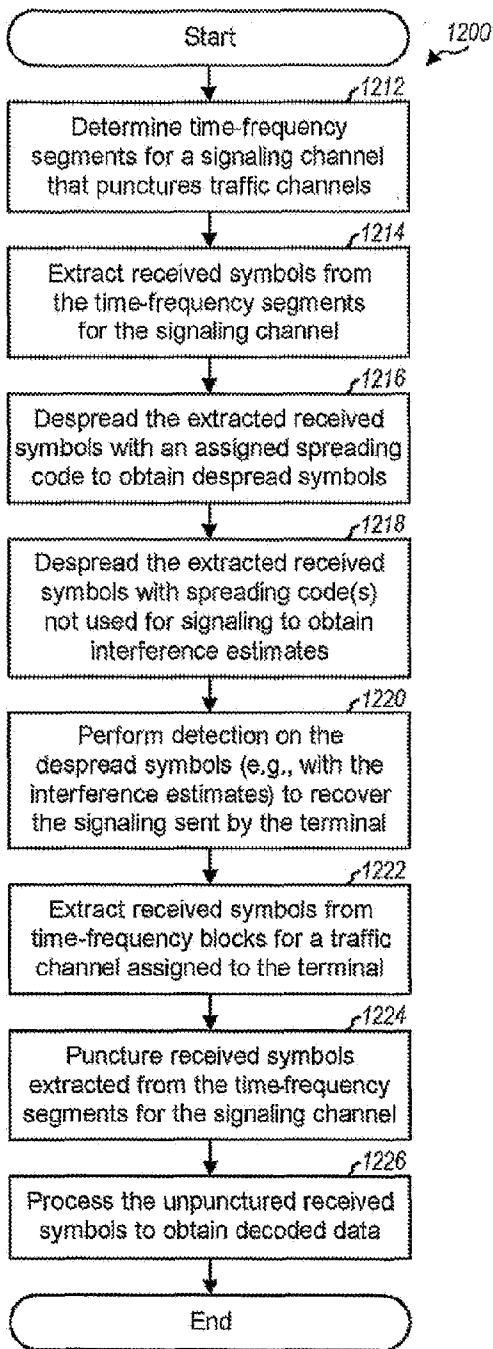

FIG. 12

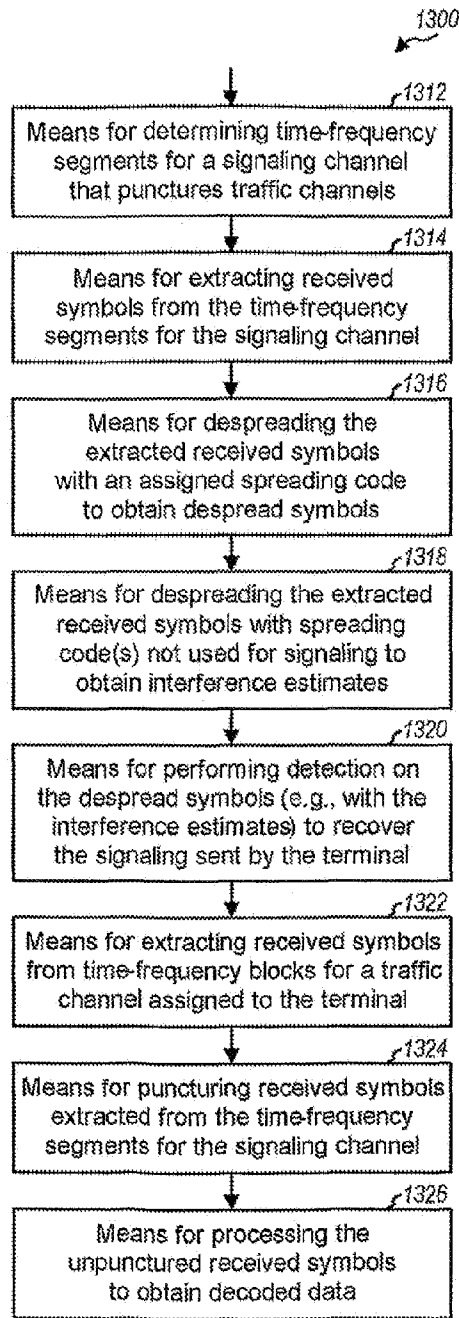

FIG. 13

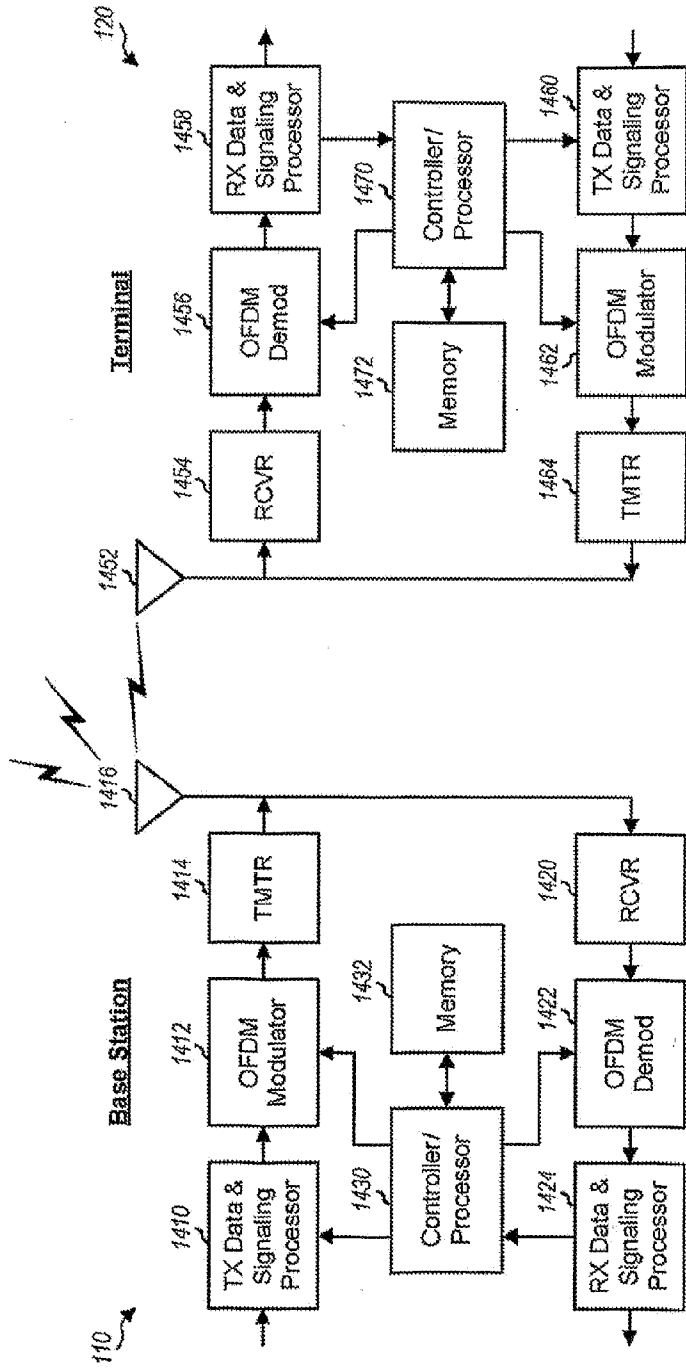

FIG. 14

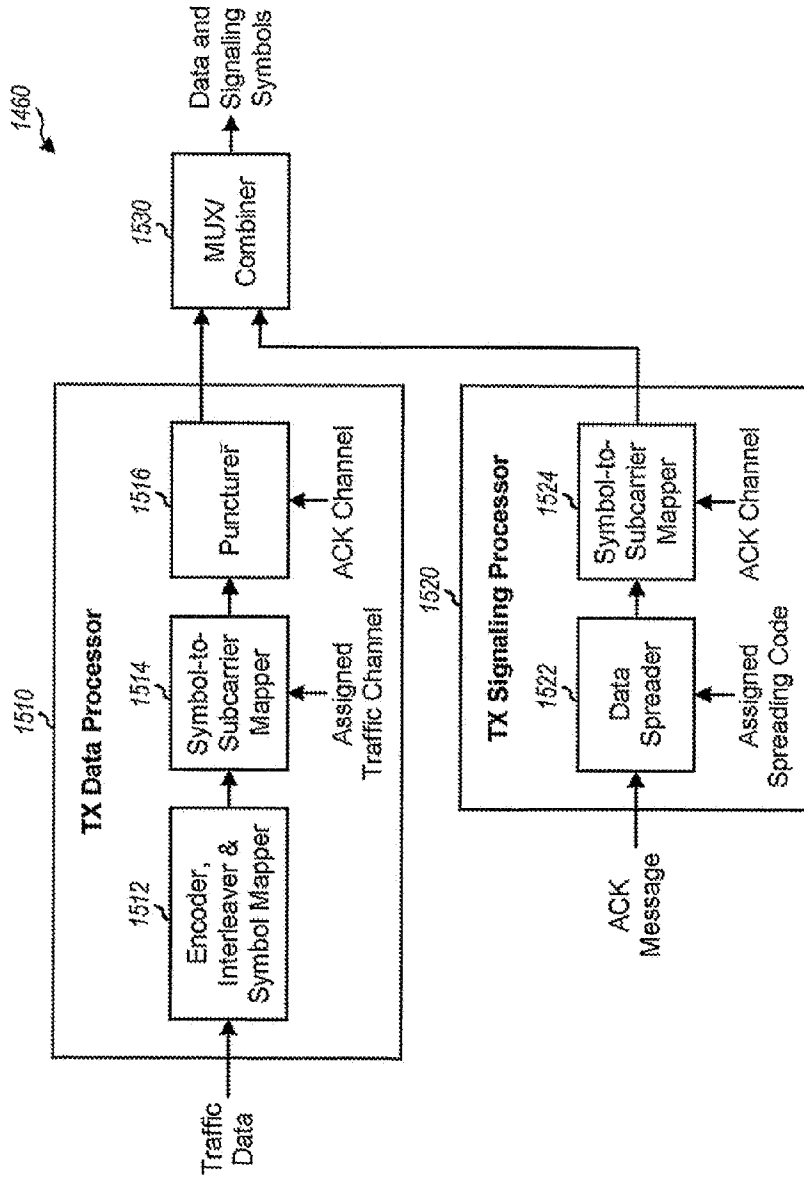

FIG. 15

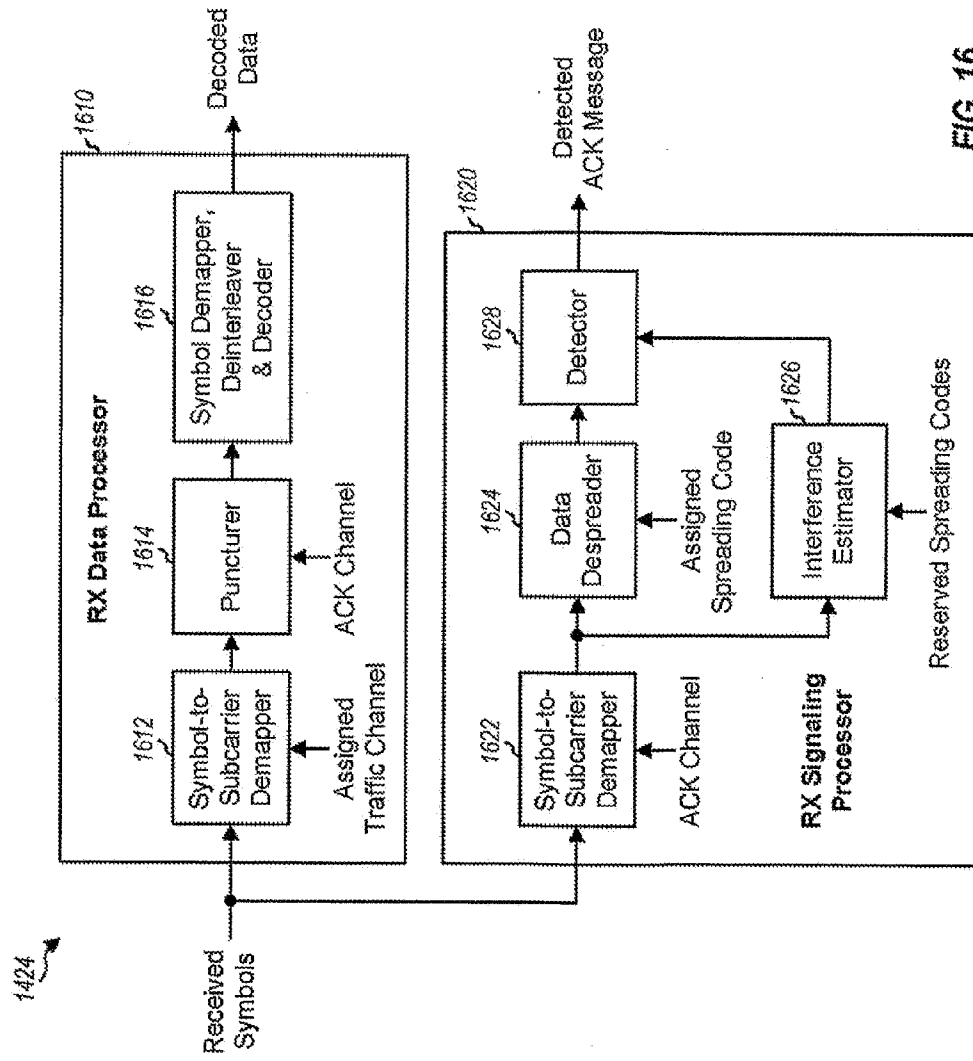

FIG. 16