



(19) **United States**

(12) **Patent Application Publication**

Wilson et al.

(10) **Pub. No.: US 2004/0099533 A1**

(43) **Pub. Date: May 27, 2004**

(54) **SYSTEM FOR ELECTROCHEMICALLY PROCESSING A WORKPIECE**

Publication Classification

(76) Inventors: **Gregory J. Wilson**, Kalispell, MT (US); **Paul R. McHugh**, Kalispell, MT (US); **Kyle M. Hanson**, Kalispell, MT (US)

(51) **Int. Cl.⁷** **C25D 5/00**; C25D 17/00
(52) **U.S. Cl.** **205/96**; 204/224 R; 205/133

(57) **ABSTRACT**

Correspondence Address:
PERKINS COIE LLP
PATENT-SEA
P.O. BOX 1247
SEATTLE, WA 98111-1247 (US)

A reactor for electrochemically processing at least one surface of a microelectronic workpiece is set forth. The reactor comprises a reactor head including a workpiece support that has one or more electrical contacts positioned to make electrical contact with the microelectronic workpiece. The reactor also includes a processing container having a plurality of nozzles angularly disposed in a sidewall of a principal fluid flow chamber at a level within the principal fluid flow chamber below a surface of a bath of processing fluid normally contained therein during electrochemical processing. A plurality of anodes are disposed at different elevations in the principal fluid flow chamber so as to place them at difference distances from a microelectronic workpiece under process without an intermediate diffuser between the plurality of anodes and the microelectronic workpiece under process. One or more of the plurality of anodes may be in close proximity to the workpiece under process. Still further, one or more of the plurality of anodes may be a virtual anode. The present invention also related to multi-level anode configurations within a principal fluid flow chamber and methods of using the same.

(21) Appl. No.: **10/715,700**

(22) Filed: **Nov. 18, 2003**

Related U.S. Application Data

(63) Continuation of application No. 09/804,697, filed on Mar. 12, 2001, now Pat. No. 6,660,137, which is a continuation of application No. PCT/US00/10120, filed on Apr. 13, 2000.

(60) Provisional application No. 60/129,055, filed on Apr. 13, 1999. Provisional application No. 60/143,769, filed on Jul. 12, 1999. Provisional application No. 60/182,160, filed on Feb. 14, 2000.

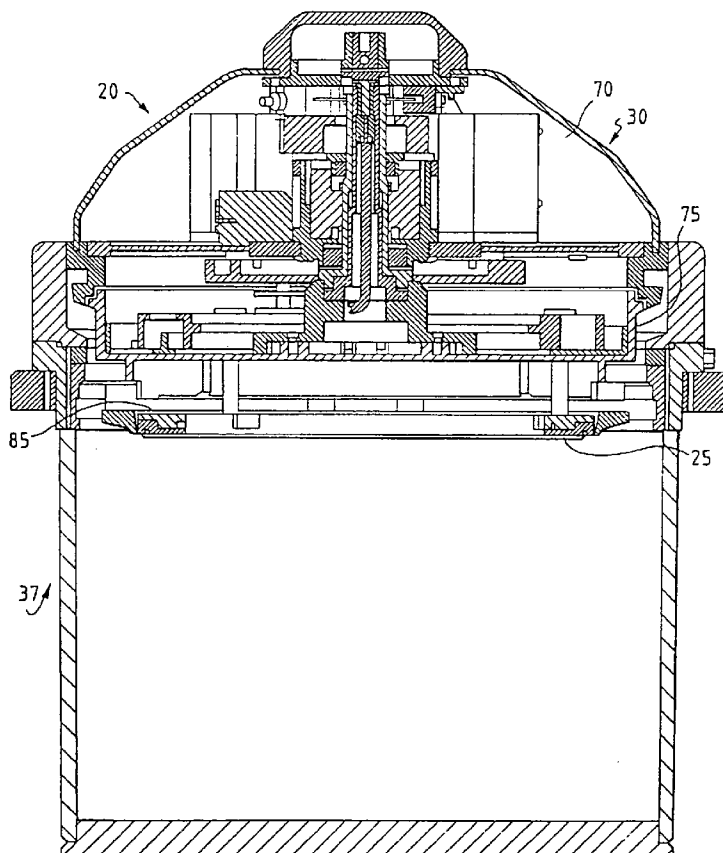

FIG. 1A
PRIOR ART

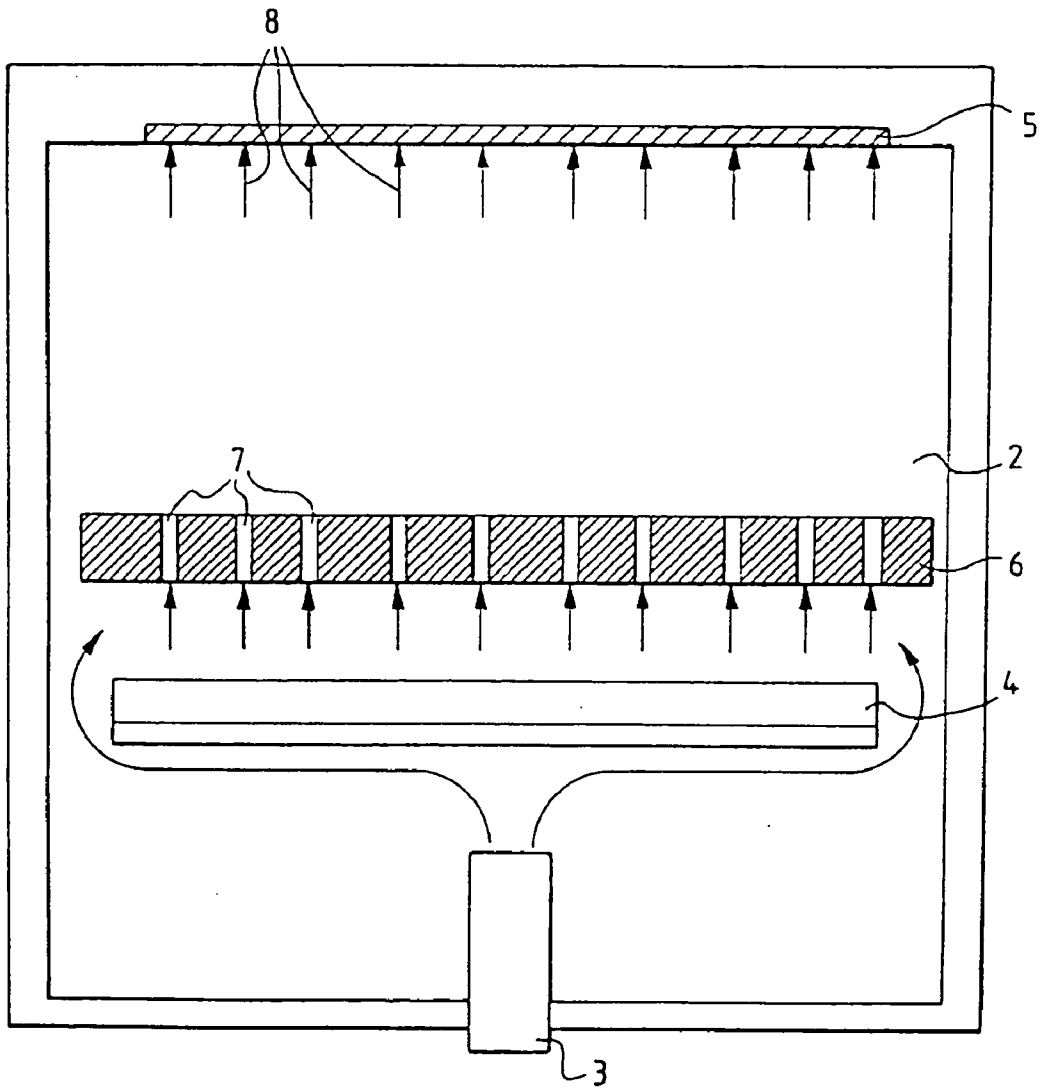
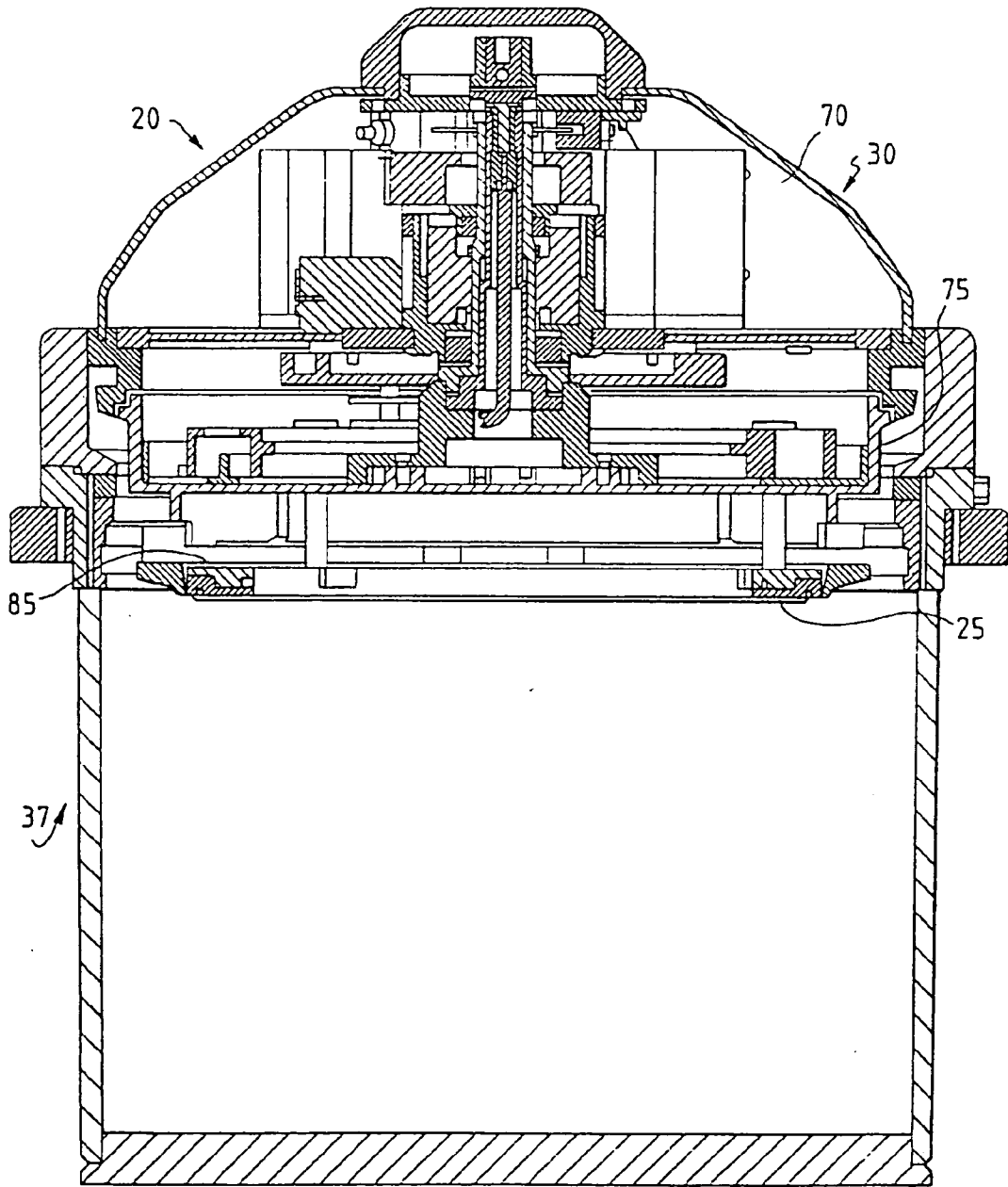

FIG. 1B



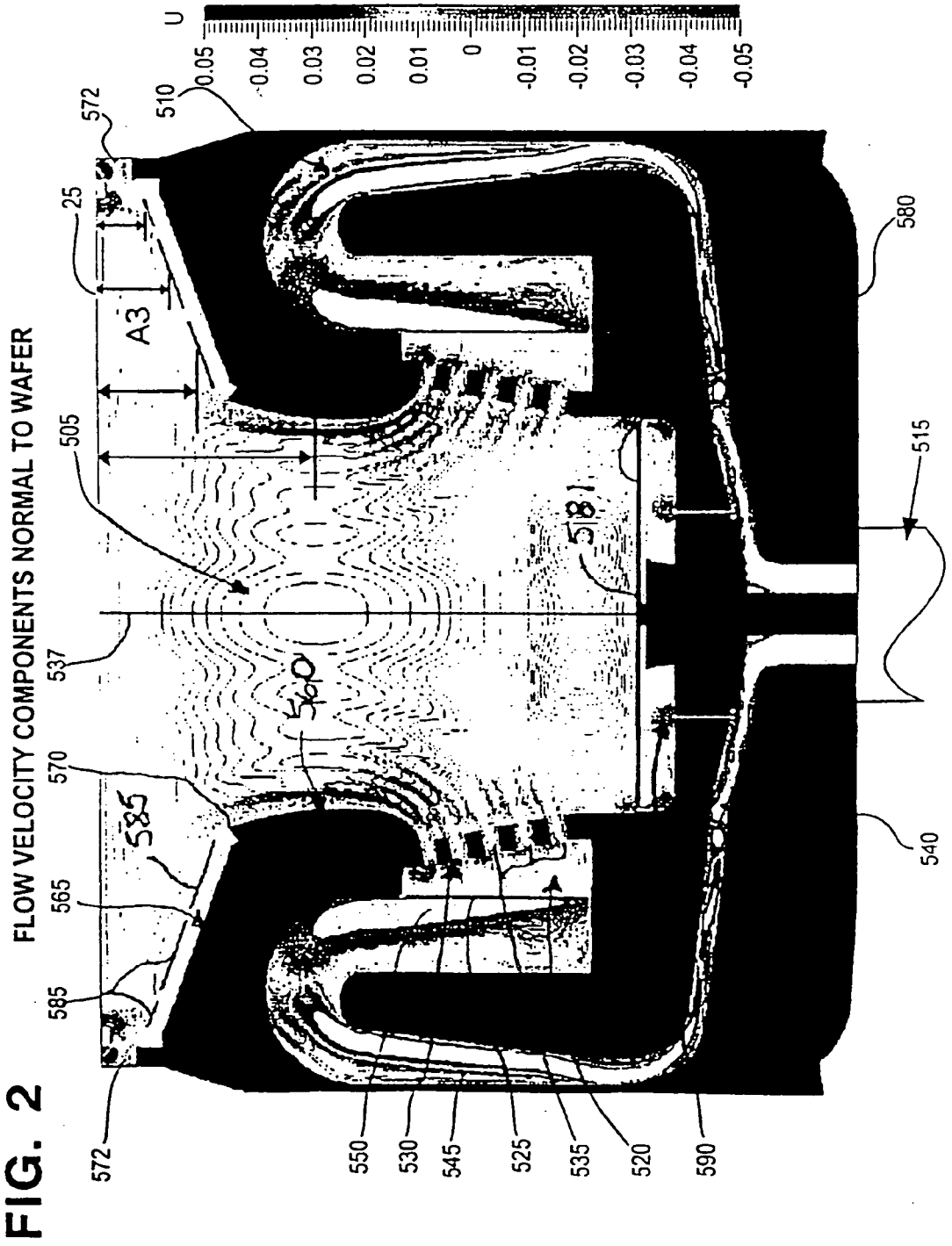

FIG. 3A

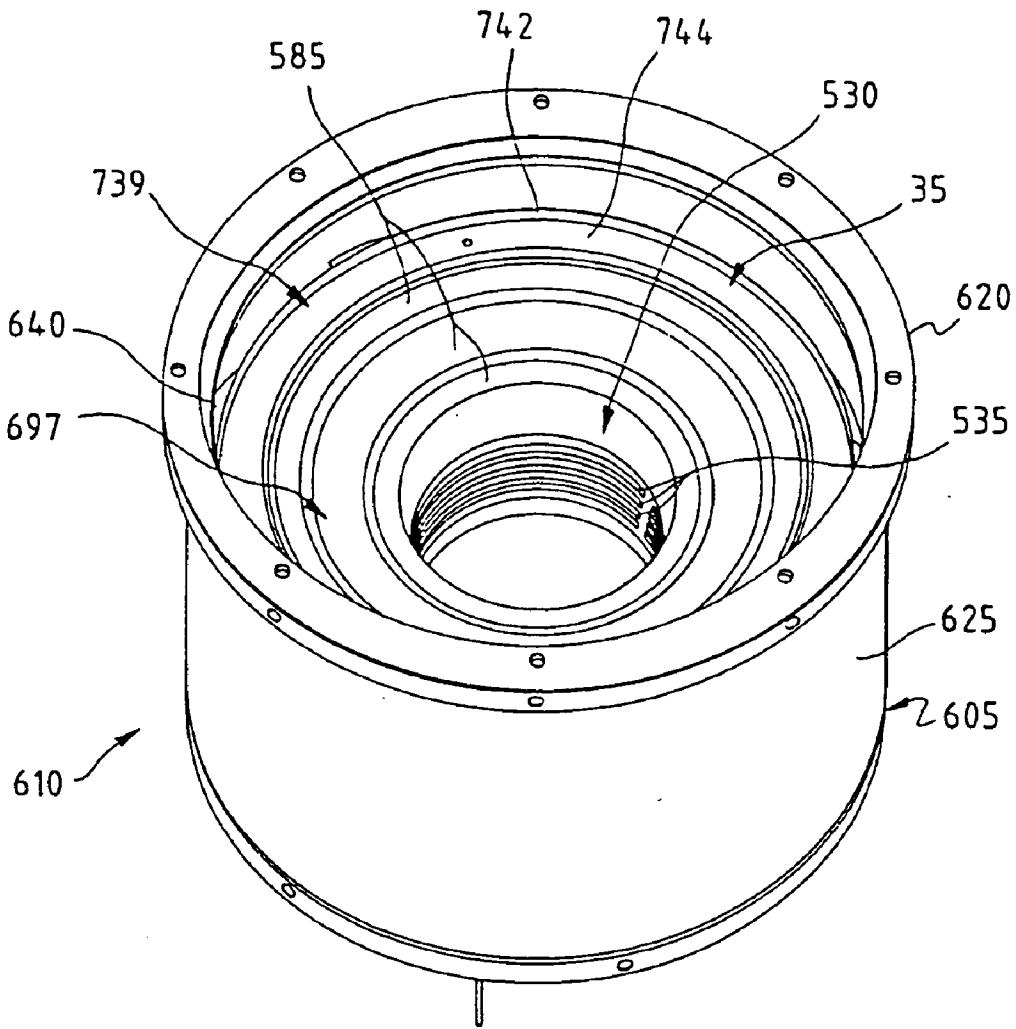

FIG. 3B

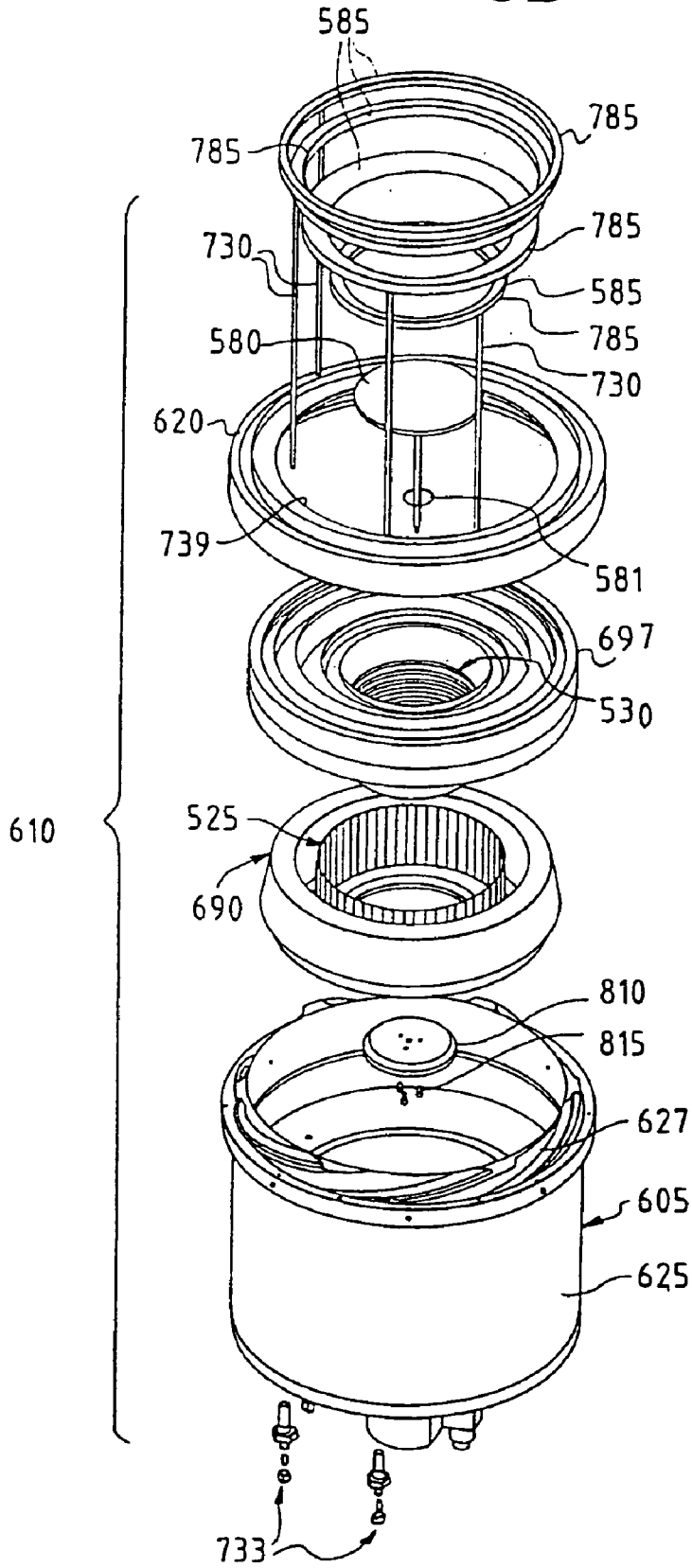

FIG. 4

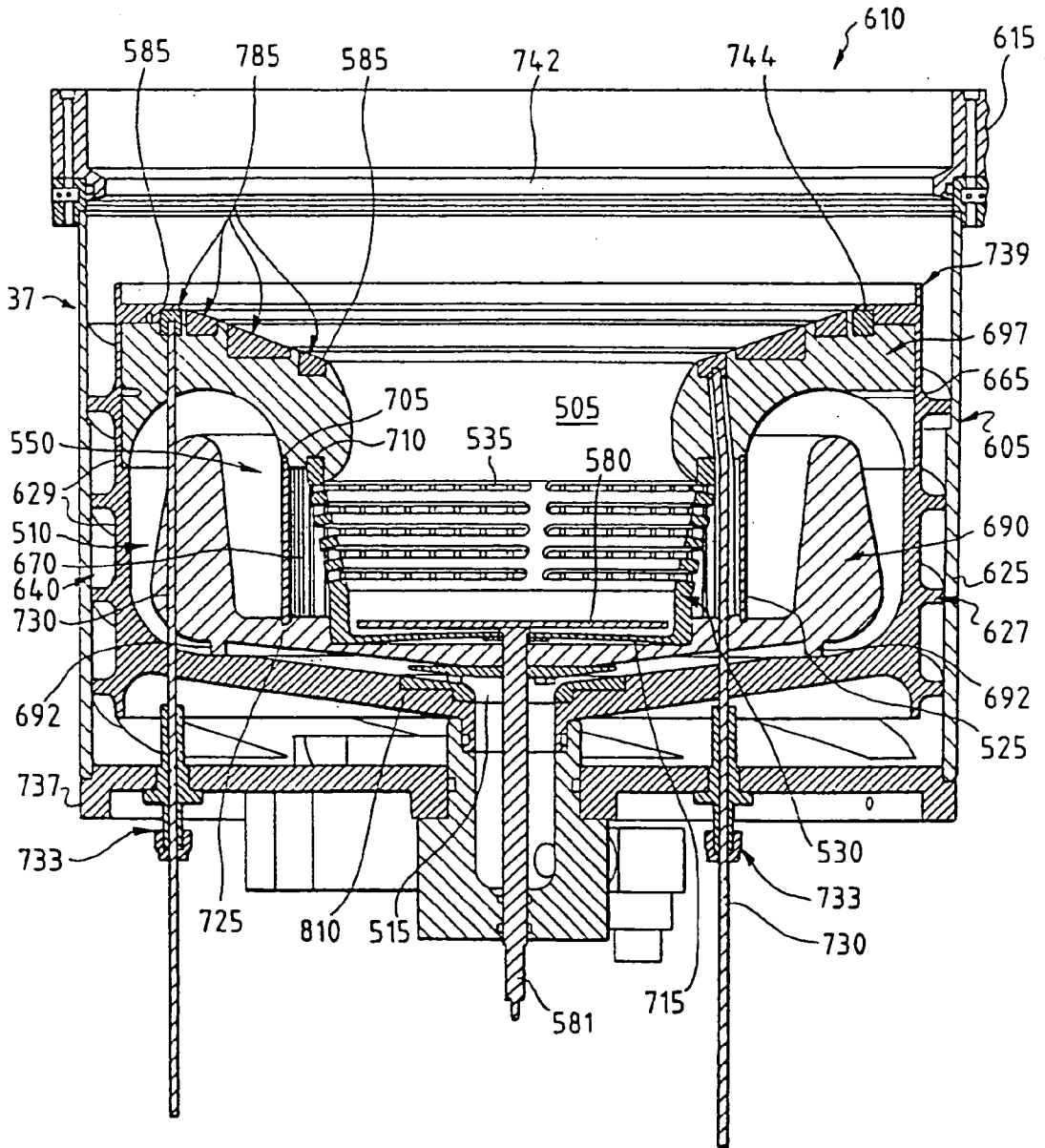

FIG. 5

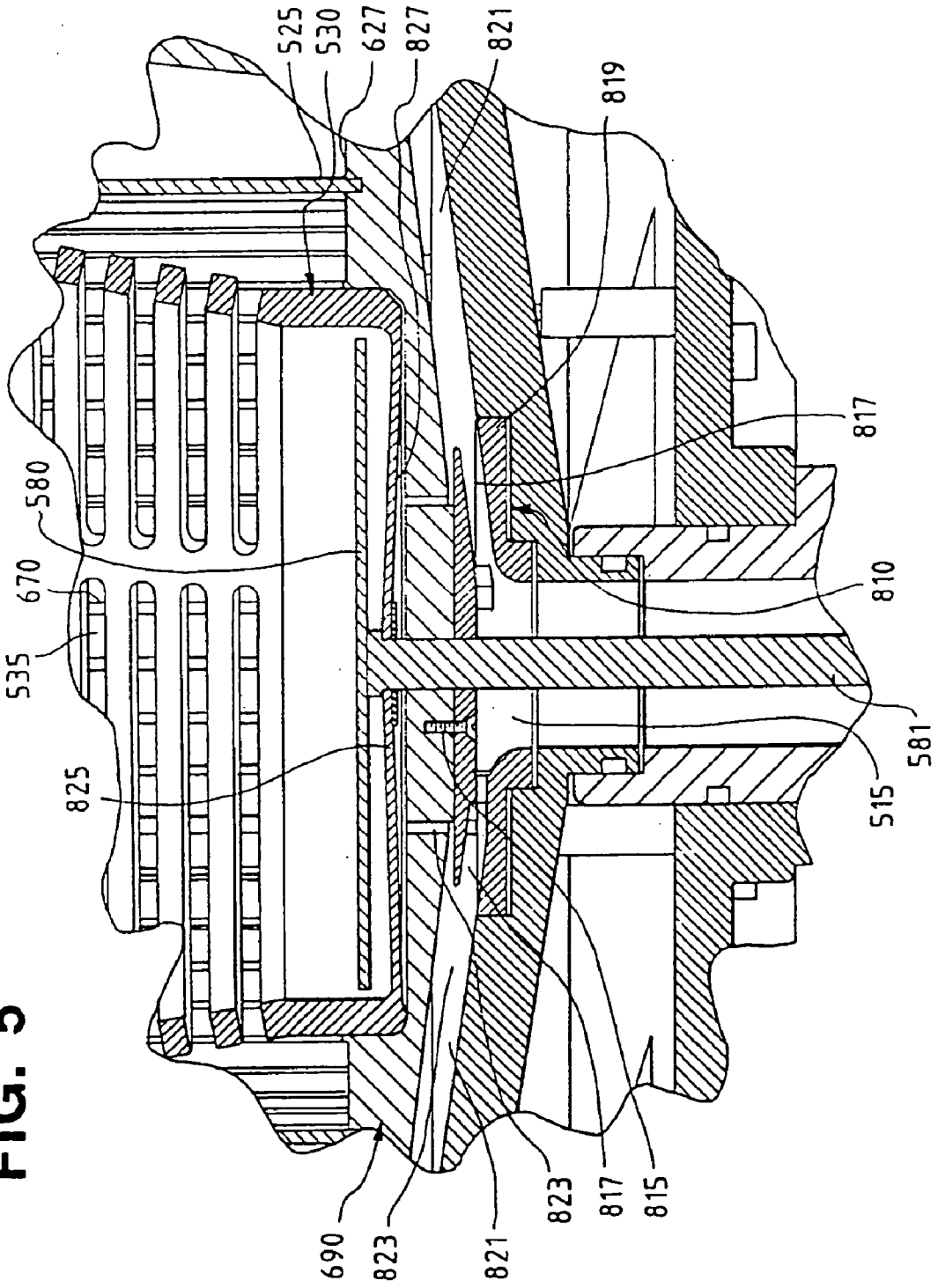
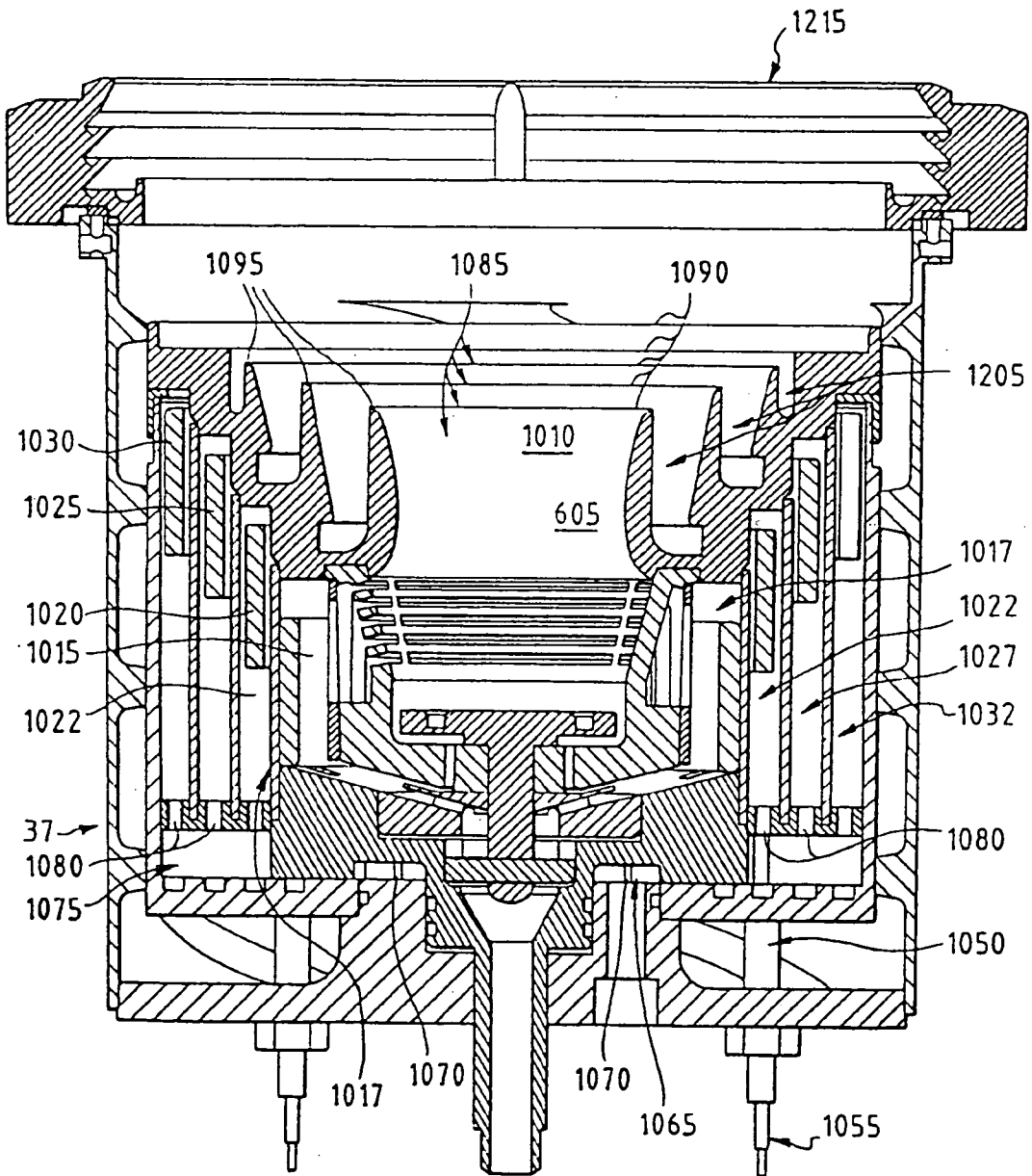
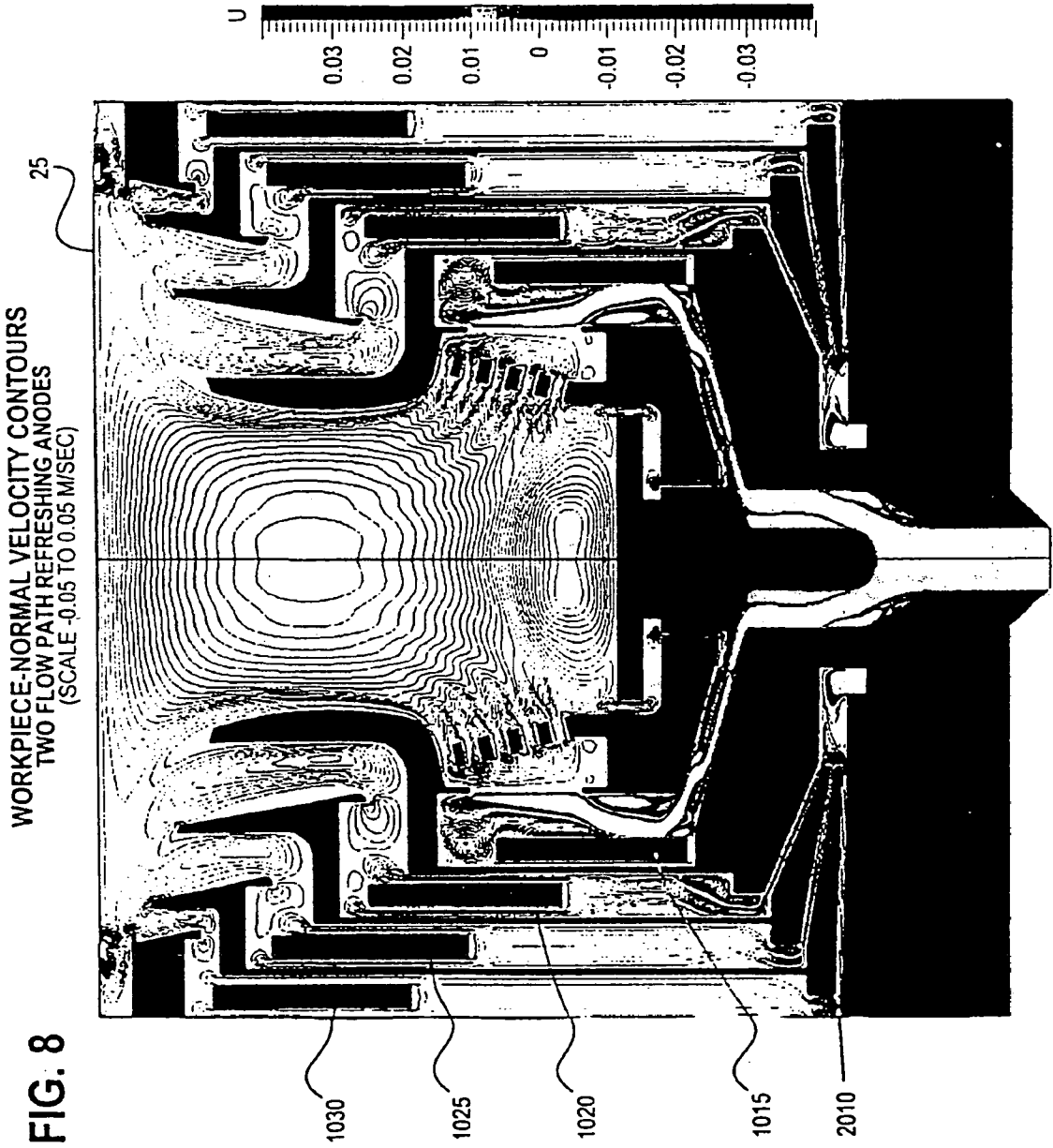
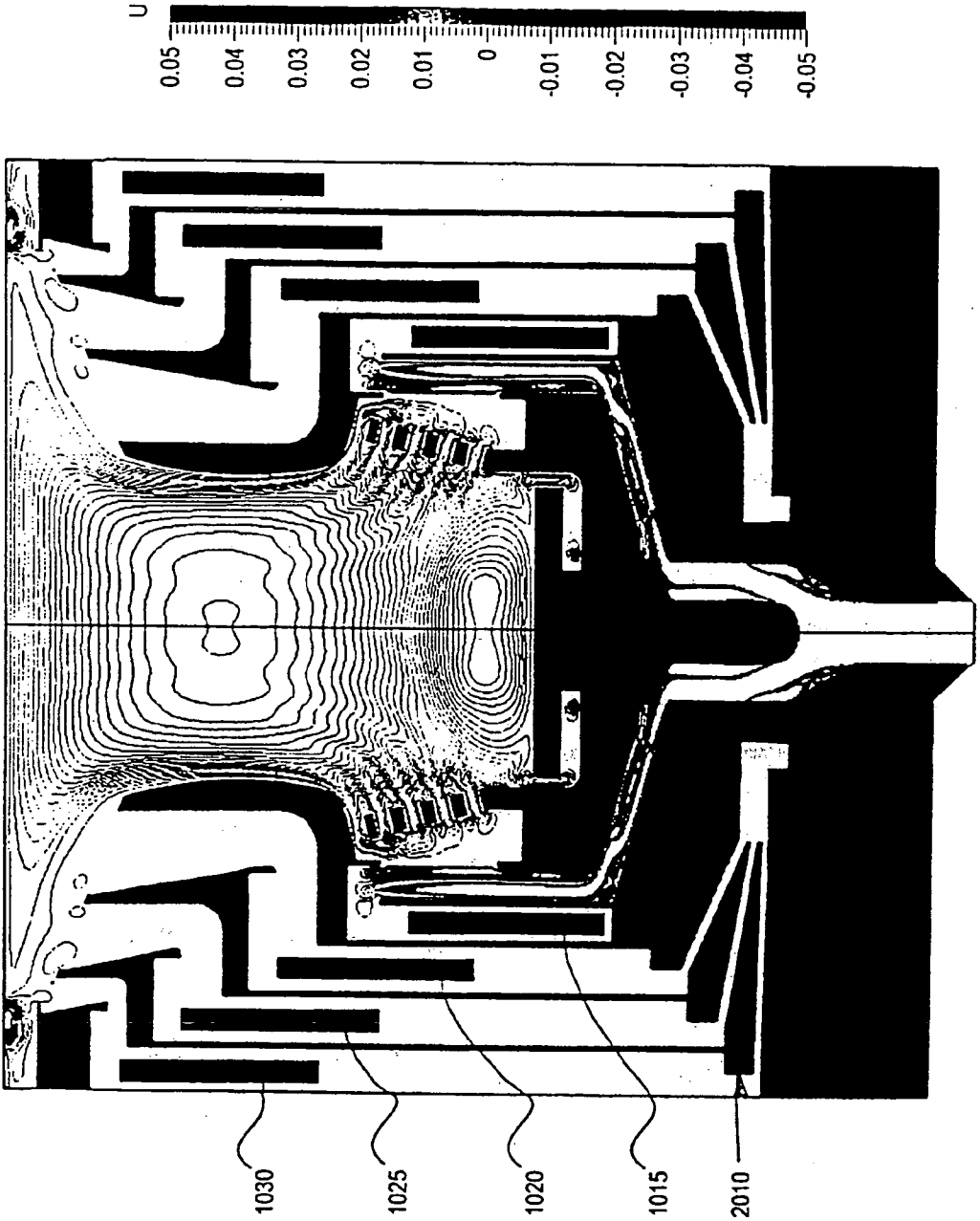

FIG. 7





WORKPIECE-NORMAL VELOCITY CONTOURS
SINGLE FLOW PATH (NO FLOW OVER ANODES)
(SCALE -0.05 TO 0.05 M/SEC)



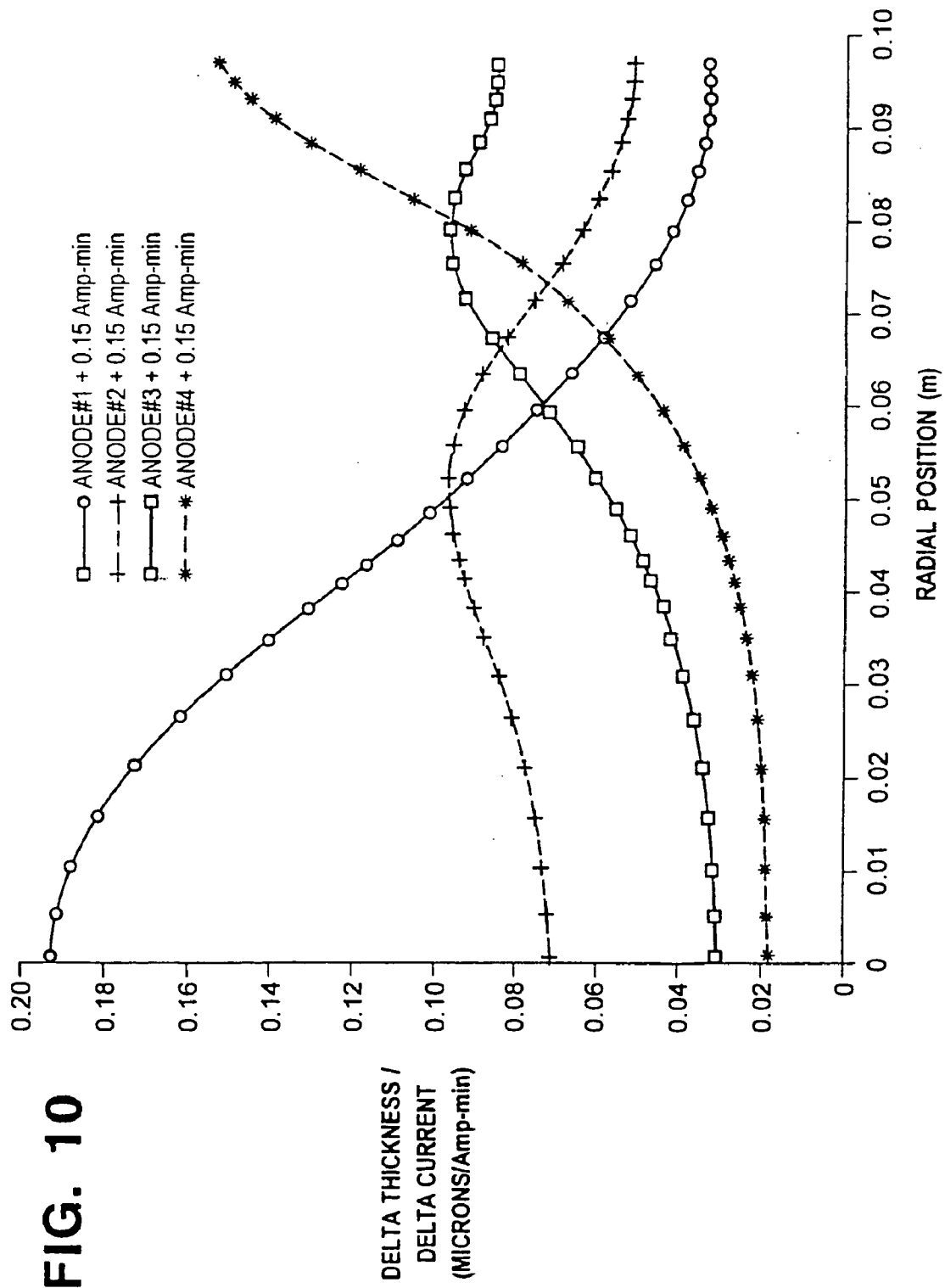

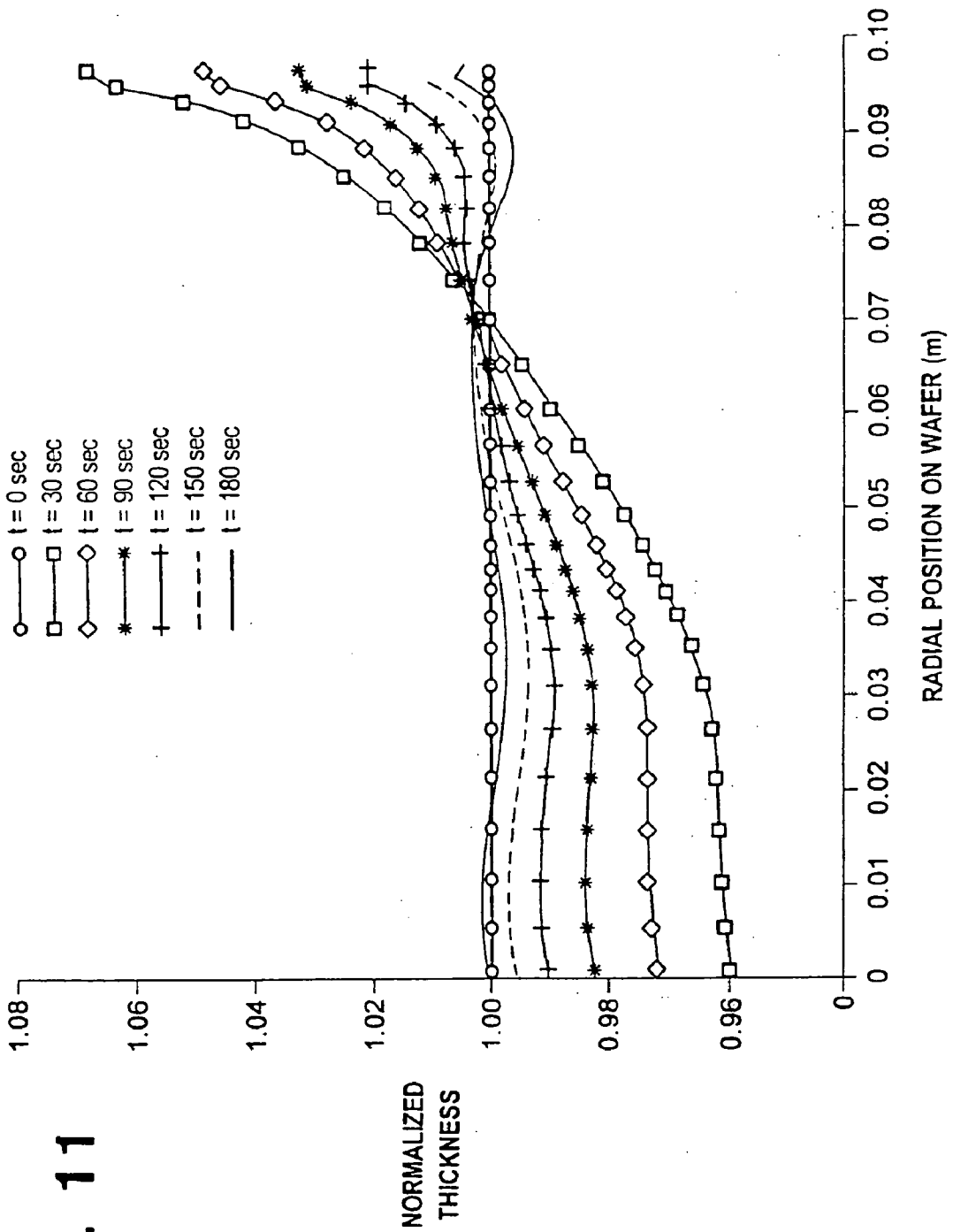

FIG. 11

FIG. 12

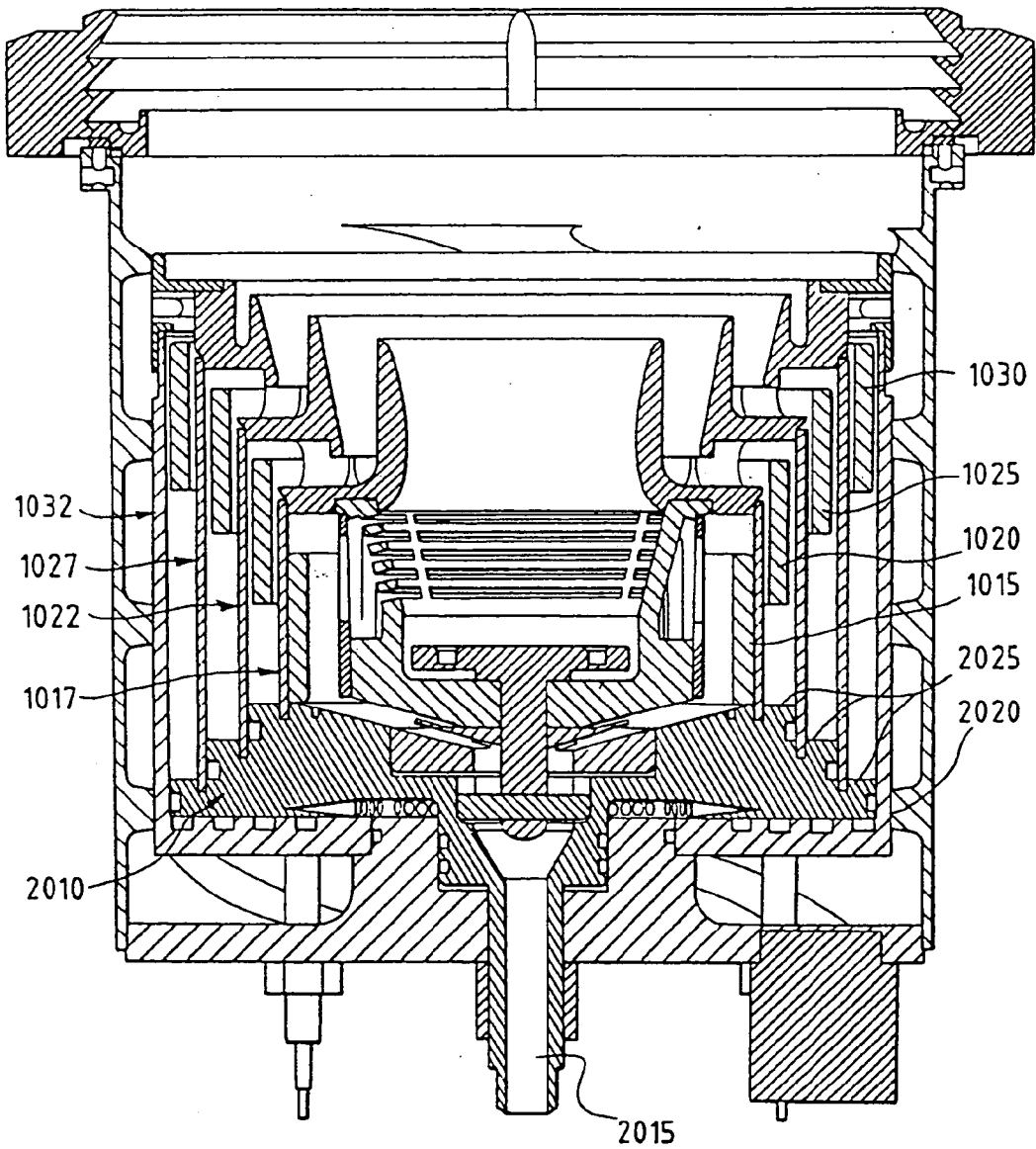

FIG. 13

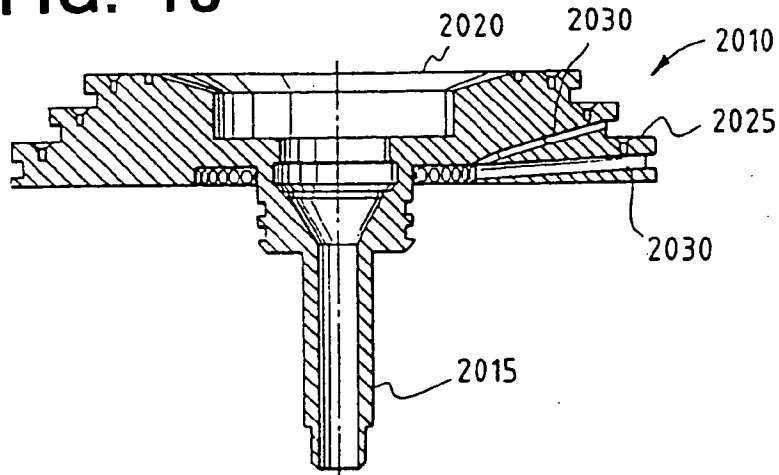

FIG. 14

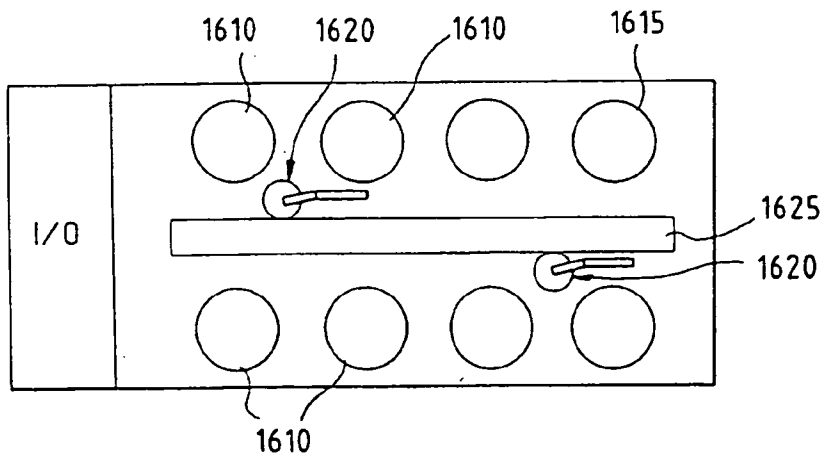
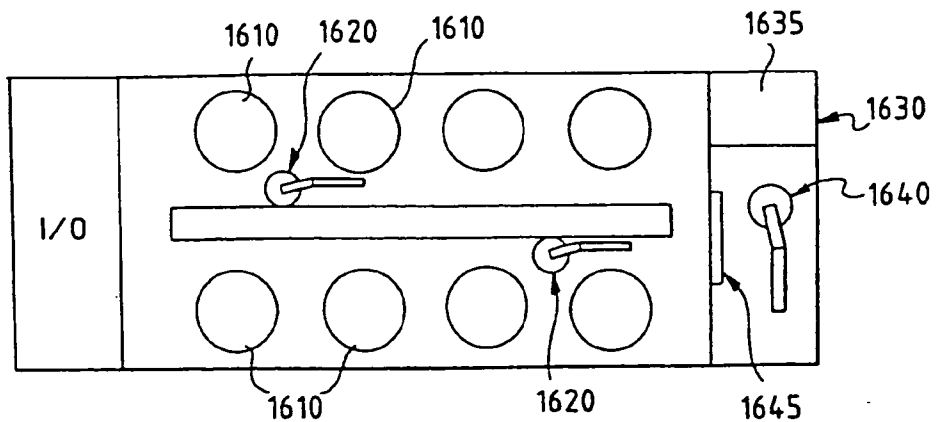

FIG. 15



SYSTEM FOR ELECTROCHEMICALLY PROCESSING A WORKPIECE

CROSS-REFERENCE TO RELATED APPLICATIONS

[0001] The present application is a continuation of prior International Application No. PCT/US00/10120, filed on Apr. 13, 2000 in the English language and published in the English language as International Publication No. WO00/61498, which in turn claims priority to the following three US Provisional Applications: U.S. Ser. No. 60/129,055, entitled "WORKPIECE PROCESSOR HAVING IMPROVED PROCESSING CHAMBER", filed Apr. 13, 1999; U.S. Ser. No. 60/143,769, entitled "WORKPIECE PROCESSING HAVING IMPROVED PROCESSING CHAMBER", filed Jul. 12, 1999; U.S. Ser. No. 60/182,160 entitled "WORKPIECE PROCESSOR HAVING IMPROVED PROCESSING CHAMBER", filed Feb. 14, 2000. The entire disclosures of all three of the prior applications, as well as International Publication No. WO00/61498, are incorporated herein by reference.

STATEMENT REGARDING FEDERALLY SPONSORED RESEARCH OR DEVELOPMENT

[0002] Not Applicable

BACKGROUND OF THE INVENTION

[0003] The fabrication of microelectronic components from a microelectronic workpiece, such as a semiconductor wafer substrate, polymer substrate, etc., involves a substantial number of processes. For purposes of the present application, a microelectronic workpiece is defined to include a workpiece formed from a substrate upon which microelectronic circuits or components, data storage elements or layers, and/or micro-mechanical elements are formed. There are a number of different processing operations performed on the microelectronic workpiece to fabricate the microelectronic component(s). Such operations include, for example, material deposition, patterning, doping, chemical mechanical polishing, electropolishing, and heat treatment.

[0004] Material deposition processing involves depositing or otherwise forming thin layers of material on the surface of the microelectronic workpiece (hereinafter described as, but not limited to, a semiconductor wafer). Patterning provides removal of selected portions of these added layers. Doping of the semiconductor wafer, or similar microelectronic workpiece, is the process of adding impurities known as "dopants" to the selected portions of the wafer to alter the electrical characteristics of the substrate material. Heat treatment of the semiconductor wafer involves heating and/or cooling the wafer to achieve specific process results. Chemical mechanical polishing involves the removal of material through a combined chemical/mechanical process while electropolishing involves the removal of material from a workpiece surface using electrochemical reactions.

[0005] Numerous processing devices, known as processing "tools", have been developed to implement the foregoing processing operations. These tools take on different configurations depending on the type of workpiece used in the fabrication process and the process or processes executed by the tool. One tool configuration, known as the LT-210C™ processing tool and available from Semitool,

Inc., of Kalispell, Mont., includes a plurality, of microelectronic workpiece processing stations that utilize a workpiece holder and a process bowl or container for implementing wet processing operations. Such wet processing operations include electroplating, etching, cleaning, electroless deposition, electropolishing, etc.. In connection with the present invention, it is the electrochemical processing stations used in the LT-210C™ that are noteworthy. Such electrochemical processing stations perform the foregoing electroplating, electropolishing, anodization, etc., of the microelectronic workpiece. It will be recognized that the electrochemical processing system set forth herein is readily adapted to implement each of the foregoing electrochemical processes.

[0006] In accordance with one configuration of the LT-210C™ tool, the electroplating stations include a workpiece holder and a process container that are disposed proximate one another. The workpiece holder and process container are operated to bring the microelectronic workpiece held by the workpiece holder into contact with an electroplating fluid disposed in the process container to form a processing chamber. Restricting the electroplating solution to the appropriate portions of the workpiece, however, is often problematic. Additionally, ensuring proper mass transfer conditions between the electroplating solution and the surface of the workpiece can be difficult. Absent such mass transfer control, the electrochemical processing of the workpiece surface can often be non-uniform. This can be particularly problematic in connection with the electroplating of metals. Still further, control of the shape and magnitude of the electric field is increasingly important.

[0007] Conventional electrochemical reactors have utilized various techniques to bring the electroplating solution into contact with the surface of the workpiece in a controlled manner. For example, the electroplating solution may be brought into contact with the surface of the workpiece using partial or full immersion processing in which the electroplating solution resides in a processing container and at least one surface of the workpiece is brought into contact with or below the surface of the electroplating solution.

[0008] Electroplating and other electrochemical processes have become important in the production of semiconductor integrated circuits and other microelectronic devices from microelectronic workpieces. For example, electroplating is often used in the formation of one or more metal layers on the workpiece. These metal layers are often used to electrically interconnect the various devices of the integrated circuit. Further, the structures formed from the metal layers may constitute microelectronic devices such as read/write heads, etc.

[0009] Electroplated metals typically include copper, nickel, gold, platinum, solder, nickel-iron, etc. Electroplating is generally effected by initial formation of a seed layer on the microelectronic workpiece in the form of a very thin layer of metal, whereby the surface of the microelectronic workpiece is rendered electrically conductive. This conductivity permits subsequent formation of a blanket or patterned layer of the desired metal by electroplating. Subsequent processing, such as chemical mechanical planarization, may be used to remove unwanted portions of the patterned or metal blanket layer formed during electroplating, resulting in the formation of the desired metallized structure.

[0010] Electropolishing of metals at the surface of a workpiece involves the removal of at least some of the metal using an electrochemical process. The electrochemical process is effectively the reverse of the electroplating reaction and is often carried out using the same or similar reactors as electroplating.

[0011] Existing electroplating processing containers often provide a continuous flow of electroplating solution to the electroplating chamber through a single inlet disposed at the bottom portion of the chamber. One embodiment of such a processing container is illustrated in FIG. 1A. As illustrated, the electroplating reactor, shown generally at 1, includes a electroplating processing container 2 that is used to contain a flow of electroplating solution provided through a fluid inlet 3 disposed at a lower portion of the container 2. In such a reactor, the electroplating solution completes an electrical circuit path between an anode 4 and a surface of workpiece 5, which functions as a cathode.

[0012] The electroplating reactions that take place at the surface of the microelectronic workpiece are dependent on species mass transport (e.g., copper ions, platinum ions, gold ions, etc.) to the microelectronic workpiece surface through a diffusion layer (a.k.a., mass transport layer) that forms proximate the microelectronic workpiece's surface. It is desirable to have a diffusion layer that is both thin and uniform over the surface of the microelectronic workpiece if a uniform electroplated film is to be deposited within a reasonable amount of time.

[0013] Even distribution of the electroplating solution over the workpiece surface to control the thickness and uniformity of the diffusion layer in the processing container of FIG. 1A is facilitated, for example, by a diffuser 6 or the like that is disposed between the single inlet and the workpiece surface. The diffuser includes a plurality of apertures 7 that are provided to disburse the stream of electroplating fluid provided from the processing fluid inlet 3 as evenly as possible across the surface of the workpiece 5.

[0014] Although substantial improvements in diffusion layer control result from the use of a diffuser, such control is limited. With reference to FIG. 1A, localized areas 8 of increased flow velocity normal to the surface of the microelectronic workpiece are often generated by the diffuser 6. These localized areas generally correspond to the position of apertures 7 of the diffuser 6. This effect is increased as the diffuser 6 is moved closer to the workpiece.

[0015] The present inventors have found that these localized areas of increased flow velocity at the surface of the workpiece affect the diffusion layer conditions and can result in non-uniform deposition of the electroplated material over the surface of the workpiece. Diffuser hole pattern configurations also affect the distribution of the electric field since the diffuser is disposed between the anode and workpiece, and can result in non-uniform deposition of the electroplated material. In the reactor illustrated in FIG. 1A, the electric field tends to be concentrated at localized areas 8 corresponding to the apertures in the diffuser. These effects in the localized areas 8 are dependent on diffuser distance from the workpiece and the diffuser hole size and pattern.

[0016] Another problem often encountered in electroplating is disruption of the diffusion layer due to the entrapment and evolution of gasses during the electroplating process.

For example, bubbles can be created in the plumbing and pumping system of the processing equipment. Electroplating is thus inhibited at those sites on the surface of the workpiece to which the bubbles migrate. Gas evolution is particularly a concern when an inert anode is utilized since inert anodes tend to generate gas bubbles as a result of the anodic reactions that take place at the anode's surface.

[0017] Consumable anodes are often used to reduce the evolution of gas bubbles in the electroplating solution and to maintain bath stability. However, consumable anodes frequently have a passivated film surface that must be maintained. They also erode into the plating solution changing the dimensional tolerances. Ultimately, they must be replaced thereby increasing the amount of maintenance required to keep the tool operational when compared to tools using inert anodes.

[0018] Another challenge associated with the plating of uniform films is the changing resistance of the plated film. The initial seed layer can have a high resistance and this resistance decreases as the film becomes thicker. The changing resistance makes it difficult for a given set of chamber hardware to yield optimal uniformity on a variety of seed layers and deposited film thicknesses.

[0019] In view of the foregoing, the present inventors have developed a system for electrochemically processing a microelectronic workpiece that can readily adapt to a wide range of electrochemical processing requirements (e.g., seed layer thicknesses, seed layer types, electroplating materials, electrolyte bath properties, etc.). The system can adapt to such electrochemical processing requirements while concurrently providing a controlled, substantially uniform diffusion layer at the surface of the workpiece that assists in providing a corresponding substantially uniform processing of the workpiece surface (e.g., uniform deposition of the electroplated material).

BRIEF DESCRIPTION OF THE DRAWINGS

[0020] FIG. 1A is schematic block diagram of an immersion processing reactor assembly that incorporates a diffuser to distribute a flow of processing fluid across a surface of a workpiece.

[0021] FIG. 1B is a cross-sectional view of one embodiment of a reactor assembly that may incorporate the present invention.

[0022] FIG. 2 is a schematic diagram of one embodiment of a reactor chamber that may be used in the reactor assembly of FIG. 1B and includes an illustration of the velocity flow profiles associated with the flow of processing fluid through the reactor chamber.

[0023] FIGS. 3A-5 illustrate a specific construction of a complete processing chamber assembly that has been specifically adapted for electrochemical processing of a semiconductor wafer and that has been implemented to achieve the velocity flow profiles set forth in FIG. 2.

[0024] FIGS. 6 and 7 illustrate two embodiments of processing tools that may incorporate one or more processing stations constructed in accordance with the teachings of the present invention.

[0025] FIGS. 8 and 9 are a cross-sectional views of illustrative velocity flow contours of the processing chamber embodiment of FIGS. 6 and 7.

[0026] FIGS. 10 and 11 are graphs illustrating the manner in which the anode configuration of the processing chamber may be employed to achieve uniform plating.

[0027] FIGS. 12 and 13 illustrate a modified version of the processing chamber of FIGS. 6 and 7.

[0028] FIGS. 14 and 15 illustrate two embodiments of processing tools that may incorporate one or more processing stations constructed in accordance with the teachings of the present invention.

SUMMARY OF THE INVENTIONS

[0029] A reactor for electrochemically processing at least one surface of a microelectronic workpiece is set forth. The reactor comprises a reactor head including a workpiece support that has one or more electrical contacts positioned to make electrical contact with the microelectronic workpiece. The reactor also includes a processing container having a plurality of nozzles angularly disposed in a sidewall of a principal fluid flow chamber at a level within the principal fluid flow chamber below a surface of a bath of processing fluid normally contained therein during electrochemical processing. A plurality of anodes are disposed at different elevations in the principal fluid flow chamber so as to place them at different distances from a microelectronic workpiece under process without an intermediate diffuser between the plurality of anodes and the microelectronic workpiece under process. One or more of the plurality of anodes may be in close proximity to the workpiece under process. Still further, one or more of the plurality of anodes may be a virtual anode. The present invention also relates to multi-level anode configurations within a principal fluid flow chamber and methods of using the same.

DETAILED DESCRIPTION OF THE INVENTION

[0030] Basic Reactor Components

[0031] With reference to FIG. 1B, there is shown a reactor assembly 20 for electroplating a microelectronic workpiece 25, such as a semiconductor wafer. Generally stated, the reactor assembly 20 is comprised of a reactor head 30 and a corresponding reactor base, shown generally at 37 and described in substantial detail below, in which the electroplating solution is disposed. The reactor of FIG. 1B can also be used to implement electrochemical processing operations other than electroplating (e.g., electropolishing, anodization, etc.).

[0032] The reactor head 30 of the electroplating reactor assembly may comprised of a stationary assembly 70 and a rotor assembly 75. Rotor assembly 75 is configured to receive and carry an associated microelectronic workpiece 25, position the microelectronic workpiece in a process-side down orientation within a container of reactor base 37, and to rotate or spin the workpiece while joining its electrically-conductive surface in the plating circuit of the reactor assembly 20. The rotor assembly 75 includes one or more cathode contacts that provide electroplating power to the surface of the microelectronic workpiece. In the illustrated embodiment, a cathode contact assembly is shown generally at 85 and is described in further detail below. It will be recognized, however, that backside contact may be implemented in lieu of front side contact when the substrate is

conductive or when an alternative electrically conductive path is provided between the back side of the microelectronic workpiece and the front side thereof.

[0033] The reactor head 30 is typically mounted on a lift/rotate apparatus which is configured to rotate the reactor head 30 from an upwardly-facing disposition in which it receives the microelectronic workpiece to be plated, to a downwardly facing disposition in which the surface of the microelectronic workpiece to be plated is positioned so that it may be brought into contact with the electroplating solution in reactor base 37, either planar or at a given angle. A robotic arm, which preferably includes an end effector, is typically employed for placing the microelectronic workpiece 25 in position on the rotor assembly 75, and for removing the plated microelectronic workpiece from within the rotor assembly. The contact assembly 85 may be operated between an open state that allows the microelectronic workpiece to be placed on the rotor assembly 75, and a closed state that secures the microelectronic workpiece to the rotor assembly and brings the electrically conductive components of the contact assembly 85 into electrical engagement with the surface of the microelectronic workpiece that is to be plated.

[0034] It will be recognized that other reactor assembly configurations may be used with the inventive aspects of the disclosed reactor chamber, the foregoing being merely illustrative.

[0035] Electrochemical Processing Container

[0036] FIG. 2 illustrates the basic construction of processing base 37 and a corresponding computer simulation of the flow velocity contour pattern resulting from the processing container construction. As illustrated, the processing base 37 generally comprises a main fluid flow chamber 505, an antechamber 510, a fluid inlet 515, a plenum 520, a flow diffuser 525 separating the plenum 520 from the antechamber 510, and a nozzle/slot assembly 530 separating the plenum 520 from the main chamber 505. These components cooperate to provide a flow of electrochemical processing fluid (here, of the electroplating solution) at the microelectronic workpiece 25 that has a substantially radially independent normal component. In the illustrated embodiment, the impinging flow is centered about central axis 537 and possesses a nearly uniform component normal to the surface of the microelectronic workpiece 25. This results in a substantially uniform mass flux to the microelectronic workpiece surface that, in turn, enables substantially uniform processing thereof.

[0037] Notably, as will be clear from the description below, this desirable flow characteristic is achieved without the use of a diffuser disposed between the anode(s) and surface of the microelectronic workpiece that is to be electrochemically processed (e.g., electroplated). As such, the anodes used in the electroplating reactor can be placed in close proximity to the surface of the microelectronic workpiece to thereby provide substantial control over local electrical field/current density parameters used in the electroplating process. This substantial degree of control over the electrical parameters allows the reactor to be readily adapted to meet a wide range of electroplating requirements (e.g., seed layer thickness, seed layer type, electroplated material, electrolyte bath properties, etc.) without a corresponding change in the reactor hardware. Rather, adapta-

tions can be implemented by altering the electrical parameters used in the electroplating process through, for example, software control of the power provided to the anodes.

[0038] The reactor design thus effectively de-couples the fluid flow from adjustments to the electric field. An advantage of this approach is that a chamber with nearly ideal flow for electroplating and other electrochemical processes (i.e., a design which provides a substantially uniform diffusion layer across the microelectronic workpiece) may be designed that will not be degraded when electroplating or other electrochemical process applications require significant changes to the electric field.

[0039] The foregoing advantages can be more greatly appreciated through a comparison with the prior art reactor design illustrated in FIG. 1A. In that design, the diffuser must be moved closer to the surface of the workpiece if the distance between the anode and the workpiece surface is to be reduced. However, moving the diffuser closer to the workpiece significantly alters the flow characteristics of the electroplating fluid at the surface of the workpiece. More particularly, the close proximity between the diffuser and the surface of the workpiece introduces a corresponding increase in the magnitude of the normal components of the flow velocity at local areas 8. As such, the anode cannot be moved so that it is in close proximity to the surface of the microelectronic workpiece that is to be electroplated without introducing substantial diffusion layer control problems and undesirable localized increases in the electrical field corresponding to the pattern of apertures in the diffuser. Since the anode cannot be moved in close proximity to the surface of the microelectronic workpiece, the advantages associated with increased control of the electrical characteristics of the electrochemical process cannot be realized. Still further, movement of the diffuser to a position in close proximity with the microelectronic workpiece effectively generates a plurality of virtual anodes defined by the hole pattern of the diffuser. Given the close proximity of these virtual anodes to the microelectronic workpiece surface, the virtual anodes have a highly localized effect. This highly localized effect cannot generally be controlled with any degree of accuracy given that any such control is solely effected by varying the power to the single, real anode. A substantially uniform electroplated film is thus difficult to achieve with such a plurality of loosely controlled virtual anodes.

[0040] With reference again to FIG. 2, electroplating solution is provided through inlet 515 disposed at the bottom of the base 37. The fluid from the inlet 515 is directed therefrom at a relatively high velocity through antechamber 510. In the illustrated embodiment, antechamber 510 includes an acceleration channel 540 through which the electroplating solution flows radially from the fluid inlet 515 toward fluid flow region 545 of antechamber 510. Fluid flow region 545 has a generally inverted U-shaped cross-section that is substantially wider at its outlet region proximate flow diffuser 525 than at its inlet region proximate channel 540. This variation in the cross-section assists in removing any gas bubbles from the electroplating solution before the electroplating solution is allowed to enter the main chamber 505. Gas bubbles that would otherwise enter the main chamber 505 are allowed to exit the processing base 37 through a gas outlet (not illustrated in FIG. 2, but illustrated in the embodiment shown in FIGS. 3-5) disposed at an upper portion of the antechamber 510.

[0041] Electroplating solution within antechamber 510 is ultimately supplied to main chamber 505. To this end, the electroplating solution is first directed to flow from a relatively high-pressure region 550 of the antechamber 510 to the comparatively lower-pressure plenum 520 through flow diffuser 525. Nozzle assembly 530 includes a plurality of nozzles or slots 535 that are disposed at a slight angle with respect to horizontal. Electroplating solution exits plenum 520 through nozzles 535 with fluid velocity components in the vertical and radial directions.

[0042] Main chamber 505 is defined at its upper region by a contoured sidewall 560 and a slanted sidewall 565. The contoured sidewall 560 assists in preventing fluid flow separation as the electroplating solution exits nozzles 535 (particularly the uppermost nozzle(s)) and turns upward toward the surface of microelectronic workpiece 25. Beyond breakpoint 570, fluid flow separation will not substantially affect the uniformity of the normal flow. As such, sidewall 565 can generally have any shape, including a continuation of the shape of contoured sidewall 560. In the specific embodiment disclosed here, sidewall 565 is slanted and, as will be explained in further detail below, is used to support one or more anodes.

[0043] Electroplating solution exits from main chamber 505 through a generally annular outlet 572. Fluid exiting outlet 572 may be provided to a further exterior chamber for disposal or may be replenished for re-circulation through the electroplating solution supply system.

[0044] The processing base 37 is also provided with one or more anodes. In the illustrated embodiment, a principal anode 580 is disposed in the lower portion of the main chamber 505. If the peripheral edges of the surface of the microelectronic workpiece 25 extend radially beyond the extent of contoured sidewall 560, then the peripheral edges are electrically shielded from principal anode 580 and reduced plating will take place in those regions. As such, a plurality of annular anodes 585 are disposed in a generally concentric manner on slanted sidewall 565 to provide a flow of electroplating current to the peripheral regions.

[0045] Anodes 580 and 585 of the illustrated embodiment are disposed at different distances from the surface of the microelectronic workpiece 25 that is being electroplated. More particularly, the anodes 580 and 585 are concentrically disposed in different horizontal planes. Such a concentric arrangement combined with the vertical differences allow the anodes 580 and 585 to be effectively placed close to the surface of the microelectronic workpiece 25 without generating a corresponding adverse impact on the flow pattern as tailored by nozzles 535.

[0046] The effect and degree of control that an anode has on the electroplating of microelectronic workpiece 25 is dependent on the effective distance between that anode and the surface of the microelectronic workpiece that is being electroplated. More particularly, all other things being equal, an anode that is effectively spaced a given distance from the surface of microelectronic workpiece 25 will have an impact on a larger area of the microelectronic workpiece surface than an anode that is effectively spaced from the surface of microelectronic workpiece 25 by a lesser amount. Anodes that are effectively spaced at a comparatively large distance from the surface of microelectronic workpiece 25 thus have less localized control over the electroplating process than do

those that are spaced at a smaller distance. It is therefore desirable to effectively locate the anodes in close proximity to the surface of microelectronic workpiece **25** since this allows more versatile, localized control of the electroplating process. Advantage can be taken of this increased control to achieve greater uniformity of the resulting electroplated film. Such control is exercised, for example, by placing the electroplating power provided to the individual anodes under the control of a programmable controller or the like. Adjustments to the electroplating power can thus be made subject to software control based on manual or automated inputs.

[0047] In the illustrated embodiment, anode **580** is effectively "seen" by microelectronic workpiece **25** as being positioned an approximate distance **A1** from the surface of microelectronic workpiece **25**. This is due to the fact that the relationship between the anode **580** and sidewall **560** creates a virtual anode having an effective area defined by the innermost dimensions of sidewall **560**. In contrast, anodes **585** are approximately at effective distances **A2**, **A3**, and **A4** proceeding from the innermost anode to the outermost anode, with the outermost anode being closest to the microelectronic workpiece **25**. All of the anodes **585** are in close proximity (i.e., about 25.4 mm or less, with the outermost anode being spaced from the microelectronic workpiece by about 10 mm) to the surface of the microelectronic workpiece **25** that is being electroplated. Since anodes **585** are in close proximity to the surface of the microelectronic workpiece **25**, they can be used to provide effective, localized control over the radial film growth at peripheral portions of the microelectronic workpiece. Such localized control is particularly desirable at the peripheral portions of the microelectronic workpiece since it is those portions that are more likely to have a high uniformity gradient (most often due to the fact that electrical contact is made with the seed layer of the microelectronic workpiece at the outermost peripheral regions resulting in higher plating rates at the periphery of the microelectronic workpiece compared to the central portions thereof).

[0048] The electroplating power provided to the foregoing anode arrangement can be readily controlled to accommodate a wide range of plating requirements without the need for a corresponding hardware modification. Some reasons for adjusting the electroplating power include changes to the following:

- [0049] a seed layer thickness;
- [0050] open area of plating surface (pattern wafers, edge exclusion);
- [0051] final plated thickness;
- [0052] plated film type (copper, platinum, seed layer enhancement);
- [0053] bath conductivity, metal concentration; and
- [0054] plating rate.

[0055] The foregoing anode arrangement is particularly well-suited for plating microelectronic workpieces having highly resistive seed layers as well as for plating highly resistive materials on microelectronic workpieces. Generally stated, the more resistive the seed layer or material that is to be deposited, the more the magnitude of the current at the central anode **580** (or central anodes) should be

increased to yield a uniform film. This effect can be understood in connection with an example and the set of corresponding graphs set forth in **FIGS. 10 and 11**.

[0056] **FIG. 10** is a graph of four different computer simulations reflecting the change in growth of an electroplated film versus the radial position across the surface of a microelectronic workpiece. The graph illustrates the changing growth that occurs when the current to a given one of the four anodes **580**, **585** is changed without a corresponding change in the current to the remaining anodes. In this illustration, Anode **1** corresponds to anode **580** and the remaining Anodes **2** through **4** correspond to anodes **585** proceeding from the interior most anode to the outermost anode. The peak plating for each anode occurs at a different radial position. Further, as can be seen from this graph, anode **580**, being effectively at the largest distance from the surface of the workpiece, has an effect over a substantial radial portion of the workpiece and thus has a broad affect over the surface area of the workpiece. In contrast, the remaining anodes have substantially more localized effects at the radial positions corresponding to the peaks of the graph of **FIG. 10**.

[0057] The differential radial effectiveness of the anodes **580**, **585** can be utilized to provide an effectively uniform electroplated film across the surface of the microelectronic workpiece. To this end, each of the anodes **580**, **585** may be provided with a fixed current that may differ from the current provided to the remaining anodes. These plating current differences can be provided to compensate for the increased plating that generally occurs at the radial position of the workpiece surface proximate the contacts of the cathode contact assembly **85** (**FIG. 1B**).

[0058] The computer simulated effect of a predetermined set of plating current differences on the normalized thickness of the electroplated film as a function of the radial position on the microelectronic workpiece over time is shown in **FIG. 11**. In this simulation, the seed layer was assumed to be uniform at **t0**. As illustrated, there is a substantial difference in the thickness over the radial position on the microelectronic workpiece during the initial portion of the electroplating process. This is generally characteristic of workpieces having seed layers that are highly resistive, such as those that are formed from a highly resistive material or that are very thin. However, as can be seen from **FIG. 11**, the differential plating that results from the differential current provided to the anodes **580**, **585** forms a substantially uniform plated film by the end of the electroplating process. It will be recognized that the particular currents that are to be provided to anodes **580**, **585** depends upon numerous factors including, but not necessarily limited to, the desired thickness and material of the electroplated film, the thickness and material of the initial seed layer, the distances between anodes **580**, **585** and the surface of the microelectronic workpiece, electrolyte bath properties, etc.

[0059] Anodes **580**, **585** may be consumable, but are preferably inert and formed from platinized titanium or some other inert conductive material. However, as noted above, inert anodes tend to evolve gases that can impair the uniformity of the plated film. To reduce this problem, as well as to reduce the likelihood of the entry of bubbles into the main processing chamber **505**, processing base **37** includes several unique features. With respect to anode **580**, a small

fluid flow path forms a Venturi outlet **590** between the underside of anode **580** and the relatively lower pressure channel **540** (see **FIG. 2**). This results in a Venturi effect that causes the electroplating solution proximate the surfaces of anode **580** to be drawn away and, further, provides a suction flow (or recirculation flow) that affects the uniformity of the impinging flow at the central portion of the surface of the microelectronic workpiece.

[**0060**] The Venturi flow path **590** may be shielded to prevent any large bubbles originating from outside the chamber from rising through region **590**. Instead, such bubbles enter the bubble-trapping region of the antechamber **510**.

[**0061**] Similarly, electroplating solution sweeps across the surfaces of anodes **585** in a radial direction toward fluid outlet **572** to remove gas bubbles forming at their surfaces. Further, the radial components of the fluid flow at the surface of the microelectronic workpiece assist in sweeping gas bubbles therefrom.

[**0062**] There are numerous further processing advantages with respect to the illustrated flow through the reactor chamber. As illustrated, the flow through the nozzles **535** is directed away from the microelectronic workpiece surface and, as such, there are no jets of fluid created to disturb the uniformity of the diffusion layer. Although the diffusion layer may not be perfectly uniform, it will be substantially uniform, and any non-uniformity will be relatively gradual as a result. Further, the effect of any minor non-uniformity may be substantially reduced by rotating the microelectronic workpiece during processing. A further advantage relates to the flow at the bottom of the main chamber **505** that is produced by the Venturi outlet, which influences the flow at the centerline thereof. The centerline flow velocity is otherwise difficult to implement and control. However, the strength of the Venturi flow provides a non-intrusive design variable that may be used to affect this aspect of the flow.

[**0063**] As is also evident from the foregoing reactor design, the flow that is normal to the microelectronic workpiece has a slightly greater magnitude near the center of the microelectronic workpiece and creates a dome-shaped meniscus whenever the microelectronic workpiece is not present (i.e., before the microelectronic workpiece is lowered into the fluid). The dome-shaped meniscus assists in minimizing bubble entrapment as the microelectronic workpiece or other workpiece is lowered into the processing solution (here, the electroplating solution).

[**0064**] A still further advantage of the foregoing reactor design is that it assists in preventing bubbles that find their way to the chamber inlet from reaching the microelectronic workpiece. To this end, the flow pattern is such that the solution travels downward just before entering the main chamber. As such, bubbles remain in the antechamber and escape through holes at the top thereof. Further, the upward sloping inlet path (see **FIG. 5** and appertaining description) to the antechamber prevents bubbles from entering the main chamber through the Venturi flow path.

[**0065**] **FIGS. 3-5** illustrate a specific construction of a complete processing chamber assembly **610** that has been specifically adapted for electrochemical processing of a semiconductor microelectronic workpiece. More particularly, the illustrated embodiment is specifically adapted for

depositing a uniform layer of material on the surface of the workpiece using electroplating.

[**0066**] As illustrated, the processing base **37** shown in **FIG. 1B** is comprised of processing chamber assembly **610** along with a corresponding exterior cup **605**. Processing chamber assembly **610** is disposed within exterior cup **605** to allow exterior cup **605** to receive spent processing fluid that overflows from the processing chamber assembly **610**. A flange **615** extends about the assembly **610** for securement with, for example, the frame of the corresponding tool.

[**0067**] With particular reference to **FIGS. 4 and 5**, the flange of the exterior cup **605** is formed to engage or otherwise accept rotor assembly **75** of reactor head **30** (shown in **FIG. 1B**) and allow contact between the microelectronic workpiece **25** and the processing solution, such as electroplating solution, in the main fluid flow chamber **505**. The exterior cup **605** also includes a main cylindrical housing **625** into which a drain cup member **627** is disposed. The drain cup member **627** includes an outer surface having channels **629** that, together with the interior wall of main cylindrical housing **625**, form one or more helical flow chambers **640** that serve as an outlet for the processing solution. Processing fluid overflowing a weir member **739** at the top of processing cup **35** drains through the helical flow chambers **640** and exits an outlet (not illustrated) where it is either disposed of or replenished and re-circulated. This configuration is particularly suitable for systems that include fluid re-circulation since it assists in reducing the mixing of gases with the processing solution thereby further reducing the likelihood that gas bubbles will interfere with the uniformity of the diffusion layer at the workpiece surface.

[**0068**] In the illustrated embodiment, antechamber **510** is defined by the walls of a plurality of separate components. More particularly, antechamber **510** is defined by the interior walls of drain cup member **627**, an anode support member **697**, the interior and exterior walls of a mid-chamber member **690**, and the exterior walls of flow diffuser **525**.

[**0069**] **FIGS. 3B and 4** illustrate the manner in which the foregoing components are brought together to form the reactor. To this end, the mid-chamber member **690** is disposed interior of the drain cup member **627** and includes a plurality of leg supports **692** that sit upon a bottom wall thereof. The anode support member **697** includes an outer wall that engages a flange that is disposed about the interior of drain cup member **627**. The anode support member **697** also includes a channel **705** that sits upon and engages an upper portion of flow diffuser **525**, and a further channel **710** that sits upon and engages an upper rim of nozzle assembly **530**. Mid-chamber member **690** also includes a centrally disposed receptacle **715** that is dimensioned to accept the lower portion of nozzle assembly **530**. Likewise, an annular channel **725** is disposed radially exterior of the annular receptacle **715** to engage a lower portion of flow diffuser **525**.

[**0070**] In the illustrated embodiment, the flow diffuser **525** is formed as a single piece and includes a plurality of vertically oriented slots **670**. Similarly, the nozzle assembly **530** is formed as a single piece and includes a plurality of horizontally oriented slots that constitute the nozzles **535**.

[**0071**] The anode support member **697** includes a plurality of annular grooves that are dimensioned to accept corre-

sponding annular anode assemblies **785**. Each anode assembly **785** includes an anode **585** (preferably formed from platinized titanium or another inert metal) and a conduit **730** extending from a central portion of the anode **585** through which a metal conductor may be disposed to electrically connect the anode **585** of each assembly **785** to an external source of electrical power. Conduit **730** is shown to extend entirely through the processing chamber assembly **610** and is secured at the bottom thereof by a respective fitting **733**. In this manner, anode assemblies **785** effectively urge the anode support member **697** downward to clamp the flow diffuser **525**, nozzle assembly **530**, mid-chamber member **690**, and drain cup member **627** against the bottom portion **737** of the exterior cup **605**. This allows for easy assembly and disassembly of the processing chamber **610**. However, it will be recognized that other means may be used to secure the chamber elements together as well as to conduct the necessary electrical power to the anodes.

[0072] The illustrated embodiment also includes a weir member **739** that detachably snaps or otherwise easily secures to the upper exterior portion of anode support member **697**. As shown, weir member **739** includes a rim **742** that forms a weir over which the processing solution flows into the helical flow chamber **640**. Weir member **739** also includes a transversely extending flange **744** that extends radially inward and forms an electric field shield over all or portions of one or more of the anodes **585**. Since the weir member **739** may be easily removed and replaced, the processing chamber assembly **610** may be readily reconfigured and adapted to provide different electric field shapes. Such differing electrical field shapes are particularly useful in those instances in which the reactor must be configured to process more than one size or shape of a workpiece. Additionally, this allows the reactor to be configured to accommodate workpieces that are of the same size, but have different plating area requirements.

[0073] The anode support member **697**, with the anodes **585** in place, forms the contoured sidewall **560** and slanted sidewall **565** that is illustrated in FIG. 2. As noted above, the lower region of anode support member **697** is contoured to define the upper interior wall of antechamber **510** and preferably includes one or more gas outlets **665** that are disposed therethrough to allow gas bubbles to exit from the antechamber **510** to the exterior environment.

[0074] With particular reference to FIG. 5, fluid inlet **515** is defined by an inlet fluid guide, shown generally at **810**, that is secured to the floor of mid-chamber member **690** by one or more fasteners **815**. Inlet fluid guide **810** includes a plurality of open channels **817** that guide fluid received at fluid inlet **515** to an area beneath mid-chamber member **690**. Channels **817** of the illustrated embodiment are defined by upwardly angled walls **819**. Processing fluid exiting channels **817** flows therefrom to one or more further channels **821** that are likewise defined by walls that angle upward.

[0075] Central anode **580** includes an electrical connection rod **581** that proceeds to the exterior of the processing chamber assembly **610** through central apertures formed in nozzle assembly **530**, mid-chamber member **690** and inlet fluid guide **810**. The small Venturi flow path regions shown at **590** in FIG. 2 are formed in FIG. 5 by vertical channels **823** that proceed through drain cup member **690** and the bottom wall of nozzle member **530**. As illustrated, the fluid

inlet guide **810** and, specifically, the upwardly angled walls **819** extend radially beyond the shielded vertical channels **823** so that any bubbles entering the inlet proceed through the upward channels **821** rather than through the vertical channels **823**.

[0076] FIGS. 6-9 illustrate a further embodiment of an improved reactor chamber. The embodiment illustrated in these figures retains the advantageous electric field and flow characteristics of the foregoing reactor construction while concurrently being useful for situations in which anode/electrode isolation is desirable. Such situations include, but are not limited to, the following:

[0077] instances in which the electrochemical electroplating solution must pass over an electrode, such as an anode, at a high flow rate to be optimally effective;

[0078] instances in which one or more gases evolving from the electrochemical reactions at the anode surface must be removed in order to insure uniform electrochemical processing; and

[0079] instances in which consumable electrodes are used.

[0080] With reference to FIGS. 6 and 7, the reactor includes an electrochemical electroplating solution flow path into the innermost portion of the processing chamber that is very similar to the flow path of the embodiment illustrated in FIG. 2 and as implemented in the embodiment of the reactor chamber shown in FIGS. 3A through 5. As such, components that have similar functions are not further identified here for the sake of simplicity. Rather, only those portions of the reactor that significantly differ from the foregoing embodiment are identified and described below.

[0081] A significant distinction between the embodiments exists, however, in connection with the anode electrodes and the appertaining structures and fluid flow paths. More particularly, the reactor based **37** includes a plurality of ring-shaped anodes **1015**, **1020**, **1025** and **1030** that are concentrically disposed with respect to one another in respective anode chamber housings **1017**, **1022**, **1027** and **1032**. As shown, each anode **1015**, **1020**, **1025** and **1030** has a vertically oriented surface area that is greater than the surface area of the corresponding anodes shown in the foregoing embodiments. Four such anodes are employed in the disclosed embodiment, but a larger or smaller number of anodes may be used depending upon the electrochemical processing parameters and results that are desired. Each anode **1015**, **1020**, **1025** and **1030** is supported in the respective anode chamber housing **1017**, **1022**, **1027** and **1032** by at least one corresponding support/conductive member **1050** that extends through the bottom of the processing base **37** and terminates at an electrical connector **1055** for connection to an electrical power source.

[0082] In accordance with the disclosed embodiment, fluid flow to and through the three outer most chamber housings **1022**, **1027** and **1032** is provided from an inlet **1060** that is separate from inlet **515**, which supplies the fluid flow through an innermost chamber housing **1017**. As shown, fluid inlet **1060** provides electroplating solution to a manifold **1065** having a plurality of slots **1070** disposed in its exterior wall. Slots **1070** are in fluid communication with a plenum **1075** that includes a plurality of openings **1080**

through which the electroplating solution respectively enters the three anode chamber housings **1022**, **1027** and **1032**. Fluid entering the anode chamber housings **1017**, **1022**, **1027** and **1032** flows over at least one vertical surface and, preferably, both vertical surfaces of the respective anode **1015**, **1020**, **1025** and **1030**.

[**0083**] Each anode chamber housing **1017**, **1022**, **1027** and **1032** includes an upper outlet region that opens to a respective cup **1085**. Cups **1085**, as illustrated, are disposed in the reactor chamber so that they are concentric with one another. Each cup includes an upper rim **1090** that terminates at a predetermined height with respect to the other rims, with the rim of each cup terminating at a height that is vertically below the immediately adjacent outer concentric cup. Each of the three innermost cups further includes a substantially vertical exterior wall **1095** and a slanted interior wall **1200**. This wall construction creates a flow region **1205** in the interstitial region between concentrically disposed cups (excepting the innermost cup that has a contoured interior wall that defines the fluid flow region **1205** and than the outer most flow region **1205** associated with the outer most anode) that increases in area as the fluid flows upward toward the surface of the microelectronic workpiece under process. The increase in area effectively reduces the fluid flow velocity along the vertical fluid flow path, with the velocity being greater at a lower portion of the flow region **1205** when compared to the velocity of the fluid flow at the upper portion of the particular flow region.

[**0084**] The interstitial region between the rims of concentrically adjacent cups effectively defines the size and shape of each of a plurality of virtual nodes, each virtual anode being respectively associated with a corresponding anode disposed in its respective anode chamber housing. The size and shape of each virtual anode that is seen by the microelectronic workpiece under process is generally independent of the size and shape of the corresponding actual anode. As such, consumable anodes that vary in size and shape over time as they are used can be employed for anodes **1015**, **1020**, **1025** and **1030** without a corresponding change in the overall anode configuration is seen by the microelectronic workpiece under process. Further, given the deceleration experienced by the fluid flow as it proceeds vertically through flow regions **1205**, a high fluid flow velocity may be introduced across the vertical surfaces of the anodes **1015**, **1020**, **1025** and **1030** in the anode chamber housings **1022**, **1027** and **1032** while concurrently producing a very uniform fluid flow pattern radially across the surface of the microelectronic workpiece under process. Such a high fluid flow velocity across the vertical surfaces of the anodes **1015**, **1020**, **1025** and **1030**, as noted above, is desirable when using certain electrochemical electroplating solutions, such as electroplating fluids available from Atotech. Further, such high fluid flow velocities may be used to assist in removing some of the gas bubbles that form at the surface of the anodes, particularly inert anodes. To this end, each of the anode chamber housings **1017**, **1022**, **1027** and **1032** may be provided with one or more gas outlets (not illustrated) at the upper portion thereof to vent such gases.

[**0085**] Of further note, unlike the foregoing embodiment, element **1210** is a securement that is formed from a dielectric material. The securement **1210** is used to clamp a plurality of the structures forming reactor base **37** together. Although securement **1210** may be formed from a conductive material

so that it may function as an anode, the innermost anode seen by the microelectronic workpiece under process is preferably a virtual anode corresponding to the interior most anode **1015**.

[**0086**] **FIGS. 8 and 9** illustrate computer simulations of fluid flow velocity contours of a reactor constructed in accordance with the embodiment shown in **FIGS. 10 through 12**. In this embodiment, all of the anodes of the reactor base may be isolated from a flow of fluid through the anode chamber housings. To this end, **FIG. 8** illustrates the fluid flow velocity contours that occur when a flow of electroplating solution is provided through each of the anode chamber housings, while **FIG. 9** illustrates the fluid flow velocity contours that occur when there is no flow of electroplating solution provided through the anode chamber housings past the anodes. This latter condition can be accomplished in the reactor of by turning off the flow the flow from the second fluid flow inlet (described below) and may likewise be accomplished in the reactor of **FIGS. 6 and 7** by turning of the fluid flow through inlet **1060**. Such a condition may be desirable in those instances in which a flow of electroplating solution across the surface of the anodes is found to significantly reduce the organic additive concentration of the solution.

[**0087**] **FIG. 12** illustrates a variation of the reactor embodiment shown in **FIG. 7**. For the sake of simplicity, only the elements pertinent to the following discussion are provided with reference numerals.

[**0088**] This further embodiment employs a different structure for providing fluid flow to the anodes **1015**, **1020**, **1025** and **1030**. More particularly, the further embodiment employs an inlet member **2010** that serves as an inlet for the supply and distribution of the processing fluid to the anode chamber housings **1017**, **1022**, **1027** and **1032**.

[**0089**] With reference to **FIGS. 12 and 13**, the inlet member **2010** includes a hollow stem **2015** that may be used to provide a flow of electroplating fluid. The hollow stem **2015** terminates at a stepped hub **2020**. Stepped hub **2020** includes a plurality of steps **2025** that each include a groove dimensioned to receive and support a corresponding wall of the anode chamber housings. Processing fluid is directed into the anode chamber housings through a plurality of channels **2030** that proceed from a manifold area into the respective anode chamber housing.

[**0090**] This latter inlet arrangement assists in further electrically isolating anodes **1015**, **1020**, **1025** and **1030** from one another. Such electrical isolation occurs due to the increased resistance of the electrical flow path between the anodes. The increased resistance is a direct result of the increased length of the fluid flow paths that exist between the anode chamber housings.

[**0091**] The manner in which the electroplating power is supplied to the microelectronic workpiece at the peripheral edge thereof effects the overall film quality of the deposited metal. Some of the more desirable characteristics of a contact assembly used to provide such electroplating power include, for example, the following:

[**0092**] uniform distribution of electroplating power about the periphery of the microelectronic workpiece to maximize the uniformity of the deposited film;

[0093] consistent contact characteristics to insure wafer-to-wafer uniformity;

[0094] minimal intrusion of the contact assembly on the microelectronic workpiece periphery to maximize the available area for device production; and

[0095] minimal plating on the barrier layer about the microelectronic workpiece periphery to inhibit peeling and/or flaking.

[0096] To meet one or more of the foregoing characteristics, reactor assembly 20 preferably employs a contact assembly 85 that provides either a continuous electrical contact or a high number of discrete electrical contacts with the microelectronic workpiece 25. By providing a more continuous contact with the outer peripheral edges of the microelectronic workpiece 25, in this case around the outer circumference of the semiconductor wafer, a more uniform current is supplied to the microelectronic workpiece 25 that promotes more uniform current densities. The more uniform current densities enhance uniformity in the depth of the deposited material.

[0097] Contact assembly 85, in accordance with a preferred embodiment, includes contact members that provide minimal intrusion about the microelectronic workpiece periphery while concurrently providing consistent contact with the seed layer. Contact with the seed layer is enhanced by using a contact member structure that provides a wiping action against the seed layer as the microelectronic workpiece is brought into engagement with the contact assembly. This wiping action assists in removing any oxides at the seed layer surface thereby enhancing the electrical contact between the contact structure and the seed layer. As a result, uniformity of the current densities about the microelectronic workpiece periphery are increased and the resulting film is more uniform. Further, such consistency in the electrical contact facilitates greater consistency in the electroplating process from wafer-to-wafer thereby increasing wafer-to-wafer uniformity.

[0098] Contact assembly 85, as will be set forth in further detail below, also preferably includes one or more structures that provide a barrier, individually or in cooperation with other structures, that separates the contact/contacts, the peripheral edge portions and backside of the microelectronic workpiece 25 from the plating solution. This prevents the plating of metal onto the individual contacts and, further, assists in preventing any exposed portions of the barrier layer near the edge of the microelectronic workpiece 25 from being exposed to the electroplating environment. As a result, plating of the barrier layer and the appertaining potential for contamination due to flaking of any loosely adhered electroplated material is substantially limited. Exemplary contact assemblies suitable for use in the present system are illustrated in U.S. Ser. No. 09/113,723, while Jul. 10, 1998, entitled "PLATING APPARATUS WITH PLATING CONTACT WITH PERIPHERAL SEAL MEMBER", which is hereby incorporated by reference.

[0099] One or more of the foregoing reactor assemblies may be readily integrated in a processing tool that is capable of executing a plurality of processes on a workpiece, such as a semiconductor microelectronic workpiece. One such processing tool is the LT-210™ electroplating apparatus available from Semitool, Inc., of Kalispell, Mont. FIGS. 14 and 15 illustrate such integration.

[0100] The system of FIG. 14 includes a plurality of processing stations 1610. Preferably, these processing stations include one or more rinsing/drying stations and one or more electroplating stations (including one or more electroplating reactors such as the one above), although further immersion-chemical processing stations constructed in accordance with the of the present invention may also be employed. The system also preferably includes a thermal processing station, such as at 1615, that includes at least one thermal reactor that is adapted for rapid thermal processing (RTP).

[0101] The workpieces are transferred between the processing stations 1610 and the RTP station 1615 using one or more robotic transfer mechanisms 1620 that are disposed for linear movement along a central track 1625. One or more of the stations 1610 may also incorporate structures that are adapted for executing an in-situ rinse. Preferably, all of the processing stations as well as the robotic transfer mechanisms are disposed in a cabinet that is provided with filtered air at a positive pressure to thereby limit airborne contaminants that may reduce the effectiveness of the microelectronic workpiece processing.

[0102] FIG. 15 illustrates a further embodiment of a processing tool in which an RTP station 1635, located in portion 1630, that includes at least one thermal reactor, may be integrated in a tool set. Unlike the embodiment of FIG. 14, in this embodiment, at least one thermal reactor is serviced by a dedicated robotic mechanism 1640. The dedicated robotic mechanism 1640 accepts workpieces that are transferred to it by the robotic transfer mechanisms 1620. Transfer may take place through an intermediate staging door/area 1645. As such, it becomes possible to hygienically separate the RTP portion 1630 of the processing tool from other portions of the tool. Additionally, using such a construction, the illustrated annealing station may be implemented as a separate module that is attached to upgrade an existing tool set. It will be recognized that other types of processing stations may be located in portion 1630 in addition to or instead of RTP station 1635.

[0103] Numerous modifications may be made to the foregoing system without departing from the basic teachings thereof. Although the present invention has been described in substantial detail with reference to one or more specific embodiments, those of skill in the art will recognize that changes may be made thereto without departing from the scope and spirit of the invention as set forth herein.

We claim:

1. A processing container for electrochemically processing a microelectronic workpiece comprising:

a principal fluid flow chamber;

a plurality of concentric anodes disposed at different elevations in the principal fluid flow chamber so as to place the concentric anodes at different distances from a microelectronic workpiece under process.

2. A processing container as claimed in claim 1 wherein one or more of the plurality of concentric anodes is disposed in close proximity to the microelectronic workpiece under process.

3. A processing container as claimed in claim 1 wherein the plurality of concentric anodes are arranged at increasing distances from the microelectronic workpiece from an out-

ermost one of the plurality of concentric anodes to an innermost one of the plurality of concentric anodes.

4. A processing container as claimed in claim 1 wherein one or more of the plurality of concentric anodes is a virtual anode.

5. A processing container as claimed in claim 4 wherein the virtual anode comprises:

an anode chamber housing having a processing fluid inlet and a processing fluid outlet, the processing fluid outlet being disposed in close proximity to the microelectronic workpiece under process;

at least one conductive anode element disposed in the anode chamber housing.

6. A processing container as claimed in claim 4 wherein the at least one conductive anode element is formed from an inert material.

7. A processing container as claimed in claim 3 wherein one or more of the plurality of concentric anodes is a virtual anode.

8. A processing container as claimed in claim 7 wherein the virtual anode comprises:

an anode chamber housing having a processing fluid inlet and a processing fluid outlet, the processing fluid outlet being disposed in close proximity to the microelectronic workpiece under process;

at least one conductive anode element disposed in the anode chamber housing.

9. A processing container as claimed in claim 8 wherein the at least one conductive anode element is formed from an inert material.

10. A processing container as claimed in claim 1 and further comprising a plurality of nozzles disposed to provide a flow of the electrochemical processing fluid to the principal fluid flow chamber, the plurality of nozzles being arranged and directed to provide vertical and radial fluid flow components that combine to generate a substantially uniform normal flow component radially across the at least one surface of the workpiece;

11. A processing container as claimed in claim 1 wherein the principal fluid flow chamber is defined at an upper portion thereof by an angled wall, the angled wall supporting one or more of the plurality of concentric anodes.

12. A processing container as claimed in claim 3 wherein the principal fluid flow chamber is defined at an upper portion thereof by an angled wall, the angled wall supporting one or more of the plurality of concentric anodes.

13. A processing container as claimed in claim 3 wherein the principal fluid flow chamber further comprises an inlet disposed at a lower portion thereof that is configured to provide a Venturi effect that facilitates recirculation of processing fluid flow in a lower portion of the principal fluid flow chamber.

14. A reactor for electrochemically processing at least one surface of a microelectronic workpiece, the reactor comprising:

a reactor head including a workpiece support;

one or more electrical contacts disposed on the workpiece support and positioned thereon to make electrical contact with the microelectronic workpiece;

a processing container including a plurality of nozzles angularly disposed in a sidewall of a principal fluid

flow chamber at a level within the principal fluid flow chamber below a surface of a bath of processing fluid normally contained therein during electrochemical processing;

a plurality of anodes disposed at different elevations in the principal fluid flow chamber so as to place the concentric anodes at different distances from a microelectronic workpiece under process without an intermediate diffuser between the plurality of anodes and the microelectronic workpiece under process.

15. A reactor as claimed in claim 14 wherein the plurality of nozzles are arranged and directed to provide vertical and radial fluid flow components that combine to generate a substantially uniform normal flow component radially across the at least one surface of the workpiece;

16. A reactor as claimed in claim 14 wherein one or more of the plurality of anodes is in close proximity to the workpiece under process.

17. A reactor as claimed in claim 14 wherein one or more of the plurality of concentric anodes is a virtual anode.

18. A reactor as claimed in claim 17 wherein the virtual anode comprises:

an anode chamber housing having a processing fluid inlet and a processing fluid outlet, the processing fluid outlet being disposed in close proximity to the microelectronic workpiece under process;

at least one conductive anode element disposed in the anode chamber housing.

19. A reactor as claimed in claim 18 wherein the at least one conductive anode element is formed from an inert material.

20. A reactor as claimed in claim 14 wherein the processing container is defined at an upper portion thereof by an angled wall, at least one of the plurality of anodes being supported by the angled wall.

21. A reactor as claimed in claim 14 and further comprising a rotor connected to rotate the workpiece support and an associated microelectronic workpiece at least during processing of the microelectronic workpiece.

22. A reactor as claimed in claim 14 and further comprising a plurality of nozzles angularly disposed in one or more sidewalls of the principal fluid flow chamber at a level within the principal fluid flow chamber below a surface of a bath of processing fluid contained therein during immersion processing.

23. A method for electroplating a material on a microelectronic workpiece comprising the steps of:

introducing at least one surface of the microelectronic workpiece into an electroplating bath;

providing a plurality of anodes in the electroplating bath, the plurality of anodes being spaced at different distances from the at least one surface of the microelectronic workpiece that is to be electroplated;

inducing an electrical current between each of the plurality of anodes and the at least one surface of the microelectronic workpiece.

24. A method as claimed in claim 23 wherein each of the plurality of anodes is provided with a fixed electrical current over a substantial portion of the electroplating process.

25. A method as claimed in claim 23 and further comprising the step of providing a substantially uniform normal

flow of electroplating solution to the at least one surface of the microelectronic workpiece.

26. A method as claimed in claim 23 and further comprising the step of providing a substantially uniform normal flow of electroplating solution to the at least one surface of

the microelectronic workpiece without an intermediate diffuser disposed between the plurality of anodes and the at least one surface of the microelectronic workpiece.

* * * * *