

[72] Inventors **Wesley E. Buford**
Covina;
Charles G. Buford, Azusa, both of, Calif.
 [21] Appl. No. **794,164**
 [22] Filed **Jan. 27, 1969**
 [45] Patented **July 27, 1971**
 [73] Assignee **Rayford Industries, Inc.**
Covina, Calif.

2,681,752 6/1954 Jarrett et al..... 222/511 X
 3,263,875 8/1966 Lofdahl..... 222/518
 3,434,631 3/1969 Merchlowitz..... 222/213

Primary Examiner—Robert B. Reeves
Assistant Examiner—Frederick R. Handren
Attorney—Miketta, Glenn, Poms and Smith

[54] **FLUID-DISPENSING VALVE**
2 Claims, 7 Drawing Figs.

[52] U.S. Cl..... **222/213,**
 222/511, 251/342
 [51] Int. Cl..... **B67d 3/00,**
 F16k 31/00
 [50] Field of Search..... 222/212,
 213, 518, 559, 511; 251/342

[56] **References Cited**
UNITED STATES PATENTS
 549,678 11/1895 Miller..... 222/518 UX

ABSTRACT: A self-closing, two part fluid-dispensing valve comprising an integral molded generally cup-shaped valve body member providing a valve chamber with an outlet opening. The wall of the valve body member includes a resilient portion which carries a connector means extending into the chamber for supporting a valve member having a valve skirt with surfaces sealingly engaging surfaces on the valve body member. The valve member includes a ported transverse wall which permits fluid communication between the main valve chamber and a valve chamber portion lying between the valve member and the resilient wall portion; the valve skirt being normally biased into closing relationship with respect to the outlet opening and the biasing force of the resilient wall portion being augmented by the fluid pressure head acting upon the internal surface of the resilient wall portion.

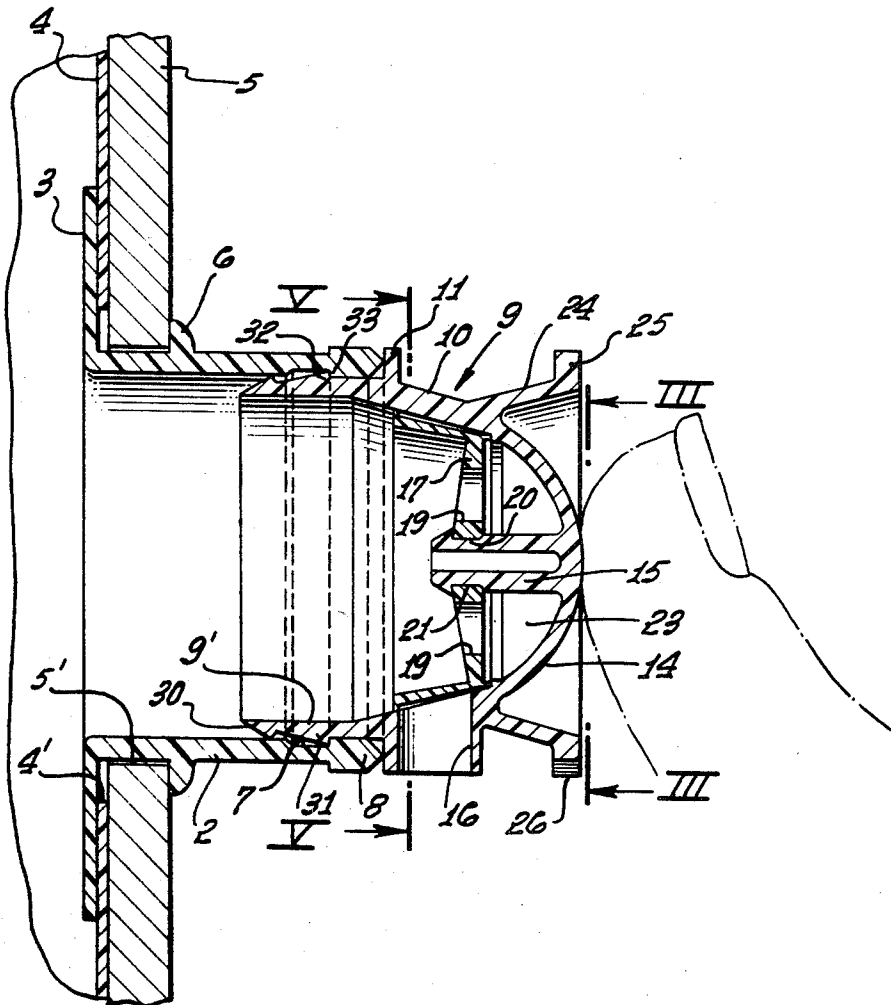

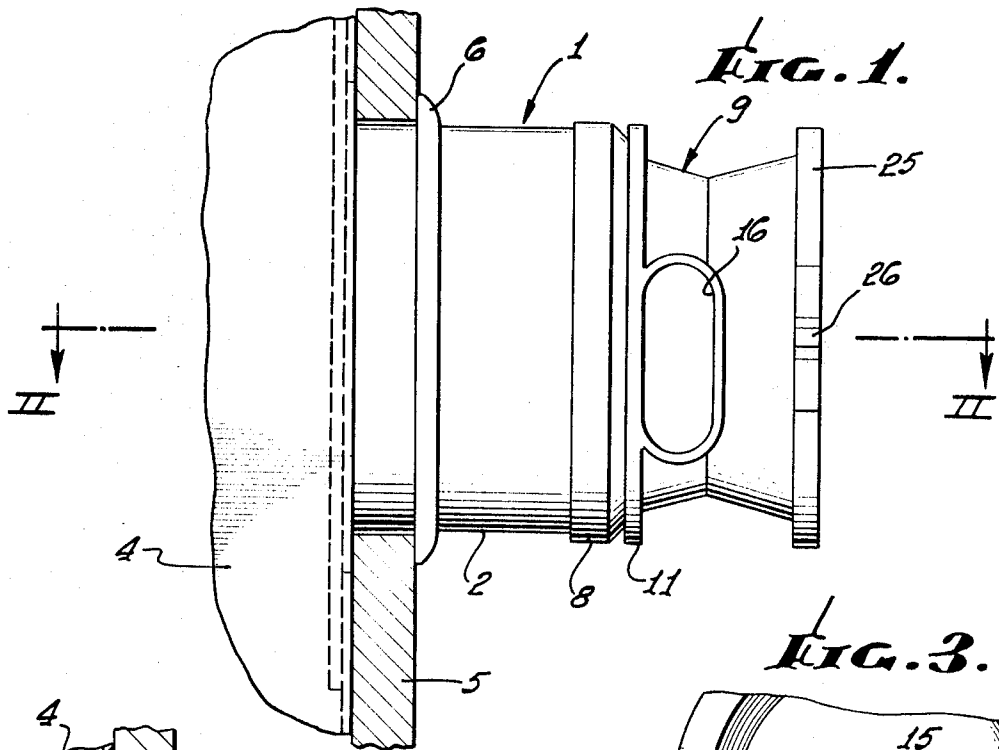

FIG. 1.

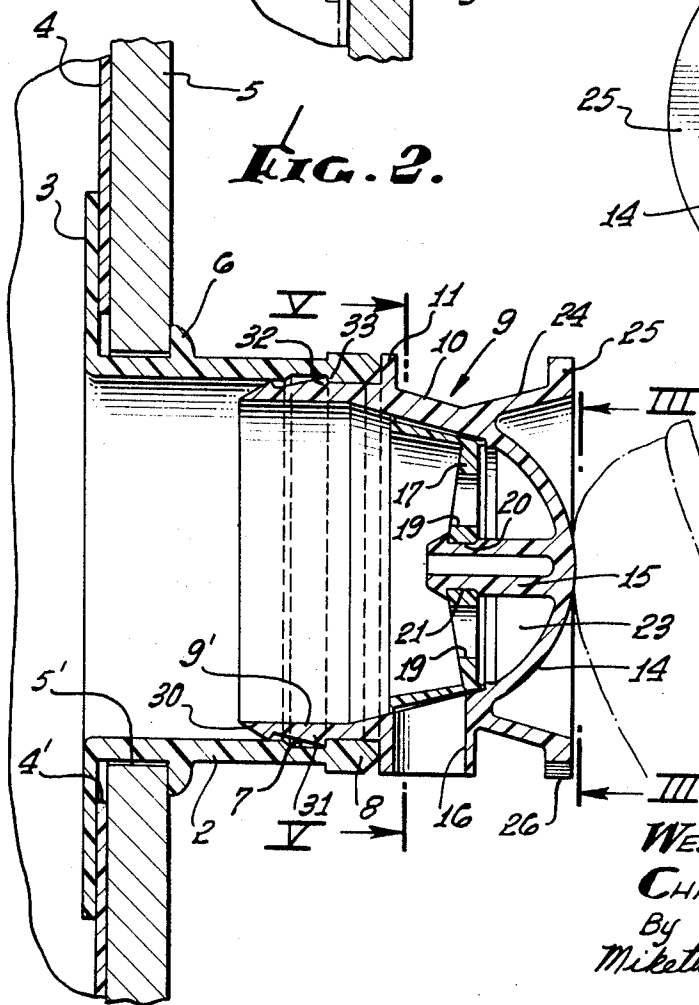

FIG. 2.

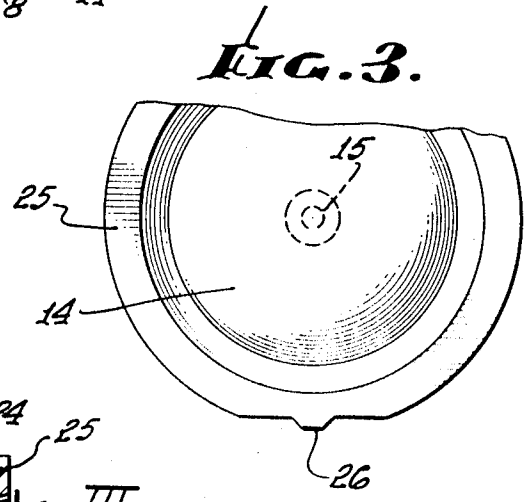

FIG. 3.

INVENTORS.
WESLEY E. BUFORD
CHARLES G. BUFORD
By
Mikette, Glenn, Pone & Smith
ATTORNEYS.

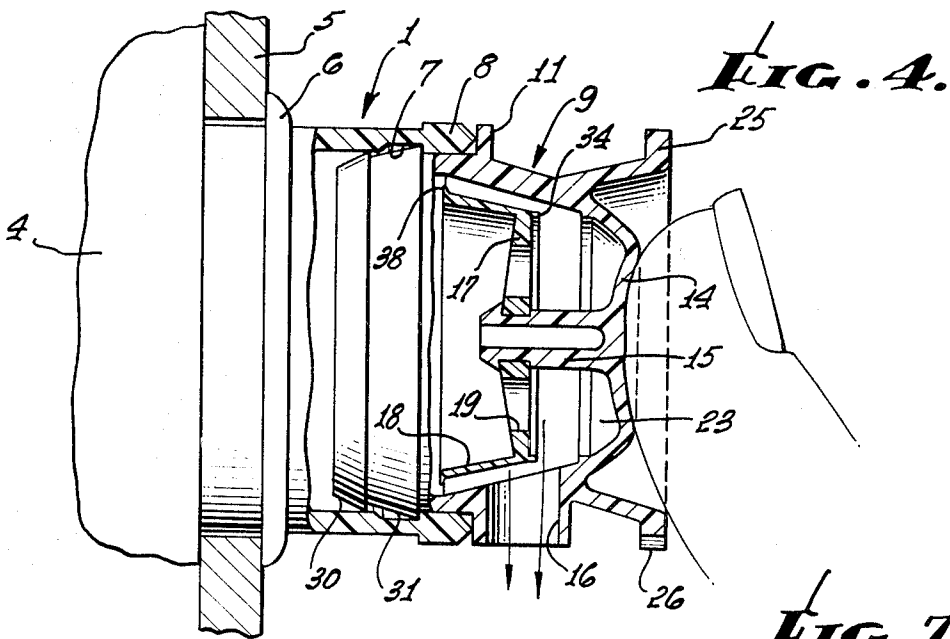

FIG. 6.

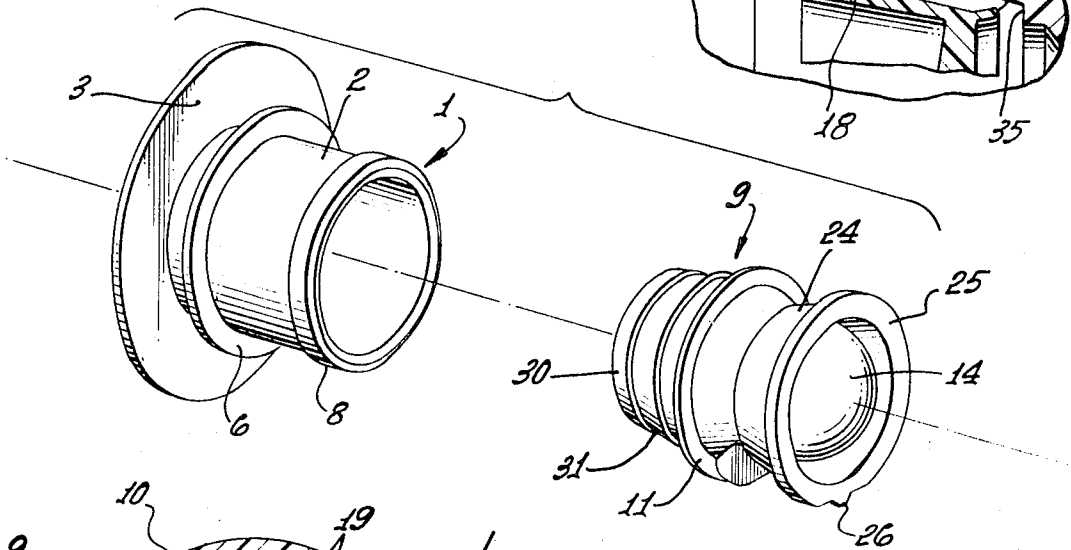
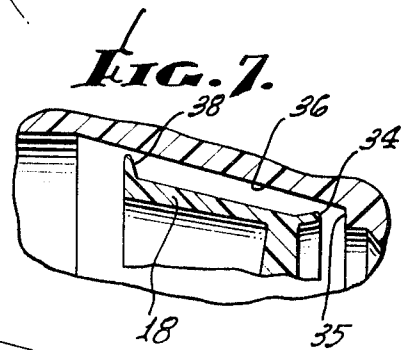

FIG. 5.

INVENTORS.
WESLEY E. BUFORD
CHARLES G. BUFORD
By

Miketta, Penny, Poma & Smith
ATTORNEYS.

FLUID-DISPENSING VALVE

BACKGROUND OF THE INVENTION

Heretofore liquids of various kinds have been packaged in containers of various sizes which have been opened by removing a cap closure, piercing the container wall, or by installing a spigot valve in the container wall. When smaller type liquid containers were used for perishable or activated liquids and all of the liquid contents were not used upon opening the container, the cap closure was replaced or a separate sealing closure was applied to the opening for reserving the liquid. An example is the dispensing of milk in the home, the milk container being closed and returned to the refrigerator.

Within the last few years, milk has become available in ten quart (2½gallon) containers which include a flexible plastic bag supported and carried when filled with milk in a suitably treated rectangular cardboard box or container. Such a flexible bag is provided with a fitting to which a dispensing valve may be attached. Thus when a glass of milk is desired, it may be drawn from the container while on the refrigerator shelf by actuation of the dispensing valve.

In a prior proposed dispensing valve for similar milk containers, the valve is separable from the bag and container. When the container is empty and the valve detached therefrom the valve is cleaned and then used on the next milk container. Such prior proposed valves embodied a construction which tended to accumulate deposits of milk within the valve structure. The valve structure was relatively complicated and difficult to thoroughly reach and clean the internal surfaces of the valve. It was often applied to the next milk container without complete cleaning. Thus, such prior proposed valves increased the danger of contaminating the milk by producing undesirable bacteria since surfaces upon which deposits of milk might be retained and accumulated were continuously exposed to ambient air. Moreover, such prior proposed valves have been relatively expensive and complex to manufacture and were not considered to be disposable with an empty milk container.

The present invention contemplates an inexpensive molded, two part disposable plastic fluid-dispensing valve means which may be employed with plastic flexible bag-type milk containers as mentioned above and which may also be readily adapted for use in dispensing liquids and fluids from other types of fluid carrying containers. While the present valve is exemplarily described in connection with a milk container, the invention contemplates a dispensing valve useful in dispensing various types of fluid such as water, motor and lubricant oils and petroleum products, liquid detergents for use in the home, laundromat, or commercial establishments, and various other installations where a quantity of bulk liquid is desired to be intermittently dispensed.

An object of the present invention is to disclose and provide a fluid-dispensing valve of novel construction and which is inexpensive and disposable with the container to which it may be attached.

Another object of the invention is to disclose and provide a fluid-dispensing valve rapidly and economically manufactured of plastic material and which essentially comprises two valve parts readily and quickly assembled into an operable dispensing valve and readily connected in fluidtight relation with a valve fitting on a container.

Another object of the present invention is to disclose and provide a fluid-dispensing valve wherein a resilient wall portion is connected to a valve member for maintaining the valve member in normally closed position and wherein the valve member includes a port providing communication of fluid to the resilient wall portion whereby fluid pressure assists the biasing force of the resilient wall portion for maintaining the valve member in closed position and providing a drip-free, nonleaking dispensing valve.

A further object of the invention is to disclose and provide a dispensing valve for liquids wherein a valve member and

discharge outlet are so arranged that closing of the valve after dispensing a selected quantity of liquid is positive and drip-free. A specific object of the invention is to provide a novel valve member having a conical wall or skirt provided with spaced sealing lips, one at the waist and the other at the free edge of the skirt for providing a positive reliable seal against dripping of fluid over shelf life periods.

A still further object of the invention is to disclose and provide a fluid-dispensing valve wherein a valve body member is provided with a resilient actuatable wall portion recessed within a protective flange to prevent accidental actuation of the dispensing valve.

Various other objects and advantages of the present invention will be readily apparent from the following description of the drawings in which an exemplary embodiment of the invention is shown.

IN THE DRAWINGS:

FIG. 1 is a bottom view of a valve means of this invention in conjunction with a plastic bag and container;

FIG. 2 is a cross-sectional view taken in a plane indicated by lines II-II of FIG. 1;

FIG. 3 is a fragmentary front view taken in the plane indicated by line III-III of FIG. 2;

FIG. 4 is a view similar to FIG. 2 except with a resilient pressure wall manually depressed;

FIG. 5 is a transversal sectional view taken in the plane indicated by line V-V of FIG. 2; and

FIG. 6 is a perspective view of a valve fitting and the valve means of this invention which snap fits into this valve fitting;

FIG. 7 is an enlarged fragmentary sectional view taken in a plane similar to that indicated by line II-II of FIG. 1.

Referring to FIGS. 1 through 6 inclusive, an exemplary valve fitting 1 may be made of readily moldable synthetic plastic unaffected by liquids which are to come in contact therewith.

The valve fitting preferably has a cylindrical wall 2 provided with an outwardly extending end flange 3 capable of insertion through a port 4' at or near one end of a plastic bag 4. The marginal portions of the inner surface of the bag are normally heat sealed to the flange 3. The folded or otherwise de-aired bag filled with milk as by a bag filling apparatus and method described in copending application, Ser. No. 424,610, now U.S. Pat. No. 3,403,826 may then be inserted in a rigid carton 5 which is preferably waxed or otherwise treated to be liquid-proof. Wall 2 of the fitting 1 is provided with a locking flange 6 spaced from the flange 3 to receive and hold marginal edge portions of the carton around a port 5' therein against flange 6 and bag 4 with a snap or pressure fit, which is facilitated by the tapered outer periphery of lock flange 6.

The outer end of wall 2 of the fitting is provided with an outwardly thickened end portion 8 and an annular groove 7 formed on the inner surface of wall 2, said groove performing a dual function as hereinafter described. It will be noted that the aforesaid fitting is readily attachable to a plastic bag, the bag and its fitting is easily inserted into and attached to a carton (the enlarged end 8 facilitating handling) and the bore of the fitting provides a smooth passage for liquids during filling and discharge.

Valve means 9 is also made of plastic composition and preferably comprises a forward cylindrical body portion 9' provided with a smooth bore. The outer surface of portion 9' is provided with a pair of circumferential locking wedge surfaces 30, 31 providing rearwardly and outwardly inclined conical surfaces which facilitate the insertion of the body portion 9' into the bore of the fitting, and at least one rearwardly facing locking shoulder 32 which is adapted to engage the opposed radial wall 33 of groove 7 on the internal surface of fitting 1 to hold valve means 9 therein, said conical wedge surface 31 and locking shoulder 32 forming a ridge of slightly greater diameter than the bore of the fitting 1. The groove 7 provides limited flexibility of the end of the fitting and

cooperates with the stop shoulder formed by end portion 8 to provide a positive lock. Valve means 9 is also provided with an outstanding annular flange 11 which abuts end portion 8 when the valve means is connected to the fitting.

Body portion 10 of the valve means has a relatively thick and rigid wall 36 which is provided with a frustoconical internal surface, and which merges into a generally hemispherical, relatively thin, resilient, flexible, pressure wall portion 14 having an inwardly and axially extending connector stem or projection 15. The inner end of projection 15 is closed and its outer surface is provided with a circumferential groove 20.

A cup-shaped valve sealing member having skirt or conical sidewall 18 and a perforated bottom wall 17, is connected with the pressure wall 14 by securement to the end of projection 15, grooved end of projection 15 being forced into an axial aperture 21 in bottom wall 17 and held thereon by the groove 20. Other means may be employed for attaching the valve member to the inner end of projection 15, such as by spot heat sealing wall 17 to the projection end.

Means to effect drip-free sealing by said valve member for duration of a shelflike period includes an axially and outwardly directed sealing lip 34 extending beyond the outer face of perforated wall 17 and adapted to seat and press its lip edge in the angle formed by wall 36 and an annular opposed internal shoulder 35 adjacent to the beginning of flexible wall portion 14. Longitudinally spaced from lip 34 is a second annular sealing lip 38 extending substantially radially outwardly from the free circumferential edge of skirt 18. Lip 38 sealingly wipes against the internal surface of wall 36 as the valve member moves into the final stages of closing. The cross section of wall 18 (FIG. 7) is tapered with its thinnest section adjacent the juncture with wall 17 for permitting some flexibility and slight hinging of wall 18. In valve closed position fluid pressure acting against the internal surface of wall 18 urges the wall against the opposed surface of the valve body and flexes the lip seal 38 into a tight seal against the body surface.

One side of body portion 10 is provided with a discharge outlet opening or spout 16. Conical sidewall 18 of the sealing member normally covers and seals the discharge spout, since the resilient pressure wall portion exerts a sealing force upon the sealing member through the tubular integral projection 15. When the pressure wall is depressed, the valve sealing member is moved inwardly to space the conical sidewall 18 from the body portion and to provide an annular space for flow of liquid to the discharge spout or outlet opening. A plurality of perforations or openings 19 in bottom wall 17 of the sealing member provide main flow passageways for liquids from the bag as well as providing fluid on opposite sides of the wall to facilitate opening and closing of the valve member.

When the pressure wall is released, the resiliency of the wall moves the valve member to closed position. The perforations 19 permit fluid communication between opposite sides of the wall and thus there is no fluid resistance to closing. Moreover, the pressure area of the valve member exposed to main valve chamber is greater than that area exposed to fluid adjacent the pressure wall and thus the fluid pressure head acting on the valve member and pressure wall tends to assist and maintain closing of the valve member.

In order to protect the valve means against accidental depression of the pressure wall during stacking of filled cartons provided with the device of this invention, a protective outwardly directed and flared skirt 24 is carried by the body portion 10 of the valve means 9, and said skirt terminating at a plane at or slightly beyond the outermost portion of pressure wall 14. Annular flange 25 of this protective skirt may be provided with an integral formed indicia 26 to indicate the location of pouring spout 16. The means for connecting the fitting and the valve means permit the valve means to be rotated with respect to the fitting and carton and to direct the discharge spout in any convenient position relative to the carton.

It is to be noted that the two main parts of the valve means can be made by relatively simple injecting molding, the resilient pressure wall as well as the means interconnecting it to the valve-sealing member being integral with the valve means. The resiliency, strength and flexibility of a plastic com-

position is utilized most effectively by the preferred construction. Assembly is accomplished very easily and surely. By the use of tapered, conical sealing surfaces, the valve means is positive, self-sealing, dripproof and leakproof. In use the main flow of liquid is through chamber 23 and the conical interior surface of the valve body is maintained clean.

Hence, a simply constructed two part plastic valve means is provided for a container for discharging fluid therefrom and for maintaining valve surfaces in contact with fluid clean at the same time, thereby also preventing the establishment of any unsanitary conditions, such as growth and collection of bacteria within the valve means. It should be noted that assembly of the valve means with the fitting is extremely simple and manually accomplished substantially without any tools. The valve fitting is normally attached to the plastic bag and upon filling of this bag, the valve means is simply snap fitted into the fitting thereby making assembly of the valve and the entire combination of valve, plastic bag and carton container in which the fluid is contained, very simple, inexpensive, sanitary, and reliable.

It should be also noted that the outlet opening 16 is provided in the valve sealing surface of the valve body and that valve skirt 18 spans or bridges the opening in closed position and the surfaces of spout or opening 16 are not only vertically disposed, but are also of little area. Thus, fluid rapidly and immediately drains therefrom upon valve closing and the valve is substantially drip-free.

Various modifications of the valve construction described above may be made within the spirit of this invention and all such changes coming within the scope of the appended claims are embraced thereby.

We claim:

1. A fluid-dispensing valve means, comprising:

a hollow valve body member having an integral body wall providing a valve chamber closed at one end and an opening for entry of fluid therein;

said wall being provided with a valve-sealing surface and an outlet opening;

said wall including a resilient wall portion having a connector means thereon extending into said chamber, and a valve-sealing member carried by said connector means in spaced relation to said resilient wall portion and defining a valve chamber portion,

said valve-sealing member having a skirt having a sealing surface movable into sealing engagement with the sealing surface on said wall for stopping flow of fluid from the valve chamber and chamber portion through the outlet opening;

said valve-sealing member having a valve wall carrying said skirt and having ports in said valve wall for fluid communication therethrough.

2. A fluid-dispensing valve means, comprising:

a hollow valve body member having an integral body wall providing a valve chamber closed at one end and an opening for entry of fluid therein;

said wall being provided with a valve-sealing surface and an outlet opening;

said wall including a resilient wall portion having a connector means thereon extending into said chamber, and a valve-sealing member carried by said connector means in spaced relation to said resilient wall portion and defining a valve chamber portion,

said valve-sealing member having a skirt having a sealing surface movable into sealing engagement with the sealing surface on said wall for stopping flow of fluid from the valve chamber and chamber portion through the outlet opening;

said valve-sealing member including means providing fluid communication between said valve chamber portion adjacent the resilient wall portion and the remainder of the valve chamber;

said means providing fluid communication between said valve chamber portion adjacent to the resilient wall portion and the remainder of the valve chamber comprising a ported transverse wall integral with said valve skirt.