

(19) World Intellectual Property Organization
International Bureau



(43) International Publication Date
3 July 2003 (03.07.2003)

PCT

(10) International Publication Number
WO 03/053288 A1

- (51) International Patent Classification⁷: **A61F 2/06**
- (21) International Application Number: PCT/US02/41338
- (22) International Filing Date:
20 December 2002 (20.12.2002)
- (25) Filing Language: English
- (26) Publication Language: English
- (30) Priority Data:
10/029,559 20 December 2001 (20.12.2001) US
10/091,641 5 March 2002 (05.03.2002) US
- (71) Applicant (for all designated States except US): **TRIVASCULAR, INC.** [US/US]; 3660 North Laughlin Road, Santa Rosa, CA 95403 (US).
- (72) Inventors; and
- (75) Inventors/Applicants (for US only): **CHOBOTOV,**

Michael, V. [US/US]; 3805 Skyfarm Drive, Santa Rosa, CA 95404 (US). **GLYNN, Brian, A.** [US/US]; 3678 Rocky Knoll Way, Santa Rosa, CA 95404 (US). **KARI, Stuart, E.** [US/US]; 1267 Eagle Drive, Windsor, CA 95492 (US). **MARTHALER, John, M.** [US/US]; 2307 Gifford Court, Santa Rosa, CA 95403 (US). **WHIRLEY, Robert, G.** [US/US]; 3709 Paxton Place, Santa Rosa, CA 95404 (US). **ZACHARIAS, Isaac, J.** [US/US]; 1472A North Street, Santa Rosa, CA 95404 (US). **STEPHENS, W., Patrick** [US/US]; 3764 Spring Creek Drive, Santa Rosa, CA 95405 (US).

(74) Agents: **WONG, Craig, P.** et al.; Townsend and Townsend and Crew LLP, Two Embarcadero Center, 8th Floor, San Francisco, CA 94111-3834 (US).

(81) Designated States (national): AE, AG, AL, AM, AT, AU, AZ, BA, BB, BG, BR, BY, BZ, CA, CH, CN, CO, CR, CU, CZ, DE, DK, DM, DZ, EC, EE, ES, FI, GB, GD, GE, GH,

[Continued on next page]

(54) Title: **ADVANCED ENDOVASCULAR GRAFT**

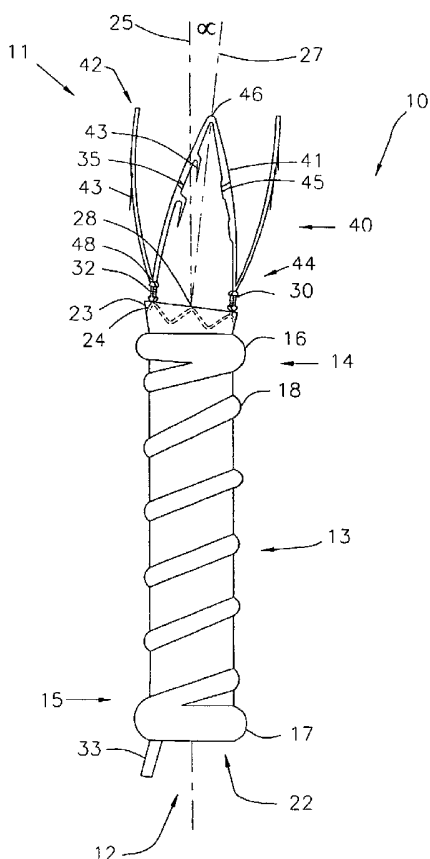

(57) Abstract: A system for the treatment of body passageways; in particular, vessels with vascular disease, the system includes an endovascular graft (10) with a low-profile delivery configuration and a deployed configuration in which it conforms to the morphology of the vessel or body passageway to be treated as well as various connector members (24) and stents (40). The graft (10) is made from an inflatable graft body section (13) and may be bifurcated. One or more inflatable cuffs (16) may be disposed at either end of the graft body section (13). At least one inflatable channel (22) is disposed between and in fluid communication with the inflatable cuffs (16).



WO 03/053288 A1



GM, HR, HU, ID, IL, IN, IS, JP, KE, KG, KP, KR, KZ, LC, LK, LR, LS, LT, LU, LV, MA, MD, MG, MK, MN, MW, MX, MZ, NO, NZ, OM, PH, PL, PT, RO, RU, SC, SD, SE, SG, SK, SL, TJ, TM, TN, TR, TT, TZ, UA, UG, US, UZ, VC, VN, YU, ZA, ZM, ZW.

(84) Designated States (regional): ARIPO patent (GH, GM, KE, LS, MW, MZ, SD, SL, SZ, TZ, UG, ZM, ZW), Eurasian patent (AM, AZ, BY, KG, KZ, MD, RU, TJ, TM), European patent (AT, BE, BG, CH, CY, CZ, DE, DK, EE, ES, FI, FR, GB, GR, IE, IT, LU, MC, NL, PT, SE, SI, SK, TR), OAPI patent (BF, BJ, CF, CG, CI, CM, GA, GN, GQ, GW, ML, MR, NE, SN, TD, TG).

Declaration under Rule 4.17:

— *of inventorship (Rule 4.17(iv)) for US only*

Published:

— *with international search report*

— *before the expiration of the time limit for amending the claims and to be republished in the event of receipt of amendments*

For two-letter codes and other abbreviations, refer to the "Guidance Notes on Codes and Abbreviations" appearing at the beginning of each regular issue of the PCT Gazette.

ADVANCED ENDOVASCULAR GRAFT

CROSS-REFERENCES TO RELATED APPLICATIONS

[0001] This application is a continuation-in-part of U.S. Patent Application Serial No. 10/091,641 entitled "Advanced Endovascular Graft," filed on March 5, 2002 by Chobotov et al., which is a continuation of U.S. Patent Application Serial No. 10/029,559
5 entitled "Advanced Endovascular Graft," filed on December 20, 2001 by Chobotov et al., the complete disclosures of which are incorporated herein by reference in their entirety.

[0002] This application is also related to U.S. Patent Application Serial No. 10/029,570 entitled "Method and Apparatus for Shape Forming Endovascular Graft Material"
10 by Chobotov et al., U.S. Patent Application Serial No. 10/029,584 entitled "Endovascular Graft Joint and Method for Manufacture" by Chobotov et al., U.S. Patent Application Serial No. 10/029,557 entitled "Method and Apparatus for Manufacturing an Endovascular Graft Section", by Chobotov et al. All of the above applications are commonly owned and were filed on December 20, 2001. All of the above applications are hereby incorporated herein by
15 reference, each in its entirety.

BACKGROUND OF THE INVENTION

[0003] The present invention relates to a system for the treatment of disorders of the vasculature. More specifically, the invention relates to a system for the treatment of disease or injury that potentially compromises the integrity of a flow conduit in the body. For
20 example, an embodiment of the invention is useful in treating indications in the digestive and reproductive systems as well as indications in the cardiovascular system, including thoracic and abdominal aortic aneurysms, arterial dissections (such as those caused by traumatic injury), etc. Such cardiovascular indications often require intervention due to the severity of the sequelae, which frequently is death.

[0004] For indications such as abdominal aortic aneurysms, traditional open
25 surgery is still the conventional and most widely-utilized treatment when the aneurysm's size has grown to the point that the risk of aneurysm rupture outweighs the drawbacks of surgery. Surgical repair involves replacement of the section of the vessel where the aneurysm has formed with a graft. An example of a surgical procedure is described by Cooley in Surgical
30 Treatment of Aortic Aneurysms, 1986 (W.B. Saunders Company).

[0005] Despite its advantages, however, open surgery is fraught with high morbidity and mortality rates, primarily because of the invasive and complex nature of the procedure. Complications associated with surgery include, for example, the possibility of aneurysm rupture, loss of function related to extended periods of restricted blood flow to the extremities, blood loss, myocardial infarction, congestive heart failure, arrhythmia, and complications associated with the use of general anesthesia and mechanical ventilation systems. In addition, the typical patient in need of aneurysm repair is older and in poor health, facts that significantly increase the likelihood of complications.

[0006] Due to the risks and complexities of surgical intervention, various attempts have been made to develop alternative methods for treating such disorders. One such method that has enjoyed some degree of success is the catheter-based delivery of a bifurcated stent-graft via the femoral arteries to exclude the aneurysm from within the aorta.

[0007] Endovascular repair of aortic aneurysms represents a promising and attractive alternative to conventional surgical repair techniques. The risk of medical complications is significantly reduced due to the less-invasive nature of the procedure. Recovery times are significantly reduced as well, which concomitantly diminishes the length and expense of hospital stays. For example, open surgery requires an average six-day hospital stay and one or more days in the intensive care unit. In contrast, endovascular repair typically requires a two-to-three day hospital stay. Once out of the hospital, patients benefiting from endovascular repair may fully recover in two weeks while surgical patients require six to eight weeks.

[0008] Despite these and other significant advantages, however, endovascular-based systems have a number of shortcomings. Present bifurcated stent-grafts require relatively large delivery catheters, often up to 24 French and greater in diameter. These catheters also tend to have a high bending stiffness. Such limitations result in the need for a surgical cut-down to deliver the stent-graft and make delivery through the often narrow and irregular arteries of diseased vessels difficult and risky. Because of this, endovascular treatment of aortic aneurysmal disease is not available to many patients who could otherwise benefit from it. For instance, women statistically tend to have smaller vessels and therefore some are excluded from many current endovascular therapies simply due to this reason. There is therefore a need for an endovascular stent-graft capable of being delivered via a smaller and more flexible delivery catheter. Even greater advantages may be realized if such an endovascular stent-graft is capable of being delivered percutaneously.

[0009] Further, an endovascular stent-graft must withstand tremendous pulsatile forces over a substantial period of time while remaining both seated and sealed within the vessel. In order to achieve these objectives, the device, which may comprise component parts and/or materials, must remain intact. The device must resist axial migration from the site of deployment while being subjected to significant pulsatile forces, and it should have sufficient radial compliance to conform to the vessel anatomy within which it is deployed so as to prevent blood leakage between the device and the vessel wall at both its proximal, or cephalic, end as well as at its distal, or caudal end or ends (where the net force may be retrograde). Such a device should conform to the morphology of the treated vessel, without kinking or twisting, over the life of the patient.

BRIEF SUMMARY OF THE INVENTION

[0010] The present invention generally is directed to methods and systems for the endovascular treatment of body passageways that includes the use of a medical device that is implantable within a body lumen, such as a blood vessel. Some embodiments of this invention include an endovascular graft for treating vascular disease.

[0011] One embodiment includes a graft with a graft body section having a proximal end and a distal end, and disposed or affixed on at least one end, a connector member having one or more connector member connector elements. The connector member may be embedded within multiple layers of the graft body section. A stent may be coupled or affixed to the one or more connector member connector elements via one or more stent connector elements. The graft may include a proximal stent and connector member only, a distal stent and connector member only, or both proximal and distal stents and their respective connector members.

[0012] Both the connector member connector elements and the stent connector elements may have a proximal end and a distal end that comprise opposing shoulder portions. The graft may further have one or more coupling members, such as a wire coil, configured to couple or connect the one or more connector member connector elements to the one or more stent connector elements.

[0013] The connector member may take the form of a serpentine ring having one or more apices. In other embodiments, the connector member may be a plurality of discrete connector member elements.

[0014] The discrete connector member elements may take a variety of shapes but should be designed to resist detachment from the graft under various loads (such as

traction loads). For example, one or more of the discrete connector member elements can take on a "V" or "T" shape, in any combination. Each of the discrete connector member elements should have at least one connector element. However, the number of connector elements that are coupled to each of the connector member elements depends on a variety of factors, including the connector member element shape and graft diameter.

[0015] Compared to a continuous ring connector member, using a plurality of discrete attachment connector member elements in the graft as described herein tends to reduce the amount of material in the graft proximal neck portion, allowing for a lower graft diameter profile. It also allows for a reduced proximal neck portion length, which can allow a larger range of AAA patients to be treated since a shorter aortic neck length between the distal renal artery and the aneurysm may be accommodated as described in greater detail below. If desired, the connector member elements may also be used on a distal neck portion of the graft and on at least one of the iliac limbs on any of the stent-graft described herein, in any combination with the aforementioned improvements.

[0016] One of the associated serpentine ring connector members may have twice as many apices as the stent. In another embodiment, the graft has two-stage distal and/or proximal stents with twice as many apices in a first region as in a second region while the associated connector member has the twice the number of apices as in the first region of the stent. For example, a useful embodiment is one in which a twelve-apex connector member is connected to a first six-apex or six-crown region of a proximal or distal stent and that stent has a second three-apex or three-crown region integral with or joined to the six-crown region. Another useful embodiment is one in which an eight-apex connector member (or a connector member having eight connector member elements) is connected to a first eight-apex or eight-crown region of a proximal stent and that stent has a second four-apex or four-crown region integral with or joined to the eight-crown region, while at least one distal stent has a five-apex or five-crown region is connected to a five-apex connector member (or a connector member having five connector member elements).

[0017] In alternative embodiments, grafts that include various combinations of single and multiple-stage proximal and distal stents with their associated connector members are possible.

[0018] The stents may also include one or more barbs. Typically, the barbs on a proximal stent are oriented distally to engage the stent into the tissue wall in the proximal-to-distal flow field in which the graft is typically disposed. Likewise, in applications in which the graft is deployed to treat an abdominal or thoracic aortic aneurysm, the barbs on

one or more distal stents are typically oriented proximally to engage the stent into the tissue wall to oppose the typically retrograde migration forces; however, one or more distal stents may also include one or more barbs oriented distally to resist periprocedural distal forces associated with delivery catheter and/or balloon manipulations, for example. The barbs may range in length from about 1 mm to about 5 mm. The barbs typically will project radially outward from a longitudinal axis of their respective stent and form a barb radial angle from about 10 degrees to about 45 degrees with respect to the graft proximal neck portion inlet axis when the stent is deployed *in vivo*. The barbs may also be laterally biased in a plane that is orthogonal to a plane in which the barb radial angle is formed to form a barb kick angle.

10 **[0019]** The stent or stents (proximal and/or distal) may comprise struts having one or more optional barb tuck pads integral to the struts such that when the proximal stent is in a reduced profile delivery configuration, each barb is retained by the stent strut. When the endovascular graft is in a deployed configuration, the one or more barbs are released.

15 **[0020]** The stent or stents may also comprise optional barb tuck slots configured to receive the barbs such that each barb is retained by a slot when the stent is in a delivery configuration. In a deployed configuration, the barbs are released from their corresponding barb tuck slots.

20 **[0021]** In addition, the stent or stents may comprise grooves. In a typical delivery system, some type of belts or sutures may be used to help retain the endovascular graft in its compressed delivery configuration. The grooves may accommodate these belts or sutures without increasing the small diameter delivery of the device, and also may provide secure location of the belts relative to the stent.

25 **[0022]** The graft body section may also have one or more inflatable cuffs disposed on or near the graft body section proximal end, distal end, or both. The inflatable cuffs provide a sufficiently stiff structure when inflated which help to support the graft body section and provide a conformable surface to seal the graft against the interior surface of the vessel in which it is deployed.

[0023] In some embodiments, the inflatable cuffs may be disposed in an axisymmetric cylindrical pattern around a proximal end and/or a distal end of the graft body.

30 **[0024]** In other embodiments, the proximal and distal sealing cuffs may take on a serrated configuration. Serrated inflatable cuffs have the advantage of not being as susceptible to compression folding so that the graft is less sensitive to changes in the diameter of the body lumen. The serrated inflatable cuffs may comprise a zigzag channel that defines a plurality of apices.

[0025] When inflated, the serrated inflatable cuffs of the present invention are less sensitive to in-folding that can be caused by diametric interference of the graft with the body lumen. In some configurations, the serrated inflatable cuffs may comprise varying radii in the serrations to further reduce the potential for undesirable in-folding.

5 [0026] The graft body section may also include one or more inflatable channels. The channel or channels typically may be disposed between and in fluid communication with either or both proximal and distal inflatable cuffs. The channel or channels enhance the graft body section stiffness upon their inflation, help to prevent kinking of the graft body section, and may also facilitate deployment of the graft within a patient's
10 body passageway. The inflatable channel or channels can be in a longitudinal and/or linear configuration with respect to the graft body section, but alternatively may take on a helical or circumferential configuration or some combination thereof. Other orientations such as interconnecting grids or rings may also be suitable alone or in combination with any of the other configurations.

15 [0027] The inflatable channels may also have a serrated pattern to provide kink resistance or folding resistance. The serrated inflatable channel may be disposed helically, circumferentially, in an annular rib and spine configuration, or the like. Kink resistance of such inflatable channels may be enhanced due to the ability of the serrations to hinge so as to prevent the formation of longitudinal folds. In some configurations, the
20 serrations may have differing inner and outer radii .

[0028] The channels that connect the adjacent inflatable channels (either serrated or non-serrated circumferential rings) may alternatively have a staggered or discontinuous longitudinal channel or spine to promote flexibility of the graft body or limb.

[0029] The endovascular graft may have one or more inflatable longitudinal
25 channels, or spines, and one or more circumferential inflatable channels, any of which may be designed to have the ability to shorten and lengthen to adjust for differences in the length and tortuosity of the patient's vessels or body lumens without unacceptable kinking. The longitudinal channel or spine may comprise one or more predetermined "kink spots" disposed, for example, between adjacent circumferential inflatable channels. The
30 longitudinal channel may be configured to kink one or more times between each circumferential inflatable channel, thus reducing the amount of intrusion of each kink into the graft lumen.

[0030] The longitudinal channel or spine that interconnects the inflatable channels (and proximal and distal cuffs) may also take on a nonlinear or wave-type

configuration so as to allow for improved compression in the graft longitudinal direction. Such a configuration may further reduce the potential for the graft to kink during foreshortening.

5 **[0031]** During deployment of the graft, the inflatable cuff or cuffs and channel or channels may be inflated or injected with a material that may comprise one or more of a solid, fluid (gas and/or liquid), gel or other medium. According to the invention, a useful inflation medium includes the combination polyethylene glycol diacrylate, pentaerythritol tetra 3(mercaptopropionate) and a buffer such as glycylglycine or triethanolamine in phosphate-buffered saline. Saline or another inert biocompatible liquid may be added to this
10 three-component inflation medium in amounts up to about sixty percent of the total inflation medium volume. Radiopaque materials such as tantalum, iodinated contrast agents, barium sulfate, etc. may be added to this three-component medium, typically in the buffer, so to render the inflation medium visible under fluoroscopy.

15 **[0032]** In another embodiment of the invention, the graft may comprise a main body portion and a first bifurcated portion forming a continuous lumen that is configured to confine a flow of fluid therethrough. The graft may also include a second bifurcated portion in fluid communication with the main body portion. At least one inflatable cuff may be disposed at either or both a proximal end of the main body portion and a distal end of the first bifurcated portion. One or more inflatable channels may be disposed between the inflatable
20 cuffs as previously described, and may extend over some or all of the main body portion. The cuffs and channels may be filled with an inflation medium, optionally diluted with an inert biocompatible material such as saline or other liquid, as described above.

25 **[0033]** In yet another embodiment of the invention, the graft may comprise a main body portion in fluid communication with a first and a second bifurcated portion forming a continuous bifurcated lumen, said lumen configured to confine a flow of fluid therethrough. At least one inflatable cuff may be disposed at or near either or both a proximal end of the main body portion and a distal end of the first and second bifurcated portions. One or more inflatable channels may be disposed between the inflatable cuffs as previously described, and may extend over some or all of the main body portion.

30 **[0034]** The proximal end of the graft main body portion may have connector members comprising one or more connector elements, and a proximal stent coupled to the one or more connector elements. One or both of the first and/or second bifurcated portions may likewise have first and/or second distal connector members comprising one or more

connector elements disposed on their respective distal ends, and a distal stent coupled to the first and/or second distal connector members.

5 [0035] The present invention is also a system for implanting a tubular medical device within a body lumen having a wall, including a stent for affixing the medical device to the body lumen wall and a connector member for coupling the stent to the medical device, wherein the stent and the connector member are coupled to one another by at least one set of connector elements.

10 [0036] One or more barbs may also be included in this system. In addition, one or more barb tuck pads may be included in which the one or more barbs are configured to be retained by the one or more barb tuck pads when the system is in a delivery configuration and released by the one or more barb tuck pads when the system moves to a deployed configuration. The stent may further include optional slots configured to receive the barbs when the system is in a delivery configuration and wherein the barbs are configured to be released from the slots when the system is in a deployed configuration.

15 [0037] The invention also includes an endovascular graft comprising a graft body section with a proximal end and a distal end and a proximal connector member affixed to the proximal end of the graft body section. The proximal connector member may have one or more connector elements.

20 [0038] The graft may also have a proximal stent comprising one or more distally oriented barbs and one or more proximal stent connector elements coupled to the one or more proximal connector member connector elements and a distal connector member affixed to the distal end of the graft body section. The distal connector member may include one or more connector elements.

25 [0039] The graft of this embodiment further includes a distal stent comprising one or more proximally or distally oriented barbs and comprising one or more distal stent connector elements coupled to the one or more distal connector member connector elements, one or more inflatable cuffs disposed at or near each of the proximal and distal ends of the graft body section, and wherein the graft body section comprises an inflatable channel in fluid communication with the proximal and distal cuffs.

30 [0040] In addition, the proximal and distal connector member connector elements may each have opposing shoulder portions on their proximal and distal ends, as may the proximal and distal stent connector elements. One or more coupling members may couple the proximal connector member connector elements to the proximal stent connector

elements and likewise couple the one or more distal connector member connector elements to the one or more distal stent connector elements.

5 [0041] At least one of the inflatable channel, the distal inflatable cuff, and the proximal inflatable cuff may contain an inflation medium comprising the combination polyethylene glycol diacrylate, pentaerythritol tetra 3(mercaptopropionate), and a buffer.

[0042] The proximal stent barbs or distal stent barbs of this embodiment may have a length from about 1 mm to about 5 mm, and the graft body section may comprise ePTFE.

10 [0043] In yet still a further bifurcated embodiment of the present invention, the device includes a main body portion with a distal end and a proximal end with a connector member disposed on the proximal end. The connector member may include one or more connector elements.

[0044] The proximal stent of this embodiment may comprise one or more distally oriented barbs and one or more proximal stent connector elements that are coupled to the connector member connector elements.

[0045] This embodiment further includes a first bifurcated portion and a second bifurcated portion forming a continuous lumen with the main body portion. This lumen is configured to confine a flow of fluid therethrough.

20 [0046] A distal connector member may be disposed on distal ends of each of the first and second bifurcated portions. Each of these distal connector members includes one or more connector elements. In addition, this embodiment has one or more distal stents with at least one proximally oriented barb and comprising one or more distal stent connector elements. The distal stent connector elements are coupled to the distal connector member connector elements on one or both of the first and second bifurcated portions.

25 [0047] This embodiment also includes at least one inflatable channel extending from one or both of the first and second bifurcated portions to the main body portion, at least one inflatable cuff disposed at or near a proximal end of the main body portion in fluid communication with the at least one channel, and an inflatable cuff disposed at or near a distal end of each of the first and second bifurcated portions.

30 [0048] The proximal and distal connector member connector elements may each have opposing shoulder portions on their proximal and distal ends, as may the proximal and distal stent connector elements. One or more coupling members may couple the proximal connector member connector elements to the proximal stent connector elements and

likewise couple the one or more distal connector member connector elements to the one or more distal stent connector elements.

[0049] At least one of the inflatable channel, the first bifurcated portion distal inflatable cuff, the second bifurcated portion distal inflatable cuff, and the proximal inflatable cuff may contain an inflation medium comprising the combination polyethylene glycol diacrylate, pentaerythritol tetra 3(mercaptopropionate), and a buffer.

[0050] The proximal and/or distal stent barbs may have a length from about 1 mm to about 5 mm. The graft main body portion as well as the first and second bifurcated portions may comprise ePTFE.

10 [0051] These and other advantages of the invention will become more apparent from the following detailed description of the invention when taken in conjunction with the accompanying exemplary drawings.

BRIEF DESCRIPTION OF THE DRAWINGS

[0052] FIG. 1 shows an endovascular graft according to an embodiment of the present invention.

[0053] FIGS. 1A-1B detail two angles at which a stent barb may be oriented on the graft of an embodiment of the present invention.

[0054] FIG. 2 shows a second endovascular graft according to an embodiment of the present invention.

20 [0055] FIG. 2A shows an endovascular graft having an optional serrated inflatable channel together with an optional staggered longitudinal channel or spine..

[0056] FIG. 2B illustrates an endovascular graft having a plurality of inflatable channels and a wavy or serpentine spine.

[0057] FIG. 3A shows a flat pattern of a component of the endovascular graft of FIG. 2.

[0058] FIG. 3B shows an embodiment of a connector member that comprises a plurality of discrete anchors and coupling elements.

[0059] FIG. 3C shows an individual anchor and coupling element of FIG. 3B.

[0060] FIG. 3D shows an embodiment of a connector member that comprises a plurality of discrete V-shaped connector member elements.

30 [0061] FIG. 4 shows a flat pattern of another component of the endovascular graft of FIG. 2.

[0062] FIG. 5 shows a flat pattern of a portion of the endovascular graft of FIG. 2.

[0063] FIG. 5A is an enlarged side view of FIG. 5 at Detail A.

[0064] FIG. 6 is an enlarged perspective view of a portion of an endovascular graft having features of an embodiment of the present invention.

[0065] FIG. 7 shows a bifurcated endovascular graft according to embodiments of the present invention.

[0066] FIGS. 7A-7B illustrate a section of graft exhibiting kinking between adjacent channels.

[0067] FIG. 7C-7D illustrates the kinking behavior of a section of a graft having predetermined kink points between adjacent channels.

[0068] FIG. 8 shows a flat pattern of yet another component of the endovascular graft of FIG. 2.

[0069] FIG. 9 shows a flat pattern of another component of the endovascular graft of FIG. 2.

[0070] FIG. 10 shows detail of a stent apex detail that comprises offset circular and elliptical radii.

[0071] FIG. 11 shows detail of a stent apex detail that comprises offset circular radii.

[0072] FIG. 12 shows detail of a stent section comprising a tapered strut section.

[0073] FIG. 13 shows detail of a stent section comprising another configuration for a tapered strut section.

[0074] FIG. 14 shows a two-stage stent embodiment of the present invention.

[0075] FIG. 15 shows another two-stage stent embodiment of the present invention.

[0076] FIG. 16A schematically illustrates a longitudinal cross-sectional of a portion of an idealized endovascular graft of the present invention in the vicinity of an inflatable cuff, comparing the graft portion diameter when the cuff is inflated in free space to the graft portion diameter when the cuff is disposed in a vessel or other body lumen.

[0077] FIG. 16B schematically illustrates a transverse cross section of the idealized graft portion of FIG. 16A along line A-A, demonstrating the possible creation of undesirable folds in the outer surface of the inflated cuff when the graft is disposed in a vessel or other body lumen compared to the unconstrained inflated cuff surface in free space.

[0078] FIGS. 16C and 16D schematically illustrate the hinging behavior of an optional serrated inflatable cuff of the present invention as the graft assumes different diameters.

[0079] FIG. 16E schematically illustrates differing radii of curvature between outer and inner hinge portions of an optional serrated inflatable cuff or channel of the present invention.

DETAILED DESCRIPTION OF THE INVENTION

[0080] FIG. 1 shows an endovascular graft 10 in its deployed configuration. Unless otherwise stated, the term “graft” or “endovascular graft” is used herein to refer to a prosthesis capable of repairing and/or replacing diseased vessels or portions thereof, including generally tubular and bifurcated devices and any components attached or integral thereto. For purposes of illustration, the graft embodiments described below are assumed to be most useful in the endovascular treatment of abdominal aortic aneurysms (AAA). For the purposes of this application, with reference to endovascular graft devices, the term “proximal” describes the end of the graft that will be oriented towards the oncoming flow of bodily fluid, typically blood, when the device is deployed within a body passageway. The term “distal” therefore describes the graft end opposite the proximal end. Finally, while the drawings in the various figures are accurate representations of the various embodiments of the present invention, the proportions of the various components thereof are not necessarily shown to exact scale within and among or between any given figure(s).

[0081] Graft 10 has a proximal end 11 and a distal end 12 and includes a generally tubular structure or graft body section 13 comprised of one or more layers of fusible material, such as expanded polytetrafluoroethylene (ePTFE). A proximal inflatable cuff 16 is disposed at or near a proximal end 14 of graft body section 13 and an optional distal inflatable cuff 17 is disposed at or near a graft body section distal end 15. Graft body section 13 forms a longitudinal lumen 22 configured to confine a flow of fluid therethrough and may range in length from about 5 cm to about 30 cm; specifically from about 10 cm to about 20 cm.

[0082] As shown in FIG. 1 and schematically in idealized form FIG. 16A, and as will be described in greater detail below, inflation of cuffs 16, 17 in free space (i.e. when graft 10 is not disposed in a vessel or other body lumen) will cause them to assume a generally annular or torodial shape (especially when graft body section 13 is in an unconstrained state) with a generally semicircular longitudinal cross-section. Inflatable cuffs

16, 17 will generally, however, conform to the shape of the vessel within which it is deployed. When fully inflated, cuffs 16, 17 may have an outside diameter ranging from about 10 mm to about 45 mm; specifically from about 16 mm to about 32 mm.

[0083] At least one inflatable channel 18 may be disposed between and in fluid communication with proximal inflatable cuff 16 and distal inflatable cuff 17. Inflatable channel 18 provides structural support to graft body section 13 when inflated to contain an inflation medium. Inflatable channel 18 further prevents kinking and twisting of the tubular structure or graft body section when it is deployed within angled or tortuous anatomies as well as during remodeling of body passageways (such as the aorta and iliac arteries) within which graft 10 is deployed. Together with proximal and distal cuffs 16 and 17, inflatable channel 18 forms a network of inflatable cuffs and channels in fluid communication with one other.

[0084] We have found the helical configuration of channel 18 in the FIG. 1 embodiment to be particularly effective in providing the needed kink resistance for effectively treating diseased body passageways such as AAAs, in which highly angled and tortuous anatomies are frequently found. In alternative embodiments, however, other cuff and channel configurations are possible. Inflatable channel 18 may be disposed helically as shown in FIG. 1, it may take on a more circumferential or annular rib and spine configuration as shown in the FIG. 2 embodiment, or otherwise. In another embodiment shown in FIG. 2A, one or more portions of inflatable channel 18 (or channel 58) or cuff 16 may optionally take on a zig-zag or serrated configuration as described below in conjunction with FIGS. 16C-16E. Such a configuration may be used to provide a similar desirable kink resistance or resistance to in-folding.

[0085] As also shown in FIG. 2A, in some configurations, a staggered longitudinal channel or spine 20 may be used alone or in conjunction with a serrated inflatable channel 18, 58 to promote the flexibility of graft body section 13 (or other graft portions in which inflatable channel 18 and spine 20 is disposed). Of course, spine 20 may also be continuous as shown in, e.g., the FIG. 1 embodiment in conjunction with the serrated channel 18, 58 of FIG. 2A.

[0086] The longitudinal and radial dimensions of inflatable channel 18 may vary as necessary both between different graft body sections and even within a single graft body section, depending on the indication for which graft 10 is intended to treat. Further, inflatable channel 18 may be oriented at various angles with respect to the longitudinal axis

25 of graft body section 13, and the pitch (the distance between helical or parallel windings of channel 18) may vary as necessary.

[0087] In the embodiment of FIG. 1, the channel pitch, or distance between each helical inflatable channel 18 winding, may range from about 2 mm to about 20 mm, depending on the overall size of graft body section 13 and the desired degree of kink resistance. We have found that a pitch of between about 4 mm and about 10 mm is effective for tubular embodiments of the present invention and a pitch of between about 3 mm and about 10 mm to be useful in bifurcated graft embodiments. The helix angle of each channel winding (measured with respect to a plane perpendicular to the graft body section longitudinal axis 25) may range from about 10 degrees to about 45 degrees; more specifically, from about 20 degrees to about 35 degrees in tubular and bifurcated graft embodiments. Finally, the width of inflatable channel 18 typically ranges from about 1 mm to about 8 mm; more specifically, from about 2 mm to about 4 mm.

[0088] Graft body section or tubular structure 13 and its associated components may be made from a variety of suitable materials, including ultra high molecular weight polyethylene, polyesters, and the like. As previously discussed, we have found constructing graft body section 13 primarily from one or more layers of ePTFE to be particularly useful. Details of how graft 10 may be fabricated (as well as all of the other grafts discussed herein) are more fully described in copending U.S. Patent Application Serial Nos. 10/029,557, 10,029,570, and 10/029,584, each filed on December 20, 2001 by Chobotov et al. In addition, U.S. Patent Application Serial No. 09/133,978 to Chobotov, filed February 9, 1998 and entitled "Endovascular Graft" and copending U.S. Patent Application Serial No. 09/917,371 to Chobotov et al., filed July 27, 2001 and entitled "Bifurcated Stent-Graft Delivery System and Method", the entirety of each of which are hereby incorporated herein by reference, teach a useful endovascular stent-graft and delivery system, respectively.

[0089] A proximal neck portion 23 is disposed in the vicinity of graft body section proximal end 14 and serves as an additional means to help seal the deployed graft against the inside of a body passageway. Proximal neck portion 23 has an inlet axis 27 that forms an inlet axis angle α in relation to graft body section longitudinal axis 25. This angled inlet axis 27 allows the graft to better conform to the morphology of a patient's vasculature in patients who have an angled vessel morphology, such as is often the case in the neck region of abdominal aortic aneurysms. The inlet axis angle α may range in any direction with respect to longitudinal axis 25 from about zero degrees to about 90 degrees, preferably from about 20 degrees to about 30 degrees. Proximal neck portion 23 may be tapered or flared to a

larger diameter in the proximal direction to facilitate this sealing function. Proximal neck portion 23 also serves as a means of providing a smooth fluid flow transition into graft lumen 22.

5 [0090] The network of inflatable cuffs 16, 17 and channel 18 may be inflated, most usefully *in vivo*, by introduction or injection of a material or medium through an injection port 33 that is in fluid communication with cuff 17 and the associated cuff/channel network. The material may comprise one or more of a solid, fluid (gas and/or liquid), gel or other medium. The material may contain a contrast medium that facilitates imaging the device while it is being deployed within a patient's body. For example, radiopaque materials containing elements such as bismuth, barium, gold, iodine, platinum, tantalum or the like may be used in particulate, liquid, powder or other suitable form as part of the inflation medium. Liquid iodinated contrast agents are a particularly suitable material to facilitate such imaging. Radiopaque markers may also be disposed on or integrally formed into or on any portion of graft 10 for the same purpose, and may be made from any combination of biocompatible radiopaque materials.

15 [0091] A connector member 24 is affixed to or integrally formed in graft body section 13, or as shown in FIG. 1, at or near graft body section proximal end 14 and proximal neck portion 23. In the embodiment of FIG. 1, connector member 24 is a serpentine ring structure comprising apices 28. Other embodiments of connector member 24 may take different configurations. Connector member 24 may be made from any suitable material that permits expansion from a constrained state, most usefully a shape memory alloy having superelastic properties such as nickel titanium (NiTi). Other suitable connector member 24 materials include stainless steel, nickel-cobalt alloys such as MP35N, tantalum and its alloys, polymeric materials, composites, and the like. Connector member 24 (as well as all stents and connector members described herein) may be configured to self-expand from a radially constrained state or be configured to expand as a result of an applied force (such as from an inflated balloon), or, in the case of some shape memory materials, a temperature change.

20 [0092] The configuration of connector member 24 shown in FIG. 1 comprises eight apices 28 (put more precisely, the FIG. 1 connector member 24 comprises eight proximal apices and eight distal apices; however, unless otherwise mentioned, the term "apices" refers in this context to either the proximal or distal set of apices in a single connector member, stent, or stent portion). Another particularly useful configuration is one shown in FIGS. 2, 3A, and 4-7 in which the connector member comprises twelve apices. Any number of apices up to twenty-four or more may be used in connector member 24. In

general terms, as the number of apices 28 on connector member 24 increase, connector member 24 will exhibit a greater conformability to the vessel wall when it is expanded from a radially constrained state.

5 [0093] No matter the number of apices present, one function of connector member 24 is to work in conjunction with proximal neck 23 in which it is typically embedded to help seal the deployed graft against the inside of a body passageway as previously described. It can also play a role in helping to keep graft 10 in place within the vessel wall and may also facilitate the opening of graft body section proximal end 14 during deployment.

10 [0094] Some apices 28 may also comprise a connector member connector element 30, described more fully below with respect to the embodiment of FIG. 2. In the FIG. 1 embodiment, in which connector member 24 comprises eight (proximal) apices 28, a connector element 30 is distributed on every other apex 28. We have found this configuration to be suitable for meeting the various performance requirements of the present invention. Other configurations are possible, including the twelve-apex connector member
15 24 shown in FIGS. 2, 3A, and 4-7 comprising six connector elements 30 distributed on every other apex 28. Other configurations in which, for example, connector elements are distributed on every apex, every third or fourth apex, or any other pattern are within the scope of the present invention.

20 [0095] Graft 10 further comprises a proximal stent 40 having a proximal end 42 and a distal end 44. Although other configurations are possible, proximal stent 40 in the FIG. 1 embodiment comprises a serpentine ring having four apices 46, or half the number of apices 28 of connector member 24. Note that proximal stent 40 in FIG. 1 takes on an optional tulip-shaped tapered profile in which the stent's diameter varies along its length. Such a profile serves to present sufficient radial force upon radial expansion of stent 40 to
25 reliably anchor graft 10 to the vessel or lumen wall within which it is deployed while, at its tapered distal end near graft body section 13, refraining from interfering with the sealing function performed by proximal cuff 16, proximal neck portion 23, and connector member 24. This profile also accommodates any taper that may be present in the host vessel or lumen.

30 [0096] As shown in FIG. 1, proximal stent 40 is disposed generally proximal to graft body section 13 and connector member 24. Proximal stent 40 is typically, though not necessarily, made a part of graft 10 by being affixed or connected to connector member 24 via connector elements as described in detail below. Proximal stent 40 may also be affixed or embedded directly to or in proximal neck portion 23 and/or other portions of graft body

section 13. In addition, the present invention includes embodiments wherein the connector member and proximal stent are not mechanically or otherwise fastened to one another but rather unified, formed of a monolithic piece of material, such as NiTi.

[0097] This configuration of proximal stent 40, connector member 24, proximal neck portion 23, and proximal cuff 16 helps to separate the sealing function of proximal cuff 16, which requires conformation and apposition to the vessel wall within which graft 10 is deployed without excessive radial force, from the anchoring function of proximal stent 40 (connector member 24 and proximal neck portion 23 play intermediate roles). This allows the sealing and anchoring functions each to be optimized without compromising the other. In addition, in part because proximal stent 40, connector member 24, and inflatable cuff 16 are longitudinally distributed along the graft body section longitudinal axis 25, a smaller, more flexible delivery profile ranging from about 10 French to about 16 French is possible; preferably below 12 French.

[0098] Proximal stent 40 may be manufactured from any of the materials suitable for connector member 24. When manufactured from a shape memory alloy having superelastic properties such as NiTi, proximal stent 40 may be configured to self-expand upon release from a constrained state.

[0099] Proximal stent 40 further comprises proximal stent connector elements 48 that are affixed to connector member connector elements 30 via coupling members as described more fully below in relation to FIGS. 2-6. Note that in the FIG. 1 embodiment, there is one proximal stent connector element 48 for every connector member connector element 30.

[0100] Proximal stent 40 also comprises struts 41 and may also comprise one or more barbs 43. A barb can be any outwardly directed protuberance, typically terminating in a sharp point that is capable of at least partially penetrating a body passageway in which graft 10 is deployed (typically the intimal and medial layers of a blood vessel such as the abdominal aorta).

[0101] When proximal stent 40 is deployed in the abdominal aorta, for example, typically in a location proximal to the aneurysm and any diseased tissue, barbs 43 are designed to work in conjunction with the distally-oriented blood flow field in this location to penetrate tissue and prevent axial migration of graft 10. This is why barbs 43 in the FIG. 1 embodiment are oriented distally with respect to graft body section 13.

[0102] In alternative embodiments, depending upon the material used in the manufacture of proximal stent 40, the clinical demands and other factors, the degree to which

barbs 43 help maintain the position of graft 10 within the vessel may vary. Consequently, the number, dimensions, configuration and orientation of barbs 43 may vary significantly, yet be within the scope of the present invention.

[0103] The length of barbs 43 in any of the embodiments of the present invention may range from about 1 mm to about 5 mm; more particularly, from about 2 mm to about 4 mm.

[0104] As shown in their free expanded configuration in FIG. 1 and as shown in greater detail in FIG. 1A, barbs 43 may be oriented in a distal direction and form an elevation angle β ranging from about 10 degrees to about 45 degrees or higher with respect to a longitudinal axis 29 of strut 41, projecting generally radially outward from graft lumen 22 away from proximal neck inlet axis 27. Disposing barbs at angle β provides the necessary embedding force to anchor graft 10 into the vessel or lumen in which it is deployed. Although not shown in the figures, the barb elevation may also be described when the graft 10 is deployed *in vivo* in a body lumen or vessel by a second angle β' measured relative to proximal neck inlet axis 27. This second barb elevation angle β' will typically range from about 5 degrees to about 45 degrees. For both barb elevation angles β and β' , similar orientations may be found with barbs in other embodiments of the present invention.

[0105] It is generally desirable that barbs 43 be oriented in a position generally parallel to the axis of the lumen in which they are deployed so that they are in a position to best resist the drag loads imposed by the flow field *in vivo* in certain applications. To this end, we have found it useful for one or more of barbs 43 to form an optional second barb azimuth or "kick" angle γ with respect to strut longitudinal axis 29 as shown in FIG. 1B. In this view, barb 43 is laterally biased in a plane that is tangent to an outside surface 37 of strut 41 and generally orthogonal to a plane in which angle γ is formed. The term "strut outside surface generally refers to that portion of the surface of strut 41 located opposite the proximal neck inlet axis 27, or that portion of strut 41 that when deployed will be in direct contact with the vessel or lumen wall. We have also found that providing lateral kick angle γ to barbs 43 contributes to greater barb stability when the barb is tucked behind an adjacent strut or tuck pad in a reduced diameter delivery configuration. In proximal stent 40, γ may range from between about 5 degrees and about 70 degrees relative to strut axis 41. Similar orientations may be found with barbs in other embodiments of the present invention.

[0106] The number of barbs, the length of each barb, each of the barb angles described above, and the barb orientation may vary from barb to barb within a single stent or between multiple stents within a single graft.

[0107] Note that although the various barbs (and tuck pads 45 discussed below) discussed herein may be attached to or fixed on the stent struts 41, we have found it useful that, as shown in the various figures, they be integrally formed as part of the stent struts. In other words, they can be mere extensions of the struts in which no joint or other connection exists. Because there is no joint, we have found the strength of the barb/strut interface to be very high, as is the fatigue resistance of the barbs. With no mechanical connection to join the barbs to the struts, reliability of the barb/strut interface is higher. In addition, the lack of a heat-affected zone in which the mechanical properties of a welded or brazed joint may be deleteriously affected is another significant advantage to having the barbs and tuck pads be integral to the stent.

[0108] Struts 41 may also comprise optional integral tuck pads 45 disposed opposite each barb 43. As is the case with the barbs, the number, dimensions, configuration and orientation of barb tuck pads 45 may vary significantly.

[0109] During preparation of graft 10 (and therefore proximal stent 40) into its reduced diameter delivery configuration, each barb 43 is placed behind a corresponding strut 41 (and optional tuck pad 45, if present) so to thereby prevent that barb from contacting the inside of a delivery sheath or catheter during delivery of the device and from undesired contact with the inside of a vessel wall. As described in copending U.S. Patent Application Serial No. 09/917,371 to Chobotov et al., the complete disclosure of which is incorporated herein by reference, a release belt disposed in one or more grooves 35 disposed on struts 41 retain proximal stent 40 in this delivery configuration.

[0110] Upon deployment of graft 10, and more particularly, proximal stent 40, (typically accomplished in part by release of this and other belts), the radial expansion of stent 40 results in a displacement of struts 41 so that the distance between them increases. Eventually this displacement becomes large enough so to free the barbs from behind the adjacent strut (and optional tuck pad 45, if present) and engage the wall of the lumen being treated. During experiments in which stents of the present invention having barbs described herein are released from a constrained delivery configuration to assume an expanded or deployed configuration, high speed video confirms that the barbs tend to release with a time constant that is generally an order of magnitude lower than the time constant associated with the radial expansion of the stent. In other words, during the stent deployment process, their barbs complete their deployment before the stent is fully expanded, so that the barbs may engage the vessel or lumen wall with maximum effectiveness.

[0111] Alternatively, and especially in the case when a different material such as stainless steel is used for proximal stent 40, an optional balloon may be used to expand stent 40 to free barbs 43 from their tuck pads 45 and to cause barbs 43 to engage tissue as desired. Even if a superelastic self-expanding proximal stent 40 is used in graft 10, such a
5 balloon may be used to help further implant barbs 43 into their desired position to ensure proper placement of graft 10.

[0112] Turning now to FIG. 2, another endovascular graft having features of the present invention is illustrated. Graft 50 has a proximal end 51 and a distal end 52 and comprises a tubular structure or graft body section 53 with a proximal end 54 and distal end
10 55. As with the FIG. 1 embodiment, graft body section 53 forms a longitudinal lumen 73 configured to confine a flow of fluid therethrough and may range in length from about 5 to about 30 cm; specifically from about 10 cm to about 20 cm. Proximal inflatable cuff 56 and optional distal inflatable cuff 57 form a seal when inflated to help prevent transmission of pressure (hemodynamic pressure when the fluid is blood) to the lumen or vessel walls in the
15 region between the proximal and distal cuffs. In addition, the cuffs help to prevent flow of fluid such as blood around the outer surface of graft body section 53.

[0113] Inflatable channel 58 comprises an inflatable longitudinal channel or spine 20 in fluid communication with a series of approximately parallel inflatable circumferential channels or ribs. We have found this configuration to be particularly useful
20 in providing effective kink resistance while allowing for rapid and relatively easy inflation of the cuffs and channels when using more viscous inflation materials. As shown in FIG. 2B, in alternative embodiments, longitudinal channel or spine 20 may take on a wave configuration. Under certain clinical conditions, this configuration may provide additional kink resistance by allowing longitudinal channel or spine 20 to foreshorten laterally and reducing the
25 potential it will kink directly into graft lumen. In addition, this configuration enables the physician or operator implanting graft 50 into the vessel or body lumen to make fine adjustments to the graft length *in situ* as necessary during implantation to ensure optimal graft placement without undesirable kinking.

[0114] Channel 58 is in fluid communication with proximal and distal cuffs
30 56 and 57, forming a network of inflatable cuffs and channels in fluid communication with each other. Fill port 59 is in fluid communication with distal cuff 57, inflatable channel 58, and proximal cuff 56, adding to this network for the introduction of an inflation medium into graft body section 53. Features of the FIG. 1 embodiment not discussed herein may be present in the FIG. 2 device.

[0115] Graft 50 of FIG. 2 also comprises a twelve-crown or twelve-apex proximal connector member 60, a two-stage six- and three-crown proximal stent 70, distal neck portion 77, distal connector member 124, and distal stent 128. Distal connector member 124 and distal stent 128 are analogous to connector member 60 and proximal stent 70 except that the distal stent in the FIG. 2 embodiment is single-stage and its optional barbs face in the opposite, or proximal direction relative to the barbs 74 of proximal stent 70. Distal connector member 124 is affixed or attached to distal stent 128, both of which are more fully described in relation to a bifurcated version of the present invention shown in FIGS. 8 and 9, respectively. Distal connector member 124 and distal stent 128 may be manufactured from materials and according to methods that are suitable for connector member 60 and proximal stent 70. Further, distal connector member 124 may be attached to, affixed to, formed integrally with tubular structure or graft body section 53, or more typically, distal neck portion 77. Distal connector member 124 further comprises fill port bridge 132.

[0116] FIG. 3A shows a detailed flat pattern view of the proximal connector member 60 shown in FIG. 2. Proximal connector member 60 comprises a distal end 66 and a proximal end 64 having twelve crowns or apices 65. Alternate proximal apices 65 comprise proximal connector member connector elements 62. These connector elements 62 each in turn comprises a proximal end 61, a distal end 63, and optional ears 80 disposed near distal end 63. Ears 80 provide for increased surface area on connector elements 62 to aid in maximizing the strength of the bond between connector element and graft proximal neck portion and further comprises one or more optional apertures 82 to further enhance such a bond as previously discussed. Opposing shoulder portions 84 may have rounded corners so to minimize their potential to snag, tear, or otherwise interfere with other components of the graft or the lumen in which it is deployed. Shoulder portions 84 also have one or more optional shoulder holes 85. These shoulder holes 85 are useful in helping to stabilize the proximal stent 70 and proximal connector member 60 device as they are coupled during assembly as discussed below in conjunction with FIG. 5A.

[0117] For grafts that treat AAAs, a significant anatomic dimensional parameter is the minimum treatable neck length. Generally, in the abdominal aorta proximal to the aneurysm or diseased area to be treated, this parameter anatomically may be described as the distance between the distalmost renal artery ostium distal edge (e.g., that portion of the ostium closest to the aneurysmal tissue) and the location in the aorta where the graft is intended to create a proximal seal. Likewise, in the iliac artery region distal to the aneurysm or diseased area to be treated, this parameter may be described as the distance between the

ostium proximal edge of either of the internal iliac arteries (i.e., the ipsilateral or the contralateral hypogastric artery) and that vessel location where the graft is intended to create a distal seal. Grafts that are designed treat shorter minimum treatable neck lengths generally may be used to treat a larger patient population than grafts that are not so designed, resulting in a clinically and commercially more advantageous device.

[0118] When describing this neck length in terms of the bifurcated graft of FIG. 7 as an example, the corresponding dimensions have two primary components. One component is the distance between the free edge of the graft neck portion (for instance, proximal neck portion edge 109) and the opposite end of the connecting member (e.g., distal end 66 of proximal connecting member 60 shown in FIG. 3A or proximal end 127 of distal connecting member 124 shown in FIG. 8). This distance is illustrated as length L1 in the alternative connector member embodiment of FIG. 3B. The longitudinal dimension of the connecting members governs this first component.

[0119] The second component is the distance between the opposite end of the connecting member (as described above) and that portion of the inflatable cuff (e.g., proximal inflatable cuff 111 or optional distal inflatable cuffs 117) that seals against the vessel wall. This distance is illustrated in proximal neck portion 23 of FIG. 3B as length L2. The longitudinal dimension of the graft in the region of the proximal or distal neck portions govern this second component.

[0120] When a graft of the present invention is loaded into a delivery sheath or catheter, its corresponding connecting members move from a first expanded configuration to a second collapsed configuration. The length of the connecting members of FIGS. 1, 2-3A and 5-8 typically are minimized to the point that the strains experienced in their crowns or apices do not exceed the prescribed analytical threshold.

[0121] FIG. 3B-3C show an alternative connector member design that is advantageous in that it is not limited by such strain thresholds considerations as described above. Connector member 89 comprises not a continuous ring but one or more discrete connector member elements in the form of discrete anchors 91, schematically shown in the flat projection of FIG. 3B as embedded in graft proximal neck portion 23. A more detailed example of a similar single anchor 91 is shown in FIG. 3C. This embodiment of connector member 89 comprising one or more anchors 91 may be used in any of the graft embodiments discussed herein, alone or in combination with one or more of the continuous ring embodiments disclosed herein.

[0122] Anchors 91 may be shaped as shown to maximize their resistance to being pulled out from the graft neck portion 23 under high traction loads. Each may comprise a distal portion 95, an intermediate portion 96, and a connector element 97. In the illustrated anchor embodiments of FIGS. 3B and 3C, connector member element 91 takes on a "T" shape in which proximal end 96, when integrated with neck portion 23, extends beyond the edge 109 of graft neck portion 23. Distal section 95 is enlarged so as to enhance pull-out resistance. Anchors 91 may be comprised of any of the materials discussed herein suitable for connector members and/or stents, such as NiTi, stainless steel, alloys thereof, and the like.

[0123] FIG. 3C shows additional details of features discussed herein in conjunction with other embodiments of the connector member. For instance, connector element 97 may comprise optional ears 101 and optional apertures 103 to maximize the strength of the bond between connector element 89 and the graft neck portion. Opposing shoulder portions 105 may also have one or more optional shoulder holes 107. Advantages to these features are more fully described elsewhere herein and in co-pending U.S. Patent Application Serial No. 10/10/029,584, which teaches methods for attaching anchors 91 to the endovascular graft neck portion.

[0124] Because the anchors 91 do not have crowns, design and performance concerns relating to strains generated in ring-type connector member embodiments are not relevant. Therefore, the length L1 of the portion of each anchor 91 that is embedded in neck portion 23 is governed to a large extent by the amount of material that is needed to achieve a sufficient degree of anchor 91 fixation into graft neck portion 23. Features such as ears 101 over which the graft material may be folded during assembly, and holes through which the fluorinated ethylene-propylene copolymer (FEP) aqueous dispersion (which serves as a type of adhesive to fix the anchors 91 within the graft layers) may wick, allow adequate fixation to be achieved in a minimum distance. As long as adequate fixation is achieved, the length from the edge of the graft flap to the embedded end of the anchor can be made arbitrarily short to help minimize that component of the graft neck length, which in turn enables the aforementioned clinical and commercial advantages.

[0125] Each anchor may have a longitudinal length L1 ranging between approximately 0.5 mm and approximately 7 mm or higher. This generally enables treating a larger range of patients than with connector member 60, for example. The number of anchors 91 used will vary with the graft, the amount of anchoring strength desired, and the like. In one configuration, the graft may comprise between approximately four anchors and approximately ten anchors, while other graft embodiments may have a greater or lesser

number of anchors 91. In a bifurcated graft embodiment such as that discussed in conjunction with FIG. 7, we have found it useful to incorporate a connector member 89 in one or both of the first and second bifurcated portion distal ends as alternatives to the distal connector members 124 and 150. Incorporation of connector member 89 into at least one of bifurcated portions 114, 115 may allow the graft in the vicinity of the connector member 89 and distal neck portion 154 of portions 114, 115 to be compressed to a smaller diameter, thus affording the possibility of using a lower profile delivery sheath or catheter. A bifurcated graft configuration in which five distal anchors 91 may be used in conjunction with a distal stent having five connector elements in one of or both graft legs is particularly advantageous. As can be appreciated, anchors 91 can be used on either end of the endovascular grafts illustrated in FIGS. 1, 2, and 7, in any combination with or without ring-type connector members.

[0126] Another advantage of this particular design for connector member 89 arises from the fact that, in general, connector member 89 will comprise less material than an equivalent ring design, such as proximal connector member 60 (FIGS. 3, 5) or distal connector member 124 (FIG. 8). This in turn allows the compressed diameter of the graft in the vicinity of the connector member 89 and proximal neck portion to be relatively small, affording the possibility of using a lower profile delivery sheath or catheter. This advantage may be especially useful in the FIG. 7 distal neck portion 154 of the shorter second leg portion 115 of bifurcated graft 100, where upon loading in the delivery catheter or sheath, due to the fact that the distal stent 128 and distal connecting member 150 associated with the second bifurcated portion 115 lie against the graft material in the first bifurcated portion 114. In certain sheath or catheter graft loading configurations, this region is profile-limiting and in fact can dictate the diameter of the delivery catheter or sheath used for the graft. A smaller profile capability ultimately results in the ability to access smaller body lumens, translating into the advantage of being able to treat a wider range of patients than would otherwise be possible.

[0127] In the embodiment illustrated in Figure 3D, the connector member may comprise one or more one or more discrete V-shaped connector member elements 98, alone or in combination with anchors 91. In the illustrated embodiment, the V-shaped connector member element 98 can have a connector element 97 disposed on each side 99 of the V-shaped connector member elements. The number of connector elements 97 attached to the graft depends on the attachment scheme and graft diameter, but there typically will be between 8 and 10 connector elements 97 (e.g., 4 or 5 V-shaped connector member elements).

In other configurations, connector elements 97 may be distributed on every other side 99 of the V-shaped connector member elements, if desired.

[0128] The connector members may be used with a variety of types of stents. For example, in some embodiments the connector members may be used with a single-stage or two-stage stent. As illustrated in FIGS. 4-5 and 6-7, a two-stage proximal stent 70 has a proximal end 76 and a distal end 79 with proximal stent connector elements 72. Proximal stent connector elements 72 have opposing shoulder portions 78 that may mirror opposing shoulder portions 84 of distal stent connector elements 62.

[0129] Proximal stent 70 comprises struts 71, any one of which may further comprise one or more barbs 74. Optional barb tuck pads 86 near each barb serve to shield barbs 74 when graft 50 is in its reduced diameter delivery configuration. Struts 71 or tuck pads 86 may also contain an optional barb tuck slot 83 to help retain barbs 74 while graft 50 (and consequently proximal stent 70) is in its delivery configuration. Upon deployment of graft 50 as previously described with respect to the FIG. 1 embodiment, barbs 74 are released from barb tuck slots 83 and are placed in their operational, or deployed configuration, as shown in FIGS. 2 and 6. When so deployed in a patient vessel, proximal stent 70 is expanded, forcing barbs 74 at least partially into the vessel wall to emplace graft 50 therein and to resist fluid flow forces that might otherwise dislodge graft 50.

[0130] Proximal stent 70 also may comprise one or more sets of optional grooves 87 for housing device release bands as previously discussed.

[0131] Unlike proximal stent 40 of FIG. 1, however, proximal stent 70 is a two-stage component having a first, or six-crown region 90 and a second, or three-crown region 92. The first, or six-crown region 90 comprises a serpentine ring having six apices 94 (i.e., six distal and six proximal apices). Likewise, the second, or three-crown region 92 comprises a serpentine ring having three apices 93, the distal apices of which connect to every other proximal apex 94 of six-crown region 90. Note that proximal stent 70 is typically made from a single piece of material such that there are no joints or connections between each stage (such as a mechanical connection or a weld, etc.). However, other configurations in which two or more stages may be so joined or connected from separate parts or stents to form a single stent are possible; likewise, single-piece stents having more than two stages are also possible.

[0132] Proximal stent 70 may exhibit a greater outward radial force at three-crown region 92 than in six-crown region 90. Such a design is particularly useful in a clinical setting in which it is desired that such outward radial force be applied within a healthier

section of vessel, more remote from the site of disease. Proximal stent 70 may accordingly perform the anchoring function within a portion of vessel that can accommodate such radial force.

[0133] FIG. 5 is a flat pattern view of connector member 60 joined to proximal stent 70. For this embodiment, there is a relationship among the various apices 65, 93 and 94 of the connector member 60 and the two stages of proximal stent 70, respectively, in which there are twelve connector member apices 65, six apices 94 in the proximal stent first or six-crown region 90 and three apices 93 in the proximal stent second or three-crown region 92.

[0134] While the actual number of apices may vary as previously discussed, this more generally illustrates a useful convention for the present invention in which the relationship among the various apices may be described: for instance, if the number of connector member 60 apices 65 is denoted "n", "n/2" then denotes the number of proximal stent 70 first or six-crown region 90 apices 94 and "n/4" as the number of proximal stent 70 second or three-crown region 92 apices 93. Other useful embodiments include those in which there are "n" connector member apices, "n" proximal stent first region apices, and "n/2" proximal stent second region apices. These ratios may vary as appropriate; these particular sets of ratios are merely illustrative.

[0135] Note also in FIG. 5 that connector member connector elements 62 are coupled to proximal stent connector elements 72 via coupling members 54.

[0136] FIG. 5A is a side view of proximal stent connector element 72, connector member connector element 62, and coupling member 32. Coupling member 32 is a wire or similar element wrapped to form a coil around the overlapping connector member connector element 62 and proximal stent connector element 72 to mechanically join connector member 60 to proximal stent 70. Alternatively, any other suitable joining technique, such as welding, brazing, soldering, mechanical means, adhesive, etc. may be used to join these components of the graft 50. We have found, however, that mechanical means such as coupling member 32 is most useful in that it avoids problems presented by techniques such as welding, etc., where possible heat-affected zones some distance from the joint may deleteriously affect the microstructure of the stent/connector element material, especially when that material is nickel titanium, thus having a negative impact on the joint strength, fatigue life, and ultimately the integrity of graft 50.

[0137] Any suitable member may be used for coupling member 32 although we have found a wire or wire-like member having a circular cross-sectional shape to be

useful (although any shape may be used). Optimally, the wire coupling member 32 may be formed of a suitable metal such as nickel, stainless steel, nickel-titanium, etc. The wire may have a diameter ranging from about 0.002 to about 0.006 inch; more specifically from about 0.003 to about 0.005 inch.

5 **[0138]** To secure the connector elements 62 and 72 to one another, coupling member 32 may be wound around the matched connector elements one or more times. We have found that providing enough windings to present a single layer of wire in which the windings are immediately adjacent one another from shoulder 78, 84 to shoulder 78, 84 provides sufficient strength and stiffness to the joint thus created without detracting from the
10 low delivery profile afforded by the novel design of graft 50. Thus the number of optimal windings from graft to graft will vary but typically ranges from about 6 to about 18 windings in most applications. With coupling members 32 in place, connector member connector elements 62 and proximal stent connector elements 72 are securely coupled to one another. The features and advantages of coupling member 32 discussed herein may be utilized by any
15 of the embodiments of the present invention herein discussed.

[0139] FIG. 6 is a perspective view of connector member 60 joined to proximal stent 70 in this way in their expanded, or deployed configuration. Graft body section 53 and other graft components are removed for clarity of illustration. Barbs 74 are shown in their deployed state, released from optional barb tuck pads 86. In the illustrated
20 embodiment, a twelve-apex connector member 60 is connected to a first six-apex or six-crown region of a proximal or distal stent 90 and that stent has a second three-apex or three-crown region 92 integral with or joined to the six-crown region. While not illustrated, another useful embodiment is one in which an eight-apex connector member (or a connector member having eight connector member elements) is connected to a first eight-apex or eight-
25 crown region of a proximal stent and that stent has a second four-apex or four-crown region integral with or joined to the eight-crown region.

[0140] FIG. 7 illustrates another embodiment of the invention in the form of a bifurcated endovascular graft 100. A bifurcated device such as endovascular graft 100 may be utilized to repair a diseased lumen at or near a bifurcation within the vessel, such as, for
30 example, in the case of an abdominal aortic aneurysm in which the aneurysm to be treated may extend into the anatomical bifurcation or even into one or both of the iliac arteries distal to the bifurcation. In the following discussion, the various features of the graft embodiments previously discussed may be used as necessary in the bifurcated graft 100 embodiment unless specifically mentioned otherwise.

[0141] Graft 100 comprises a first bifurcated portion 114, a second bifurcated portion 115 and main body portion 116. The size and angular orientation of the bifurcated portions 114 and 115, respectively, may vary – even between portion 114 and 115 – to accommodate graft delivery system requirements and various clinical demands. For instance, each bifurcated portion or leg is shown in FIG. 7 to have a different length, but this is not necessary. First and second bifurcated portions 114 and 115 are generally configured to have an outer inflated diameter that is compatible with the inner diameter of a patient's iliac arteries. First and second bifurcated portions 114 and 115 may also be formed in a curved shape to better accommodate curved and even tortuous anatomies in some applications.

[0142] Together, main body portion 116 and first and second bifurcated portions 114, 115 form a continuous bifurcated lumen, similar to lumens 22 and 73, which is configured to confine a flow of fluid therethrough. And although not shown in FIG. 7, graft 100 does not have to have a second bifurcated portion 115, in which case the bifurcated lumen is formed between main body portion 116 and first bifurcated portion 114.

[0143] First and second bifurcated portions 114 and 115 each comprises a network of inflatable cuffs and channels as discussed with respect to the FIG. 2 embodiment, including inflatable channel 113. Channel 113 comprises one or more optional inflatable longitudinal channels 110 (e.g., a spine) in fluid communication with one or more approximately parallel inflatable circumferential channels 144, all of which are in fluid communication with optional distal inflatable cuffs 117 and 119. Channels 110 may take on a linear or curvilinear (e.g., wave-shaped) configuration.

[0144] As with the embodiments previously discussed, the number of inflatable circumferential channels 144 may vary with the specific configuration of the graft as adapted to a given indication. Generally, however, the number of inflatable circumferential channels 144 per bifurcated portion may range from 1 to about 30, preferably about 10 to about 20. Similarly, the dimensions, spacing, angular orientation, etc. of circumferential inflatable channels 144 may vary as well.

[0145] For instance, the distance between and width of each circumferential inflatable channel 144 may vary along the length of the graft or may be constant. The pitch or inter-ring distance may range from about 2 mm to about 20 mm; specifically, it may range from about 3 mm to about 10 mm. Circumferential inflatable channels 144 are each typically between about 2 mm and about 4 mm wide, but may be from about 1 mm to about 8 mm wide. Each longitudinal channel 110 is typically from about 2 mm to about 4 mm wide, but may vary, together or independently, to be from about 1 mm to about 8 mm wide.

[0146] In the embodiment of FIG. 7, channel 113 forms a continuous cuff and channel network extending from first bifurcated portion 114 to main body portion 116 to second bifurcated portion 115. Accordingly, inflatable channel 113 fluidly connects into a network with proximal inflatable cuff 111, secondary proximal cuff 112, circumferential inflatable channels 144, optional distal inflatable cuff 117 and optional distal inflatable cuff 119. Note that spine or longitudinal channels 110 extend proximally along main body portion 116 to be in fluid communication with cuffs 111 and 112.

[0147] In some embodiments, it is often desirable to provide the graft of the present invention, especially bifurcated embodiments such as that shown in FIG. 7, with the capacity to compensate for the length or tortuosity of the vessel or body lumen into which the graft may be placed without unacceptable kinking. This is especially desirable for the treatment of AAAs in which tortuous anatomies may otherwise preclude the possibility of endovascular therapy.

[0148] We believe that the ability of grafts such as that described for instance in conjunction with FIG. 7 to foreshorten is governed by limitations imposed by the graft inflatable spine or longitudinal channel 110. Therefore, considered alternatives to the spine 110 design as seen in the graft of, e.g., FIG. 7 may improve the ability of the inventive graft limbs 114, 115 to lengthen or shorten without unacceptable levels of kinking (which results in clinically undesirable graft lumen intrusion, which could affect perfusion of remote vessels).

[0149] Longitudinal channel or spine 110 may be constructed with a weld or seam pattern that creates one or more predetermined kink points that would allow the channel 110 to predictably kink one or more times between inflatable channels 144, resulting in less intrusion of the graft material into the graft lumen for each kink as the legs and/or body portion of the graft

[0150] FIGS. 7A-7B illustrate, in schematic form, a graft of the present invention without predetermined kink points. In FIG. 7A, for instance, a schematic flat view of the graft channel pattern of the first bifurcated portion 114 of the FIG. 7 bifurcated graft 100 is shown. Longitudinal graft channel or spine 110 runs vertically down the length of first bifurcated portion 114 and is intersected by a symmetric series of inflatable channels or rings 113. Uninflatable sections 201 of graft 100 are shown in between channels 113. Taken in longitudinal cross section between two such channels 113 in FIG. 7B, first bifurcated portion 114 with graft lumen 22 is shown with a graft leg kink. During foreshortening, channel or spine 110 may kink at the approximate midpoint 125 between adjacent inflatable channels

113 in the uninflatable section of the graft wall. The amount of foreshortening in this FIG. 7B example is shown by the now-shortened distance between points A and C as compared to the distance between these same points before the kink occurred. This and other kinks will contribute to the total amount of longitudinal foreshortening experienced by spine 110. The amount of kinking corresponds to the intrusion of point B on either side of the graft first bifurcated portion 114 into lumen 22.

[0151] Configuring the pattern of longitudinal channel or spine 110 to have one or more predetermined kink points 123' along its length between channels 113 as shown in FIG. 7C will reduce the intrusion of any kinks that form into graft lumen 22. As illustrated in FIG. 7D, two respective kinks 123 are shown at each of the two designated points 123', doubling the number of kinks in the same length between the adjacent channels 113.

Although not shown in the Figures, kink points 123' may take on a wide variety of simple or complex shapes. For instance, kink point 123' may be a single line or it may take on triangular, rectangular, semicircular, or other shapes. Neither is it necessary for kink points 123' to be symmetrically disposed on opposite sides of spine 110 as shown in FIG. 7C; for example, a single kink point on one side of spine 110 between adjacent channels would suffice as long as it serves the intended function of initiating a kink as herein described.

[0152] Note that the amount of luminal intrusion of point B' at each kink shown in FIG. 7D is smaller than that for point B of FIG. 7B. If even less intrusion into lumen 22 is desired, a greater number of predetermined kink points may be created on longitudinal lumen 110 between inflatable channels 113. While the discussion of predetermined kink points is discussed mainly in regards to the bifurcated graft of FIG. 7, it should be appreciated that predetermined kink points may also be designed into the embodiments of FIGS. 1 and 2.

[0153] In alternative embodiments of the graft of FIG. 7 as well as that of FIGS. 1 and 2, numerous other inflatable channel and cuff configurations are possible. The inflatable channel for instance may be disposed longitudinally, horizontally, in a helical fashion, serrated, zigzag, or otherwise. One or more additional cuffs may be disposed on either or both bifurcated portions 114 and 115 as well as main body portion 116. In other embodiments, graft 100 may have compartmentalized channels and cuffs requiring multiple sites from which they are inflated and may use multiple inflation materials to optimize properties in each region.

[0154] Second bifurcated portion 115 may be of a similar construction to first bifurcated portion 114. In the FIG. 7 embodiment of graft 100, second bifurcated portion 115

is of a unitary, continuous construction with first bifurcated portion 114 and main body portion 116. Alternatively, first and second bifurcated portion 114 and 115 respectively may be singly or jointly formed separately from a main body portion and may be joined to the main body portion before deployment in the body passageway or *in vivo* after such
5 deployment.

[0155] First and second bifurcated portions 114 and 115 may be generally cylindrical in shape when deployed, and will generally conform to the shape of a vessel interior within which they are deployed. Their length as measured from main body portion 116 may range from about 1 cm to about 10 cm or more. The nominal inflated outside
10 diameter of the distal ends of the first and second bifurcated portions 114 and 115 at cuffs 117 and 119 may range from about 2 mm to about 30 mm, preferably from about 5 mm to about 20 mm.

[0156] Main body portion 116 comprises a proximal inflatable cuff 111 and an optional secondary proximal inflatable cuff 112 in fluid communication with one or more
15 inflatable longitudinal channels 110. As with other embodiments, proximal cuff 111 serves primarily to seal graft 100 firmly against a lumen wall. Secondary proximal inflatable cuff 112 has been found to confer additional kink resistance on graft 100, particularly in those clinical applications in which the vessel in which the graft is deployed is highly angled or tortuous. The nominal inflated outside diameter of secondary proximal inflatable cuff 112
20 may range from about 10 mm to about 45 mm, preferably from about 15 mm to about 30 mm, while the nominal inflated outside diameter of proximal cuff 111 may range from about 10 mm to about 45 mm, preferably from about 16 mm to about 32 mm. Main body portion 116 may range in length from about 2 cm to about 10 cm; preferably from about 4 cm to about 8
25 cm.

[0157] Endovascular graft 100 further comprises a proximal connector member 118, proximal stent 120, and proximal neck portion 146 all of which may be similar to those components discussed above in reference to FIGS. 2-6. Coupling members (not shown) may join proximal stent 120 and proximal connector member 118 as discussed with respect to the embodiments of FIGS. 1-6. Proximal connector members, proximal connector
30 member elements, and proximal stents as discussed in conjunction with the FIGS. 1 and 2 embodiments are also possible for use in bifurcated graft 100.

[0158] In bifurcated embodiments of grafts having features of the invention which also have a biased proximal end that forms an inlet axis angle, the direction of the bias or angulation can be important with regard to achieving a proper fit between the graft and the

morphology of the deployment site. Generally, the angular bias of the proximal end of the graft, proximal neck portion or proximal anchor can be in any direction. Preferably, the angular bias is in a direction and of a magnitude consistent with the mean angulation of the type of lesion (e.g. abdominal aortic aneurysm) intended for treatment with the graft.

5 **[0159]** As with proximal stent 70 of the embodiments shown in FIGS. 2 and 4-6, proximal stent 120 comprises barbs 121 which are oriented in a distal direction for reliable anchoring against the direction of pulsatile forces *in vivo* when the device is implanted in the abdominal aorta, for instance, to treat an abdominal aortic aneurysm.

10 **[0160]** One or both bifurcated portions 114 and/or 115 may further comprise a distal connector member 124 and/or 150, a distal stent 128, and a distal neck portion 154. The embodiment of FIG. 7 has distal connector member 124 and distal stent 128 disposed at the distal ends of each of first and second bifurcated portions 114 and 115, respectively. Distal connector member 124 and distal stent 128 are shown in greater detail in FIGS. 8 and 9.

15 **[0161]** As discussed with respect to the FIG. 2 embodiment and as shown more clearly in FIG. 8, distal connector member 124 disposed at or near first bifurcated portion 114 comprises distal connector member connector elements 130 and an optional fill-port bridge 132. Fill-port bridge 132 serves to prevent interference by distal connector member 124 with the manufacture of graft 100 and with the injection of an inflation medium, while preserving the continuous ring structure of distal connector member 124.

20 **[0162]** Inflatable channels 113 (and other inflatable members of the invention) are in communication with a fill port 160 through distal inflatable cuff 117. Fill port 160 may be disposed alternatively on second bifurcated portion 115 or graft main body portion 116, and more than one fill port may be used. Fill port 160 is configured to accept a pressurized source of fluid (gas and/or liquid), particles, gel or combination thereof as previously discussed.

25 **[0163]** As discussed with respect to the FIG. 2 embodiment, FIG. 9 details a flat pattern of distal stent 128, which includes distal stent connector elements 134. Distal connector member connector elements 150 are configured to be coupled with distal stent connector elements 134 via coupling members (not shown) similar to those discussed with respect to the FIGS. 1-6 embodiments. Distal stent 128 comprises one or more optional distal stent barbs 136, one or more optional distal stent barb tuck pads 138 and one or more optional sets of grooves 140 for housing device release bands, each of which functions in a similar fashion to the corresponding features of embodiments discussed above. Distal stent barbs

136 are oriented proximally, opposite the direction of orientation of barbs 121, to accommodate the environment often found in the iliac arteries that can cause the bifurcated portions 114 and 115 to migrate proximally *in vivo*. Distal barbs 136 may also be oriented distally (not shown) in distal stent 128 or in any of the distal stent embodiments disclosed
5 herein. Note that only two distal stent barbs 136 are shown in FIG. 9 for the purposes of clarity of illustration despite a larger number being depicted in the FIG. 7 embodiment of the present invention. It is understood that all embodiments of the present invention includes proximal and distal stents each of which may optionally comprise one, two, or any number of barbs and any combination of which may be oriented distally, proximally, or in any other
10 direction.

[0164] Similar to the embodiments of FIGS. 1 and 2, distal stent 128 may be coupled to one or both of bifurcated portion 114, 115. Stent 128 may be coupled to bifurcated portion 114, 115 with a distal connector member 124, 150 or one or more discrete connector member elements 89 (FIGS. 3B-3D). In one useful embodiment, any of the stents
15 and connector members (or connector member elements) described herein can be disposed on proximal neck portion 146 and one or both of bifurcated portions 114, 115 may have a five-apex connector member (or a connect member having five connector member elements) that is coupled to a distal stent 128 that has a five apex or five-crown region. As can be appreciated, any of the stents, connector members, and connector member elements described
20 herein with any combination of the number of connector member apices, connector member elements, and stent crowns can be used on one or both of bifurcated portions 114, 115, in any combination.

[0165] The optional distal connector member 150, disposed in the FIG. 7 embodiment at or near distal end 152 of second bifurcated portion 115, has a structure similar
25 to that of distal connector member 124 of first bifurcated portion 114, with the exception of the absence of fill-port bridge 132. Other embodiments of the invention include bifurcated grafts in which the distal connector member 150 includes a fill-port bridge.

[0166] FIGS. 10-16E illustrate additional optional features of the present invention that may be used in any of the various stents, channels, cuffs, and connector
30 members of the present invention, in any combination.

[0167] Turning to FIG. 10, a simplified detail of a proximal apex 93 of the second or three-crown region 92 of proximal stent 70 is shown. An outer surface 170 of apex 93 takes on a circular radius of curvature as defined by circle 172 having a radius r_1 . An inner surface 174 of the stent strut apex 93 takes on an elliptical shape as shown by ellipse

176. In the configuration of FIG. 10, circle 172 and ellipse 176 offset as shown by reference numeral 177; however, they may share a common center. Radius r_4 shown at one of the foci of ellipse 176; the foci are shown as separated by a distance 171 in FIG. 10.

[0168] We have found that for the NiTi stents used in the present invention, such a configuration provides for a more diffuse strain distribution in the stent and reduces the peak strains experienced during assembly and *in vivo*, while also allowing for a smaller delivery profile as compared to other configurations, particularly in the proximal apex 93 of the second or three-crown region 92 of proximal stent 70. However, the stent apex configuration of FIG. 10 may be used in any other stent or connector member apex described herein, and may be used for components comprising material other than NiTi.

[0169] In the example of FIG. 10 wherein proximal apex 93 of the second or three-crown region 92, we have found that for NiTi components radius r_1 of between about 0.030 inch and about 0.070 inch; specifically about 0.050 inch is useful, while an offset 171 of between about zero and about 0.050 inch; specifically about 0.0025 inch, is effective. A radius r_4 of between about 0.010 inch and about 0.030 inch; specifically about 0.020 inch, is useful as well.

[0170] FIG. 11 details an alternative offset circular apex configuration. Here, a simplified detail of proximal apex 94 in the first or six-crown region 90 of proximal stent 70 is shown (without a transition region to the second or three-crown stent region as seen in, e.g., FIG. 4 for clarity of illustration). An outer surface 180 of apex 94 takes on a circular radius of curvature as defined by circle 182 having a radius r_2 . An inner surface 184 of apex 94 takes on a circular radius of curvature defined by circle 186 having a radius r_3 . Radius r_2 may be equal to or greater than radius r_3 and be within the scope of the present invention. The centers of circles 182 and 186 are offset from each other as indicated by reference numeral 188 in FIG. 11. This offset 188 may be equal to, greater than, or less than the width of the strut 71 in the region of apex 94.

[0171] We have found that when NiTi is used for the stents and connector members of the present invention, such a configuration is effective in distributing the peak strains experienced in the stent from the apex 94 to stent strut 71 as compared to other configurations, particularly in the proximal apex 94 of the first or six-crown region 90 of proximal stent 70. However, the offset circular apex configuration of FIG. 11 may be used in any other stent or connector member apex described herein, and may be used for components comprising material other than NiTi.

[0172] When used in the proximal apex 94 of the proximal stent first or six-crown region 90, we have found offset values ranging from about zero to about 0.030 inch; particular about 0.020 inch, to be effective in NiTi stents having expanded, or deployed diameters ranging from about 16 mm to about 26 mm. We have also found effective a configuration in which radius r_2 ranges from about 0.020 inch to about 0.040 inch; more particularly about 0.035 inch, and in which radius r_3 ranges from about 0.005 inch to about 0.020 inch; in particular about 0.010 inch.

[0173] Optional taper or tapers may be incorporated into the struts 41 and 71 of the various stent embodiments of the present invention as well as the various proximal and distal connector members. In general, incorporating one or more tapers into the struts on both proximal and distal stents provide greater space in the tapered region to accommodate alternative features such as barbs and tuck pads. It allows for a smaller deployment profile when the component is in a radially collapsed delivery configuration. We have found that when configuring the various stents and connector elements of the present invention into this reduced diameter delivery profile, the stents experience a large degree of bending strain that is often poorly or locally distributed. Tapering certain stent struts in particular locations helps to distribute this strain more evenly throughout the stent or connector member and to manage the peak strains. The examples of FIGS. 12 and 13 are now introduced and discussed below.

[0174] In FIG. 12, a simplified section of the second or three-crown region 92 of proximal stent 70 is depicted in which the stent struts 71 taper from a maximum width 190 (which may or may not equal a width of strut 71 in region of apex 93) to a minimum width 192. The optional taper, expressed as the ratio of the maximum width 190 to the minimum width 192, may vary widely depending on the particular region of the stent or connector member, the material used, and other factors. Taper ratios ranging from 1 to about 10 or greater are within the scope of the present invention. It is also within the scope of the present invention for the stent struts 71 to exhibit no taper.

[0175] For example, in a proximal stent 70 three-crown region 92 made from NiTi, we have found effective a maximum strut width 190 ranging from about 0.016 inch to about 0.032 inch; particularly from about 0.022 inch and about 0.028 inch, and a minimum strut width 192 of between about 0.010 inch and about 0.026 inch; particularly from about 0.012 inch and about 0.022 inch. The optional tapered strut feature described herein and shown in FIG. 12 may be used in any other stent or connector member described herein, and may be used for components comprising material other than NiTi.

[0176] Turning now to FIG. 13, a simplified section of distal stent 128 is shown as an example of optional tapering that results in asymmetric crowns. In this example, distal stent 128 comprises a distal apex or crown 196 exhibiting a width 198 and a proximal apex or crown (with connector element 134 removed for clarity of illustration) 200 exhibiting a smaller width 202. It is within the scope of the present invention for width 198 and width 202 to be equal.

[0177] We have found that, especially for the distal stents of the present invention, an asymmetric crown in which the distal apex 200 has a smaller strut width than that of the proximal apex 196 results in a difference in the expansion force exerted between each of the proximal and distal apices. When deployed in a diseased lumen or vessel, the proximal apices of such a stent having this configuration will tend to exert a smaller expansion force near the graft seal zone, reducing the potential for such a stent to cause trauma to tissue in the seal zone near the cuffs (where weaker, more diseased tissue tends to reside). Such a configuration also facilitates a consistent, safe and predictable deployment when the component moves from a reduced diameter delivery profile to an expanded treatment profile. Finally, such a taper reduces the flare exhibited by the distal apex 200; this in turn provides for a smaller distal stent delivery profile when the distal stent is in a reduced-diameter configuration. Taper ratios (defined in the same manner above as the ratio between width 198 and width 202) ranging from 1 to about 10 or higher are within the scope of the present invention.

[0178] For distal stent 128 comprising NiTi, we have found that a width 202 ranging from about 0.010 inch to about 0.026 inch; specifically from about 0.012 inch and about 0.024 inch to be useful, and we have found a width 198 ranging from about 0.016 inch to about 0.032 inch; specifically from about 0.017 inch to about 0.028 inch to be useful.

[0179] Of course, the various types of offset radii and combinations of elliptical and circular apex radii may be used to effect these tapers and ratios so to further cause the desired behavior during assembly into a reduced-diameter delivery configuration, effective delivery and performance *in vivo*.

[0180] FIGS. 14 and 15 illustrate two additional embodiments of a low-profile, two-stage stent that can be used with any of the grafts of the present invention. The two stage stents of FIGS. 14 and 15 have the potential to reduce the amount of stent material, graft material and any adhesives in the proximal (and distal) neck portions of the graft while providing sufficient support to the graft body. Such a reduction of material provides a smaller profile graft. Consequently, a smaller profile delivery device may be used to access

smaller body lumens. While the following description focuses on the use of the stents with a proximal neck portion, it should be appreciated that such stents can also readily be used as a distal stent of an endovascular graft.

5 [0181] In general, the low-profile two stage stents are used with low-profile attachment anchors that are embedded or otherwise attached to a proximal neck of the endovascular graft and a low-profile distal stent. As illustrated in FIG. 14, stent 210 comprises a proximal stent 212 and a distal stent 214. Proximal stent 212 may be in the form of a serpentine ring that comprises a plurality of struts 216 that define crowns or apices 218. Similarly, distal stent 214 also may be in the shape of a serpentine ring that comprises strut 10 220 that define distal apices 222. In one configuration, proximal strut 216 will be wider than distal struts 220 such that the amount of material disposed in the proximal neck portion is reduced. In alternative configurations, the strut width of proximal stent 212 and distal stent 214 may be the same, if desired. As can be appreciated, the dimensions and configuration of the struts described above in relation to FIGS. 10-13 are also applicable to proximal stent 212 and distal stent 214. 15

[0182] In one configuration, proximal stent 212 may be coupled to a proximal end of a connector element 224 and distal stent 216 may be coupled to a distal end of connector element 224. Connector element 224 typically will be positioned adjacent a proximal edge 225 of a proximal neck portion 226 so as to minimize the overall neck portion 20 length of the endovascular graft. Proximal stent 212 typically will be configured to provide sufficient radial force to urge both connector member 224 and distal stent 214 against a surface of the body lumen wall. In one embodiment, distal stent 214 may be positioned along an outside surface of graft proximal neck portion 226. In other embodiments, however, distal stent 214 may be embedded within the graft proximal neck portion or disposed along an 25 inside surface of the graft neck portion.

[0183] Connector element 224 may be used to attach two-stage stent 210 to a connector member 228 that is attached to a proximal neck portion 226 of the endovascular graft. As described above, connector element 224 may be attached to a corresponding connector element (not shown) of connector member 228 with a coupling member 230. In 30 the illustrated embodiment, connector member is in the form of a plurality of discrete attachment anchors that are embedded in proximal neck portion 226 of the endovascular graft. In other embodiments, however, the connector member may take on other configurations.

[0184] The number of connector elements 224 will depend on the particular anchor shape and graft diameter, but it is contemplated that there will be between approximately four connector members and approximately ten connector members. It should be appreciated, however, that any number of connector members may be used with the present invention.

[0185] As previously discussed, the number of apices on proximal stent 212 and distal stent 214 may vary. One illustrative embodiment of a ratio of apices in proximal stent and distal stent is illustrated in FIG. 14 in which there are "n" connector elements 224. There will be between approximately "n" and approximately "3n" distal apices 222 (typically "2n" distal apices) in distal stent 214 and "n" proximal apices 218 in proximal stent 212. In other embodiments, however, there may be more proximal apices 218 (e.g., 2n or more). These ratios may vary as appropriate; these particular sets of ratios are merely illustrative. In the illustrated embodiment, there is a distal stent 214 connecting each adjacent anchor 228. In other configurations, however, there may only be a distal stent between every other anchor or the like.

[0186] FIG. 15 illustrates another embodiment of a two-stage stent 210. Proximal stent 212 and distal stent 214 will have substantially the same configuration as the stents in FIG. 14. For example, proximal stent 212 is coupled to a proximal end of a connector element 224 and distal stent 216 is coupled to a distal end of connector element 224. The primary difference between the embodiments is the use of a plurality of discrete V-shaped connector member elements 240 that are used to attach the proximal stent and distal stent to the graft proximal neck portion 226. Each end 242, 244 of V-shaped connector member element 240 comprises a connector element that may attach to connecting element 224 of the proximal stent 212 and distal stent 214. In the illustrated embodiment, however, the distal stents are positioned between adjacent V-shaped connector member elements 240 so as to keep the proximal neck portion against the body lumen wall.

[0187] In the illustrated embodiment, for every "n" connector elements 224 there will be "n/2" V-shaped connector member elements 240. For every space between the adjacent V-shaped connector member elements, a distal stent 214 may be positioned between and coupled to the connector elements of V-shaped connector member elements 240. The distal stents may have any number of distal crowns 222, but will typically have between "n" and "3n" distal crowns; preferably about "2n" distal crowns. In one embodiment, proximal stent 212 will have "n" proximal apices 218, but could have more proximal apices, if desired (e.g., 2n or more).

[0188] Proximal and distal stents 212, 214 may be manufactured from any conventional materials suitable for stents or connector members described herein. When manufactured from a shape memory alloy having superelastic properties such as NiTi, the stents may be configured to self-expand upon release from a constrained state.

5 [0189] While not shown, proximal stent 212 and/or distal stent 214 may take the shape of any of the stents described herein and may also comprise any combination of the barbs, tuck pads, or other elements of the stents described herein.

[0190] FIGS. 16A-16E illustrate an alternative cuff design that may be incorporated into any of the grafts of the present invention. For ease of reference only cuff 16 is illustrated in the figures. It should be appreciated, however, that the alternative cuff designs illustrated in FIGS. 16A-16E may be used in cuff 17, or any of the other cuffs described herein. As illustrated schematically by diameter D2 in FIG. 16A, the free size of graft body section proximal end 14 having an axisymmetric cuff (designated in FIG. 16A by reference numeral 16') may be designed to be larger than the diameter of the vessel or body lumen into which graft 10 is to be disposed to ensure a proper seal is formed to, for example, exclude the diseased aneurysmal vessel wall from blood flow. FIG. 16A illustrates graft body section proximal end 14 and associated inflated cuff 16' in a compressed when disposed against the inner wall of a blood vessel or other body lumen (not shown) having a diameter D1. Note the flattened inflated profile of cuff 16' as compared to that of cuff 16, indicating sealing apposition to the vessel wall.

10
15
20

[0191] Although the design of cuff 16, 16' (and cuff 17) shown in FIGS. 1 and 16A, cuffs 56, 57 of FIG. 2, and cuffs 111, 117 and 119 of FIG. 7 has proved clinically successful in providing a highly reliable fluid seal as described herein, compression of the inflated cuffs against the vessel or body lumen wall to create that seal has the potential to produce folds in the cuffs due to the membrane nature of the cuff construction (described in more detail in co-pending U.S. Patent Application Serial Nos. 10/029,570, 10/029,584, and 10/029,557). FIG 16B schematically illustrates a transverse cross section of the idealized graft portion of FIG. 16A demonstrating conceptually how such folds or buckles 31 may occur in the outer surface of the inflated cuff when the graft is disposed *in vivo* (shown by solid outline D1) compared to that surface when the cuff is inflated in free space (shown by dotted outline D2). These folds or buckles 31 have been demonstrated in various laboratory experiments, and have the potential to create undesirable fluid leaks through the seal.

25
30

[0192] An alternative cuff design that addresses the possibility of such folds or buckles 31 is shown in the FIGS. 16C and 16D idealized schematic view of a proximal end

14 of graft body section 13 in which cuffs 16 take on a non-cylindrically symmetric, zig-zag or serrated shape. This optional configuration provides the intended sealing function when the cuffs are inflated but is less sensitive to folding that may occur due to diametric interference of cuff 16 with the vessel or body lumen wall. As shown schematically in FIGS.

5 16C and 16D, one embodiment of serrated cuff 16 may reduce the potential in-folding of graft 10 through the ability of cuff apices 19 to act as a hinge, thus accommodating, for example, a graft diameter reduction from that of FIG. 16C to that of FIG. 16D.

[0193] FIG. 16E further illustrates how serrated cuff 16 may be designed to minimize in-folding. Here an inner radius of curvature R1 is offset in a direction towards the
10 outer radius of curvature R2 in apices 19. Offsetting inner radius of curvature R1 in this fashion allows R1 to be larger than it otherwise would be without an offset, which in turn produces less strain in the apices 19 for the same angular change of the “hinge” at apices 19 and a concomitant lower potential that the membrane hinge or apex 19 will experience an undesirable in-fold. This alternative serrated cuff design of FIGS. 16C-16E may also
15 advantageously enhance the kink resistance of the graft of the present invention, as the prevention of longitudinal graft body folds by the hinging action of apices 19 tends to also prevent the initiation of undesirable kinks in graft body 13.

[0194] Useful inflation media generally include those formed by the mixing of multiple components and that have a cure time ranging from a few minutes to tens of
20 minutes, preferably from about three and about twenty minutes. Such a material should be biocompatible, exhibit long-term stability (preferably on the order of at least ten years *in vivo*), pose as little an embolic risk as possible, and exhibit adequate mechanical properties, both pre- and post-cure, suitable for service in the graft of the present invention *in vivo*. For instance, such a material should have a relatively low viscosity before solidification or curing
25 to facilitate the graft cuff and channel fill process. A desirable post-cure elastic modulus of such an inflation medium is from about 50 to about 400 psi – balancing the need for the filled graft to form an adequate seal *in vivo* while maintaining clinically relevant kink resistance of the graft. The inflation media ideally should be radiopaque, both acute and chronic, although this is not absolutely necessary.

30 [0195] Details of compositions suitable for use as an inflation medium in the present invention are described in greater detail in U.S. Patent Application Serial No. 09/496,231 to Hubbell et al., filed February 1, 2000 and entitled “Biomaterials Formed by Nucleophilic Addition Reaction to Conjugated Unsaturated Groups” and U.S. Patent Application Serial No. 09/586,937 to Hubbell et al., filed June 2, 2000 and entitled

“Conjugate Addition Reactions for the Controlled Delivery of Pharmaceutically Active Compounds”. The entirety of each of these patent applications is hereby incorporated herein by reference.

5 [0196] We have found one particular three-component medium formed by the Michael addition process to be particularly useful in serving as an inflation medium for the present invention. This medium comprises:

- (1) polyethylene glycol diacrylate (PEGDA), present in a proportion ranging from about 50 to about 55 weight percent; specifically in a proportion of about 52 weight percent,
- 10 (2) pentaerythritol tetra 3(mercaptopropionate) (QT) present in a proportion ranging from about 22 to about 27 weight percent; specifically in a proportion of about 24 weight percent, and
- (3) glycylglycine buffer present in a proportion ranging from about 22 to about 27 weight percent; specifically in a proportion of about 24 weight percent.

15 [0197] Variations of these components and other formulations as described in copending U.S. Patent Application Serial Nos. 09/496,231 and 09/586,937, both to Hubbell et al., may be used as appropriate. In addition, we have found PEGDA having a molecular weight ranging from about 350 to about 850 to be useful; PEGDA having a molecular weight ranging from about 440 to about 560 are particularly useful.

20 [0198] Radiopaque materials as previously discussed may be added to this 3-component system. We have found that adding radiopacifiers such as barium sulfate, tantalum powder, and soluble materials such as iodine compounds to the glycylglycine buffer is useful.

25 [0199] We have found that triethanolamine in phosphate-buffered saline may be used as an alternative to glycylglycine buffer as the third component described above to form an alternative curable gel suitable for use in embodiments of the present invention.

30 [0200] An alternative to these three-component systems is a gel made via polymer precipitation from biocompatible solvents. Examples of such suitable polymers include ethylene vinyl alcohol and cellulose acetate. Examples of such suitable biocompatible solvents include dimethylsulfoxide (DMSO), n-methyl pyrrolidone (NMP) and others. Such polymers and solvents may be used in various combinations as appropriate.

[0201] Alternatively, various siloxanes may be used as inflation gels.

Examples include hydrophilic siloxanes and polyvinyl siloxanes (such as STAR-VPS from Danville Materials of San Ramon, California and various silicone products such as those manufactured by NuSil, Inc. of Santa Barbara, California).

5 [0202] Other gel systems useful as an inflation medium or material for the present invention include phase change systems that gel upon heating or cooling from their initial liquid or thixotropic state. For example, materials such as n-isopropyl-polyacrylimide (NIPAM), BASF F-127 pluronic polyoxymer, and polyethylene glycol (PEG) chemistries having molecular weights ranging between about 500 and about 1,200 are suitable.

10 [0203] Effective gels may also comprise thixotropic materials that undergo sufficient shear-thinning so that they may be readily injected through a conduit such as a delivery catheter but yet still are able to become substantially gel-like at zero or low shear rates when present in the various channels and cuffs of the present invention.

[0204] In the case of the three-component PEDGA-QT-glycylglycine
15 formulation described above, a careful preparation and delivery protocol should be followed to ensure proper mixing, delivery, and ultimately clinical efficacy. Each of the three components is typically packaged separately in sterile containers such as syringes until the appropriate time for deploying the endovascular graft. The QT and buffer (typically glycylglycine) are first continuously and thoroughly mixed, typically between their respective
20 syringes for approximately two minutes. PEGDA is then mixed thoroughly with the resulting two-component mixture for approximately three minutes. This resulting three-component mixture is then ready for introduction into the graft body section as it will cure into a gel having the desired properties within the next several minutes. Cure times may be tailored by adjusting the formulations, mixing protocol, and other variables according to the
25 requirements of the clinical setting. Details of suitable delivery protocols for these materials are discussed in copending U.S. Patent Application Serial No. 09/917,371 to Chobotov et al.

[0205] We have found the post-cure mechanical properties of these gels to be highly tailorable without significant changes to the formulation. For instance, these gels may exhibit moduli of elasticity ranging from tens of psi to several hundred psi; the formulation
30 described above exhibits moduli ranging from about 175 to about 250 psi with an elongation to failure ranging from about 30 to about 50 percent.

[0206] Notably, we have found it helpful to add an inert biocompatible material to the inflation material. In particular, we have found that adding a fluid such as saline to the PEGDA-QT-glycylglycine formulation (typically after it has been mixed but

before significant curing takes place) lowers the viscosity of the formulation and results in greater ease when injecting the formulation into the graft body section network of inflatable cuffs and channels without sacrificing the desired physical, chemical, and mechanical properties of the formulation or its clinical efficacy. In the appropriate volume percentages, adding materials such as saline may also reduce the potential for the inflation material such as PEGDA-QT-glycylglycine to pose an embolic risk in case of spillage or leakage. Saline concentrations as a volume percentage of the final saline/three-component formulation combination may range from zero to as high as sixty percent or more; particularly suitable are saline concentrations ranging from about twenty to about forty percent. We have found a saline volume concentration of about thirty percent to be most suitable. Alternatives to saline may include biocompatible liquids, including buffers such as glycylglycine.

[0207] In more general terms, it is desirable to use an inflation medium in which each of its components is biocompatible and soluble in blood. A biocompatible inflation medium is desirable so to manage any toxicity risk in the case the inflation medium were inadvertently released into the patient's vasculature. A soluble inflation medium is desirable so to manage any embolism risk if released into the vasculature. Such an inflation medium should not disperse nor gel or solidify if spilled into flowing blood before curing. In the event of a spill, the normal blood flow would then rapidly disperse the components and their concentration would fall below the level required for crosslinking and formation of a solid. These components would then be eliminated by the body through standard pathways without posing an embolic risk to the patient. Among the many possibilities of an inflation medium example in which all of the components are soluble in blood is the combination polyethylene glycol diacrylate, a thiolated polyethylenamine, and a buffer.

[0208] As previously discussed, more than one type of inflation medium, or more than one variant of a single type of inflation medium may be used in a single graft to optimize the graft properties in the region in which it is disposed.

[0209] For example, in the proximal and distal cuffs of the various embodiments of the present invention, the inflation material serves as a conformable sealing medium to provide a seal against the lumen wall. Desirable mechanical characteristics for the inflation medium in the proximal and distal cuffs would therefore include a low shear strength so to enable the cuff to deform around any luminal irregularities (such as calcified plaque asperities) and to conform to the luminal profile, as well as a high volumetric compressibility to allow the fill material to expand the cuffs as needed to accommodate any late lumen dilatation and maintain a seal.

[0210] In the channel or channels, by contrast, the inflation medium serves primarily to provide structural support to the lumen within which the graft is placed and kink resistance to the graft. Desirable mechanical characteristics for the inflation medium in the channel or channels therefore includes a high shear strength, to prevent inelastic deformation of a channel or channel segment due to external compression forces from the vessel or lumen (due, for example, to neointimal hyperproliferation) and low volumetric compressibility to provide stable support for adjacent channels or channel segments that may be in compressive contact with each other, thereby providing kink resistance to the graft.

[0211] Given these contrasting requirements, it may be useful to have different inflation materials fill different portions of the graft, such as one inflation medium for the proximal and distal cuffs and a second in the channel or channels.

[0212] In the various embodiments of the present invention, it is desirable that the inflation medium be visible through the use of techniques such as fluoroscopy during the time of deployment in which the graft cuffs and channels are being filled with the inflation medium. Such visibility allows the clinician to verify that the cuffs and channels are filling correctly and to adjust the filling procedure if they are not. It also provides an opportunity to detect any leakage or otherwise undesirable flow of inflation material out of the graft so that injection may be stopped, thereby minimizing the amount of leaked inflation material.

[0213] After the graft has been deployed into a patient, it is desirable that the graft be visible through the use of follow-up imaging techniques such as computed tomography (CT) and the like. However, the inflation material at this point in time is ideally not so radiopaque that it produces a dense CT image as such an image could potentially mask clinically significant endoleaks that would be visualized by opacifying the blood with a contrast agent.

[0214] Balancing these two objectives is difficult, however, since CT techniques are much more sensitive in detecting small amounts of radiopaque matter than are fluoroscopy techniques. One solution is to use an inflation medium that becomes less radiopaque over time, such as for example by using a blend of radiopaque materials in which one or more will diffuse out of the inflation medium over time, thereby reducing the inflation medium's radiopacity. For instance, a blend of a soluble contrast agent such as an iodinated aqueous solution and an insoluble contrast agent such as barium sulfate may serve this purpose. The soluble contrast agent will diffuse through the graft body section pores some time after the graft has been implanted, resulting in a progressive decrease in radiopacity of the inflation material over time. A fill material radiopacifier prepared from a combination of

about two percent barium sulfate (by weight) and about 20 percent iodinated contrast solution (by weight) is useful in this capacity.

[0215] While particular forms of the invention have been illustrated and described, it will be apparent that various modifications can be made without departing from
5 the spirit and scope of the invention.

WHAT IS CLAIMED IS:

- 1 1. An endovascular graft comprising:
2 a graft body section having a proximal end and a distal end;
3 a connector member affixed to the proximal end of the graft body section, the
4 connector member comprising one or more connector elements; and
5 a proximal stent comprising one or more proximal stent connector elements
6 coupled to the one or more connector member connector elements.

- 1 2. The endovascular graft of claim 1 wherein the connector member is
2 embedded within the graft body section.

- 1 3. The endovascular graft of claim 1 further comprising one or more coupling
2 members, wherein:
3 the one or more connector member connector elements comprise a proximal
4 end and a distal end and shoulder portions at the proximal and distal ends;
5 the one or more proximal stent connector elements comprise a proximal end
6 and a distal end and shoulder portions at the proximal and distal ends; and
7 the one or more coupling members couple the one or more connector member
8 connector elements to the one or more proximal stent connector elements.

- 1 4. The endovascular graft of claim 3 wherein the coupling member is a wire
2 coil.

- 1 5. The endovascular device of claim 1 wherein the connector member
2 comprises a serpentine ring comprising apices.

- 1 6. The endovascular graft of claim 1 wherein the connector member
2 comprises one or more discrete connector member elements.

- 1 7. The endovascular graft of claim 6 wherein one or more of the connector
2 member elements comprise nitinol.

- 1 8. The endovascular graft of claim 6 wherein the connector member elements
2 numbers between approximately four and approximately ten.

1 9. The endovascular graft of claim 6 wherein at least one of the connector
2 member elements comprise an elongated proximal portion and an enlarged distal portion.

1 10. The endovascular graft of claim 6 wherein at least one of the connector
2 member elements are V-shaped.

1 11. The endovascular device of claim 1 wherein the proximal stent comprises
2 a serpentine ring comprising apices.

1 12. The endovascular device of claim 1 wherein:
2 the connector member comprises a serpentine ring comprising apices, wherein
3 the number of connector member apices is n ; and
4 the proximal stent comprises a serpentine ring comprising apices, wherein the
5 number of proximal stent apices is $n/2$.

1 13. The endovascular device of claim 1 wherein:
2 the connector member comprises a serpentine ring comprising apices, wherein
3 the number of connector member apices is n ; and
4 the proximal stent comprises a first region and a second region, the first and
5 second regions each comprising a serpentine ring having apices, and wherein the number of
6 connector member apices is n , the number of proximal stent first region apices is $n/2$ and the
7 number of proximal stent second region apices is $n/4$.

1 14. The endovascular graft of claim 1 further comprising a distal connector
2 member affixed to the distal end of the graft body section and a distal stent affixed to the
3 distal connector member.

1 15. The endovascular graft of claim 1 wherein the proximal stent further
2 comprises one or more integrally formed barbs.

1 16. The endovascular graft of claim 14 wherein the distal stent further
2 comprises one or more integrally formed barbs.

1 17. The endovascular graft of claim 16 wherein the one or more integrally
2 formed barbs are oriented proximally.

1 18. The endovascular graft of claim 15 wherein the one or more barbs are
2 oriented distally.

1 19. The endovascular graft of claim 16 wherein the proximal stent further
2 comprises one or more barbs and wherein the one or more proximal stent barbs are oriented
3 distally and wherein the one or more distal stent barbs are oriented proximally.

1 20. The endovascular graft of claim 19 wherein the one or more proximal stent
2 barbs or the one or more distal stent barbs have a length from about 2 mm to about 4 mm.

1 21. The endovascular graft of claim 1 wherein an inflatable cuff is disposed at
2 the proximal end of the graft body section.

1 22. The endovascular graft of claim 21 wherein an inflatable cuff is disposed
2 at the distal end of the graft body section.

1 23. The endovascular graft of claim 1 wherein the graft body section
2 comprises an inflatable channel.

1 24. The endovascular graft of claim 23 wherein the inflatable channel is
2 disposed in a helical configuration along the graft body section.

1 25. The endovascular graft of claim 24 wherein the inflatable channel
2 comprises a plurality of circumferential rings and a spine that is in fluid communication with
3 the plurality of circumferential rings.

1 26. The endovascular graft of claim 21 wherein the graft body section
2 comprises an inflatable channel.

1 27. The endovascular graft of claim 21 wherein at least one of the inflatable
2 cuff and the inflatable channel contains an inflation medium.

1 28. The endovascular graft of claim 27 wherein the inflation medium is a
2 curable biocompatible material having a cure time from about three to about twenty minutes
3 and a post-cure elastic modulus from about 50 to about 400 psi.

1 29. An endovascular graft comprising:
2 a graft body section having a proximal end and a distal end;

3 a proximal stent affixed to the graft body section proximal end, the proximal
4 stent comprising one or more barbs and one or more barb tuck pads configured to retain the
5 one or more barbs when the proximal stent is in a delivery configuration.

1 30. The endovascular graft of claim 29 wherein the one or more barbs and
2 tuck pads are integrally formed with the proximal stent and wherein the one or more barbs are
3 released by the one or more barb tuck pads when the proximal stent is in a deployed
4 configuration.

1 31. The endovascular graft of claim 29 wherein the one or more barbs have a
2 length from about 1 to about 5 mm.

1 32. The endovascular graft of claim 29 wherein the one or more barbs have a
2 length from about 2 to about 4 mm.

1 33. The endovascular graft of claim 29 wherein the one or more barbs are
2 oriented distally.

1 34. The endovascular graft of claim 29 wherein the one or more barbs project
2 radially outward from a longitudinal axis of the proximal stent and form a barb radial angle
3 from about 10 to about 45 degrees with respect a proximal neck portion inlet axis, when the
4 proximal stent is deployed *in vivo*.

1 35. The endovascular graft of claim 34 wherein the one or more barbs are
2 laterally biased in a plane that is orthogonal to a plane in which the barb radial angle is
3 formed to form a barb kick angle.

1 36. The endovascular graft of claim 29 wherein the proximal stent further
2 comprises one or more barb tuck slots and wherein the one or more barbs are received by the
3 one or more slots when the proximal stent is in a delivery configuration and the one or more
4 barbs are released from the one or more slots when the proximal stent is in a deployed
5 configuration.

1 37. The endovascular graft of claim 36 wherein the one or more barbs have a
2 length from about 2 to about 4 mm, are oriented in a distal direction, and project radially
3 outward from a longitudinal axis of the proximal stent and form an angle from about 10 to

4 about 45 degrees with respect to a proximal neck portion inlet axis, when the proximal stent
5 is deployed *in vivo*.

1 38. The endovascular graft of claim 29 wherein an inflatable cuff is disposed
2 at the proximal end of the graft body section.

1 39. The endovascular graft of claim 38 wherein the graft body section
2 comprises an inflatable channel.

1 40. The endovascular graft of claim 39 wherein an inflatable cuff is disposed
2 at the distal end of the graft body section.

1 41. The endovascular graft of claim 38 wherein the inflatable cuff contains an
2 inflation medium.

1 42. The endovascular graft of claim 41 wherein the inflation medium is a
2 curable biocompatible material having a cure time from about three to about twenty minutes
3 and a post-cure elastic modulus from about 50 to about 400 psi.

1 43. An inflation medium for use in an inflatable medical device comprising a
2 low-viscosity curable biocompatible material having a cure time from about three to about
3 twenty minutes and a post-cure elastic modulus from about 50 to about 400 psi.

1 44. The inflation medium of claim 43 wherein the inflation medium is
2 radiopaque.

1 45. An endovascular graft comprising:
2 a main body portion,
3 a first bifurcated portion forming a continuous lumen with the main body
4 portion, said lumen configured to confine a flow of fluid therethrough,
5 at least one inflatable channel extending from the first bifurcated portion to the
6 main body portion and containing an inflation medium,
7 at least one inflatable cuff disposed at a proximal end of the main body portion
8 in fluid communication with the at least one channel and containing the inflation medium.

1 46. The endovascular graft of claim 45 wherein the inflation medium is diluted
2 with saline.

1 47. The endovascular graft of claim 46 wherein the inflation medium
2 comprises between about twenty and about forty percent by volume saline.

1 48. The endovascular graft of claim 45 wherein the inflation medium is a
2 curable biocompatible material having a cure time of about three to about twenty minutes and
3 a post-cure elastic modulus from about 50 to about 400 psi.

1 49. An endovascular graft comprising:
2 a main body portion with a distal end and a proximal end with an connector
3 member disposed on the proximal end, the connector member comprising one or more
4 connector elements;
5 a proximal stent comprising one or more proximal stent connector elements,
6 wherein the one or more proximal stent connector elements are coupled to the one or more
7 connector member connector elements; and
8 a first bifurcated portion and a second bifurcated portion forming a continuous
9 lumen with the main body portion, said lumen configured to confine a flow of fluid
10 therethrough.

1 50. The graft of claim 49 wherein the proximal stent further comprises one or
2 more integrally formed barbs.

1 51. The graft of claim 50 wherein the one or more barbs are oriented distally.

1 52. The graft of claim 50 wherein the one or more barbs have a length from
2 about 1 to about 5 mm.

1 53. The graft of claim 50 wherein the one or more barbs project radially
2 outward from a longitudinal axis of the proximal stent and form a barb radial angle from
3 about 10 to about 45 degrees with respect to a proximal neck portion inlet axis, when the
4 proximal stent is deployed in vivo.

1 54. The graft of claim 53 wherein the one or more barbs are laterally biased in
2 a plane that is orthogonal to a plane in which the barb radial angle is formed to form a barb
3 kick angle.

1 55. The graft of claim 49 further comprising a distal connector member
2 disposed at a distal end of the first bifurcated portion and a distal stent coupled to the distal
3 connector member.

1 56. The graft of claim 55 wherein a second distal connector member is
2 disposed at the distal end of the second bifurcated portion and a second distal stent is coupled
3 to the second distal connector member.

1 57. The graft of claim 56 wherein the at least one of the first and second distal
2 stents further comprises one or more integrally formed barbs.

1 58. The graft of claim 57 wherein the one or more barbs are oriented
2 proximally.

1 59. The graft of claim 57 wherein the one or more barbs have a length from
2 about 1 mm to about 5 mm.

1 60. The graft of claim 57 wherein the one or more barbs project radially
2 outward from a longitudinal axis of the at least one of the first and second distal stents and
3 form a barb radial angle from about 10 to about 45 degrees with respect to a distal stent strut
4 longitudinal axis.

1 61. The endovascular graft of claim 60 wherein the one or more barbs are
2 laterally biased in a plane that is orthogonal to a plane in which the barb radial angle is
3 formed to form a barb kick angle.

1 62. A system for use in implanting a tubular medical device within a body
2 lumen having a wall, said system comprising:
3 a stent for affixing the medical device to the lumen wall; and
4 a connector member for coupling the stent to the medical device, wherein the
5 stent and connector member are coupled to one another by at least one set of connector
6 elements.

1 63. The system of claim 62 wherein the stent further comprises one or more
2 barbs.

1 64. The system of claim 63 wherein the stent further comprises one or more
2 barb tuck pads and wherein the one or more barbs are configured to be retained by the barb
3 tuck pads when the system is in a delivery configuration and released by the one or more barb
4 tuck pads when the system is in a deployed configuration.

1 65. The system of claim 64 wherein the stent further comprises slots and
2 wherein the barbs are configured to be received by the slots when the system is in a delivery
3 configuration and configured to be released from the slots when the system is in a deployed
4 configuration.

1 66. The system of claim 64 wherein the one or more barbs have a length from
2 about 1 to about 5 mm.

1 67. The system of claim 64 wherein the one or more barbs project radially
2 outward from a strut of the stent.

1 68. The system of claim 67 wherein the one or more barbs are laterally biased
2 in a plane that is orthogonal to a plane in which the barb radially projects.

1 69. An endovascular graft comprising:
2 a graft body section having a proximal end and a distal end;
3 a proximal connector member affixed to the proximal end of the graft body
4 section, the proximal connector member comprising one or more connector elements;
5 a proximal stent comprising one or more distally oriented barbs and
6 comprising one or more proximal stent connector elements coupled to the one or more
7 proximal connector member connector elements,
8 a distal connector member affixed to the distal end of the graft body section,
9 the distal connector member comprising one or more connector elements,
10 a distal stent comprising one or more proximally oriented barbs and
11 comprising one or more distal stent connector elements coupled to the one or more distal
12 connector member connector elements,
13 an inflatable cuff disposed at each of the proximal and distal ends of the graft
14 body section, and wherein the graft body section comprises an inflatable channel in fluid
15 communication with the proximal and distal cuffs.

1 70. The endovascular graft of claim 69 further comprising one or more
2 coupling members, wherein:

3 the one or more proximal connector member connector elements and the one
4 or more distal connector member connector elements each comprises a proximal end and a
5 distal end and wherein opposing shoulder portions are disposed at each of the proximal and
6 distal ends;

7 the one or more proximal stent connector elements and the one or more distal
8 stent connector elements each comprises a proximal end and a distal end and wherein
9 opposing shoulder portions are disposed at each of the proximal and distal ends;

10 the one or more coupling members couple the one or more proximal connector
11 member connector elements to the one or more proximal stent connector elements; and

12 the one or more coupling members couple the one or more distal connector
13 member connector elements to the one or more distal stent connector elements.

1 71. The endovascular graft of claim 69 wherein the at least one of the
2 inflatable channel, the distal inflatable cuff, and the proximal inflatable cuff contains an
3 inflation medium.

1 72. The endovascular graft of claim 69 wherein the graft body section
2 comprises ePTFE.

1 73. The endovascular graft of claim 69 wherein the one or more proximal stent
2 barbs or the one or more distal stent barbs are integrally formed with their respective stents
3 and have a length from about 1 mm to about 5 mm.

1 74. An endovascular graft comprising:

2 a main body portion with a distal end and a proximal end with a connector
3 member disposed on the proximal end, the connector member comprising one or more
4 connector elements;

5 a proximal stent comprising one or more distally oriented barbs and
6 comprising one or more proximal stent connector elements, wherein the one or more
7 proximal stent connector elements are coupled to the one or more connector member
8 connector elements;

9 a first bifurcated portion and a second bifurcated portion forming a continuous
10 lumen with the main body portion, said lumen configured to confine a flow of fluid
11 therethrough;

12 a distal connector member disposed on distal ends of each of the first and
13 second bifurcated portions, the distal connector members each comprising one or more
14 connector elements,

15 one or more distal stents comprising one or more proximally oriented barbs
16 and comprising one or more distal stent connector elements, wherein the one or more distal
17 stent connector elements are coupled to the one or more distal connector member connector
18 elements on one or both of the first and second bifurcated portions;

19 at least one inflatable channel extending from one or both of the first and
20 second bifurcated portions to the main body portion;

21 at least one inflatable cuff disposed at a proximal end of the main body
22 portion; and

23 an inflatable cuff disposed at a distal end of one or both of the first and second
24 bifurcated portions, wherein

25 each of the at least one inflatable channel, at least one proximal inflatable cuff,
26 and distal inflatable cuffs are in fluid communication with each other.

1 75. The endovascular graft of claim 74 further comprising one or more
2 coupling members, wherein:

3 the one or more proximal connector member connector elements and the one
4 or more distal connector member connector elements each comprises a proximal end and a
5 distal end and wherein opposing shoulder portions are disposed at each of the proximal and
6 distal ends;

7 the one or more proximal stent connector elements and the one or more distal
8 stent connector elements each comprises a proximal end and a distal end and wherein
9 opposing shoulder portions are disposed at each of the proximal and distal ends;

10 the one or more coupling members couple the one or more proximal connector
11 member connector elements to the one or more proximal stent connector elements; and

12 the one or more coupling members couple the one or more distal connector
13 member connector elements to the one or more distal stent connector elements.

1 76. The endovascular graft of claim 74 wherein the wherein at least one of the
2 inflatable channel, the first bifurcated portion distal inflatable cuff, the second bifurcated
3 portion distal inflatable cuff and the proximal inflatable cuff contains an inflation medium.

1 77. The endovascular graft of claim 74 wherein the main body portion and the
2 first and second bifurcated portions comprises ePTFE.

1 78. The endovascular graft of claim 74 wherein the one or more proximal
2 stent barbs or the one or more distal stent barbs are integrally formed in their respective stents
3 and have a length from about 1 mm to about 5 mm.

1 79. An endovascular graft comprising:
2 a graft body comprising a proximal end and at least one distal end;
3 one or more connector member elements coupled to the at least one distal end
4 of the graft body, the one or more connector member elements comprising one or more
5 connector elements; and
6 at least one distal stent comprising one or more distal stent connector elements
7 that are configured to be coupled to the one or more connector elements.

1 80. The endovascular graft of claim 79 wherein the connector member
2 elements are at least partially embedded in at least one distal end of the graft body.

1 81. The endovascular graft of claim 79 wherein the number of connector
2 member elements is between approximately 4 and approximately 10.

1 82. The endovascular graft of claim 79 wherein the connector member
2 elements comprise a "T" configuration.

1 83. The endovascular graft of claim 79 wherein the connector member
2 elements comprise a "V" configuration.

1 84. The endovascular graft of claim 79 wherein the distal end of the graft
2 body is bifurcated.

1 85. The endovascular graft of claim 79 wherein the proximal stent
2 comprises at least one barb.

1 86. The endovascular graft of claim 79 further comprising an inflatable
2 cuff disposed on at least one of the proximal end and distal end of the graft body section.

1 87. The endovascular graft of claim 86 further comprising an inflatable
2 channel on the graft body section that is in fluid communication with the inflatable cuff.

1/22

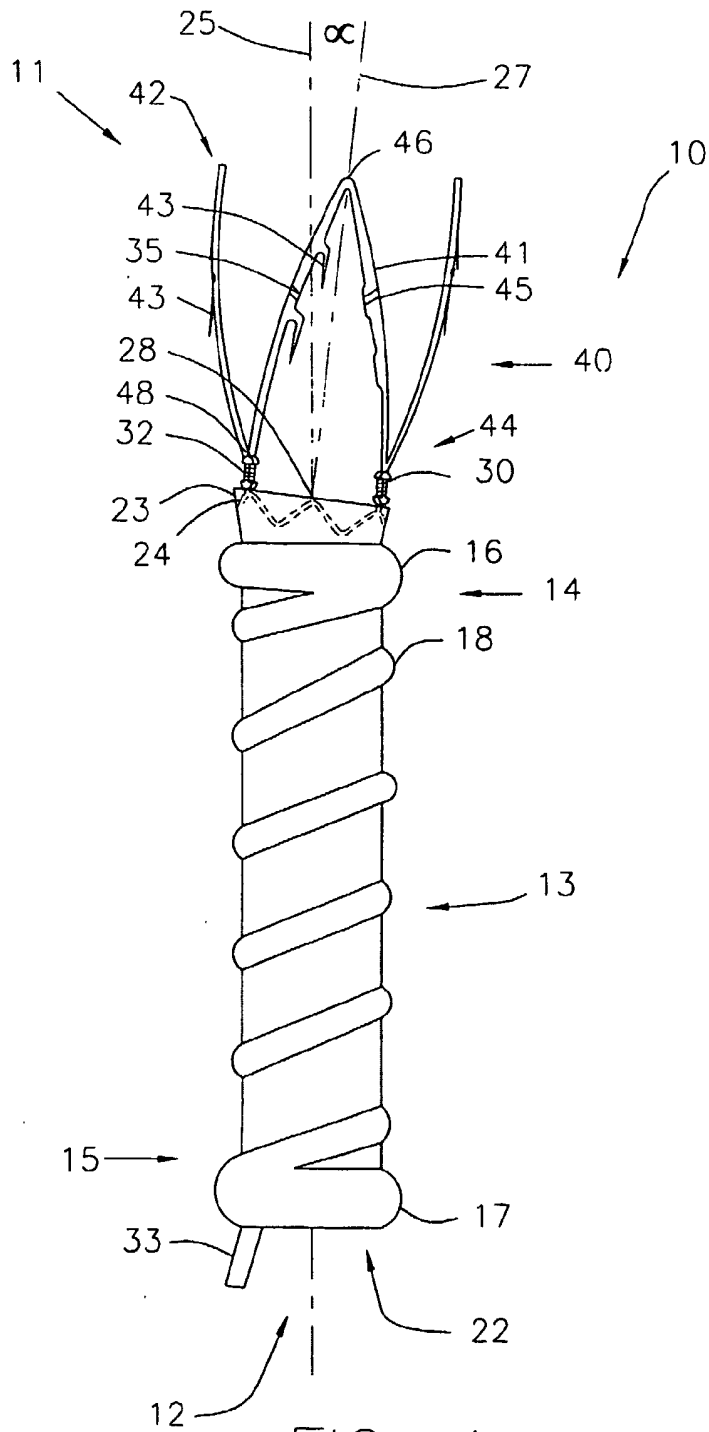

FIG. 1

2/22

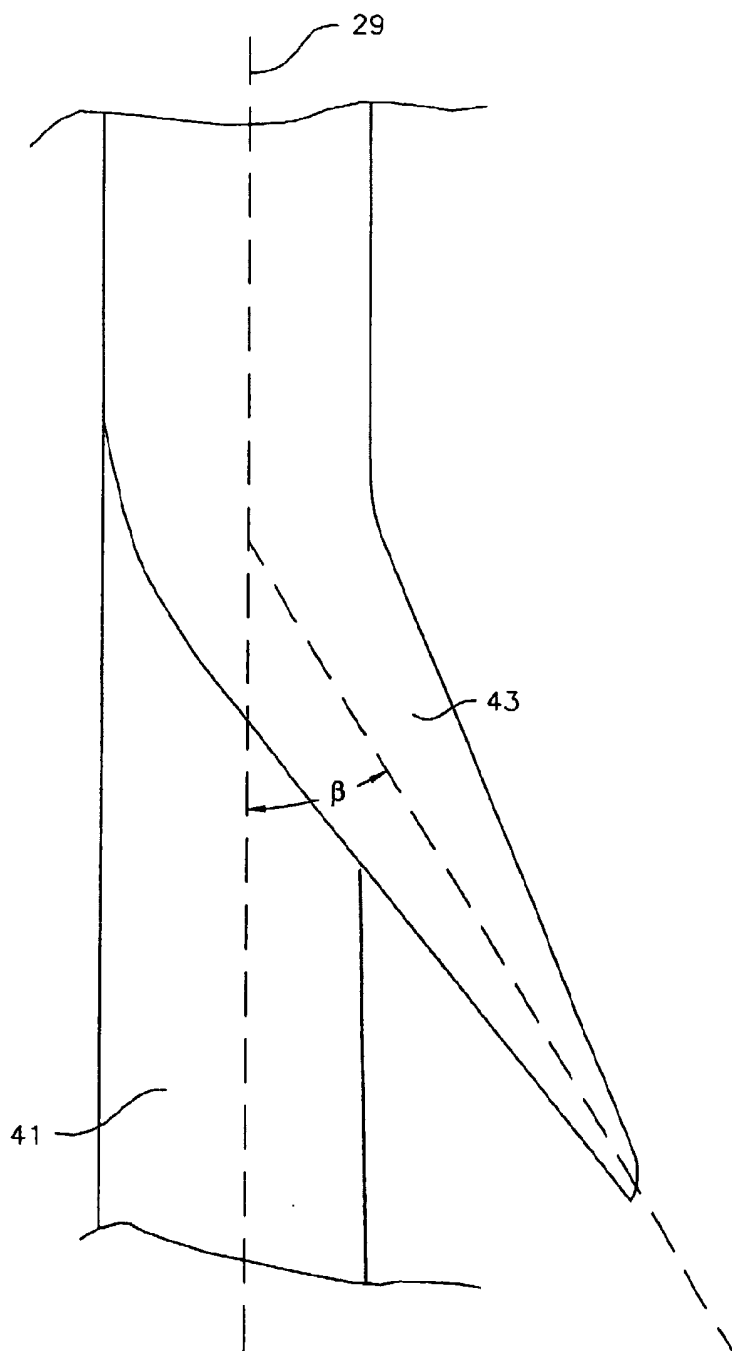

FIG. 1A

+

+

3/22

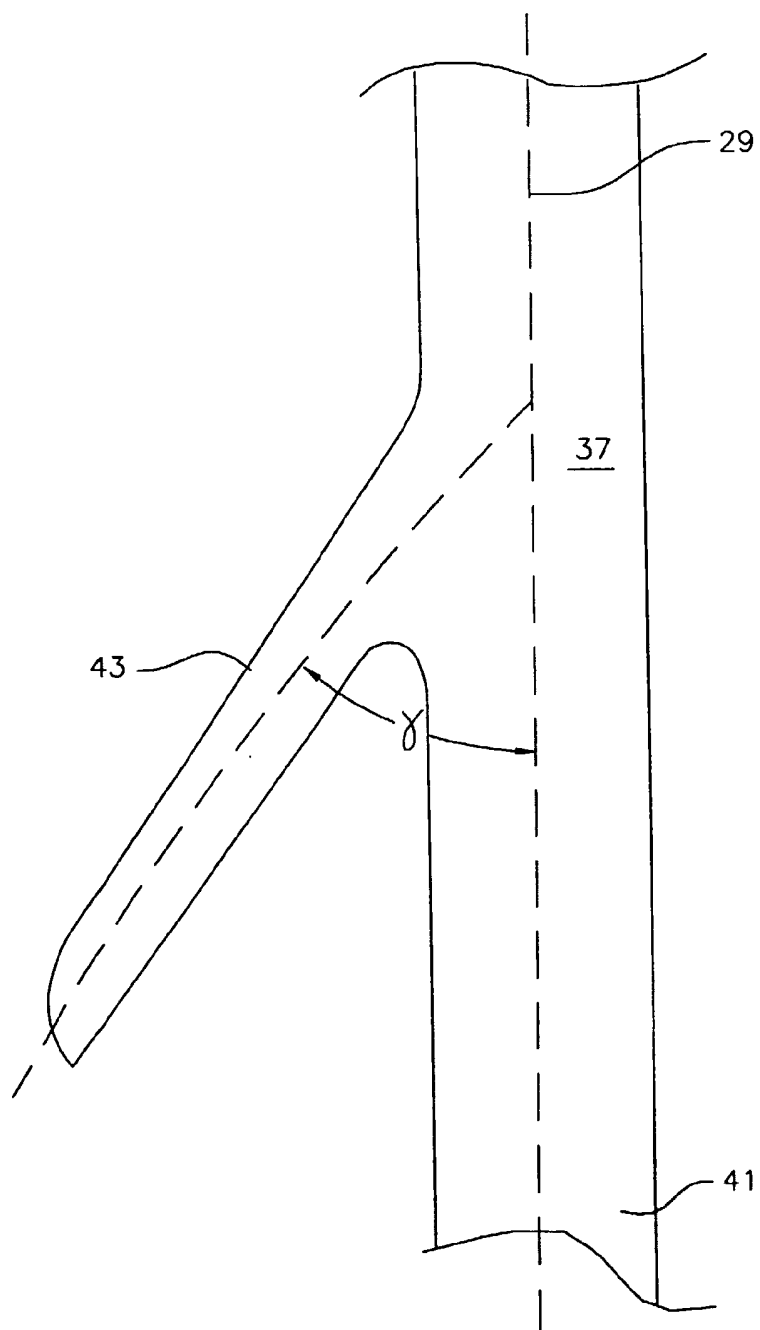

FIG. 1B

+

+

4/22

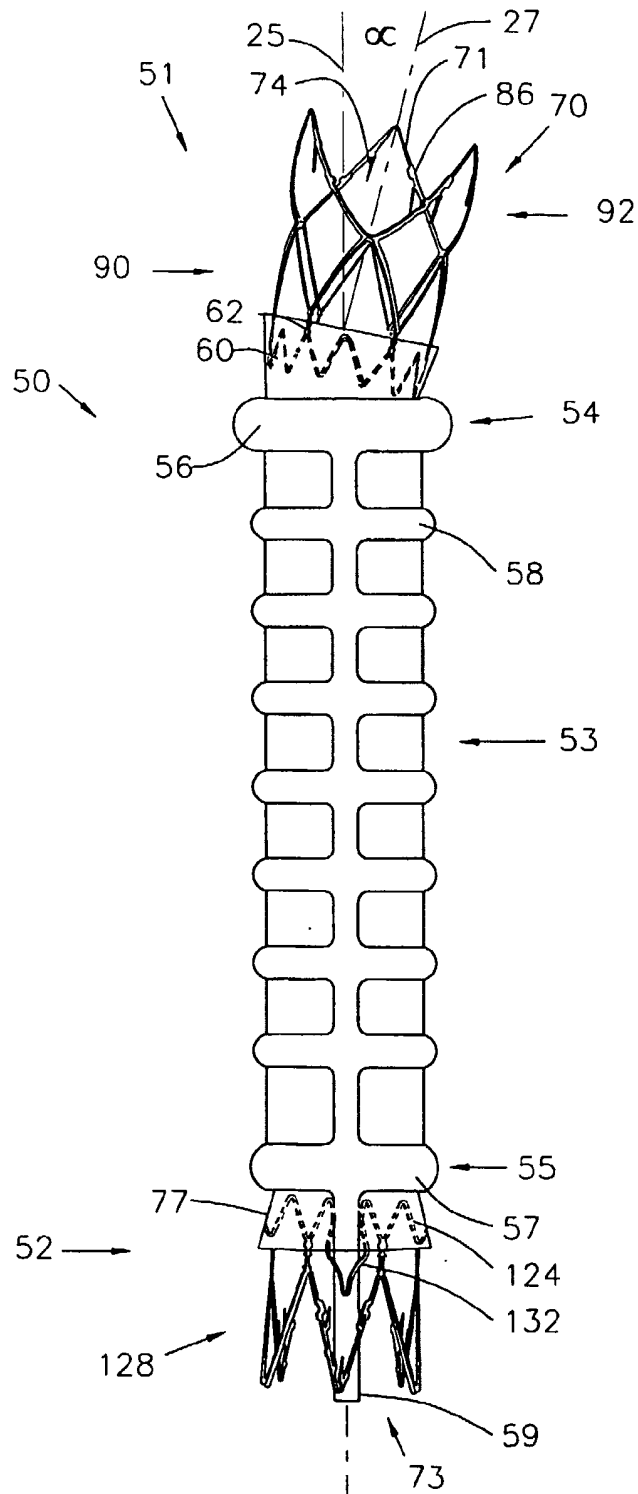

FIG. 2

+

5/22

+

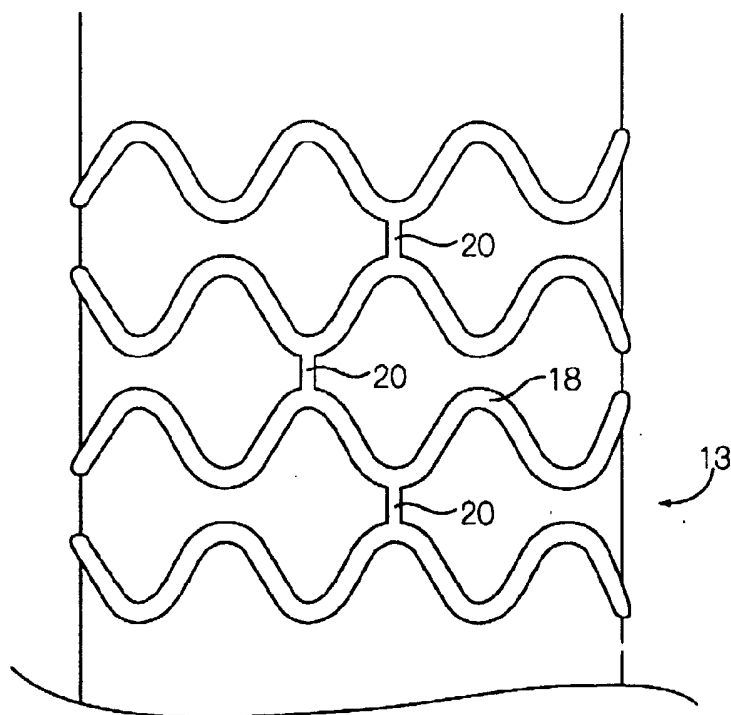

FIG. 2A

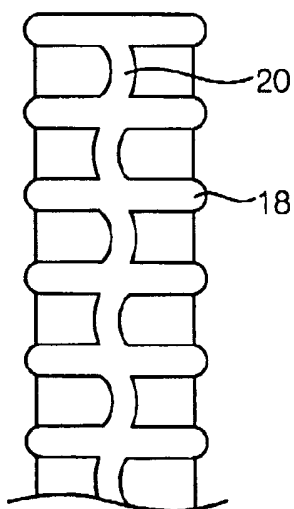

FIG. 2B

6/22

+

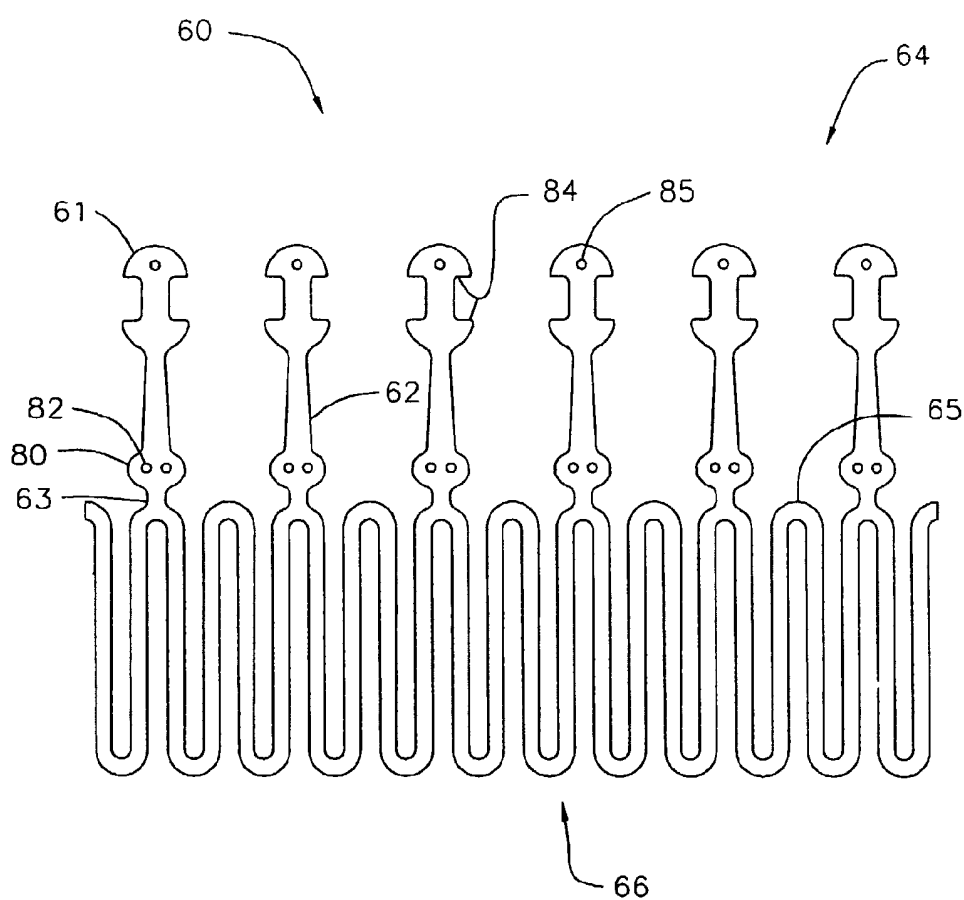

FIG. 3A

+

7/22

+

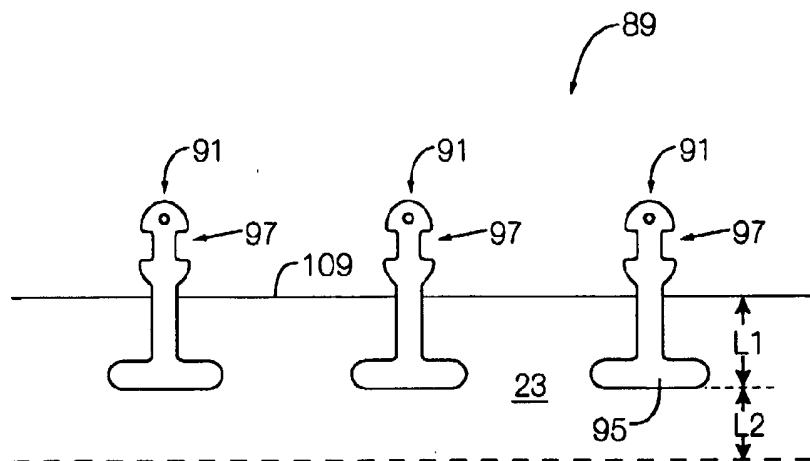

FIG. 3B

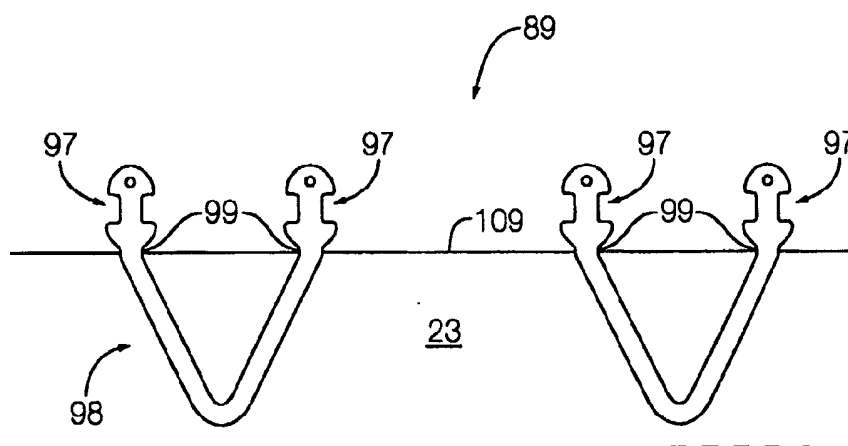

FIG. 3D

8/22

+

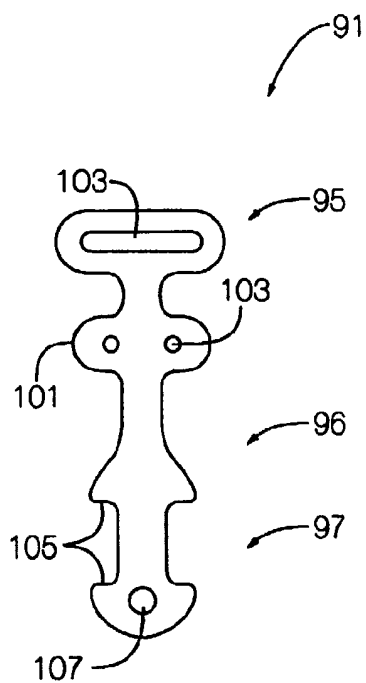

FIG. 3C

9/22

+

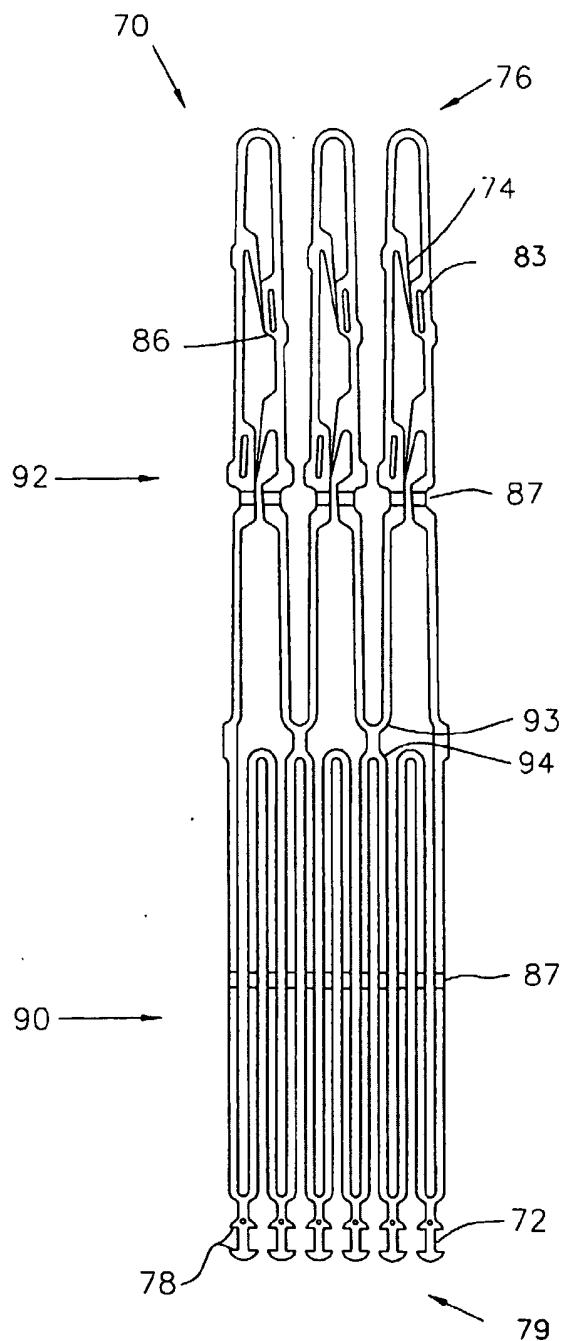

FIG. 4

+

10/22

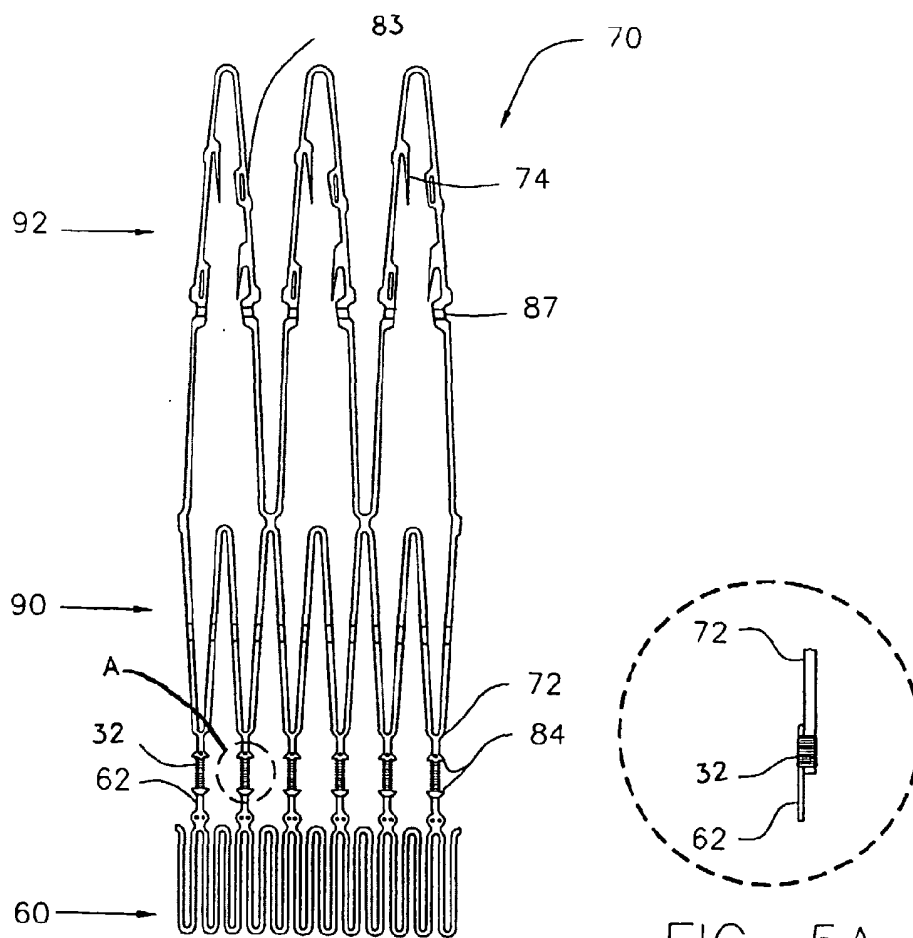

FIG. 5A

+

11/22

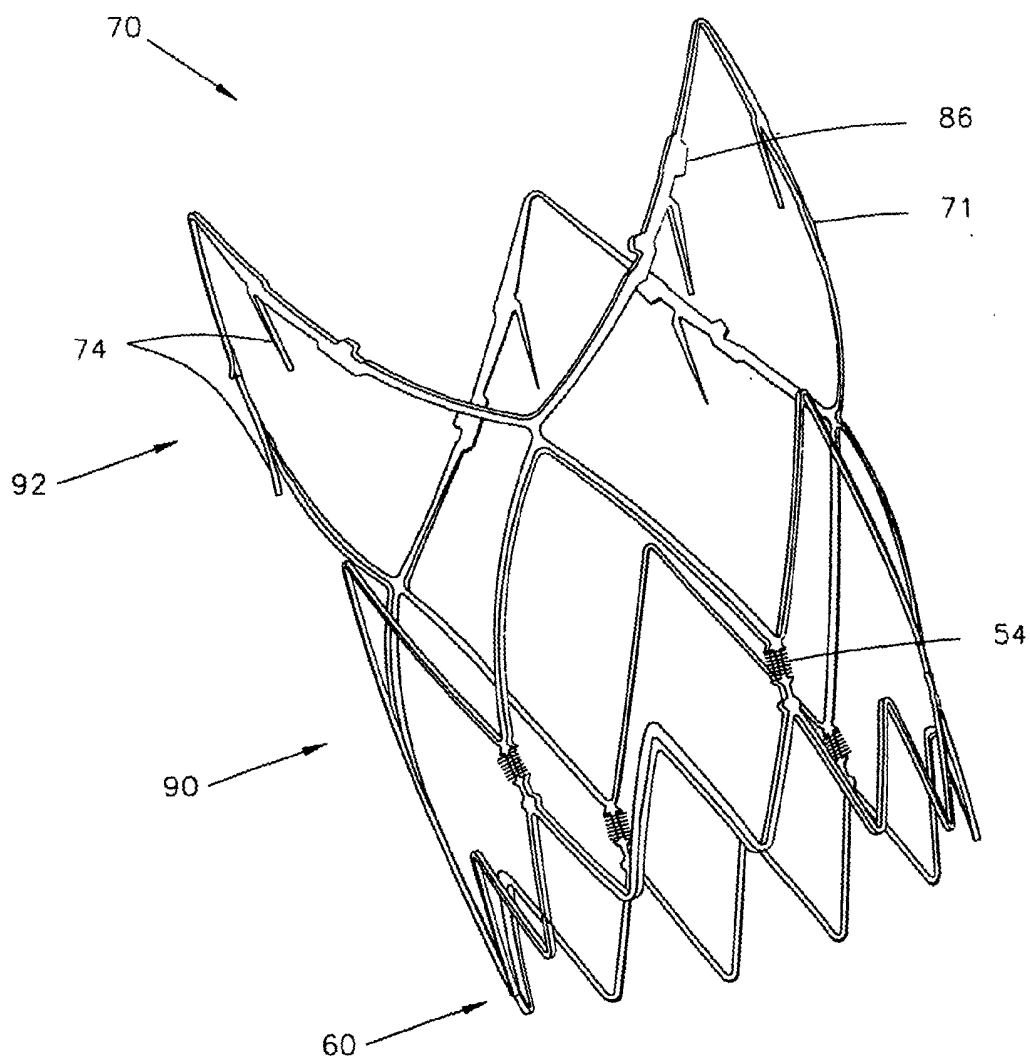

FIG. 6

+

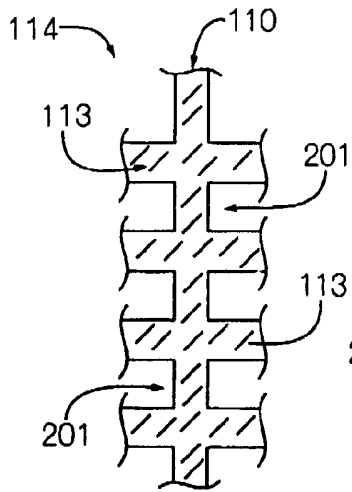

FIG. 7A

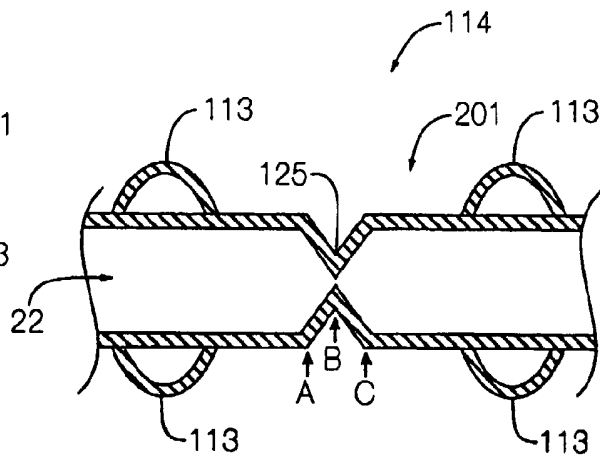

FIG. 7B

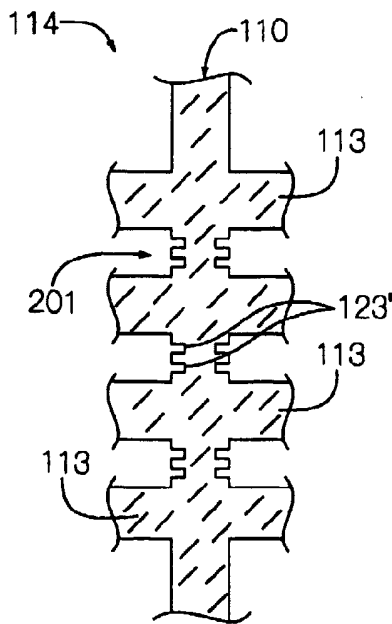

FIG. 7C

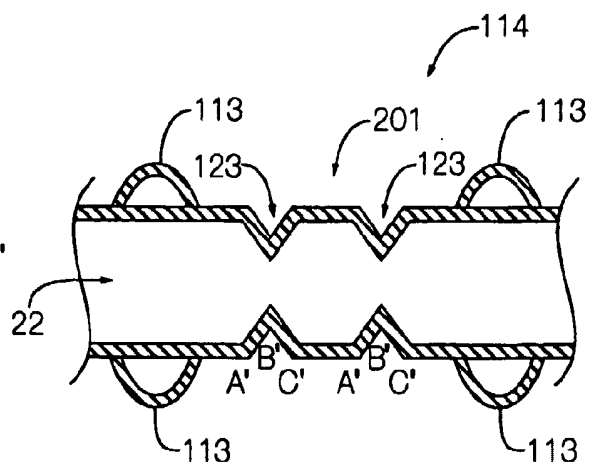

FIG. 7D

14/22

+

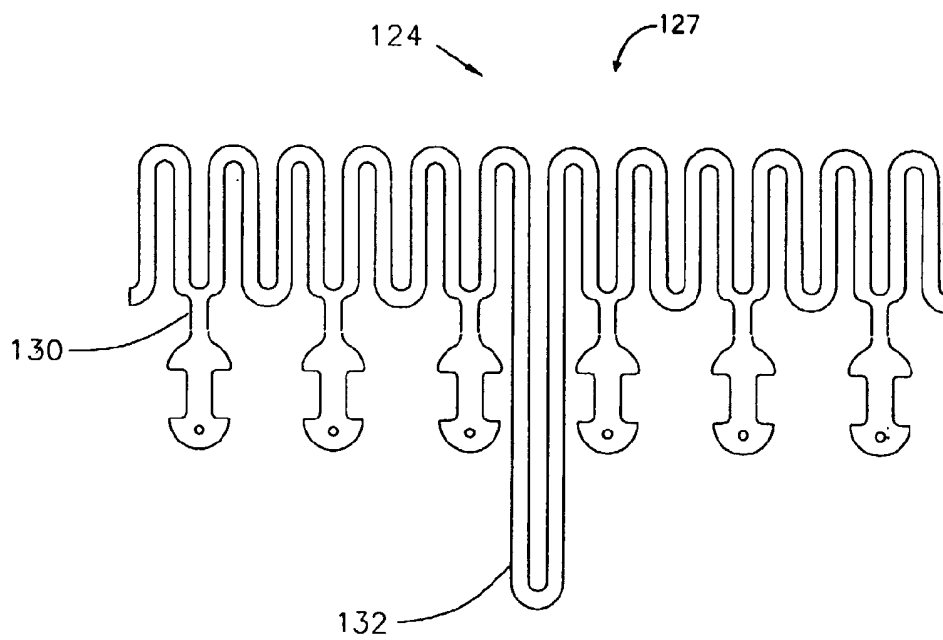

FIG. 8

15/22

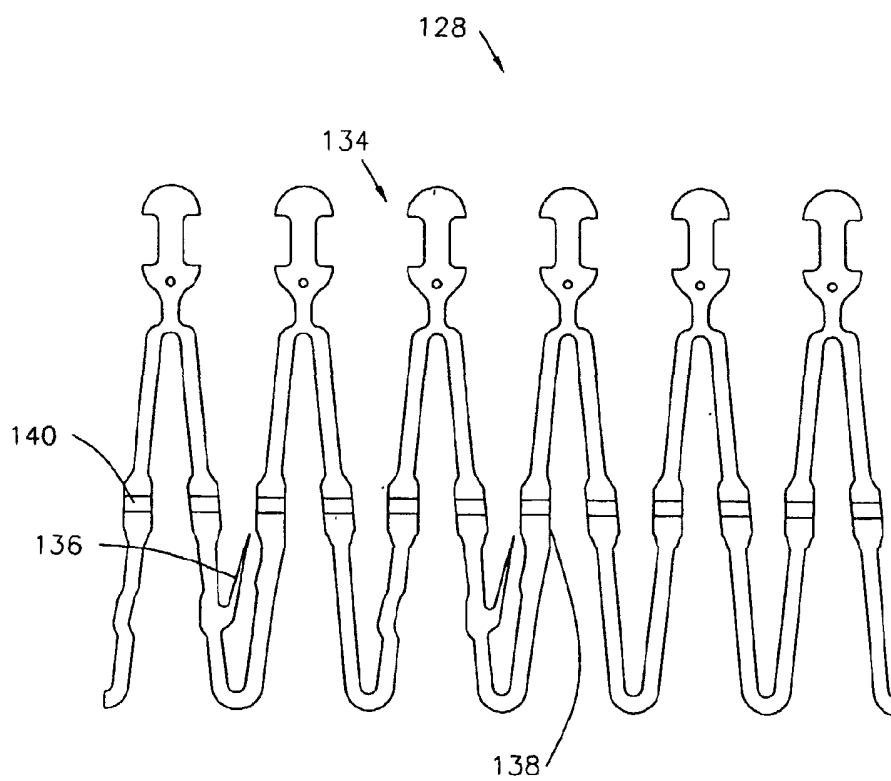

FIG. 9

+

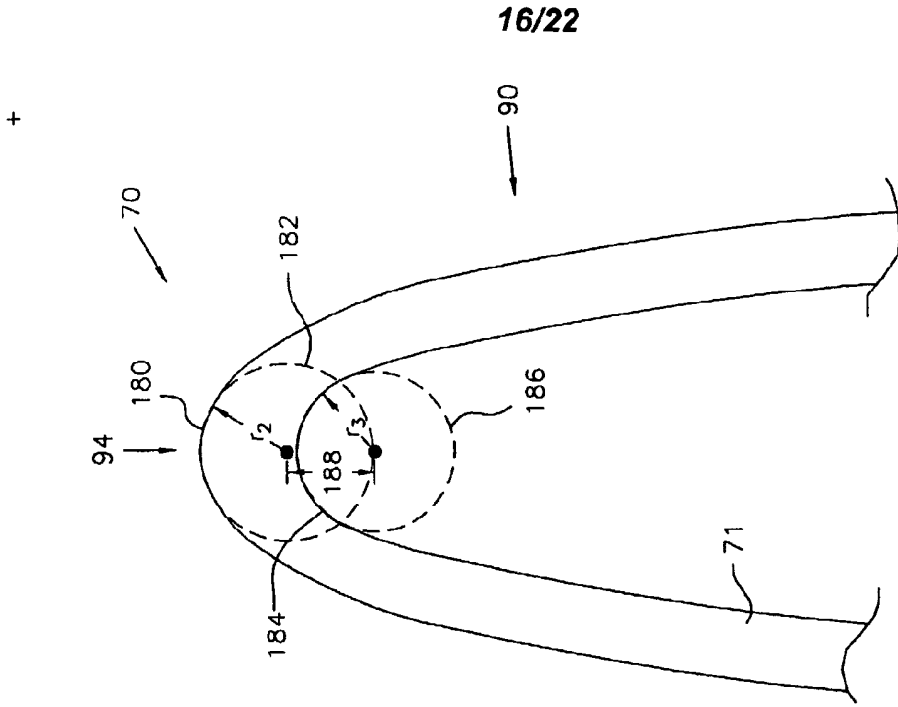

FIG. 10

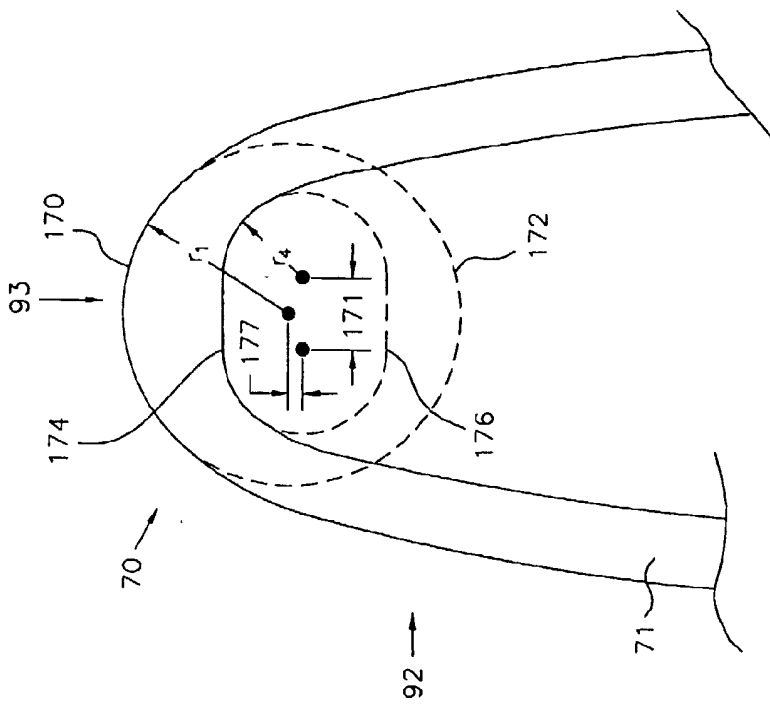

FIG. 11

17/22

+

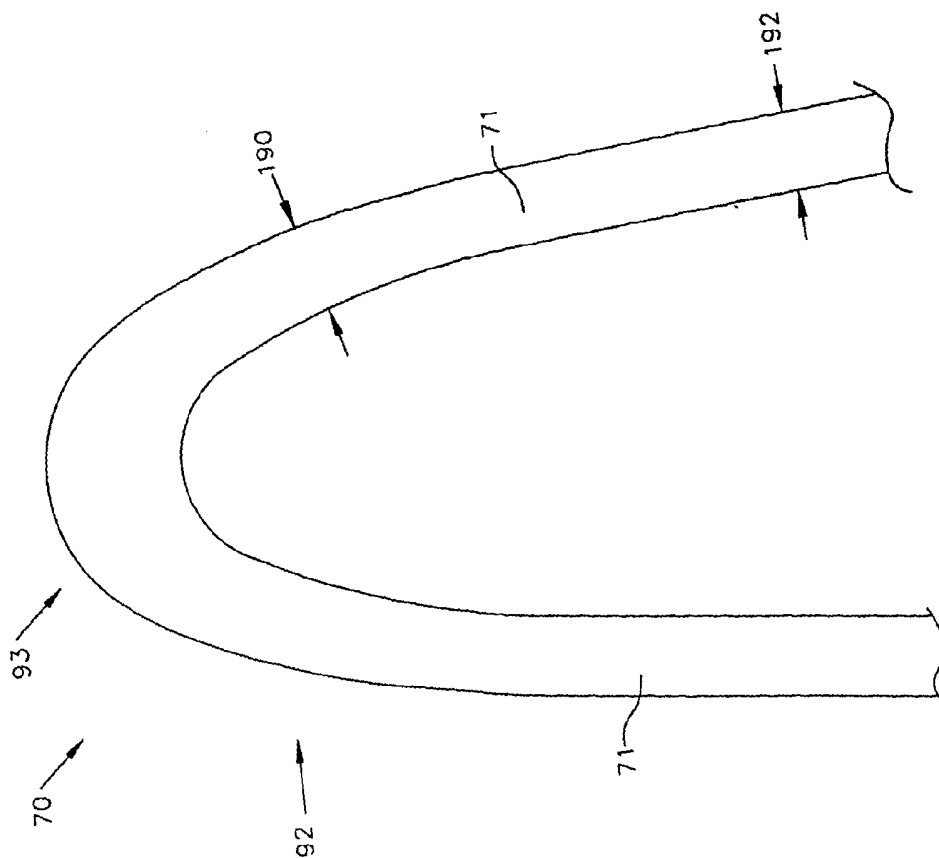

FIG. 12

+

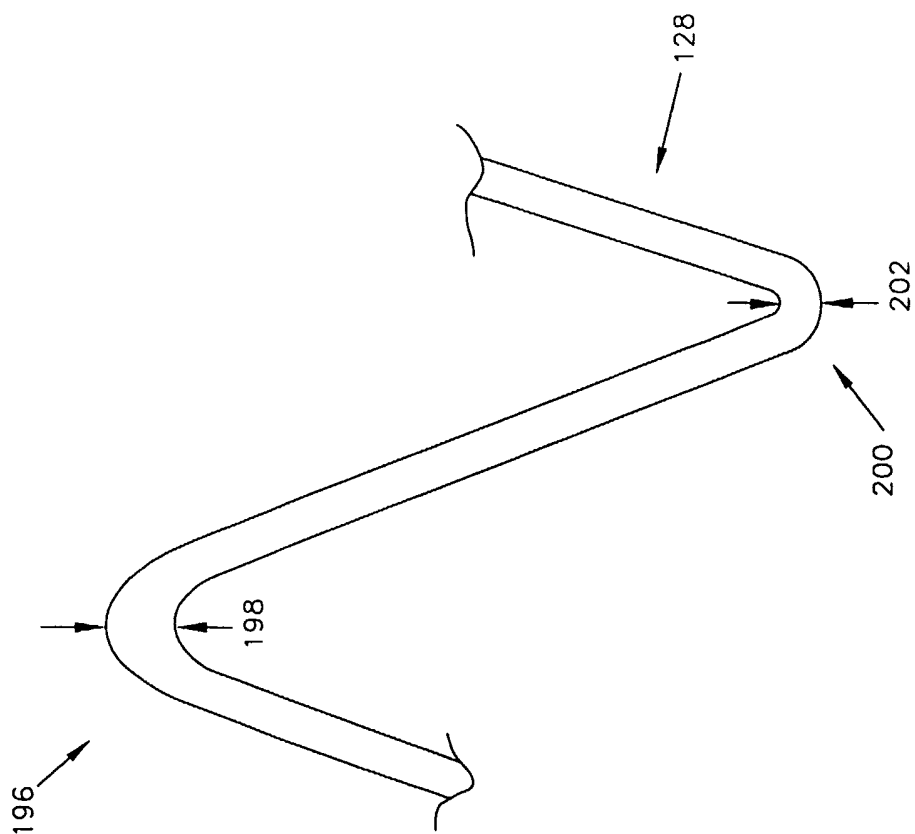

FIG. 13

+

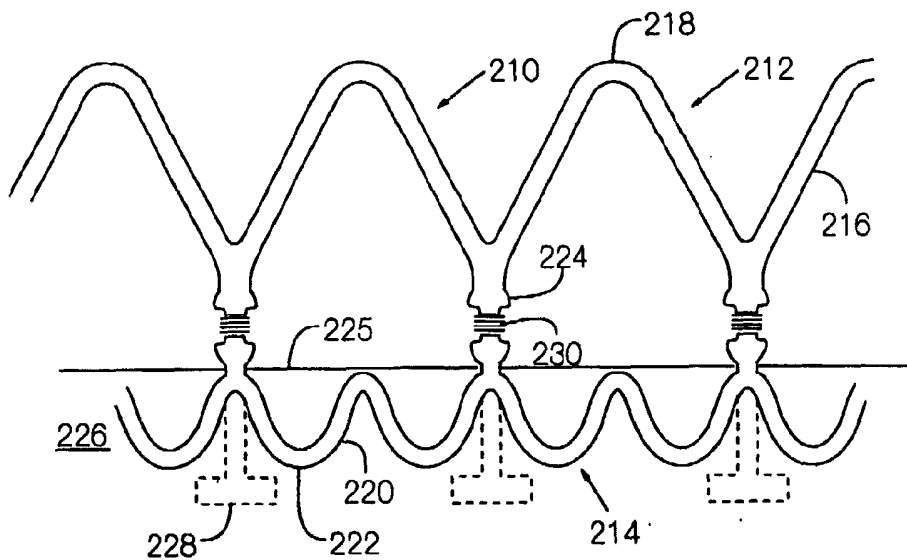

FIG. 14

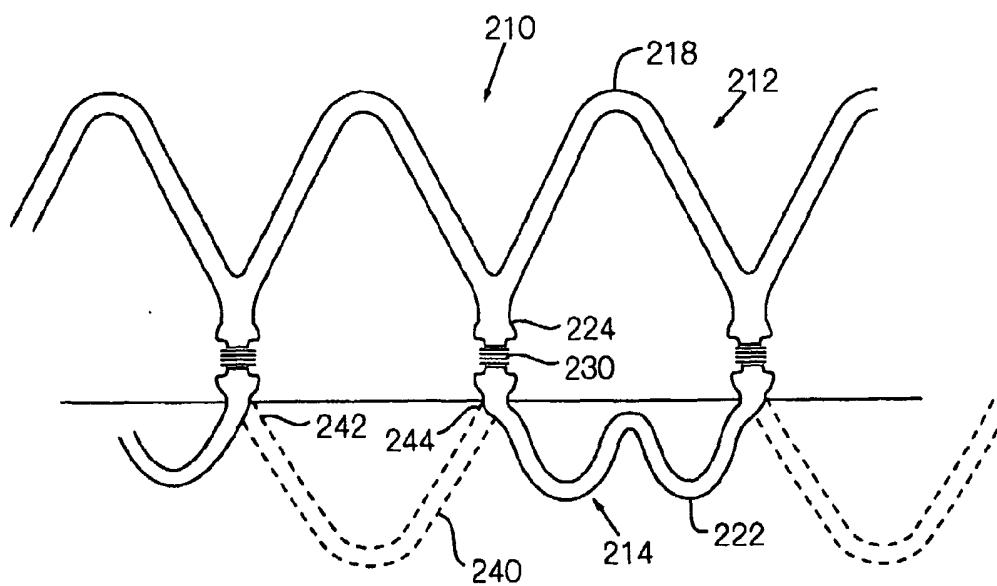

FIG. 15

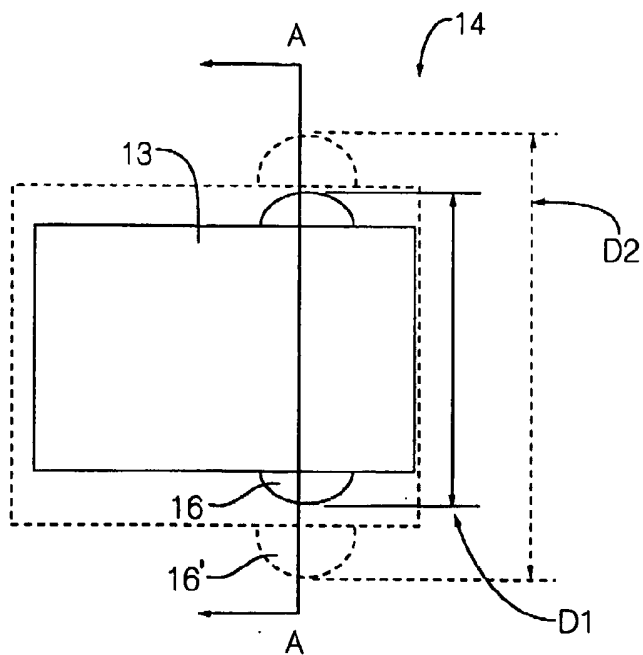
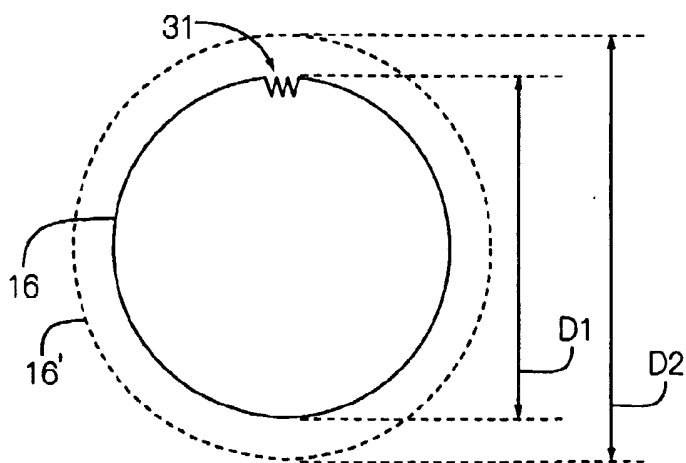

FIG. 16A



Section A-A

FIG. 16B

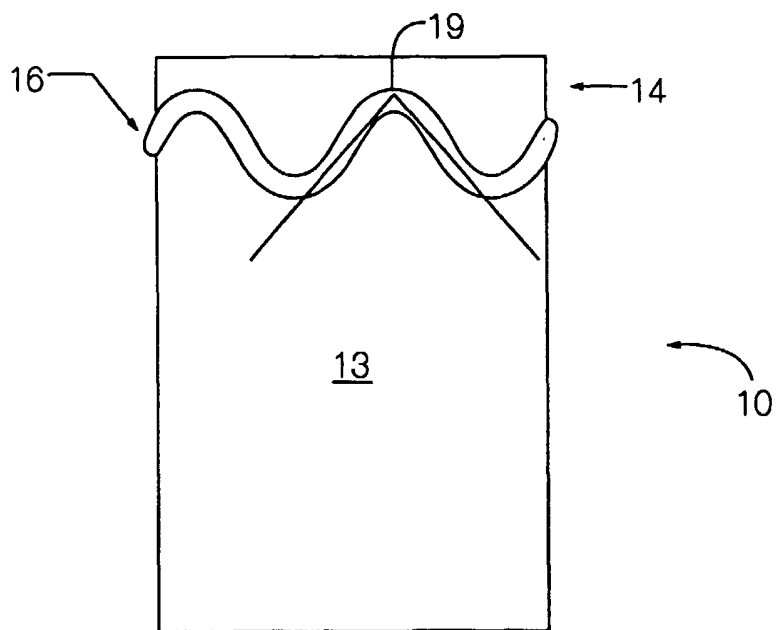

FIG. 16C

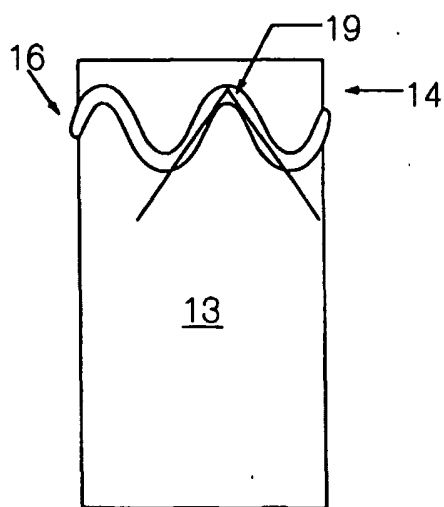

FIG. 16D

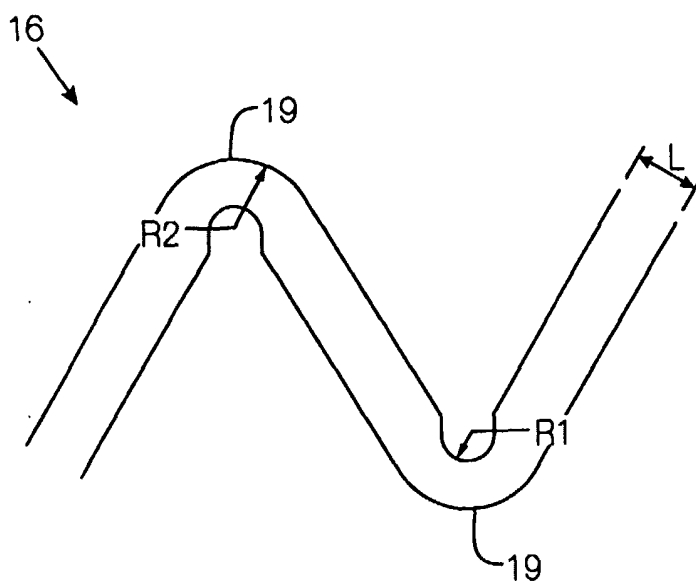

FIG. 16E

INTERNATIONAL SEARCH REPORT

International application No.

PCT/US02/41338

A. CLASSIFICATION OF SUBJECT MATTER

IPC(7) : A61F 2/06
 US CL : 623/1.13

According to International Patent Classification (IPC) or to both national classification and IPC

B. FIELDS SEARCHED

Minimum documentation searched (classification system followed by classification symbols)

U.S. : 623/1.1-1.16, 1.23-1.25, 1.35, 1.36

Documentation searched other than minimum documentation to the extent that such documents are included in the fields searched
 None

Electronic data base consulted during the international search (name of data base and, where practicable, search terms used)
 EAST

C. DOCUMENTS CONSIDERED TO BE RELEVANT

Category *	Citation of document, with indication, where appropriate, of the relevant passages	Relevant to claim No.
X, P	US 6,395,019 B2 (Chobotov) 28 May 2002, see figs. 1-8C.	1-87
Y	US 6,007,575 A (Samuels) 28 December 1999, see figures 1, 5-7.	1-87
Y	US 6,059,823 A (Holman et al.) 9 May 2000, see figures 1-8B.	1-87
Y	US 6,152,956 A (Pierce) 28 November 2000, see figures 3, 5-8.	1-87

Further documents are listed in the continuation of Box C.

See patent family annex.

* Special categories of cited documents:	"T"
"A" document defining the general state of the art which is not considered to be of particular relevance	later document published after the international filing date or priority date and not in conflict with the application but cited to understand the principle or theory underlying the invention
"E" earlier application or patent published on or after the international filing date	"X" document of particular relevance; the claimed invention cannot be considered novel or cannot be considered to involve an inventive step when the document is taken alone
"L" document which may throw doubts on priority claim(s) or which is cited to establish the publication date of another citation or other special reason (as specified)	"Y" document of particular relevance; the claimed invention cannot be considered to involve an inventive step when the document is combined with one or more other such documents, such combination being obvious to a person skilled in the art
"O" document referring to an oral disclosure, use, exhibition or other means	"&" document member of the same patent family
"P" document published prior to the international filing date but later than the priority date claimed	

Date of the actual completion of the international search

24 March 2003 (24.03.2003)

Date of mailing of the international search report

15 MAY 2003

Name and mailing address of the ISA/US
 Commissioner of Patents and Trademarks
 Box PCT
 Washington, D.C. 20231

Facsimile No. (703)305-3230

Authorized officer

(Jackie) Tan-Uyen T. Ho *Diane Smith*
 Telephone No. (703) 308-0858 *for*