

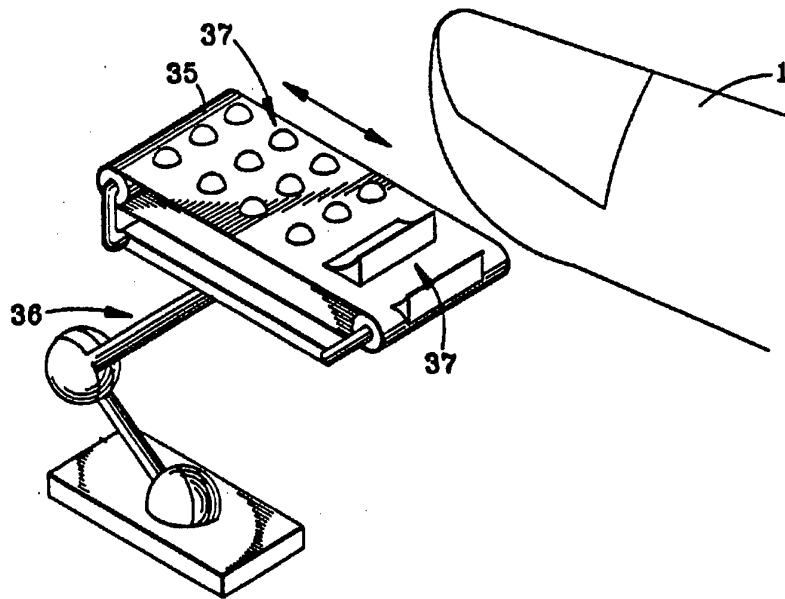

INTERNATIONAL APPLICATION PUBLISHED UNDER THE PATENT COOPERATION TREATY (PCT)

<p>(51) International Patent Classification ⁶ : G06F 3/00</p>	<p>A1</p>	<p>(11) International Publication Number: WO 95/20787 (43) International Publication Date: 3 August 1995 (03.08.95)</p>
<p>(21) International Application Number: PCT/US95/01226 (22) International Filing Date: 27 January 1995 (27.01.95) (30) Priority Data: 08/187,646 27 January 1994 (27.01.94) US (71) Applicant: EXOS, INC. [US/US]; 2A Gill Street, Woburn, MA 01801 (US). (72) Inventors: CHEN, Elaine; 70 Park Street, Somerville, MA 02143 (US). EBERMAN, Brian; 264 Willow Avenue, Somerville, MA 02144 (US). MARCUS, Beth, A.; 78 Woburn Street, Lexington, MA 02173 (US). (74) Agent: PASTERNAK, Sam; Choate, Hall & Stewart, Exchange Place, 53 State Street, Boston, MA 02109 (US).</p>		<p>(81) Designated States: CA, JP, MX, European patent (AT, BE, CH, DE, DK, ES, FR, GB, GR, IE, IT, LU, MC, NL, PT, SE). Published <i>With international search report. Before the expiration of the time limit for amending the claims and to be republished in the event of the receipt of amendments.</i></p>

(54) Title: MULTIMODE FEEDBACK DISPLAY TECHNOLOGY



(57) Abstract

A system for providing haptic information to a human operator. The system utilizes display devices that dynamically convey touch sensations to the human operator, thereby creating various tactile sensations such as texture and slippage. The system can combine multiple display devices as needed in order to create a specified sense.

FOR THE PURPOSES OF INFORMATION ONLY

Codes used to identify States party to the PCT on the front pages of pamphlets publishing international applications under the PCT.

AT	Austria	GB	United Kingdom	MR	Mauritania
AU	Australia	GE	Georgia	MW	Malawi
BB	Barbados	GN	Guinea	NE	Niger
BE	Belgium	GR	Greece	NL	Netherlands
BF	Burkina Faso	HU	Hungary	NO	Norway
BG	Bulgaria	IE	Ireland	NZ	New Zealand
BJ	Benin	IT	Italy	PL	Poland
BR	Brazil	JP	Japan	PT	Portugal
BY	Belarus	KE	Kenya	RO	Romania
CA	Canada	KG	Kyrgyzstan	RU	Russian Federation
CF	Central African Republic	KP	Democratic People's Republic of Korea	SD	Sudan
CG	Congo	KR	Republic of Korea	SE	Sweden
CH	Switzerland	KZ	Kazakhstan	SI	Slovenia
CI	Côte d'Ivoire	LI	Liechtenstein	SK	Slovakia
CM	Cameroon	LK	Sri Lanka	SN	Senegal
CN	China	LU	Luxembourg	TD	Chad
CS	Czechoslovakia	LV	Latvia	TG	Togo
CZ	Czech Republic	MC	Monaco	TJ	Tajikistan
DE	Germany	MD	Republic of Moldova	TT	Trinidad and Tobago
DK	Denmark	MG	Madagascar	UA	Ukraine
ES	Spain	ML	Mali	US	United States of America
FI	Finland	MN	Mongolia	UZ	Uzbekistan
FR	France			VN	Viet Nam
GA	Gabon				

MULTIMODE FEEDBACK DISPLAY TECHNOLOGY

5 The present invention relates generally to a system for providing haptic information to the human body. Haptic or tactual perception, commonly referred to as the "sense of touch", is actually composed of two parts: the cutaneous sense and kinesthesia [Loomis & Lederman, 1986]. The cutaneous sense mediates awareness of stimulation at the skin, while kinesthesia provides information on body parts. Conscious experience of mechanical cutaneous stimulation is known as "tactile perception".

10

Background

The sense of touch, of haptic sense, is complex. Unlike vision, touch involves a direct physical interaction, so that human actions cause and change what is perceived. It is the fundamental role of touch to sense the results of these contact interactions in order to guide manipulation and body motion. The current art only contains devices for presenting a crude tactile image to a location on the body. This type of information represents only a fraction of the total information sensed by the human sense of touch. Many different types of basic information about the contacts are extracted by people through a combination of four different tactile sensory systems, measurement of joint motion, and measurement of joint torques. This basic information can be organized broadly into passively acquired information and actively acquired information. Passively acquired information can be gathered without relative motion between the body and an object and without varying the forces between the body and the object. Actively acquired information requires either relative motion or varying contact forces. A summary of some of the basic types of cues or sensed information is given below.

30

Passively acquired identification cues

Passively acquired identification cues can be obtained by the act of holding an object in the hand. The inventors herein have identified three major cues in this category.

- 5 1. Determining the local contact normal and curvature of the surface at each contact.

Determining the local contact curvature and labeling it as a point, edge, or planar contact is important for grasp acquisition and object identification. Different contact types have different grasp properties which affect stability [Salisbury, 1985]. In addition, the local contact normal and curvature provide a strong pruning heuristic rule for identifying objects and object pose; Grimson, W.E.L., *Object Recognition by Computer: The Role of Geometric Constraint*, MIT Press, Cambridge, MA (1990). Local object curvature can be measured passively by examining the normal contact force distribution.

10

15

2. Determining the surface texture at each contact.

Surface texture affects grasp stability. Rough textures are generally easier to grasp than smooth textures. In addition, surface texture can also be used as a pruning heuristic rule in identifying objects and object pose. Texture cues are produced both from the spatial distribution of the contact force and the dynamic vibration effects produced at the skin during motion.

20

3. Gross object shape.

By using the finger geometry and the location of the contact points in the hand, the shape of the object can be estimated. For example, an initial grasp might be a power grasp in order to get a lot of contact information about an object. Once the object and its shape is identified, a dexterous grasp might be used for manipulation.

25

30

Actively acquired identification cues

With some local active exploration, properties relating the reaction forces to the applied force can also be determined:

5

1. Determining the local stiffness at each contact.

The local surface stiffness can be estimated by applying varying normal forces and measuring the change in contact area. Softer surfaces will produce a larger contact area for a given applied force. This is not a significant cue for manipulation of control surfaces and tools since almost all of the objects involved are rigid.

10

2. Determining local frictional properties.

The local friction along with the local contact type control the local grasp stability. Friction can be measured by applying varying tangential forces and then detecting the onset of slip (slip detection is a separate basic manipulation cue; see next Section). This task also requires the ability to measure tangential forces.

15

3. Overall object stiffness.

By integrating the contact force over an area with the joint torques, and correlating this with joint deflection, the overall object stiffness can be computed.

20

4. Detecting slip.

Detecting the onset of slip between an object and the hand is essential for grasp maintenance. Slip detection is used to determine the necessary grasp forces at each contact during all stages of manipulation.

25

5. Determining object mass (weight), center of mass, and moments of inertia.

By manipulating a grasped object and measuring the resulting joint torques and net contact forces at the hands for different

30

configurations, the weight, center of mass and moments of inertia of

the object can be computed. This information can be used for object identification and pose determination, Siegal, D.M., *Pose Determination of a Grasped Object Using Limited Sensing*, Ph.D. Thesis, Department of Electrical Engineering, MIT, Cambridge, Massachusetts (1991), as well as for computing the necessary torques for throwing or manipulating the object.

6. Estimating directions of contact constraint.

Assembly is the process of bringing a moving part into a constrained relationship with a fixed part. In order to control the assembly process, the directions in which movement is constrained need to be estimated. Contact constraints are estimated using measurements of the reaction forces as a function of position and by measuring the direction of impact forces.

7. Detecting changes in contact constraints.

This is one of the most common tasks during manipulation. The detents in switches, the termination in screws, the impacts from mating two parts are all examples. The onset of the change can be detected by looking for unexplained impact forces and the direction of the impact force.

Review of Haptic Devices

Position and Orientation Devices

Devices and systems are well known for measuring or monitoring one or more characteristics of an anatomical part (see for example U.S. Patent Nos. 4,986,280, 3,258,007 and 3,364,929). A human controlled position sensing device for use in the field of robotics is also well known (see for example, U.S. Patent Nos. 4,328,621, 4,534,694, 4,608,525, and 4,674,048).

Force Devices

Systems are also well known for providing force feedback to human operators. Force-reflective devices exist in a variety of forms, from joysticks to arm and hand controllers. These devices serve as input devices and haptic interfaces for virtual environment manipulation, or teleoperation.

While joysticks are probably the oldest of the haptic interface technologies and were originally conceived to control aircraft, many joysticks currently developed are being used for the control of remote manipulators. AT&T Bell Laboratories has developed a high performance, compact force-feedback joystick. It was intended to support engineering, business, and scientific desktop computing applications. It is 7x4.5x3 inches in size, weighs approx. 2lbs, can apply 75 grams force to the end of the joystick (2 inches long), and can run at over 200 Hz. Its use has been demonstrated for navigating through an electronics CAD database by setting the force to have a step jump at the edge of each trace. It is fast enough to allow the users to feel textures, and provides enough force to give a good range of levels for different conditions.

A significant amount of research has been conducted on robot hands, Salisbury, J.K. and Mason, M.T., *Robot Hands and the Mechanics of Manipulation*, MIT Press, Cambridge, Massachusetts (1985), and force-reflecting controllers, (e.g. Bejezy and Salisbury, 1983, Agronin, 1987) for robot arm manipulation. These controllers can be anthropomorphic but are often tailored to the slave robots and imitate their kinematics. The advantage of controllers that imitate the kinematics of the human hands and arms is that they have the largest user range of motion. However, it is difficult to achieve high quality force feedback with these controllers and minimizing actuator size becomes a major design requirement. The Stanford/JPL 6 DOF hand controller is an example of a compact non-anthropomorphic force reflecting arm master. Sargent Industries/CRL manufactures a variety of master-slave manipulators for use in hazardous

environments. Though their systems do provide force feedback, they are large, non-anthropomorphic, and are not meant to be portable. Similarly, Schilling Development, Inc. produces the TITAN 7F, and the GAMMA 7F, both of which are 6-4 Titanium constructed servo, hydraulic master/slave systems. The GAMMA 7F allows operation in radioactive environments. However, the force-feedback versions are still under development, and the master controllers are only semi-anthropomorphic.

One complete anthropomorphic system (Jacobsen 1989) uses high performance hydraulic actuators to provide force-reflection for 7 DOF up to and including the wrist, with more DOF's in the gripper (Sarcos, 1991). The device has a large range of force exertion at a relatively high bandwidth. However, it is bulky and also very expensive. Two other anthropomorphic teleoperation systems include the Force-Reflecting Hand Controller (FRHC) (McAfee et al.), and the Odetics exoskeleton (Burke, 1991). Both use steel cables to reflect forces and moments and remotely locate the motors. The FRHC provides motion in 6 DOF while the Odetics exoskeleton uses 7 DOF to represent the human arm. However, these systems are still not portable force-feedback devices. Iwata (Iwata 1990) describes a system for the thumb, two fingers and the palm. The palm is actuated by a six degree-of-freedom parallel stage driven by electric motors. Each of the two fingers and thumb has single DOF motion and is also driven by electric motors. This system can transmit large forces to the hand and fingers, but is limited to pinch type grasps because of the single DOF plates for the fingers.

Burdea, Zhuang, and Roskos (1991) describe a system based on pneumatic cylinders and the VPL dataglove. This system generates forces using pneumatic cylinders placed between the inside of the palm and the fingertips. The system is compact and lightweight, but at present can only simulate grasp forces between the palm and the fingertips. Contact of the fingers with objects supported externally cannot be simulated. While many

forms of force-feedback devices have been developed, not many complete anthropomorphic systems exist. Of the anthropomorphic arm systems, the main disadvantage is their bulkiness and non-portability.

5 Tactile Devices

Tactile devices are also well known and fall into five basic categories. Tactile displays have been the subject of much research activity in the past thirty years. While neuroscientists studied the physiological roots of human tactile perception, engineers were interested in tactile display devices that substituted or augmented other senses such as sight and hearing. Tactile displays also demonstrated their usefulness in VR simulations and telerobotic operations by EXOS TouchMaster which utilized buzzers to display contact information of objects. To design a high performance force reflective exoskeleton master, tactile displays might provide the teleoperator with additional information such as contact locations that could not be adequately displayed by force alone. Or tactile displays might simplify the requirement on force reflection. It was conceivable that a combination of tactile display and force reflection would be haptically more effective, technically less challenging and economically more feasible than force reflection alone.

20 The following paragraphs present an overview of tactile display technologies and their applications developed in the past thirty years.

Air or water jet displays

Not all tactile displays make mechanical contact with the skin. Air or water jet displays are attractive because they eliminate the need for moving mechanical parts and because they exhibit a consistent frequency response. Air jet arrays were extensively tested by Bliss, J.C., Crane, H.D. and Link, S.W., *Effect of Display Movement on Tactile Pattern Perception*, Perception and Psychophysics, 1:195-202, (1966), and Bliss, J.C., Crane, H.D., Mansfield, P.K. and Townsend, J.T., *Information Available in Brief Tactile*

Presentations, Perception and Psychophysics, 1:273-283 (1966) in different configurations with applications in vision substitution Bliss, J.C., Crane, H.D. and Link, S.W., *Effect of Display Movement on Tactile Pattern Perception*, Perception and Psychophysics, 1:195-202, (1966), Rogers, 5 C.H., *Choice of Stimulator Frequency for Tactile Arrays*, IEEE Transactions on Man-Machine Systems (special issue), MMS-11(1) (March, 1970) and as a user interface in tracking experiments, Hill, J.W., *A Describing Function Analysis of Tracking Performance Using Two Tactile Displays*, IEEE Transactions on Man-Machine Systems (special issue), MMS-11(1) (March, 10 1970). Steerable air and water jets were also investigated as a "substitute cathode ray tube", tracing cursive letters or figures or re-creating a visual image in a raster scanned format on the skin, Bliss, J.C., *Tactual Perception: Experiments and Models*, Stanford Research Institute, Menlo Park, California, Final Report, Technical Report AFAL-TR-66-242, 15 Contracts AF33(615)-1099 and NAS2-2752, SRI Projects 4719 and 5438 (July, 1966), and Collins, C.C. and Madey, J.M.J., *Tactile Sensory Replacement*, Proceedings of the San Diego Biomedical Symposium, pp. 15-26 (1974).

20 Air or water bladder displays

Air or water bladder displays are used to apply a continuous pressure on an area of skin. An example is the TELETACTION device (Air Muscle Ltd), which consists of an elastic lycra glove lined with approximately twenty air pockets fed by microcapillary tubes, Stone, R.J., *Advanced 25 Human-System Interfaces for Telerobotics Using Virtual Reality and Telepresence Technologies*, Proceedings of the International Conference on Advanced Robotics, Pisa, Italy, 168-173 (June, 1991). This glove may be worn inside measurement devices such as the Mattel Power Glove or the EXOS Dextrous HandMaster (DHM) when interacting with a virtual

environment. Air pockets generally suffer from extremely low bandwidth (order of 1Hz) because of the elasticity of the bladder material.

Mechanical tactor elements or arrays that impact or indent the skin

5 This group of displays include most of the vibrotactile devices described in the literature in addition to a few displays operated at a very low frequency that would not normally be considered vibrotactile (such as the tactile interface for IBM graphics described by Frisken-Gibson, S.F., Bach-y-Rita, P., Tompkins, W.J. & Webster, J.G., *A 64 Solenoid, Four*
10 *Level Fingertip Search Display for the Blind*, IEEE Transactions on Biomedical Engineering, BME-34:963-965 (1987).

 While there are a few single-element display devices (see Goldstein, M.H. and Proctor, A., *Tactile Aids for Profoundly Deaf Children*, Journal of the Acoustical Society of America, 77:258-265 (1985), Terry, J.A. and
15 Hsiao, H., *Tactile Feedback in a Computer Mouse*, Proceedings of the Fourteenth Annual Northeast Bioengineering Conference, p. 146-149 (March, 1988)), the vast majority of mechanical tactile displays involve tactor arrays. The number of elements in these arrays run from two (such as the stump-mounted upper-limb prosthesis elbow angle display developed
20 by Mann, R.W. and Reimers, S.D., *Kinesthetic Sensing for the EMG Controlled "Boston Arm"*, IEEE Transactions on Man-Machine Systems (special issue), MMS-11:110-115 (1970) to 400 (such as the 20x20 back mounted array of solenoid activated tactors used by White, B.W., *Perceptual Findings with the Vision-Substitution System*, IEEE Transactions
25 on Man-Machine Systems (special issue), MMS-11:54-58 (1970), and Collins, C.C., *Tactile Television - Mechanical and Electrical Image Projection*, IEEE Transactions of Man-Machine Systems, MMS-11, 58-65 (1970).

 Almost all of the devices in this group involve indenting or impacting
30 the skin perpendicular to the skin surface. Two methods of actuation

dominate these displays: solenoid activated pins and cantilevered piezoelectric bimorph reeds with a pin mounted to the tip. The OPTACON is an extremely well known piezoelectric bimorph activated vibrator array developed by Bliss et al (1970). It is a small 1.1x2.7cm display with a

5 matrix of 6x24 tactors, and can be operated from 12.5 Hz to 250Hz. It was originally designed to serve as a reading aid for the blind in conjunction with an optic probe which digitizes the information in printed text, but due to its versatile design it was used extensively as a research tool by a variety of researchers (such as Wiker, S.F., Vanderheiden, G., Lee, S. and Arndt, S.,

10 *Development of Tactile Mice for Blind Access to Computers, Importance of Stimulation Locus, Object Size, and Vibrotactile Display Resolution*, Proceedings of the Human Factors Society , 1: 708-712 (1991). The OPTACON is now commercially available from TeleSensory Systems. Another method of actuation that has great potential is the use of shape

15 memory alloys (SMA). As a current is passed through the alloy, it changes shape and deflects a spring that holds a tactor pin in place; Johnson, A.D., *Shape Memory Alloy Tactical Feedback Actuator*, No. AAMRL-TR-90-039 (available through NTIS), TiNi Alloy Co., Inc., Oakland, California, under sponsorship of Harry G. Armstrong Aerospace Medical Research

20 Laboratory, Wright-Patterson AFB, Ohio (August, 1990), and McCarty, L.H., *Special Alloy is Key to Braille Computer Display*, Design News (Boston), 46(3):158-159, (February 12, 1990). TACTOOLS is a commercial tactile feedback product available from Ztensory Inc. for use in teleoperation and virtual reality (VR) applications. The same product is also

25 available from Mondo Tronics.

Voice coil displays

These displays generate vibratory sensations by mounting a voice coil against the skin. Examples are found in Patrick, N.J.M., Sheridan, T.B.,

30 Massimino, M.J., Marcus, B.M., *Design and Testing of a Non-Reactive,*

Fingertip Tactile Display for Interaction with Remote Environments, SPIE Vol. 1387 Cooperative Intelligent Robotics in Space, 215-222 (1990), and Patterson, P.E. and Katz, J.A., *Design and Evaluation of a Sensory Feedback System that Provides Grasping Pressure in a Myoelectric Hand*, 5 Journal of Rehabilitation Research and Development, **29**(1):1-8, (Winter, 1992). The *TouchMaster* is a voice-coil based tactile feedback device manufactured by EXOS.

Electrotactile displays

10 Electrotactile displays elicit touch sensations by indiscriminately stimulating all the touch and pain sensors in the skin with a current passing through the skin. These devices usually involve a remote stimulator (which supplies the power and generates the stimulation waveform) and a number of electrodes mounted on the skin using a sticky dielectric. Each electrode pair 15 constitutes a stimulation site. While some systems involve single or a small number of isolated electrode pairs (such as the functional electrical stimulation feedback system developed by Rutherford, K.M., Riso, R., and Neuman, M.R., *A Finger Mounted Force Sensor for Use with an FNS Hand Grasp System*, Proceedings of the IEEE 9th Annual Conference of the 20 Engineering in Medicine and Biology Society, pp. 1757-1758, arrays of electrodes were also popular, with number of elements running up to 1024 in one instance, Collins, C.C. and Madey, J.M.J., *Tactile Sensory Replacement*, Proceedings of the San Diego Biomedical Symposium, pp. 15-26 (1974).

25 Large arrays with electrotactile displays are achieved by using small, closely spaced concentric electrode pairs in a grid, Collins, C.C. and Madey, J.M.J., *Tactile Sensory Replacement*, Proceedings of the San Diego Biomedical Symposium, pp. 15-26 (1974). When the stimulation sites are few and sparsely distributed, a large common anode could be placed at a 30 distance from the stimulation sites. The *TICKLETALKER*, Alcantara, J.I,

Blarney, P.J., and Clark, G.M., *Tactile-Auditory Speech Perception by Unimodally and Bimodally Trained Normal Hearing Subjects*, Journal of the American Academy of Audiology, 4(2):98-108, (March, 1993) is one such device, in which 8 cathodes are mounted on four metal rings worn on each
5 of the four fingers, and a large anode is mounted on the wrist.

Current tactile feedback devices present a flat contact image using either arrays of tactors or raster scan techniques. This type of display can only be used for very local shape display or textures, and is limited to a flat type of display. Current force display devices can improve this situation
10 when used in combination with tactile feedback, however the force displays have often geometrically limited the applicability of tactile displays. The concept of multimode feedback, that is the combination of one or more haptic modes in a single system, was developed specifically to overcome the limitations of the prior art.

15

Summary of the Invention

It is therefore a general object of the current invention to provide a set of technologies and a method of providing touch or haptic information.

It is a more specific object of the current invention to provide a set of
20 technologies and a method which can be used to present critical information either separately or in combination.

Another specific object of the current invention to provide a set of technologies and a method which can be used to present haptic cues either separately or in combination.

25 And another specific object of the current invention is to provide a strategy for coordinating multiple feedback modes such as force and tactile.

Yet another specific object of the present invention is to provide a haptic display which provides a continuous range of forces to the skin.

Yet another specific object of the present invention is to provide a haptic display which provides a time varying texture through relative tangential motion between the device and finger.

5 These and other objects of the present invention are achieved by a system for displaying multimode feedback to an operator. The system comprises:

- A device for displaying tactile information to a body part;
- Means for tracking the position and orientation of the body part;
- Means for applying forces to the body part;
- 10 Means for implementing a multidimensional control strategy; and
- Sensors for sensing body forces.

Other objectives of the invention will in part be obvious and will in part appear hereinafter. The invention accordingly comprises an apparatus
15 possessing the construction, combination of elements, and arrangements of parts which are exemplified in the following disclosure, and the scope of the application of which will be indicated in the claims.

Brief Description of the Drawing

20 Figure 1a and Figure 1b are block diagrams of the preferred computerized system for obtaining and storing sensory information, controlling the displays, and communicating with other computers involved in the application;

Figure 2 is an overview of the preferred haptic display unit;
25 Figure 3 is a detail of the slip display element;
Figure 4 is a concept sketch of an activated trackball based display;
Figure 5 is a concept sketch of a two-degree-of-freedom roller display;

Figure 6 is a concept sketch of an endless belt with various surface
30 features mounted on a six degree-of-freedom mini-manipulator display;

Figure 7 is a concept sketch of a display consisting of several actuated thimble rings with internal features;

Figure 8 is a concept sketch of a rotating solid cylinder with different surface features at different angular positions;

5 Figure 9 is a concept sketch of a display consisting of a rotating, flat slotted disk with an articulated linkage;

Figure 10 is a concept sketch of a display with a piezoelectric bimorph actuator element mounted on top of a linear piezoelectric actuator element;

10 Figure 11 is a concept sketch of a display in which steel pins are deflected by a varying magnetic field set up by an electromagnet array;

Figure 12 is a block diagram and flow chart of the local processor as it interacts with the world modeling computer.

The same numeral are used throughout the drawings to designate the
15 same or similar parts.

Description of the Preferred Embodiment

The present invention generally relates to a system and method for providing touch feedback to the human operator and is adapted to have at
20 least two applications. The system is useful in the control of computer generated or virtual environments and of real or robotic environments. (See Figures 1a and 1b.)

In the preferred embodiment as shown in Figures 2 and 3, four sense and display elements were used; slip on the finger tips, force feedback to the
25 index finger and thumb, variable frequency and amplitude vibrotactile displays to the fingertips (the EXOS TouchMaster) and vertical resistance. In addition the device provides position and orientation of each of the system elements. The reference numerals are defined as follows:

1. Index finger
- 30 2. Thumb

3. Tactile display (including slip and vibrotactile elements)
4. Slip display motor
5. Vibrotactile display
6. Modified two-degree-of-freedom SAFiRE providing force feedback to
5 the index finger
7. Proximal linkage of the modified two-degree-of-freedom SAFiRE.
8. Distal linkage of the modified two-degree-of-freedom SAFiRE.
9. Cable conduits on the modified two-degree-of-freedom SAFiRE.
10. Motor package for the index finger and thumb force reflection
10 mechanisms
11. Thumb force reflection device
12. Strap mounted bracket for haptic feedback device
13. Mounting bracket for haptic feedback device
14. Proximal passive pivot
- 15 15. Horizontally mounted linkage
16. Distal passive pivot
17. High resolution encoder
18. Front linear way
19. Front sliders
- 20 20. Front slider mounting plate
21. Second vertical cable
22. Set of idler pulleys
23. Motor actuating vertical degree-of-freedom through a cable system
mounted on the rear slider
- 25 24. Vertical support structure
25. Heavy base
26. Textured delrin surface
27. Miniature bearing
28. Set screw
- 30 29. Mounting bracket for the slip and vibrotactile display elements

- 30. Finger strap
- 31. Activated trackball
- 32. Pinch rollers for driving the trackball
- 33. Flat surface on trackball
- 5 34. Two-degree-of-freedom roller
- 35. Endless belt
- 36. Six-degree-of-freedom roller
- 37. Surface features on the belt
- 38. Actuated thimble
- 10 39. Independently actuated thimble rings
- 40. Internal features inside thimble rings
- 41. Indexing cylinder
- 42. Surface features at different angular positions on the indexing cylinder
- 43. Slotted flat disk
- 15 44. Actuated, articulated linkage
- 45. Piezoelectric bimorph actuator element
- 46. Linear piezoelectric actuator element
- 47. Steel pins
- 48. Array of electromagnets

20 In this embodiment a simple slip display 3 was developed. This slip display 3 consists of a delrin cylinder 26 with a textured surface, directly mounted on the shaft of a miniature gear motor 4. The cylinder 26 is supported on the other side with a miniature bearing 27. The motor is held by a set screw 28 in the mounting bracket.

25 The motor 4 was powered by a linear motor amplifier (not shown) and controlled by an MC-series Motion Controller board (Motion Engineering Inc., CA.)(not shown). The major specifications for the slip display and the associated experimental setup are: the slip display must be able to provide endless slip; it must be able to overcome the friction
30 imposed by the normal contact force (up to 2 lb) between the fingertip and

the force display; the maximum attainable speed of slip should be around 1 in/sec; the weight of the slip display should be less than 0.5 lb.

5 A voice coil vibrotactile display 5 which is comprised of a small magnet mounted in a shaped plastic housing. When excited by the control electronics it produces a variable frequency variable amplitude vibration to the housing. In the preferred embodiment this display 5 was attached to the mounting block of the slip display 3, and thus provides a vibratory stimulus to the fingertip.

10 The slip display 3 was attached to the tip of each of the index finger force feedback apparatus 6 and the thumb force feedback apparatus 11. Force reflection to the index finger 1 is provided by a modified two-degree-of-freedom SAFiRE (U.S.S.N. 07/961,259, filed October 15, 1992, entitled "Sensing and Force reflecting Exoskeleton") prototype, which consists of two cable-driven linkages, with the two motors 10 mounted on the forearm. 15 The axes of rotation of the linkages are co-located with the PIP and MCP joints of the index finger. Force reflection to the thumb is provided by a one-degree-of-freedom device, also driven by cables from a remotized motor mounted on the forearm.

20 The vertical resistance and position and orientation in space is provided by a boom. The vertical force reflection axis provided up to 2 lbs of virtual weight at the hand. It also supported the weight of the SAFiRE through counterbalancing. The stiffness of the vertical boom up to the SAFiRE attachment bracket exceeded 140 lb/in, the minimum stiffness required for a cantilevered beam to feel rigid to a human operator, Tan, 25 B.T., *Sensor Application to Space-Suit Glove*, Tactile Sensors for Robotics and Medicine, J.G. Webster (Ed.), John Wiley and Sons, New York, 331-340 (1988). The resolution of the vertical and horizontal position sensors for the hand and index finger was 0.005 inch. Two linear ways were mounted on opposite sides of the vertical support structure, which was 30 rigidly attached to a heavy base.

The drive mechanism for the vertical degree-of-freedom was located on the back of the support structure. The motor providing vertical force reflection was horizontally mounted on the slider riding in the rear linear way. A threaded capstan was directly mounted on the shaft of the motor 23.

5 A 7x7, 0.032 inch diameter steel cable was wound 3-4 turns around the capstan. One end of the cable was terminated at the bottom of the vertical support structure. The other end was terminated on a cable tensioner at the top of the structure. As the motor rotated, the cable hoisted the slider up and down the rear linear way.

10 The rear slider was connected through a second cable and a set of pulleys to a plate mounted on two sliders riding in a second linear way 18, mounted on the front side of the vertical support structure. Using two sliders instead of one greatly improved the twisting and bending load capacity of the front linear way. The two sliders were mounted on the plate

15 through two pivots to minimize bending moments applied to the front linear way.

Vertical forces were transmitted to the SAFiRE by a horizontally mounted linkage. The linkage consisted of a distal block attached to the front slider plate 20, proximal block, and a 12 inch long rod. The distal

20 block housed the bearings and the encoder for the first passive pivot, also called the distal pivot. One end of the rod was pivoted about this block so that the linkage rotated freely in the horizontal plane. The other end of the rod was pivoted about a second bearing/encoder housing, also called the proximal pivot 14. The proximal mounting block was attached to the

25 SAFiRE base with a rigid bracket. The length of this bracket was designed to position the hand so that the proximal pivot was between the tip of the index finger and the thumb.

The motor for vertical force reflection was selected based on the power requirements. We would like the motor to produce a force of 2 lbs at

30 the hand. We also estimated that the hand could move at a maximum

vertical speed of 8 in per sec. We selected 90W motor without a gearhead to provide a smooth operation with minimal friction. The HEHD is designed to produce a force of 2 lb. at the fingertip. The tactile display must produce a force that exceeds the corresponding frictional force, if the frictional coefficient between the finger and the display is estimated at 0.5, the tactile display must be able to produce 1 lb. of force. If the display moved past the finger at 1 in/s, the required power would be around 0.112W. A motor producing 0.25-0.5 W would therefore be a suitable actuator for this display. The MicroMo Series 1016 motor fits these requirements; it is 0.384 inch in diameter, 0.63 inch long and weighs 0.23 oz. This is mounted in the space beyond the fingertip.

This touch display hardware is interfaced to the world model, in this case implemented on a graphics rendering PC, through a local processor, in this case a VME card cage which houses a TIC30 DSP board, I/O boards, and a BiT3 VME-ISA bus adapter.

The preferred embodiment is not the only viable implementation of the multimode feedback. Any one element, such as the slip display, when combined with position or orientation sensing becomes a multimode display and thus must use the strategy for coordination, in a simplified form. Each sense and display unit has the ability to provide haptic cues to the operator as do the following alternate embodiments. The alternate embodiments can be roughly classified into trackball ideas, roller and belt ideas, indexing ring/cylinder ideas, piezoelectrically actuated devices, magnetically actuated devices and other miscellaneous concepts.

25

Trackballs

The trackball (Figure 4) concepts involve frictionally driven balls. The trackball can have two degrees-of-freedom and can produce lateral skin stretch as well as a sense of slip. However, it can not represent the nature of contact geometry.

30

A variation on this theme involves cutting a flat surface on the ball. This would produce a plane as well as an edge on the ball depending on how it is oriented with respect to the fingertip.

5 Roller and belts

A single roller can represent endless slip in two directions. If the roller is rotated about the center of the fingertip, slip in any direction may be simulated. If it is pressed hard against the fingertip, lateral skin stretch may be induced (see Figure 5). A row of such rollers can represent slip as
10 well as a rough simulation of a flat surface (as long as the rollers are small and closely spaced).

An endless belt 35 (Figure 6) may provide a better representation of a flat surface. If the endless belt can be rotated on its side, the edge of the belt can represent an edge. If the endless belt is mounted on a 6 degree-of-
15 freedom miniature manipulator 36, it can represent slip and lateral skin stretch in any direction. Surface features may be built into the belt so that different textures are represented by different sections of the belt.

Indexing ring/cylinder

20 A thimble 38 (Figure 7) made of several rings 39 with internal ridges may be built. By lining up the ridges on different rings, edges with different orientations may be created under the fingertip. Rotating each ring will also present a sense of slip in a direction normal to the longitudinal axis of the finger.

25 Alternatively, a solid cylinder 41 (Figure 8) with different surface features at different angular positions may be built. By rotating the cylinder, different textures may be presented to the fingertip.

A third variant involves a flat disk 43 (Figure 9) with a slot down the middle of the disk. A miniature articulated linkage 44 may be raised from
30 the slot to create a corner. When the linkage is retracted, a flat circular

surface will be presented. Spinning the disk will create a sense of slip. Adding a rotational degree of freedom will allow the disk to be tilted with respect to the fingertip.

5 Piezoelectrically activated devices

A piezoelectrically micromotor may be used to generate rotation in a small package. Alternatively, a deflecting piezoelectric actuator 45 may be mounted on top of a linear piezoelectric actuator 46 to produce a tiny manipulator that can push on the fingertip as well as drag it sideways for
10 normal and lateral force representation (see Figure 10).

Magnetically activated devices

Using a complex magnetic field, ferrite dust may be made to form different shapes. Alternatively, by modulating the polarity and strength of
15 an array of electromagnets 48, tiny steel pins 47 may be deflected to generate different shapes at the fingertip (see Figure 11).

Others

Other ideas include using a thermoelectric cooling chip mounted
20 against the finger to act as a heat sink. Since most metals are cold to the touch, this artificially induced heat loss may generate an illusion of being in contact with metal.

Certain changes may be made in the above apparatus without departing from the scope of the invention involved herein. It is intended
25 that all matter contained in the above description or shown in the accompanying drawings shall be interpreted in an illustrative and not in a limiting sense.

CLAIMS

1. Apparatus for displaying tactile information to a body part comprising:
- 5 means for tracking the position and orientation of the body part;
 means for applying forces to the body part;
 means for implementing a multidimensional control strategy; and
 sensors for sensing body forces.
- 10 2. The apparatus of claim 1 wherein the means for implementing the control strategy comprises;
- a mounting bracket;
- a rotatable textured cylinder mounted in the bracket; and
- 15 a motor adapted to rotate the cylinder according to the control strategy.
3. The apparatus of claim 2 further including a second haptic display.

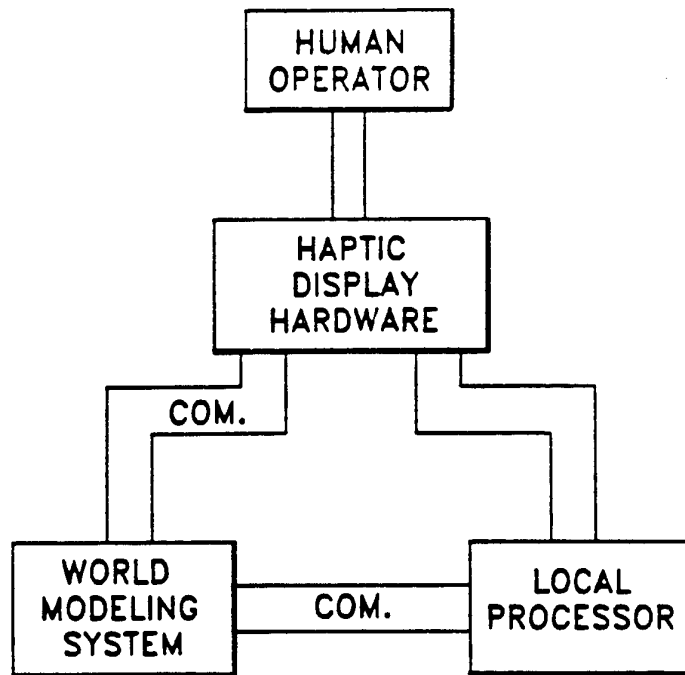

FIG. 1A

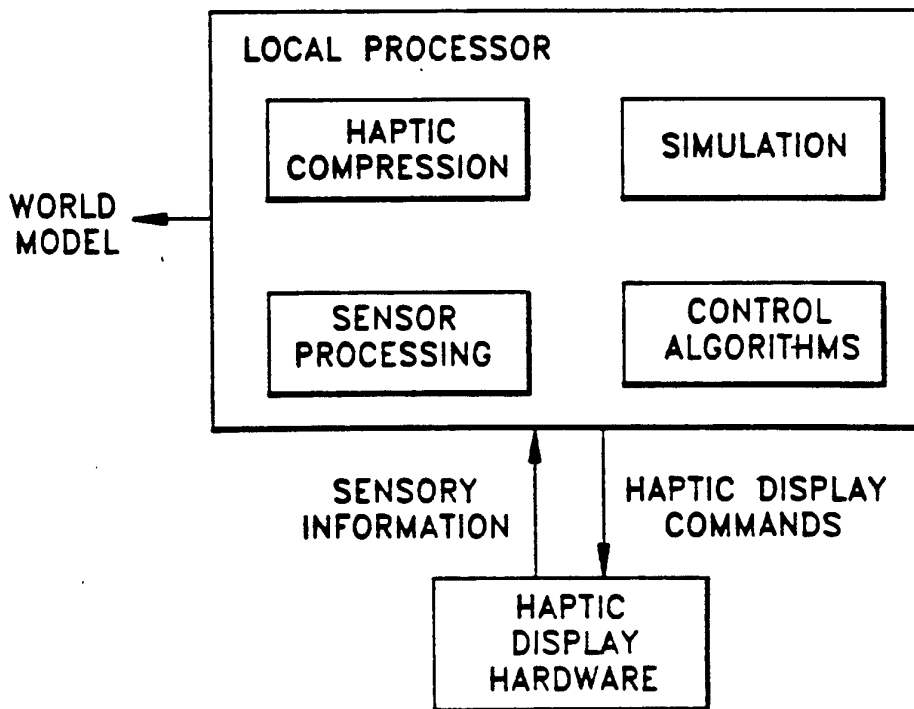

FIG. 1B

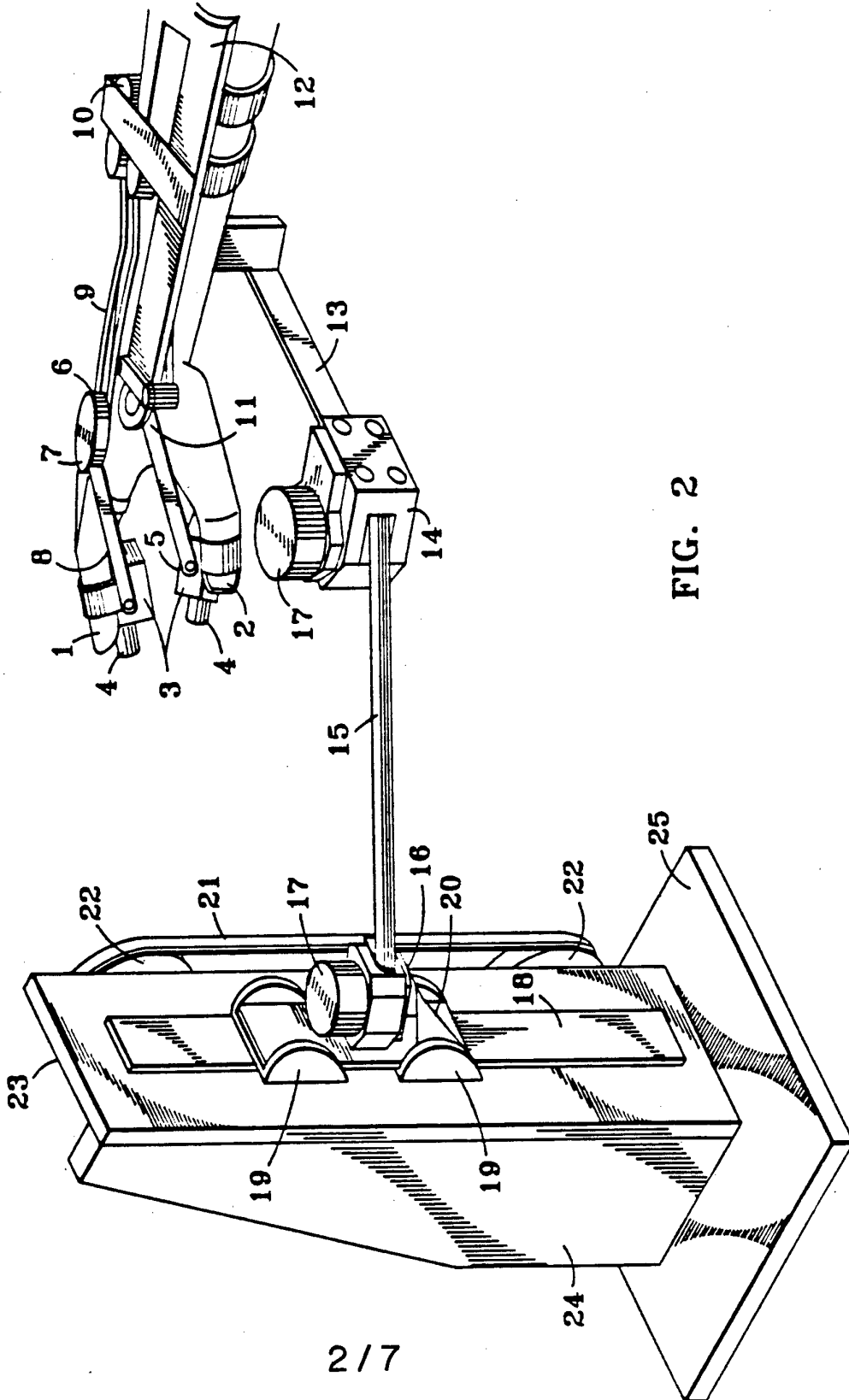

FIG. 2

FIG. 3

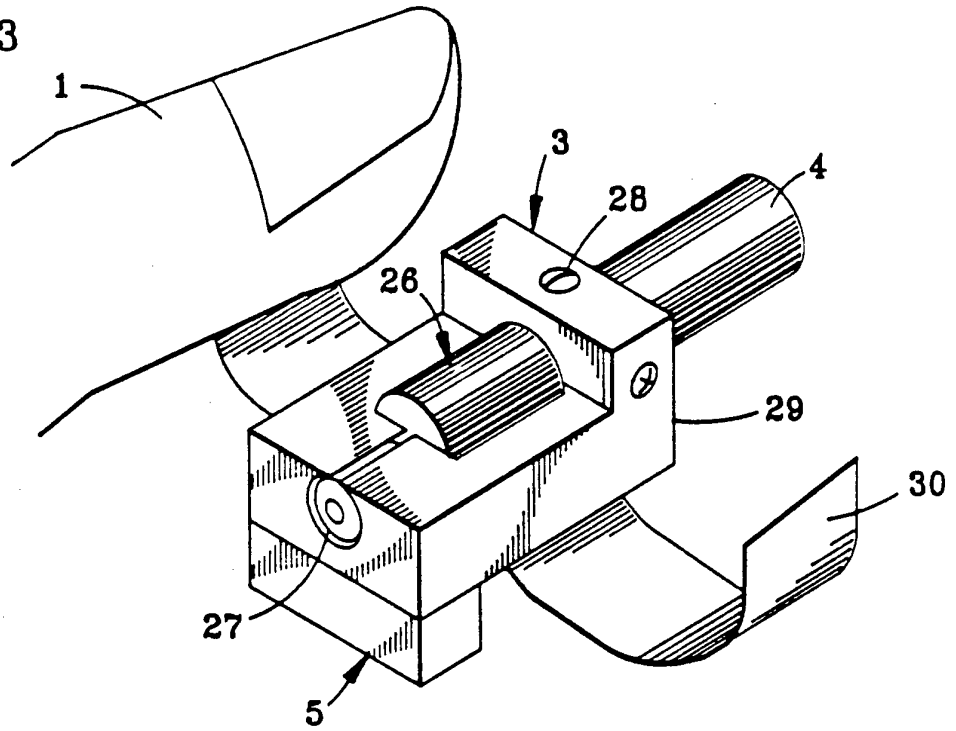

FIG. 4

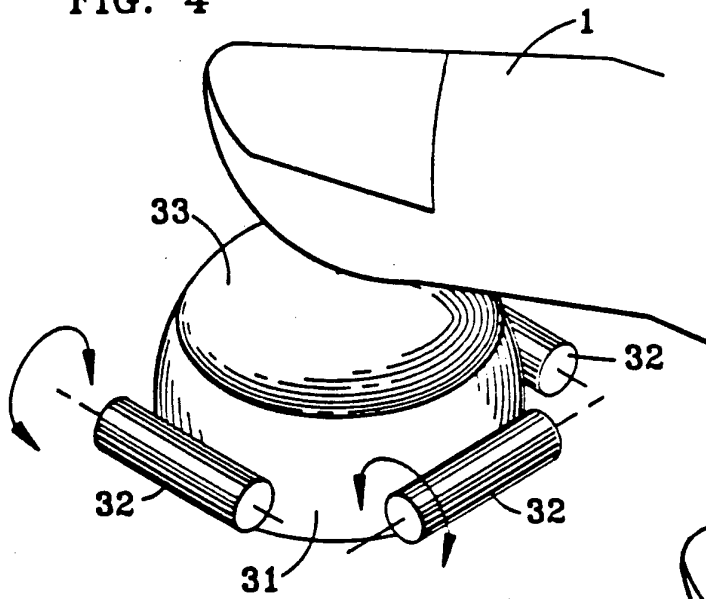
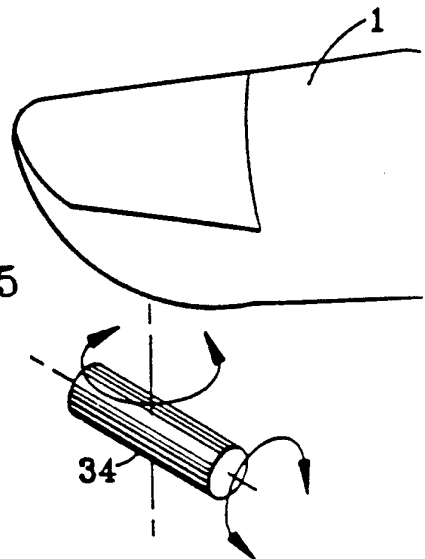

FIG. 5



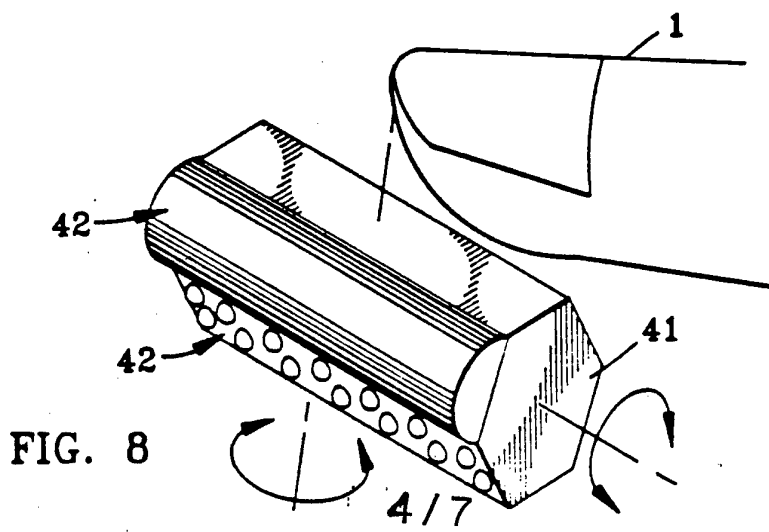
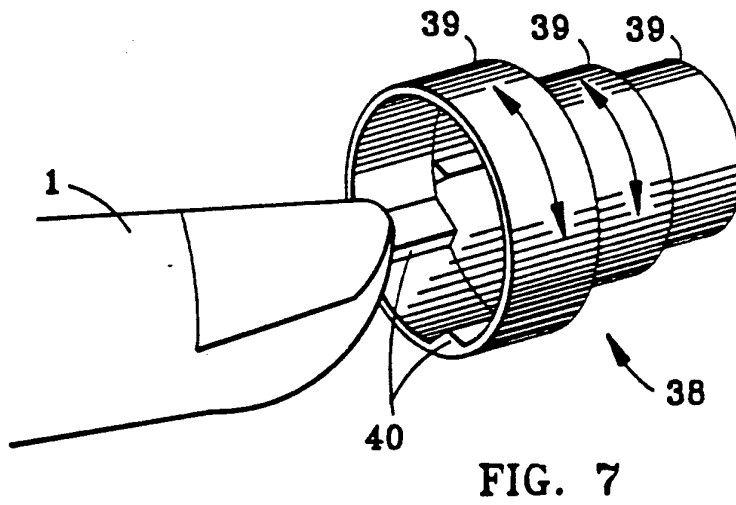
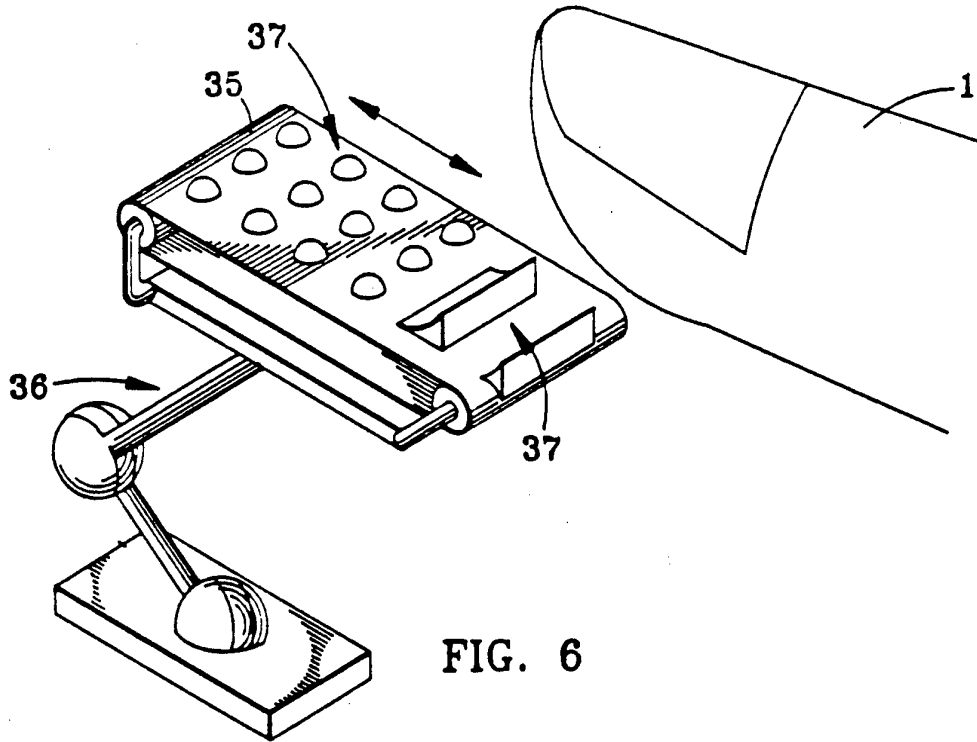

FIG. 9

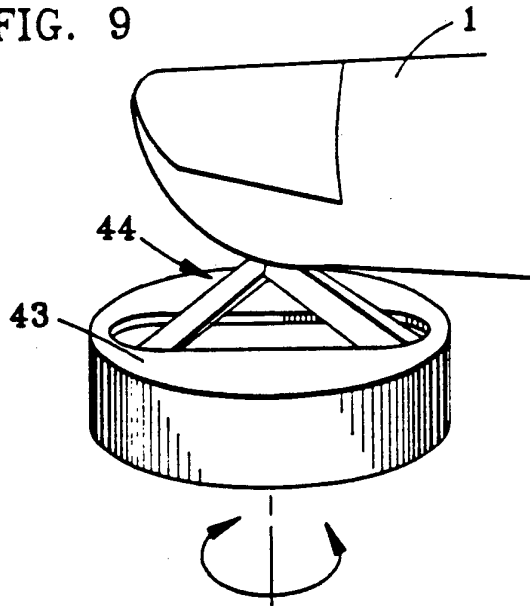

FIG. 10

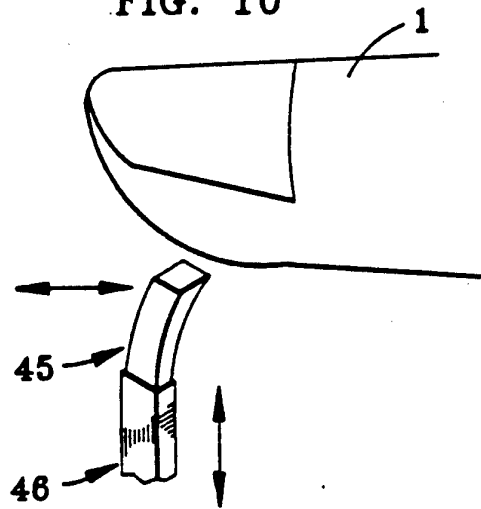
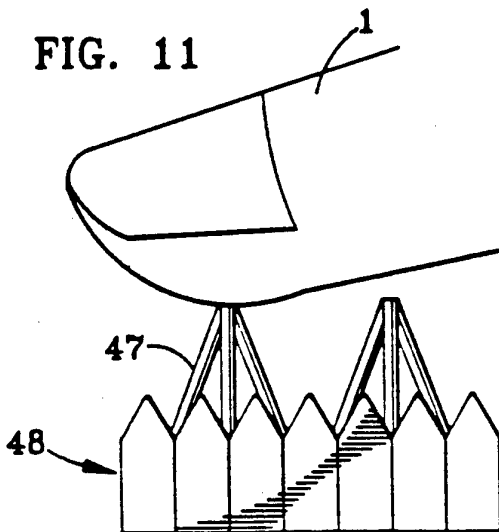

FIG. 11



5 / 7

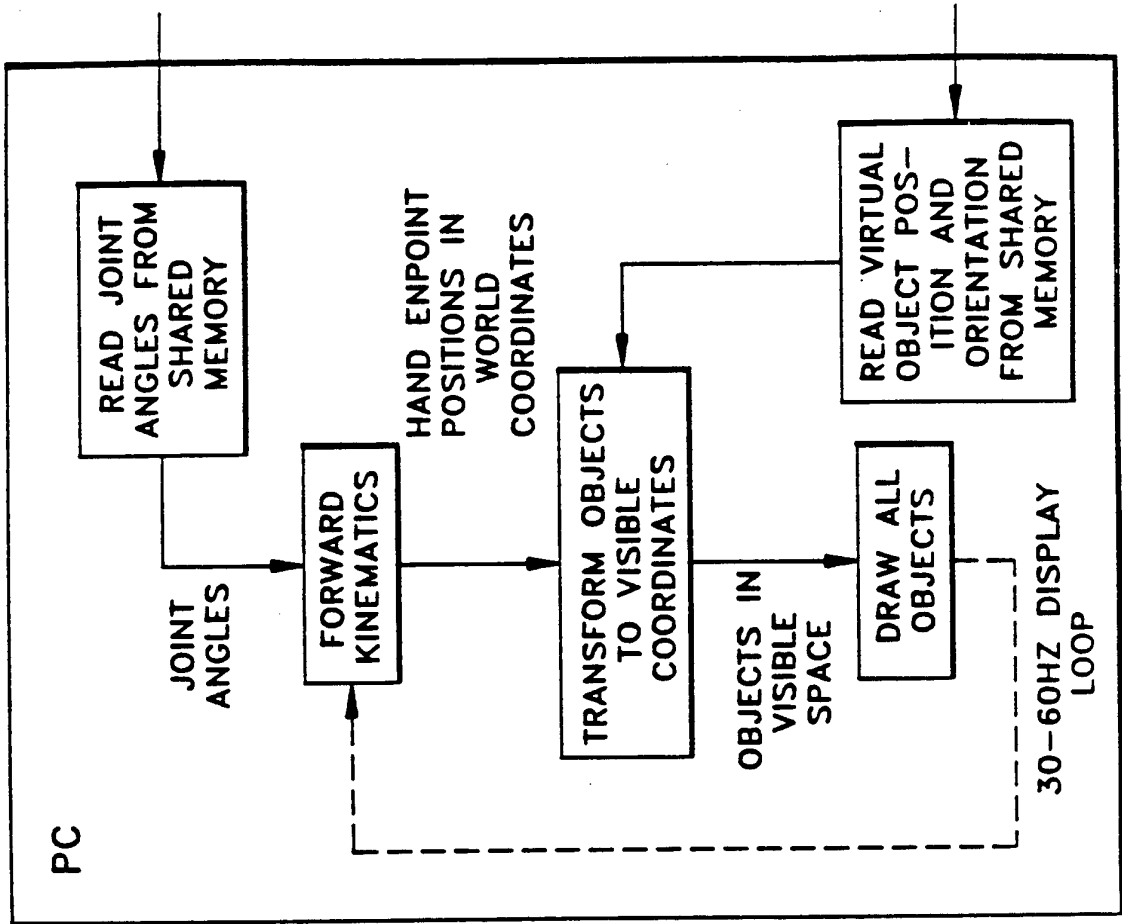
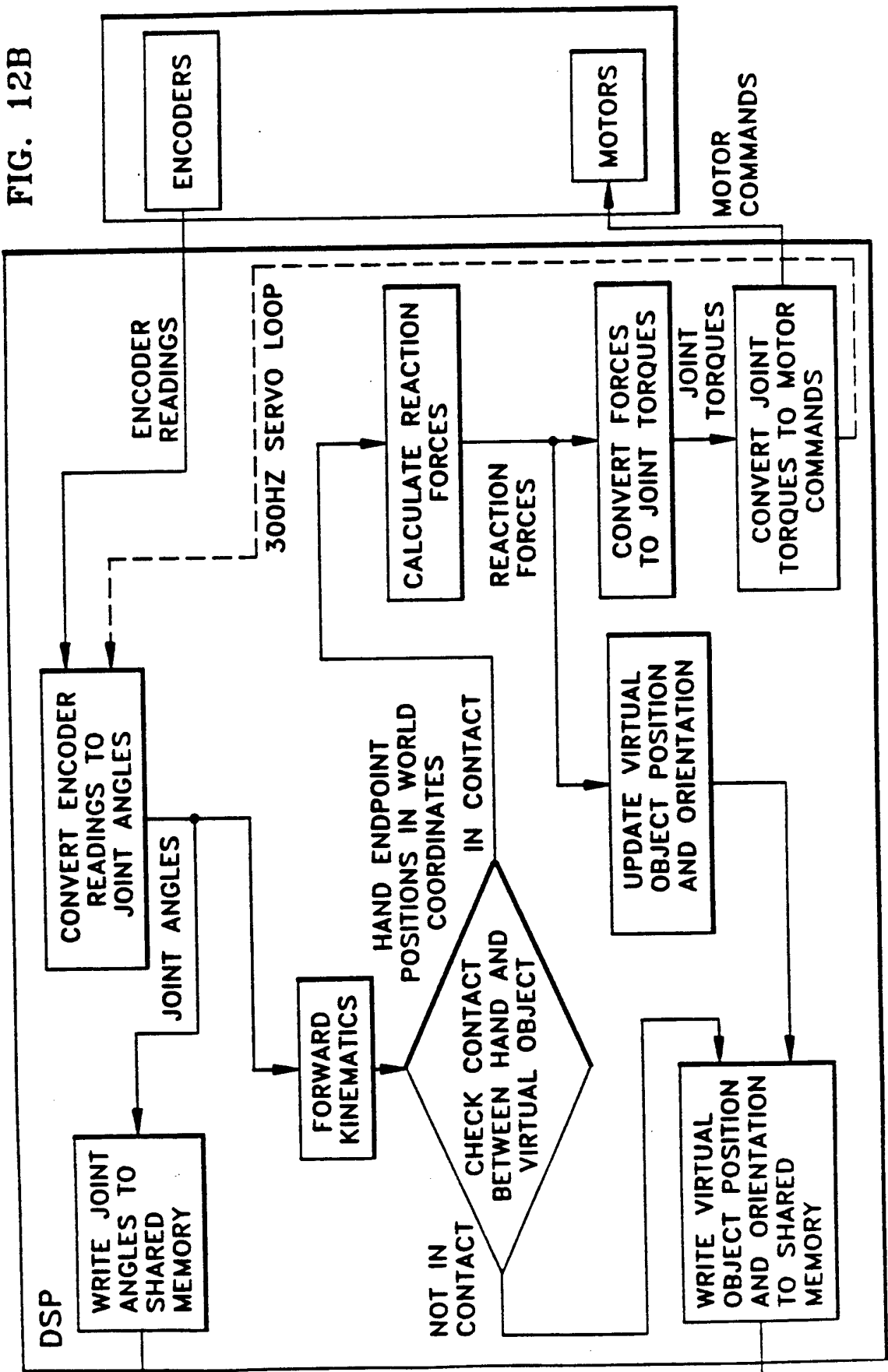

FIG. 12A

FIG. 12
FIG. 12A
FIG. 12B



INTERNATIONAL SEARCH REPORT

Inter. Patent Application No
PCT/US 95/01226

A. CLASSIFICATION OF SUBJECT MATTER
IPC 6 G06F3/00

According to International Patent Classification (IPC) or to both national classification and IPC

B. FIELDS SEARCHED

Minimum documentation searched (classification system followed by classification symbols)
IPC 6 G06F B25J

Documentation searched other than minimum documentation to the extent that such documents are included in the fields searched

Electronic data base consulted during the international search (name of data base and, where practical, search terms used)

C. DOCUMENTS CONSIDERED TO BE RELEVANT

Category *	Citation of document, with indication, where appropriate, of the relevant passages	Relevant to claim No.
X	WO,A,91 11775 (KRAMER JAMES F) 8 August 1991 see page 4, line 24 - page 5, line 34 see page 6, line 12 - page 7, line 13 see abstract	1
A	---	3
X	IEEE INTERNATIONAL CONFERENCE ON ROBOTICS AND AUTOMATION, vol. 1, May 1993 GA,USA, pages 955-960, CALDWELL D. G. ET AL 'Enhanced Tactile Feedback (Tele-Taction) using a Multi-Functional Sensory System' see page 955, left column, line 17 - page 958, right column, line 33	1
A	---	3
	-/--	

Further documents are listed in the continuation of box C.

Patent family members are listed in annex.

* Special categories of cited documents :

- *A* document defining the general state of the art which is not considered to be of particular relevance
- *E* earlier document but published on or after the international filing date
- *L* document which may throw doubts on priority claim(s) or which is cited to establish the publication date of another citation or other special reason (as specified)
- *O* document referring to an oral disclosure, use, exhibition or other means
- *P* document published prior to the international filing date but later than the priority date claimed

- *T* later document published after the international filing date or priority date and not in conflict with the application but cited to understand the principle or theory underlying the invention
- *X* document of particular relevance; the claimed invention cannot be considered novel or cannot be considered to involve an inventive step when the document is taken alone
- *Y* document of particular relevance; the claimed invention cannot be considered to involve an inventive step when the document is combined with one or more other such documents, such combination being obvious to a person skilled in the art.
- * & * document member of the same patent family

Date of the actual completion of the international search

19 May 1995

Date of mailing of the international search report

29.05.95

Name and mailing address of the ISA
European Patent Office, P.B. 5818 Patentlaan 2
NL - 2280 HV Rijswijk
Tel. (+31-70) 340-2040, Tx. 31 651 epo nl,
Fax: (+31-70) 340-3016

Authorized officer

Bailas, A

INTERNATIONAL SEARCH REPORT

Inter. Appl. Application No
PCT/US 95/01226

C.(Continuation) DOCUMENTS CONSIDERED TO BE RELEVANT		
Category *	Citation of document, with indication, where appropriate, of the relevant passages	Relevant to claim No.
X	<p>IEEE VIRTUAL REALITY ANNUAL INTERNATIONAL SYMPOSIUM, 18 September 1993 SEATTLE, WA, pages 256-262, XP 000457695 HIROTA K. ET AL 'Development of Surface Display' see page 256, line 14 - page 257, line 16 see page 258, line 1 - page 259, line 11 see page 261, line 4 - line 21 -----</p>	1

INTERNATIONAL SEARCH REPORT

Information on patent family members

Inter. Application No

PCT/US 95/01226

Patent document cited in search report	Publication date	Patent family member(s)	Publication date
WO-A-9111775	08-08-91	US-A- 5184319	02-02-93
		AU-B- 5752394	28-04-94
		AU-B- 649655	02-06-94
		AU-A- 7319991	21-08-91
		EP-A- 0513199	19-11-92
