

(12) STANDARD PATENT
(19) AUSTRALIAN PATENT OFFICE

(11) Application No. **AU 2012225621 B2**

- (54) Title
Secure file sharing method and system
- (51) International Patent Classification(s)
H04L 9/08 (2006.01) **H04L 29/06** (2006.01)
G06F 21/00 (2006.01)
- (21) Application No: **2012225621** (22) Date of Filing: **2012.03.06**
- (87) WIPO No: **WO12/122175**
- (30) Priority Data
- (31) Number (32) Date (33) Country
61/450,110 **2011.03.07** **US**
- (43) Publication Date: **2012.09.13**
(44) Accepted Journal Date: **2015.10.29**
- (71) Applicant(s)
Security First Corp.
- (72) Inventor(s)
O'Hare, Mark S.;Orsini, Rick L.;Martin, Don
- (74) Agent / Attorney
Cullens Patent and Trade Mark Attorneys, Level 32 239 George Street, Brisbane, QLD, 4000
- (56) Related Art
EP 0695997
US 2009/0177894
WO 2009/121658 & US 2011/0123027



- (51) **International Patent Classification:**
H04L 9/08 (2006.01) *H04L 29/06* (2006.01)
G06F 21/00 (2006.01)
 - (21) **International Application Number:** PCT/US2012/027893
 - (22) **International Filing Date:** 6 March 2012 (06.03.2012)
 - (25) **Filing Language:** English
 - (26) **Publication Language:** English
 - (30) **Priority Data:**
61/450,110 7 March 2011 (07.03.2011) US
 - (71) **Applicant (for all designated States except US):** SECURITY FIRST CORP. [US/US]; 29811 Santa Margarita Parkway, Suite 600, Rancho Santa Margarita, CA 92688 (US).
 - (72) **Inventor; and**
 - (71) **Applicant :** O'HARE, Mark, S. [US/US]; 8 Kennedy Court, Coto De Caza, CA 92679 (US).
 - (72) **Inventor; and**
 - (75) **Inventor/Applicant (for US only):** ORSINI, Rick, L. [US/US]; 2100 Kings Forest Lane, Flower Mound, TX 75028 (US).
 - (74) **Agents:** INGERMAN, Jeffrey et al.; Ropes & Gray LLP, Prudential Tower, 800 Boylston Street, Boston, MA 02199 (US).
 - (81) **Designated States (unless otherwise indicated, for every kind of national protection available):** AE, AG, AL, AM, AO, AT, AU, AZ, BA, BB, BG, BH, BR, BW, BY, BZ, CA, CH, CL, CN, CO, CR, CU, CZ, DE, DK, DM, DO, DZ, EC, EE, EG, ES, FI, GB, GD, GE, GH, GM, GT, HN, HR, HU, ID, IL, IN, IS, JP, KE, KG, KM, KN, KP, KR, KZ, LA, LC, LK, LR, LS, LT, LU, LY, MA, MD, ME, MG, MK, MN, MW, MX, MY, MZ, NA, NG, NI, NO, NZ, OM, PE, PG, PH, PL, PT, QA, RO, RS, RU, RW, SC, SD, SE, SG, SK, SL, SM, ST, SV, SY, TH, TJ, TM, TN, TR, TT, TZ, UA, UG, US, UZ, VC, VN, ZA, ZM, ZW.
 - (84) **Designated States (unless otherwise indicated, for every kind of regional protection available):** ARIPO (BW, GH, GM, KE, LR, LS, MW, MZ, NA, RW, SD, SL, SZ, TZ, UG, ZM, ZW), Eurasian (AM, AZ, BY, KG, KZ, MD, RU, TJ, TM), European (AL, AT, BE, BG, CH, CY, CZ, DE, DK, EE, ES, FI, FR, GB, GR, HR, HU, IE, IS, IT, LT, LU, LV, MC, MK, MT, NL, NO, PL, PT, RO, RS, SE, SI, SK, SM, TR), OAPI (BF, BJ, CF, CG, CI, CM, GA, GN, GQ, GW, ML, MR, NE, SN, TD, TG).
- Published:**
— with international search report (Art. 21(3))

WO 2012/122175 A1

(54) Title: SECURE FILE SHARING METHOD AND SYSTEM

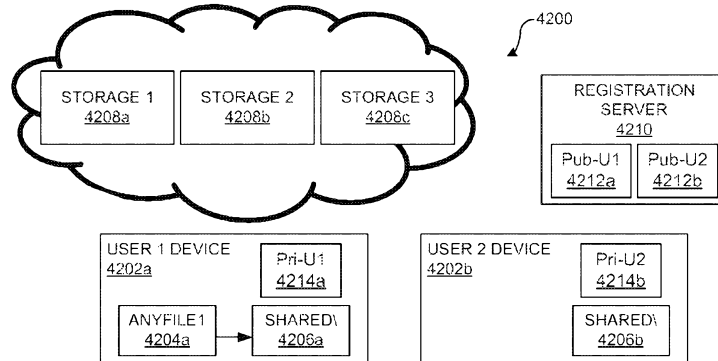

FIGURE 42A

(57) **Abstract:** Systems and methods are provided for securely sharing data. A processor forms two or more shares of a data set encrypted with a symmetric key, the data set associated with a first user device, and causes the encrypted data set shares to be stored separately from each other in at least one remote storage location. The processor generates first and second encrypted keys by encrypting data indicative of the symmetric key with a first asymmetric key of first and second asymmetric key pairs associated with the first user device and a second user device, respectively, and causes the encrypted key to be stored in the at least one storage location. To restore the data set, a predetermined number of the two or more encrypted data set shares and at least one of the second asymmetric keys of the first and second asymmetric key pairs are needed.

SECURE FILE SHARING METHOD AND SYSTEM

Cross-Reference to Related Application

[0001] This application claims priority to U.S. Provisional Application No. 61/450,110, filed March 7, 2011, the content of which is incorporated by reference herein in its entirety.

Summary

[0002] Described herein are systems and methods for securely sharing data and accessing securely shared data. In some aspects, a method for securely sharing data is provided, the method steps implemented by a programmed computer system. Two or more shares of an encrypted data set are formed. The encrypted data set is representative of a data set associated with a first user device and is encrypted with a symmetric key. Each encrypted data set share includes a portion of data from the encrypted data set, and the two or more encrypted data set shares are caused to be stored separately from each other in at least one storage location. The at least one storage location may include a cloud computing storage location. A first encrypted key is generated by encrypting data indicative of the symmetric key with a first asymmetric key of a first asymmetric key pair associated with the first user device. A second encrypted key is generated by encrypting data indicative of the symmetric key with a first asymmetric key of a second asymmetric key pair associated with a second user device. In some implementations, the method includes accessing the first asymmetric key of the second asymmetric key pair from a registration server prior to generating the second encrypted key. The first and second encrypted keys are caused to be stored in the at least one storage location, which is remote to both the first and second user devices. To restore the data set, a predetermined number of the two or more encrypted data set shares and at least one of a second asymmetric key of the first asymmetric key pair and a second asymmetric key of the second asymmetric key pair are needed.

[0003] In some implementations, the data indicative of the symmetric key is the symmetric key. In some implementations, the data indicative of the symmetric key is the symmetric key encrypted with a workgroup key. In some such implementations, the workgroup key is needed to restore the data set. The second user device may be associated with a workgroup that has access to the workgroup key.

[0004] In some implementations, the method includes forming two or more shares of the first and second encrypted keys, each encrypted key share including a portion of data from the first and second encrypted keys. In some such implementations, causing the first and second

encrypted keys to be stored in the at least one storage location includes causing the two or more encrypted key shares to be stored separately from each other in the at least one storage location. To restore the first and second encrypted keys, a predetermined number of the two or more encrypted key shares is needed.

[0005] In some implementations, the method includes generating a plurality of encrypted keys by, for each of a plurality of first asymmetric keys of a corresponding plurality of asymmetric key pairs associated with a corresponding plurality of user devices, encrypting the data indicative of the symmetric key with the first asymmetric key. The plurality of encrypted keys are caused to be stored in the at least one storage location (which may include transmitting the plurality of encrypted keys in a header of each of the two or more encrypted data set shares). To restore the data set, the predetermined number of the two or more encrypted data set shares and at least one of the second asymmetric key of the first asymmetric key pair, the second asymmetric key of the second asymmetric key pair, and the plurality of second encryption keys of the plurality of asymmetric key pairs are needed.

[0006] In some aspects, a method for accessing a securely shared data set is provided, the method steps implemented by a programmed computer system. A first encrypted key stored in at least one storage location is accessed. The first encrypted key includes data indicative of a symmetric key encrypted with a first asymmetric key of a first asymmetric key pair associated with a first user device. In some implementations, the first asymmetric key of the first asymmetric key pair is provided to a registration server prior to accessing the first encrypted key. The at least one storage location is remote from the first user device and remote from a second user device different from the first user device. The at least one storage location also stores a second encrypted key comprising data indicative of the symmetric key encrypted with a first asymmetric key of a second asymmetric key pair associated with the second user device. The data indicative of the symmetric key is restored by decrypting the first encrypted key using a second asymmetric key of the first asymmetric key pair. A predetermined number of two or more encrypted data set shares stored in the at least one storage location(encrypted with the symmetric key by the second user device) are accessed. The data set is then restored using the predetermined number of encrypted data set .

[0007] In some aspects, a method for securely sharing data is provided, the method steps implemented by a programmed computer system. Two or more shares of an encrypted data set are formed, the encrypted data set representative of a data set associated with a first user device and encrypted with a symmetric key. Each encrypted data set share includes a portion of data from the encrypted data set. For each of a plurality of user devices including the first

user device, an encrypted key is generated by encrypting data indicative of the symmetric key with a first asymmetric key of an asymmetric key pair associated with the user device. For each of the two or more encrypted data set shares, the plurality of encrypted keys is distributed in a header of the encrypted data set share, and the two or more encrypted data set shares and headers are caused to be stored in at least one storage location. To restore the data set, a predetermined number of the two or more encrypted data set shares and a second asymmetric key of at least one of the plurality of asymmetric key pairs are needed to restore the data set.

[0008] Systems and computer-readable media configured to execute the methods disclosed herein are also provided.

Brief Description of the Drawings

[0009] The present invention is described in more detail below in connection with the attached drawings, which are meant to illustrate and not to limit the invention, and in which:

[0010] FIGURE 1 illustrates a block diagram of a cryptographic system, according to aspects of an embodiment of the invention;

[0011] FIGURE 2 illustrates a block diagram of the trust engine of FIGURE 1, according to aspects of an embodiment of the invention;

[0012] FIGURE 3 illustrates a block diagram of the transaction engine of FIGURE 2, according to aspects of an embodiment of the invention;

[0013] FIGURE 4 illustrates a block diagram of the depository of FIGURE 2, according to aspects of an embodiment of the invention;

[0014] FIGURE 5 illustrates a block diagram of the authentication engine of FIGURE 2, according to aspects of an embodiment of the invention;

[0015] FIGURE 6 illustrates a block diagram of the cryptographic engine of FIGURE 2, according to aspects of an embodiment of the invention;

[0016] FIGURE 7 illustrates a block diagram of a depository system, according to aspects of another embodiment of the invention;

[0017] FIGURE 8 illustrates a flow chart of a data splitting process according to aspects of an embodiment of the invention;

[0018] FIGURE 9, Panel A illustrates a data flow of an enrollment process according to aspects of an embodiment of the invention;

[0019] FIGURE 9, Panel B illustrates a flow chart of an interoperability process according to aspects of an embodiment of the invention;

- [0020]** FIGURE 10 illustrates a data flow of an authentication process according to aspects of an embodiment of the invention;
- [0021]** FIGURE 11 illustrates a data flow of a signing process according to aspects of an embodiment of the invention;
- [0022]** FIGURE 12 illustrates a data flow and an encryption/decryption process according to aspects and yet another embodiment of the invention;
- [0023]** FIGURE 13 illustrates a simplified block diagram of a trust engine system according to aspects of another embodiment of the invention;
- [0024]** FIGURE 14 illustrates a simplified block diagram of a trust engine system according to aspects of another embodiment of the invention;
- [0025]** FIGURE 15 illustrates a block diagram of the redundancy module of FIGURE 14, according to aspects of an embodiment of the invention;
- [0026]** FIGURE 16 illustrates a process for evaluating authentications according to one aspect of the invention;
- [0027]** FIGURE 17 illustrates a process for assigning a value to an authentication according to one aspect as shown in FIGURE 16 of the invention;
- [0028]** FIGURE 18 illustrates a process for performing trust arbitrage in an aspect of the invention as shown in FIGURE 17; and
- [0029]** FIGURE 19 illustrates a sample transaction between a user and a vendor according to aspects of an embodiment of the invention where an initial web based contact leads to a sales contract signed by both parties.
- [0030]** FIGURE 20 illustrates a sample user system with a cryptographic service provider module which provides security functions to a user system.
- [0031]** FIGURE 21 illustrates a process for parsing, splitting and/or separating data with encryption and storage of the encryption master key with the data.
- [0032]** FIGURE 22 illustrates a process for parsing, splitting and/or separating data with encryption and storing the encryption master key separately from the data.
- [0033]** FIGURE 23 illustrates the intermediary key process for parsing, splitting and/or separating data with encryption and storage of the encryption master key with the data.
- [0034]** FIGURE 24 illustrates the intermediary key process for parsing, splitting and/or separating data with encryption and storing the encryption master key separately from the data.
- [0035]** FIGURE 25 illustrates utilization of the cryptographic methods and systems of the present invention with a small working group.

- [0036]** FIGURE 26 is a block diagram of an illustrative physical token security system employing the secure data parser in accordance with one embodiment of the present invention.
- [0037]** FIGURE 27 is a block diagram of an illustrative arrangement in which the secure data parser is integrated into a system in accordance with one embodiment of the present invention.
- [0038]** FIGURE 28 is a block diagram of an illustrative data in motion system in accordance with one embodiment of the present invention.
- [0039]** FIGURE 29 is a block diagram of another illustrative data in motion system in accordance with one embodiment of the present invention.
- [0040]** FIGURES 30-32 are block diagrams of an illustrative system having the secure data parser integrated in accordance with one embodiment of the present invention.
- [0041]** FIGURE 33 is a process flow diagram of an illustrative process for parsing and splitting data in accordance with one embodiment of the present invention.
- [0042]** FIGURE 34 is a process flow diagram of an illustrative process for restoring portions of data into original data in accordance with one embodiment of the present invention.
- [0043]** FIGURE 35 is a process flow diagram of an illustrative process for splitting data at the bit level in accordance with one embodiment of the present invention.
- [0044]** FIGURE 36 is a process flow diagram of illustrative steps and features in accordance with one embodiment of the present invention.
- [0045]** FIGURE 37 is a process flow diagram of illustrative steps and features in accordance with one embodiment of the present invention.
- [0046]** FIGURE 38 is a simplified block diagram of the storage of key and data components within shares in accordance with one embodiment of the present invention.
- [0047]** FIGURE 39 is a simplified block diagram of the storage of key and data components within shares using a workgroup key in accordance with one embodiment of the present invention.
- [0048]** FIGURES 40A and 40B are simplified and illustrative process flow diagrams for header generation and data splitting for data in motion in accordance with one embodiment of the present invention.
- [0049]** FIGURE 41 is a simplified block diagram of an illustrative share format in accordance with one embodiment of the present invention.
- [0050]** FIGURES 42A-E are block diagrams depicting the operation of an illustrative secure sharing system in accordance with one embodiment of the present invention.

[0051] FIGURE 43 illustrates an implementation in which a cryptographic sharing client of a user device is configured to perform a combined sharing operation to securely share a data set with a plurality of users in accordance with one embodiment of the present invention.

[0052] FIGURE 44 is a flow diagram of illustrative steps of a method for securely sharing data in accordance with one embodiment of the present invention.

[0053] FIGURE 45 is a flow diagram of illustrative sub-steps that a processor may perform in the course of performing step 4410 of FIGURE 44, in accordance with one embodiment of the present invention.

[0054] FIGURE 46 is a flow diagram of illustrative steps of a method for accessing a data set shared securely according to the method illustrated in FIGURE 44, in accordance with one embodiment of the present invention.

[0055] FIGURE 47 is a flow diagram of illustrative steps of a method for securely sharing data in accordance with one embodiment of the present invention.

Detailed Description

[0056] The systems and methods described herein may be used in conjunction with other systems and methods described in commonly-owned U.S. Patent No. 7,391,865 and commonly-owned U.S. Patent Application Nos. 11/258,839, filed October 25, 2005, 11/602,667, filed November 20, 2006, 11/983,355, filed November 7, 2007, 11/999,575, filed December 5, 2007, 12/148,365, filed April 18, 2008, 12/209,703, filed September 12, 2008, 12/349,897, filed January 7, 2009, 12/391,028, filed February 23, 2009, 12/783,276, filed May 19, 2010, 12/953,877, filed November 24, 2010, and U.S. Provisional Patent Application Nos. 61/436,991, filed January 27, 2011, 61/264,464, filed November 25, 2009, 61/319,658, filed March 31, 2010, 61/320,242, filed April 1, 2010, 61/349,560, filed May 28, 2010, 61/373,187, filed August 12, 2010, 61/374,950, filed August 18, 2010, and 61/384,583, filed September 20, 2010. The disclosures of each of the aforementioned, earlier-filed applications are hereby incorporated by reference herein in their entireties.

[0057] One aspect of the present invention is to provide a cryptographic system where one or more secure servers, or a trust engine, stores cryptographic keys and user authentication data. Users access the functionality of conventional cryptographic systems through network access to the trust engine, however, the trust engine does not release actual keys and other authentication data and therefore, the keys and data remain secure. This server-centric storage

of keys and authentication data provides for user-independent security, portability, availability, and straightforwardness.

[0058] Because users can be confident in, or trust, the cryptographic system to perform user and document authentication and other cryptographic functions, a wide variety of functionality may be incorporated into the system. For example, the trust engine provider can ensure against agreement repudiation by, for example, authenticating the agreement participants, digitally signing the agreement on behalf of or for the participants, and storing a record of the agreement digitally signed by each participant. In addition, the cryptographic system may monitor agreements and determine to apply varying degrees of authentication, based on, for example, price, user, vendor, geographic location, place of use, or the like.

[0059] To facilitate a complete understanding of the invention, the remainder of the detailed description describes the invention with reference to the figures, wherein like elements are referenced with like numerals throughout.

[0060] FIGURE 1 illustrates a block diagram of a cryptographic system 100, according to aspects of an embodiment of the invention. As shown in FIGURE 1, the cryptographic system 100 includes a user system 105, a trust engine 110, a certificate authority 115, and a vendor system 120, communicating through a communication link 125.

[0061] According to one embodiment of the invention, the user system 105 comprises a conventional general-purpose computer having one or more microprocessors, such as, for example, an Intel-based processor. Moreover, the user system 105 includes an appropriate operating system, such as, for example, an operating system capable of including graphics or windows, such as Windows, Unix, Linux, or the like. As shown in FIGURE 1, the user system 105 may include a biometric device 107. The biometric device 107 may advantageously capture a user's biometric and transfer the captured biometric to the trust engine 110. According to one embodiment of the invention, the biometric device may advantageously comprise a device having attributes and features similar to those disclosed in U.S. Patent Application No. 08/926,277, filed on September 5, 1997, entitled "RELIEF OBJECT IMAGE GENERATOR," U.S. Patent Application No. 09/558,634, filed on April 26, 2000, entitled "IMAGING DEVICE FOR A RELIEF OBJECT AND SYSTEM AND METHOD OF USING THE IMAGE DEVICE," U.S. Patent Application No. 09/435,011, filed on November 5, 1999, entitled "RELIEF OBJECT SENSOR ADAPTOR," and U.S. Patent Application No. 09/477,943, filed on January 5, 2000, entitled "PLANAR OPTICAL IMAGE SENSOR AND SYSTEM FOR GENERATING AN ELECTRONIC IMAGE OF A RELIEF

OBJECT FOR FINGERPRINT READING," all of which are owned by the instant assignee, and all of which are hereby incorporated by reference herein.

[0062] In addition, the user system 105 may connect to the communication link 125 through a conventional service provider, such as, for example, a dial up, digital subscriber line (DSL), cable modem, fiber connection, or the like. According to another embodiment, the user system 105 connects the communication link 125 through network connectivity such as, for example, a local or wide area network. According to one embodiment, the operating system includes a TCP/IP stack that handles all incoming and outgoing message traffic passed over the communication link 125.

[0063] Although the user system 105 is disclosed with reference to the foregoing embodiments, the invention is not intended to be limited thereby. Rather, a skilled artisan will recognize from the disclosure herein, a wide number of alternatives embodiments of the user system 105, including almost any computing device capable of sending or receiving information from another computer system. For example, the user system 105 may include, but is not limited to, a computer workstation, an interactive television, an interactive kiosk, a personal mobile computing device, such as a digital assistant, mobile phone, laptop, or the like, personal networking equipment, such as a home router, a network storage device ("NAS"), personal hotspot, or the like, or a wireless communications device, a smartcard, an embedded computing device, or the like, which can interact with the communication link 125. In such alternative systems, the operating systems will likely differ and be adapted for the particular device. However, according to one embodiment, the operating systems advantageously continue to provide the appropriate communications protocols needed to establish communication with the communication link 125.

[0064] FIGURE 1 illustrates the trust engine 110. According to one embodiment, the trust engine 110 comprises one or more secure servers for accessing and storing sensitive information, which may be any type or form of data, such as, but not limited to text, audio, video, user authentication data and public and private cryptographic keys. According to one embodiment, the authentication data includes data designed to uniquely identify a user of the cryptographic system 100. For example, the authentication data may include a user identification number, one or more biometrics, and a series of questions and answers generated by the trust engine 110 or the user, but answered initially by the user at enrollment. The foregoing questions may include demographic data, such as place of birth, address, anniversary, or the like, personal data, such as mother's maiden name, favorite ice cream, or the like, or other data designed to uniquely identify the user. The trust engine 110 compares a

user's authentication data associated with a current transaction, to the authentication data provided at an earlier time, such as, for example, during enrollment. The trust engine 110 may advantageously require the user to produce the authentication data at the time of each transaction, or, the trust engine 110 may advantageously allow the user to periodically produce authentication data, such as at the beginning of a string of transactions or the logging onto a particular vendor website.

[0065] According to the embodiment where the user produces biometric data, the user provides a physical characteristic, such as, but not limited to, facial scan, hand scan, ear scan, iris scan, retinal scan, vascular pattern, DNA, a fingerprint, writing or speech, to the biometric device 107. The biometric device advantageously produces an electronic pattern, or biometric, of the physical characteristic. The electronic pattern is transferred through the user system 105 to the trust engine 110 for either enrollment or authentication purposes.

[0066] Once the user produces the appropriate authentication data and the trust engine 110 determines a positive match between that authentication data (current authentication data) and the authentication data provided at the time of enrollment (enrollment authentication data), the trust engine 110 provides the user with complete cryptographic functionality. For example, the properly authenticated user may advantageously employ the trust engine 110 to perform hashing, digitally signing, encrypting and decrypting (often together referred to only as encrypting), creating or distributing digital certificates, and the like. However, the private cryptographic keys used in the cryptographic functions will not be available outside the trust engine 110, thereby ensuring the integrity of the cryptographic keys.

[0067] According to one embodiment, the trust engine 110 generates and stores cryptographic keys. According to another embodiment, at least one cryptographic key is associated with each user. Moreover, when the cryptographic keys include public-key technology, each private key associated with a user is generated within, and not released from, the trust engine 110. Thus, so long as the user has access to the trust engine 110, the user may perform cryptographic functions using his or her private or public key. Such remote access advantageously allows users to remain completely mobile and access cryptographic functionality through practically any Internet connection, such as cellular and satellite phones, kiosks, laptops, hotel rooms and the like.

[0068] According to another embodiment, the trust engine 110 performs the cryptographic functionality using a key pair generated for the trust engine 110. According to this embodiment, the trust engine 110 first authenticates the user, and after the user has properly produced authentication data matching the enrollment authentication data, the trust

engine 110 uses its own cryptographic key pair to perform cryptographic functions on behalf of the authenticated user.

[0069] A skilled artisan will recognize from the disclosure herein that the cryptographic keys may advantageously include some or all of symmetric keys, public keys, and private keys. In addition, a skilled artisan will recognize from the disclosure herein that the foregoing keys may be implemented with a wide number of algorithms available from commercial technologies, such as, for example, RSA, ELGAMAL, or the like.

[0070] FIGURE 1 also illustrates the certificate authority 115. According to one embodiment, the certificate authority 115 may advantageously comprise a trusted third-party organization or company that issues digital certificates, such as, for example, VeriSign, Baltimore, Entrust, or the like. The trust engine 110 may advantageously transmit requests for digital certificates, through one or more conventional digital certificate protocols, such as, for example, PKCS10, to the certificate authority 115. In response, the certificate authority 115 will issue a digital certificate in one or more of a number of differing protocols, such as, for example, PKCS7. According to one embodiment of the invention, the trust engine 110 requests digital certificates from several or all of the prominent certificate authorities 115 such that the trust engine 110 has access to a digital certificate corresponding to the certificate standard of any requesting party.

[0071] According to another embodiment, the trust engine 110 internally performs certificate issuances. In this embodiment, the trust engine 110 may access a certificate system for generating certificates and/or may internally generate certificates when they are requested, such as, for example, at the time of key generation or in the certificate standard requested at the time of the request. The trust engine 110 will be disclosed in greater detail below.

[0072] FIGURE 1 also illustrates the vendor system 120. According to one embodiment, the vendor system 120 advantageously comprises a Web server. Typical Web servers generally serve content over the Internet using one of several internet markup languages or document format standards, such as the Hyper-Text Markup Language (HTML) or the Extensible Markup Language (XML). The Web server accepts requests from browsers like Netscape and Internet Explorer and then returns the appropriate electronic documents. A number of server or client-side technologies can be used to increase the power of the Web server beyond its ability to deliver standard electronic documents. For example, these technologies include Common Gateway Interface (CGI) scripts, SSL security, and Active Server Pages (ASPs). The vendor system 120 may advantageously provide electronic content relating to commercial, personal, educational, or other transactions.

[0073] Although the vendor system 120 is disclosed with reference to the foregoing embodiments, the invention is not intended to be limited thereby. Rather, a skilled artisan will recognize from the disclosure herein that the vendor system 120 may advantageously comprise any of the devices described with reference to the user system 105 or combination thereof.

[0074] FIGURE 1 also illustrates the communication link 125 connecting the user system 105, the trust engine 110, the certificate authority 115, and the vendor system 120. According to one embodiment, the communication link 125 preferably comprises the Internet. The Internet, as used throughout this disclosure is a global network of computers. The structure of the Internet, which is well known to those of ordinary skill in the art, includes a network backbone with networks branching from the backbone. These branches, in turn, have networks branching from them, and so on. Routers move information packets between network levels, and then from network to network, until the packet reaches the neighborhood of its destination. From the destination, the destination network's host directs the information packet to the appropriate terminal, or node. In one advantageous embodiment, the Internet routing hubs comprise domain name system (DNS) servers using Transmission Control Protocol/Internet Protocol (TCP/IP) as is well known in the art. The routing hubs connect to one or more other routing hubs via high-speed communication links.

[0075] One popular part of the Internet is the World Wide Web. The World Wide Web contains different computers, which store documents capable of displaying graphical and textual information. The computers that provide information on the World Wide Web are typically called "websites." A website is defined by an Internet address that has an associated electronic page. The electronic page can be identified by a Uniform Resource Locator (URL). Generally, an electronic page is a document that organizes the presentation of text, graphical images, audio, video, and so forth.

[0076] Although the communication link 125 is disclosed in terms of its preferred embodiment, one of ordinary skill in the art will recognize from the disclosure herein that the communication link 125 may include a wide range of interactive communications links. For example, the communication link 125 may include interactive television networks, telephone networks, wireless data transmission systems, two-way cable systems, customized private or public computer networks, interactive kiosk networks, automatic teller machine networks, direct links, satellite or cellular networks, and the like.

[0077] FIGURE 2 illustrates a block diagram of the trust engine 110 of FIGURE 1 according to aspects of an embodiment of the invention. As shown in FIGURE 2, the trust

engine 110 includes a transaction engine 205, a depository 210, an authentication engine 215, and a cryptographic engine 220. According to one embodiment of the invention, the trust engine 110 also includes mass storage 225. As further shown in FIGURE 2, the transaction engine 205 communicates with the depository 210, the authentication engine 215, and the cryptographic engine 220, along with the mass storage 225. In addition, the depository 210 communicates with the authentication engine 215, the cryptographic engine 220, and the mass storage 225. Moreover, the authentication engine 215 communicates with the cryptographic engine 220. According to one embodiment of the invention, some or all of the foregoing communications may advantageously comprise the transmission of XML documents to IP addresses that correspond to the receiving device. As mentioned in the foregoing, XML documents advantageously allow designers to create their own customized document tags, enabling the definition, transmission, validation, and interpretation of data between applications and between organizations. Moreover, some or all of the foregoing communications may include conventional SSL technologies.

[0078] According to one embodiment, the transaction engine 205 comprises a data routing device, such as a conventional Web server available from Netscape, Microsoft, Apache, or the like. For example, the Web server may advantageously receive incoming data from the communication link 125. According to one embodiment of the invention, the incoming data is addressed to a front-end security system for the trust engine 110. For example, the front-end security system may advantageously include a firewall, an intrusion detection system searching for known attack profiles, and/or a virus scanner. After clearing the front-end security system, the data is received by the transaction engine 205 and routed to one of the depository 210, the authentication engine 215, the cryptographic engine 220, and the mass storage 225. In addition, the transaction engine 205 monitors incoming data from the authentication engine 215 and cryptographic engine 220, and routes the data to particular systems through the communication link 125. For example, the transaction engine 205 may advantageously route data to the user system 105, the certificate authority 115, or the vendor system 120.

[0079] According to one embodiment, the data is routed using conventional HTTP routing techniques, such as, for example, employing URLs or Uniform Resource Indicators (URIs). URIs are similar to URLs, however, URIs typically indicate the source of files or actions, such as, for example, executables, scripts, and the like. Therefore, according to the one embodiment, the user system 105, the certificate authority 115, the vendor system 120, and the components of the trust engine 210, advantageously include sufficient data within

communication URLs or URIs for the transaction engine 205 to properly route data throughout the cryptographic system.

[0080] Although the data routing is disclosed with reference to its preferred embodiment, a skilled artisan will recognize a wide number of possible data routing solutions or strategies. For example, XML or other data packets may advantageously be unpacked and recognized by their format, content, or the like, such that the transaction engine 205 may properly route data throughout the trust engine 110. Moreover, a skilled artisan will recognize that the data routing may advantageously be adapted to the data transfer protocols conforming to particular network systems, such as, for example, when the communication link 125 comprises a local network.

[0081] According to yet another embodiment of the invention, the transaction engine 205 includes conventional SSL encryption technologies, such that the foregoing systems may authenticate themselves, and vice versa, with transaction engine 205, during particular communications. As will be used throughout this disclosure, the term "½ SSL" refers to communications where a server but not necessarily the client, is SSL authenticated, and the term "FULL SSL" refers to communications where the client and the server are SSL authenticated. When the instant disclosure uses the term "SSL", the communication may comprise ½ or FULL SSL.

[0082] As the transaction engine 205 routes data to the various components of the cryptographic system 100, the transaction engine 205 may advantageously create an audit trail. According to one embodiment, the audit trail includes a record of at least the type and format of data routed by the transaction engine 205 throughout the cryptographic system 100. Such audit data may advantageously be stored in the mass storage 225.

[0083] FIGURE 2 also illustrates the depository 210. According to one embodiment, the depository 210 comprises one or more data storage facilities, such as, for example, a directory server, a database server, or the like. As shown in FIGURE 2, the depository 210 stores cryptographic keys and enrollment authentication data. The cryptographic keys may advantageously correspond to the trust engine 110 or to users of the cryptographic system 100, such as the user or vendor. The enrollment authentication data may advantageously include data designed to uniquely identify a user, such as, user ID, passwords, answers to questions, biometric data, or the like. This enrollment authentication data may advantageously be acquired at enrollment of a user or another alternative later time. For example, the trust engine 110 may include periodic or other renewal or reissue of enrollment authentication data.

[0084] According to one embodiment, the communication from the transaction engine 205 to and from the authentication engine 215 and the cryptographic engine 220 comprises secure communication, such as, for example conventional SSL technology. In addition, as mentioned in the foregoing, the data of the communications to and from the depository 210 may be transferred using URLs, URIs, HTTP or XML documents, with any of the foregoing advantageously having data requests and formats embedded therein.

[0085] As mentioned above, the depository 210 may advantageously comprises a plurality of secure data storage facilities. In such an embodiment, the secure data storage facilities may be configured such that a compromise of the security in one individual data storage facility will not compromise the cryptographic keys or the authentication data stored therein. For example, according to this embodiment, the cryptographic keys and the authentication data are mathematically operated on so as to statistically and substantially randomize the data stored in each data storage facility. According to one embodiment, the randomization of the data of an individual data storage facility renders that data undecipherable. Thus, compromise of an individual data storage facility produces only a randomized undecipherable number and does not compromise the security of any cryptographic keys or the authentication data as a whole.

[0086] FIGURE 2 also illustrates the trust engine 110 including the authentication engine 215. According to one embodiment, the authentication engine 215 comprises a data comparator configured to compare data from the transaction engine 205 with data from the depository 210. For example, during authentication, a user supplies current authentication data to the trust engine 110 such that the transaction engine 205 receives the current authentication data. As mentioned in the foregoing, the transaction engine 205 recognizes the data requests, preferably in the URL or URI, and routes the authentication data to the authentication engine 215. Moreover, upon request, the depository 210 forwards enrollment authentication data corresponding to the user to the authentication engine 215. Thus, the authentication engine 215 has both the current authentication data and the enrollment authentication data for comparison.

[0087] According to one embodiment, the communications to the authentication engine comprise secure communications, such as, for example, SSL technology. Additionally, security can be provided within the trust engine 110 components, such as, for example, super-encryption using public key technologies. For example, according to one embodiment, the user encrypts the current authentication data with the public key of the authentication engine 215. In addition, the depository 210 also encrypts the enrollment authentication data

with the public key of the authentication engine 215. In this way, only the authentication engine's private key can be used to decrypt the transmissions.

[0088] As shown in FIGURE 2, the trust engine 110 also includes the cryptographic engine 220. According to one embodiment, the cryptographic engine comprises a cryptographic handling module, configured to advantageously provide conventional cryptographic functions, such as, for example, public-key infrastructure (PKI) functionality. For example, the cryptographic engine 220 may advantageously issue public and private keys for users of the cryptographic system 100. In this manner, the cryptographic keys are generated at the cryptographic engine 220 and forwarded to the depository 210 such that at least the private cryptographic keys are not available outside of the trust engine 110. According to another embodiment, the cryptographic engine 220 randomizes and splits at least the private cryptographic key data, thereby storing only the randomized split data. Similar to the splitting of the enrollment authentication data, the splitting process ensures the stored keys are not available outside the cryptographic engine 220. According to another embodiment, the functions of the cryptographic engine can be combined with and performed by the authentication engine 215.

[0089] According to one embodiment, communications to and from the cryptographic engine include secure communications, such as SSL technology. In addition, XML documents may advantageously be employed to transfer data and/or make cryptographic function requests.

[0090] FIGURE 2 also illustrates the trust engine 110 having the mass storage 225. As mentioned in the foregoing, the transaction engine 205 keeps data corresponding to an audit trail and stores such data in the mass storage 225. Similarly, according to one embodiment of the invention, the depository 210 keeps data corresponding to an audit trail and stores such data in the mass storage device 225. The depository audit trail data is similar to that of the transaction engine 205 in that the audit trail data comprises a record of the requests received by the depository 210 and the response thereof. In addition, the mass storage 225 may be used to store digital certificates having the public key of a user contained therein.

[0091] Although the trust engine 110 is disclosed with reference to its preferred and alternative embodiments, the invention is not intended to be limited thereby. Rather, a skilled artisan will recognize in the disclosure herein, a wide number of alternatives for the trust engine 110. For example, the trust engine 110, may advantageously perform only authentication, or alternatively, only some or all of the cryptographic functions, such as data encryption and decryption. According to such embodiments, one of the authentication

engine 215 and the cryptographic engine 220 may advantageously be removed, thereby creating a more straightforward design for the trust engine 110. In addition, the cryptographic engine 220 may also communicate with a certificate authority such that the certificate authority is embodied within the trust engine 110. According to yet another embodiment, the trust engine 110 may advantageously perform authentication and one or more cryptographic functions, such as, for example, digital signing.

[0092] FIGURE 3 illustrates a block diagram of the transaction engine 205 of FIGURE 2, according to aspects of an embodiment of the invention. According to this embodiment, the transaction engine 205 comprises an operating system 305 having a handling thread and a listening thread. The operating system 305 may advantageously be similar to those found in conventional high volume servers, such as, for example, Web servers available from Apache. The listening thread monitors the incoming communication from one of the communication link 125, the authentication engine 215, and the cryptographic engine 220 for incoming data flow. The handling thread recognizes particular data structures of the incoming data flow, such as, for example, the foregoing data structures, thereby routing the incoming data to one of the communication link 125, the depository 210, the authentication engine 215, the cryptographic engine 220, or the mass storage 225. As shown in FIGURE 3, the incoming and outgoing data may advantageously be secured through, for example, SSL technology.

[0093] FIGURE 4 illustrates a block diagram of the depository 210 of FIGURE 2 according to aspects of an embodiment of the invention. According to this embodiment, the depository 210 comprises one or more lightweight directory access protocol (LDAP) servers. LDAP directory servers are available from a wide variety of manufacturers such as Netscape, ISO, and others. FIGURE 4 also shows that the directory server preferably stores data 405 corresponding to the cryptographic keys and data 410 corresponding to the enrollment authentication data. According to one embodiment, the depository 210 comprises a single logical memory structure indexing authentication data and cryptographic key data to a unique user ID. The single logical memory structure preferably includes mechanisms to ensure a high degree of trust, or security, in the data stored therein. For example, the physical location of the depository 210 may advantageously include a wide number of conventional security measures, such as limited employee access, modern surveillance systems, and the like. In addition to, or in lieu of, the physical securities, the computer system or server may advantageously include software solutions to protect the stored data. For example, the depository 210 may advantageously create and store data 415 corresponding to an audit trail of actions taken. In addition, the incoming and outgoing communications may

advantageously be encrypted with public key encryption coupled with conventional SSL technologies.

[0094] According to another embodiment, the depository 210 may comprise distinct and physically separated data storage facilities, as disclosed further with reference to FIGURE 7.

[0095] FIGURE 5 illustrates a block diagram of the authentication engine 215 of FIGURE 2 according to aspects of an embodiment of the invention. Similar to the transaction engine 205 of FIGURE 3, the authentication engine 215 comprises an operating system 505 having at least a listening and a handling thread of a modified version of a conventional Web server, such as, for example, Web servers available from Apache. As shown in FIGURE 5, the authentication engine 215 includes access to at least one private key 510. The private key 510 may advantageously be used for example, to decrypt data from the transaction engine 205 or the depository 210, which was encrypted with a corresponding public key of the authentication engine 215.

[0096] FIGURE 5 also illustrates the authentication engine 215 comprising a comparator 515, a data splitting module 520, and a data assembling module 525. According to the preferred embodiment of the invention, the comparator 515 includes technology capable of comparing potentially complex patterns related to the foregoing biometric authentication data. The technology may include hardware, software, or combined solutions for pattern comparisons, such as, for example, those representing finger print patterns or voice patterns. In addition, according to one embodiment, the comparator 515 of the authentication engine 215 may advantageously compare conventional hashes of documents in order to render a comparison result. According to one embodiment of the invention, the comparator 515 includes the application of heuristics 530 to the comparison. The heuristics 530 may advantageously address circumstances surrounding an authentication attempt, such as, for example, the time of day, IP address or subnet mask, purchasing profile, email address, processor serial number or ID, or the like.

[0097] Moreover, the nature of biometric data comparisons may result in varying degrees of confidence being produced from the matching of current biometric authentication data to enrollment data. For example, unlike a traditional password which may only return a positive or negative match, a fingerprint may be determined to be a partial match, e.g. a 90% match, a 75% match, or a 10% match, rather than simply being correct or incorrect. Other biometric identifiers such as voice print analysis or face recognition may share this property of probabilistic authentication, rather than absolute authentication.

[0098] When working with such probabilistic authentication or in other cases where an authentication is considered less than absolutely reliable, it is desirable to apply the heuristics 530 to determine whether the level of confidence in the authentication provided is sufficiently high to authenticate the transaction which is being made.

[0099] It will sometimes be the case that the transaction at issue is a relatively low value transaction where it is acceptable to be authenticated to a lower level of confidence. This could include a transaction which has a low dollar value associated with it (e.g., a \$10 purchase) or a transaction with low risk (e.g., admission to a members-only web site).

[0100] Conversely, for authenticating other transactions, it may be desirable to require a high degree of confidence in the authentication before allowing the transaction to proceed. Such transactions may include transactions of large dollar value (e.g., signing a multi-million dollar supply contract) or transaction with a high risk if an improper authentication occurs (e.g., remotely logging onto a government computer).

[0101] The use of the heuristics 530 in combination with confidence levels and transactions values may be used as will be described below to allow the comparator to provide a dynamic context-sensitive authentication system.

[0102] According to another embodiment of the invention, the comparator 515 may advantageously track authentication attempts for a particular transaction. For example, when a transaction fails, the trust engine 110 may request the user to re-enter his or her current authentication data. The comparator 515 of the authentication engine 215 may advantageously employ an attempt limiter 535 to limit the number of authentication attempts, thereby prohibiting brute-force attempts to impersonate a user's authentication data. According to one embodiment, the attempt limiter 535 comprises a software module monitoring transactions for repeating authentication attempts and, for example, limiting the authentication attempts for a given transaction to three. Thus, the attempt limiter 535 will limit an automated attempt to impersonate an individual's authentication data to, for example, simply three "guesses." Upon three failures, the attempt limiter 535 may advantageously deny additional authentication attempts. Such denial may advantageously be implemented through, for example, the comparator 515 returning a negative result regardless of the current authentication data being transmitted. On the other hand, the transaction engine 205 may advantageously block any additional authentication attempts pertaining to a transaction in which three attempts have previously failed.

[0103] The authentication engine 215 also includes the data splitting module 520 and the data assembling module 525. The data splitting module 520 advantageously comprises a

software, hardware, or combination module having the ability to mathematically operate on various data so as to substantially randomize and split the data into portions. According to one embodiment, original data is not recreatable from an individual portion. The data assembling module 525 advantageously comprises a software, hardware, or combination module configured to mathematically operate on the foregoing substantially randomized portions, such that the combination thereof provides the original deciphered data. According to one embodiment, the authentication engine 215 employs the data splitting module 520 to randomize and split enrollment authentication data into portions, and employs the data assembling module 525 to reassemble the portions into usable enrollment authentication data. **[0104]** FIGURE 6 illustrates a block diagram of the cryptographic engine 220 of the trust engine 200 of FIGURE 2 according to aspects of one embodiment of the invention. Similar to the transaction engine 205 of FIGURE 3, the cryptographic engine 220 comprises an operating system 605 having at least a listening and a handling thread of a modified version of a conventional Web server, such as, for example, Web servers available from Apache. As shown in FIGURE 6, the cryptographic engine 220 comprises a data splitting module 610 and a data assembling module 620 that function similar to those of FIGURE 5. However, according to one embodiment, the data splitting module 610 and the data assembling module 620 process cryptographic key data, as opposed to the foregoing enrollment authentication data. Although, a skilled artisan will recognize from the disclosure herein that the data splitting module 910 and the data splitting module 620 may be combined with those of the authentication engine 215.

[0105] The cryptographic engine 220 also comprises a cryptographic handling module 625 configured to perform one, some or all of a wide number of cryptographic functions. According to one embodiment, the cryptographic handling module 625 may comprise software modules or programs, hardware, or both. According to another embodiment, the cryptographic handling module 625 may perform data comparisons, data parsing, data splitting, data separating, data hashing, data encryption or decryption, digital signature verification or creation, digital certificate generation, storage, or requests, cryptographic key generation, or the like. Moreover, a skilled artisan will recognize from the disclosure herein that the cryptographic handling module 825 may advantageously comprises a public-key infrastructure, such as Pretty Good Privacy (PGP), an RSA-based public-key system, or a wide number of alternative key management systems. In addition, the cryptographic handling module 625 may perform public-key encryption, symmetric-key encryption, or both. In addition to the foregoing, the cryptographic handling module 625 may include one or more

computer programs or modules, hardware, or both, for implementing seamless, transparent, interoperability functions.

[0106] A skilled artisan will also recognize from the disclosure herein that the cryptographic functionality may include a wide number or variety of functions generally relating to cryptographic key management systems.

[0107] FIGURE 7 illustrates a simplified block diagram of a depository system 700 according to aspects of an embodiment of the invention. As shown in FIGURE 7, the depository system 700 advantageously comprises multiple data storage facilities, for example, data storage facilities D1, D2, D3, and D4. However, it is readily understood by those of ordinary skill in the art that the depository system may have only one data storage facility. According to one embodiment of the invention, each of the data storage facilities D1 through D4 may advantageously comprise some or all of the elements disclosed with reference to the depository 210 of FIGURE 4. Similar to the depository 210, the data storage facilities D1 through D4 communicate with the transaction engine 205, the authentication engine 215, and the cryptographic engine 220, preferably through conventional SSL. Communication links transferring, for example, XML documents. Communications from the transaction engine 205 may advantageously include requests for data, wherein the request is advantageously broadcast to the IP address of each data storage facility D1 through D4. On the other hand, the transaction engine 205 may broadcast requests to particular data storage facilities based on a wide number of criteria, such as, for example, response time, server loads, maintenance schedules, or the like.

[0108] In response to requests for data from the transaction engine 205, the depository system 700 advantageously forwards stored data to the authentication engine 215 and the cryptographic engine 220. The respective data assembling modules receive the forwarded data and assemble the data into useable formats. On the other hand, communications from the authentication engine 215 and the cryptographic engine 220 to the data storage facilities D1 through D4 may include the transmission of sensitive data to be stored. For example, according to one embodiment, the authentication engine 215 and the cryptographic engine 220 may advantageously employ their respective data splitting modules to divide sensitive data into undecipherable portions, and then transmit one or more undecipherable portions of the sensitive data to a particular data storage facility.

[0109] According to one embodiment, each data storage facility, D1 through D4, comprises a separate and independent storage system, such as, for example, a directory server. According to another embodiment of the invention, the depository system 700 comprises

multiple geographically separated independent data storage systems. By distributing the sensitive data into distinct and independent storage facilities D1 through D4, some or all of which may be advantageously geographically separated, the depository system 700 provides redundancy along with additional security measures. For example, according to one embodiment, only data from two of the multiple data storage facilities, D1 through D4, are needed to decipher and reassemble the sensitive data. Thus, as many as two of the four data storage facilities D1 through D4 may be inoperative due to maintenance, system failure, power failure, or the like, without affecting the functionality of the trust engine 110. In addition, because, according to one embodiment, the data stored in each data storage facility is randomized and undecipherable, compromise of any individual data storage facility does not necessarily compromise the sensitive data. Moreover, in the embodiment having geographical separation of the data storage facilities, a compromise of multiple geographically remote facilities becomes increasingly difficult. In fact, even a rogue employee will be greatly challenged to subvert the needed multiple independent geographically remote data storage facilities.

[0110] Although the depository system 700 is disclosed with reference to its preferred and alternative embodiments, the invention is not intended to be limited thereby. Rather, a skilled artisan will recognize from the disclosure herein, a wide number of alternatives for the depository system 700. For example, the depository system 700 may comprise one, two or more data storage facilities. In addition, sensitive data may be mathematically operated such that portions from two or more data storage facilities are needed to reassemble and decipher the sensitive data.

[0111] As mentioned in the foregoing, the authentication engine 215 and the cryptographic engine 220 each include a data splitting module 520 and 610, respectively, for splitting any type or form of sensitive data, such as, for example, text, audio, video, the authentication data and the cryptographic key data. FIGURE 8 illustrates a flowchart of a data splitting process 800 performed by the data splitting module according to aspects of an embodiment of the invention. As shown in FIGURE 8, the data splitting process 800 begins at step 805 when sensitive data "S" is received by the data splitting module of the authentication engine 215 or the cryptographic engine 220. Preferably, in step 810, the data splitting module then generates a substantially random number, value, or string or set of bits, "A." For example, the random number A may be generated in a wide number of varying conventional techniques available to one of ordinary skill in the art, for producing high quality random numbers suitable for use in cryptographic applications. In addition, according to one embodiment, the

random number A comprises a bit length which may be any suitable length, such as shorter, longer or equal to the bit length of the sensitive data, S.

[0112] In addition, in step 820 the data splitting process 800 generates another statistically random number "C." According to the preferred embodiment, the generation of the statistically random numbers A and C may advantageously be done in parallel. The data splitting module then combines the numbers A and C with the sensitive data S such that new numbers "B" and "D" are generated. For example, number B may comprise the binary combination of A XOR S and number D may comprise the binary combination of C XOR S. The XOR function, or the "exclusive-or" function, is well known to those of ordinary skill in the art. The foregoing combinations preferably occur in steps 825 and 830, respectively, and, according to one embodiment, the foregoing combinations also occur in parallel. The data splitting process 800 then proceeds to step 835 where the random numbers A and C and the numbers B and D are paired such that none of the pairings contain sufficient data, by themselves, to reorganize and decipher the original sensitive data S. For example, the numbers may be paired as follows: AC, AD, BC, and BD. According to one embodiment, each of the foregoing pairings is distributed to one of the depositories D1 through D4 of FIGURE 7. According to another embodiment, each of the foregoing pairings is randomly distributed to one of the depositories D1 through D4. For example, during a first data splitting process 800, the pairing AC may be sent to depository D2, through, for example, a random selection of D2's IP address. Then, during a second data splitting process 800, the pairing AC may be sent to depository D4, through, for example, a random selection of D4's IP address. In addition, the pairings may all be stored on one depository, and may be stored in separate locations on said depository.

[0113] Based on the foregoing, the data splitting process 800 advantageously places portions of the sensitive data in each of the four data storage facilities D1 through D4, such that no single data storage facility D1 through D4 includes sufficient encrypted data to recreate the original sensitive data S. As mentioned in the foregoing, such randomization of the data into individually unusable encrypted portions increases security and provides for maintained trust in the data even if one of the data storage facilities, D1 through D4, is compromised.

[0114] Although the data splitting process 800 is disclosed with reference to its preferred embodiment, the invention is not intended to be limited thereby. Rather a skilled artisan will recognize from the disclosure herein, a wide number of alternatives for the data splitting process 800. For example, the data splitting process may advantageously split the data into

two numbers, for example, random number A and number B and, randomly distribute A and B through two data storage facilities. Moreover, the data splitting process 800 may advantageously split the data among a wide number of data storage facilities through generation of additional random numbers. The data may be split into any desired, selected, predetermined, or randomly assigned size unit, including but not limited to, a bit, bits, bytes, kilobytes, megabytes or larger, or any combination or sequence of sizes. In addition, varying the sizes of the data units resulting from the splitting process may render the data more difficult to restore to a useable form, thereby increasing security of sensitive data. It is readily apparent to those of ordinary skill in the art that the split data unit sizes may be a wide variety of data unit sizes or patterns of sizes or combinations of sizes. For example, the data unit sizes may be selected or predetermined to be all of the same size, a fixed set of different sizes, a combination of sizes, or randomly generates sizes. Similarly, the data units may be distributed into one or more shares according to a fixed or predetermined data unit size, a pattern or combination of data unit sizes, or a randomly generated data unit size or sizes per share.

[0115] As mentioned in the foregoing, in order to recreate the sensitive data S, the data portions need to be derandomized and reorganized. This process may advantageously occur in the data assembling modules, 525 and 620, of the authentication engine 215 and the cryptographic engine 220, respectively. The data assembling module, for example, data assembly module 525, receives data portions from the data storage facilities D1 through D4, and reassembles the data into useable form. For example, according to one embodiment where the data splitting module 520 employed the data splitting process 800 of FIGURE 8, the data assembling module 525 uses data portions from at least two of the data storage facilities D1 through D4 to recreate the sensitive data S. For example, the pairings of AC, AD, BC, and BD, were distributed such that any two provide one of A and B, or, C and D. Noting that $S = A \text{ XOR } B$ or $S = C \text{ XOR } D$ indicates that when the data assembling module receives one of A and B, or, C and D, the data assembling module 525 can advantageously reassemble the sensitive data S. Thus, the data assembling module 525 may assemble the sensitive data S, when, for example, it receives data portions from at least the first two of the data storage facilities D1 through D4 to respond to an assemble request by the trust engine 110.

[0116] Based on the above data splitting and assembling processes, the sensitive data S exists in usable format only in a limited area of the trust engine 110. For example, when the sensitive data S includes enrollment authentication data, usable, nonrandomized enrollment

authentication data is available only in the authentication engine 215. Likewise, when the sensitive data S includes private cryptographic key data, usable, nonrandomized private cryptographic key data is available only in the cryptographic engine 220.

[0117] Although the data splitting and assembling processes are disclosed with reference to their preferred embodiments, the invention is not intended to be limited thereby. Rather, a skilled artisan will recognize from the disclosure herein, a wide number of alternatives for splitting and reassembling the sensitive data S. For example, public-key encryption may be used to further secure the data at the data storage facilities D1 through D4. In addition, it is readily apparent to those of ordinary skill in the art that the data splitting module described herein is also a separate and distinct embodiment of the present invention that may be incorporated into, combined with or otherwise made part of any pre-existing computer systems, software suites, database, or combinations thereof, or other embodiments of the present invention, such as the trust engine, authentication engine, and transaction engine disclosed and described herein.

[0118] FIGURE 9A illustrates a data flow of an enrollment process 900 according to aspects of an embodiment of the invention. As shown in FIGURE 9A, the enrollment process 900 begins at step 905 when a user desires to enroll with the trust engine 110 of the cryptographic system 100. According to this embodiment, the user system 105 advantageously includes a client-side applet, such as a Java-based, that queries the user to enter enrollment data, such as demographic data and enrollment authentication data. According to one embodiment, the enrollment authentication data includes user ID, password(s), biometric(s), or the like. According to one embodiment, during the querying process, the client-side applet preferably communicates with the trust engine 110 to ensure that a chosen user ID is unique. When the user ID is nonunique, the trust engine 110 may advantageously suggest a unique user ID. The client-side applet gathers the enrollment data and transmits the enrollment data, for example, through an XML document, to the trust engine 110, and in particular, to the transaction engine 205. According to one embodiment, the transmission is encoded with the public key of the authentication engine 215.

[0119] According to one embodiment, the user performs a single enrollment during step 905 of the enrollment process 900. For example, the user enrolls himself or herself as a particular person, such as Joe User. When Joe User desires to enroll as Joe User, CEO of Mega Corp., then according to this embodiment, Joe User enrolls a second time, receives a second unique user ID and the trust engine 110 does not associate the two identities. According to another embodiment of the invention, the enrollment process 900 provides for multiple user identities

for a single user ID. Thus, in the above example, the trust engine 110 will advantageously associate the two identities of Joe User. As will be understood by a skilled artisan from the disclosure herein, a user may have many identities, for example, Joe User the head of household, Joe User the member of the Charitable Foundations, and the like. Even though the user may have multiple identities, according to this embodiment, the trust engine 110 preferably stores only one set of enrollment data. Moreover, users may advantageously add, edit/update, or delete identities as they are needed.

[0120] Although the enrollment process 900 is disclosed with reference to its preferred embodiment, the invention is not intended to be limited thereby. Rather, a skilled artisan will recognize from the disclosure herein, a wide number of alternatives for gathering of enrollment data, and in particular, enrollment authentication data. For example, the applet may be common object model (COM) based applet or the like.

[0121] On the other hand, the enrollment process may include graded enrollment. For example, at a lowest level of enrollment, the user may enroll over the communication link 125 without producing documentation as to his or her identity. According to an increased level of enrollment, the user enrolls using a trusted third party, such as a digital notary. For example, and the user may appear in person to the trusted third party, produce credentials such as a birth certificate, driver's license, military ID, or the like, and the trusted third party may advantageously include, for example, their digital signature in enrollment submission. The trusted third party may include an actual notary, a government agency, such as the Post Office or Department of Motor Vehicles, a human resources person in a large company enrolling an employee, or the like. A skilled artisan will understand from the disclosure herein that a wide number of varying levels of enrollment may occur during the enrollment process 900.

[0122] After receiving the enrollment authentication data, at step 915, the transaction engine 205, using conventional FULL SSL technology forwards the enrollment authentication data to the authentication engine 215. In step 920, the authentication engine 215 decrypts the enrollment authentication data using the private key of the authentication engine 215. In addition, the authentication engine 215 employs the data splitting module to mathematically operate on the enrollment authentication data so as to split the data into at least two independently undecipherable, randomized, numbers. As mentioned in the foregoing, at least two numbers may comprise a statistically random number and a binary XORed number. In step 925, the authentication engine 215 forwards each portion of the randomized numbers to one of the data storage facilities D1 through D4. As mentioned in the foregoing, the

authentication engine 215 may also advantageously randomize which portions are transferred to which depositories.

[0123] Often during the enrollment process 900, the user will also desire to have a digital certificate issued such that he or she may receive encrypted documents from others outside the cryptographic system 100. As mentioned in the foregoing, the certificate authority 115 generally issues digital certificates according to one or more of several conventional standards. Generally, the digital certificate includes a public key of the user or system, which is known to everyone.

[0124] Whether the user requests a digital certificate at enrollment, or at another time, the request is transferred through the trust engine 110 to the authentication engine 215.

According to one embodiment, the request includes an XML document having, for example, the proper name of the user. According to step 935, the authentication engine 215 transfers the request to the cryptographic engine 220 instructing the cryptographic engine 220 to generate a cryptographic key or key pair.

[0125] Upon request, at step 935, the cryptographic engine 220 generates at least one cryptographic key. According to one embodiment, the cryptographic handling module 625 generates a key pair, where one key is used as a private key, and one is used as a public key. The cryptographic engine 220 stores the private key and, according to one embodiment, a copy of the public key. In step 945, the cryptographic engine 220 transmits a request for a digital certificate to the transaction engine 205. According to one embodiment, the request advantageously includes a standardized request, such as PKCS10, embedded in, for example, an XML document. The request for a digital certificate may advantageously correspond to one or more certificate authorities and the one or more standard formats the certificate authorities require.

[0126] In step 950 the transaction engine 205 forwards this request to the certificate authority 115, who, in step 955, returns a digital certificate. The return digital certificate may advantageously be in a standardized format, such as PKCS7, or in a proprietary format of one or more of the certificate authorities 115. In step 960, the digital certificate is received by the transaction engine 205, and a copy is forwarded to the user and a copy is stored with the trust engine 110. The trust engine 110 stores a copy of the certificate such that the trust engine 110 will not need to rely on the availability of the certificate authority 115. For example, when the user desires to send a digital certificate, or a third party requests the user's digital certificate, the request for the digital certificate is typically sent to the certificate

authority 115. However, if the certificate authority 115 is conducting maintenance or has been victim of a failure or security compromise, the digital certificate may not be available.

[0127] At any time after issuing the cryptographic keys, the cryptographic engine 220 may advantageously employ the data splitting process 800 described above such that the cryptographic keys are split into independently undecipherable randomized numbers. Similar to the authentication data, at step 965 the cryptographic engine 220 transfers the randomized numbers to the data storage facilities D1 through D4.

[0128] A skilled artisan will recognize from the disclosure herein that the user may request a digital certificate anytime after enrollment. Moreover, the communications between systems may advantageously include FULL SSL or public-key encryption technologies. Moreover, the enrollment process may issue multiple digital certificates from multiple certificate authorities, including one or more proprietary certificate authorities internal or external to the trust engine 110.

[0129] As disclosed in steps 935 through 960, one embodiment of the invention includes the request for a certificate that is eventually stored on the trust engine 110. Because, according to one embodiment, the cryptographic handling module 625 issues the keys used by the trust engine 110, each certificate corresponds to a private key. Therefore, the trust engine 110 may advantageously provide for interoperability through monitoring the certificates owned by, or associated with, a user. For example, when the cryptographic engine 220 receives a request for a cryptographic function, the cryptographic handling module 625 may investigate the certificates owned by the requesting user to determine whether the user owns a private key matching the attributes of the request. When such a certificate exists, the cryptographic handling module 625 may use the certificate or the public or private keys associated therewith, to perform the requested function. When such a certificate does not exist, the cryptographic handling module 625 may advantageously and transparently perform a number of actions to attempt to remedy the lack of an appropriate key. For example, FIGURE 9B illustrates a flowchart of an interoperability process 970, which according to aspects of an embodiment of the invention, discloses the foregoing steps to ensure the cryptographic handling module 625 performs cryptographic functions using appropriate keys.

[0130] As shown in FIGURE 9B, the interoperability process 970 begins with step 972 where the cryptographic handling module 925 determines the type of certificate desired. According to one embodiment of the invention, the type of certificate may advantageously be specified in the request for cryptographic functions, or other data provided by the requestor. According to another embodiment, the certificate type may be ascertained by the data format

of the request. For example, the cryptographic handling module 925 may advantageously recognize the request corresponds to a particular type.

[0131] According to one embodiment, the certificate type may include one or more algorithm standards, for example, RSA, ELGAMAL, or the like. In addition, the certificate type may include one or more key types, such as symmetric keys, public keys, strong encryption keys such as 256 bit keys, less secure keys, or the like. Moreover, the certificate type may include upgrades or replacements of one or more of the foregoing algorithm standards or keys, one or more message or data formats, one or more data encapsulation or encoding schemes, such as Base 32 or Base 64. The certificate type may also include compatibility with one or more third-party cryptographic applications or interfaces, one or more communication protocols, or one or more certificate standards or protocols. A skilled artisan will recognize from the disclosure herein that other differences may exist in certificate types, and translations to and from those differences may be implemented as disclosed herein.

[0132] Once the cryptographic handling module 625 determines the certificate type, the interoperability process 970 proceeds to step 974, and determines whether the user owns a certificate matching the type determined in step 974. When the user owns a matching certificate, for example, the trust engine 110 has access to the matching certificate through, for example, prior storage thereof, the cryptographic handling module 825 knows that a matching private key is also stored within the trust engine 110. For example, the matching private key may be stored within the depository 210 or depository system 700. The cryptographic handling module 625 may advantageously request the matching private key be assembled from, for example, the depository 210, and then in step 976, use the matching private key to perform cryptographic actions or functions. For example, as mentioned in the foregoing, the cryptographic handling module 625 may advantageously perform hashing, hash comparisons, data encryption or decryption, digital signature verification or creation, or the like.

[0133] When the user does not own a matching certificate, the interoperability process 970 proceeds to step 978 where the cryptographic handling module 625 determines whether the users owns a cross-certified certificate. According to one embodiment, cross-certification between certificate authorities occurs when a first certificate authority determines to trust certificates from a second certificate authority. In other words, the first certificate authority determines that certificates from the second certificate authority meets certain quality standards, and therefore, may be "certified" as equivalent to the first certificate authority's own certificates. Cross-certification becomes more complex when the certificate authorities

issue, for example, certificates having levels of trust. For example, the first certificate authority may provide three levels of trust for a particular certificate, usually based on the degree of reliability in the enrollment process, while the second certificate authority may provide seven levels of trust. Cross-certification may advantageously track which levels and which certificates from the second certificate authority may be substituted for which levels and which certificates from the first. When the foregoing cross-certification is done officially and publicly between two certification authorities, the mapping of certificates and levels to one another is often called "chaining."

[0134] According to another embodiment of the invention, the cryptographic handling module 625 may advantageously develop cross-certifications outside those agreed upon by the certificate authorities. For example, the cryptographic handling module 625 may access a first certificate authority's certificate practice statement (CPS), or other published policy statement, and using, for example, the authentication tokens required by particular trust levels, match the first certificate authority's certificates to those of another certificate authority.

[0135] When, in step 978, the cryptographic handling module 625 determines that the users owns a cross-certified certificate, the interoperability process 970 proceeds to step 976, and performs the cryptographic action or function using the cross-certified public key, private key, or both. Alternatively, when the cryptographic handling module 625 determines that the users does not own a cross-certified certificate, the interoperability process 970 proceeds to step 980, where the cryptographic handling module 625 selects a certificate authority that issues the requested certificate type, or a certificate cross-certified thereto. In step 982, the cryptographic handling module 625 determines whether the user enrollment authentication data, discussed in the foregoing, meets the authentication requirements of the chosen certificate authority. For example, if the user enrolled over a network by, for example, answering demographic and other questions, the authentication data provided may establish a lower level of trust than a user providing biometric data and appearing before a third-party, such as, for example, a notary. According to one embodiment, the foregoing authentication requirements may advantageously be provided in the chosen authentication authority's CPS.

[0136] When the user has provided the trust engine 110 with enrollment authentication data meeting the requirements of chosen certificate authority, the interoperability process 970 proceeds to step 984, where the cryptographic handling module 825 acquires the certificate from the chosen certificate authority. According to one embodiment, the cryptographic handling module 625 acquires the certificate by following steps 945 through 960 of the enrollment process 900. For example, the cryptographic handling module 625 may

advantageously employ one or more public keys from one or more of the key pairs already available to the cryptographic engine 220, to request the certificate from the certificate authority. According to another embodiment, the cryptographic handling module 625 may advantageously generate one or more new key pairs, and use the public keys corresponding thereto, to request the certificate from the certificate authority.

[0137] According to another embodiment, the trust engine 110 may advantageously include one or more certificate issuing modules capable of issuing one or more certificate types. According to this embodiment, the certificate issuing module may provide the foregoing certificate. When the cryptographic handling module 625 acquires the certificate, the interoperability process 970 proceeds to step 976, and performs the cryptographic action or function using the public key, private key, or both corresponding to the acquired certificate.

[0138] When the user, in step 982, has not provided the trust engine 110 with enrollment authentication data meeting the requirements of chosen certificate authority, the cryptographic handling module 625 determines, in step 986 whether there are other certificate authorities that have different authentication requirements. For example, the cryptographic handling module 625 may look for certificate authorities having lower authentication requirements, but still issue the chosen certificates, or cross-certifications thereof.

[0139] When the foregoing certificate authority having lower requirements exists, the interoperability process 970 proceeds to step 980 and chooses that certificate authority. Alternatively, when no such certificate authority exists, in step 988, the trust engine 110 may request additional authentication tokens from the user. For example, the trust engine 110 may request new enrollment authentication data comprising, for example, biometric data. Also, the trust engine 110 may request the user appear before a trusted third party and provide appropriate authenticating credentials, such as, for example, appearing before a notary with a drivers license, social security card, bank card, birth certificate, military ID, or the like. When the trust engine 110 receives updated authentication data, the interoperability process 970 proceeds to step 984 and acquires the foregoing chosen certificate.

[0140] Through the foregoing interoperability process 970, the cryptographic handling module 625 advantageously provides seamless, transparent, translations and conversions between differing cryptographic systems. A skilled artisan will recognize from the disclosure herein, a wide number of advantages and implementations of the foregoing interoperable system. For example, the foregoing step 986 of the interoperability process 970 may advantageously include aspects of trust arbitrage, discussed in further detail below, where the certificate authority may under special circumstances accept lower levels of

cross-certification. In addition, the interoperability process 970 may include ensuring interoperability between and employment of standard certificate revocations, such as employing certificate revocation lists (CRL), online certificate status protocols (OCSP), or the like.

[0141] FIGURE 10 illustrates a data flow of an authentication process 1000 according to aspects of an embodiment of the invention. According to one embodiment, the authentication process 1000 includes gathering current authentication data from a user and comparing that to the enrollment authentication data of the user. For example, the authentication process 1000 begins at step 1005 where a user desires to perform a transaction with, for example, a vendor. Such transactions may include, for example, selecting a purchase option, requesting access to a restricted area or device of the vendor system 120, or the like. At step 1010, a vendor provides the user with a transaction ID and an authentication request. The transaction ID may advantageously include a 192 bit quantity having a 32 bit timestamp concatenated with a 128 bit random quantity, or a "nonce," concatenated with a 32 bit vendor specific constant. Such a transaction ID uniquely identifies the transaction such that copycat transactions can be refused by the trust engine 110.

[0142] The authentication request may advantageously include what level of authentication is needed for a particular transaction. For example, the vendor may specify a particular level of confidence that is required for the transaction at issue. If authentication cannot be made to this level of confidence, as will be discussed below, the transaction will not occur without either further authentication by the user to raise the level of confidence, or a change in the terms of the authentication between the vendor and the server. These issues are discussed more completely below.

[0143] According to one embodiment, the transaction ID and the authentication request may be advantageously generated by a vendor-side applet or other software program. In addition, the transmission of the transaction ID and authentication data may include one or more XML documents encrypted using conventional SSL technology, such as, for example, $\frac{1}{2}$ SSL, or, in other words vendor-side authenticated SSL.

[0144] After the user system 105 receives the transaction ID and authentication request, the user system 105 gathers the current authentication data, potentially including current biometric information, from the user. The user system 105, at step 1015, encrypts at least the current authentication data "B" and the transaction ID, with the public key of the authentication engine 215, and transfers that data to the trust engine 110. The transmission preferably comprises XML documents encrypted with at least conventional $\frac{1}{2}$ SSL

technology. In step 1020, the transaction engine 205 receives the transmission, preferably recognizes the data format or request in the URL or URI, and forwards the transmission to the authentication engine 215.

[0145] During steps 1015 and 1020, the vendor system 120, at step 1025, forwards the transaction ID and the authentication request to the trust engine 110, using the preferred FULL SSL technology. This communication may also include a vendor ID, although vendor identification may also be communicated through a non-random portion of the transaction ID. At steps 1030 and 1035, the transaction engine 205 receives the communication, creates a record in the audit trail, and generates a request for the user's enrollment authentication data to be assembled from the data storage facilities D1 through D4. At step 1040, the depository system 700 transfers the portions of the enrollment authentication data corresponding to the user to the authentication engine 215. At step 1045, the authentication engine 215 decrypts the transmission using its private key and compares the enrollment authentication data to the current authentication data provided by the user.

[0146] The comparison of step 1045 may advantageously apply heuristical context sensitive authentication, as referred to in the forgoing, and discussed in further detail below. For example, if the biometric information received does not match perfectly, a lower confidence match results. In particular embodiments, the level of confidence of the authentication is balanced against the nature of the transaction and the desires of both the user and the vendor. Again, this is discussed in greater detail below.

[0147] At step 1050, the authentication engine 215 fills in the authentication request with the result of the comparison of step 1045. According to one embodiment of the invention, the authentication request is filled with a YES/NO or TRUE/FALSE result of the authentication process 1000. In step 1055 the filled-in authentication request is returned to the vendor for the vendor to act upon, for example, allowing the user to complete the transaction that initiated the authentication request. According to one embodiment, a confirmation message is passed to the user.

[0148] Based on the foregoing, the authentication process 1000 advantageously keeps sensitive data secure and produces results configured to maintain the integrity of the sensitive data. For example, the sensitive data is assembled only inside the authentication engine 215. For example, the enrollment authentication data is undecipherable until it is assembled in the authentication engine 215 by the data assembling module, and the current authentication data is undecipherable until it is unwrapped by the conventional SSL technology and the private key of the authentication engine 215. Moreover, the authentication result transmitted to the

vendor does not include the sensitive data, and the user may not even know whether he or she produced valid authentication data.

[0149] Although the authentication process 1000 is disclosed with reference to its preferred and alternative embodiments, the invention is not intended to be limited thereby. Rather, a skilled artisan will recognize from the disclosure herein, a wide number of alternatives for the authentication process 1000. For example, the vendor may advantageously be replaced by almost any requesting application, even those residing with the user system 105. For example, a client application, such as Microsoft Word, may use an application program interface (API) or a cryptographic API (CAPI) to request authentication before unlocking a document. Alternatively, a mail server, a network, a cellular phone, a personal or mobile computing device, a workstation, or the like, may all make authentication requests that can be filled by the authentication process 1000. In fact, after providing the foregoing trusted authentication process 1000, the requesting application or device may provide access to or use of a wide number of electronic or computer devices or systems.

[0150] Moreover, the authentication process 1000 may employ a wide number of alternative procedures in the event of authentication failure. For example, authentication failure may maintain the same transaction ID and request that the user reenter his or her current authentication data. As mentioned in the foregoing, use of the same transaction ID allows the comparator of the authentication engine 215 to monitor and limit the number of authentication attempts for a particular transaction, thereby creating a more secure cryptographic system 100.

[0151] In addition, the authentication process 1000 may be advantageously be employed to develop elegant single sign-on solutions, such as, unlocking a sensitive data vault. For example, successful or positive authentication may provide the authenticated user the ability to automatically access any number of passwords for an almost limitless number of systems and applications. For example, authentication of a user may provide the user access to password, login, financial credentials, or the like, associated with multiple online vendors, a local area network, various personal computing devices, Internet service providers, auction providers, investment brokerages, or the like. By employing a sensitive data vault, users may choose truly large and random passwords because they no longer need to remember them through association. Rather, the authentication process 1000 provides access thereto. For example, a user may choose a random alphanumeric string that is twenty plus digits in length rather than something associated with a memorable data, name, etc.

[0152] According to one embodiment, a sensitive data vault associated with a given user may advantageously be stored in the data storage facilities of the depository 210, or split and stored in the depository system 700. According to this embodiment, after positive user authentication, the trust engine 110 serves the requested sensitive data, such as, for example, to the appropriate password to the requesting application. According to another embodiment, the trust engine 110 may include a separate system for storing the sensitive data vault. For example, the trust engine 110 may include a stand-alone software engine implementing the data vault functionality and figuratively residing "behind" the foregoing front-end security system of the trust engine 110. According to this embodiment, the software engine serves the requested sensitive data after the software engine receives a signal indicating positive user authentication from the trust engine 110.

[0153] In yet another embodiment, the data vault may be implemented by a third-party system. Similar to the software engine embodiment, the third-party system may advantageously serve the requested sensitive data after the third-party system receives a signal indicating positive user authentication from the trust engine 110. According to yet another embodiment, the data vault may be implemented on the user system 105. A user-side software engine may advantageously serve the foregoing data after receiving a signal indicating positive user authentication from the trust engine 110.

[0154] Although the foregoing data vaults are disclosed with reference to alternative embodiments, a skilled artisan will recognize from the disclosure herein, a wide number of additional implementations thereof. For example, a particular data vault may include aspects from some or all of the foregoing embodiments. In addition, any of the foregoing data vaults may employ one or more authentication requests at varying times. For example, any of the data vaults may require authentication every one or more transactions, periodically, every one or more sessions, every access to one or more Webpages or Websites, at one or more other specified intervals, or the like.

[0155] FIGURE 11 illustrates a data flow of a signing process 1100 according to aspects of an embodiment of the invention. As shown in FIGURE 11, the signing process 1100 includes steps similar to those of the authentication process 1000 described in the foregoing with reference to FIGURE 10. According to one embodiment of the invention, the signing process 1100 first authenticates the user and then performs one or more of several digital signing functions as will be discussed in further detail below. According to another embodiment, the signing process 1100 may advantageously store data related thereto, such as hashes of messages or documents, or the like. This data may advantageously be used in an

audit or any other event, such as for example, when a participating party attempts to repudiate a transaction.

[0156] As shown in FIGURE 11, during the authentication steps, the user and vendor may advantageously agree on a message, such as, for example, a contract. During signing, the signing process 1100 advantageously ensures that the contract signed by the user is identical to the contract supplied by the vendor. Therefore, according to one embodiment, during authentication, the vendor and the user include a hash of their respective copies of the message or contract, in the data transmitted to the authentication engine 215. By employing only a hash of a message or contract, the trust engine 110 may advantageously store a significantly reduced amount of data, providing for a more efficient and cost effective cryptographic system. In addition, the stored hash may be advantageously compared to a hash of a document in question to determine whether the document in question matches one signed by any of the parties. The ability to determine whether the document is identical to one relating to a transaction provides for additional evidence that can be used against a claim for repudiation by a party to a transaction.

[0157] In step 1103, the authentication engine 215 assembles the enrollment authentication data and compares it to the current authentication data provided by the user. When the comparator of the authentication engine 215 indicates that the enrollment authentication data matches the current authentication data, the comparator of the authentication engine 215 also compares the hash of the message supplied by the vendor to the hash of the message supplied by the user. Thus, the authentication engine 215 advantageously ensures that the message agreed to by the user is identical to that agreed to by the vendor.

[0158] In step 1105, the authentication engine 215 transmits a digital signature request to the cryptographic engine 220. According to one embodiment of the invention, the request includes a hash of the message or contract. However, a skilled artisan will recognize from the disclosure herein that the cryptographic engine 220 may encrypt virtually any type of data, including, but not limited to, video, audio, biometrics, images or text to form the desired digital signature. Returning to step 1105, the digital signature request preferably comprises an XML document communicated through conventional SSL technologies.

[0159] In step 1110, the authentication engine 215 transmits a request to each of the data storage facilities D1 through D4, such that each of the data storage facilities D1 through D4 transmit their respective portion of the cryptographic key or keys corresponding to a signing party. According to another embodiment, the cryptographic engine 220 employs some or all of the steps of the interoperability process 970 discussed in the foregoing, such that the

cryptographic engine 220 first determines the appropriate key or keys to request from the depository 210 or the depository system 700 for the signing party, and takes actions to provide appropriate matching keys. According to still another embodiment, the authentication engine 215 or the cryptographic engine 220 may advantageously request one or more of the keys associated with the signing party and stored in the depository 210 or depository system 700.

[0160] According to one embodiment, the signing party includes one or both the user and the vendor. In such case, the authentication engine 215 advantageously requests the cryptographic keys corresponding to the user and/or the vendor. According to another embodiment, the signing party includes the trust engine 110. In this embodiment, the trust engine 110 is certifying that the authentication process 1000 properly authenticated the user, vendor, or both. Therefore, the authentication engine 215 requests the cryptographic key of the trust engine 110, such as, for example, the key belonging to the cryptographic engine 220, to perform the digital signature. According to another embodiment, the trust engine 110 performs a digital notary-like function. In this embodiment, the signing party includes the user, vendor, or both, along with the trust engine 110. Thus, the trust engine 110 provides the digital signature of the user and/or vendor, and then indicates with its own digital signature that the user and/or vendor were properly authenticated. In this embodiment, the authentication engine 215 may advantageously request assembly of the cryptographic keys corresponding to the user, the vendor, or both. According to another embodiment, the authentication engine 215 may advantageously request assembly of the cryptographic keys corresponding to the trust engine 110.

[0161] According to another embodiment, the trust engine 110 performs power of attorney-like functions. For example, the trust engine 110 may digitally sign the message on behalf of a third party. In such case, the authentication engine 215 requests the cryptographic keys associated with the third party. According to this embodiment, the signing process 1100 may advantageously include authentication of the third party, before allowing power of attorney-like functions. In addition, the authentication process 1000 may include a check for third party constraints, such as, for example, business logic or the like dictating when and in what circumstances a particular third-party's signature may be used.

[0162] Based on the foregoing, in step 1110, the authentication engine requested the cryptographic keys from the data storage facilities D1 through D4 corresponding to the signing party. In step 1115, the data storage facilities D1 through D4 transmit their respective portions of the cryptographic key corresponding to the signing party to the cryptographic

engine 220. According to one embodiment, the foregoing transmissions include SSL technologies. According to another embodiment, the foregoing transmissions may advantageously be super-encrypted with the public key of the cryptographic engine 220.

[0163] In step 1120, the cryptographic engine 220 assembles the foregoing cryptographic keys of the signing party and encrypts the message therewith, thereby forming the digital signature(s). In step 1125 of the signing process 1100, the cryptographic engine 220 transmits the digital signature(s) to the authentication engine 215. In step 1130, the authentication engine 215 transmits the filled-in authentication request along with a copy of the hashed message and the digital signature(s) to the transaction engine 205. In step 1135, the transaction engine 205 transmits a receipt comprising the transaction ID, an indication of whether the authentication was successful, and the digital signature(s), to the vendor. According to one embodiment, the foregoing transmission may advantageously include the digital signature of the trust engine 110. For example, the trust engine 110 may encrypt the hash of the receipt with its private key, thereby forming a digital signature to be attached to the transmission to the vendor.

[0164] According to one embodiment, the transaction engine 205 also transmits a confirmation message to the user. Although the signing process 1100 is disclosed with reference to its preferred and alternative embodiments, the invention is not intended to be limited thereby. Rather, a skilled artisan will recognize from the disclosure herein, a wide number of alternatives for the signing process 1100. For example, the vendor may be replaced with a user application, such as an email application. For example, the user may wish to digitally sign a particular email with his or her digital signature. In such an embodiment, the transmission throughout the signing process 1100 may advantageously include only one copy of a hash of the message. Moreover, a skilled artisan will recognize from the disclosure herein that a wide number of client applications may request digital signatures. For example, the client applications may comprise word processors, spreadsheets, emails, voicemail, access to restricted system areas, or the like.

[0165] In addition, a skilled artisan will recognize from the disclosure herein that steps 1105 through 1120 of the signing process 1100 may advantageously employ some or all of the steps of the interoperability process 970 of FIGURE 9B, thereby providing interoperability between differing cryptographic systems that may, for example, need to process the digital signature under differing signature types.

[0166] FIGURE 12 illustrates a data flow of an encryption/decryption process 1200 according to aspects of an embodiment of the invention. As shown in FIGURE 12, the

decryption process 1200 begins by authenticating the user using the authentication process 1000. According to one embodiment, the authentication process 1000 includes in the authentication request, a synchronous session key. For example, in conventional PKI technologies, it is understood by skilled artisans that encrypting or decrypting data using public and private keys is mathematically intensive and may require significant system resources. However, in symmetric key cryptographic systems, or systems where the sender and receiver of a message share a single common key that is used to encrypt and decrypt a message, the mathematical operations are significantly simpler and faster. Thus, in the conventional PKI technologies, the sender of a message will generate synchronous session key, and encrypt the message using the simpler, faster symmetric key system. Then, the sender will encrypt the session key with the public key of the receiver. The encrypted session key will be attached to the synchronously encrypted message and both data are sent to the receiver. The receiver uses his or her private key to decrypt the session key, and then uses the session key to decrypt the message. Based on the foregoing, the simpler and faster symmetric key system is used for the majority of the encryption/decryption processing. Thus, in the decryption process 1200, the decryption advantageously assumes that a synchronous key has been encrypted with the public key of the user. Thus, as mentioned in the foregoing, the encrypted session key is included in the authentication request.

[0167] Returning to the decryption process 1200, after the user has been authenticated in step 1205, the authentication engine 215 forwards the encrypted session key to the cryptographic engine 220. In step 1210, the authentication engine 215 forwards a request to each of the data storage facilities, D1 through D4, requesting the cryptographic key data of the user. In step 1215, each data storage facility, D1 through D4, transmits their respective portion of the cryptographic key to the cryptographic engine 220. According to one embodiment, the foregoing transmission is encrypted with the public key of the cryptographic engine 220.

[0168] In step 1220 of the decryption process 1200, the cryptographic engine 220 assembles the cryptographic key and decrypts the session key therewith. In step 1225, the cryptographic engine forwards the session key to the authentication engine 215. In step 1227, the authentication engine 215 fills in the authentication request including the decrypted session key, and transmits the filled-in authentication request to the transaction engine 205. In step 1230, the transaction engine 205 forwards the authentication request along with the session key to the requesting application or vendor. Then, according to one embodiment, the requesting application or vendor uses the session key to decrypt the encrypted message.

[0169] Although the decryption process 1200 is disclosed with reference to its preferred and alternative embodiments, a skilled artisan will recognize from the disclosure herein, a wide number of alternatives for the decryption process 1200. For example, the decryption process 1200 may forego synchronous key encryption and rely on full public-key technology. In such an embodiment, the requesting application may transmit the entire message to the cryptographic engine 220, or, may employ some type of compression or reversible hash in order to transmit the message to the cryptographic engine 220. A skilled artisan will also recognize from the disclosure herein that the foregoing communications may advantageously include XML documents wrapped in SSL technology.

[0170] The encryption/decryption process 1200 also provides for encryption of documents or other data. Thus, in step 1235, a requesting application or vendor may advantageously transmit to the transaction engine 205 of the trust engine 110, a request for the public key of the user. The requesting application or vendor makes this request because the requesting application or vendor uses the public key of the user, for example, to encrypt the session key that will be used to encrypt the document or message. As mentioned in the enrollment process 900, the transaction engine 205 stores a copy of the digital certificate of the user, for example, in the mass storage 225. Thus, in step 1240 of the encryption process 1200, the transaction engine 205 requests the digital certificate of the user from the mass storage 225. In step 1245, the mass storage 225 transmits the digital certificate corresponding to the user, to the transaction engine 205. In step 1250, the transaction engine 205 transmits the digital certificate to the requesting application or vendor. According to one embodiment, the encryption portion of the encryption process 1200 does not include the authentication of a user. This is because the requesting vendor needs only the public key of the user, and is not requesting any sensitive data.

[0171] A skilled artisan will recognize from the disclosure herein that if a particular user does not have a digital certificate, the trust engine 110 may employ some or all of the enrollment process 900 in order to generate a digital certificate for that particular user. Then, the trust engine 110 may initiate the encryption/decryption process 1200 and thereby provide the appropriate digital certificate. In addition, a skilled artisan will recognize from the disclosure herein that steps 1220 and 1235 through 1250 of the encryption/decryption process 1200 may advantageously employ some or all of the steps of the interoperability process of FIGURE 9B, thereby providing interoperability between differing cryptographic systems that may, for example, need to process the encryption.

[0172] FIGURE 13 illustrates a simplified block diagram of a trust engine system 1300 according to aspects of yet another embodiment of the invention. As shown in FIGURE 13, the trust engine system 1300 comprises a plurality of distinct trust engines 1305, 1310, 1315, and 1320, respectively. To facilitate a more complete understanding of the invention, FIGURE 13 illustrates each trust engine, 1305, 1310, 1315, and 1320 as having a transaction engine, a depository, and an authentication engine. However, a skilled artisan will recognize that each transaction engine may advantageously comprise some, a combination, or all of the elements and communication channels disclosed with reference to FIGURES 1-8. For example, one embodiment may advantageously include trust engines having one or more transaction engines, depositories, and cryptographic servers or any combinations thereof.

[0173] According to one embodiment of the invention, each of the trust engines 1305, 1310, 1315 and 1320 are geographically separated, such that, for example, the trust engine 1305 may reside in a first location, the trust engine 1310 may reside in a second location, the trust engine 1315 may reside in a third location, and the trust engine 1320 may reside in a fourth location. The foregoing geographic separation advantageously decreases system response time while increasing the security of the overall trust engine system 1300.

[0174] For example, when a user logs onto the cryptographic system 100, the user may be nearest the first location and may desire to be authenticated. As described with reference to FIGURE 10, to be authenticated, the user provides current authentication data, such as a biometric or the like, and the current authentication data is compared to that user's enrollment authentication data. Therefore, according to one example, the user advantageously provides current authentication data to the geographically nearest trust engine 1305. The transaction engine 1321 of the trust engine 1305 then forwards the current authentication data to the authentication engine 1322 also residing at the first location. According to another embodiment, the transaction engine 1321 forwards the current authentication data to one or more of the authentication engines of the trust engines 1310, 1315, or 1320.

[0175] The transaction engine 1321 also requests the assembly of the enrollment authentication data from the depositories of, for example, each of the trust engines, 1305 through 1320. According to this embodiment, each depository provides its portion of the enrollment authentication data to the authentication engine 1322 of the trust engine 1305. The authentication engine 1322 then employs the encrypted data portions from, for example, the first two depositories to respond, and assembles the enrollment authentication data into deciphered form. The authentication engine 1322 compares the enrollment authentication

data with the current authentication data and returns an authentication result to the transaction engine 1321 of the trust engine 1305.

[0176] Based on the above, the trust engine system 1300 employs the nearest one of a plurality of geographically separated trust engines, 1305 through 1320, to perform the authentication process. According to one embodiment of the invention, the routing of information to the nearest transaction engine may advantageously be performed at client-side applets executing on one or more of the user system 105, vendor system 120, or certificate authority 115. According to an alternative embodiment, a more sophisticated decision process may be employed to select from the trust engines 1305 through 1320. For example, the decision may be based on the availability, operability, speed of connections, load, performance, geographic proximity, or a combination thereof, of a given trust engine.

[0177] In this way, the trust engine system 1300 lowers its response time while maintaining the security advantages associated with geographically remote data storage facilities, such as those discussed with reference to FIGURE 7 where each data storage facility stores randomized portions of sensitive data. For example, a security compromise at, for example, the depository 1325 of the trust engine 1315 does not necessarily compromise the sensitive data of the trust engine system 1300. This is because the depository 1325 contains only non-decipherable randomized data that, without more, is entirely useless.

[0178] According to another embodiment, the trust engine system 1300 may advantageously include multiple cryptographic engines arranged similar to the authentication engines. The cryptographic engines may advantageously perform cryptographic functions such as those disclosed with reference to FIGURES 1-8. According to yet another embodiment, the trust engine system 1300 may advantageously replace the multiple authentication engines with multiple cryptographic engines, thereby performing cryptographic functions such as those disclosed with reference to FIGURES 1-8. According to yet another embodiment of the invention, the trust engine system 1300 may replace each multiple authentication engine with an engine having some or all of the functionality of the authentication engines, cryptographic engines, or both, as disclosed in the foregoing,

[0179] Although the trust engine system 1300 is disclosed with reference to its preferred and alternative embodiments, a skilled artisan will recognize that the trust engine system 1300 may comprise portions of trust engines 1305 through 1320. For example, the trust engine system 1300 may include one or more transaction engines, one or more depositories, one or more authentication engines, or one or more cryptographic engines or combinations thereof.

[0180] FIGURE 14 illustrates a simplified block diagram of a trust engine System 1400 according to aspects of yet another embodiment of the invention. As shown in FIGURE 14, the trust engine system 1400 includes multiple trust engines 1405, 1410, 1415 and 1420. According to one embodiment, each of the trust engines 1405, 1410, 1415 and 1420, comprise some or all of the elements of trust engine 110 disclosed with reference to FIGURES 1-8. According to this embodiment, when the client side applets of the user system 105, the vendor system 120, or the certificate authority 115, communicate with the trust engine system 1400, those communications are sent to the IP address of each of the trust engines 1405 through 1420. Further, each transaction engine of each of the trust engines, 1405, 1410, 1415, and 1420, behaves similar to the transaction engine 1321 of the trust engine 1305 disclosed with reference to FIGURE 13. For example, during an authentication process, each transaction engine of each of the trust engines 1405, 1410, 1415, and 1420 transmits the current authentication data to their respective authentication engines and transmits a request to assemble the randomized data stored in each of the depositories of each of the trust engines 1405 through 1420. FIGURE 14 does not illustrate all of these communications; as such illustration would become overly complex. Continuing with the authentication process, each of the depositories then communicates its portion of the randomized data to each of the authentication engines of the each of the trust engines 1405 through 1420. Each of the authentication engines of the each of the trust engines employs its comparator to determine whether the current authentication data matches the enrollment authentication data provided by the depositories of each of the trust engines 1405 through 1420. According to this embodiment, the result of the comparison by each of the authentication engines is then transmitted to a redundancy module of the other three trust engines. For example, the result of the authentication engine from the trust engine 1405 is transmitted to the redundancy modules of the trust engines 1410, 1415, and 1420. Thus, the redundancy module of the trust engine 1405 likewise receives the result of the authentication engines from the trust engines 1410, 1415, and 1420.

[0181] FIGURE 15 illustrates a block diagram of the redundancy module of FIGURE 14. The redundancy module comprises a comparator configured to receive the authentication result from three authentication engines and transmit that result to the transaction engine of the fourth trust engine. The comparator compares the authentication result form the three authentication engines, and if two of the results agree, the comparator concludes that the authentication result should match that of the two agreeing authentication engines. This result

is then transmitted back to the transaction engine corresponding to the trust engine not associated with the three authentication engines.

[0182] Based on the foregoing, the redundancy module determines an authentication result from data received from authentication engines that are preferably geographically remote from the trust engine of that the redundancy module. By providing such redundancy functionality, the trust engine system 1400 ensures that a compromise of the authentication engine of one of the trust engines 1405 through 1420, is insufficient to compromise the authentication result of the redundancy module of that particular trust engine. A skilled artisan will recognize that redundancy module functionality of the trust engine system 1400 may also be applied to the cryptographic engine of each of the trust engines 1405 through 1420. However, such cryptographic engine communication was not shown in FIGURE 14 to avoid complexity. Moreover, a skilled artisan will recognize a wide number of alternative authentication result conflict resolution algorithms for the comparator of FIGURE 15 are suitable for use in the present invention.

[0183] According to yet another embodiment of the invention, the trust engine system 1400 may advantageously employ the redundancy module during cryptographic comparison steps. For example, some or all of the foregoing redundancy module disclosure with reference to FIGURES 14 and 15 may advantageously be implemented during a hash comparison of documents provided by one or more parties during a particular transaction.

[0184] Although the foregoing invention has been described in terms of certain preferred and alternative embodiments, other embodiments will be apparent to those of ordinary skill in the art from the disclosure herein. For example, the trust engine 110 may issue short-term certificates, where the private cryptographic key is released to the user for a predetermined period of time. For example, current certificate standards include a validity field that can be set to expire after a predetermined amount of time. Thus, the trust engine 110 may release a private key to a user where the private key would be valid for, for example, 24 hours. According to such an embodiment, the trust engine 110 may advantageously issue a new cryptographic key pair to be associated with a particular user and then release the private key of the new cryptographic key pair. Then, once the private cryptographic key is released, the trust engine 110 immediately expires any internal valid use of such private key, as it is no longer securable by the trust engine 110.

[0185] In addition, a skilled artisan will recognize that the cryptographic system 100 or the trust engine 110 may include the ability to recognize any type of devices, such as, but not limited to, a laptop, a cell phone, a network, a biometric device or the like. According to one

embodiment, such recognition may come from data supplied in the request for a particular service, such as, a request for authentication leading to access or use, a request for cryptographic functionality, or the like. According to one embodiment, the foregoing request may include a unique device identifier, such as, for example, a processor ID. Alternatively, the request may include data in a particular recognizable data format. For example, mobile and satellite phones often do not include the processing power for full X509.v3 heavy encryption certificates, and therefore do not request them. According to this embodiment, the trust engine 110 may recognize the type of data format presented, and respond only in kind.

[0186] In an additional aspect of the system described above, context sensitive authentication can be provided using various techniques as will be described below. Context sensitive authentication, for example as shown in FIGURE 16, provides the possibility of evaluating not only the actual data which is sent by the user when attempting to authenticate himself, but also the circumstances surrounding the generation and delivery of that data. Such techniques may also support transaction specific trust arbitrage between the user and trust engine 110 or between the vendor and trust engine 110, as will be described below.

[0187] As discussed above, authentication is the process of proving that a user is who he says he is. Generally, authentication requires demonstrating some fact to an authentication authority. The trust engine 110 of the present invention represents the authority to which a user must authenticate himself. The user must demonstrate to the trust engine 110 that he is who he says he is by either: knowing something that only the user should know (knowledge-based authentication), having something that only the user should have (token-based authentication), or by being something that only the user should be (biometric-based authentication).

[0188] Examples of knowledge-based authentication include without limitation a password, PIN number, or lock combination. Examples of token-based authentication include without limitation a house key, a physical credit card, a driver's license, or a particular phone number. Examples of biometric-based authentication include without limitation a fingerprint, handwriting analysis, facial scan, hand scan, ear scan, iris scan, vascular pattern, DNA, a voice analysis, or a retinal scan.

[0189] Each type of authentication has particular advantages and disadvantages, and each provides a different level of security. For example, it is generally harder to create a false fingerprint that matches someone else's than it is to overhear someone's password and repeat it. Each type of authentication also requires a different type of data to be known to the authenticating authority in order to verify someone using that form of authentication.

[0190] As used herein, "authentication" will refer broadly to the overall process of verifying someone's identity to be who he says he is. An "authentication technique" will refer to a particular type of authentication based upon a particular piece of knowledge, physical token, or biometric reading. "Authentication data" refers to information which is sent to or otherwise demonstrated to an authentication authority in order to establish identity. "Enrollment data" will refer to the data which is initially submitted to an authentication authority in order to establish a baseline for comparison with authentication data. An "authentication instance" will refer to the data associated with an attempt to authenticate by an authentication technique.

[0191] The internal protocols and communications involved in the process of authenticating a user is described with reference to FIGURE 10 above. The part of this process within which the context sensitive authentication takes place occurs within the comparison step shown as step 1045 of FIGURE 10. This step takes place within the authentication engine 215 and involves assembling the enrollment data 410 retrieved from the depository 210 and comparing the authentication data provided by the user to it. One particular embodiment of this process is shown in FIGURE 16 and described below.

[0192] The current authentication data provided by the user and the enrollment data retrieved from the depository 210 are received by the authentication engine 215 in step 1600 of FIGURE 16. Both of these sets of data may contain data which is related to separate techniques of authentication. The authentication engine 215 separates the authentication data associated with each individual authentication instance in step 1605. This is necessary so that the authentication data is compared with the appropriate subset of the enrollment data for the user (e.g. fingerprint authentication data should be compared with fingerprint enrollment data, rather than password enrollment data).

[0193] Generally, authenticating a user involves one or more individual authentication instances, depending on which authentication techniques are available to the user. These methods are limited by the enrollment data which were provided by the user during his enrollment process (if the user did not provide a retinal scan when enrolling, he will not be able to authenticate himself using a retinal scan), as well as the means which may be currently available to the user (e.g. if the user does not have a fingerprint reader at his current location, fingerprint authentication will not be practical). In some cases, a single authentication instance may be sufficient to authenticate a user; however, in certain circumstances a combination of multiple authentication instances may be used in order to more confidently authenticate a user for a particular transaction.

[0194] Each authentication instance consists of data related to a particular authentication technique (e.g. fingerprint, password, smart card, etc.) and the circumstances which surround the capture and delivery of the data for that particular technique. For example, a particular instance of attempting to authenticate via password will generate not only the data related to the password itself, but also circumstantial data, known as "metadata", related to that password attempt. This circumstantial data includes information such as: the time at which the particular authentication instance took place, the network address from which the authentication information was delivered, as well as any other information as is known to those of skill in the art which may be determined about the origin of the authentication data (the type of connection, the processor serial number, etc.).

[0195] In many cases, only a small amount of circumstantial metadata will be available. For example, if the user is located on a network which uses proxies or network address translation or another technique which masks the address of the originating computer, only the address of the proxy or router may be determined. Similarly, in many cases information such as the processor serial number will not be available because of either limitations of the hardware or operating system being used, disabling of such features by the operator of the system, or other limitations of the connection between the user's system and the trust engine 110.

[0196] As shown in FIGURE 16, once the individual authentication instances represented within the authentication data are extracted and separated in step 1605, the authentication engine 215 evaluates each instance for its reliability in indicating that the user is who he claims to be. The reliability for a single authentication instance will generally be determined based on several factors. These may be grouped as factors relating to the reliability associated with the authentication technique, which are evaluated in step 1610, and factors relating to the reliability of the particular authentication data provided, which are evaluated in step 1815. The first group includes without limitation the inherent reliability of the authentication technique being used, and the reliability of the enrollment data being used with that method. The second group includes without limitation the degree of match between the enrollment data and the data provided with the authentication instance, and the metadata associated with that authentication instance. Each of these factors may vary independently of the others.

[0197] The inherent reliability of an authentication technique is based on how hard it is for an imposter to provide someone else's correct data, as well as the overall error rates for the authentication technique. For passwords and knowledge based authentication methods, this reliability is often fairly low because there is nothing that prevents someone from revealing

their password to another person and for that second person to use that password. Even a more complex knowledge based system may have only moderate reliability since knowledge may be transferred from person to person fairly easily. Token based authentication, such as having a proper smart card or using a particular terminal to perform the authentication, is similarly of low reliability used by itself, since there is no guarantee that the right person is in possession of the proper token.

[0198] However, biometric techniques are more inherently reliable because it is generally difficult to provide someone else with the ability to use your fingerprints in a convenient manner, even intentionally. Because subverting biometric authentication techniques is more difficult, the inherent reliability of biometric methods is generally higher than that of purely knowledge or token based authentication techniques. However, even biometric techniques may have some occasions in which a false acceptance or false rejection is generated. These occurrences may be reflected by differing reliabilities for different implementations of the same biometric technique. For example, a fingerprint matching system provided by one company may provide a higher reliability than one provided by a different company because one uses higher quality optics or a better scanning resolution or some other improvement which reduces the occurrence of false acceptances or false rejections.

[0199] Note that this reliability may be expressed in different manners. The reliability is desirably expressed in some metric which can be used by the heuristics 530 and algorithms of the authentication engine 215 to calculate the confidence level of each authentication. One preferred mode of expressing these reliabilities is as a percentage or fraction. For instance, fingerprints might be assigned an inherent reliability of 97%, while passwords might only be assigned an inherent reliability of 50%. Those of skill in the art will recognize that these particular values are merely exemplary and may vary between specific implementations.

[0200] The second factor for which reliability must be assessed is the reliability of the enrollment. This is part of the "graded enrollment" process referred to above. This reliability factor reflects the reliability of the identification provided during the initial enrollment process. For instance, if the individual initially enrolls in a manner where they physically produce evidence of their identity to a notary or other public official, and enrollment data is recorded at that time and notarized, the data will be more reliable than data which is provided over a network during enrollment and only vouched for by a digital signature or other information which is not truly tied to the individual.

[0201] Other enrollment techniques with varying levels of reliability include without limitation: enrollment at a physical office of the trust engine 110 operator; enrollment at a

user's place of employment; enrollment at a post office or passport office; enrollment through an affiliated or trusted party to the trust engine 110 operator; anonymous or pseudonymous enrollment in which the enrolled identity is not yet identified with a particular real individual, as well as such other means as are known in the art.

[0202] These factors reflect the trust between the trust engine 110 and the source of identification provided during the enrollment process. For instance, if enrollment is performed in association with an employer during the initial process of providing evidence of identity, this information may be considered extremely reliable for purposes within the company, but may be trusted to a lesser degree by a government agency, or by a competitor. Therefore, trust engines operated by each of these other organizations may assign different levels of reliability to this enrollment.

[0203] Similarly, additional data which is submitted across a network, but which is authenticated by other trusted data provided during a previous enrollment with the same trust engine 110 may be considered as reliable as the original enrollment data was, even though the latter data were submitted across an open network. In such circumstances, a subsequent notarization will effectively increase the level of reliability associated with the original enrollment data. In this way for example, an anonymous or pseudonymous enrollment may then be raised to a full enrollment by demonstrating to some enrollment official the identity of the individual matching the enrolled data.

[0204] The reliability factors discussed above are generally values which may be determined in advance of any particular authentication instance. This is because they are based upon the enrollment and the technique, rather than the actual authentication. In one embodiment, the step of generating reliability based upon these factors involves looking up previously determined values for this particular authentication technique and the enrollment data of the user. In a further aspect of an advantageous embodiment of the present invention, such reliabilities may be included with the enrollment data itself. In this way, these factors are automatically delivered to the authentication engine 215 along with the enrollment data sent from the depository 210.

[0205] While these factors may generally be determined in advance of any individual authentication instance, they still have an effect on each authentication instance which uses that particular technique of authentication for that user. Furthermore, although the values may change over time (e.g. if the user re-enrolls in a more reliable fashion), they are not dependent on the authentication data itself. By contrast, the reliability factors associated with a single

specific instance's data may vary on each occasion. These factors, as discussed below, must be evaluated for each new authentication in order to generate reliability scores in step 1815.

[0206] The reliability of the authentication data reflects the match between the data provided by the user in a particular authentication instance and the data provided during the authentication enrollment. This is the fundamental question of whether the authentication data matches the enrollment data for the individual the user is claiming to be. Normally, when the data do not match, the user is considered to not be successfully authenticated, and the authentication fails. The manner in which this is evaluated may change depending on the authentication technique used. The comparison of such data is performed by the comparator 515 function of the authentication engine 215 as shown in FIGURE 5.

[0207] For instance, matches of passwords are generally evaluated in a binary fashion. In other words, a password is either a perfect match, or a failed match. It is usually not desirable to accept as even a partial match a password which is close to the correct password if it is not exactly correct. Therefore, when evaluating a password authentication, the reliability of the authentication returned by the comparator 515 is typically either 100% (correct) or 0% (wrong), with no possibility of intermediate values.

[0208] Similar rules to those for passwords are generally applied to token based authentication methods, such as smart cards. This is because having a smart card which has a similar identifier or which is similar to the correct one, is still just as wrong as having any other incorrect token. Therefore tokens tend also to be binary authenticators: a user either has the right token, or he doesn't.

[0209] However, certain types of authentication data, such as questionnaires and biometrics, are generally not binary authenticators. For example, a fingerprint may match a reference fingerprint to varying degrees. To some extent, this may be due to variations in the quality of the data captured either during the initial enrollment or in subsequent authentications. (A fingerprint may be smudged or a person may have a still healing scar or burn on a particular finger.) In other instances the data may match less than perfectly because the information itself is somewhat variable and based upon pattern matching. (A voice analysis may seem close but not quite right because of background noise, or the acoustics of the environment in which the voice is recorded, or because the person has a cold.) Finally, in situations where large amounts of data are being compared, it may simply be the case that much of the data matches well, but some doesn't. (A ten-question questionnaire may have resulted in eight correct answers to personal questions, but two incorrect answers.) For any of these reasons, the match between the enrollment data and the data for a particular authentication instance

may be desirably assigned a partial match value by the comparator 515. In this way, the fingerprint might be said to be a 85% match, the voice print a 65% match, and the questionnaire an 80% match, for example.

[0210] This measure (degree of match) produced by the comparator 515 is the factor representing the basic issue of whether an authentication is correct or not. However, as discussed above, this is only one of the factors which may be used in determining the reliability of a given authentication instance. Note also that even though a match to some partial degree may be determined, that ultimately, it may be desirable to provide a binary result based upon a partial match. In an alternate mode of operation, it is also possible to treat partial matches as binary, i.e. either perfect (100%) or failed (0%) matches, based upon whether or not the degree of match passes a particular threshold level of match. Such a process may be used to provide a simple pass/fail level of matching for systems which would otherwise produce partial matches.

[0211] Another factor to be considered in evaluating the reliability of a given authentication instance concerns the circumstances under which the authentication data for this particular instance are provided. As discussed above, the circumstances refer to the metadata associated with a particular authentication instance. This may include without limitation such information as: the network address of the authenticator, to the extent that it can be determined; the time of the authentication; the mode of transmission of the authentication data (phone line, cellular, network, etc.); and the serial number of the system of the authenticator.

[0212] These factors can be used to produce a profile of the type of authentication that is normally requested by the user. Then, this information can be used to assess reliability in at least two manners. One manner is to consider whether the user is requesting authentication in a manner which is consistent with the normal profile of authentication by this user. If the user normally makes authentication requests from one network address during business days (when she is at work) and from a different network address during evenings or weekends (when she is at home), an authentication which occurs from the home address during the business day is less reliable because it is outside the normal authentication profile. Similarly, if the user normally authenticates using a fingerprint biometric and in the evenings, an authentication which originates during the day using only a password is less reliable.

[0213] An additional way in which the circumstantial metadata can be used to evaluate the reliability of an instance of authentication is to determine how much corroboration the circumstance provides that the authenticator is the individual he claims to be. For instance, if the authentication comes from a system with a serial number known to be associated with the

user, this is a good circumstantial indicator that the user is who they claim to be. Conversely, if the authentication is coming from a network address which is known to be in Los Angeles when the user is known to reside in London, this is an indication that this authentication is less reliable based on its circumstances.

[0214] It is also possible that a cookie or other electronic data may be placed upon the system being used by a user when they interact with a vendor system or with the trust engine 110. This data is written to the storage of the system of the user and may contain an identification which may be read by a Web browser or other software on the user system. If this data is allowed to reside on the user system between sessions (a "persistent cookie"), it may be sent with the authentication data as further evidence of the past use of this system during authentication of a particular user. In effect, the metadata of a given instance, particularly a persistent cookie, may form a sort of token based authenticator itself.

[0215] Once the appropriate reliability factors based on the technique and data of the authentication instance are generated as described above in steps 1610 and 1615 respectively, they are used to produce an overall reliability for the authentication instance provided in step 1620. One means of doing this is simply to express each reliability as a percentage and then to multiply them together.

[0216] For example, suppose the authentication data is being sent in from a network address known to be the user's home computer completely in accordance with the user's past authentication profile (100%), and the technique being used is fingerprint identification (97%), and the initial finger print data was roistered through the user's employer with the trust engine 110 (90%), and the match between the authentication data and the original fingerprint template in the enrollment data is very good (99%). The overall reliability of this authentication instance could then be calculated as the product of these reliabilities: $100\% * 97\% * 90\% * 99\% = 86.4\%$ reliability.

[0217] This calculated reliability represents the reliability of one single instance of authentication. The overall reliability of a single authentication instance may also be calculated using techniques which treat the different reliability factors differently, for example by using formulas where different weights are assigned to each reliability factor. Furthermore, those of skill in the art will recognize that the actual values used may represent values other than percentages and may use non-arithmetic systems. One embodiment may include a module used by an authentication requestor to set the weights for each factor and the algorithms used in establishing the overall reliability of the authentication instance.

[0218] The authentication engine 215 may use the above techniques and variations thereof to determine the reliability of a single authentication instance, indicated as step 1620. However, it may be useful in many authentication situations for multiple authentication instances to be provided at the same time. For example, while attempting to authenticate himself using the system of the present invention, a user may provide a user identification, fingerprint authentication data, a smart card, and a password. In such a case, three independent authentication instances are being provided to the trust engine 110 for evaluation. Proceeding to step 1625, if the authentication engine 215 determines that the data provided by the user includes more than one authentication instance, then each instance in turn will be selected as shown in step 1630 and evaluated as described above in steps 1610, 1615 and 1620.

[0219] Note that many of the reliability factors discussed may vary from one of these instances to another. For instance, the inherent reliability of these techniques is likely to be different, as well as the degree of match provided between the authentication data and the enrollment data. Furthermore, the user may have provided enrollment data at different times and under different circumstances for each of these techniques, providing different enrollment reliabilities for each of these instances as well. Finally, even though the circumstances under which the data for each of these instances is being submitted is the same, the use of such techniques may each fit the profile of the user differently, and so may be assigned different circumstantial reliabilities. (For example, the user may normally use their password and fingerprint, but not their smart card.)

[0220] As a result, the final reliability for each of these authentication instances may be different from one another. However, by using multiple instances together, the overall confidence level for the authentication will tend to increase.

[0221] Once the authentication engine has performed steps 1610 through 1620 for all of the authentication instances provided in the authentication data, the reliability of each instance is used in step 1635 to evaluate the overall authentication confidence level. This process of combining the individual authentication instance reliabilities into the authentication confidence level may be modeled by various methods relating the individual reliabilities produced, and may also address the particular interaction between some of these authentication techniques. (For example, multiple knowledge-based systems such as passwords may produce less confidence than a single password and even a fairly weak biometric, such as a basic voice analysis.)

[0222] One means in which the authentication engine 215 may combine the reliabilities of multiple concurrent authentication instances to generate a final confidence level is to multiply the unreliability of each instance to arrive at a total unreliability. The unreliability is generally the complementary percentage of the reliability. For example, a technique which is 84% reliable is 16% unreliable. The three authentication instances described above (fingerprint, smart card, password) which produce reliabilities of 86%, 75%, and 72% would have corresponding unreliabilities of (100- 86)%, (100- 75)% and (100- 72)%, or 14%, 25%, and 28%, respectively. By multiplying these unreliabilities, we get a cumulative unreliability of $14\% * 25\% * 28\% = .98\%$ unreliability, which corresponds to a reliability of 99.02%.

[0223] In an additional mode of operation, additional factors and heuristics 530 may be applied within the authentication engine 215 to account for the interdependence of various authentication techniques. For example, if someone has unauthorized access to a particular home computer, they probably have access to the phone line at that address as well. Therefore, authenticating based on an originating phone number as well as upon the serial number of the authenticating system does not add much to the overall confidence in the authentication. However, knowledge based authentication is largely independent of token based authentication (i.e. if someone steals your cellular phone or keys, they are no more likely to know your PIN or password than if they hadn't).

[0224] Furthermore, different vendors or other authentication requestors may wish to weigh different aspects of the authentication differently. This may include the use of separate weighing factors or algorithms used in calculating the reliability of individual instances as well as the use of different means to evaluate authentication events with multiple instances.

[0225] For instance, vendors for certain types of transactions, for instance corporate email systems, may desire to authenticate primarily based upon heuristics and other circumstantial data by default. Therefore, they may apply high weights to factors related to the metadata and other profile related information associated with the circumstances surrounding authentication events. This arrangement could be used to ease the burden on users during normal operating hours, by not requiring more from the user than that he be logged on to the correct machine during business hours. However, another vendor may weigh authentications coming from a particular technique most heavily, for instance fingerprint matching, because of a policy decision that such a technique is most suited to authentication for the particular vendor's purposes.

[0226] Such varying weights may be defined by the authentication requestor in generating the authentication request and sent to the trust engine 110 with the authentication request in

one mode of operation. Such options could also be set as preferences during an initial enrollment process for the authentication requestor and stored within the authentication engine in another mode of operation.

[0227] Once the authentication engine 215 produces an authentication confidence level for the authentication data provided, this confidence level is used to complete the authentication request in step 1640, and this information is forwarded from the authentication engine 215 to the transaction engine 205 for inclusion in a message to the authentication requestor.

[0228] The process described above is merely exemplary, and those of skill in the art will recognize that the steps need not be performed in the order shown or that only certain of the steps are desired to be performed, or that a variety of combinations of steps may be desired. Furthermore, certain steps, such as the evaluation of the reliability of each authentication instance provided, may be carried out in parallel with one another if circumstances permit.

[0229] In a further aspect of this invention, a method is provided to accommodate conditions when the authentication confidence level produced by the process described above fails to meet the required trust level of the vendor or other party requiring the authentication. In circumstances such as these where a gap exists between the level of confidence provided and the level of trust desired, the operator of the trust engine 110 is in a position to provide opportunities for one or both parties to provide alternate data or requirements in order to close this trust gap. This process will be referred to as "trust arbitrage" herein.

[0230] Trust arbitrage may take place within a framework of cryptographic authentication as described above with reference to FIGURES 10 and 11. As shown therein, a vendor or other party will request authentication of a particular user in association with a particular transaction. In one circumstance, the vendor simply requests an authentication, either positive or negative, and after receiving appropriate data from the user, the trust engine 110 will provide such a binary authentication. In circumstances such as these, the degree of confidence required in order to secure a positive authentication is determined based upon preferences set within the trust engine 110.

[0231] However, it is also possible that the vendor may request a particular level of trust in order to complete a particular transaction. This required level may be included with the authentication request (e.g. authenticate this user to 98% confidence) or may be determined by the trust engine 110 based on other factors associated with the transaction (i.e. authenticate this user as appropriate for this transaction). One such factor might be the economic value of the transaction. For transactions which have greater economic value, a higher degree of trust may be required. Similarly, for transactions with high degrees of risk a

high degree of trust may be required. Conversely, for transactions which are either of low risk or of low value, lower trust levels may be required by the vendor or other authentication requestor.

[0232] The process of trust arbitrage occurs between the steps of the trust engine 110 receiving the authentication data in step 1050 of FIGURE 10 and the return of an authentication result to the vendor in step 1055 of FIGURE 10. Between these steps, the process which leads to the evaluation of trust levels and the potential trust arbitrage occurs as shown in FIGURE 17. In circumstances where simple binary authentication is performed, the process shown in FIGURE 17 reduces to having the transaction engine 205 directly compare the authentication data provided with the enrollment data for the identified user as discussed above with reference to FIGURE 10, flagging any difference as a negative authentication.

[0233] As shown in FIGURE 17, the first step after receiving the data in step 1050 is for the transaction engine 205 to determine the trust level which is required for a positive authentication for this particular transaction in step 1710. This step may be performed by one of several different methods. The required trust level may be specified to the trust engine 110 by the authentication requestor at the time when the authentication request is made. The authentication requestor may also set a preference in advance which is stored within the depository 210 or other storage which is accessible by the transaction engine 205. This preference may then be read and used each time an authentication request is made by this authentication requestor. The preference may also be associated with a particular user as a security measure such that a particular level of trust is always required in order to authenticate that user, the user preference being stored in the depository 210 or other storage media accessible by the transaction engine 205. The required level may also be derived by the transaction engine 205 or authentication engine 215 based upon information provided in the authentication request, such as the value and risk level of the transaction to be authenticated.

[0234] In one mode of operation, a policy management module or other software which is used when generating the authentication request is used to specify the required degree of trust for the authentication of the transaction. This may be used to provide a series of rules to follow when assigning the required level of trust based upon the policies which are specified within the policy management module. One advantageous mode of operation is for such a module to be incorporated with the web server of a vendor in order to appropriately determine required level of trust for transactions initiated with the vendor's web server. In this way, transaction requests from users may be assigned a required trust level in accordance with the

policies of the vendor and such information may be forwarded to the trust engine 110 along with the authentication request.

[0235] This required trust level correlates with the degree of certainty that the vendor wants to have that the individual authenticating is in fact who he identifies himself as. For example, if the transaction is one where the vendor wants a fair degree of certainty because goods are changing hands, the vendor may require a trust level of 85%. For situation where the vendor is merely authenticating the user to allow him to view members only content or exercise privileges on a chat room, the downside risk may be small enough that the vendor requires only a 60% trust level. However, to enter into a production contract with a value of tens of thousands of dollars, the vendor may require a trust level of 99% or more.

[0236] This required trust level represents a metric to which the user must authenticate himself in order to complete the transaction. If the required trust level is 85% for example, the user must provide authentication to the trust engine 110 sufficient for the trust engine 110 to say with 85% confidence that the user is who they say they are. It is the balance between this required trust level and the authentication confidence level which produces either a positive authentication (to the satisfaction of the vendor) or a possibility of trust arbitrage.

[0237] As shown in FIGURE 17, after the transaction engine 205 receives the required trust level, it compares in step 1720 the required trust level to the authentication confidence level which the authentication engine 215 calculated for the current authentication (as discussed with reference to FIGURE 16). If the authentication confidence level is higher than the required trust level for the transaction in step 1730, then the process moves to step 1740 where a positive authentication for this transaction is produced by the transaction engine 205. A message to this effect will then be inserted into the authentication results and returned to the vendor by the transaction engine 205 as shown in step 1055 (see FIGURE 10).

[0238] However, if the authentication confidence level does not fulfill the required trust level in step 1730, then a confidence gap exists for the current authentication, and trust arbitrage is conducted in step 1750. Trust arbitrage is described more completely with reference to FIGURE 18 below. This process as described below takes place within the transaction engine 205 of the trust engine 110. Because no authentication or other cryptographic operations are needed to execute trust arbitrage (other than those required for the SSL communication between the transaction engine 205 and other components), the process may be performed outside the authentication engine 215. However, as will be discussed below, any reevaluation of authentication data or other cryptographic or authentication events will require the transaction engine 205 to resubmit the appropriate data

to the authentication engine 215. Those of skill in the art will recognize that the trust arbitration process could alternately be structured to take place partially or entirely within the authentication engine 215 itself.

[0239] As mentioned above, trust arbitration is a process where the trust engine 110 mediates a negotiation between the vendor and user in an attempt to secure a positive authentication where appropriate. As shown in step 1805, the transaction engine 205 first determines whether or not the current situation is appropriate for trust arbitration. This may be determined based upon the circumstances of the authentication, e.g. whether this authentication has already been through multiple cycles of arbitration, as well as upon the preferences of either the vendor or user, as will be discussed further below.

[0240] In such circumstances where arbitration is not possible, the process proceeds to step 1810 where the transaction engine 205 generates a negative authentication and then inserts it into the authentication results which are sent to the vendor in step 1055 (see FIGURE 10). One limit which may be advantageously used to prevent authentications from pending indefinitely is to set a time-out period from the initial authentication request. In this way, any transaction which is not positively authenticated within the time limit is denied further arbitration and negatively authenticated. Those of skill in the art will recognize that such a time limit may vary depending upon the circumstances of the transaction and the desires of the user and vendor. Limitations may also be placed upon the number of attempts that may be made at providing a successful authentication. Such limitations may be handled by an attempt limiter 535 as shown in FIGURE 5.

[0241] If arbitration is not prohibited in step 1805, the transaction engine 205 will then engage in negotiation with one or both of the transacting parties. The transaction engine 205 may send a message to the user requesting some form of additional authentication in order to boost the authentication confidence level produced as shown in step 1820. In the simplest form, this may simply indicate that authentication was insufficient. A request to produce one or more additional authentication instances to improve the overall confidence level of the authentication may also be sent.

[0242] If the user provides some additional authentication instances in step 1825, then the transaction engine 205 adds these authentication instances to the authentication data for the transaction and forwards it to the authentication engine 215 as shown in step 1015 (see FIGURE 10), and the authentication is reevaluated based upon both the pre-existing authentication instances for this transaction and the newly provided authentication instances.

[0243] An additional type of authentication may be a request from the trust engine 110 to make some form of person-to-person contact between the trust engine 110 operator (or a trusted associate) and the user, for example, by phone call. This phone call or other non-computer authentication can be used to provide personal contact with the individual and also to conduct some form of questionnaire based authentication. This also may give the opportunity to verify an originating telephone number and potentially a voice analysis of the user when he calls in. Even if no additional authentication data can be provided, the additional context associated with the user's phone number may improve the reliability of the authentication context. Any revised data or circumstances based upon this phone call are fed into the trust engine 110 for use in consideration of the authentication request.

[0244] Additionally, in step 1820 the trust engine 110 may provide an opportunity for the user to purchase insurance, effectively buying a more confident authentication. The operator of the trust engine 110 may, at times, only want to make such an option available if the confidence level of the authentication is above a certain threshold to begin with. In effect, this user side insurance is a way for the trust engine 110 to vouch for the user when the authentication meets the normal required trust level of the trust engine 110 for authentication, but does not meet the required trust level of the vendor for this transaction. In this way, the user may still successfully authenticate to a very high level as may be required by the vendor, even though he only has authentication instances which produce confidence sufficient for the trust engine 110.

[0245] This function of the trust engine 110 allows the trust engine 110 to vouch for someone who is authenticated to the satisfaction of the trust engine 110, but not of the vendor. This is analogous to the function performed by a notary in adding his signature to a document in order to indicate to someone reading the document at a later time that the person whose signature appears on the document is in fact the person who signed it. The signature of the notary testifies to the act of signing by the user. In the same way, the trust engine is providing an indication that the person transacting is who they say they are.

[0246] However, because the trust engine 110 is artificially boosting the level of confidence provided by the user, there is a greater risk to the trust engine 110 operator, since the user is not actually meeting the required trust level of the vendor. The cost of the insurance is designed to offset the risk of a false positive authentication to the trust engine 110 (who may be effectively notarizing the authentications of the user). The user pays the trust engine 110 operator to take the risk of authenticating to a higher level of confidence than has actually been provided.

[0247] Because such an insurance system allows someone to effectively buy a higher confidence rating from the trust engine 110, both vendors and users may wish to prevent the use of user side insurance in certain transactions. Vendors may wish to limit positive authentications to circumstances where they know that actual authentication data supports the degree of confidence which they require and so may indicate to the trust engine 110 that user side insurance is not to be allowed. Similarly, to protect his online identity, a user may wish to prevent the use of user side insurance on his account, or may wish to limit its use to situations where the authentication confidence level without the insurance is higher than a certain limit. This may be used as a security measure to prevent someone from overhearing a password or stealing a smart card and using them to falsely authenticate to a low level of confidence, and then purchasing insurance to produce a very high level of (false) confidence. These factors may be evaluated in determining whether user side insurance is allowed.

[0248] If user purchases insurance in step 1840, then the authentication confidence level is adjusted based upon the insurance purchased in step 1845, and the authentication confidence level and required trust level are again compared in step 1730 (see FIGURE 17). The process continues from there, and may lead to either a positive authentication in step 1740 (see FIGURE 17), or back into the trust arbitrage process in step 1750 for either further arbitrage (if allowed) or a negative authentication in step 1810 if further arbitrage is prohibited.

[0249] In addition to sending a message to the user in step 1820, the transaction engine 205 may also send a message to the vendor in step 1830 which indicates that a pending authentication is currently below the required trust level. The message may also offer various options on how to proceed to the vendor. One of these Options is to simply inform the vendor of what the current authentication confidence level is and ask if the vendor wishes to maintain their current unfulfilled required trust level. This may be beneficial because in some cases, the vendor may have independent means for authenticating the transaction or may have been using a default set of requirements which generally result in a higher required level being initially specified than is actually needed for the particular transaction at hand.

[0250] For instance, it may be standard practice that all incoming purchase order transactions with the vendor are expected to meet a 98% trust level. However, if an order was recently discussed by phone between the vendor and a long-standing customer, and immediately thereafter the transaction is authenticated, but only to a 93% confidence level, the vendor may wish to simply lower the acceptance threshold for this transaction, because the phone call effectively provides additional authentication to the vendor. In certain circumstances, the vendor may be willing to lower their required trust level, but not all the

way to the level of the current authentication confidence. For instance, the vendor in the above example might consider that the phone call prior to the order might merit a 4% reduction in the degree of trust needed; however, this is still greater than the 93% confidence produced by the user.

[0251] If the vendor does adjust their required trust level in step 1835, then the authentication confidence level produced by the authentication and the required trust level are compared in step 1730 (see FIGURE 17). If the confidence level now exceeds the required trust level, a positive authentication may be generated in the transaction engine 205 in step 1740 (see FIGURE 17). If not, further arbitrage may be attempted as discussed above if it is permitted.

[0252] In addition to requesting an adjustment to the required trust level, the transaction engine 205 may also offer vendor side insurance to the vendor requesting the authentication. This insurance serves a similar purpose to that described above for the user side insurance. Here, however, rather than the cost corresponding to the risk being taken by the trust engine 110 in authenticating above the actual authentication confidence level produced, the cost of the insurance corresponds to the risk being taken by the vendor in accepting a lower trust level in the authentication.

[0253] Instead of just lowering their actual required trust level, the vendor has the option of purchasing insurance to protect itself from the additional risk associated with a lower level of trust in the authentication of the user. As described above, it may be advantageous for the vendor to only consider purchasing such insurance to cover the trust gap in conditions where the existing authentication is already above a certain threshold.

[0254] The availability of such vendor side insurance allows the vendor the option to either: lower his trust requirement directly at no additional cost to himself, bearing the risk of a false authentication himself (based on the lower trust level required); or, buying insurance for the trust gap between the authentication confidence level and his requirement, with the trust engine 110 operator bearing the risk of the lower confidence level which has been provided. By purchasing the insurance, the vendor effectively keeps his high trust level requirement; because the risk of a false authentication is shifted to the trust engine 110 operator.

[0255] If the vendor purchases insurance in step 1840, the authentication confidence level and required trust levels are compared in step 1730 (see FIGURE 17), and the process continues as described above.

[0256] Note that it is also possible that both the user and the vendor respond to messages from the trust engine 110. Those of skill in the art will recognize that there are multiple ways

in which such situations can be handled. One advantageous mode of handling the possibility of multiple responses is simply to treat the responses in a first-come, first-served manner. For example, if the vendor responds with a lowered required trust level and immediately thereafter the user also purchases insurance to raise his authentication level, the authentication is first reevaluated based upon the lowered trust requirement from the vendor. If the authentication is now positive, the user's insurance purchase is ignored. In another advantageous mode of operation, the user might only be charged for the level of insurance required to meet the new, lowered trust requirement of the vendor (if a trust gap remained even with the lowered vendor trust requirement).

[0257] If no response from either party is received during the trust arbitration process at step 1850 within the time limit set for the authentication, the arbitration is reevaluated in step 1805. This effectively begins the arbitration process again. If the time limit was final or other circumstances prevent further arbitration in step 1805, a negative authentication is generated by the transaction engine 205 in step 1810 and returned to the vendor in step 1055 (see FIGURE 10). If not, new messages may be sent to the user and vendor, and the process may be repeated as desired.

[0258] Note that for certain types of transactions, for instance, digitally signing documents which are not part of a transaction, there may not necessarily be a vendor or other third party; therefore the transaction is primarily between the user and the trust engine 110. In circumstances such as these, the trust engine 110 will have its own required trust level which must be satisfied in order to generate a positive authentication. However, in such circumstances, it will often not be desirable for the trust engine 110 to offer insurance to the user in order for him to raise the confidence of his own signature.

[0259] The process described above and shown in FIGURES 16-18 may be carried out using various communications modes as described above with reference to the trust engine 110. For instance, the messages may be web-based and sent using SSL connections between the trust engine 110 and applets downloaded in real time to browsers running on the user or vendor systems. In an alternate mode of operation, certain dedicated applications may be in use by the user and vendor which facilitate such arbitration and insurance transactions. In another alternate mode of operation, secure email operations may be used to mediate the arbitration described above, thereby allowing deferred evaluations and batch processing of authentications. Those of skill in the art will recognize that different communications modes may be used as are appropriate for the circumstances and authentication requirements of the vendor.

[0260] The following description with reference to FIGURE 19 describes a sample transaction which integrates the various aspects of the present invention as described above. This example illustrates the overall process between a user and a vendor as mediated by the trust engine 110. Although the various steps and components as described in detail above may be used to carry out the following transaction, the process illustrated focuses on the interaction between the trust engine 110, user and vendor.

[0261] The transaction begins when the user, while viewing web pages online, fills out an order form on the web site of the vendor in step 1900. The user wishes to submit this order form to the vendor, signed with his digital signature. In order to do this, the user submits the order form with his request for a signature to the trust engine 110 in step 1905. The user will also provide authentication data which will be used as described above to authenticate his identity.

[0262] In step 1910 the authentication data is compared to the enrollment data by the trust engine 110 as discussed above, and if a positive authentication is produced, the hash of the order form, signed with the private key of the user, is forwarded to the vendor along with the order form itself.

[0263] The vendor receives the signed form in step 1915, and then the vendor will generate an invoice or other contract related to the purchase to be made in step 1920. This contract is sent back to the user with a request for a signature in step 1925. The vendor also sends an authentication request for this contract transaction to the trust engine 110 in step 1930 including a hash of the contract which will be signed by both parties. To allow the contract to be digitally signed by both parties, the vendor also includes authentication data for itself so that the vendor's signature upon the contract can later be verified if necessary.

[0264] As discussed above, the trust engine 110 then verifies the authentication data provided by the vendor to confirm the vendor's identity, and if the data produces a positive authentication in step 1935, continues with step 1955 when the data is received from the user. If the vendor's authentication data does not match the enrollment data of the vendor to the desired degree, a message is returned to the vendor requesting further authentication. Trust arbitration may be performed here if necessary, as described above, in order for the vendor to successfully authenticate itself to the trust engine 110.

[0265] When the user receives the contract in step 1940, he reviews it, generates authentication data to sign it if it is acceptable in step 1945, and then sends a hash of the contract and his authentication data to the trust engine 110 in step 1950. The trust engine 110 verifies the authentication data in step 1955 and if the authentication is good, proceeds to

process the contract as described below. As discussed above with reference to FIGURES 17 and 18, trust arbitration may be performed as appropriate to close any trust gap which exists between the authentication confidence level and the required authentication level for the transaction.

[0266] The trust engine 110 signs the hash of the contract with the user's private key, and sends this signed hash to the vendor in step 1960, signing the complete message on its own behalf, i.e., including a hash of the complete message (including the user's signature) encrypted with the private key 510 of the trust engine 110. This message is received by the vendor in step 1965. The message represents a signed contract (hash of contract encrypted using user's private key) and a receipt from the trust engine 110 (the hash of the message including the signed contract, encrypted using the trust engine 110's private key).

[0267] The trust engine 110 similarly prepares a hash of the contract with the vendor's private key in step 1970, and forwards this to the user, signed by the trust engine 110. In this way, the user also receives a copy of the contract, signed by the vendor, as well as a receipt, signed by the trust engine 110, for delivery of the signed contract in step 1975.

[0268] In addition to the foregoing, an additional aspect of the invention provides a cryptographic Service Provider Module (SPM) which may be available to a client side application as a means to access functions provided by the trust engine 110 described above. One advantageous way to provide such a service is for the cryptographic SPM is to mediate communications between a third party Application Programming Interface (API) and a trust engine 110 which is accessible via a network or other remote connection. A sample cryptographic SPM is described below with reference to FIGURE 20.

[0269] For example, on a typical system, a number of API's are available to programmers. Each API provides a set of function calls which may be made by an application 2000 running upon the system. Examples of API's which provide programming interfaces suitable for cryptographic functions, authentication functions, and other security function include the Cryptographic API (CAPI) 2010 provided by Microsoft with its Windows operating systems, and the Common Data Security Architecture (CDSA), sponsored by IBM, Intel and other members of the Open Group. CAPI will be used as an exemplary security API in the discussion that follows. However, the cryptographic SPM described could be used with CDSA or other security API's as are known in the art.

[0270] This API is used by a user system 105 or vendor system 120 when a call is made for a cryptographic function. Included among these functions may be requests associated with performing various cryptographic operations, such as encrypting a document with a particular

key, signing a document, requesting a digital certificate, verifying a signature upon a signed document, and such other cryptographic functions as are described herein or known to those of skill in the art.

[0271] Such cryptographic functions are normally performed locally to the system upon which CAPI 2010 is located. This is because generally the functions called require the use of either resources of the local user system 105, such as a fingerprint reader, or software functions which are programmed using libraries which are executed on the local machine. Access to these local resources is normally provided by one or more Service Provider Modules (SPM's) 2015, 2020 as referred to above which provide resources with which the cryptographic functions are carried out. Such SPM's may include software libraries 2015 to perform encrypting or decrypting operations, or drivers and applications 2020 which are capable of accessing specialized hardware 2025, such as biometric scanning devices. In much the way that CAPI 2010 provides functions which may be used by an application 2000 of the system 105, the SPM's 2015, 2020 provide CAPI with access to the lower level functions and resources associated with the available services upon the system.

[0272] In accordance with the invention, it is possible to provide a cryptographic SPM 2030 which is capable of accessing the cryptographic functions provided by the trust engine 110 and making these functions available to an application 2000 through CAPI 2010. Unlike embodiments where CAPI 2010 is only able to access resources which are locally available through SPM's 2015, 2020, a cryptographic SPM 2030 as described herein would be able to submit requests for cryptographic operations to a remotely-located, network-accessible trust engine 110 in order to perform the operations desired.

[0273] For instance, if an application 2000 has a need for a cryptographic operation, such as signing a document, the application 2000 makes a function call to the appropriate CAPI 2010 function. CAPI 2010 in turn will execute this function, making use of the resources which are made available to it by the SPM's 2015, 2020 and the cryptographic SPM 2030. In the case of a digital signature function, the cryptographic SPM 2030 will generate an appropriate request which will be sent to the trust engine 110 across the communication link 125.

[0274] The operations which occur between the cryptographic SPM 2030 and the trust engine 110 are the same operations that would be possible between any other system and the trust engine 110. However, these functions are effectively made available to a user system 105 through CAPI 2010 such that they appear to be locally available upon the user system 105 itself. However, unlike ordinary SPM's 2015, 2020, the functions are being

carried out on the remote trust engine 110 and the results relayed to the cryptographic SPM 2030 in response to appropriate requests across the communication link 125.

[0275] This cryptographic SPM 2030 makes a number of operations available to the user system 105 or a vendor system 120 which might not otherwise be available. These functions include without limitation: encryption and decryption of documents; issuance of digital certificates; digital signing of documents; verification of digital signatures; and such other operations as will be apparent to those of skill in the art.

[0276] In a separate embodiment, the present invention comprises a complete system for performing the data securing methods of the present invention on any data set. The computer system of this embodiment comprises a data splitting module that comprises the functionality shown in FIGURE 8 and described herein. In one embodiment of the present invention, the data splitting module, sometimes referred to herein as a secure data parser, comprises a parser program or software suite which comprises data splitting, encryption and decryption, reconstitution or reassembly functionality. This embodiment may further comprise a data storage facility or multiple data storage facilities, as well. The data splitting module, or secure data parser, comprises a cross-platform software module suite which integrates within an electronic infrastructure, or as an add-on to any application which requires the ultimate security of its data elements. This parsing process operates on any type of data set, and on any and all file types, or in a database on any row, column or cell of data in that database.

[0277] The parsing process of the present invention may, in one embodiment, be designed in a modular tiered fashion, and any encryption process is suitable for use in the process of the present invention. The modular tiers of the parsing and splitting process of the present invention may include, but are not limited to, 1) cryptographic split, dispersed and securely stored in multiple locations; 2) encrypt, cryptographically split, dispersed and securely stored in multiple locations; 3) encrypt, cryptographically split, encrypt each share, then dispersed and securely stored in multiple locations; and 4) encrypt, cryptographically split, encrypt each share with a different type of encryption than was used in the first step, then dispersed and securely stored in multiple locations.

[0278] The process comprises, in one embodiment, splitting of the data according to the contents of a generated random number, or key and performing the same cryptographic splitting of the key used in the encryption of splitting of the data to be secured into two or more portions, or shares, of parsed and split data, and in one embodiment, preferably into four or more portions of parsed and split data, encrypting all of the portions, then scattering and storing these portions back into the database, or relocating them to any named device, fixed or

removable, depending on the requestor's need for privacy and security. Alternatively, in another embodiment, encryption may occur prior to the splitting of the data set by the splitting module or secure data parser. The original data processed as described in this embodiment is encrypted and obfuscated and is secured. The dispersion of the encrypted elements, if desired, can be virtually anywhere, including, but not limited to, a single server or data storage device, or among separate data storage facilities or devices. Encryption key management in one embodiment may be included within the software suite, or in another embodiment may be integrated into an existing infrastructure or any other desired location.

[0279] A cryptographic split (cryptosplit) partitions the data into N number of shares. The partitioning can be on any size unit of data, including an individual bit, bits, bytes, kilobytes, megabytes, or larger units, as well as any pattern or combination of data unit sizes whether predetermined or randomly generated. The units can also be of different sized, based on either a random or predetermined set of values. This means the data can be viewed as a sequence of these units. In this manner the size of the data units themselves may render the data more secure, for example by using one or more predetermined or randomly generated pattern, sequence or combination of data unit sizes. The units are then distributed (either randomly or by a predetermined set of values) into the N shares. This distribution could also involve a shuffling of the order of the units in the shares. It is readily apparent to those of ordinary skill in the art that the distribution of the data units into the shares may be performed according to a wide variety of possible selections, including but not limited to size-fixed, predetermined sizes, or one or more combination, pattern or sequence of data unit sizes that are predetermined or randomly generated.

[0280] In some embodiments of this cryptosplit split process, the data may be any suitable number of bytes in size, such as one, two, three, five, twenty, fifty, one hundred, more than one hundred, or N bytes in size. One particular example of this cryptographic split process, or cryptosplit, would be to consider the data to be 23 bytes in size, with the data unit size chosen to be one byte, and with the number of shares selected to be 4. Each byte would be distributed into one of the 4 shares. Assuming a random distribution, a key would be obtained to create a sequence of 23 random numbers (r_1, r_2, r_3 through r_{23}), each with a value between 1 and 4 corresponding to the four shares. Each of the units of data (in this example 23 individual bytes of data) is associated with one of the 23 random numbers corresponding to one of the four shares. The distribution of the bytes of data into the four shares would occur by placing the first byte of the data into share number r_1 , byte two into share r_2 , byte three into share r_3 , through the 23rd byte of data into share r_{23} . It is readily

apparent to those of ordinary skill in the art that a wide variety of other possible steps or combination or sequence of steps, including the size of the data units, may be used in the cryptosplit process of the present invention, and the above example is a non-limiting description of one process for cryptosplitting data. To recreate the original data, the reverse operation would be performed.

[0281] In another embodiment of the cryptosplit process of the present invention, an option for the cryptosplitting process is to provide sufficient redundancy in the shares such that only a subset of the shares are needed to reassemble or restore the data to its original or useable form. As a non-limiting example, the cryptosplit may be done as a "3 of 4" cryptosplit such that only three of the four shares are necessary to reassemble or restore the data to its original or useable form. This is also referred to as a "M of N cryptosplit" wherein N is the total number of shares, and M is at least one less than N. It is readily apparent to those of ordinary skill in the art that there are many possibilities for creating this redundancy in the cryptosplitting process of the present invention.

[0282] In one embodiment of the cryptosplitting process of the present invention, each unit of data is stored in two shares, the primary share and the backup share. Using the "3 of 4" cryptosplitting process described above, any one share can be missing, and this is sufficient to reassemble or restore the original data with no missing data units since only three of the total four shares are required. As described herein, a random number is generated that corresponds to one of the shares. The random number is associated with a data unit, and stored in the corresponding share, based on a key. One key is used, in this embodiment, to generate the primary and backup share random number. As described herein for the cryptosplitting process of the present invention, a set of random numbers (also referred to as primary share numbers) from 0 to 3 are generated equal to the number of data units. Then another set of random numbers is generated (also referred to as backup share numbers) from 1 to 3 equal to the number of data units. Each unit of data is then associated with a primary share number and a backup share number. Alternatively, a set of random numbers may be generated that is fewer than the number of data units, and repeating the random number set, but this may reduce the security of the sensitive data. The primary share number is used to determine into which share the data unit is stored. The backup share number is combined with the primary share number to create a third share number between 0 and 3, and this number is used to determine into which share the data unit is stored. In this example, the equation to determine the third share number is:

(primary share number + backup share number) MOD 4 = third share number.

[0283] In the embodiment described above where the primary share number is between 0 and 3, and the backup share number is between 1 and 3 ensures that the third share number is different from the primary share number. This results in the data unit being stored in two different shares. It is readily apparent to those of ordinary skill in the art that there are many ways of performing redundant cryptosplitting and non-redundant cryptosplitting in addition to the embodiments disclosed herein. For example, the data units in each share could be shuffled utilizing a different algorithm. This data unit shuffling may be performed as the original data is split into the data units, or after the data units are placed into the shares, or after the share is full, for example.

[0284] The various cryptosplitting processes and data shuffling processes described herein, and all other embodiments of the cryptosplitting and data shuffling methods of the present invention may be performed on data units of any size, including but not limited to, as small as an individual bit, bits, bytes, kilobytes, megabytes or larger.

[0285] An example of one embodiment of source code that would perform the cryptosplitting process described herein is:

DATA [1:24] – array of bytes with the data to be split

SHARES[0:3; 1:24] – 2-dimensional array with each row representing one of the shares

RANDOM[1:24] – array random numbers in the range of 0..3

S1 = 1;

S2 = 1;

S3 = 1;

S4 = 1;

For J = 1 to 24 do

 Begin

 IF RANDOM[J] == 0 then

 Begin

 SHARES[1,S1] = DATA [J];

 S1 = S1 + 1;

 End

 ELSE IF RANDOM[J] == 1 then

 Begin

 SHARES[2,S2] = DATA [J];

 S2 = S2 + 1;

```

        END
    ELSE IF RANDOM[J] == 2 then
        Begin
            Shares[3,S3] = data [J];
            S3 = S3 + 1;
        End
    Else begin
            Shares[4,S4] = data [J];
            S4 = S4 + 1;
        End;
    END;

```

[0286] An example of one embodiment of source code that would perform the cryptosplitting RAID process described herein is:

[0287] Generate two sets of numbers, PrimaryShare is 0 to 3, BackupShare is 1 to 3. Then put each data unit into share[primaryshare[1]] and share[(primaryshare[1]+backupshare[1]) mod 4, with the same process as in cryptosplitting described above. This method will be scalable to any size N, where only N-1 shares are necessary to restore the data.

[0288] The retrieval, recombining, reassembly or reconstituting of the encrypted data elements may utilize any number of authentication techniques, including, but not limited to, biometrics, such as fingerprint recognition, facial scan, hand scan, iris scan, retinal scan, ear scan, vascular pattern recognition or DNA analysis. The data splitting and/or parser modules of the present invention may be integrated into a wide variety of infrastructure products or applications as desired.

[0289] Traditional encryption technologies known in the art rely on one or more key used to encrypt the data and render it unusable without the key. The data, however, remains whole and intact and subject to attack. The secure data parser of the present invention, in one embodiment, addresses this problem by performing a cryptographic parsing and splitting of the encrypted file into two or more portions or shares, and in another embodiment, preferably four or more shares, adding another layer of encryption to each share of the data, then storing the shares in different physical and/or logical locations. When one or more data shares are physically removed from the system, either by using a removable device, such as a data storage device, or by placing the share under another party's control, any possibility of compromise of secured data is effectively removed.

[0290] An example of one embodiment of the secure data parser of the present invention and an example of how it may be utilized is shown in FIGURE 21 and described below. However, it is readily apparent to those of ordinary skill in the art that the secure data parser of the present invention may be utilized in a wide variety of ways in addition to the non-limiting example below. As a deployment option, and in one embodiment, the secure data parser may be implemented with external session key management or secure internal storage of session keys. Upon implementation, a Parser Master Key will be generated which will be used for securing the application and for encryption purposes. It should be also noted that the incorporation of the Parser Master key in the resulting secured data allows for a flexibility of sharing of secured data by individuals within a workgroup, enterprise or extended audience.

[0291] As shown in Figure 21, this embodiment of the present invention shows the steps of the process performed by the secure data parser on data to store the session master key with the parsed data:

[0292] 1. Generating a session master key and encrypt the data using RS1 stream cipher.

[0293] 2. Separating the resulting encrypted data into four shares or portions of parsed data according to the pattern of the session master key.

[0294] 3. In this embodiment of the method, the session master key will be stored along with the secured data shares in a data depository. Separating the session master key according to the pattern of the Parser Master Key and append the key data to the encrypted parsed data.

[0295] 4. The resulting four shares of data will contain encrypted portions of the original data and portions of the session master key. Generate a stream cipher key for each of the four data shares.

[0296] 5. Encrypting each share, then store the encryption keys in different locations from the encrypted data portions or shares: Share 1 gets Key 4, Share 2 gets Key 1, Share 3 gets Key 2, Share 4 gets Key 3.

[0297] To restore the original data format, the steps are reversed.

[0298] It is readily apparent to those of ordinary skill in the art that certain steps of the methods described herein may be performed in different order, or repeated multiple times, as desired. It is also readily apparent to those skilled in the art that the portions of the data may be handled differently from one another. For example, multiple parsing steps may be performed on only one portion of the parsed data. Each portion of parsed data may be uniquely secured in any desirable way provided only that the data may be reassembled, reconstituted, reformed, decrypted or restored to its original or other usable form.

[0299] As shown in FIGURE 22 and described herein, another embodiment of the present invention comprises the steps of the process performed by the secure data parser on data to store the session master key data in one or more separate key management table:

[0300] 1. Generating a session master key and encrypt the data using RS1 stream cipher.

[0301] 2. Separating the resulting encrypted data into four shares or portions of parsed data according to the pattern of the session master key.

[0302] 3. In this embodiment of the method of the present invention, the session master key will be stored in a separate key management table in a data depository. Generating a unique transaction ID for this transaction. Storing the transaction ID and session master key in a separate key management table. Separating the transaction ID according to the pattern of the Parser Master Key and append the data to the encrypted parsed or separated data.

[0303] 4. The resulting four shares of data will contain encrypted portions of the original data and portions of the transaction ID.

[0304] 5. Generating a stream cipher key for each of the four data shares.

[0305] 6. Encrypting each share, then store the encryption keys in different locations from the encrypted data portions or shares: Share 1 gets Key 4, Share 2 gets Key 1, Share 3 gets Key 2, Share 4 gets Key 3.

[0306] To restore the original data format, the steps are reversed.

[0307] It is readily apparent to those of ordinary skill in the art that certain steps of the method described herein may be performed in different order, or repeated multiple times, as desired. It is also readily apparent to those skilled in the art that the portions of the data may be handled differently from one another. For example, multiple separating or parsing steps may be performed on only one portion of the parsed data. Each portion of parsed data may be uniquely secured in any desirable way provided only that the data may be reassembled, reconstituted, reformed, decrypted or restored to its original or other usable form.

[0308] As shown in Figure 23, this embodiment of the present invention shows the steps of the process performed by the secure data parser on data to store the session master key with the parsed data:

[0309] 1. Accessing the parser master key associated with the authenticated user

[0310] 2. Generating a unique Session Master key

[0311] 3. Derive an Intermediary Key from an exclusive OR function of the Parser Master Key and Session Master key

[0312] 4. Optional encryption of the data using an existing or new encryption algorithm keyed with the Intermediary Key.

- [0313]** 5. Separating the resulting optionally encrypted data into four shares or portions of parsed data according to the pattern of the Intermediary key.
- [0314]** 6. In this embodiment of the method, the session master key will be stored along with the secured data shares in a data depository. Separating the session master key according to the pattern of the Parser Master Key and append the key data to the optionally encrypted parsed data shares.
- [0315]** 7. The resulting multiple shares of data will contain optionally encrypted portions of the original data and portions of the session master key.
- [0316]** 8. Optionally generate an encryption key for each of the four data shares.
- [0317]** 9. Optionally encrypting each share with an existing or new encryption algorithm, then store the encryption keys in different locations from the encrypted data portions or shares: for example, Share 1 gets Key 4, Share 2 gets Key 1, Share 3 gets Key 2, Share 4 gets Key 3.
- [0318]** To restore the original data format, the steps are reversed.
- [0319]** It is readily apparent to those of ordinary skill in the art that certain steps of the methods described herein may be performed in different order, or repeated multiple times, as desired. It is also readily apparent to those skilled in the art that the portions of the data may be handled differently from one another. For example, multiple parsing steps may be performed on only one portion of the parsed data. Each portion of parsed data may be uniquely secured in any desirable way provided only that the data may be reassembled, reconstituted, reformed, decrypted or restored to its original or other usable form.
- [0320]** As shown in FIGURE 24 and described herein, another embodiment of the present invention comprises the steps of the process performed by the secure data parser on data to store the session master key data in one or more separate key management table:
- [0321]** 1. Accessing the Parser Master Key associated with the authenticated user
- [0322]** 2. Generating a unique Session Master Key
- [0323]** 3. Derive an Intermediary Key from an exclusive OR function of the Parser Master Key and Session Master key
- [0324]** 4. Optionally encrypt the data using an existing or new encryption algorithm keyed with the Intermediary Key.
- [0325]** 5. Separating the resulting optionally encrypted data into four shares or portions of parsed data according to the pattern of the Intermediary Key.
- [0326]** 6. In this embodiment of the method of the present invention, the session master key will be stored in a separate key management table in a data depository. Generating a

unique transaction ID for this transaction. Storing the transaction ID and session master key in a separate key management table or passing the Session Master Key and transaction ID back to the calling program for external management. Separating the transaction ID according to the pattern of the Parser Master Key and append the data to the optionally encrypted parsed or separated data.

[0327] 7. The resulting four shares of data will contain optionally encrypted portions of the original data and portions of the transaction ID.

[0328] 8. Optionally generate an encryption key for each of the four data shares.

[0329] 9. Optionally encrypting each share, then store the encryption keys in different locations from the encrypted data portions or shares. For example: Share 1 gets Key 4, Share 2 gets Key 1, Share 3 gets Key 2, Share 4 gets Key 3.

[0330] To restore the original data format, the steps are reversed.

[0331] It is readily apparent to those of ordinary skill in the art that certain steps of the method described herein may be performed in different order, or repeated multiple times, as desired. It is also readily apparent to those skilled in the art that the portions of the data may be handled differently from one another. For example, multiple separating or parsing steps may be performed on only one portion of the parsed data. Each portion of parsed data may be uniquely secured in any desirable way provided only that the data may be reassembled, reconstituted, reformed, decrypted or restored to its original or other usable form.

[0332] A wide variety of encryption methodologies are suitable for use in the methods of the present invention, as is readily apparent to those skilled in the art. The One Time Pad algorithm, is often considered one of the most secure encryption methods, and is suitable for use in the method of the present invention. Using the One Time Pad algorithm requires that a key be generated which is as long as the data to be secured. The use of this method may be less desirable in certain circumstances such as those resulting in the generation and management of very long keys because of the size of the data set to be secured. In the One-Time Pad (OTP) algorithm, the simple exclusive-or function, XOR, is used. For two binary streams x and y of the same length, x XOR y means the bitwise exclusive-or of x and y .

[0333] At the bit level is generated:

$0 \text{ XOR } 0 = 0$

$0 \text{ XOR } 1 = 1$

$1 \text{ XOR } 0 = 1$

$1 \text{ XOR } 1 = 0$

[0334] An example of this process is described herein for an n-byte secret, s, (or data set) to be split. The process will generate an n-byte random value, a, and then set:

$$b = a \text{ XOR } s.$$

[0335] Note that one can derive "s" via the equation:

$$s = a \text{ XOR } b.$$

[0336] The values a and b are referred to as shares or portions and are placed in separate depositories. Once the secret s is split into two or more shares, it is discarded in a secure manner.

[0337] The secure data parser of the present invention may utilize this function, performing multiple XOR functions incorporating multiple distinct secret key values: K1, K2, K3, Kn, K5. At the beginning of the operation, the data to be secured is passed through the first encryption operation, secure data = data XOR secret key 5:

$$S = D \text{ XOR } K5$$

[0338] In order to securely store the resulting encrypted data in, for example, four shares, S1, S2, S3, Sn, the data is parsed and split into "n" segments, or shares, according to the value of K5. This operation results in "n" pseudorandom shares of the original encrypted data.

Subsequent XOR functions may then be performed on each share with the remaining secret key values, for example: Secure data segment 1 = encrypted data share 1 XOR secret key 1:

$$SD1 = S1 \text{ XOR } K1$$

$$SD2 = S2 \text{ XOR } K2$$

$$SD3 = S3 \text{ XOR } K3$$

$$SDn = Sn \text{ XOR } Kn.$$

[0339] In one embodiment, it may not be desired to have any one depository contain enough information to decrypt the information held there, so the key required to decrypt the share is stored in a different data depository:

Depository 1: SD1, Kn

Depository 2: SD2, K1

Depository 3: SD3, K2

Depository n: SDn, K3.

[0340] Additionally, appended to each share may be the information required to retrieve the original session encryption key, K5. Therefore, in the key management example described herein, the original session master key is referenced by a transaction ID split into "n" shares according to the contents of the installation dependant Parser Master Key (TID1, TID2, TID3, TIDn):

Depository 1: SD1, Kn, TID1

Depository 2: SD2, K1, TID2

Depository 3: SD3, K2, TID3

Depository n: SDn, K3, TIDn.

[0341] In the incorporated session key example described herein, the session master key is split into "n" shares according to the contents of the installation dependant Parser Master Key (SK1, SK2, SK3, SKn):

Depository 1: SD1, Kn, SK1

Depository 2: SD2, K1, SK2

Depository 3: SD3, K2, SK3

Depository n: SDn, K3, SKn.

[0342] Unless all four shares are retrieved, the data cannot be reassembled according to this example. Even if all four shares are captured, there is no possibility of reassembling or restoring the original information without access to the session master key and the Parser Master Key.

[0343] This example has described an embodiment of the method of the present invention, and also describes, in another embodiment, the algorithm used to place shares into depositories so that shares from all depositories can be combined to form the secret authentication material. The computations needed are very simple and fast. However, with the One Time Pad (OTP) algorithm there may be circumstances that cause it to be less desirable, such as a large data set to be secured, because the key size is the same size as the data to be stored. Therefore, there would be a need to store and transmit about twice the amount of the original data which may be less desirable under certain circumstances.

Stream Cipher RS1

[0344] The stream cipher RS1 splitting technique is very similar to the OTP splitting technique described herein. Instead of an n-byte random value, an $n' = \min(n, 16)$ -byte random value is generated and used to key the RS1 Stream Cipher algorithm. The advantage of the RS1 Stream Cipher algorithm is that a pseudorandom key is generated from a much smaller seed number. The speed of execution of the RS1 Stream Cipher encryption is also rated at approximately 10 times the speed of the well known in the art Triple Data Encryption Standard ("Triple DES" or "3DES") encryption without compromising security. The RS1 Stream Cipher algorithm is well known in the art, and may be used to generate the keys used in the XOR function. The RS1 Stream Cipher algorithm is interoperable with other

commercially available stream cipher algorithms, such as the RC4™ stream cipher algorithm of RSA Security, Inc and is suitable for use in the methods of the present invention.

[0345] Using the key notation above, K1 thru K5 are now an n' byte random values and we set:

$$SD1 = S1 \text{ XOR } E(K1)$$

$$SD2 = S2 \text{ XOR } E(K2)$$

$$SD3 = S3 \text{ XOR } E(K3)$$

$$SDn = Sn \text{ XOR } E(Kn)$$

where E(K1) thru E(Kn) are the first n' bytes of output from the RS1 Stream Cipher algorithm keyed by K1 thru Kn. The shares are now placed into data depositories as described herein.

[0346] In this stream cipher RS1 algorithm, the required computations needed are nearly as simple and fast as the OTP algorithm. The benefit in this example using the RS1 Stream Cipher is that the system needs to store and transmit on average only about 16 bytes more than the size of the original data to be secured per share. When the size of the original data is more than 16 bytes, this RS1 algorithm is more efficient than the OTP algorithm because it is simply shorter. It is readily apparent to those of ordinary skill in the art that a wide variety of encryption methods or algorithms are suitable for use in the present invention, including, but not limited to RS1, OTP, RC4™, Triple DES, and the Advanced Encryption Standard (“AES”).

[0347] There are major advantages provided by the data security methods and computer systems of the present invention over traditional encryption methods. One advantage is the security gained from moving shares of the data to different locations on one or more data depositories or storage devices, that may be in different logical, physical or geographical locations. When the shares of data are split physically and under the control of different personnel, for example, the possibility of compromising the data is greatly reduced.

[0348] Another advantage provided by the methods and system of the present invention is the combination of the steps of the method of the present invention for securing data to provide a comprehensive process of maintaining security of sensitive data. The data is encrypted with a secure key and split into one or more shares, and in one embodiment, four shares, according to the secure key. The secure key is stored safely with a reference pointer which is secured into four shares according to a secure key. The data shares are then encrypted individually and the keys are stored safely with different encrypted shares. When combined, the entire process for securing data according to the methods disclosed herein becomes a comprehensive package for data security.

[0349] The data secured according to the methods of the present invention is readily retrievable and restored, reconstituted, reassembled, decrypted, or otherwise returned into its original or other suitable form for use. In order to restore the original data, the following items may be utilized:

[0350] 1. All shares or portions of the data set.

[0351] 2. Knowledge of and ability to reproduce the process flow of the method used to secure the data.

[0352] 3. Access to the session master key.

[0353] 4. Access to the Parser Master Key.

[0354] Therefore, it may be desirable to plan a secure installation wherein at least one of the above elements may be physically separated from the remaining components of the system (under the control of a different system administrator for example).

[0355] Protection against a rogue application invoking the data securing methods application may be enforced by use of the Parser Master Key. A mutual authentication handshake between the secure data parser and the application may be required in this embodiment of the present invention prior to any action taken.

[0356] The security of the system dictates that there be no "backdoor" method for recreation of the original data. For installations where data recovery issues may arise, the secure data parser can be enhanced to provide a mirror of the four shares and session master key depository. Hardware options such as RAID (redundant array of inexpensive disks, used to spread information over several disks) and software options such as replication can assist as well in the data recovery planning.

Key Management

[0357] In one embodiment of the present invention, the data securing method uses three sets of keys for an encryption operation. Each set of keys may have individual key storage, retrieval, security and recovery options, based on the installation. The keys that may be used, include, but are not limited to:

The Parser Master Key

[0358] This key is an individual key associated with the installation of the secure data parser. It is installed on the server on which the secure data parser has been deployed. There are a variety of options suitable for securing this key including, but not limited to, a smart card, separate hardware key store, standard key stores, custom key stores or within a secured database table, for example.

The Session Master Key

[0359] A Session Master Key may be generated each time data is secured. The Session Master Key is used to encrypt the data prior to the parsing and splitting operations. It may also be incorporated (if the Session Master Key is not integrated into the parsed data) as a means of parsing the encrypted data. The Session Master Key may be secured in a variety of manners, including, but not limited to, a standard key store, custom key store, separate database table, or secured within the encrypted shares, for example.

The Share Encryption Keys

[0360] For each share or portions of a data set that is created, an individual Share Encryption Key may be generated to further encrypt the shares. The Share Encryption Keys may be stored in different shares than the share that was encrypted.

[0361] It is readily apparent to those of ordinary skill in the art that the data securing methods and computer system of the present invention are widely applicable to any type of data in any setting or environment. In addition to commercial applications conducted over the Internet or between customers and vendors, the data securing methods and computer systems of the present invention are highly applicable to non-commercial or private settings or environments. Any data set that is desired to be kept secure from any unauthorized user may be secured using the methods and systems described herein. For example, access to a particular database within a company or organization may be advantageously restricted to only selected users by employing the methods and systems of the present invention for securing data. Another example is the generation, modification or access to documents wherein it is desired to restrict access or prevent unauthorized or accidental access or disclosure outside a group of selected individuals, computers or workstations. These and other examples of the ways in which the methods and systems of data securing of the present invention are applicable to any non-commercial or commercial environment or setting for any setting, including, but not limited to any organization, government agency or corporation.

[0362] In another embodiment of the present invention, the data securing method uses three sets of keys for an encryption operation. Each set of keys may have individual key storage, retrieval, security and recovery options, based on the installation. The keys that may be used, include, but are not limited to:

1. The Parser Master Key

[0363] This key is an individual key associated with the installation of the secure data parser. It is installed on the server on which the secure data parser has been deployed. There are a variety of options suitable for securing this key including, but not limited to, a smart

card, separate hardware key store, standard key stores, custom key stores or within a secured database table, for example.

2. The Session Master Key

[0364] A Session Master Key may be generated each time data is secured. The Session Master Key is used in conjunction with the Parser Master key to derive the Intermediary Key. The Session Master Key may be secured in a variety of manners, including, but not limited to, a standard key store, custom key store, separate database table, or secured within the encrypted shares, for example.

3. The Intermediary Key

[0365] An Intermediary Key may be generated each time data is secured. The Intermediary Key is used to encrypt the data prior to the parsing and splitting operation. It may also be incorporated as a means of parsing the encrypted data.

4. The Share Encryption Keys

[0366] For each share or portions of a data set that is created, an individual Share Encryption Key may be generated to further encrypt the shares. The Share Encryption Keys may be stored in different shares than the share that was encrypted.

[0367] It is readily apparent to those of ordinary skill in the art that the data securing methods and computer system of the present invention are widely applicable to any type of data in any setting or environment. In addition to commercial applications conducted over the Internet or between customers and vendors, the data securing methods and computer systems of the present invention are highly applicable to non-commercial or private settings or environments. Any data set that is desired to be kept secure from any unauthorized user may be secured using the methods and systems described herein. For example, access to a particular database within a company or organization may be advantageously restricted to only selected users by employing the methods and systems of the present invention for securing data. Another example is the generation, modification or access to documents wherein it is desired to restrict access or prevent unauthorized or accidental access or disclosure outside a group of selected individuals, computers or workstations. These and other examples of the ways in which the methods and systems of data securing of the present invention are applicable to any non-commercial or commercial environment or setting for any setting, including, but not limited to any organization, government agency or corporation.

Workgroup, Project, Individual PC/Laptop or Cross Platform Data Security

[0368] The data securing methods and computer systems of the present invention are also useful in securing data by workgroup, project, individual PC/Laptop and any other platform

that is in use in, for example, businesses, offices, government agencies, or any setting in which sensitive data is created, handled or stored. The present invention provides methods and computer systems to secure data that is known to be sought after by organizations, such as the U.S. Government, for implementation across the entire government organization or between governments at a state or federal level.

[0369] The data securing methods and computer systems of the present invention provide the ability to not only parse and split flat files but also data fields, sets and or table of any type. Additionally, all forms of data are capable of being secured under this process, including, but not limited to, text, video, images, biometrics and voice data. Scalability, speed and data throughput of the methods of securing data of the present invention are only limited to the hardware the user has at their disposal.

[0370] In one embodiment of the present invention, the data securing methods are utilized as described below in a workgroup environment. In one embodiment, as shown in FIGURE 23 and described below, the Workgroup Scale data securing method of the present invention uses the private key management functionality of the TrustEngine to store the user/group relationships and the associated private keys (Parser Group Master Keys) necessary for a group of users to share secure data. The method of the present invention has the capability to secure data for an enterprise, workgroup, or individual user, depending on how the Parser Master Key was deployed.

[0371] In one embodiment, additional key management and user/group management programs may be provided, enabling wide scale workgroup implementation with a single point of administration and key management. Key generation, management and revocation are handled by the single maintenance program, which all become especially important as the number of users increase. In another embodiment, key management may also be set up across one or several different system administrators, which may not allow any one person or group to control data as needed. This allows for the management of secured data to be obtained by roles, responsibilities, membership, rights, etc., as defined by an organization, and the access to secured data can be limited to just those who are permitted or required to have access only to the portion they are working on, while others, such as managers or executives, may have access to all of the secured data. This embodiment allows for the sharing of secured data among different groups within a company or organization while at the same time only allowing certain selected individuals, such as those with the authorized and predetermined roles and responsibilities, to observe the data as a whole. In addition, this embodiment of the methods and systems of the present invention also allows for the sharing of data among, for

example, separate companies, or separate departments or divisions of companies, or any separate organization departments, groups, agencies, or offices, or the like, of any government or organization or any kind, where some sharing is required, but not any one party may be permitted to have access to all the data. Particularly apparent examples of the need and utility for such a method and system of the present invention are to allow sharing, but maintain security, in between government areas, agencies and offices, and between different divisions, departments or offices of a large company, or any other organization, for example.

[0372] An example of the applicability of the methods of the present invention on a smaller scale is as follows. A Parser Master key is used as a serialization or branding of the secure data parser to an organization. As the scale of use of the Parser Master key is reduced from the whole enterprise to a smaller workgroup, the data securing methods described herein are used to share files within groups of users.

[0373] In the example shown in FIGURE 25 and described below, there are six users defined along with their title or role within the organization. The side bar represents five possible groups that the users can belong to according to their role. The arrow represents membership by the user in one or more of the groups.

[0374] When configuring the secure data parser for use in this example, the system administrator accesses the user and group information from the operating system by a maintenance program. This maintenance program generates and assigns Parser Group Master Keys to users based on their membership in groups.

[0375] In this example, there are three members in the Senior Staff group. For this group, the actions would be:

[0376] 1. Access Parser Group Master Key for the Senior Staff group (generate a key if not available);

[0377] 2. Generate a digital certificate associating CEO with the Senior Staff group;

[0378] 3. Generate a digital certificate associating CFO with the Senior Staff group;

[0379] 4. Generate a digital certificate associating Vice President, Marketing with the Senior Staff group.

[0380] The same set of actions would be done for each group, and each member within each group. When the maintenance program is complete, the Parser Group Master Key becomes a shared credential for each member of the group. Revocation of the assigned digital certificate may be done automatically when a user is removed from a group through the maintenance program without affecting the remaining members of the group.

[0381] Once the shared credentials have been defined, the parsing and splitting process remains the same. When a file, document or data element is to be secured, the user is prompted for the target group to be used when securing the data. The resulting secured data is only accessible by other members of the target group. This functionality of the methods and systems of the present invention may be used with any other computer system or software platform, any may be, for example, integrated into existing application programs or used standalone for file security.

[0382] It is readily apparent to those of ordinary skill in the art that any one or combination of encryption algorithms are suitable for use in the methods and systems of the present invention. For example, the encryption steps may, in one embodiment, be repeated to produce a multi-layered encryption scheme. In addition, a different encryption algorithm, or combination of encryption algorithms, may be used in repeat encryption steps such that different encryption algorithms are applied to the different layers of the multi-layered encryption scheme. As such, the encryption scheme itself may become a component of the methods of the present invention for securing sensitive data from unauthorized use or access.

[0383] The secure data parser may include as an internal component, as an external component, or as both an error-checking component. For example, in one suitable approach, as portions of data are created using the secure data parser in accordance with the present invention, to assure the integrity of the data within a portion, a hash value is taken at preset intervals within the portion and is appended to the end of the interval. The hash value is a predictable and reproducible numeric representation of the data. If any bit within the data changes, the hash value would be different. A scanning module (either as a stand-alone component external to the secure data parser or as an internal component) may then scan the portions of data generated by the secure data parser. Each portion of data (or alternatively, less than all portions of data according to some interval or by a random or pseudo-random sampling) is compared to the appended hash value or values and an action may be taken. This action may include a report of values that match and do not match, an alert for values that do not match, or invoking of some external or internal program to trigger a recovery of the data. For example, recovery of the data could be performed by invoking a recovery module based on the concept that fewer than all portions may be needed to generate original data in accordance with the present invention.

[0384] Any other suitable integrity checking may be implemented using any suitable integrity information appended anywhere in all or a subset of data portions. Integrity information may include any suitable information that can be used to determine the integrity

of data portions. Examples of integrity information may include hash values computed based on any suitable parameter (e.g., based on respective data portions), digital signature information, message authentication code (MAC) information, any other suitable information, or any combination thereof.

[0385] The secure data parser of the present invention may be used in any suitable application. Namely, the secure data parser described herein has a variety of applications in different areas of computing and technology. Several such areas are discussed below. It will be understood that these are merely illustrative in nature and that any other suitable applications may make use of the secure data parser. It will further be understood that the examples described are merely illustrative embodiments that may be modified in any suitable way in order to satisfy any suitable desires. For example, parsing and splitting may be based on any suitable units, such as by bits, by bytes, by kilobytes, by megabytes, by any combination thereof, or by any other suitable unit.

[0386] The secure data parser of the present invention may be used to implement secure physical tokens, whereby data stored in a physical token may be required in order to access additional data stored in another storage area. In one suitable approach, a physical token, such as a compact USB flash drive, a floppy disk, an optical disk, a smart card, or any other suitable physical token, may be used to store one of at least two portions of parsed data in accordance with the present invention. In order to access the original data, the USB flash drive would need to be accessed. Thus, a personal computer holding one portion of parsed data would need to have the USB flash drive, having the other portion of parsed data, attached before the original data can be accessed. FIGURE 26 illustrates this application. Storage area 2500 includes a portion of parsed data 2502. Physical token 2504, having a portion of parsed data 2506 would need to be coupled to storage area 2500 using any suitable communications interface 2508 (e.g., USB, serial, parallel, Bluetooth, IR, IEEE 1394, Ethernet, or any other suitable communications interface) in order to access the original data. This is useful in a situation where, for example, sensitive data on a computer is left alone and subject to unauthorized access attempts. By removing the physical token (e.g., the USB flash drive), the sensitive data is inaccessible. It will be understood that any other suitable approach for using physical tokens may be used.

[0387] The secure data parser of the present invention may be used to implement a secure authentication system whereby user enrollment data (e.g., passwords, private encryption keys, fingerprint templates, biometric data or any other suitable user enrollment data) is parsed and split using the secure data parser. The user enrollment data may be parsed and split whereby

one or more portions are stored on a smart card, a government Common Access Card, any suitable physical storage device (e.g., magnetic or optical disk, USB key drive, etc.), or any other suitable device. One or more other portions of the parsed user enrollment data may be stored in the system performing the authentication. This provides an added level of security to the authentication process (e.g., in addition to the biometric authentication information obtained from the biometric source, the user enrollment data must also be obtained via the appropriate parsed and split data portion).

[0388] The secure data parser of the present invention may be integrated into any suitable existing system in order to provide the use of its functionality in each system's respective environment. FIGURE 27 shows a block diagram of an illustrative system 2600, which may include software, hardware, or both for implementing any suitable application. System 2600 may be an existing system in which secure data parser 2602 may be retrofitted as an integrated component. Alternatively, secure data parser 2602 may be integrated into any suitable system 2600 from, for example, its earliest design stage. Secure data parser 2600 may be integrated at any suitable level of system 2600. For example, secure data parser 2602 may be integrated into system 2600 at a sufficiently back-end level such that the presence of secure data parser 2602 may be substantially transparent to an end user of system 2600. Secure data parser 2602 may be used for parsing and splitting data among one or more storage devices 2604 in accordance with the present invention. Some illustrative examples of systems having the secure data parser integrated therein are discussed below.

[0389] The secure data parser of the present invention may be integrated into an operating system kernel (e.g., Linux, Unix, or any other suitable commercial or proprietary operating system). This integration may be used to protect data at the device level whereby, for example, data that would ordinarily be stored in one or more devices is separated into a certain number of portions by the secure data parser integrated into the operating system and stored among the one or more devices. When original data is attempted to be accessed, the appropriate software, also integrated into the operating system, may recombine the parsed data portions into the original data in a way that may be transparent to the end user.

[0390] The secure data parser of the present invention may be integrated into a volume manager or any other suitable component of a storage system to protect local and networked data storage across any or all supported platforms. For example, with the secure data parser integrated, a storage system may make use of the redundancy offered by the secure data parser (i.e., which is used to implement the feature of needing fewer than all separated portions of data in order to reconstruct the original data) to protect against data loss. The

secure data parser also allows all data written to storage devices, whether using redundancy or not, to be in the form of multiple portions that are generated according to the parsing of the present invention. When original data is attempted to be accessed, the appropriate software, also integrated into the volume manager or other suitable component of the storage system, may recombine the parsed data portions into the original data in a way that may be transparent to the end user.

[0391] In one suitable approach, the secure data parser of the present invention may be integrated into a RAID controller (as either hardware or software). This allows for the secure storage of data to multiple drives while maintaining fault tolerance in case of drive failure.

[0392] The secure data parser of the present invention may be integrated into a database in order to, for example, protect sensitive table information. For example, in one suitable approach, data associated with particular cells of a database table (e.g., individual cells, one or more particular columns, one or more particular rows, any combination thereof, or an entire database table) may be parsed and separated according to the present invention (e.g., where the different portions are stored on one or more storage devices at one or more locations or on a single storage device). Access to recombine the portions in order to view the original data may be granted by traditional authentication methods (e.g., username and password query).

[0393] The secure data parser of the present invention may be integrated in any suitable system that involves data in motion (i.e., transfer of data from one location to another). Such systems include, for example, email, streaming data broadcasts, and wireless (e.g., WiFi) communications. With respect to email, in one suitable approach, the secure data parser may be used to parse outgoing messages (i.e., containing text, binary data, or both (e.g., files attached to an email message)) and sending the different portions of the parsed data along different paths thus creating multiple streams of data. If any one of these streams of data is compromised, the original message remains secure because the system may require that more than one of the portions be combined, in accordance with the present invention, in order to generate the original data. In another suitable approach, the different portions of data may be communicated along one path sequentially so that if one portion is obtained, it may not be sufficient to generate the original data. The different portions arrive at the intended recipient's location and may be combined to generate the original data in accordance with the present invention.

[0394] FIGURES 28 and 29 are illustrative block diagrams of such email systems. FIGURE 28 shows a sender system 2700, which may include any suitable hardware, such as a computer terminal, personal computer, handheld device (e.g., PDA, Blackberry), cellular

telephone, computer network, any other suitable hardware, or any combination thereof. Sender system 2700 is used to generate and/or store a message 2704, which may be, for example, an email message, a binary data file (e.g., graphics, voice, video, etc.), or both. Message 2704 is parsed and split by secure data parser 2702 in accordance with the present invention. The resultant data portions may be communicated across one or more separate communications paths 2706 over network 2708 (e.g., the Internet, an intranet, a LAN, WiFi, Bluetooth, any other suitable hard-wired or wireless communications means, or any combination thereof) to recipient system 2710. The data portions may be communicated parallel in time or alternatively, according to any suitable time delay between the communication of the different data portions. Recipient system 2710 may be any suitable hardware as described above with respect to sender system 2700. The separate data portions carried along communications paths 2706 are recombined at recipient system 2710 to generate the original message or data in accordance with the present invention.

[0395] FIGURE 29 shows a sender system 2800, which may include any suitable hardware, such as a computer terminal, personal computer, handheld device (e.g., PDA), cellular telephone, computer network, any other suitable hardware, or any combination thereof. Sender system 2800 is used to generate and/or store a message 2804, which may be, for example, an email message, a binary data file (e.g., graphics, voice, video, etc.), or both. Message 2804 is parsed and split by secure data parser 2802 in accordance with the present invention. The resultant data portions may be communicated across a single communications paths 2806 over network 2808 (e.g., the Internet, an intranet, a LAN, WiFi, Bluetooth, any other suitable communications means, or any combination thereof) to recipient system 2810. The data portions may be communicated serially across communications path 2806 with respect to one another. Recipient system 2810 may be any suitable hardware as described above with respect to sender system 2800. The separate data portions carried along communications path 2806 are recombined at recipient system 2810 to generate the original message or data in accordance with the present invention.

[0396] It will be understood that the arrangement of FIGURES 28 and 29 are merely illustrative. Any other suitable arrangement may be used. For example, in another suitable approach, the features of the systems of FIGURES 28 and 29 may be combined whereby the multi-path approach of FIGURE 28 is used and in which one or more of communications paths 2706 are used to carry more than one portion of data as communications path 2806 does in the context of FIGURE 29.

[0397] The secure data parser may be integrated at any suitable level of a data-in motion system. For example, in the context of an email system, the secure data parser may be integrated at the user-interface level (e.g., into Microsoft® Outlook), in which case the user may have control over the use of the secure data parser features when using email. Alternatively, the secure data parser may be implemented in a back-end component such as at the exchange server, in which case messages may be automatically parsed, split, and communicated along different paths in accordance with the present invention without any user intervention.

[0398] Similarly, in the case of streaming broadcasts of data (e.g., audio, video), the outgoing data may be parsed and separated into multiple streams each containing a portion of the parsed data. The multiple streams may be transmitted along one or more paths and recombined at the recipient's location in accordance with the present invention. One of the benefits of this approach is that it avoids the relatively large overhead associated with traditional encryption of data followed by transmission of the encrypted data over a single communications channel. The secure data parser of the present invention allows data in motion to be sent in multiple parallel streams, increasing speed and efficiency.

[0399] It will be understood that the secure data parser may be integrated for protection of and fault tolerance of any type of data in motion through any transport medium, including, for example, wired, wireless, or physical. For example, voice over Internet protocol (VoIP) applications may make use of the secure data parser of the present invention. Wireless or wired data transport from or to any suitable personal digital assistant (PDA) devices such as Blackberries and SmartPhones may be secured using the secure data parser of the present invention. Communications using wireless 802.11 protocols for peer to peer and hub based wireless networks, satellite communications, point to point wireless communications, Internet client/server communications, or any other suitable communications may involve the data in motion capabilities of the secure data parser in accordance with the present invention. Data communication between computer peripheral device (e.g., printer, scanner, monitor, keyboard, network router, biometric authentication device (e.g., fingerprint scanner), or any other suitable peripheral device) between a computer and a computer peripheral device, between a computer peripheral device and any other suitable device, or any combination thereof may make use of the data in motion features of the present invention.

[0400] The data in motion features of the present invention may also apply to physical transportation of secure shares using for example, separate routes, vehicles, methods, any other suitable physical transportation, or any combination thereof. For example, physical

transportation of data may take place on digital/magnetic tapes, floppy disks, optical disks, physical tokens, USB drives, removable hard drives, consumer electronic devices with flash memory (e.g., Apple IPODs or other MP3 players), flash memory, any other suitable medium used for transporting data, or any combination thereof.

[0401] The secure data parser of the present invention may provide security with the ability for disaster recovery. According to the present invention, fewer than all portions of the separated data generated by the secure data parser may be necessary in order to retrieve the original data. That is, out of m portions stored, n may be the minimum number of these m portions necessary to retrieve the original data, where $n \leq m$. For example, if each of four portions is stored in a different physical location relative to the other three portions, then, if $n=2$ in this example, two of the locations may be compromised whereby data is destroyed or inaccessible, and the original data may still be retrieved from the portions in the other two locations. Any suitable value for n or m may be used.

[0402] In addition, the n of m feature of the present invention may be used to create a "two man rule" whereby in order to avoid entrusting a single individual or any other entity with full access to what may be sensitive data, two or more distinct entities, each with a portion of the separated data parsed by the secure data parser of the present invention may need to agree to put their portions together in order to retrieve the original data.

[0403] The secure data parser of the present invention may be used to provide a group of entities with a group-wide key that allows the group members to access particular information authorized to be accessed by that particular group. The group key may be one of the data portions generated by the secure data parser in accordance with the present invention that may be required to be combined with another portion centrally stored, for example in order to retrieve the information sought. This feature allows for, for example, secure collaboration among a group. It may be applied in for example, dedicated networks, virtual private networks, intranets, or any other suitable network.

[0404] Specific applications of this use of the secure data parser include, for example, coalition information sharing in which, for example, multi-national friendly government forces are given the capability to communicate operational and otherwise sensitive data on a security level authorized to each respective country over a single network or a dual network (i.e., as compared to the many networks involving relatively substantial manual processes currently used). This capability is also applicable for companies or other organizations in which information needed to be known by one or more specific individuals (within the

organization or without) may be communicated over a single network without the need to worry about unauthorized individuals viewing the information.

[0405] Another specific application includes a multi-level security hierarchy for government systems. That is, the secure data parser of the present invention may provide for the ability to operate a government system at different levels of classified information (e.g., unclassified, classified, secret, top secret) using a single network. If desired, more networks may be used (e.g., a separate network for top secret), but the present invention allows for substantially fewer than current arrangement in which a separate network is used for each level of classification.

[0406] It will be understood that any combination of the above described applications of the secure data parser of the present invention may be used. For example, the group key application can be used together with the data in motion security application (i.e., whereby data that is communicated over a network can only be accessed by a member of the respective group and where, while the data is in motion, it is split among multiple paths (or sent in sequential portions) in accordance with the present invention).

[0407] The secure data parser of the present invention may be integrated into any middleware application to enable applications to securely store data to different database products or to different devices without modification to either the applications or the database. Middleware is a general term for any product that allows two separate and already existing programs to communicate. For example, in one suitable approach, middleware having the secure data parser integrated, may be used to allow programs written for a particular database to communicate with other databases without custom coding.

[0408] The secure data parser of the present invention may be implemented having any combination of any suitable capabilities, such as those discussed herein. In some embodiments of the present invention, for example, the secure data parser may be implemented having only certain capabilities whereas other capabilities may be obtained through the use of external software, hardware, or both interfaced either directly or indirectly with the secure data parser.

[0409] FIGURE 30, for example, shows an illustrative implementation of the secure data parser as secure data parser 3000. Secure data parser 3000 may be implemented with very few built-in capabilities. As illustrated, secure data parser 3000 may include built-in capabilities for parsing and splitting data into portions (also referred to herein as shares) of data using module 3002 in accordance with the present invention. Secure data parser 3000 may also include built in capabilities for performing redundancy in order to be able to

implement, for example, the m of n feature described above (i.e., recreating the original data using fewer than all shares of parsed and split data) using module 3004. Secure data parser 3000 may also include share distribution capabilities using module 3006 for placing the shares of data into buffers from which they are sent for communication to a remote location, for storage, etc. in accordance with the present invention. It will be understood that any other suitable capabilities may be built into secure data parser 3000.

[0410] Assembled data buffer 3008 may be any suitable memory used to store the original data (although not necessarily in its original form) that will be parsed and split by secure data parser 3000. In a splitting operation, assembled data buffer 3008 provides input to secure data parser 3008. In a restore operation, assembled data buffer 3008 may be used to store the output of secure data parser 3000.

[0411] Split shares buffers 3010 may be one or more memory modules that may be used to store the multiple shares of data that resulted from the parsing and splitting of original data. In a splitting operation, split shares buffers 3010 hold the output of the secure data parser. In a restore operation, split shares buffers hold the input to secure data parser 3000.

[0412] It will be understood that any other suitable arrangement of capabilities may be built-in for secure data parser 3000. Any additional features may be built-in and any of the features illustrated may be removed, made more robust, made less robust, or may otherwise be modified in any suitable way. Buffers 3008 and 3010 are likewise merely illustrative and may be modified, removed, or added to in any suitable way.

[0413] Any suitable modules implemented in software, hardware or both may be called by or may call to secure data parser 3000. If desired, even capabilities that are built into secure data parser 3000 may be replaced by one or more external modules. As illustrated, some external modules include random number generator 3012, cipher feedback key generator 3014, hash algorithm 3016, any one or more types of encryption 3018, and key management 3020. It will be understood that these are merely illustrative external modules. Any other suitable modules may be used in addition to or in place of those illustrated.

[0414] Cipher feedback key generator 3014 may, externally to secure data parser 3000, generate for each secure data parser operation, a unique key, or random number (using, for example, random number generator 3012), to be used as a seed value for an operation that extends an original session key size (e.g., a value of 128, 256, 512, or 1024 bits) into a value equal to the length of the data to be parsed and split. Any suitable algorithm may be used for the cipher feedback key generation, including, for example, the AES cipher feedback key generation algorithm.

[0415] In order to facilitate integration of secure data parser 3000 and its external modules (i.e., secure data parser layer 3026) into an application layer 3024 (e.g., email application, database application, etc.), a wrapping layer that may make use of, for example, API function calls may be used. Any other suitable arrangement for facilitating integration of secure data parser layer 3026 into application layer 3024 may be used.

[0416] FIGURE 31 illustratively shows how the arrangement of FIGURE 30 may be used when a write (e.g., to a storage device), insert (e.g., in a database field), or transmit (e.g., across a network) command is issued in application layer 3024. At step 3100 data to be secured is identified and a call is made to the secure data parser. The call is passed through wrapper layer 3022 where at step 3102, wrapper layer 3022 streams the input data identified at step 3100 into assembled data buffer 3008. Also at step 3102, any suitable share information, filenames, any other suitable information, or any combination thereof may be stored (e.g., as information 3106 at wrapper layer 3022). Secure data processor 3000 then parses and splits the data it takes as input from assembled data buffer 3008 in accordance with the present invention. It outputs the data shares into split shares buffers 3010. At step 3104, wrapper layer 3022 obtains from stored information 3106 any suitable share information (i.e., stored by wrapper 3022 at step 3102) and share location(s) (e.g., from one or more configuration files). Wrapper layer 3022 then writes the output shares (obtained from split shares buffers 3010) appropriately (e.g., written to one or more storage devices, communicated onto a network, etc.).

[0417] FIGURE 32 illustratively shows how the arrangement of FIGURE 30 may be used when a read (e.g., from a storage device), select (e.g., from a database field), or receive (e.g., from a network) occurs. At step 3200, data to be restored is identified and a call to secure data parser 3000 is made from application layer 3024. At step 3202, from wrapper layer 3022, any suitable share information is obtained and share location is determined. Wrapper layer 3022 loads the portions of data identified at step 3200 into split shares buffers 3010. Secure data parser 3000 then processes these shares in accordance with the present invention (e.g., if only three of four shares are available, then the redundancy capabilities of secure data parser 3000 may be used to restore the original data using only the three shares). The restored data is then stored in assembled data buffer 3008. At step 3204, application layer 3022 converts the data stored in assembled data buffer 3008 into its original data format (if necessary) and provides the original data in its original format to application layer 3024.

[0418] It will be understood that the parsing and splitting of original data illustrated in FIGURE 31 and the restoring of portions of data into original data illustrated in FIGURE 32 is merely illustrative. Any other suitable processes, components, or both may be used in addition to or in place of those illustrated.

[0419] FIGURE 33 is a block diagram of an illustrative process flow for parsing and splitting original data into two or more portions of data in accordance with one embodiment of the present invention. As illustrated, the original data desired to be parsed and split is plain text 3306 (i.e., the word "SUMMIT" is used as an example). It will be understood that any other type of data may be parsed and split in accordance with the present invention. A session key 3300 is generated. If the length of session key 3300 is not compatible with the length of original data 3306, then cipher feedback session key 3304 may be generated.

[0420] In one suitable approach, original data 3306 may be encrypted prior to parsing, splitting, or both. For example, as FIGURE 33 illustrates, original data 3306 may be XORed with any suitable value (e.g., with cipher feedback session key 3304, or with any other suitable value). It will be understood that any other suitable encryption technique may be used in place of or in addition to the XOR technique illustrate. It will further be understood that although FIGURE 33 is illustrated in terms of byte by byte operations, the operation may take place at the bit level or at any other suitable level. It will further be understood that, if desired, there need not be any encryption whatsoever of original data 3306.

[0421] The resultant encrypted data (or original data if no encryption took place) is then hashed to determine how to split the encrypted (or original) data among the output buckets (e.g., of which there are four in the illustrated example). In the illustrated example, the hashing takes place by bytes and is a function of cipher feedback session key 3304. It will be understood that this is merely illustrative. The hashing may be performed at the bit level, if desired. The hashing may be a function of any other suitable value besides cipher feedback session key 3304. In another suitable approach, hashing need not be used. Rather, any other suitable technique for splitting data may be employed.

[0422] FIGURE 34 is a block diagram of an illustrative process flow for restoring original data 3306 from two or more parsed and split portions of original data 3306 in accordance with one embodiment of the present invention. The process involves hashing the portions in reverse (i.e., to the process of FIGURE 33) as a function of cipher feedback session key 3304 to restore the encrypted original data (or original data if there was no encryption prior to the parsing and splitting). The encryption key may then be used to restore the original data (i.e.,

in the illustrated example, cipher feedback session key 3304 is used to decrypt the XOR encryption by XORing it with the encrypted data). This restores original data 3306.

[0423] FIGURE 35 shows how bit-splitting may be implemented in the example of FIGURES 33 and 34. A hash may be used (e.g., as a function of the cipher feedback session key, as a function of any other suitable value) to determine a bit value at which to split each byte of data. It will be understood that this is merely one illustrative way in which to implement splitting at the bit level. Any other suitable technique may be used.

[0424] It will be understood that any reference to hash functionality made herein may be made with respect to any suitable hash algorithm. These include for example, MD5 and SHA-1. Different hash algorithms may be used at different times and by different components of the present invention.

[0425] After a split point has been determined in accordance with the above illustrative procedure or through any other procedure or algorithm, a determination may be made with regard to which data portions to append each of the left and right segments. Any suitable algorithm may be used for making this determination. For example, in one suitable approach, a table of all possible distributions (e.g., in the form of pairings of destinations for the left segment and for the right segment) may be created, whereby a destination share value for each of the left and right segment may be determined by using any suitable hash function on corresponding data in the session key, cipher feedback session key, or any other suitable random or pseudo-random value, which may be generated and extended to the size of the original data. For example, a hash function of a corresponding byte in the random or pseudo-random value may be made. The output of the hash function is used to determine which pairing of destinations (i.e., one for the left segment and one for the right segment) to select from the table of all the destination combinations. Based on this result, each segment of the split data unit is appended to the respective two shares indicated by the table value selected as a result of the hash function.

[0426] Redundancy information may be appended to the data portions in accordance with the present invention to allow for the restoration of the original data using fewer than all the data portions. For example, if two out of four portions are desired to be sufficient for restoration of data, then additional data from the shares may be accordingly appended to each share in, for example, a round-robin manner (e.g., where the size of the original data is 4MB, then share 1 gets its own shares as well as those of shares 2 and 3; share 2 gets its own share as well as those of shares 3 and 4; share 3 gets its own share as well as those of shares 4

and 1; and share 4 gets its own shares as well as those of shares 1 and 2). Any such suitable redundancy may be used in accordance with the present invention.

[0427] It will be understood that any other suitable parsing and splitting approach may be used to generate portions of data from an original data set in accordance with the present invention. For example, parsing and splitting may be randomly or pseudo-randomly processed on a bit by bit basis. A random or pseudo-random value may be used (e.g., session key, cipher feedback session key, etc.) whereby for each bit in the original data, the result of a hash function on corresponding data in the random or pseudo-random value may indicate to which share to append the respective bit. In one suitable approach the random or pseudo-random value may be generated as, or extended to, 8 times the size of the original data so that the hash function may be performed on a corresponding byte of the random or pseudo-random value with respect to each bit of the original data. Any other suitable algorithm for parsing and splitting data on a bit by bit level may be used in accordance with the present invention. It will further be appreciated that redundancy data may be appended to the data shares such as, for example, in the manner described immediately above in accordance with the present invention.

[0428] In one suitable approach, parsing and splitting need not be random or pseudo-random. Rather, any suitable deterministic algorithm for parsing and splitting data may be used. For example, breaking up the original data into sequential shares may be employed as a parsing and splitting algorithm. Another example is to parse and split the original data bit by bit, appending each respective bit to the data shares sequentially in a round-robin manner. It will further be appreciated that redundancy data may be appended to the data shares such as, for example, in the manner described above in accordance with the present invention.

[0429] In one embodiment of the present invention, after the secure data parser generates a number of portions of original data, in order to restore the original data, certain one or more of the generated portions may be mandatory. For example, if one of the portions is used as an authentication share (e.g., saved on a physical token device), and if the fault tolerance feature of the secure data parser is being used (i.e., where fewer than all portions are necessary to restore the original data), then even though the secure data parser may have access to a sufficient number of portions of the original data in order to restore the original data, it may require the authentication share stored on the physical token device before it restores the original data. It will be understood that any number and types of particular shares may be required based on, for example, application, type of data, user, any other suitable factors, or any combination thereof.

[0430] In one suitable approach, the secure data parser or some external component to the secure data parser may encrypt one or more portions of the original data. The encrypted portions may be required to be provided and decrypted in order to restore the original data. The different encrypted portions may be encrypted with different encryption keys. For example, this feature may be used to implement a more secure "two man rule" whereby a first user would need to have a particular share encrypted using a first encryption and a second user would need to have a particular share encrypted using a second encryption key. In order to access the original data, both users would need to have their respective encryption keys and provide their respective portions of the original data. In one suitable approach, a public key may be used to encrypt one or more data portions that may be a mandatory share required to restore the original data. A private key may then be used to decrypt the share in order to be used to restore to the original data.

[0431] Any such suitable paradigm may be used that makes use of mandatory shares where fewer than all shares are needed to restore original data.

[0432] In one suitable embodiment of the present invention, distribution of data into a finite number of shares of data may be processed randomly or pseudo-randomly such that from a statistical perspective, the probability that any particular share of data receives a particular unit of data is equal to the probability that any one of the remaining shares will receive the unit of data. As a result, each share of data will have an approximately equal amount of data bits.

[0433] According to another embodiment of the present invention, each of the finite number of shares of data need not have an equal probability of receiving units of data from the parsing and splitting of the original data. Rather certain one or more shares may have a higher or lower probability than the remaining shares. As a result, certain shares may be larger or smaller in terms of bit size relative to other shares. For example, in a two-share scenario, one share may have a 1% probability of receiving a unit of data whereas the second share has a 99% probability. It should follow, therefore that once the data units have been distributed by the secure data parser among the two share, the first share should have approximately 1% of the data and the second share 99%. Any suitable probabilities may be used in accordance with the present invention.

[0434] It will be understood that the secure data parser may be programmed to distribute data to shares according to an exact (or near exact) percentage as well. For example, the secure data parser may be programmed to distribute 80% of data to a first share and the remaining 20% of data to a second share.

[0435] According to another embodiment of the present invention, the secure data parser may generate data shares, one or more of which have predefined sizes. For example, the secure data parser may split original data into data portions where one of the portions is exactly 256 bits. In one suitable approach, if it is not possible to generate a data portion having the requisite size, then the secure data parser may pad the portion to make it the correct size. Any suitable size may be used.

[0436] In one suitable approach, the size of a data portion may be the size of an encryption key, a splitting key, any other suitable key, or any other suitable data element.

[0437] As previously discussed, the secure data parser may use keys in the parsing and splitting of data. For purposes of clarity and brevity, these keys shall be referred to herein as "splitting keys." For example, the Session Master Key, previously introduced, is one type of splitting key. Also, as previously discussed, splitting keys may be secured within shares of data generated by the secure data parser. Any suitable algorithms for securing splitting keys may be used to secure them among the shares of data. For example, the Shamir algorithm may be used to secure the splitting keys whereby information that may be used to reconstruct a splitting key is generated and appended to the shares of data. Any other such suitable algorithm may be used in accordance with the present invention.

[0438] Similarly, any suitable encryption keys may be secured within one or more shares of data according to any suitable algorithm such as the Shamir algorithm. For example, encryption keys used to encrypt a data set prior to parsing and splitting, encryption keys used to encrypt a data portions after parsing and splitting, or both may be secured using, for example, the Shamir algorithm or any other suitable algorithm.

[0439] According to one embodiment of the present invention, an All or Nothing Transform (AoNT), such as a Full Package Transform, may be used to further secure data by transforming splitting keys, encryption keys, any other suitable data elements, or any combination thereof. For example, an encryption key used to encrypt a data set prior to parsing and splitting in accordance with the present invention may be transformed by an AoNT algorithm. The transformed encryption key may then be distributed among the data shares according to, for example, the Shamir algorithm or any other suitable algorithm. In order to reconstruct the encryption key, the encrypted data set must be restored (e.g., not necessarily using all the data shares if redundancy was used in accordance with the present invention) in order to access the necessary information regarding the transformation in accordance with AoNTs as is well known by one skilled in the art. When the original encryption key is retrieved, it may be used to decrypt the encrypted data set to retrieve the

original data set. It will be understood that the fault tolerance features of the present invention may be used in conjunction with the AoNT feature. Namely, redundancy data may be included in the data portions such that fewer than all data portions are necessary to restore the encrypted data set.

[0440] It will be understood that the AoNT may be applied to encryption keys used to encrypt the data portions following parsing and splitting either in place of or in addition to the encryption and AoNT of the respective encryption key corresponding to the data set prior to parsing and splitting. Likewise, AoNT may be applied to splitting keys.

[0441] In one embodiment of the present invention, encryption keys, splitting keys, or both as used in accordance with the present invention may be further encrypted using, for example, a workgroup key in order to provide an extra level of security to a secured data set.

[0442] In one embodiment of the present invention, an audit module may be provided that tracks whenever the secure data parser is invoked to split data.

[0443] FIGURE 36 illustrates possible options 3600 for using the components of the secure data parser in accordance with the invention. Each combination of options is outlined below and labeled with the appropriate step numbers from FIGURE 36. The secure data parser may be modular in nature, allowing for any known algorithm to be used within each of the function blocks shown in FIGURE 36. For example, other key splitting (e.g., secret sharing) algorithms such as Blakely may be used in place of Shamir, or the AES encryption could be replaced by other known encryption algorithms such as Triple DES. The labels shown in the example of FIGURE 36 merely depict one possible combination of algorithms for use in one embodiment of the invention. It should be understood that any suitable algorithm or combination of algorithms may be used in place of the labeled algorithms.

[0444] 1) 3610, 3612, 3614, 3615, 3616, 3617, 3618, 3619

[0445] Using previously encrypted data at step 3610, the data may be eventually split into a predefined number of shares. If the split algorithm requires a key, a split encryption key may be generated at step 3612 using a cryptographically secure pseudo-random number generator. The split encryption key may optionally be transformed using an All or Nothing Transform (AoNT) into a transform split key at step 3614 before being key split to the predefined number of shares with fault tolerance at step 3615. The data may then be split into the predefined number of shares at step 3616. A fault tolerant scheme may be used at step 3617 to allow for regeneration of the data from less than the total number of shares. Once the shares are created, authentication/integrity information may be embedded into the shares at step 3618. Each share may be optionally post-encrypted at step 3619.

[0446] 2) 3111, 3612, 3614, 3615, 3616, 3617, 3618, 3619

[0447] In some embodiments, the input data may be encrypted using an encryption key provided by a user or an external system. The external key is provided at step 3611. For example, the key may be provided from an external key store. If the split algorithm requires a key, the split encryption key may be generated using a cryptographically secure pseudo-random number generator at step 3612. The split key may optionally be transformed using an All or Nothing Transform (AoNT) into a transform split encryption key at step 3614 before being key split to the predefined number of shares with fault tolerance at step 3615. The data is then split to a predefined number of shares at step 3616. A fault tolerant scheme may be used at step 3617 to allow for regeneration of the data from less than the total number of shares. Once the shares are created, authentication/integrity information may be embedded into the shares at step 3618. Each share may be optionally post-encrypted at step 3619.

[0448] 3) 3612, 3613, 3614, 3615, 3612, 3614, 3615, 3616, 3617, 3618, 3619

[0449] In some embodiments, an encryption key may be generated using a cryptographically secure pseudo-random number generator at step 3612 to transform the data. Encryption of the data using the generated encryption key may occur at step 3613. The encryption key may optionally be transformed using an All or Nothing Transform (AoNT) into a transform encryption key at step 3614. The transform encryption key and/or generated encryption key may then be split into the predefined number of shares with fault tolerance at step 3615. If the split algorithm requires a key, generation of the split encryption key using a cryptographically secure pseudo-random number generator may occur at step 3612. The split key may optionally be transformed using an All or Nothing Transform (AoNT) into a transform split encryption key at step 3614 before being key split to the predefined number of shares with fault tolerance at step 3615. The data may then be split into a predefined number of shares at step 3616. A fault tolerant scheme may be used at step 3617 to allow for regeneration of the data from less than the total number of shares. Once the shares are created, authentication/integrity information will be embedded into the shares at step 3618. Each share may then be optionally post-encrypted at step 3619.

[0450] 4) 3612, 3614, 3615, 3616, 3617, 3618, 3619

[0451] In some embodiments, the data may be split into a predefined number of shares. If the split algorithm requires a key, generation of the split encryption key using a cryptographically secure pseudo-random number generator may occur at step 3612. The split key may optionally be transformed using an All or Nothing Transform (AoNT) into a transformed split key at step 3614 before being key split into the predefined number of shares

with fault tolerance at step 3615. The data may then be split at step 3616. A fault tolerant scheme may be used at step 3617 to allow for regeneration of the data from less than the total number of shares. Once the shares are created, authentication/integrity information may be embedded into the shares at step 3618. Each share may be optionally post-encrypted at step 3619.

[0452] Although the above four combinations of options are preferably used in some embodiments of the invention, any other suitable combinations of features, steps, or options may be used with the secure data parser in other embodiments.

[0453] The secure data parser may offer flexible data protection by facilitating physical separation. Data may be first encrypted, then split into shares with "m of n" fault tolerance. This allows for regeneration of the original information when less than the total number of shares is available. For example, some shares may be lost or corrupted in transmission. The lost or corrupted shares may be recreated from fault tolerance or integrity information appended to the shares, as discussed in more detail below.

[0454] In order to create the shares, a number of keys are optionally utilized by the secure data parser. These keys may include one or more of the following:

[0455] Pre-encryption key: When pre-encryption of the shares is selected, an external key may be passed to the secure data parser. This key may be generated and stored externally in a key store (or other location) and may be used to optionally encrypt data prior to data splitting.

[0456] Split encryption key: This key may be generated internally and used by the secure data parser to encrypt the data prior to splitting. This key may then be stored securely within the shares using a key split algorithm.

[0457] Split session key: This key is not used with an encryption algorithm; rather, it may be used to key the data partitioning algorithms when random splitting is selected. When a random split is used, a split session key may be generated internally and used by the secure data parser to partition the data into shares. This key may be stored securely within the shares using a key splitting algorithm.

[0458] Post encryption key: When post encryption of the shares is selected, an external key may be passed to the secure data parser and used to post encrypt the individual shares. This key may be generated and stored externally in a key store or other suitable location.

[0459] In some embodiments, when data is secured using the secure data parser in this way, the information may only be reassembled provided that all of the required shares and external encryption keys are present.

[0460] FIGURE 37 shows illustrative overview process 3700 for using the secure data

parser of the present invention in some embodiments. As described above, two well-suited functions for secure data parser 3706 may include encryption 3702 and backup 3704. As such, secure data parser 3706 may be integrated with a RAID or backup system or a hardware or software encryption engine in some embodiments.

[0461] The primary key processes associated with secure data parser 3706 may include one or more of pre-encryption process 3708, encrypt/transform process 3710, key secure process 3712, parse/distribute process 3714, fault tolerance process 3716, share authentication process 3716, and post-encryption process 3720. These processes may be executed in several suitable orders or combinations, as detailed in FIGURE 36. The combination and order of processes used may depend on the particular application or use, the level of security desired, whether optional pre-encryption, post-encryption, or both, are desired, the redundancy desired, the capabilities or performance of an underlying or integrated system, or any other suitable factor or combination of factors.

[0462] The output of illustrative process 3700 may be two or more shares 3722. As described above, data may be distributed to each of these shares randomly (or pseudo-randomly) in some embodiments. In other embodiments, a deterministic algorithm (or some suitable combination of random, pseudo-random, and deterministic algorithms) may be used.

[0463] In addition to the individual protection of information assets, there is sometimes a requirement to share information among different groups of users or communities of interest. It may then be necessary to either control access to the individual shares within that group of users or to share credentials among those users that would only allow members of the group to reassemble the shares. To this end, a workgroup key may be deployed to group members in some embodiments of the invention. The workgroup key should be protected and kept confidential, as compromise of the workgroup key may potentially allow those outside the group to access information. Some systems and methods for workgroup key deployment and protection are discussed below.

[0464] The workgroup key concept allows for enhanced protection of information assets by encrypting key information stored within the shares. Once this operation is performed, even if all required shares and external keys are discovered, an attacker has no hope of recreating the information without access to the workgroup key.

[0465] FIGURE 38 shows illustrative block diagram 3800 for storing key and data components within the shares. In the example of diagram 3800, the optional pre-encrypt and post-encrypt steps are omitted, although these steps may be included in other embodiments.

[0466] The simplified process to split the data includes encrypting the data using encryption key 3804 at encryption stage 3802. Portions of encryption key 3804 may then be split and stored within shares 3810 in accordance with the present invention. Portions of split encryption key 3806 may also be stored within shares 3810. Using the split encryption key, data 3808 is then split and stored in shares 3810.

[0467] In order to restore the data, split encryption key 3806 may be retrieved and restored in accordance with the present invention. The split operation may then be reversed to restore the ciphertext. Encryption key 3804 may also be retrieved and restored, and the ciphertext may then be decrypted using the encryption key.

[0468] When a workgroup key is utilized, the above process may be changed slightly to protect the encryption key with the workgroup key. The encryption key may then be encrypted with the workgroup key prior to being stored within the shares. The modified steps are shown in illustrative block diagram 3900 of FIGURE 39.

[0469] The simplified process to split the data using a workgroup key includes first encrypting the data using the encryption key at stage 3902. The encryption key may then be encrypted with the workgroup key at stage 3904. The encryption key encrypted with the workgroup key may then be split into portions and stored with shares 3912. Split key 3908 may also be split and stored in shares 3912. Finally, portions of data 3910 are split and stored in shares 3912 using split key 3908.

[0470] In order to restore the data, the split key may be retrieved and restored in accordance with the present invention. The split operation may then be reversed to restore the ciphertext in accordance with the present invention. The encryption key (which was encrypted with the workgroup key) may be retrieved and restored. The encryption key may then be decrypted using the workgroup key. Finally, the ciphertext may be decrypted using the encryption key.

[0471] There are several secure methods for deploying and protecting workgroup keys. The selection of which method to use for a particular application depends on a number of factors. These factors may include security level required, cost, convenience, and the number of users in the workgroup. Some commonly used techniques used in some embodiments are provided below:

[0472] Hardware-based Key Storage

Hardware-based solutions generally provide the strongest guarantees for the security of encryption/decryption keys in an encryption system. Examples of hardware-based storage solutions include tamper-resistant key token devices which store keys in a portable device (e.g., smartcard/dongle), or non-portable key storage peripherals. These devices are designed

to prevent easy duplication of key material by unauthorized parties. Keys may be generated by a trusted authority and distributed to users, or generated within the hardware.

Additionally, many key storage systems provide for multi-factor authentication, where use of the keys requires access both a physical object (token) and a passphrase or biometric.

[0473] Software-based Key Storage

While dedicated hardware-based storage may be desirable for high-security deployments or applications, other deployments may elect to store keys directly on local hardware (e.g., disks, RAM or non-volatile RAM stores such as USB drives). This provides a lower level of protection against insider attacks, or in instances where an attacker is able to directly access the encryption machine.

[0474] To secure keys on disk, software-based key management often protects keys by storing them in encrypted form under a key derived from a combination of other authentication metrics, including: passwords and passphrases, presence of other keys (e.g., from a hardware-based solution), biometrics, or any suitable combination of the foregoing. The level of security provided by such techniques may range from the relatively weak key protection mechanisms provided by some operating systems (e.g., MS Windows and Linux), to more robust solutions implemented using multi-factor authentication.

[0475] The secure data parser of the present invention may be advantageously used in a number of applications and technologies. For example, email system, RAID systems, video broadcasting systems, database systems, tape backup systems, or any other suitable system may have the secure data parser integrated at any suitable level. As previously discussed, it will be understood that the secure data parser may also be integrated for protection and fault tolerance of any type of data in motion through any transport medium, including, for example, wired, wireless, or physical transport mediums. As one example, voice over Internet protocol (VoIP) applications may make use of the secure data parser of the present invention to solve problems relating to echoes and delays that are commonly found in VoIP. The need for network retry on dropped packets may be eliminated by using fault tolerance, which guarantees packet delivery even with the loss of a predetermined number of shares. Packets of data (e.g., network packets) may also be efficiently split and restored "on-the-fly" with minimal delay and buffering, resulting in a comprehensive solution for various types of data in motion. The secure data parser may act on network data packets, network voice packets, file system data blocks, or any other suitable unit of information. In addition to being integrated with a VoIP application, the secure data parser may be integrated with a file-sharing application (e.g., a peer-to-peer file-sharing application), a video broadcasting

application, an electronic voting or polling application (which may implement an electronic voting protocol and blind signatures, such as the Sensus protocol), an email application, or any other network application that may require or desire secure communication.

[0476] In some embodiments, support for network data in motion may be provided by the secure data parser of the present invention in two distinct phases -- a header generation phase and a data partitioning phase. Simplified header generation process 4000 and simplified data partitioning process 4010 are shown in FIGURES 40A and 40B, respectively. One or both of these processes may be performed on network packets, file system blocks, or any other suitable information.

[0477] In some embodiments, header generation process 4000 may be performed one time at the initiation of a network packet stream. At step 4002, a random (or pseudo-random) split encryption key, K, may be generated. The split encryption key, K, may then be optionally encrypted (e.g., using the workgroup key described above) at AES key wrap step 4004. Although an AES key wrap may be used in some embodiments, any suitable key encryption or key wrap algorithm may be used in other embodiments. AES key wrap step 4004 may operate on the entire split encryption key, K, or the split encryption key may be parsed into several blocks (e.g., 64-bit blocks). AES key wrap step 4004 may then operate on blocks of the split encryption key, if desired.

[0478] At step 4006, a secret sharing algorithm (e.g., Shamir) may be used to split the split encryption key, K, into key shares. Each key share may then be embedded into one of the output shares (e.g., in the share headers). Finally, a share integrity block and (optionally) a post-authentication tag (e.g., MAC) may be appended to the header block of each share. Each header block may be designed to fit within a single data packet.

[0479] After header generation is complete (e.g., using simplified header generation process 4000), the secure data parser may enter the data partitioning phase using simplified data splitting process 4010. Each incoming data packet or data block in the stream is encrypted using the split encryption key, K, at step 4012. At step 4014, share integrity information (e.g., a hash H) may be computed on the resulting ciphertext from step 4012. For example, a SHA-256 hash may be computed. At step 4106, the data packet or data block may then be partitioned into two or more data shares using one of the data splitting algorithms described above in accordance with the present invention. In some embodiments, the data packet or data block may be split so that each data share contains a substantially random distribution of the encrypted data packet or data block. The integrity information (e.g., hash

H) may then be appended to each data share. An optional post-authentication tag (e.g., MAC) may also be computed and appended to each data share in some embodiments.

[0480] Each data share may include metadata, which may be necessary to permit correct reconstruction of the data blocks or data packets. This information may be included in the share header. The metadata may include such information as cryptographic key shares, key identities, share nonces, signatures/MAC values, and integrity blocks. In order to maximize bandwidth efficiency, the metadata may be stored in a compact binary format.

[0481] For example, in some embodiments, the share header includes a cleartext header chunk, which is not encrypted and may include such elements as the Shamir key share, per-session nonce, per-share nonce, key identifiers (e.g., a workgroup key identifier and a post-authentication key identifier). The share header may also include an encrypted header chunk, which is encrypted with the split encryption key. An integrity header chunk, which may include integrity checks for any number of the previous blocks (e.g., the previous two blocks) may also be included in the header. Any other suitable values or information may also be included in the share header.

[0482] As shown in illustrative share format 4100 of FIGURE 41, header block 4102 may be associated with two or more output blocks 4104. Each header block, such as header block 4102, may be designed to fit within a single network data packet. In some embodiments, after header block 4102 is transmitted from a first location to a second location, the output blocks may then be transmitted. Alternatively, header block 4102 and output blocks 4104 may be transmitted at the same time in parallel. The transmission may occur over one or more similar or dissimilar communications paths.

[0483] Each output block may include data portion 4106 and integrity/authenticity portion 4108. As described above, each data share may be secured using a share integrity portion including share integrity information (e.g., a SHA-256 hash) of the encrypted, pre-partitioned data. To verify the integrity of the outputs blocks at recovery time, the secure data parser may compare the share integrity blocks of each share and then invert the split algorithm. The hash of the recovered data may then be verified against the share hash.

[0484] As previously mentioned, in some embodiments of the present invention, the secure data parser may be used in conjunction with a tape backup system. For example, an individual tape may be used as a node (i.e., portion/share) in accordance with the present invention. Any other suitable arrangement may be used. For example, a tape library or subsystem, which is made up of two or more tapes, may be treated as a single node.

[0485] Redundancy may also be used with the tapes in accordance with the present invention. For example, if a data set is apportioned among four tapes (i.e., portions/shares), then two of the four tapes may be necessary in order to restore the original data. It will be understood that any suitable number of nodes (i.e., less than the total number of nodes) may be required to restore the original data in accordance with the redundancy features of the present invention. This substantially increases the probability for restoration when one or more tapes expire.

[0486] Each tape may also be digitally protected with a SHA-256, HMAC hash value, any other suitable value, or any combination thereof to insure against tampering. Should any data on the tape or the hash value change, that tape would not be a candidate for restoration and any minimum required number of tapes of the remaining tapes would be used to restore the data.

[0487] In conventional tape backup systems, when a user calls for data to be written to or read from a tape, the tape management system (TMS) presents a number that corresponds to a physical tape mount. This tape mount points to a physical drive where the data will be mounted. The tape is loaded either by a human tape operator or by a tape robot in a tape silo.

[0488] Under the present invention, the physical tape mount may be considered a logical mount point that points to a number of physical tapes. This not only increases the data capacity but also improves the performance because of the parallelism.

[0489] For increased performance the tape nodes may be or may include a RAID array of disks used for storing tape images. This allows for high-speed restoration because the data may always be available in the protected RAID.

[0490] In any of the foregoing embodiments, the data to be secured may be distributed into a plurality of shares using deterministic, probabilistic, or both deterministic and probabilistic data distribution techniques. In order to prevent an attacker from beginning a crypto attack on any cipher block, the bits from cipher blocks may be deterministically distributed to the shares. For example, the distribution may be performed using the BitSegment routine, or the BlockSegment routine may be modified to allow for distribution of portions of blocks to multiple shares. This strategy may defend against an attacker who has accumulated less than "M" shares.

[0491] In some embodiments, a keyed secret sharing routine may be employed using keyed information dispersal (e.g., through the use of a keyed information dispersal algorithm or "IDA"). The key for the keyed IDA may also be protected by one or more external workgroup keys, one or more shared keys, or any combination of workgroup keys and shared

keys. In this way, a multi-factor secret sharing scheme may be employed. To reconstruct the data, at least "M" shares plus the workgroup key(s) (and/or shared key(s)) may be required in some embodiments. The IDA (or the key for the IDA) may also be driven into the encryption process. For example, the transform may be driven into the clear text (e.g., during the pre-processing layer before encrypting) and may further protect the clear text before it is encrypted.

[0492] For example, in some embodiments, keyed information dispersal is used to distribute unique portions of data from a data set into two or more shares. The keyed information dispersal may use a session key to first encrypt the data set, to distribute unique portions of encrypted data from the data set into two or more encrypted data set shares, or both encrypt the data set and distribute unique portions of encrypted data from the data set into the two or more encrypted data set shares. For example, to distribute unique portions of the data set or encrypted data set, secret sharing (or the methods described above, such as BitSegment or BlockSegment) may be used. The session key may then optionally be transformed (for example, using a full package transform or AoNT) and shared using, for example, secret sharing (or the keyed information dispersal and session key).

[0493] In some embodiments, the session key may be encrypted using a shared key (e.g., a workgroup key) before unique portions of the key are distributed or shared into two or more session key shares. Two or more user shares may then be formed by combining at least one encrypted data set share and at least one session key share. In forming a user share, in some embodiments, the at least one session key share may be interleaved into an encrypted data set share. In other embodiments, the at least one session key share may be inserted into an encrypted data set share at a location based at least in part on the shared workgroup key. For example, keyed information dispersal may be used to distribute each session key share into a unique encrypted data set share to form a user share. Interleaving or inserting a session key share into an encrypted data set share at a location based at least in part on the shared workgroup may provide increased security in the face of cryptographic attacks. In other embodiments, one or more session key shares may be appended to the beginning or end of an encrypted data set share to form a user share. The collection of user shares may then be stored separately on at least one data depository. The data depository or depositories may be located in the same physical location (for example, on the same magnetic or tape storage device) or geographically separated (for example, on physically separated servers in different geographic locations). To reconstruct the original data set, an authorized set of user shares and the shared workgroup key may be required.

[0494] Keyed information dispersal may be secure even in the face of key-retrieval oracles. For example, take a blockcipher E and a key-retrieval oracle for E that takes a list $(X_1, Y_1), \dots, (X_c, Y_c)$ of input/output pairs to the blockcipher, and returns a key K that is consistent with the input/output examples (e.g., $Y_i = E_K(X_i)$ for all i). The oracle may return the distinguished value \perp if there is no consistent key. This oracle may model a cryptanalytic attack that may recover a key from a list of input/output examples.

[0495] Standard blockcipher-based schemes may fail in the presence of a key-retrieval oracle. For example, CBC encryption or the CBC MAC may become completely insecure in the presence of a key-retrieval oracle.

[0496] If Π^{IDA} is an IDA scheme and Π^{Enc} is an encryption scheme given by a mode of operation of some blockcipher E , then $(\Pi^{\text{IDA}}, \Pi^{\text{Enc}})$ provides security in the face of a key-retrieval attack if the two schemes, when combined with an arbitrary perfect secret-sharing scheme (PSS) as per HK1 or HK2, achieve the robust computational secret sharing (RCSS) goal, but in the model in which the adversary has a key-retrieval oracle.

[0497] If there exists an IDA scheme Π^{IDA} and an encryption scheme Π^{Enc} such that the pair of schemes provides security in the face of key-retrieval attacks, then one way to achieve this pair may be to have a “clever” IDA and a “dumb” encryption scheme. Another way to achieve this pair of schemes may be to have a “dumb” IDA and a “clever” encryption scheme.

[0498] To illustrate the use of a clever IDA and a dumb encryption scheme, in some embodiments, the encryption scheme may be CBC and the IDA may have a “weak privacy” property. The weak privacy property means, for example, that if the input to the IDA is a random sequence of blocks $M = M_1 \dots M_l$ and the adversary obtains shares from a non-authorized collection, then there is some block index i such that it is infeasible for the adversary to compute M_i . Such a weakly-private IDA may be built by first applying to M an information-theoretic AoNT, such as Stinson’s AoNT, and then applying a simple IDA such as BlockSegment, or a bit-efficient IDA like Rabin’s scheme (e.g., Reed-Solomon encoding).

[0499] To illustrate the use of a dumb IDA and a clever encryption scheme, in some embodiments, one may use a CBC mode with double encryption instead of single encryption. Now any IDA may be used, even replication. Having the key-retrieval oracle for the blockcipher would be useless to an adversary, as the adversary will be denied any singly-enciphered input/output example.

[0500] While a clever IDA has value, it may also be inessential in some contexts, in the sense that the “smarts” needed to provide security in the face of a key-retrieval attack could have been “pushed” elsewhere. For example, in some embodiments, no matter how smart the

IDA, and for whatever goal is trying to be achieved with the IDA in the context of HK1/HK2, the smarts may be pushed out of the IDA and into the encryption scheme, being left with a fixed and dumb IDA.

[0501] Based on the above, in some embodiments, a “universally sound” clever IDA Π^{IDA} may be used. For example, an IDA is provided such that, for all encryption schemes Π^{Enc} , the pair $(\Pi^{\text{IDA}}, \Pi^{\text{Enc}})$ universally provides security in the face of key-retrieval attacks.

[0502] In some embodiments, an encryption scheme is provided that is RCSS secure in the face of a key-retrieval oracle. The scheme may be integrated with HK1/HK2, with any IDA, to achieve security in the face of key-retrieval. Using the new scheme may be particularly useful, for example, for making symmetric encryption schemes more secure against key-retrieval attacks.

[0503] As mentioned above, classical secret-sharing notions are typically unkeyed. Thus, a secret is broken into shares, or reconstructed from them, in a way that requires neither the dealer nor the party reconstructing the secret to hold any kind of symmetric or asymmetric key. The secure data parser described herein, however, is optionally keyed. The dealer may provide a symmetric key that, if used for data sharing, may be required for data recovery. The secure data parser may use the symmetric key to disperse or distribute unique portions of the message to be secured into two or more shares.

[0504] The shared key may enable multi-factor or two-factor secret-sharing (2FSS). The adversary may then be required to navigate through two fundamentally different types of security in order to break the security mechanism. For example, to violate the secret-sharing goals, the adversary (1) may need to obtain the shares of an authorized set of players, and (2) may need to obtain a secret key that it should not be able to obtain (or break the cryptographic mechanism that is keyed by that key).

[0505] In some embodiments, a new set of additional requirements is added to the RCSS goal. The additional requirements may include the “second factor”—key possession. These additional requirements may be added without diminishing the original set of requirements. One set of requirements may relate to the adversary’s inability to break the scheme if it knows the secret key but does not obtain enough shares (e.g., the classical or first-factor requirements) while the other set of requirements may relate to the adversary’s inability to break the scheme if it does have the secret key but manages to get hold of all of the shares (e.g., the new or second-factor requirements).

[0506] In some embodiments, there may be two second-factor requirements: a privacy requirement and an authenticity requirement. In the privacy requirement, a game may be

involved where a secret key K and a bit b are selected by the environment. The adversary now supplies a pair of equal-length messages in the domain of the secret-sharing scheme, M_1^0 and M_1^1 . The environment computes the shares of M_1^b to get a vector of shares, $S_1 = (S_1[1], \dots, S_1[n])$, and it gives the shares S_1 (all of them) to the adversary. The adversary may now choose another pair of messages (M_2^0, M_2^1) and everything proceeds as before, using the same key K and hidden bit b . The adversary's job is to output the bit b' that it believes to be b . The adversary privacy advantage is one less than twice the probability that $b = b'$. This game captures the notion that, even learning all the shares, the adversary still cannot learn anything about the shared secret if it lacks the secret key.

[0507] In the authenticity requirement, a game may be involved where the environment chooses a secret key K and uses this in the subsequent calls to Share and Recover. Share and Recover may have their syntax modified, in some embodiments, to reflect the presence of this key. Then the adversary makes Share requests for whatever messages M_1, \dots, M_q it chooses in the domain of the secret-sharing scheme. In response to each Share request it gets the corresponding n -vector of shares, S_1, \dots, S_q . The adversary's aim is to forge a new plaintext; it wins if it outputs a vector of shares S' such that, when fed to the Recover algorithm, results in something not in $\{M_1, \dots, M_q\}$. This is an "integrity of plaintext" notion.

[0508] There are two approaches to achieve multi-factor secret-sharing. The first is a generic approach -- generic in the sense of using an underlying (R)CSS scheme in a black-box way. An authenticated-encryption scheme is used to encrypt the message that is to be CSS-shared, and then the resulting ciphertext may be shared out, for example, using a secret sharing algorithm, such as Blakely or Shamir.

[0509] A potentially more efficient approach is to allow the shared key to be the workgroup key. Namely, (1) the randomly generated session key of the (R)CSS scheme may be encrypted using the shared key, and (2) the encryption scheme applied to the message (e.g., the file) may be replaced by an authenticated-encryption scheme. This approach may entail only a minimal degradation in performance.

[0510] Although some applications of the secure data parser are described above, it should be clearly understood that the present invention may be integrated with any network application in order to increase security, fault-tolerance, anonymity, or any suitable combination of the foregoing.

[0511] The parsing and/or splitting processes described above may, in some implementations, be employed in secure file sharing applications. In some implementations,

the secure filing sharing is performed by the illustrative secure sharing system 4200 depicted in the block diagrams of FIGURE 42.

[0512] FIGURE 42A depicts two user computing devices, User 1 device 4202a and User 2 device 4202b. One or more data sets may be stored in memory on User 1 device 4202a, such as file ANYFILE1 4204a and files stored in the directory SHARED\ 4206a. Similarly, one or more data sets may be stored in memory on User 2 device. User 1 device 4202a and User 2 device 4202b are each in communication (via one or more wireless or wired communications networks, not shown) with multiple storage depositories 4208a, 4208b and 4208c. The storage depositories 4208a, 4208b and 4208c are illustrated as being located in computing cloud storage, but may be any suitable network-attached storage devices, such as those provided by at least one network storage provider. It will be understood in FIGURE 42 that any suitable number and any suitable types of network storage providers may be used. In some implementations, such as the implementation illustrated in FIGURE 42, a secure sharing system includes at least three storage depositories (e.g., three cloud storage providers). In some implementations, the number of storage depositories included in a secure sharing system is equal to the number of shares into which data is split (e.g., four storage depositories in a 3 of 4 cryptographic split), as described in detail herein. The storage depositories may be managed by storage provider servers, each of which may be configured to supply storage on-demand, authenticate access to the storage, and provide upload, download, delete, and list functionality.

[0513] User 1 device 4202a and User 2 device 4202b are also each in communication (via one or more wireless or wired communications networks, not shown) with registration server 4210. Registration server 4210 may be configured to register users of secure sharing system 4200 (including individual users, user devices, and groups of users or devices), store user credentials such as e-mail address or username, authenticate users (e.g., based on the stored credentials), look up a user by their e-mail address or other credentials, transmit a public key to a cryptographic sharing client (as described in detail below), de-authorize one or more users from accessing registration server 4210, accept payment for use of one or more aspects of secure sharing system 4200, and enforce the expiration of a user's access to registration server 4200.

[0514] User 1 device 4202a and User 2 device 4202b each include processors configured to execute a cryptographic sharing client. In some implementations, the cryptographic sharing client provides cryptographic splitting operations as described above with respect to the secure parser and other systems disclosed herein. In some implementations, during initial

configuration of a user device with the cryptographic sharing client (e.g., during installation of a cryptographic sharing client software package), the cryptographic sharing client creates a shared directory in the user device (e.g., the directory SHARED\ 4206a during installation of the cryptographic sharing client in User 1 device 4202a, or the directory SHARED\ 4206b during installation of the cryptographic sharing client in User 2 device 4202b). During initial configuration, the cryptographic sharing client may capture information identifying a user associated with the user device (such as a username and e-mail address) and may generate an asymmetric key pair (including a private key and a public key) associated with that user. The cryptographic sharing client stores the private key locally to the user device (e.g., in a memory device included with the user device or in a memory device locally connected or securely available to the user device), and transmits the public key for storage at registration server 4210. In some implementations, registration server 4210 may also store any suitable group information that may define a group of user or user devices (e.g., by usernames or other identifying information or by user device identification information). Group affiliations may be provided to registration server 4210 when the user device communications with registration server 4210. For example, a group to which a user device belongs may be indicated by a sender of a secure e-mail when attempting to transmit data to other members of the group. In some implementations, the user devices that access registration server 4210 may be designated using access groups such as "sharing" workgroups.

[0515] The operation of secure sharing system 4200 will now be illustrated by an example in which User 1, the user associated with User 1 device 4202a, wishes to securely share the file ANYFILE1 4204a with User 2, the user associated with User 2 device 4202b. User 1 is associated with a private-public key pair Pri-U1 4214a and Pub-U1 4212a, and User 2 is associated with a private-public key pair Pri-U2 4214b and Pub-U2 4212b. The public keys associated with Users 1 and 2, Pub-U1 4212a and Pub-U2 4212b, are stored in registration server 4210, while the private keys Pri-U1 4214a and Pri-U2 4214b are locally available to User 1 device 4202a and User 2 device 4202b, respectively. In some implementations, every user or user device may be associated with a respective private-public key pair. In some implementations, a workgroup or collection of users or user devices may share a private key and corresponding public key. The public keys for users of the secure sharing system 4200 are stored on the registration server 4210 and may be retrieved by a user's respective cryptographic sharing client.

[0516] FIGURE 42A illustrates User 1 initiating a secure sharing process by moving file ANYFILE1 4204a into the directory SHARED\ 4206a. This technique for initiating a secure

sharing process is not unique, and many other techniques may be used. In some implementations, User 1 may access the cryptographic sharing client by selecting an icon in the system tray of an operating system. In some implementations, User 1 may select ANYFILE1 4204a on a display by right-clicking on an image of the file with a mouse, and may then select "Cryptographic Sharing" as an option from a pull-down menu displayed by the cryptographic sharing client in response to the right-click. User 1 may then identify the individual or group with which ANYFILE1 4204a is to be shared, e.g., by selecting an individual or group e-mail address from a list of e-mail addresses. This list may be populated in a manner common to all users of the secure sharing system 4200 (e.g., using an e-mail lookup of all users), or may be populated using information about User 1's past sharing or other communication activities. For example, the list of e-mail addresses may be populated by identifying the users to which User 1 has previously securely shared files or sent e-mails. Other identifying, such as usernames or real names, may be used instead of or in addition to e-mail addresses.

[0517] FIGURE 42B illustrates the cryptographic sharing client of User 1 device 4202a accessing registration server 4210 to retrieve the public key Pub-U2 4212b associated with User 2. In some implementations, User 1 device 4202a must authenticate itself to registration server 4210 before access to the public key Pub-U2 4212b is allowed. The cryptographic sharing client of User 1 device 4202a may do so by supplying identifying information, such as User 1's e-mail address. User 1 device 4202a also accesses the public key Pub-U1 4212a associated with User 1, which may be stored locally to User 1 device 4202a or retrieved from registration server 4210. To begin securing the file ANYFILE1 4204a for transfer, the cryptographic sharing client of User 1 device 4202a encrypts the file ANYFILE1 4204a using a file session key. In some implementations, the file session key is a workgroup key or an internal key. Once the public keys Pub-U1 4212a and Pub-U2 4212b are available, the cryptographic sharing client of User 1 device 4202a encrypts the file session key using User 1's public key Pub-U1 4212a to form a first encrypted key, and encrypts the file session key using User 2's public key Pub-U2 4212b to form a second encrypted key. In some implementations, before the file session key is encrypted with User 2's public key Pub-U2 4212b, the file session key is encrypted with a workgroup key to which User 2 has access. In some implementations, the file session key is encrypted with an additional internal key encryption key (KEK) generated by the cryptographic sharing client of User 1 device 4202a. It will be understood that the file session key may be encrypted in one or more rounds of encryption, using the same or different encryption techniques and the same or different

encryption keys. The cryptographic sharing client of User 1 device 4202a may also sign the encrypted key using the private key Pri-U1 4214a associated with User 1 in order to authenticate the encrypted key. In some implementations, the first and second encrypted keys are packaged with the encrypted data, as part of the encrypted data at-rest, or are packaged with the encrypted data in-motion as data packet headers or in a dedicated header packet of the encrypted data that is transmitted to storage depositories 4208a, 4208b and 4208c, as described below.

[0518] Next, the cryptographic sharing client of User 1 device 4202a cryptographically splits the file ANYFILE1 4204a into two or more shares using the private key Pri-U1 4214a associated with User 1 and the public key Pub-U2 4212b associated with User 2 such that only users with access to the private key Pri-U1 4214a associated with User 1 or access to the private key Pri-U2 4214b associated with User 2 can restore the file ANYFILE1 4204a. The cryptographic splitting may involve any suitable cryptographic splitting process such as the cryptographic splitting process described above in which data is split into a certain redundant number of cryptographic shares, e.g., 2 of 3 shares. More generally, the file may be split into M of N shares, where M is at least one less than N and M shares are required to reconstitute or reassemble the file so as to provide sufficient redundancy in the shares such that only a subset of the shares are needed to reassemble or restore the data to its original or useable form. In some implementations, a secure parser generates the shares of data and/or encrypts the shares and uses a protocol that includes wrapping the session key with a workgroup key, as described above. In such implementations, secure sharing system 4200 may create a one-time symmetric key which is used to wrap the session key (as the workgroup key described above typically would). The wrapped session key is then further encrypted with the public keys Pub-U1 4212a associated with User 1 and Pub-U2 4212b associated with User 2 to form first and second encrypted keys, as described above. The one-time symmetric key may be discarded after the cryptographic sharing client of User 2 device 4202b decrypts the session key, for example, as described below. In some implementations, the workgroup key or one-time key may be an asymmetric key (e.g., a public key of a private-public key pair). It will be understood that splitting operations and encryption operations may be performed in any order. For example, a data set may be split into shares, then the shares encrypted, or a data set may be encrypted then split into shares. Multiple splitting and multiple encryption operations may also be performed, in any order. Additionally, any additional keys used to encrypt the file session key (e.g., a KEK) may themselves be split and encrypted any number of times in any suitable order. These shares of encrypted additional keys may be stored and transmitted in

any of the ways described below for encrypted data and encrypted keys. The secure sharing techniques disclosed herein may be advantageously used with other cryptographic or security systems already in place by securing the encryption keys used in these in-place systems with additional layers of security without interfering with or compromising the in-place systems. In particular, data security systems that include internal session or workgroup keys may continue to use these keys to secure data, with the secure sharing system of FIGURE 42 operating on top of such systems to enable secure data sharing.

[0519] FIGURE 42C illustrates the cryptographic sharing client of User 1 device 4202 distributing the shares to storage depositories 4208a, 4208b and 4208c. Each of the multiple storage depositories 4208a, 4208b and 4208c may only receive a number of shares that is less than the number of shares needed to restore the file ANYFILE1 4204a. In some implementations, only one share is sent to each one of storage depositories 4208a, 4208b and 4208c. In some implementations, the shares are temporarily stored in the storage depositories 4208a, 4208b and 4208c (e.g., when the file ANYFILE1 4204a is securely attached to an e-mail that will be later transmitted to User 2 device 4202b). Temporary storage may end, for example, after a predetermined period of time has elapsed, or when a particular event occurs (e.g., when the file ANYFILE1 4204a is retrieved by User 2 device 4202b from the storage depositories 4208a, 4208b and 4208c). In such implementations, the storage depositories 4208a, 4208b and 4208c may include one or more temporary cloud storage servers, for example. In some implementations, the shares are persistently stored in the storage depositories 4208a, 4208b and 4208c (e.g., when the file ANYFILE1 4204a is part of a shared directory that may be accessed by one or more authorized users). In such implementations, the storage depositories 4208a, 4208b and 4208c may include one or more persistent or permanent cloud storage servers. Data stored on a persistent basis may be subject to deletion after a suitable time period (e.g., one year). The expiration period for temporary or persistent storage may be set by one or more of storage depositories 4208a, 4208b and 4208c, or by registration server 4210. The shares of data stored in the storage depositories 4208a, 4208b and 4208c may be stored as files, objects, or in any other suitable form, and the form may differ between depositories. In implementations in which the encrypted file session key was also signed using the private key Pri-U1 4214a associated with User 1, a user attempting to access the stored data may also have to validate the encrypted file session key using the public key Pub-U1 4212a associated with User 1 (as retrieved from registration server 4210). User 2 can restore the file after authentication that the file was transmitted by User 1.

[0520] FIGURE 42D illustrates the cryptographic sharing client of User 2 device 4202b retrieving some or all of the shares from storage depositories 4208a, 4208b and 4208c. Although FIGURE 42D shows User 2 device 4202b accessing all three of the storage depositories, User 2 device 4202b may only access some of the storage depositories on which shares are stored, as long as a sufficient number of shares may be retrieved to restore the file ANYFILE1 4204a. In some implementations, the cryptographic sharing client of User 2 device 4202b periodically scans and downloads data from storage depositories 4208a, 4208b and 4208c to storage local to User 2 device 4202b. This periodic scanning and downloading may be performed by a batch processing software application running on the cryptographic sharing client (e.g., as a background task), but data being shared with User 2 device 4202b may be retrieved using any suitable technique. For example, the registration server 4210 may cause the data to be pushed to User 2 device 4202b (e.g., by recognizing identifying information of User 2 or User 2 device 4202b transmitted or stored with one or more of the shares). In some implementations, User 2 device 4202b periodically polls registration server 4210 or storage depositories 4208a, 4208b and 4208c to determine if any data has been provided that is to be shared with User 2 device 4202b. In some implementations, registration server 4210 provides a notification to User 2 or User 2 device 4202b (such as an e-mail alert) that a file has been placed in the directory SHARED\4206a of User 1 device 4202a, or that data intended for User 2 is available on one or more of storage depositories 4208a, 4208b and 4208c. User 2 device 4202b may, in response to this notification, pull sufficient shares for restoration of ANYFILE1 4204a from storage depositories 4208a, 4208b and 4208c.

[0521] Once one or more shares has been retrieved from storage depositories 4208a, 4208b and 4208c, the cryptographic sharing client of User 2 device 4202b then validates the encrypted file session key using the public key Pub-U1 4212a associated with User 1 (if the encrypted file session key was signed by the cryptographic sharing client of User 1 device 4202a), then decrypts the second encrypted key to restore the file session key using the private key Pri-U2 4214b associated with User 2. If a sufficient number of shares have been received for restoration, the cryptographic sharing client of User 2 device 4202b then restores the shared file ANYFILE1 4204b at User 2 device 4202b. In this manner, the file ANYFILE1 4204a is securely shared with User 2. The restored file ANYFILE 1 4204b may be stored locally to User 2 device 4202b; for example, in the directory SHARED\4206b as shown in FIGURE 42E. Any suitable messaging or notifications may be provided to User 1, User 2, or both, to indicate the status or progression of the secure sharing process. For example, a notification may be provided by registration server 4210 to User 1, User 1, or

both, when a the public key Pub-U2 4212b associated with User 2 is accessed at registration server 4210 by the cryptographic sharing client of User 1 device 4202a, indicating that sharing has begun, or when a the public key Pub-U1 4212a associated with User 1 is accessed at registration server 4210 by the cryptographic sharing client of User 2 device 4202b, indicating that validation has begun.

[0522] The foregoing discussion of FIGURE 42 has focused on the retrieval of securely shared data from storage depositories 42084a, 4208b and 4208c by User 2 device 4202b, but the data may also be retrieved by User 1 device 4202a by decrypting the first encrypted key (e.g., the file session key encrypted with the public key Pub-U1 4212a) to restore the file session key, then decrypting the encrypted data set using the file session key. Thus, User 1 device 4202a may have access to the securely shared file along with any other desired users. Additionally, although the cryptographic sharing client is discussed as executed at the user devices in FIGURE 42, in some implementations, the cryptographic sharing client is executed at one or more central servers, such as a corporate server. In some such implementations, the central server(s) may hold private keys for the users, perform the cryptographic splitting operations described herein, and may store the securely shared data.

[0523] It will be understood that the securing sharing systems and techniques described above with reference to FIGURE 42 can enable secure sharing between any combination of an individual user, multiple individual users, a group of individual users (e.g., a workgroup), and multiple groups of individual users. For example, a user may use secure sharing system 4200 to securely store files for his or her own use by treating the user as both User 1 and User 2 in the techniques described above with reference to FIGURE 42. In some implementations, if User 1 wishes to share ANYFILE1 4204a with User 2 and a third user, User 3, the cryptographic sharing client of User 1 device 4202a may perform the operations described above for sharing ANYFILE1 4204a with User 2, and may also perform the analogous operations described above for sharing ANYFILE1 4204a with User 3.

[0524] FIGURE 43 illustrates an implementation in which a cryptographic sharing client of a user device is configured to perform a combined sharing operation to securely share a data set with a plurality of users (User 1 through User M in FIGURE 43). This plurality of users may include the user device that is configured to perform the sharing operations. In FIGURE 43, for each user, the cryptographic sharing client of the user device retrieves a public key associated with that user (e.g., from registration server 4210 of FIGURE 42) and encrypts the file session key (the key used to encrypt the data set as described above with reference to the encryption of the file ANYFILE1 4204a in FIGURE 42B) with that public

key. For example, as shown in FIGURE 43, the cryptographic sharing client encrypts the session key with the public key associated with User 1 (operation 4306) to form encrypted key 4308, and performs an analogous encryption of the symmetric key with the public keys associated with the remaining other users, up to User M (encrypted key 4310). Next, the encrypted keys are packaged with each of N shares 4312 of encrypted data set 4314, as part of the encrypted data at-rest, or packaged with the encrypted data in-motion as data packet headers or in a dedicated header packet of the encrypted data that is transmitted to storage depositories 4208a, 4208b and 4208c. When the cryptographic sharing client of a user device associated with User M, for example, attempts to retrieve and restore the data, the session key encrypted with User M's public key (encrypted key 4310) can be decrypted with the private key associated with User M, as described above with reference to User 2 device 4202b of FIGURE 42. In this manner, data may be securely shared with any number of users of secure sharing system 4200 by making an session key encrypted with a user's public key available to each user, along with the data encrypted with the session key. In preferred implementations, the session key is a symmetric key, or a symmetric key encrypted with a workgroup key.

[0525] In some implementations, the cryptographic sharing client used in secure sharing system 4200 may be configured to be interoperable with other clients, such as SPxClient (produced by Security First Corp. of Rancho Santa Margarita, California), for securing local data. In such implementations, SPxClient may be used to secure data locally, and the locally secured data may be securely shared using secure sharing system 4200. In some implementations, additional secure communication software such as SPxConnect (also produced by Security First Corp.) may be used to secure communications between a local machine and a web server or other server (e.g., between User 1 device 4202a and registration server 4210, or between User 1 device 4202a and storage depositories 4208a, 4208b and 4208c). In some implementations, the communications may be performed without the encryption key from the cryptographic sharing client by using a different key management system to create the secure connection. In some implementations, secure parsing software such as SPxBitFiler (also produced by Security First Corp.) may be used in enterprise settings, with data secured by SPxBitFiler shared using secure sharing system 4200.

[0526] In some implementations, use of secure sharing system 4200 may be subject to tiered pricing depending upon the level of use. For example, the pricing may be based on the size of the shared files. In some such implementations, each price tier is associated with a maximum file size which secure sharing system 4200 will handle for a user paying the tier price (e.g., 2 GB). In some such implementations, each price tier is associated with a range of the total

amount of data securely shared in a time period (e.g., a first price for 0-10 GB/month and a second price for 10-20 GB/month) or other suitable metric of volume of use (e.g., the number of files securely shared in a month). The tiered pricing may be based on the types of files shared (e.g., blobs or other file types). The tiered pricing may be based on the data throughput to the depositories in the cloud storage, with predetermined limits based on price paid or by varying the price charged based on the actual throughput. Secure sharing system 4200 may include a payment server configured to bill users and receive credit card payments or other electronic payments according to the tiered pricing.

[0527] FIGURE 44 is a flow diagram of illustrative steps of a method for securely sharing data. At step 4402, a processor (e.g., a processor associated with a first user device, such as User 1 device 4202a of FIGURE 42, configured with a cryptographic sharing client) generates an encrypted data set by encrypting a data set from a first user device (such as User 1 device 4202a of FIGURE 42) with a symmetric key. At step 4404, the processor generates a first encrypted key by encrypting data indicative of the symmetric key with a first asymmetric key (e.g., a public key) of a first asymmetric key pair associated with a first user device (such as User 1 device 4202a of FIGURE 42). In some implementations, step 4402 need not be performed by the processor and the method may begin with the encrypted data set and symmetric key at step 4404. At step 4406, the processor generates a second encrypted key by encrypting data indicative of the symmetric key with a first asymmetric key (e.g., a public key) of a second asymmetric key pair associated with a second user device (such as User 2 device 4202b of FIGURE 42). The first asymmetric key of the first and/or second asymmetric key pair may be accessed from a registration server (e.g., registration server 4210 of FIGURE 42). The data indicative of the symmetric key may be the symmetric key itself or the symmetric key encrypted with one or more keys for workgroups to which the second user device has access, for example. At step 4408, the processor forms two or more shares of the encrypted data set, each encrypted data set share including a portion of data from the encrypted data set generated at step 4402. At step 4410, the processor causes the first and second encrypted keys to be stored in at least one storage location and the two or more encrypted data set shares to be stored separately from each other in at least one storage location. The at least one storage location (e.g., a cloud storage location) is remote to both the first and second user devices. To restore the data set, a predetermined number of the two or more encrypted data set shares (e.g., 2 of 3) and at least one of the second asymmetric keys (e.g., a private key) of the first or second asymmetric key pair are needed.

[0528] In some implementations, the processor performs steps 4406 and 4410 for a plurality of user devices by generating a plurality of encrypted keys (step 4406) and causing the plurality of encrypted keys to be stored (step 4410). To do so, for each of a plurality of first asymmetric keys (e.g., the public keys) of a corresponding plurality of asymmetric key pairs associated with the plurality of user devices, the processor encrypts the data indicative of the symmetric key with the first asymmetric key to form the plurality of encrypted keys (step 4406). The processor then causes the plurality of encrypted keys to be stored in the at least one storage location (step 4410). In some implementations, the processor transmits the plurality of encrypted keys in a header of each of the two or more encrypted data set shares. To restore the data set, at least one of the plurality of second encryption keys (e.g., the private keys) of the plurality of asymmetric key pairs are needed, in addition to the predetermined number of the two or more encrypted data set shares.

[0529] FIGURE 45 is a flow diagram of illustrative sub-steps that a processor may perform in the course of performing step 4410 of FIGURE 44, in which the processor causes the encrypted keys to be stored in at least one storage location. At step 4502, the processor forms two or more shares of the first and second encrypted key. The first and second encrypted keys may be formed into shares separately, or combined and then formed into shares. Each encrypted key share includes a portion of data from the encrypted key. At step 4504, the processor causes the two or more encrypted key shares to be stored separately from each other in the at least one storage location (discussed above with reference to FIGURE 44). To restore the encrypted keys, a predetermined number of the two or more encrypted key shares (e.g., 3 of 4) is needed.

[0530] FIGURE 46 is a flow diagram of illustrative steps of a method for accessing a data set shared securely according to the method illustrated in FIGURE 44. At step 4602, a processor accesses an encrypted key and a predetermined number of encrypted data set shares stored in at least one storage location. The encrypted key comprises data indicative of a symmetric key encrypted with a first asymmetric key (e.g., a public key) of a first asymmetric key pair associated with a first user device (e.g., User 2 device 4202b of FIGURE 42). The first asymmetric key may have been previously provided to a registration server (e.g., registration server 4210 of FIGURE 42). The encrypted data set shares were encrypted with the symmetric key by a second user device different from the first user device (e.g., User 1 device 4202a of FIGURE 42). A first asymmetric key of a second asymmetric key pair associated with the second user device is also stored at the at least one storage location. The at least one storage location is remote from the first and second user devices. At step 4604,

the processor restores the data indicative of the symmetric key by decrypting the encrypted key using a second asymmetric key (e.g., a private key) of the asymmetric key pair. At step 4606, the processor restores the encrypted data set from the predetermined number of encrypted data set shares (accessed at step 4602) and the data indicative of the symmetric key.

[0531] FIGURE 47 is a flow diagram of illustrative steps of a method for securely sharing data. An implementation of the method of FIGURE 47 is discussed above with reference to FIGURE 43. Steps of the flow diagram of FIGURE 47 that are similar to steps of the flow diagram of FIGURE 44 may be performed in a similar manner. At step 4702, a processor (e.g., a processor associated with a first user device, such as User 1 device 4202a of FIGURE 42, configured with a cryptographic sharing client) generates an encrypted data set by encrypting a data set from a first user device with a symmetric key. At step 4704, the processor forms two or more shares of the encrypted data set, each encrypted data set share including a portion of data from the encrypted data set (generated at step 4702). In some implementations, step 4702 need not be performed by the processor and the method may begin with the encrypted data set and symmetric key at step 4704. At step 4706, for each of a plurality of user devices, including the first user device, the processor generates an encrypted key by encrypting data indicative of the symmetric key with a first asymmetric key of an asymmetric key pair associated with the user device. At step 4708, for each of the two or more encrypted data set shares, the processor distributes the plurality of encrypted keys in a header of the encrypted data set share. At step 4710, the processor causes the two or more encrypted data set shares and headers to be stored in at least one storage location. To restore the data set, a predetermined number of the two or more encrypted data set shares and a second asymmetric key of at least one of the plurality of asymmetric key pairs are needed.

[0532] Those skilled in the art will realize that secure sharing may be realized by secure sharing systems that are modifications or variations of the systems described above. Thus, inasmuch as implementations have been described with respect to the secure sharing system of FIGURE 42, these implementations are intended to be illustrative and not limiting of the present invention.

[0533] The term “comprise” and variants of that term such as “comprises” or “comprising” are used herein to denote the inclusion of a stated integer or integers but not to exclude any other integer or any other integers, unless in the context or usage an exclusive interpretation of the term is required.

CLAIMS

1. A method for securely sharing data, the method steps implemented by a programmed computer system, comprising:
 - forming two or more shares of an encrypted data set, the encrypted data set representative of a data set associated with a first user device and encrypted with a symmetric key, and each encrypted data set share comprising a portion of data from the encrypted data set;
 - causing the two or more encrypted data set shares to be stored separately from each other in at least one storage location;
 - generating a first encrypted key by encrypting data indicative of the symmetric key with a first asymmetric key of a first asymmetric key pair, the first asymmetric key pair associated with the first user device;
 - generating a second encrypted key by encrypting data indicative of the symmetric key with a first asymmetric key of a second asymmetric key pair, the second asymmetric key pair associated with a second user device; and
 - causing the first and second encrypted keys to be stored in the at least one storage location, wherein the at least one storage location is remote to both the first and second user devices and wherein a predetermined number of the two or more encrypted data set shares and at least one of a second asymmetric key of the first asymmetric key pair and a second asymmetric key of the second asymmetric key pair are needed to restore the data set.
2. The method of claim 1, wherein the data indicative of the symmetric key is the symmetric key.
3. The method of claim 1, wherein the data indicative of the symmetric key is the symmetric key encrypted with a workgroup key, and wherein the workgroup key is needed to restore the data set.
4. The method of claim 3, wherein the second user device is associated with a workgroup that has access to the workgroup key.

5. The method of claim 1, further comprising:
forming two or more shares of the first and second encrypted keys, each encrypted key share comprising a portion of data from the first and second encrypted keys, wherein causing the first and second encrypted keys to be stored in the at least one storage location comprises causing the two or more encrypted key shares to be stored separately from each other in the at least one storage location, and wherein a predetermined number of the two or more encrypted key shares is needed to restore the first and second encrypted keys.
6. The method of claim 1, further comprising:
accessing the first asymmetric key of the second asymmetric key pair from a registration server prior to generating the second encrypted key.
7. The method of claim 1, further comprising:
generating a plurality of encrypted keys by, for each of a plurality of first asymmetric keys of a corresponding plurality of asymmetric key pairs associated with a corresponding plurality of user devices, encrypting the data indicative of the symmetric key with the first asymmetric key; and
causing the plurality of encrypted keys to be stored in the at least one storage location, wherein the predetermined number of the two or more encrypted data set shares and at least one of the second asymmetric key of the first asymmetric key pair, the second asymmetric key of the second asymmetric key pair, and the plurality of second encryption keys of the plurality of asymmetric key pairs are needed to restore the data set.
8. The method of claim 7, wherein causing the plurality of encrypted keys to be stored in the at least one storage location comprises transmitting the plurality of encrypted keys in a header of each of the two or more encrypted data set shares.
9. A method for accessing a securely shared data set, the method steps implemented by a programmed computer system, comprising:
accessing a first encrypted key stored in at least one storage location, wherein the first encrypted key comprises data indicative of a symmetric key encrypted with a first asymmetric key of a first asymmetric key pair associated with a first user device, wherein the at least one storage location is remote from the first user device and remote from a second user device different from the first user device, and wherein the at least one storage location also stores a

second encrypted key comprising data indicative of the symmetric key encrypted with a first asymmetric key of a second asymmetric key pair associated with the second user device;

restoring the data indicative of the symmetric key by decrypting the first encrypted key using a second asymmetric key of the first asymmetric key pair;

accessing a predetermined number of two or more encrypted data set shares stored in the at least one storage location, the encrypted data set shares encrypted with the symmetric key by the second user device; and

restoring the data set using the predetermined number of encrypted data set shares and the data indicative of the symmetric key.

10. The method of claim 9, wherein the data indicative of the symmetric key is the symmetric key.

11. The method of claim 9, wherein the data indicative of the symmetric key is the symmetric key encrypted with a workgroup key, and wherein the workgroup key is used to restore the data set.

12. The method of claim 11, wherein the first user device is associated with a workgroup that has access to the workgroup key

13. The method of claim 9, further comprising:
providing the first asymmetric key of the first asymmetric key pair to a registration server prior to accessing the first encrypted key.

14. A method for securely sharing data, the method steps implemented by a programmed computer system, comprising:

forming two or more shares of an encrypted data set, the encrypted data set representative of a data set associated with a first user device and encrypted with a symmetric key, and each encrypted data set share comprising a portion of data from the encrypted data set;

for each of a plurality of user devices including the first user device, generating an encrypted key by encrypting data indicative of the symmetric key with a first asymmetric key of an asymmetric key pair associated with the user device;

for each of the two or more encrypted data set shares, distributing the plurality of encrypted keys in a header of the encrypted data set share; and

causing the two or more encrypted data set shares and headers to be stored in at least one storage location, wherein a predetermined number of the two or more encrypted data set shares and a second asymmetric key of at least one of the plurality of asymmetric key pairs are needed to restore the data set.

15. The method of claim 14, wherein the data indicative of the symmetric key is the symmetric key.
16. The method of claim 14, wherein the data indicative of the symmetric key is the symmetric key encrypted with a workgroup key, and wherein the workgroup key is needed to restore the data set.
17. The method of claim 16, wherein the plurality of user devices are each associated with a workgroup that has access to the workgroup key
18. The method of claim 14, further comprising:
accessing at least some of the plurality of first asymmetric keys from a registration server prior to generating the plurality of encrypted keys.
19. The method of any one of claims 1-18, wherein the at least one storage location comprises a cloud computing storage location.
20. A computer system for securely sharing data, comprising:
at least one processor configured to perform the method according to any one of claims 1-19.
21. A non-transitory computer-readable medium storing computer-executable instructions which, when executed by at least one processor, cause a computer system to carry out the method of any one of claims 1-19.

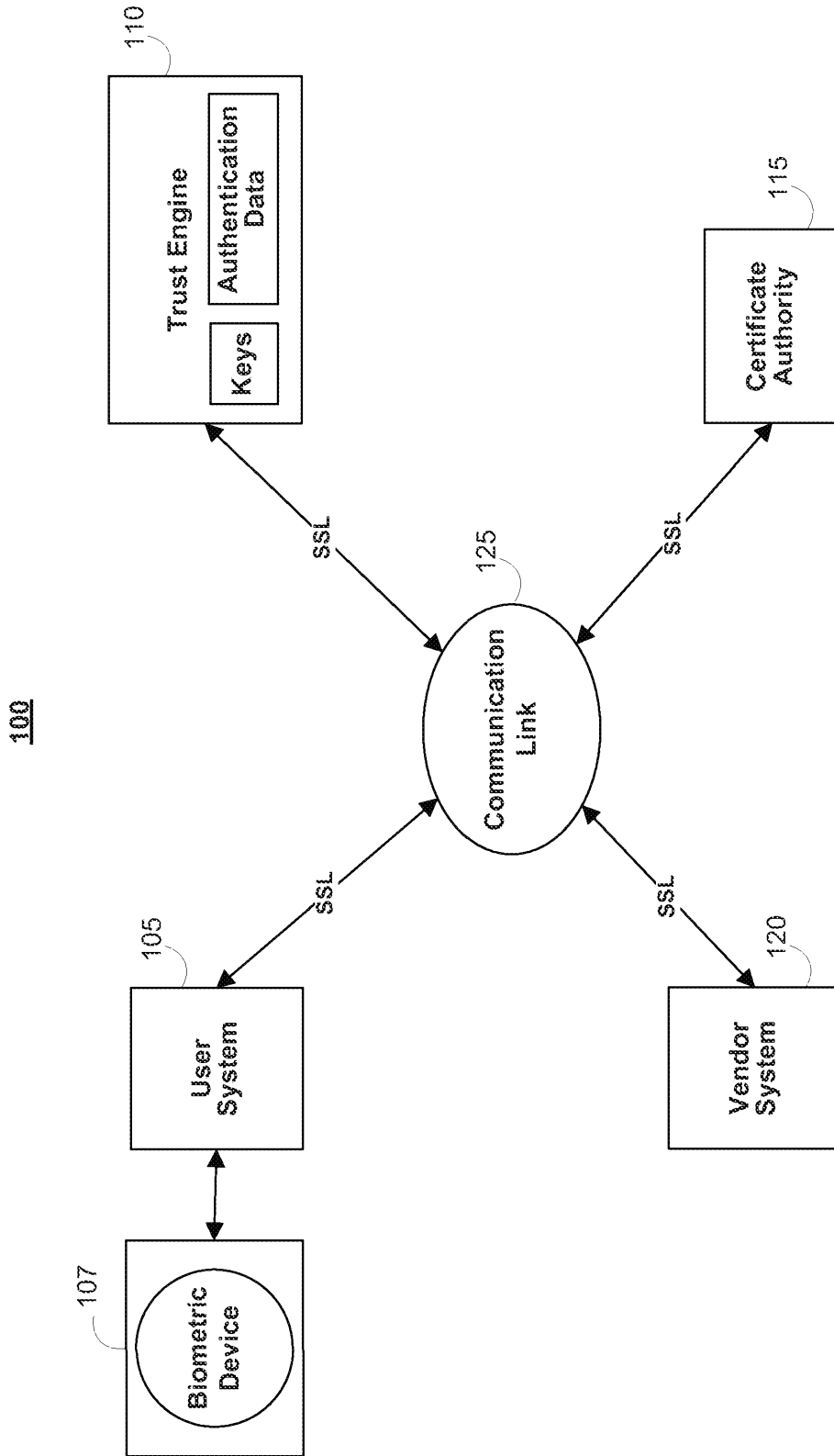

FIG. 1

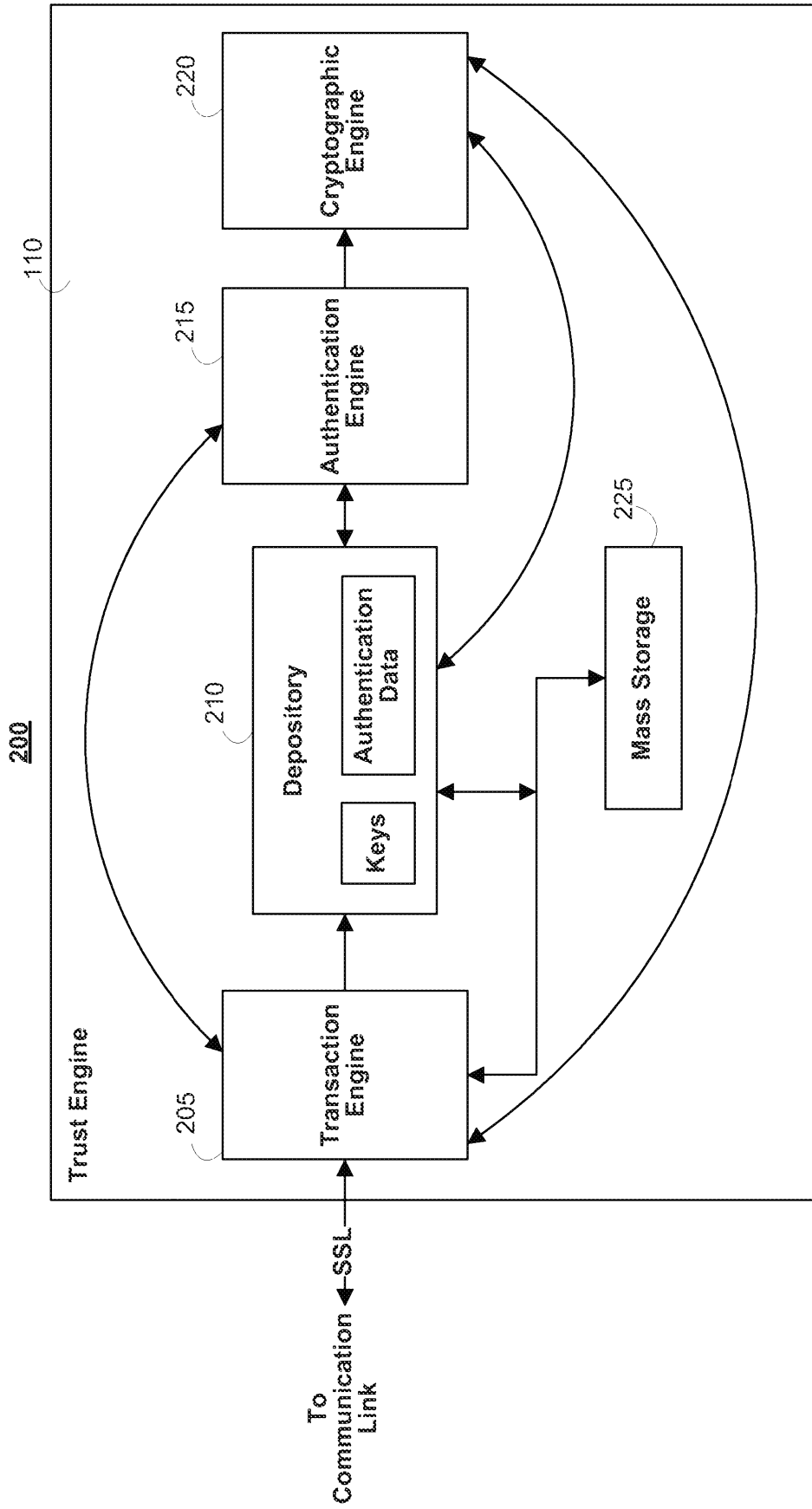

FIG. 2

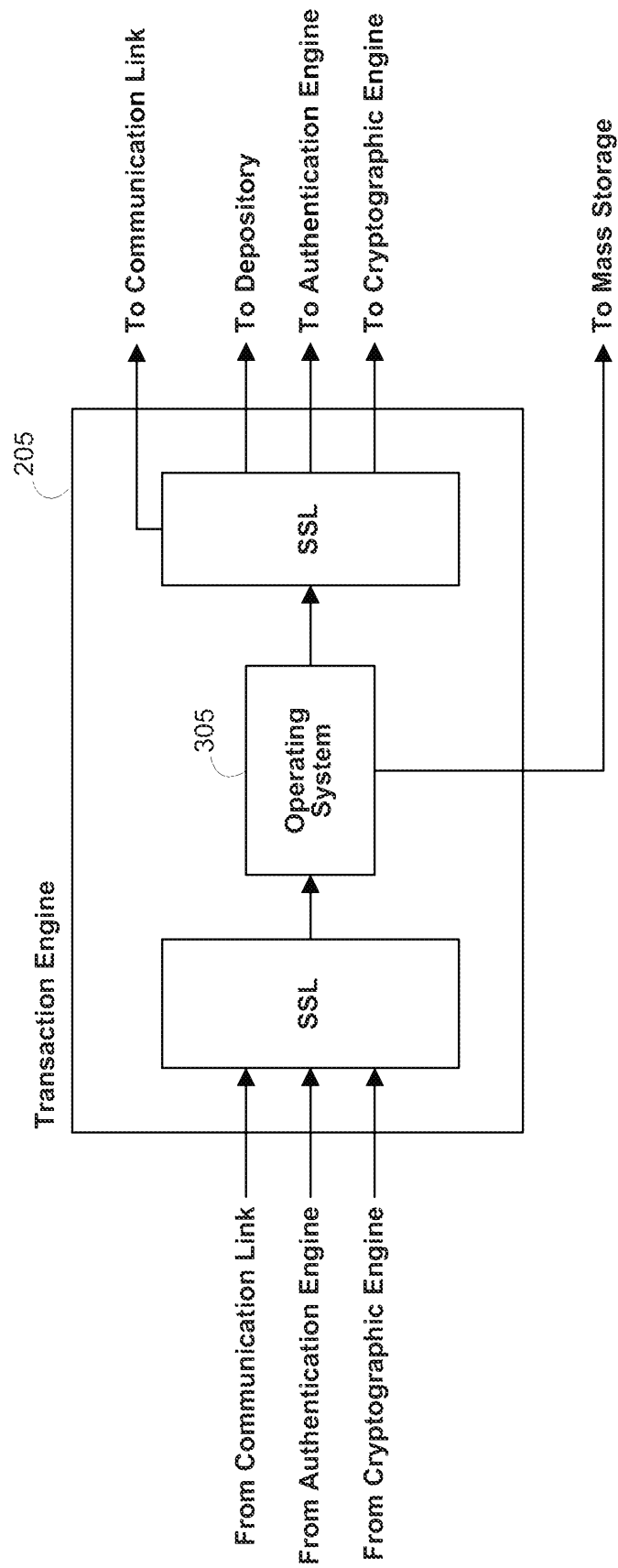

FIG. 3

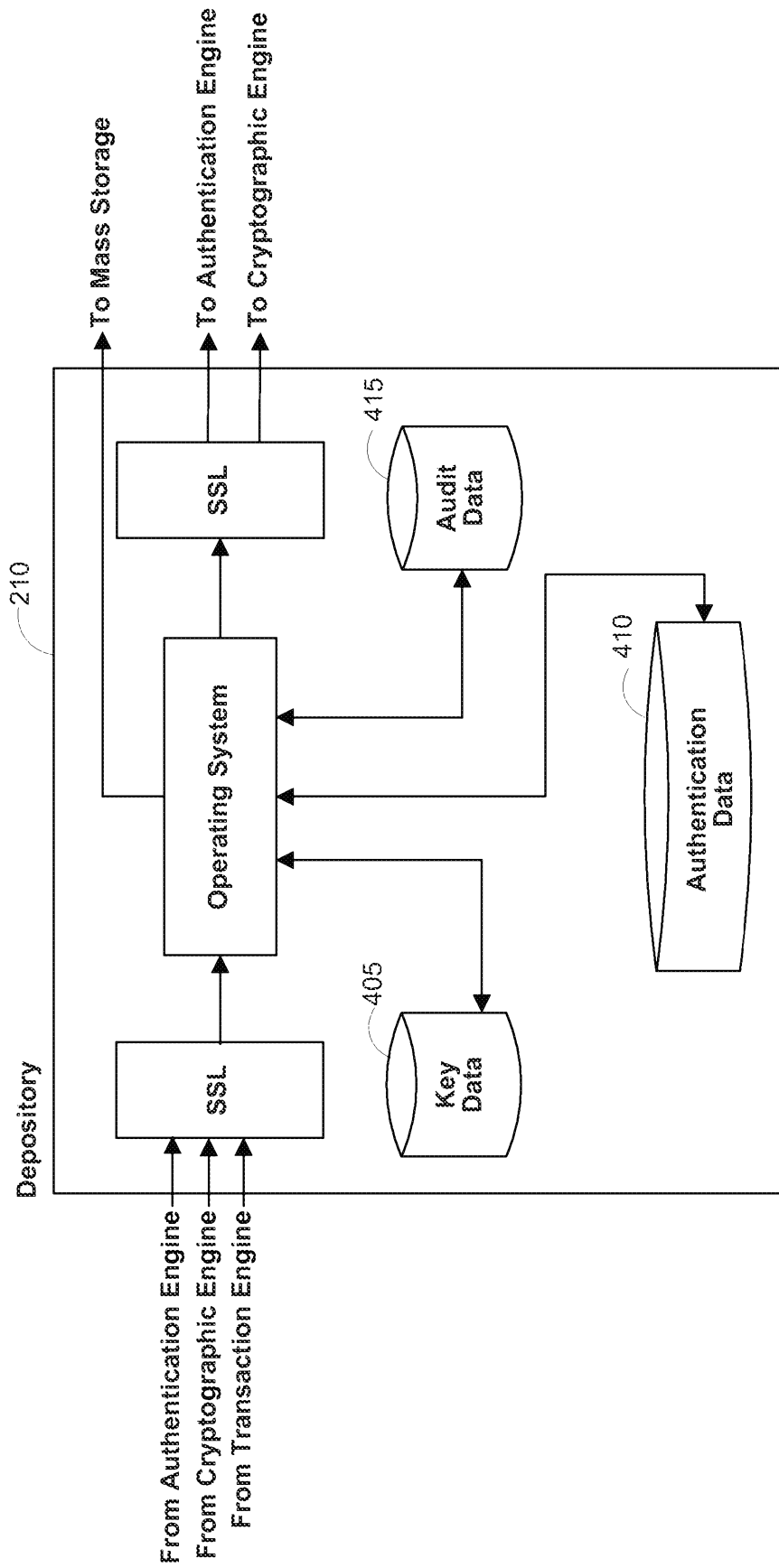

FIG. 4

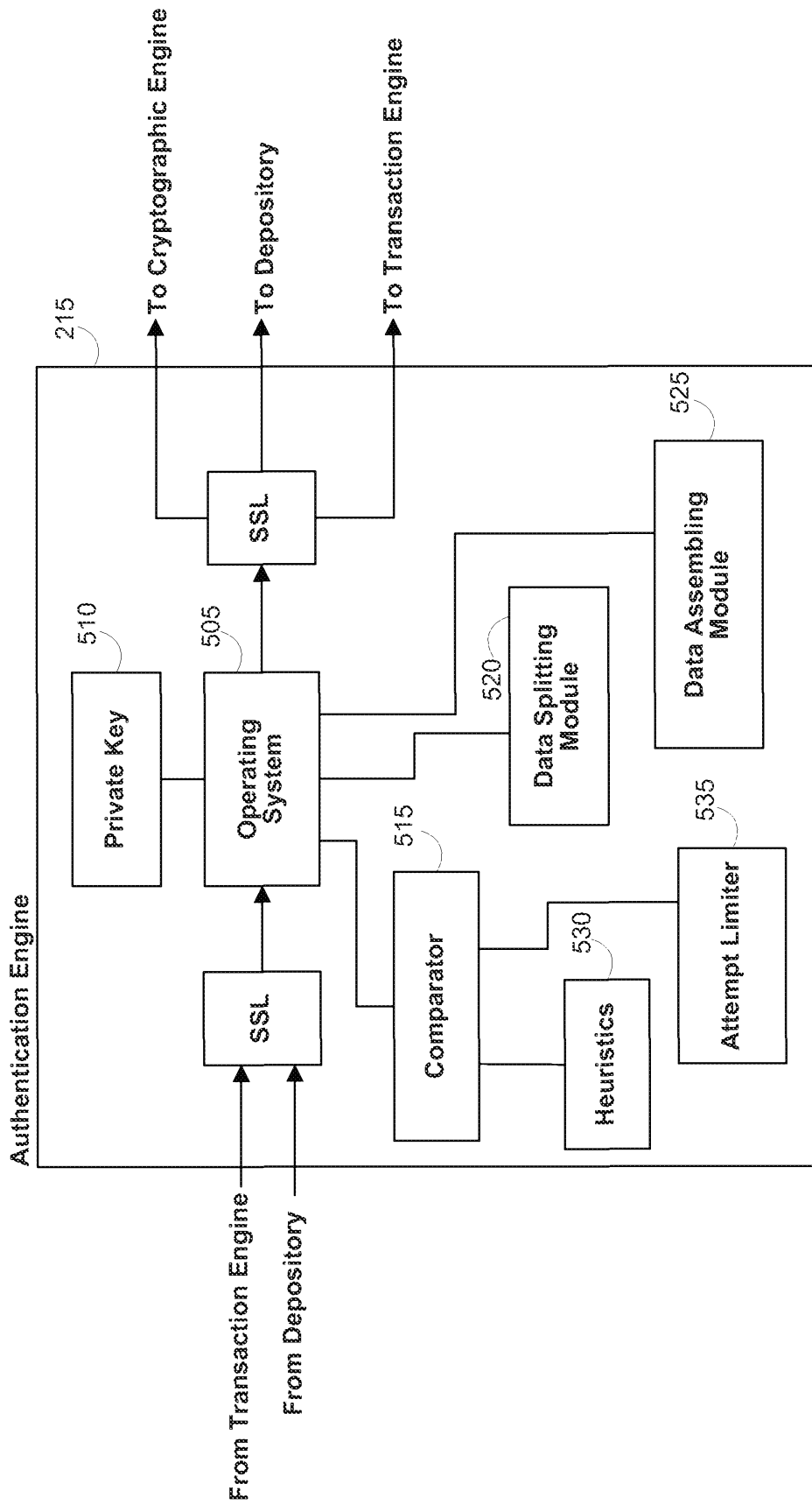

FIG. 5

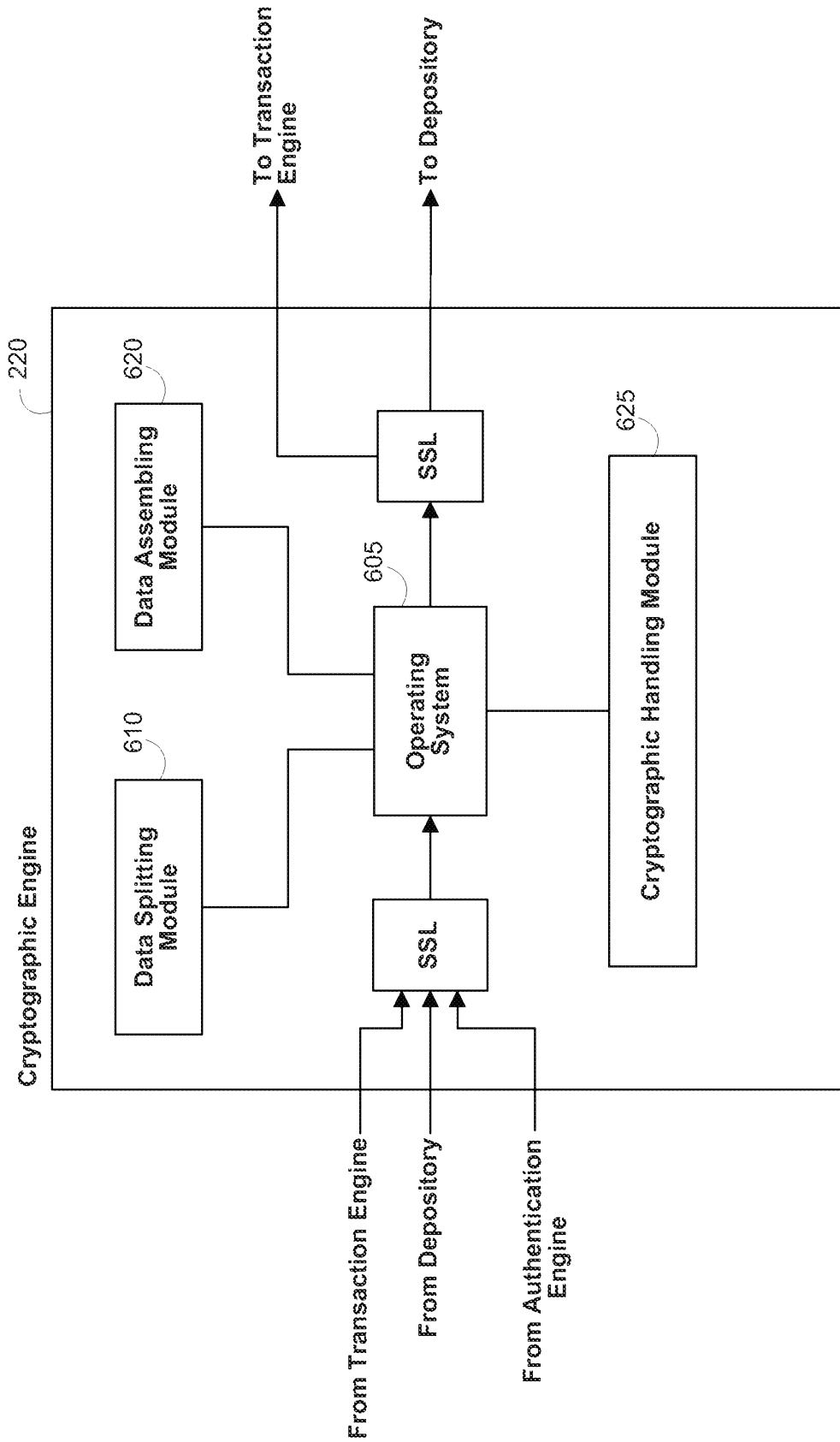

FIG. 6

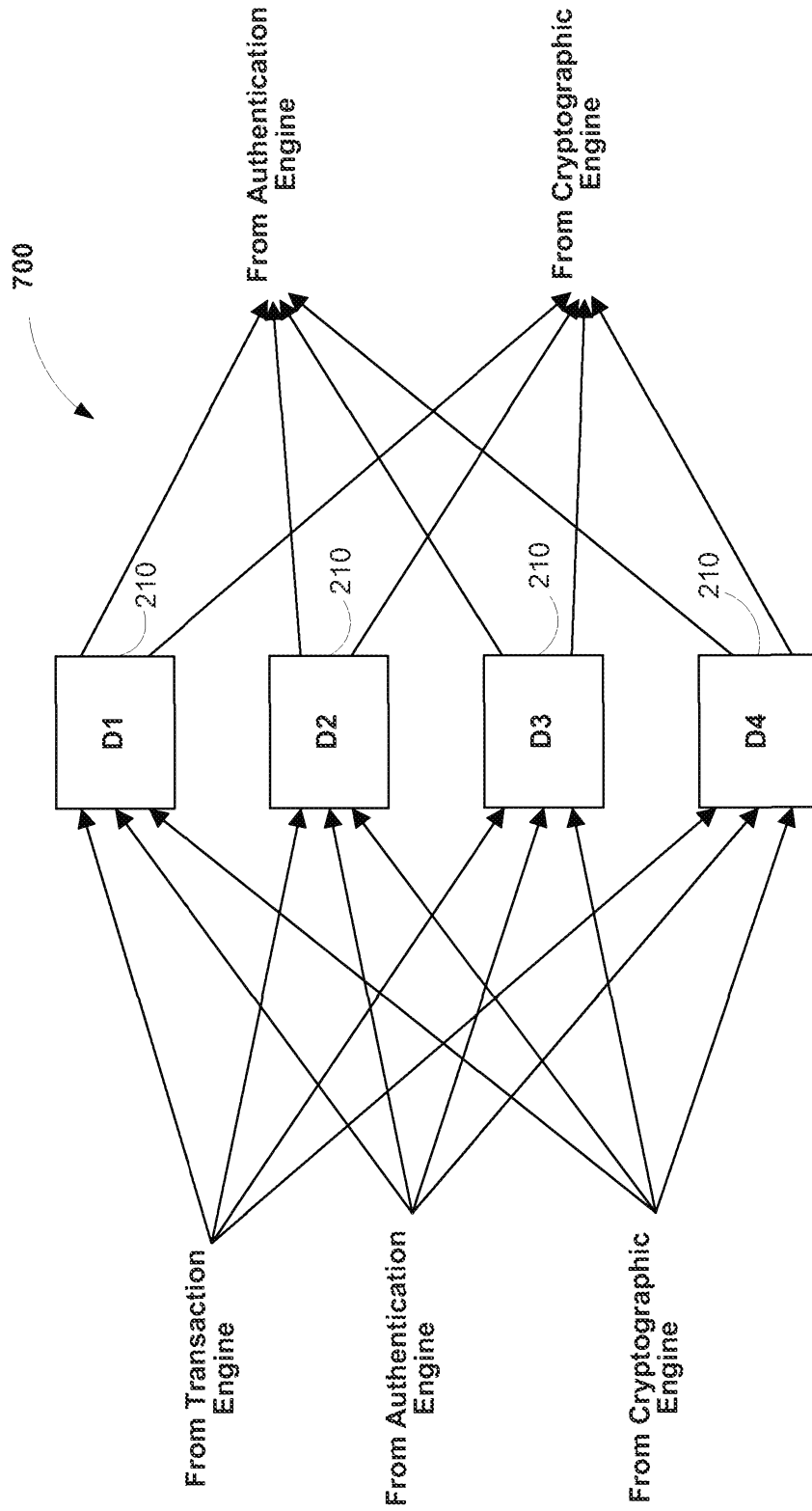

FIG. 7

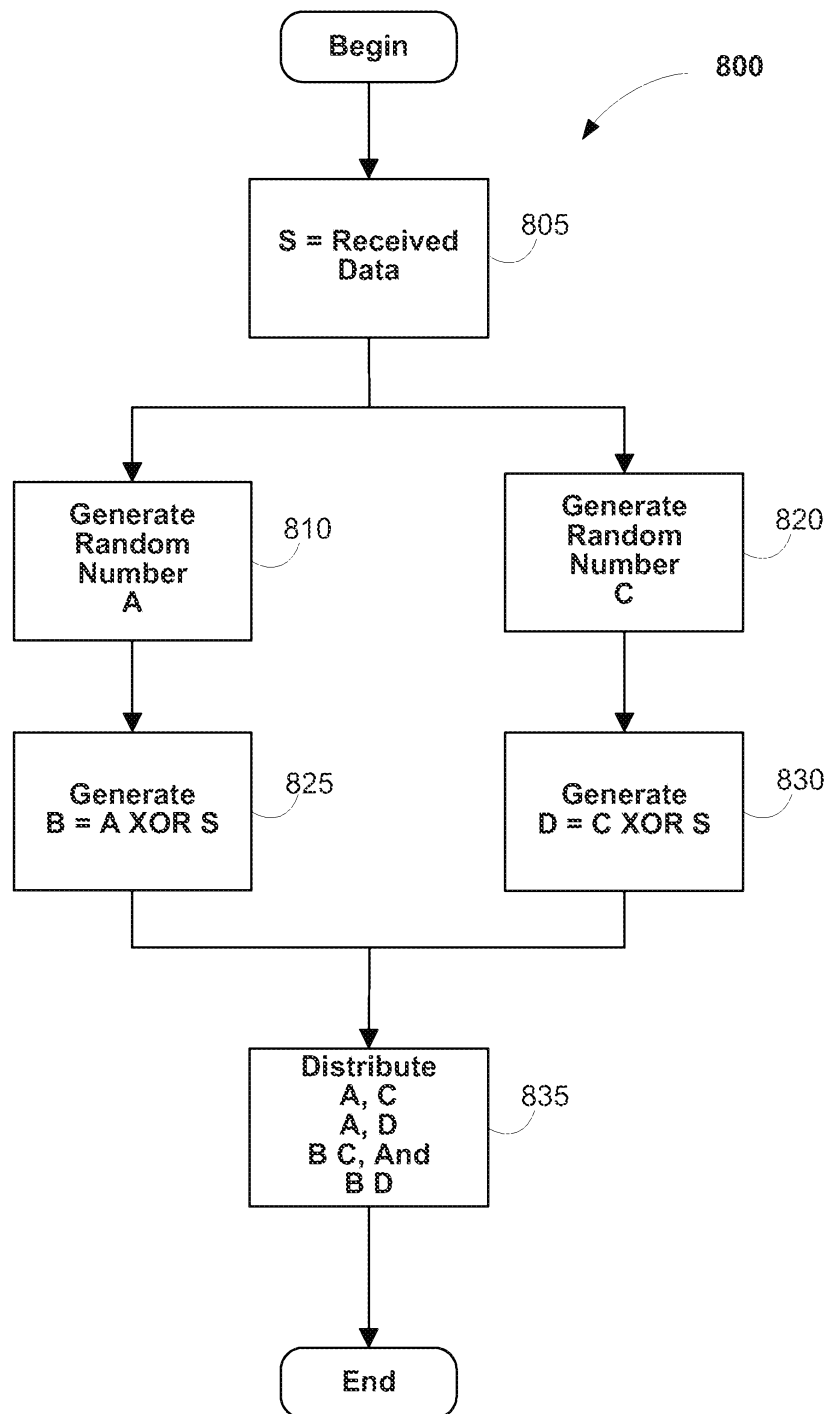

FIG. 8

900

Enrollment Data Flow			
Send	Receive	SSL	Action
User	Transaction Engine (TE)	1/2	Transmit Enrollment Authentication Data (B) and the User ID (UID) encrypted with the Public Key of the Authentication Engine (AE) as (PUB_AE(UID,B))
TE	AE	Full	Forward Transmission
			AE Decrypts and Splits Forwarded Data
AE	The Xth Depository (DX)	Full	Store Respective Portion of Data
When Digital Certificate Requested			
AE	Cryptographic Engine (CE)	Full	Request Key Generation
			CE Generates and Splits Key
CE	TE	Full	Transmit Request for Digital Certificate
TE	Certification Authority (CA)	1/2	Transmit Request
CA	TE	1/2	Transmit Digital Certificate
TE	User	1/2	Transmit Digital Certificate
TE	MS	Full	Store Digital Certificate
CE	DX	Full	Store Respective Portion of Key

FIG. 9, Panel A

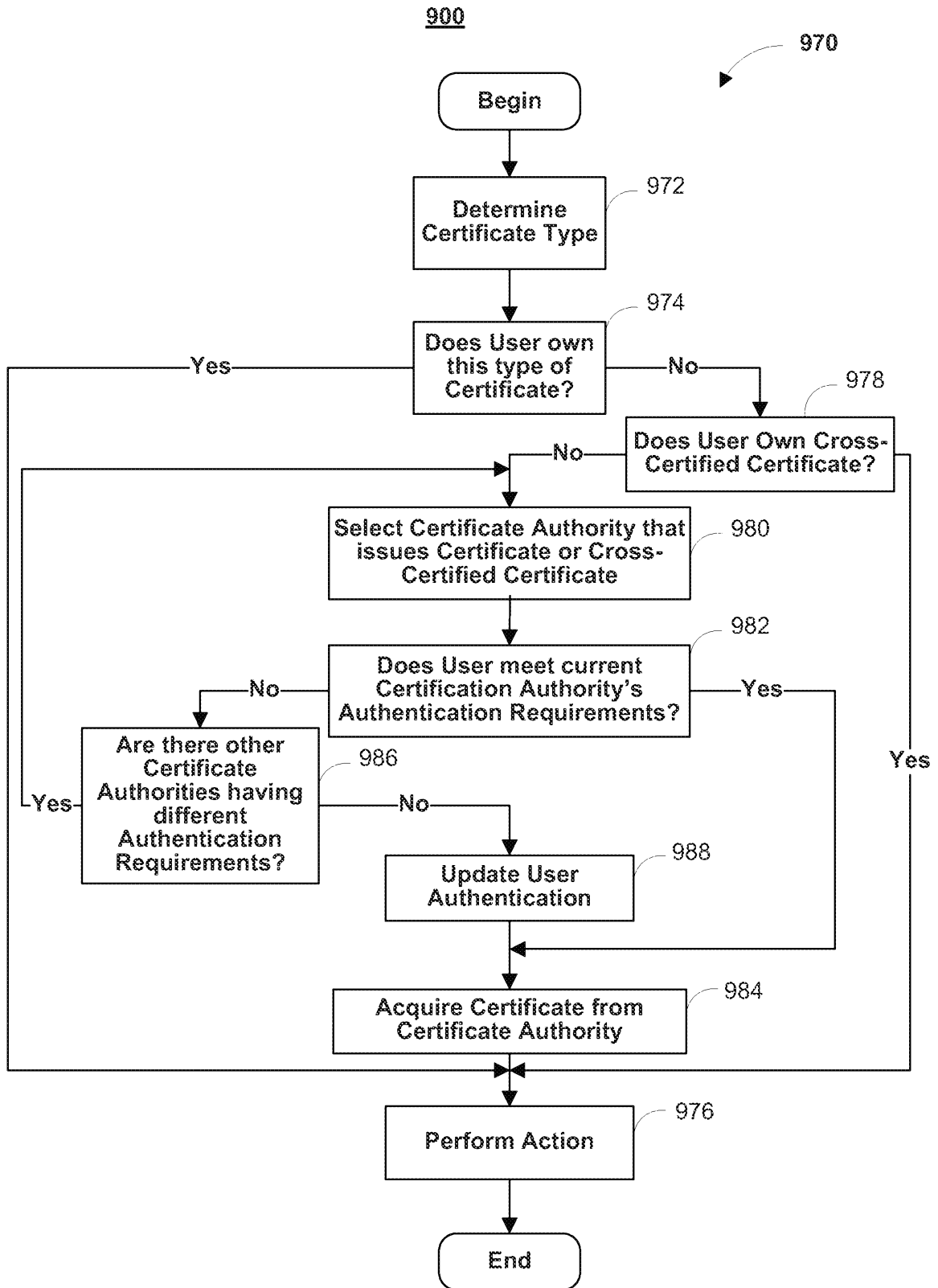

FIG. 9, Panel B

1000
▼

Authentication Data Flow			
SEND	RECEIVE	SSL	ACTION
1005 User	Vendor	1/2	Transaction occurs, such as selecting purchase
1010 Vendor	User	1/2	Transmit transaction ID (TID) and authentication request (AR)
			Authentication data (B') is gathered from User
1015 User	TE	1/2	Transmit TID and B' wrapped in the Public Key of the Authentication Engine (AE), as (PUB_AE(TID, B'))
1020 TE	AE	Full	Forward transmission
			Enrollment authentication data (B) is requested and gathered
1025 Vendor	Transaction Engine (TE)	Full	Transmits TID, AR
1030 TE	Mass Storage (MS)	Full	Create Record in database
1035 TE	The Xth Depository (DX)	Full	UID, TID
1040 DX	AE	Full	Transmit the TID and the portion of the authentication data stored at enrollment (BX) as (PUB_AE(TID, BX))
			AE assembles B and compares to B'
1050 AE	TE	Full	TID, the filled in AR
1055 TE	Vendor	Full	TID, Yes/No
TE	User	1/2	TID, confirmation message

FIG. 10

1100
▼

Signing Data Flow				
SEND	RECEIVE	SSL	ACTION	
User	Vendor	1/2	Transaction occurs, such as agreeing on a deal	
Vendor	User	1/2	Transmit transaction identification number (TID), authentication request (AR), and agreement or message (M)	
			Current authentication data (B') and a hash of the message received by the User (h(M')) is gathered from User	
User	TE	1/2	Transmit TID, B', AR, and h(M') wrapped in the Public Key of the Authentication Engine (AE), as (PUB_AE(TID, B', h(M')))	
TE	AE	Full	Forward transmission	
			Gather enrollment authentication data	
Vendor	Transaction Engine (TE)	Full	Transmits UID, TID, AR, and a hash of the message (h(M')).	
TE	Mass Storage (MS)	Full	Create Record in database	
TE	The Xth Depository (DX)	Full	UID, TID	
DX	AE	Full	Transmit the TID and the portion of the authentication data stored at Enrollment (BX), as (PUB_AE(TID, BX))	
			The original vendor message is transmitted to the AE	
TE	AE	Full	Transmit h(M)	
1103	AE assembles B, compares to B' and compares h(M) to h(M')			
1105	AE	Cryptographic Engine (CE)	Full	Request for digital signature and a message to be signed, for example, the hashed message
1110	AE	DX	Full	TID, signing UID
1115	DX	CE	Full	Transmit the portion of the Cryptographic Key corresponding to the signing party
1120	CE assembles key and signs			
1125	CE	AE	Full	Transmit the digital signature (S) of signing party
1130	AE	TE	Full	TID, the filled in AR, h(M), and S
1135	TE	Vendor	Full	TID, a receipt=(TID, Yes/No, and S), and the digital signature of the trust engine, for example, a hash of the receipt encrypted with the trust engine's Private Key (Priv_TE(h(receipt)))
1140	TE	User	1/2	TID, confirmation message

FIG. 11

1200
▼

Encryption/Decryption Data Flow			
Send	Receive	SSL	Action
Decryption			
			Perform Authentication Data Process 1000, include the Session Key (sync) in the AR, where the sync has been encrypted with the Public Key of the User as PUB_USER(SYNC)
			Authenticate the User
AE	CE	Full	Forward PUB_USER(SYNC) to CE
AE	DX	Full	UID, TID
DX	CE	Full	Transmit the TID and the portion of the Private Key as (PUB_AE(TID, KEY_USER))
			CE assembles the Cryptographic Key and decrypts the sync
CE	AE	Full	TID, the filled in AR including decrypted sync
AE	TE	Full	Forward to TE
TE	Requesting APP/Vendor	1/2	TID, Yes/No, Sync
Encryption			
Requesting APP/Vendor	TE	1/2	Request for Public Key of User
TE	MS	Full	Request Digital Certificate
MS	TE	Full	Transmit Digital Certificate
TE	Requesting APP/Vendor	1/2	Transmit Digital Certificate

FIG. 12

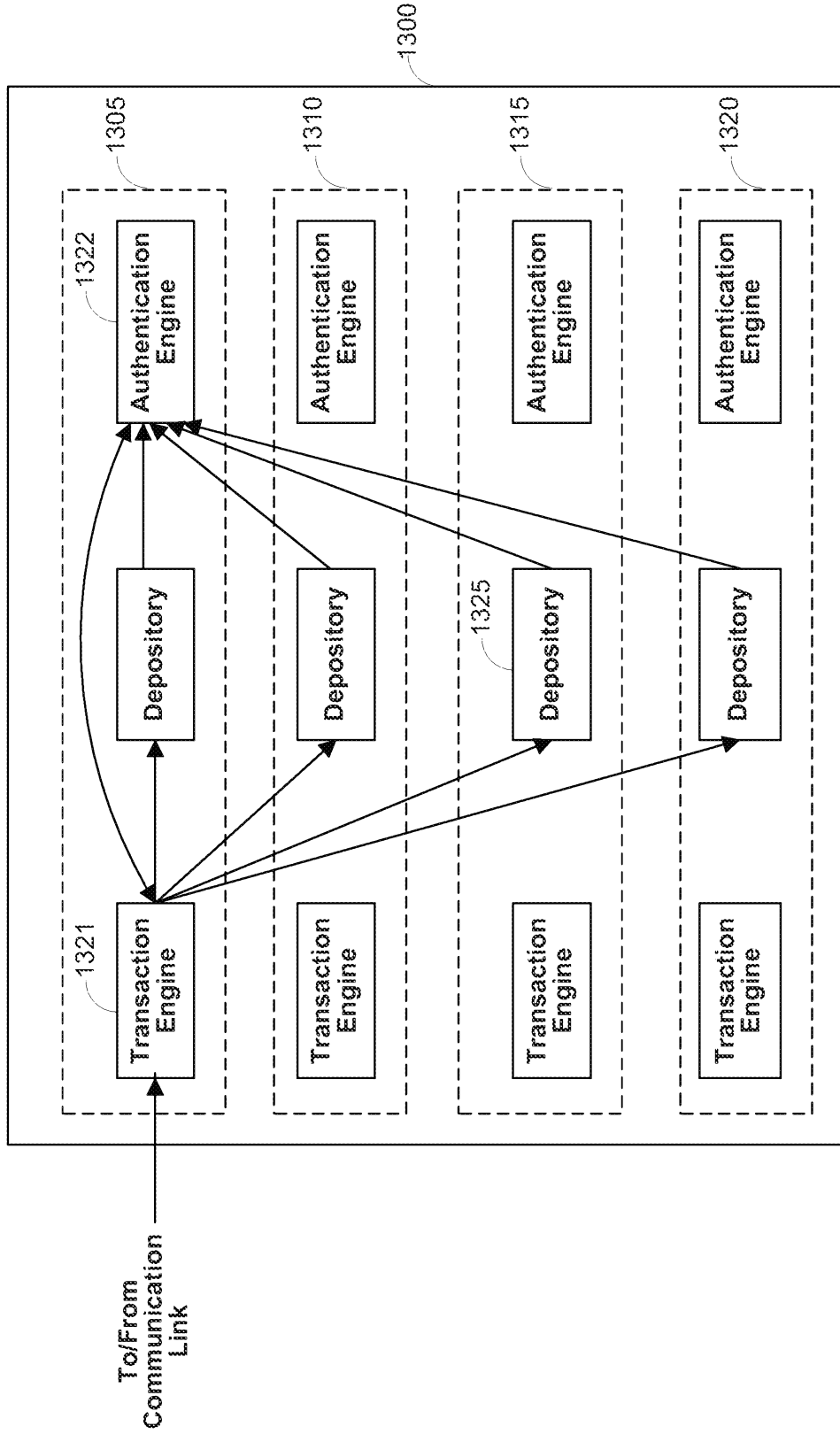

FIG. 13

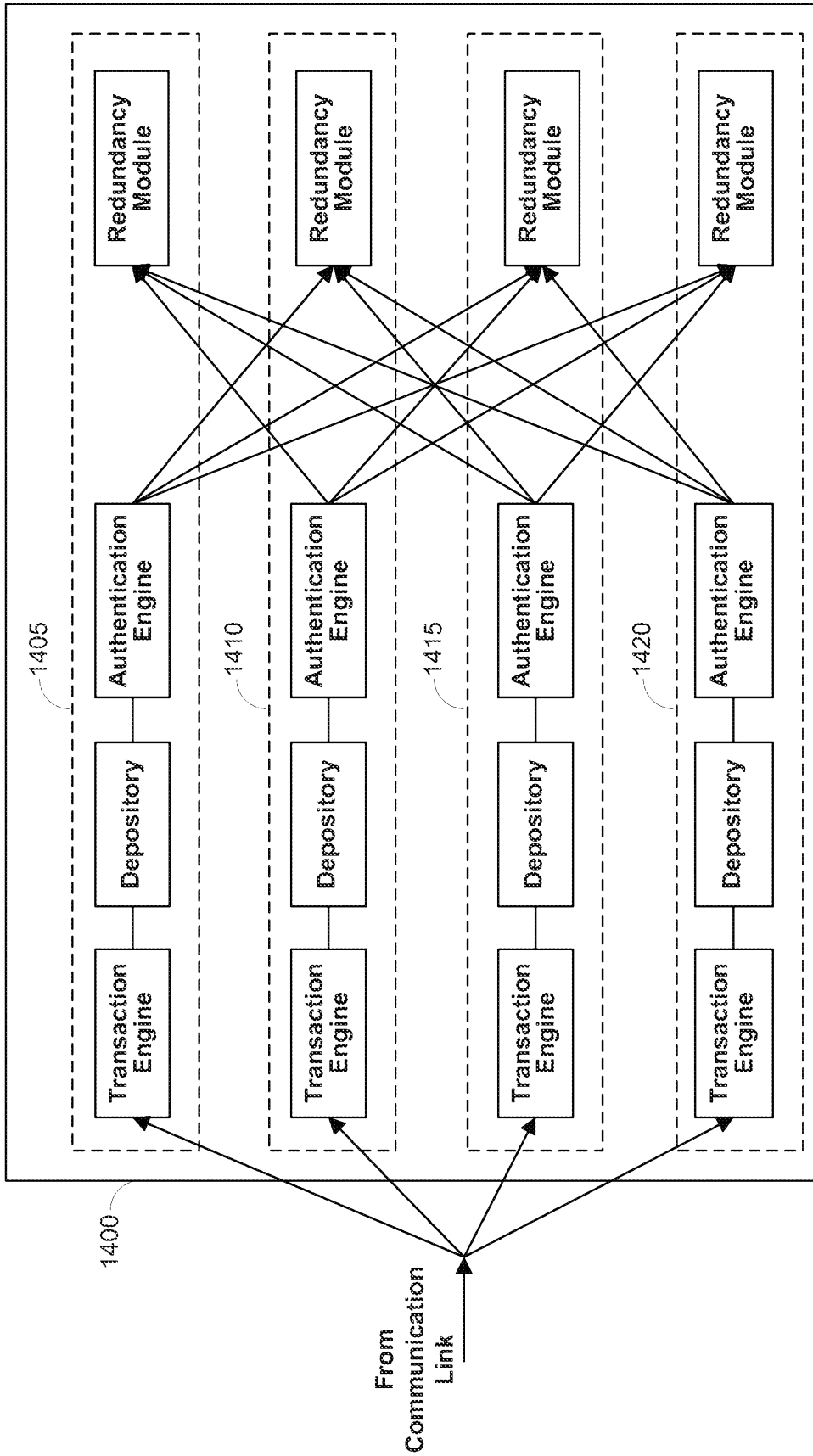

FIG. 14

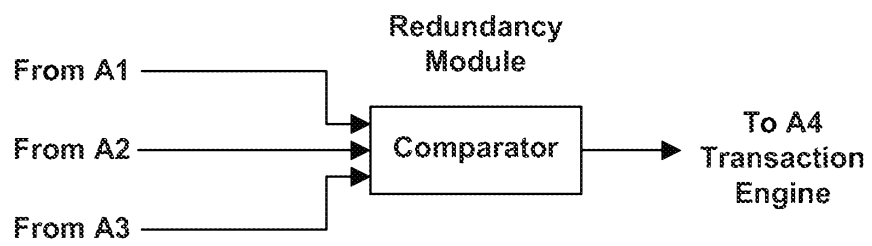

FIG. 15

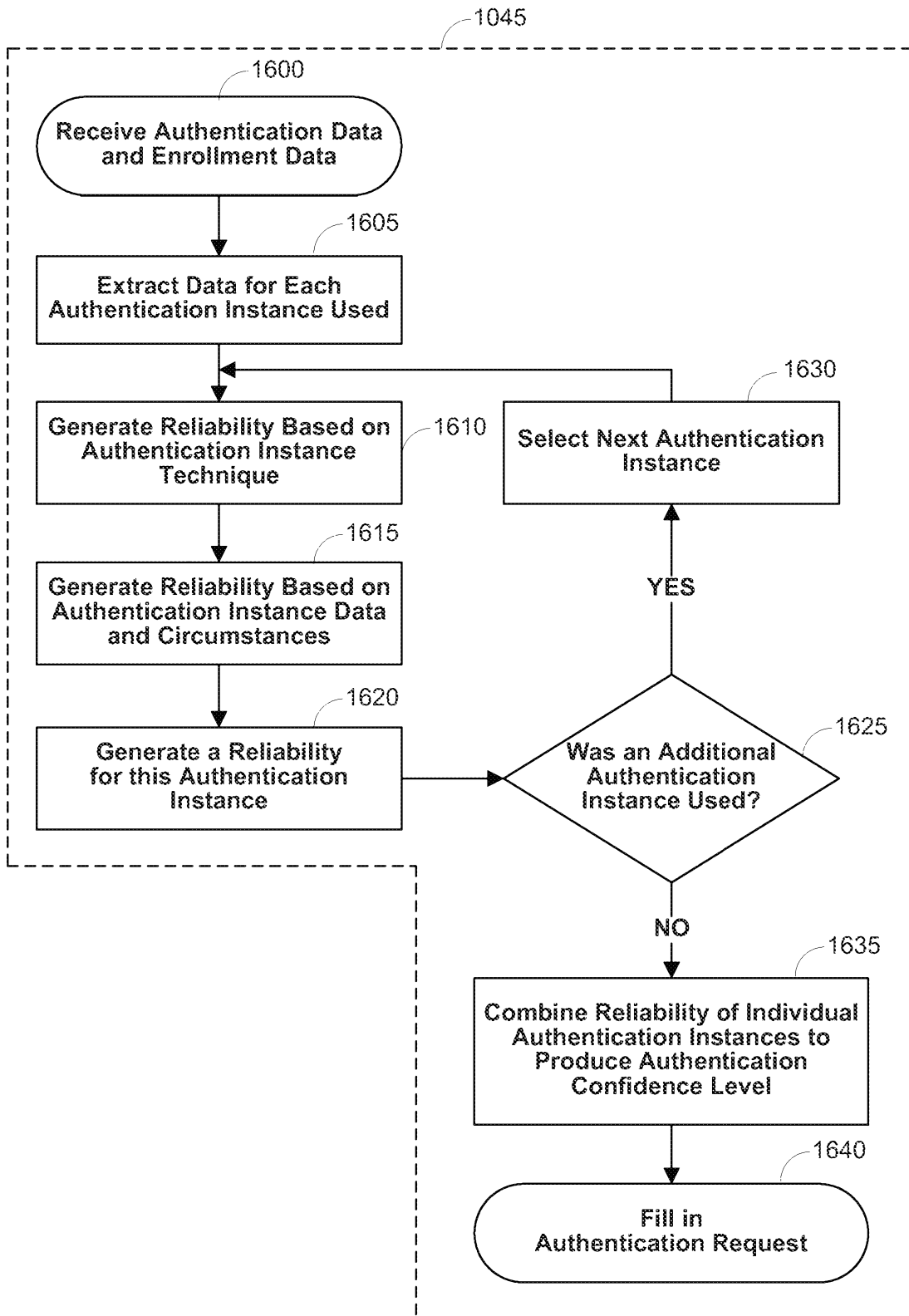

FIG. 16

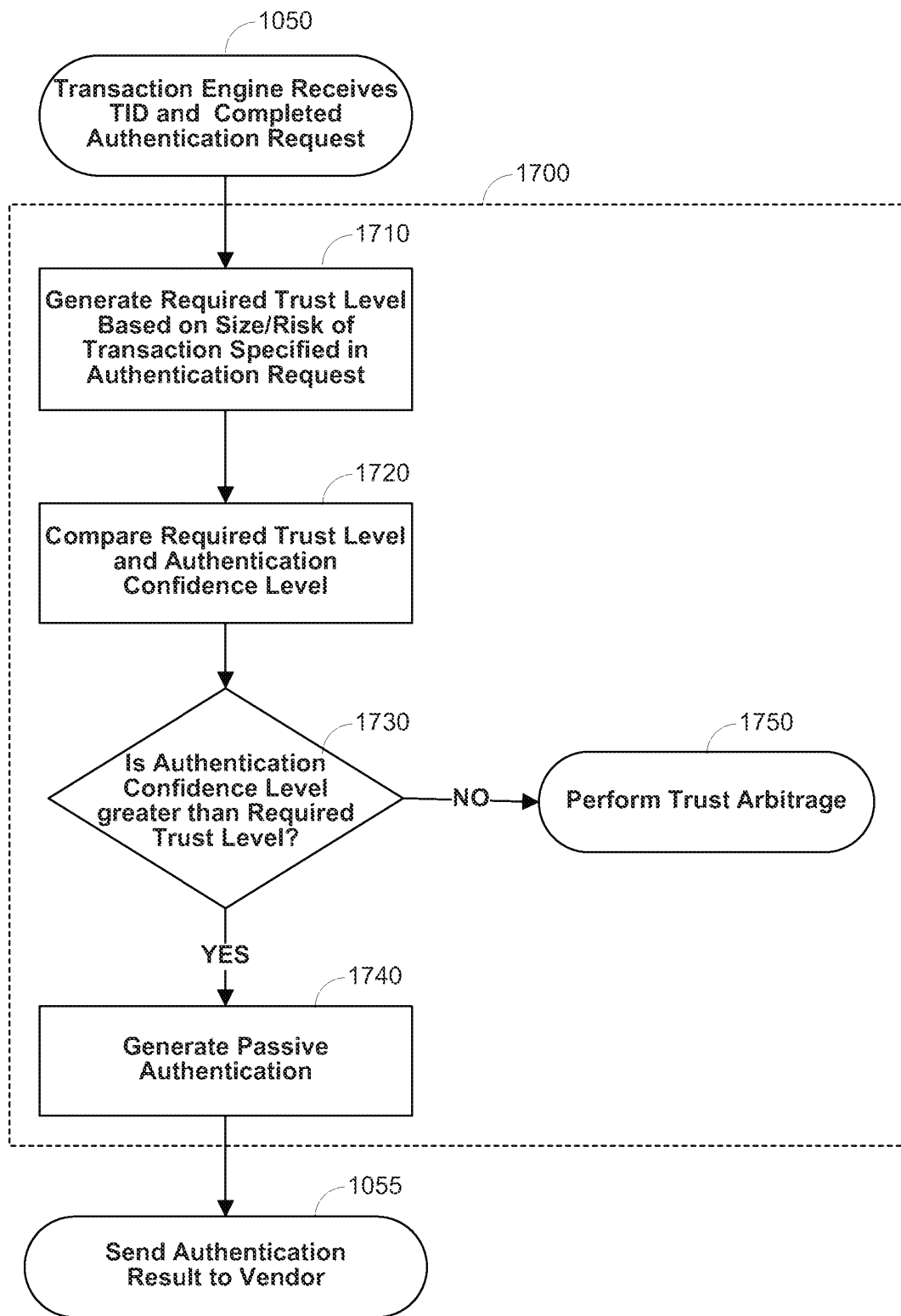

FIG. 17

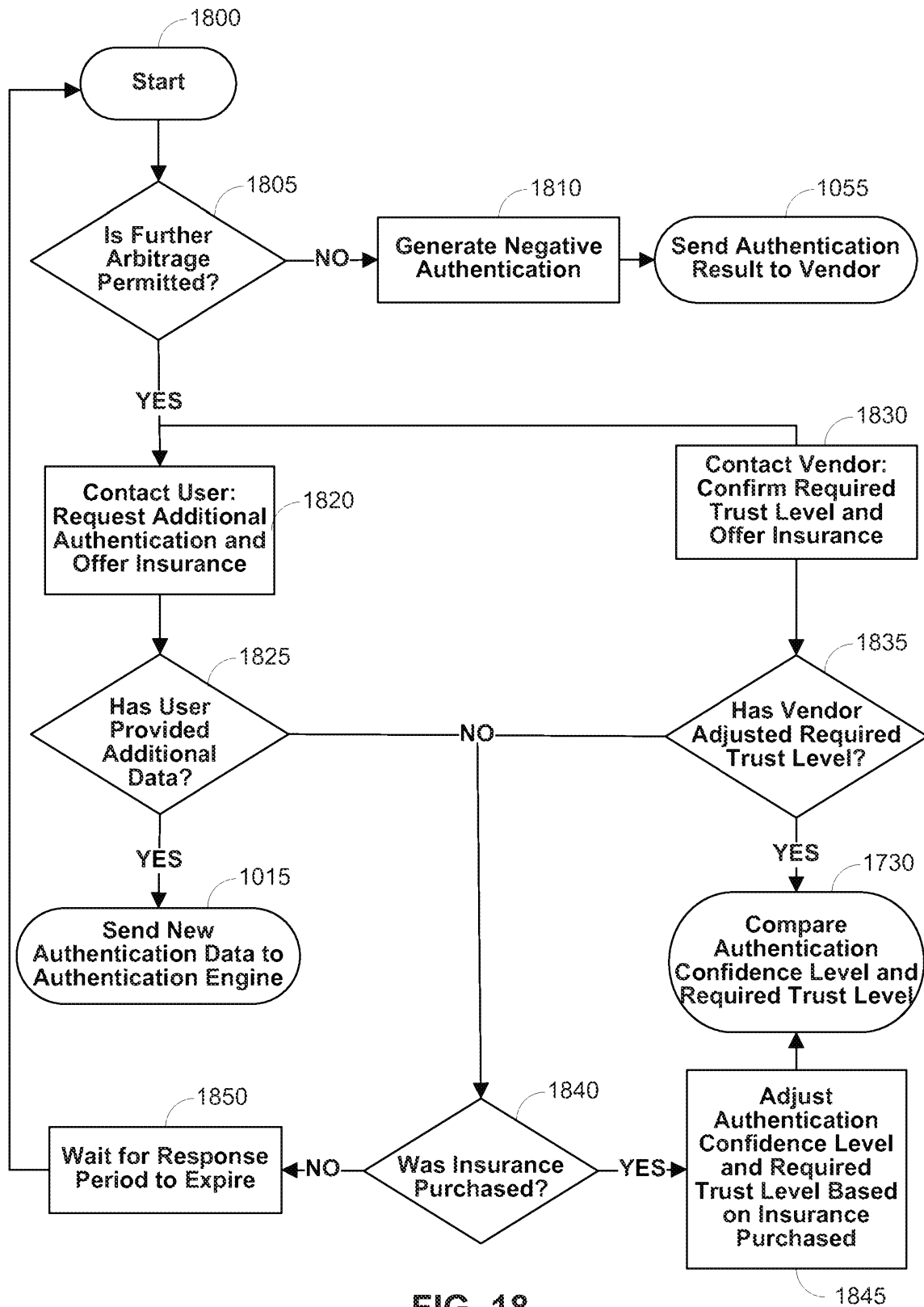

FIG. 18

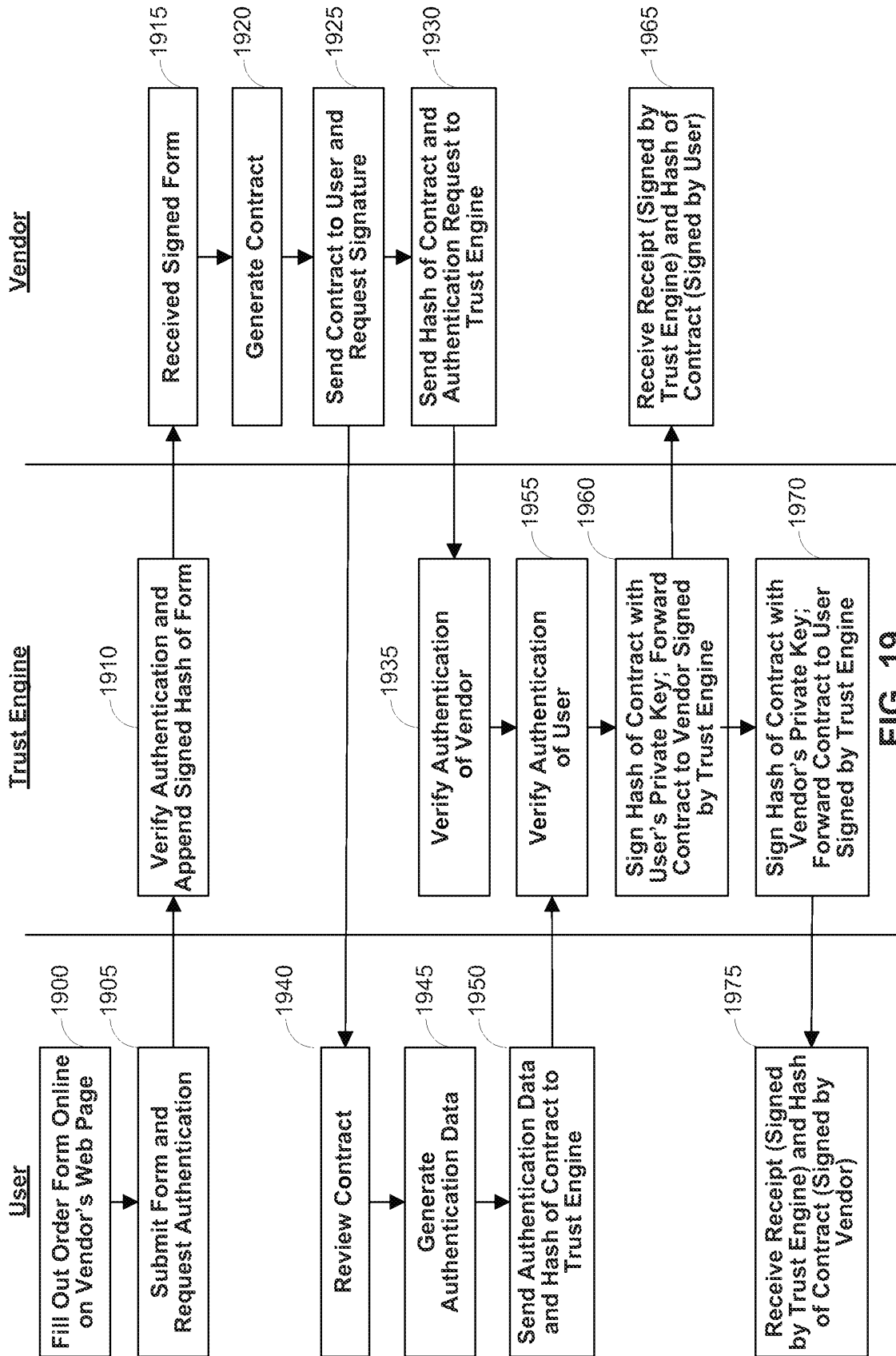

FIG. 19

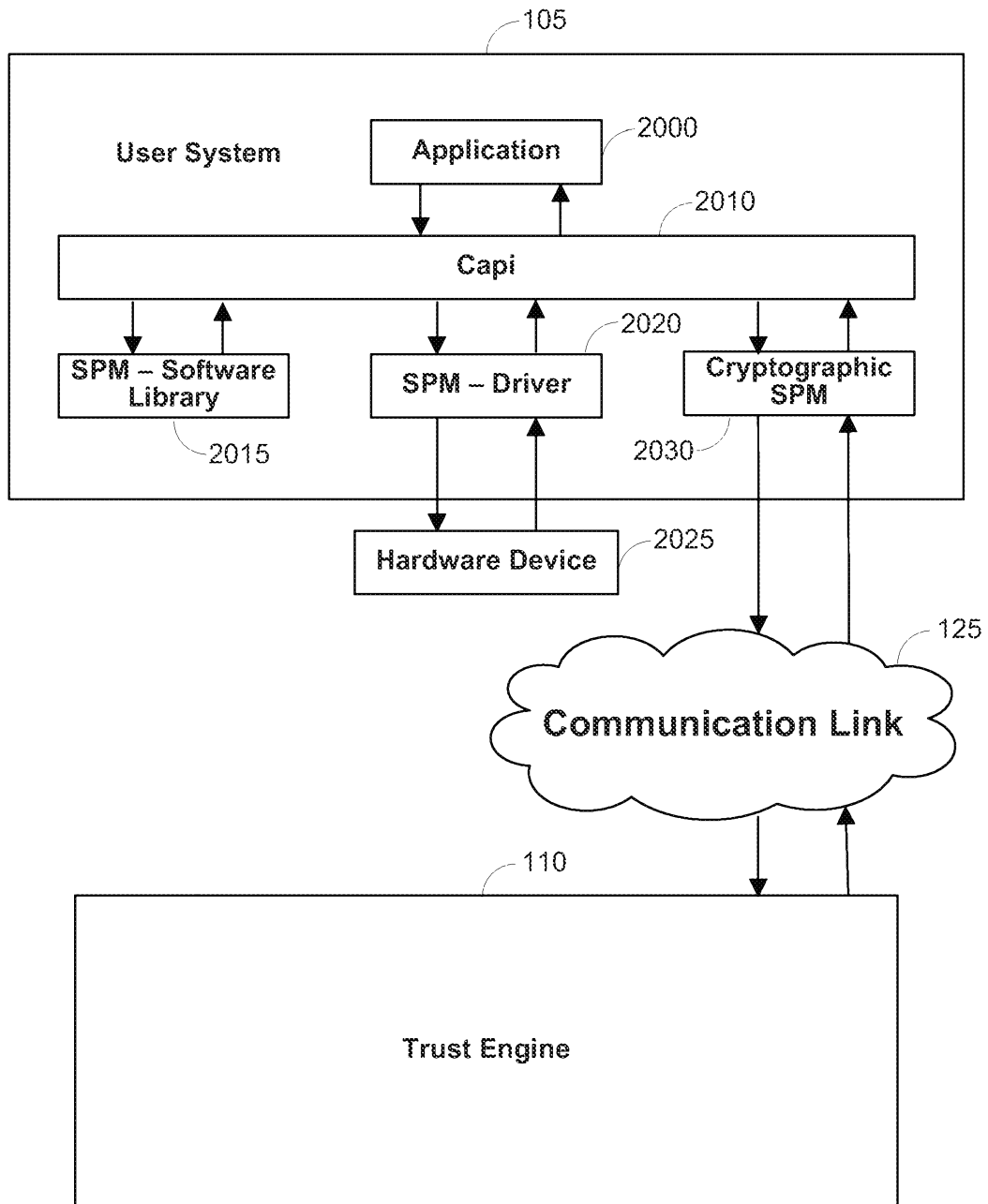

FIG. 20

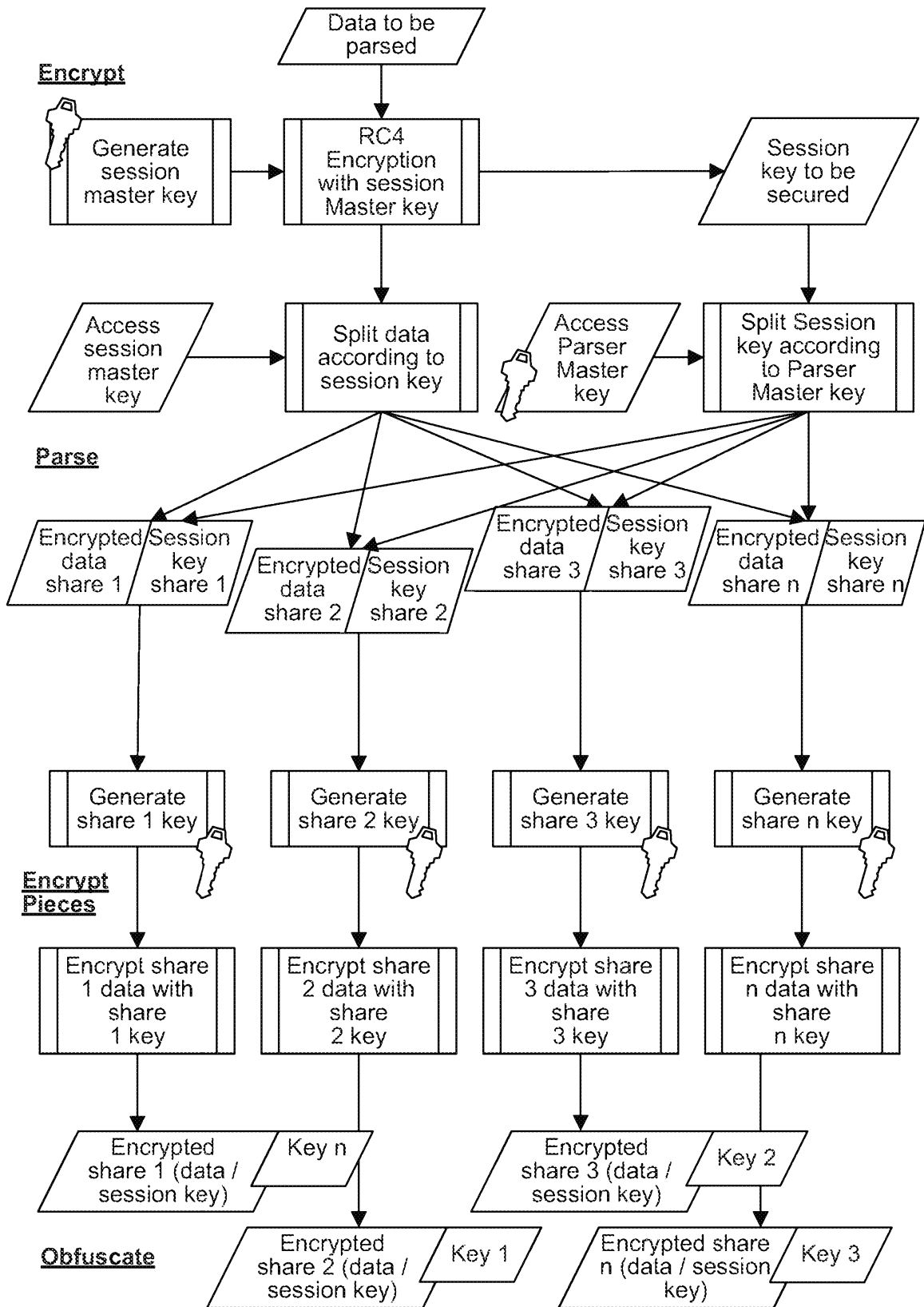

FIG. 21

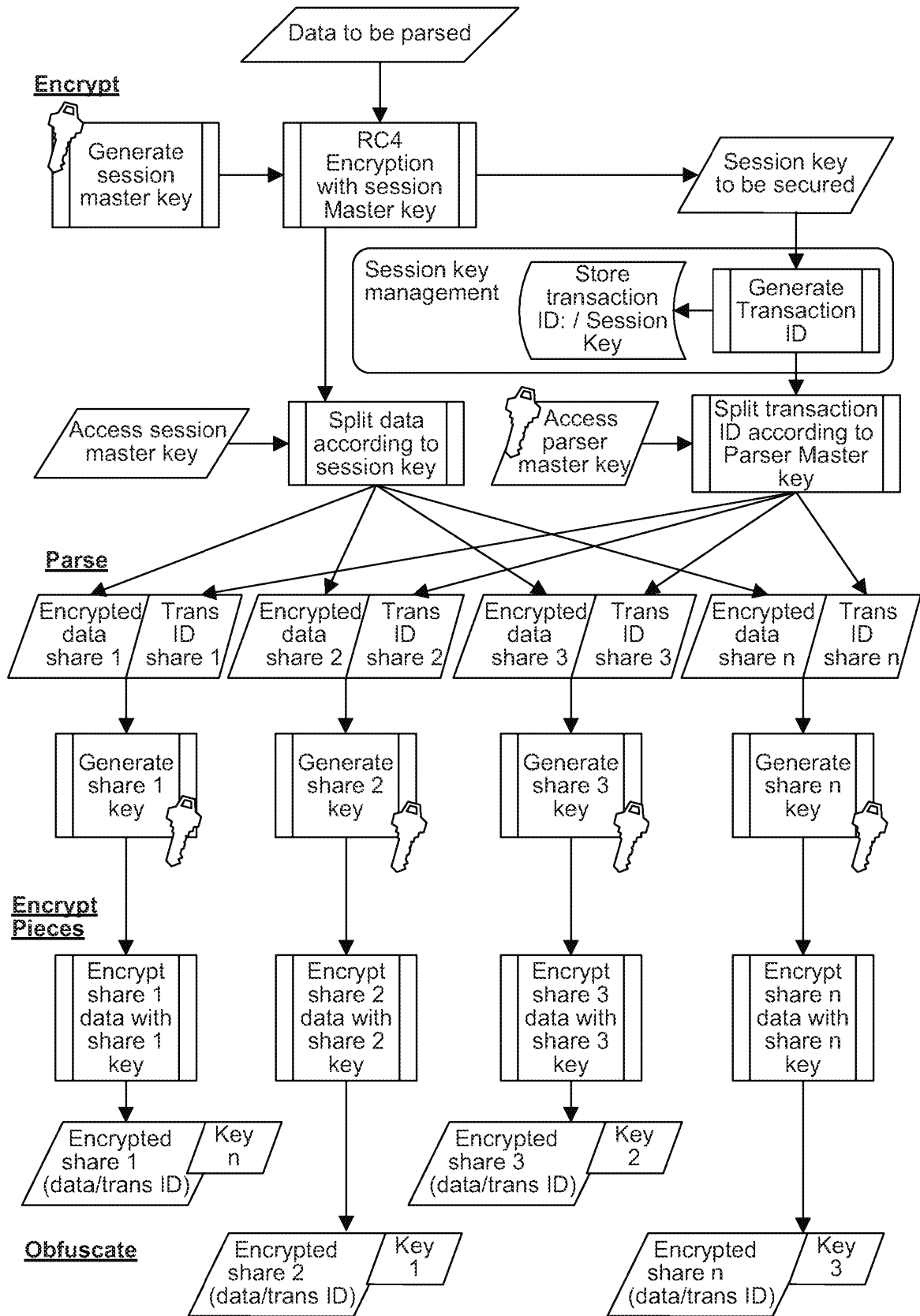

FIG. 22

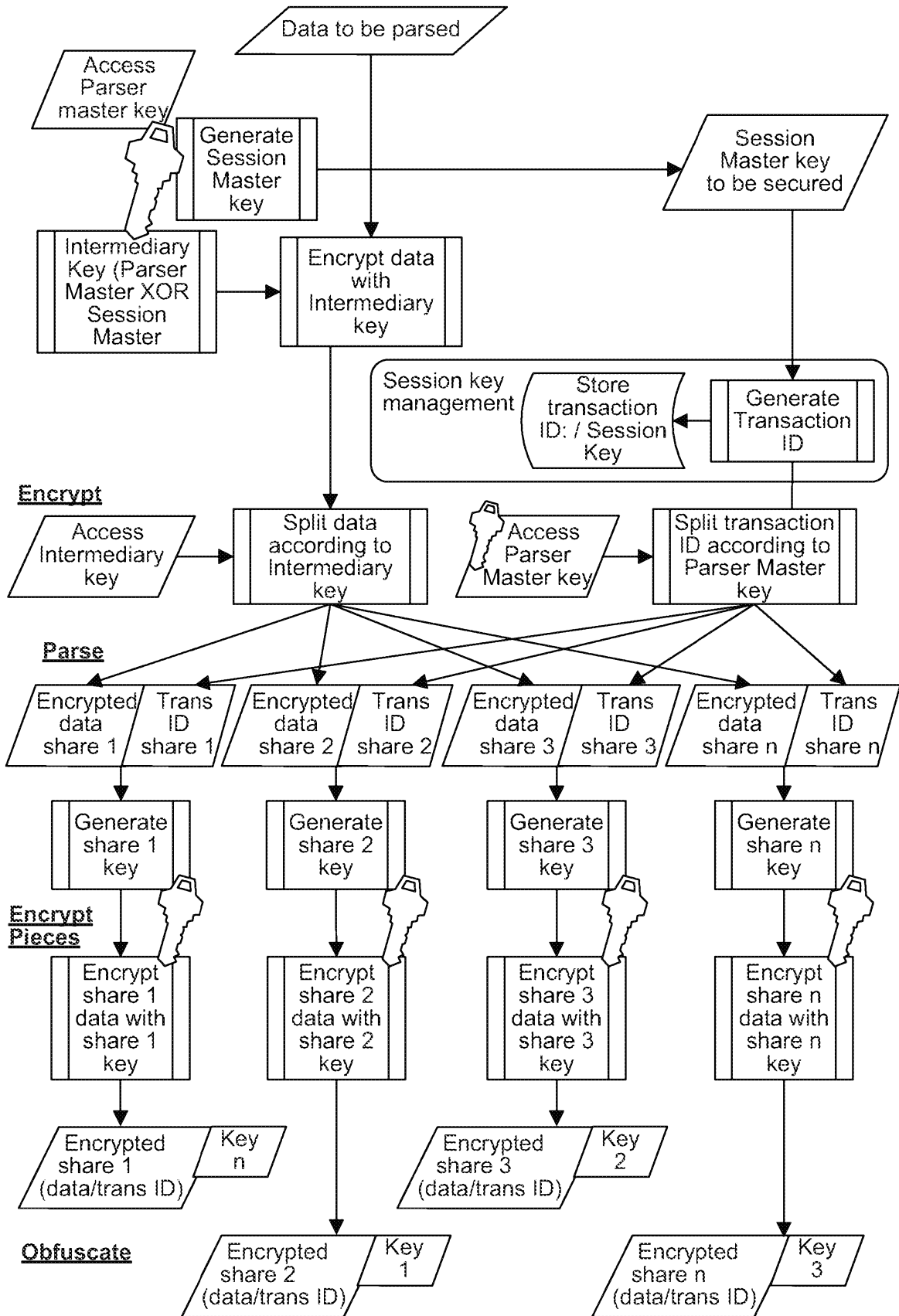

FIG. 23

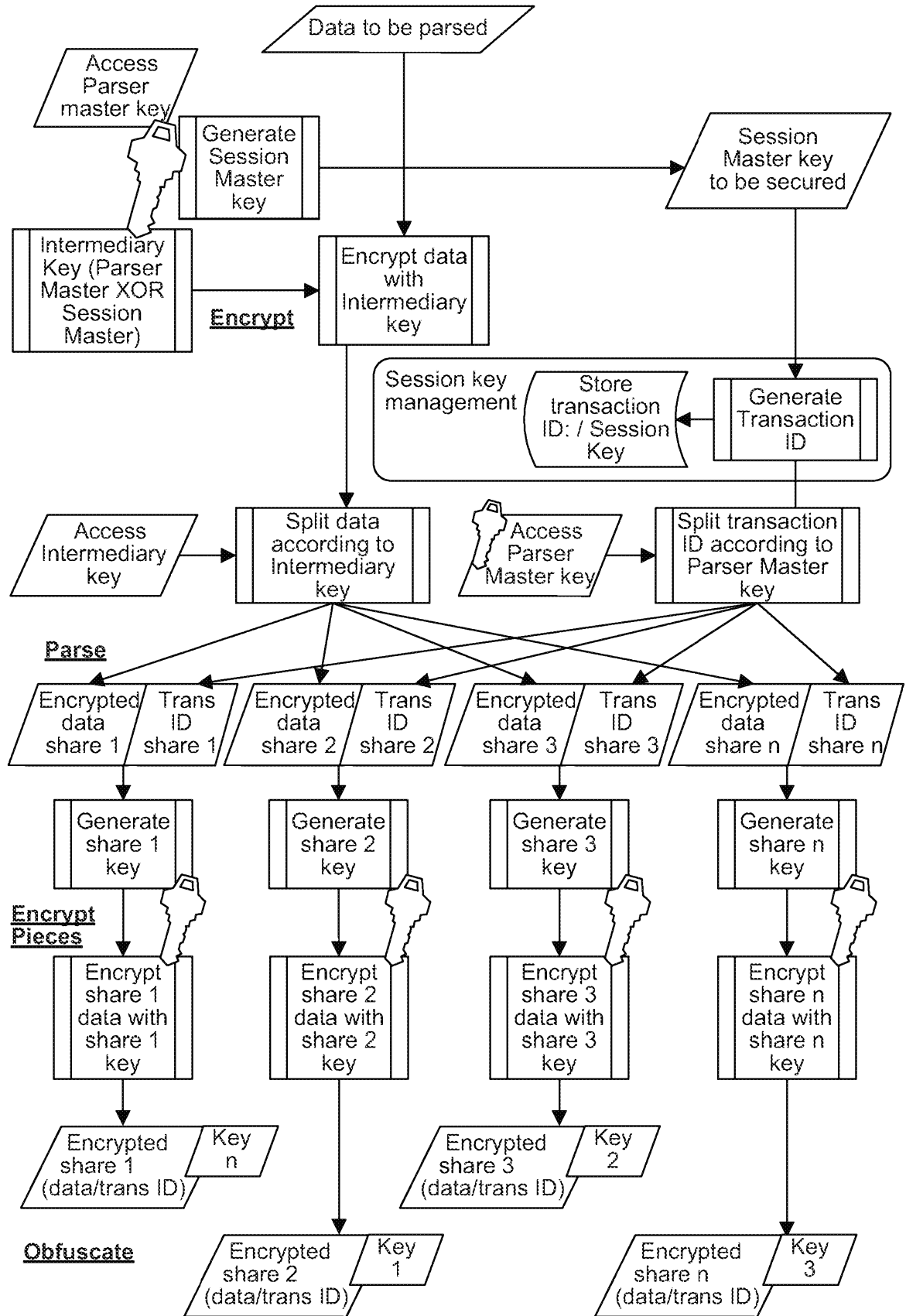

FIG. 24

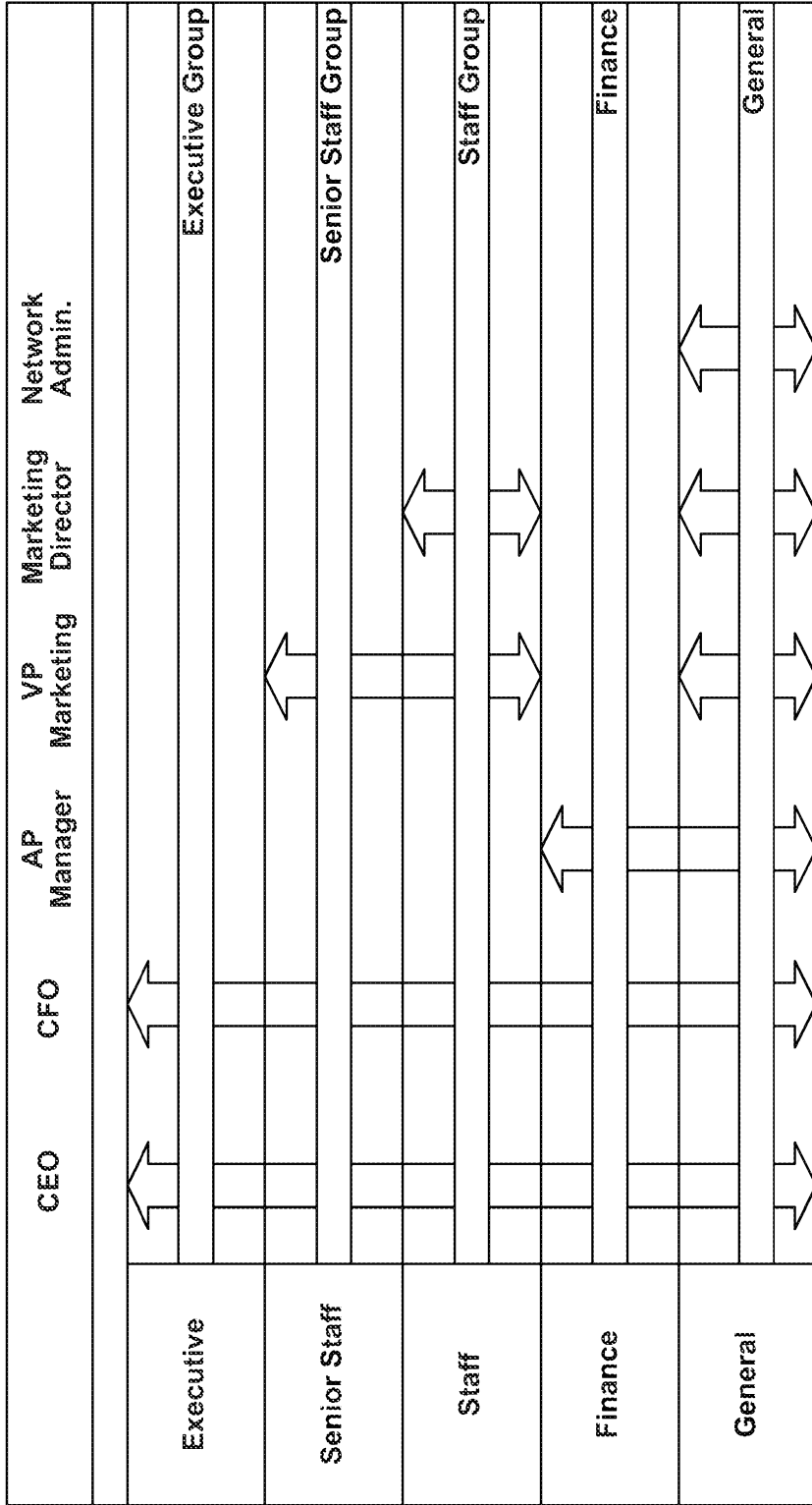

FIG. 25

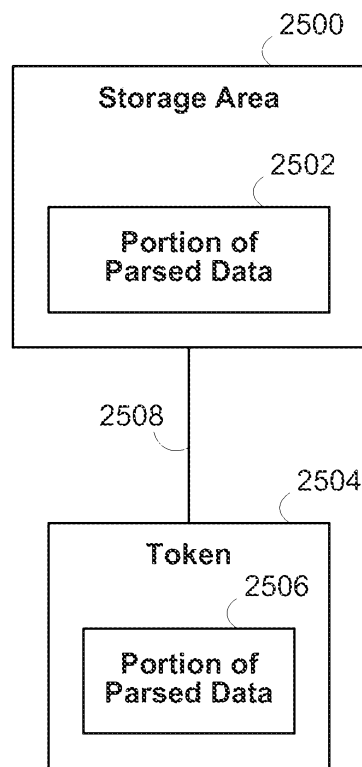

FIG. 26

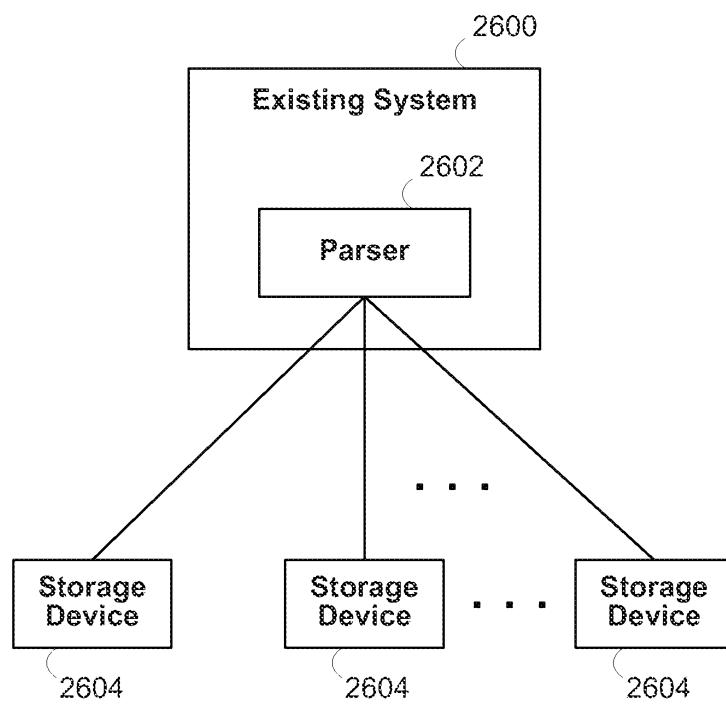

FIG. 27

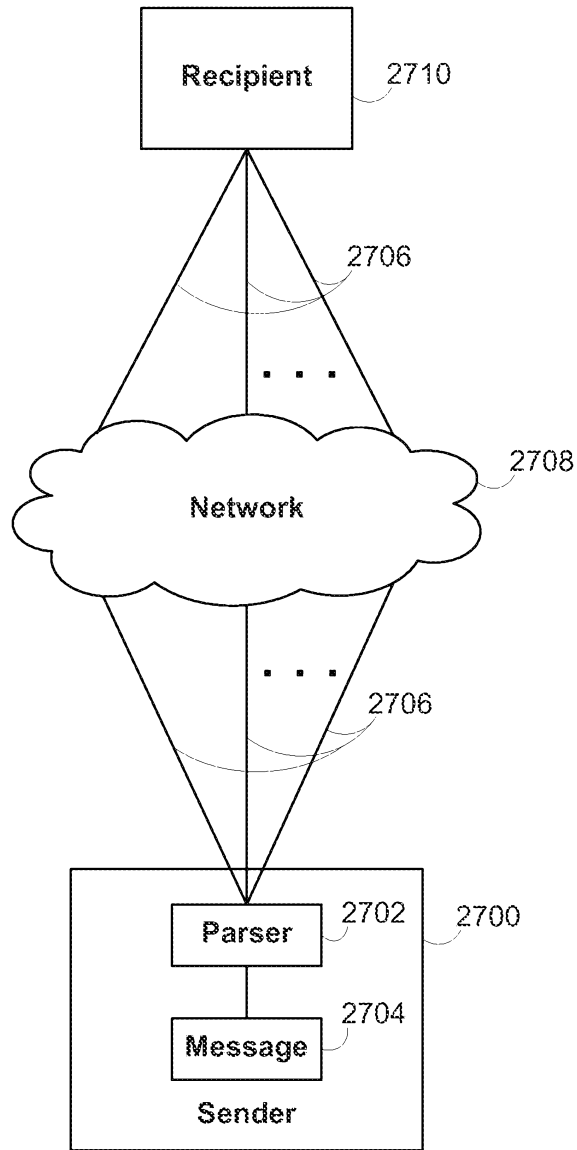

FIG. 28

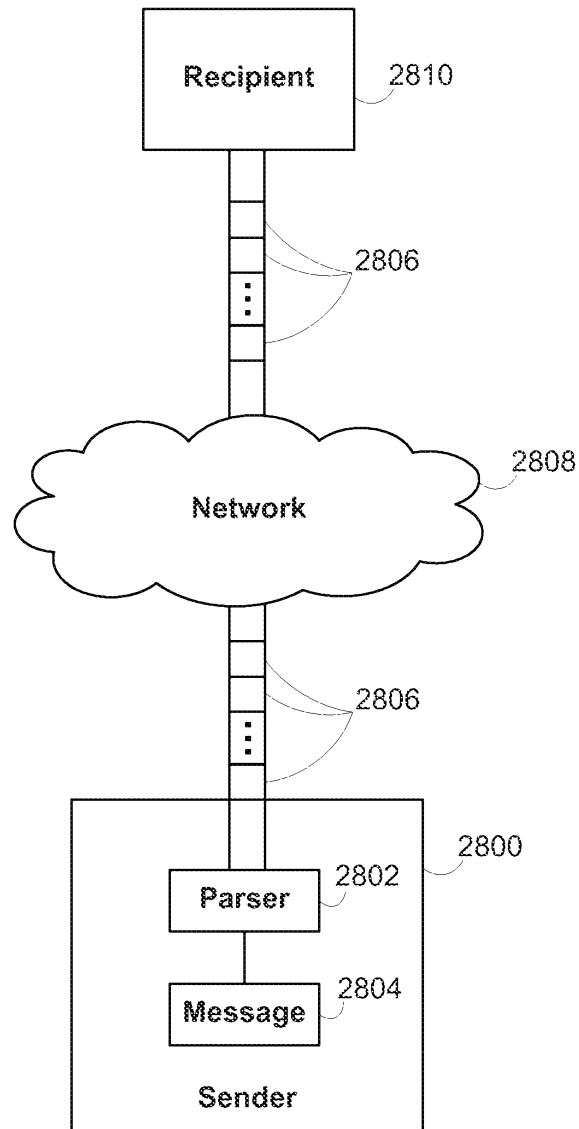

FIG. 29

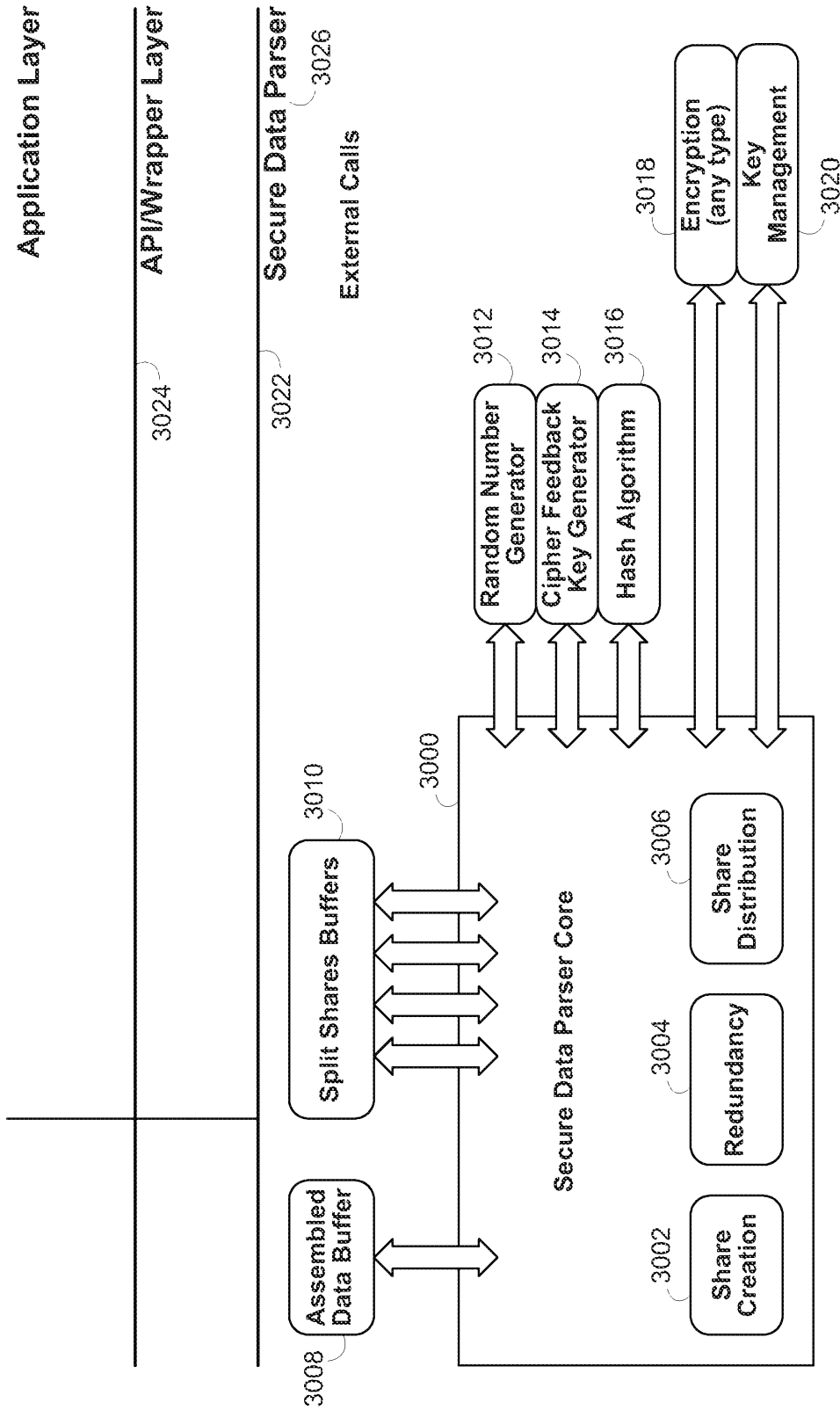

FIG. 30

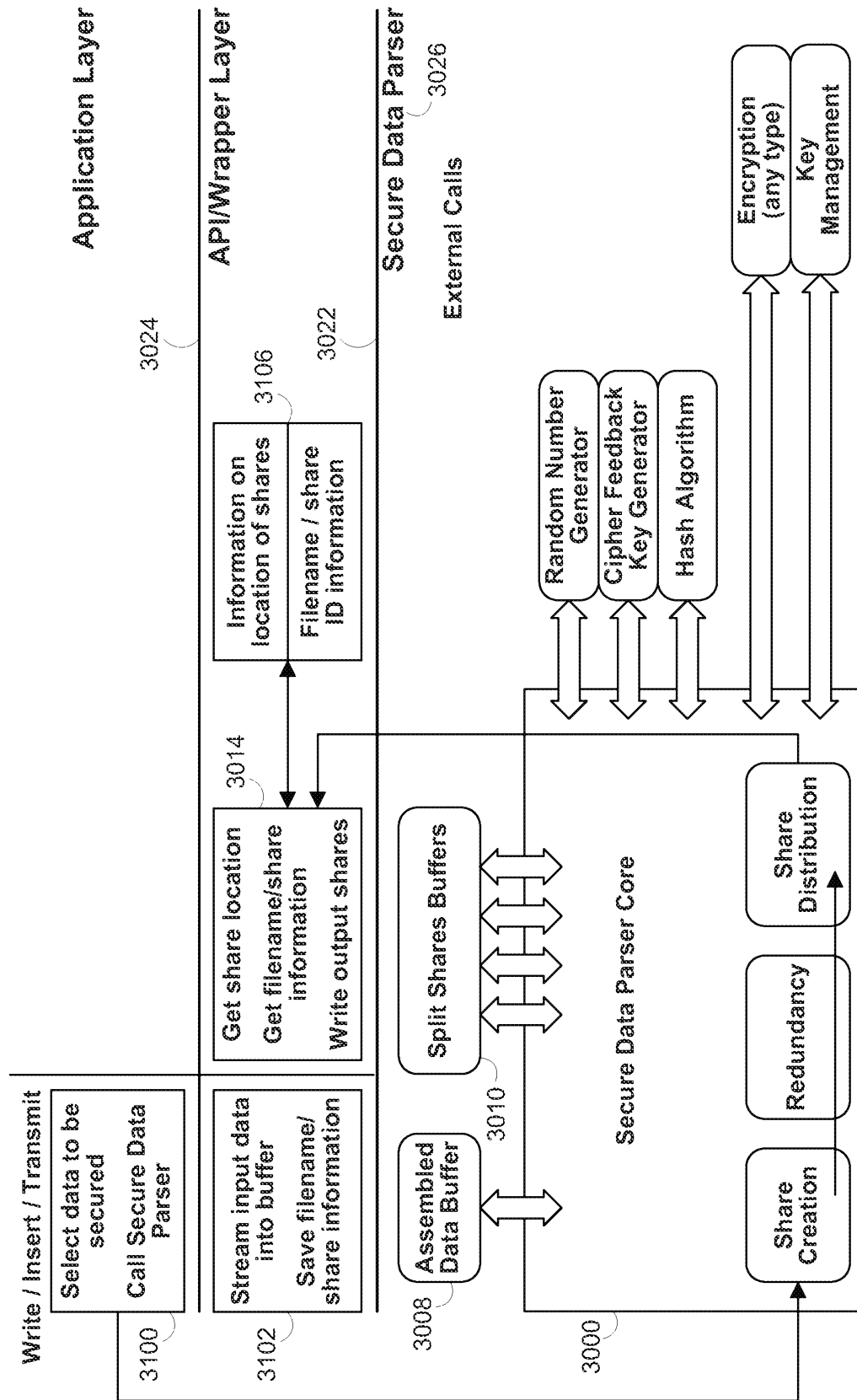

FIG. 31

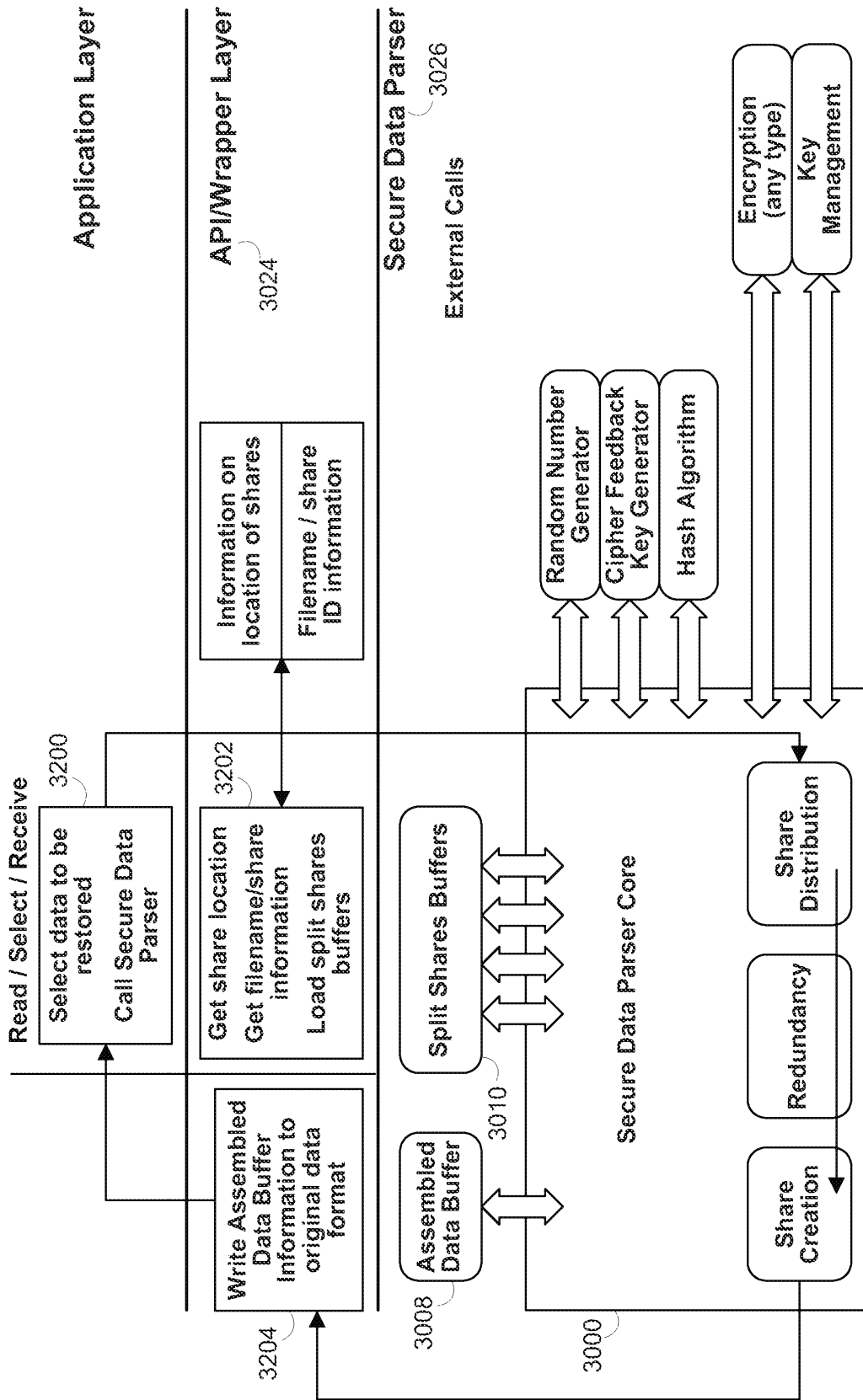

FIG. 32

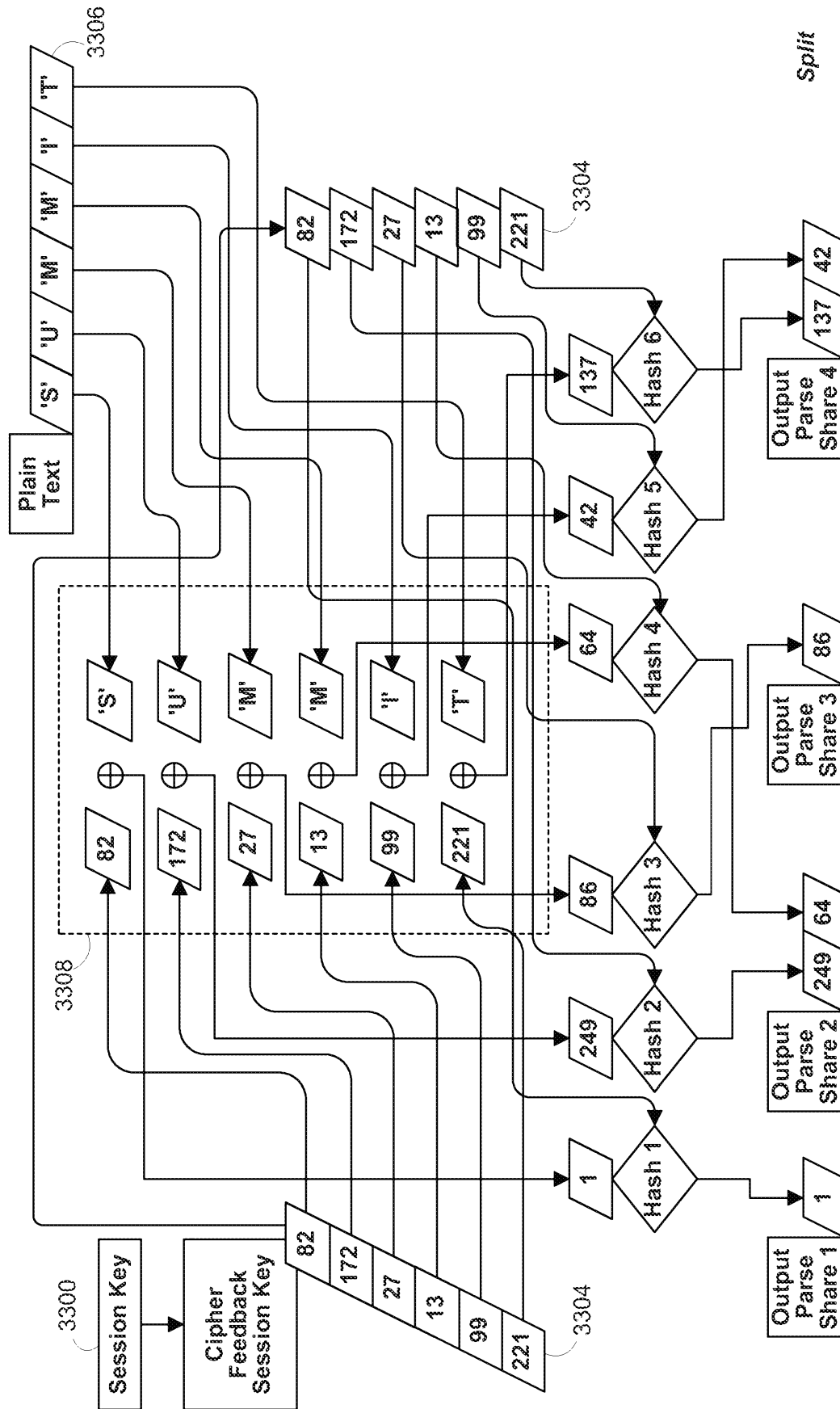

FIG. 33

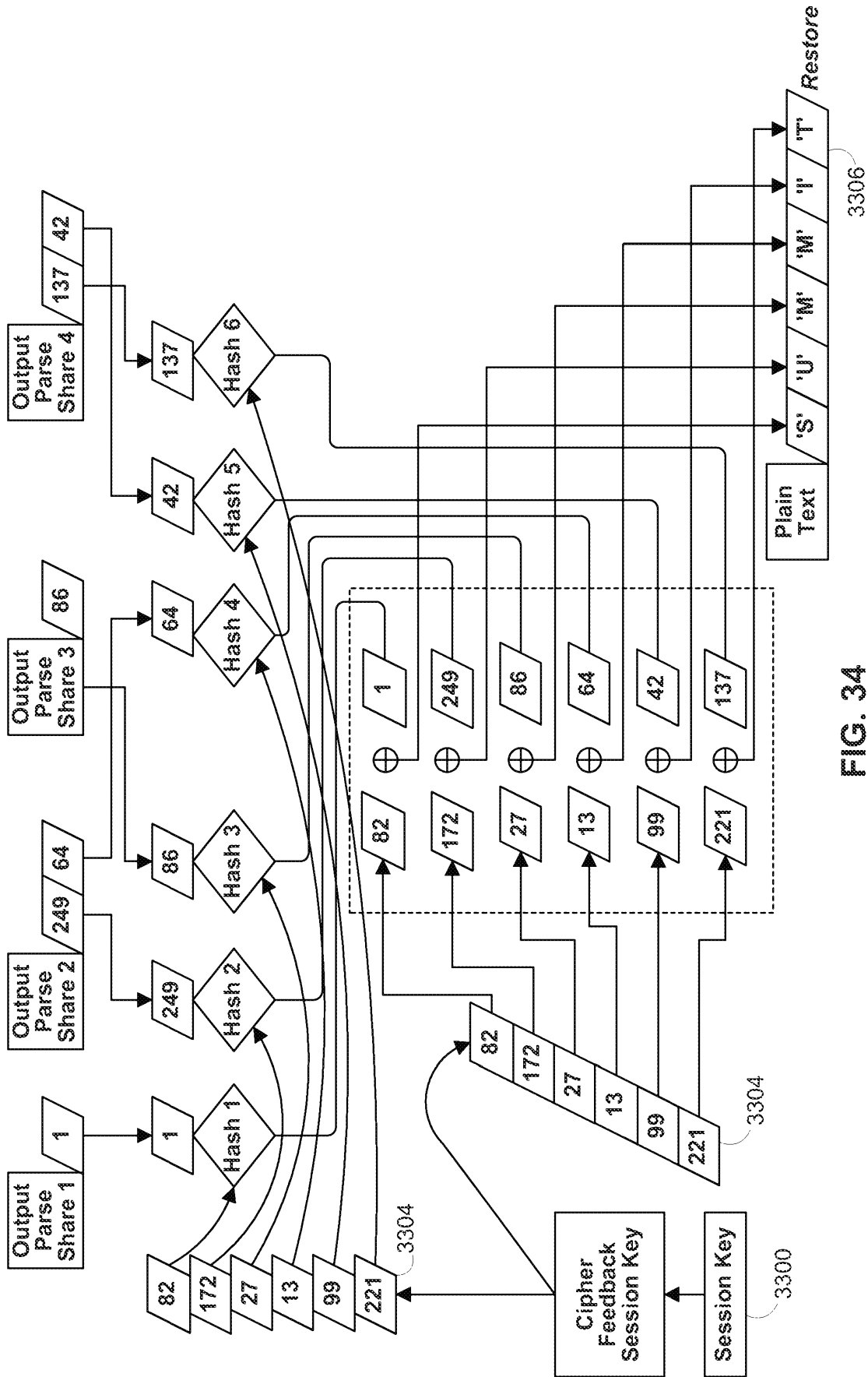

FIG. 34

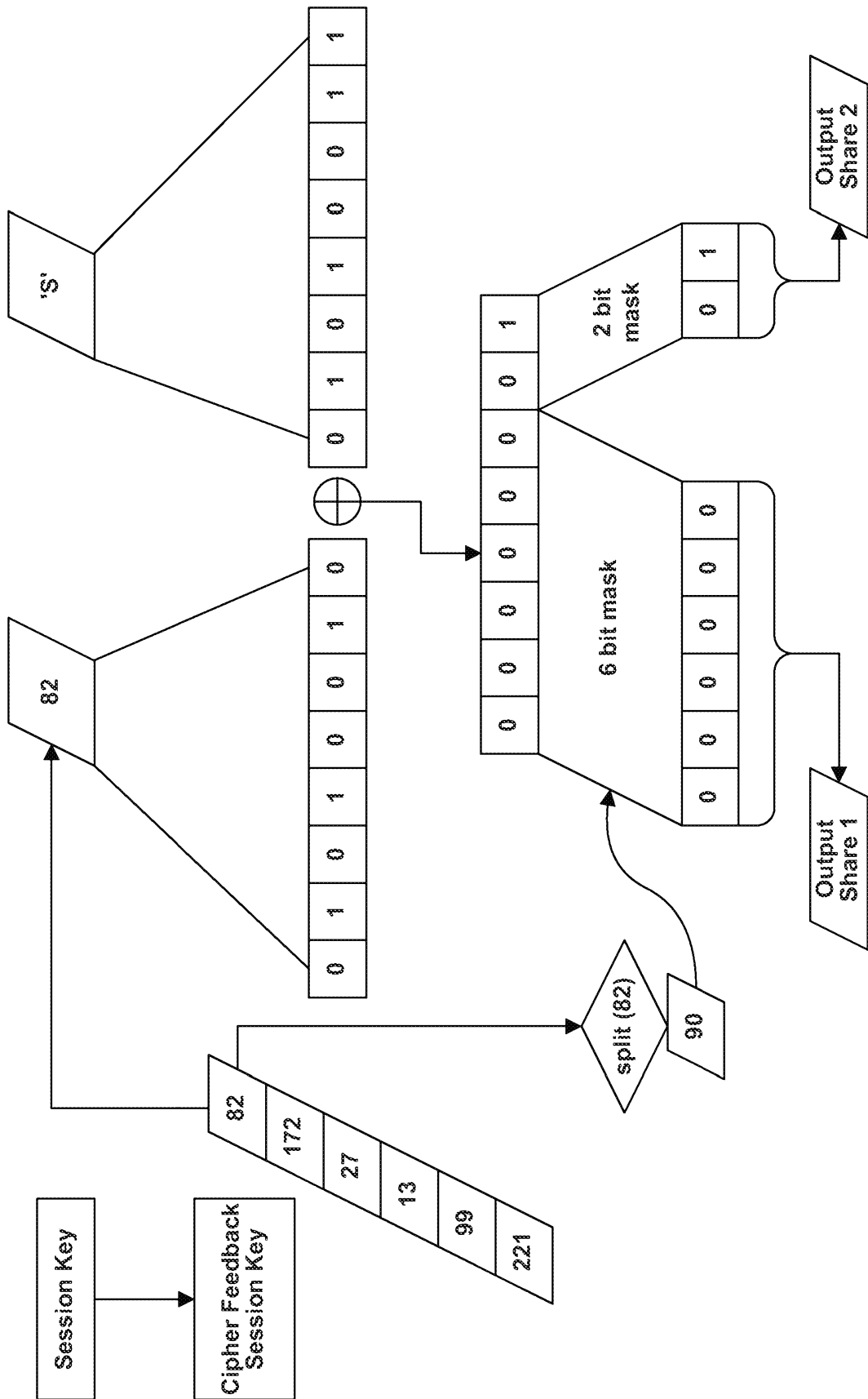

FIG. 35

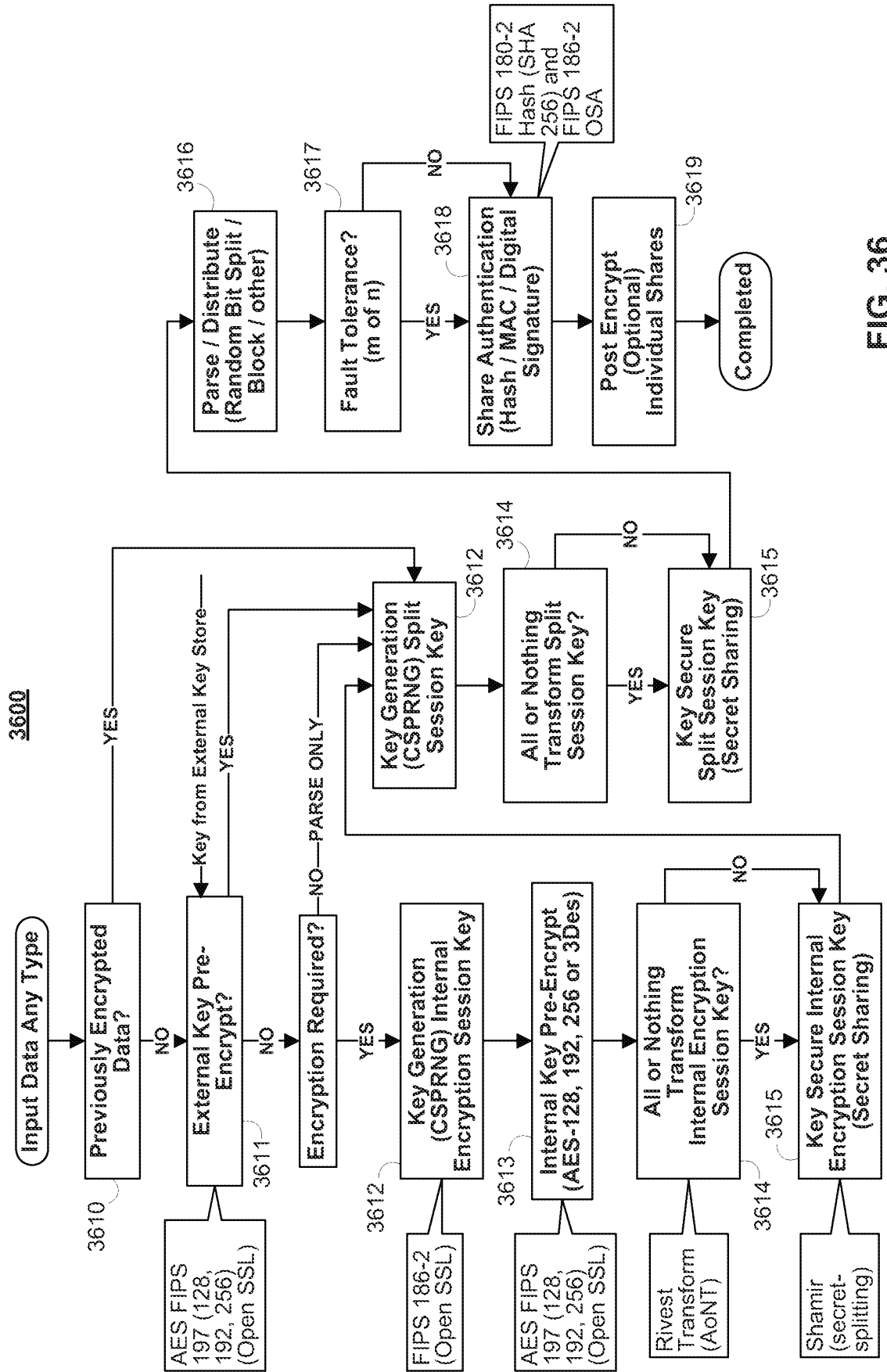

FIG. 36

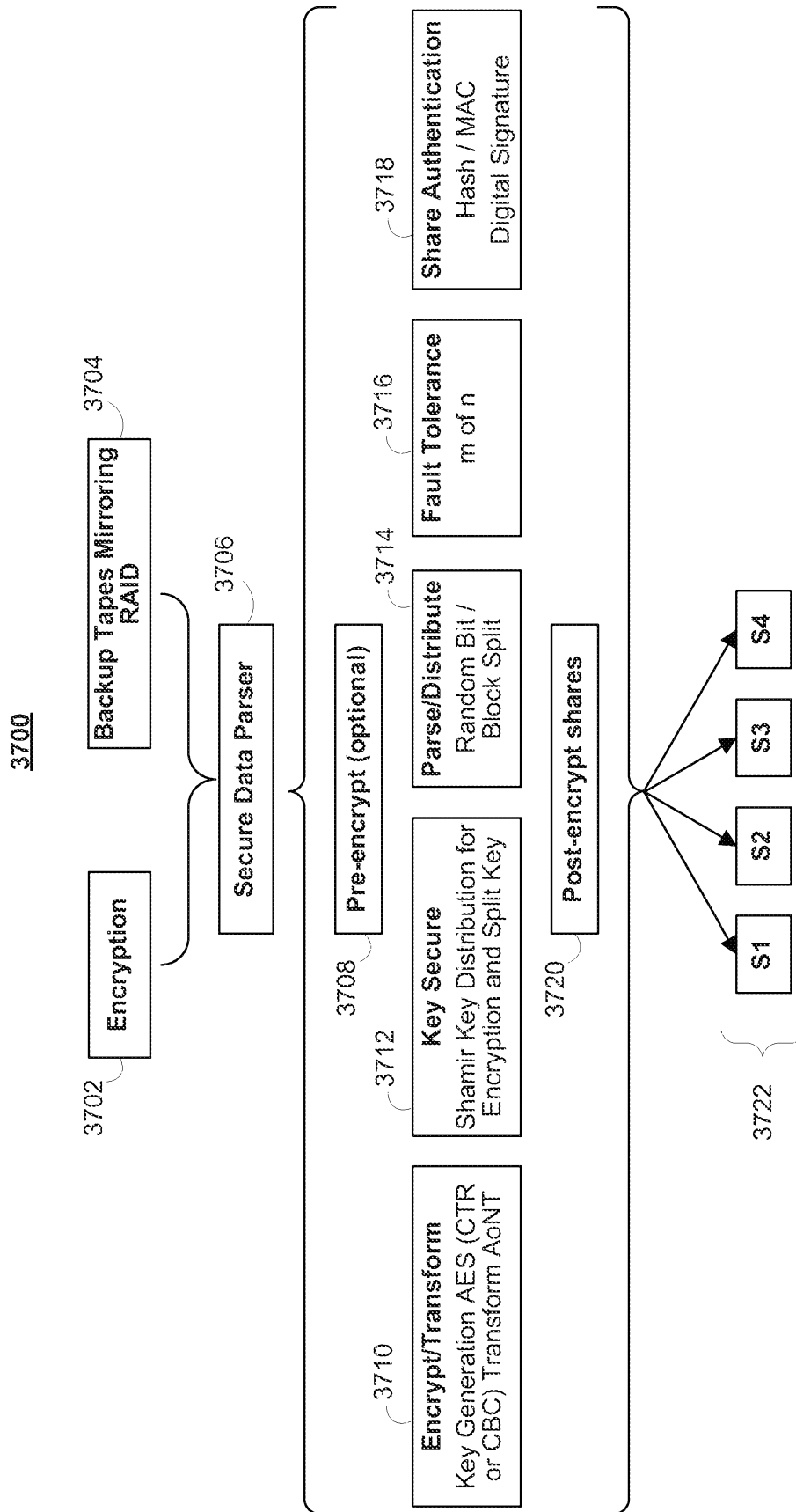

FIG. 37

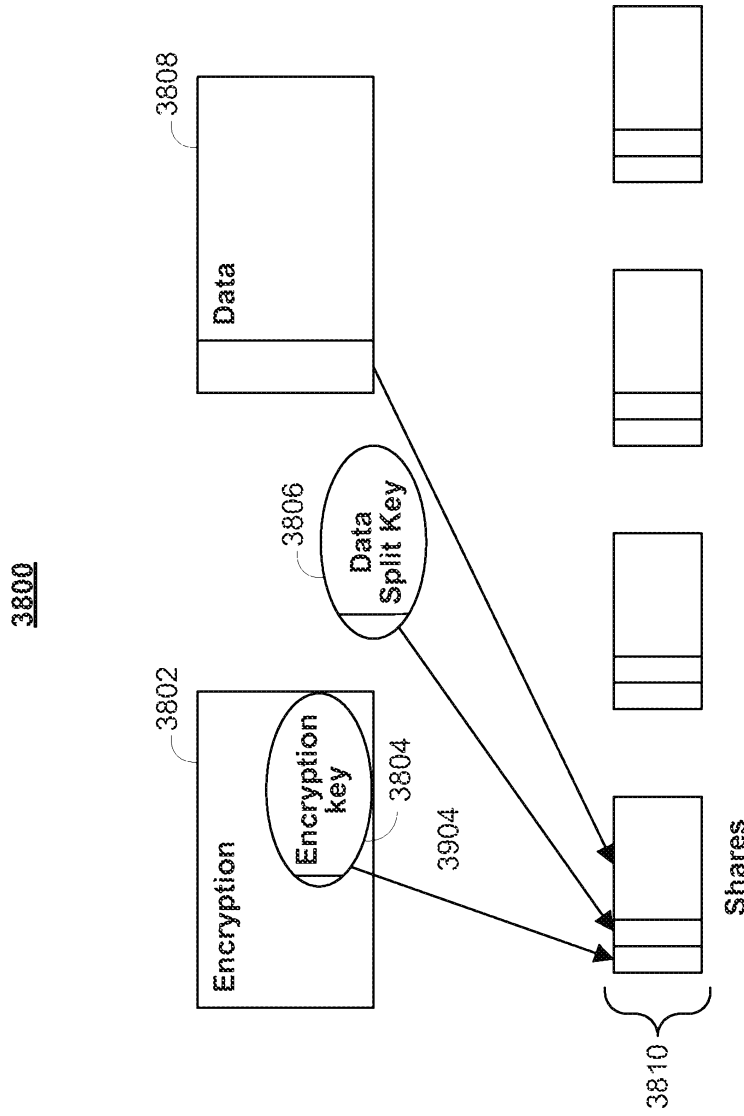

FIG. 38

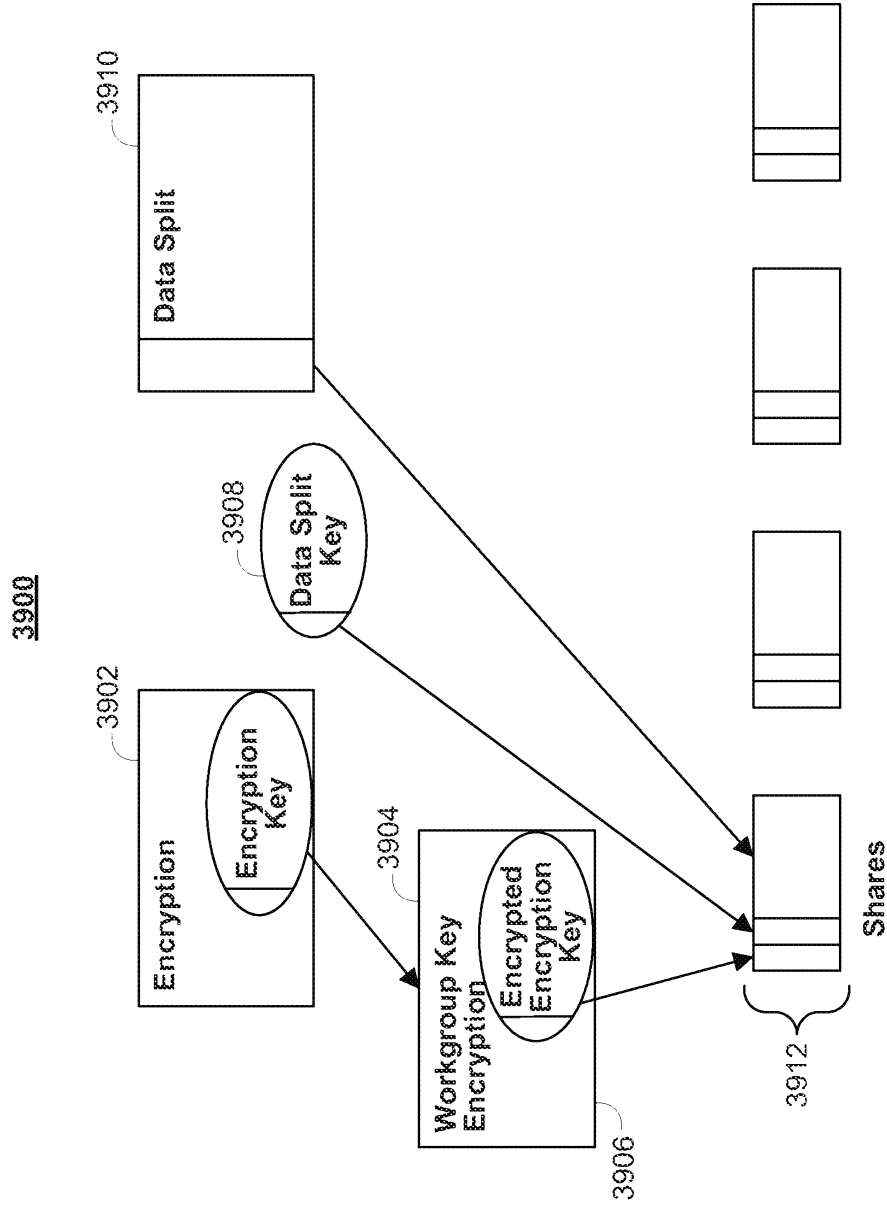

FIG. 39

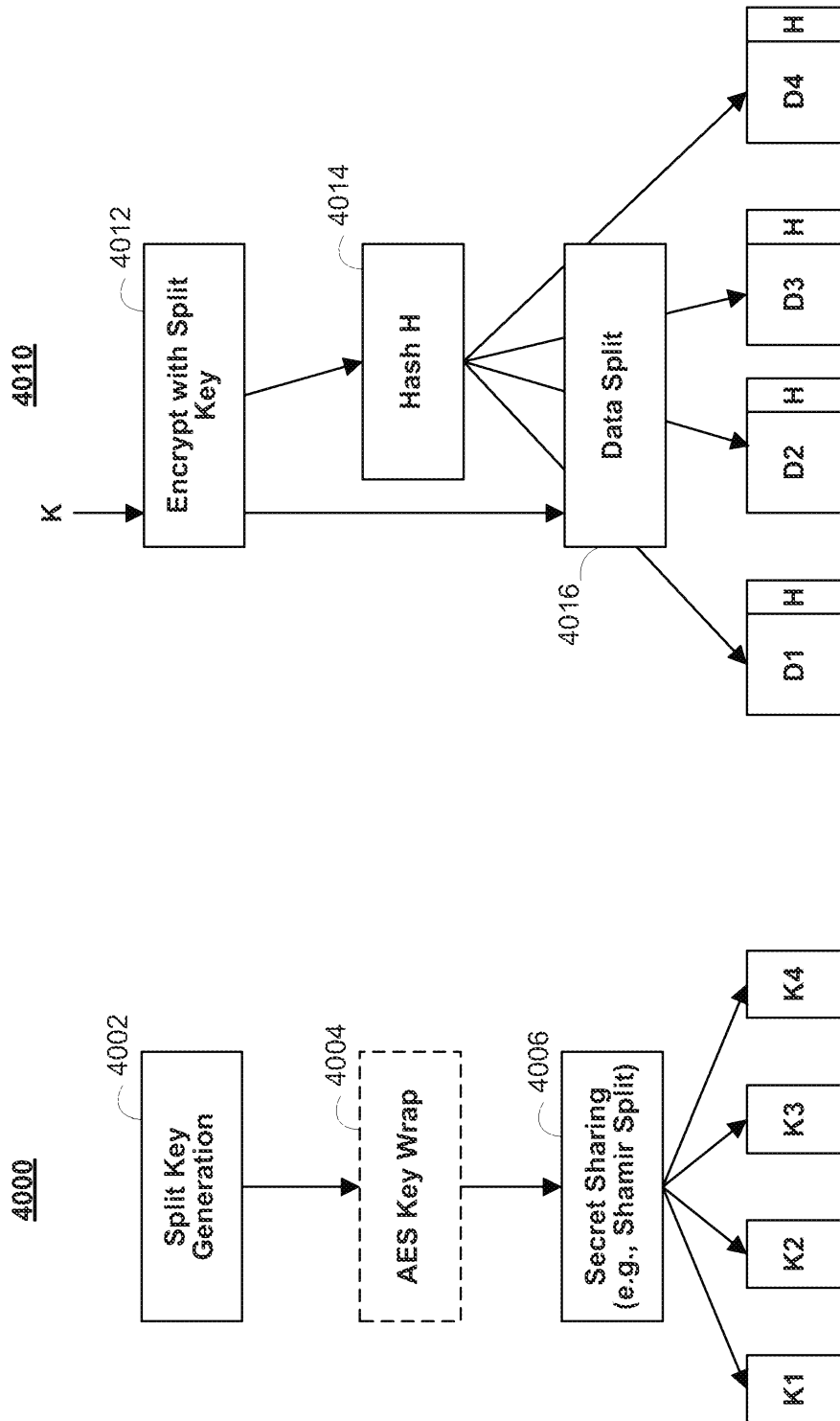

FIG. 40A

FIG. 40B

4100

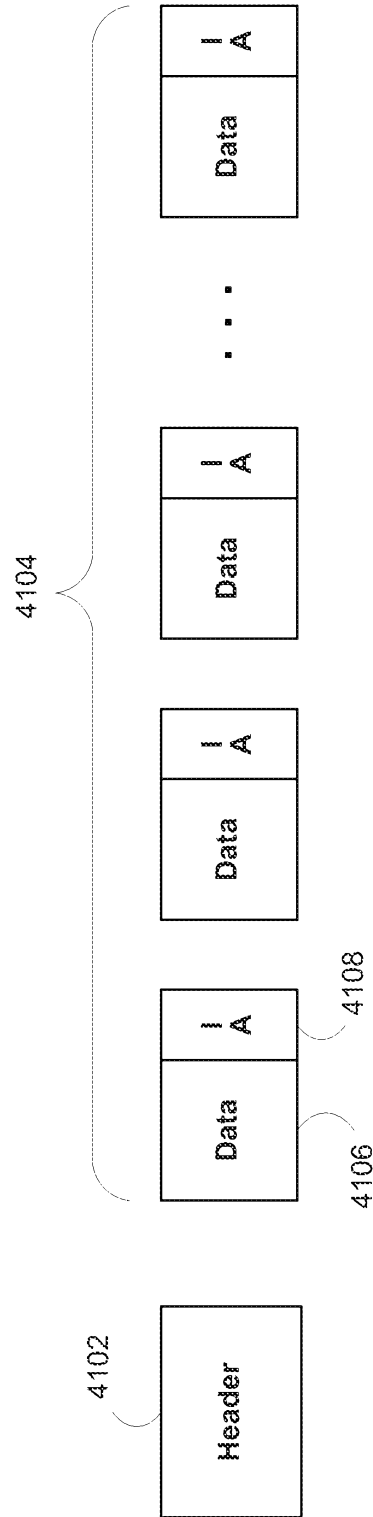

FIG. 41

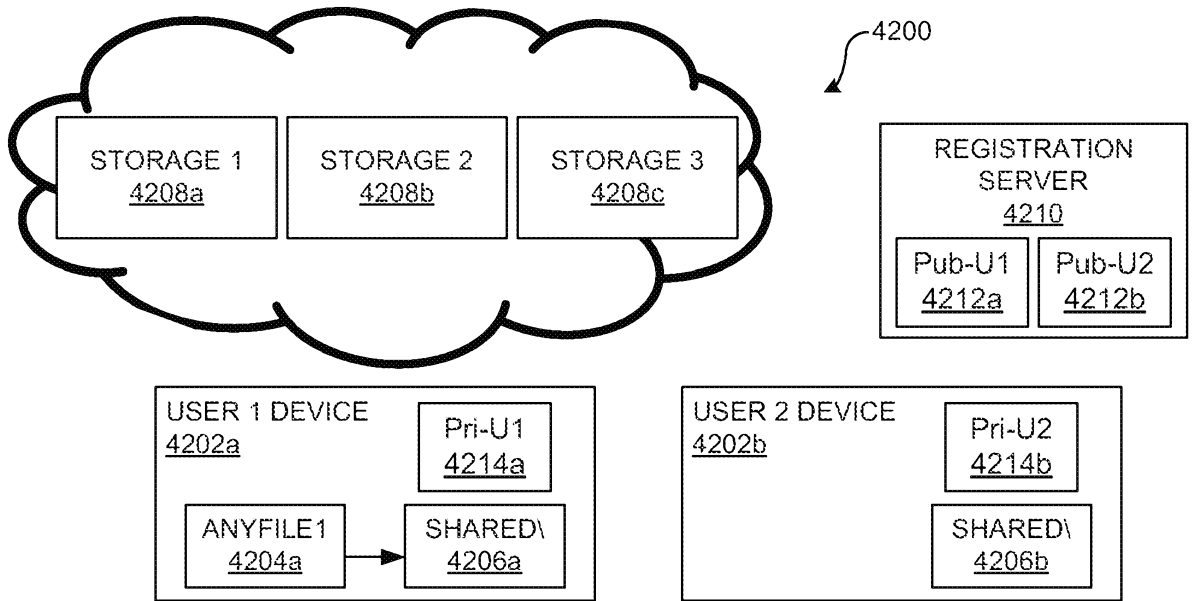

FIGURE 42A

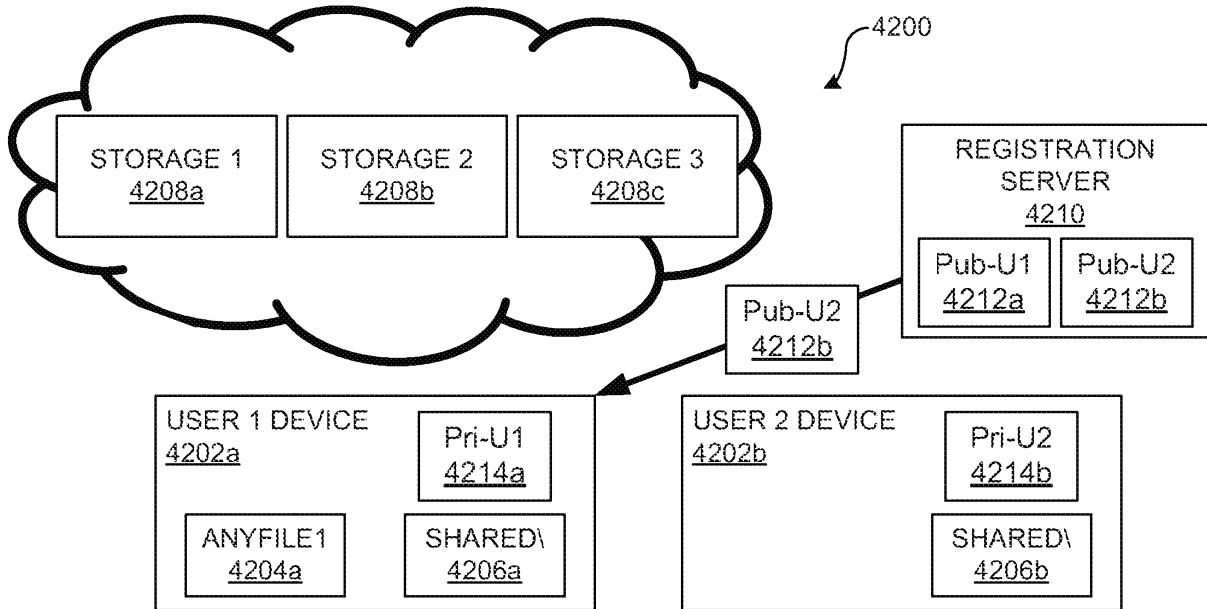

FIGURE 42B

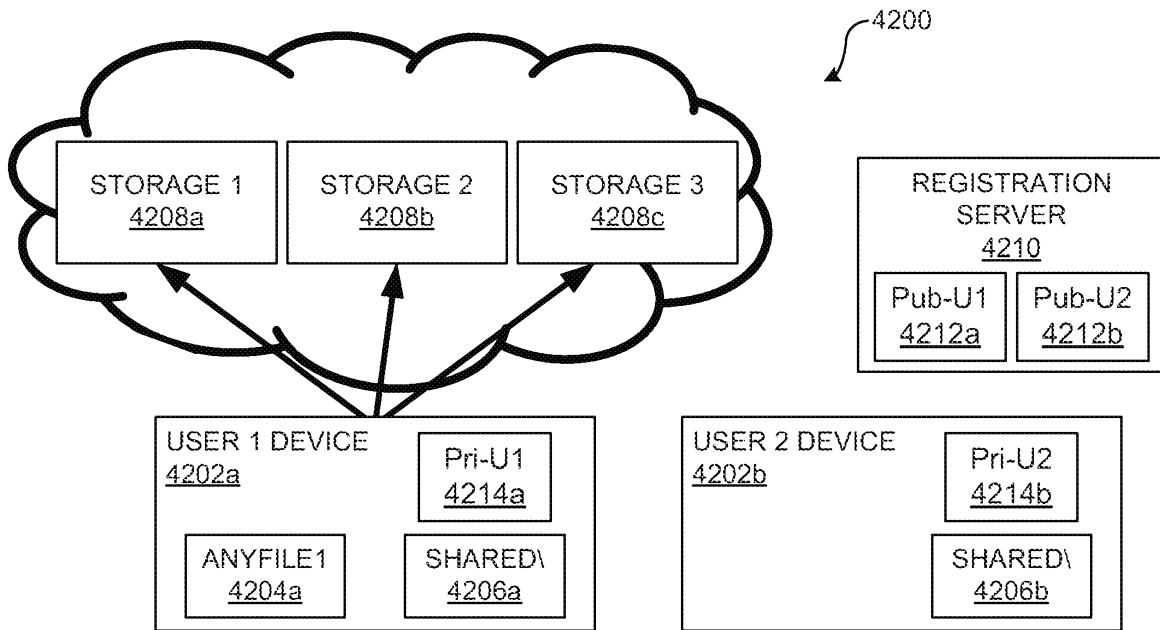

FIGURE 42C

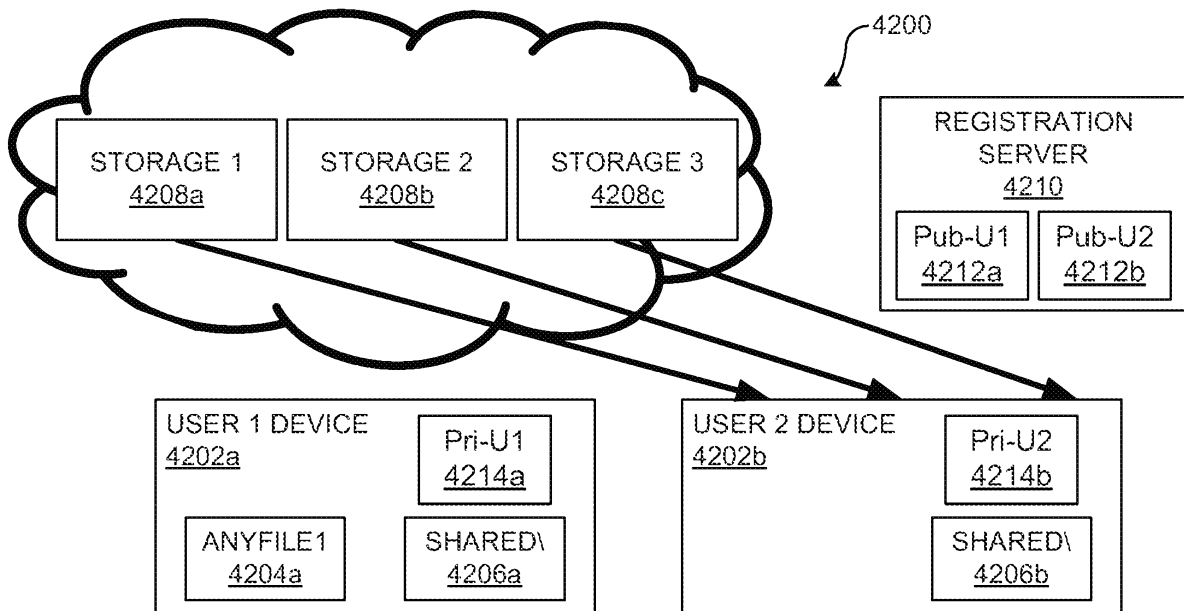

FIGURE 42D

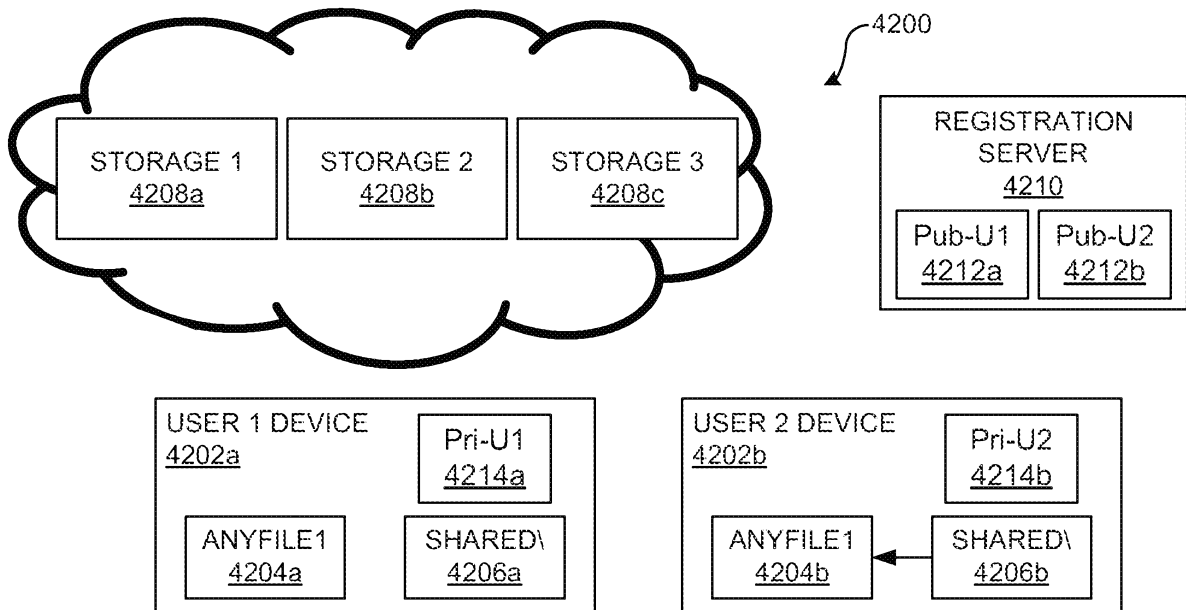

FIGURE 42E

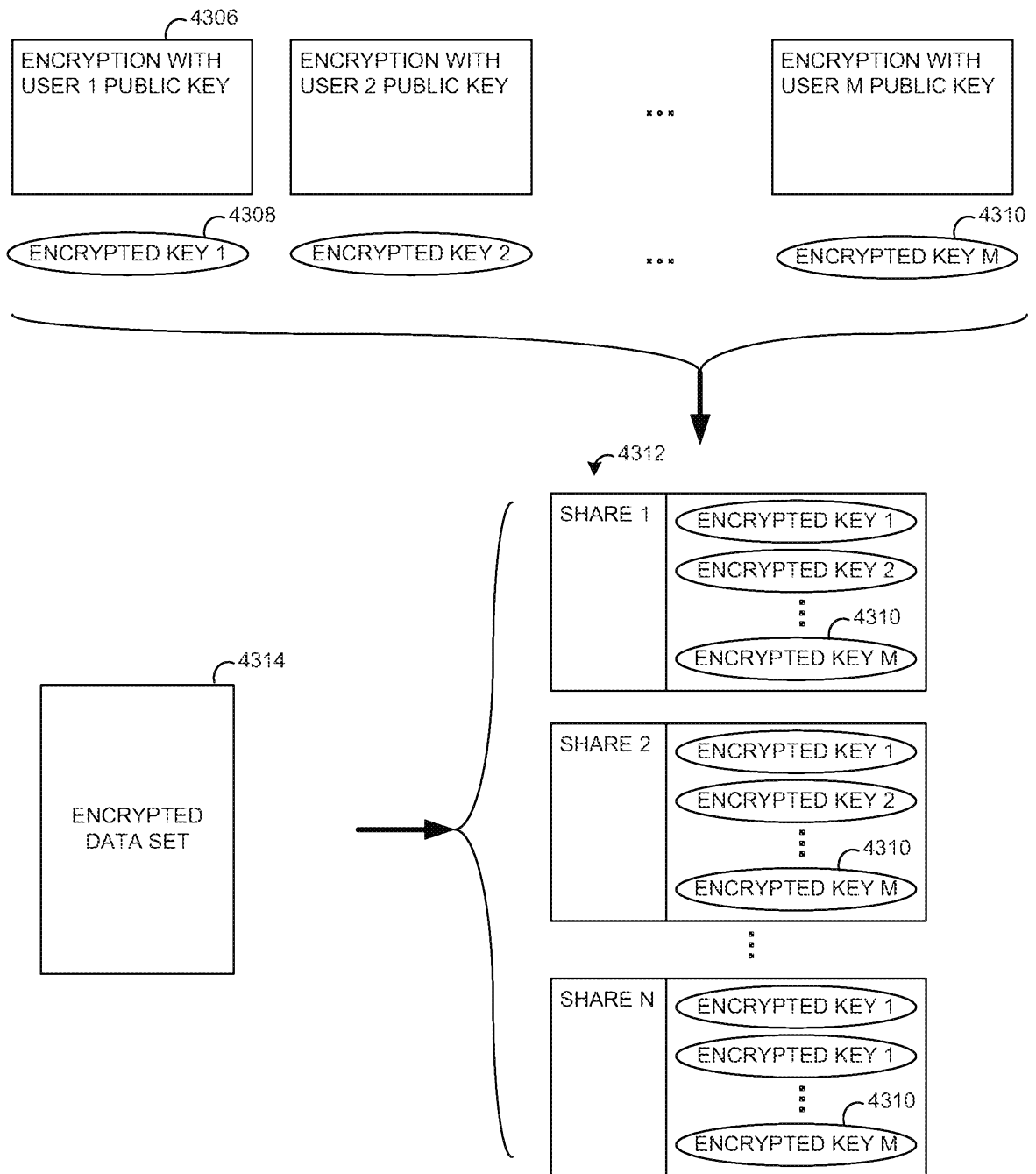

FIGURE 43

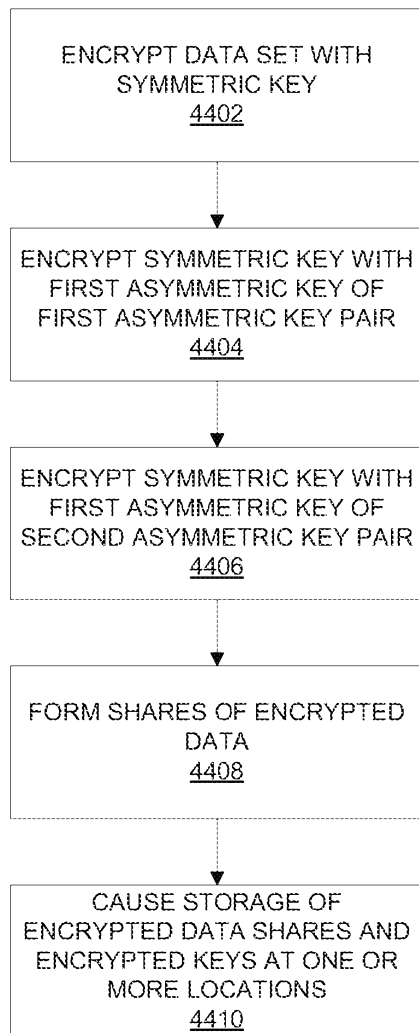

FIGURE 44

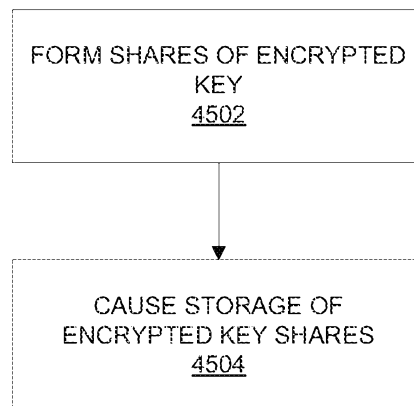

FIGURE 45

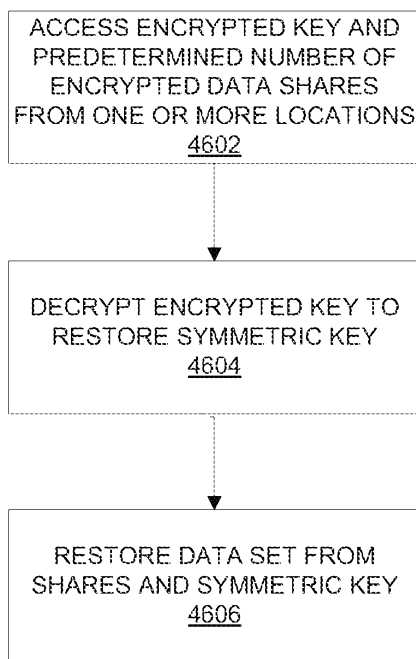

FIGURE 46

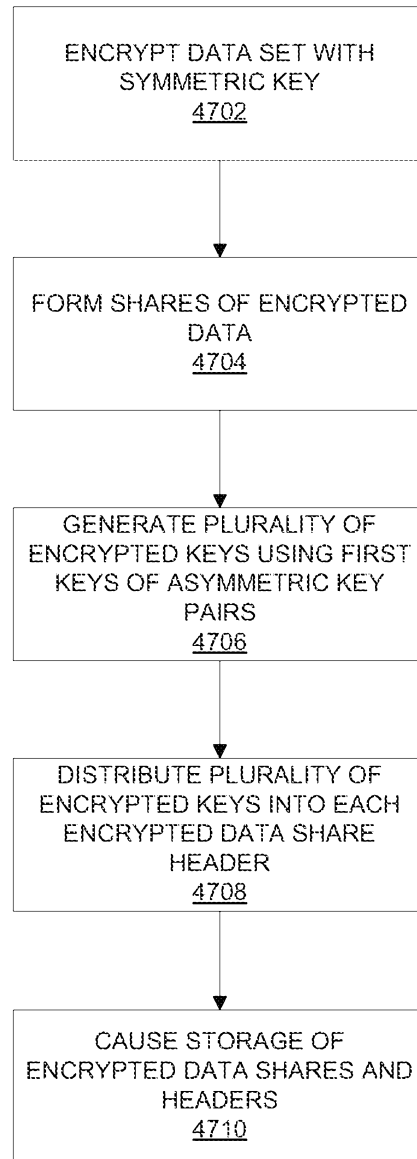

FIGURE 47