

(19)
(12)

(KR)
(B1)

(51) 。 Int. Cl. ⁶
G09G 3/28

(45)
(11)
(24)

2002 10 30
10 - 0358697
2002 10 15

(21) 10 - 1999 - 0036732
(22) 1999 08 31

(65) 2001 - 0020047
(43) 2001 03 15

(73)

20 LG

(72)

2 1325 102

(74)

:

(54)

/ 가 1 ; / 가
/ 가 2 .
,

1 PDP 3 PDP .

2 PDP .

3 PDP .

4a 4b .

5 PDP 3 PDP .

6 5 .

<

10 : 12 :

14 : 16 :

X : Y : /

Z :

(Plasma Display Panel; , PDP) PDP .

, PDP가 PDP 가

가 가 .

, 8 256 1 (16.67msec) 8 ,

. 1 3 PDP 1 /

(YS, ZS, XS) . 1 PDP /

가 가 .

/ 가 가 가

. , / 가

가

가

가

가

1:2:4:8:....:128

가

가

2

(10)

(Y)

(Z)

(12)

X)

(16)

(10)

)

PDP

가

(14)

2

(

(X) 가

가

가

가

가

가

, PDP

가

(Writing)

3

4

(Priming)

(Y)

(Z)

(Contrast)

(Y)

(Z)

가 가

(X)

'0'

가

(X)

가

(Y)

가

가

(

가

가

가

Z)

가

가

PDP

PDP

가

/

/

1

;

/

가

/

/

2

3 9

3 PDP 3
 / (Y) (X)
 / (Y) (Z) (Y) (X)
 4a / (Y) (Z) 4b
 (X) 가
 가 (X) /
 (Y) (X) (Drift), (Diffusion)
 / (Y) (Z) 가 (Cou
 pling)
 가 / (Y) (X)

5 PDP (X) /
 (Y) (Z) (XS, YS, ZS) 6a 6k 5
 (X) 가 / (Y) 가
 6a (X) / (Y) 가 /
 6b 가 (X) 가 /
 (Y) 가 (Y) (Z) 가 6c
 6d (X) 가 / (Y) (Z)
 가 (X) / (Y)
 6e 가 / (Y) 가
 (X) 가 6f 가 (X)
 (X) 가 6g

(X) / (Y) 가
 / (Y) (Z) 가 6h
 6k 6i 6j / (Y) (Z) 가

, PDP
 PDP 가
 가

(57)

1.

,
 /
 ' 가 /
 1 ; /
 / 가
 / /
 2 /

2.

1 ,
 2 / /

3.

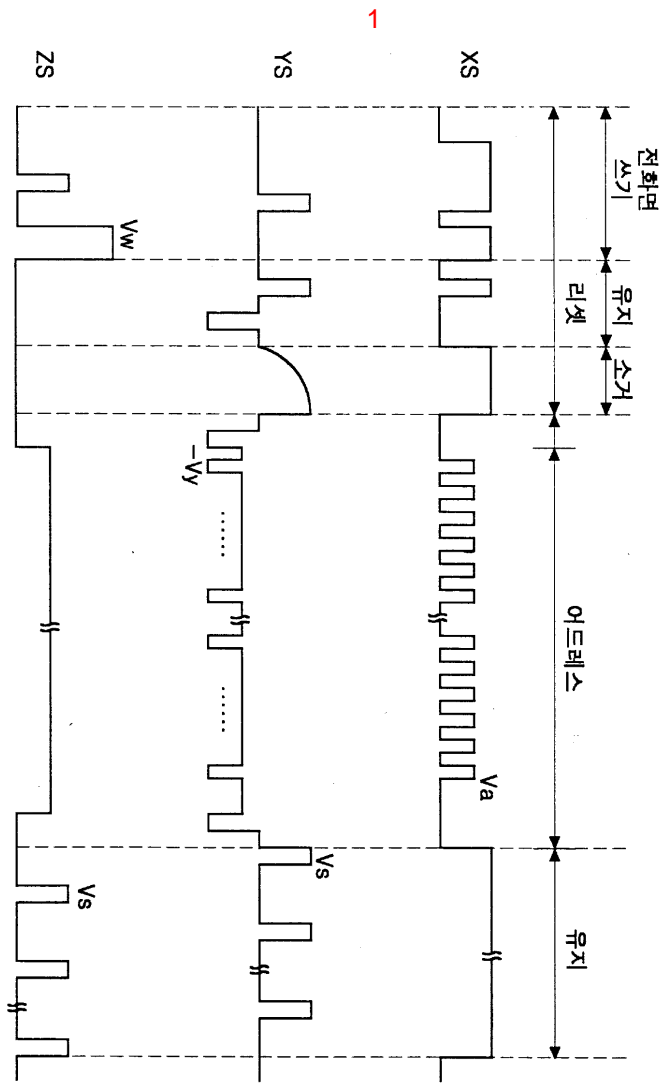

2

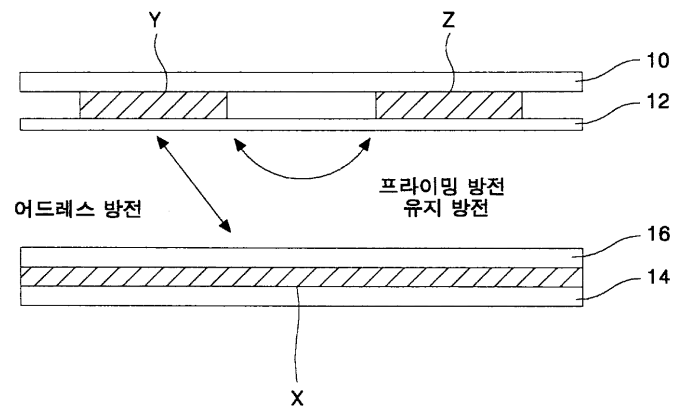

3

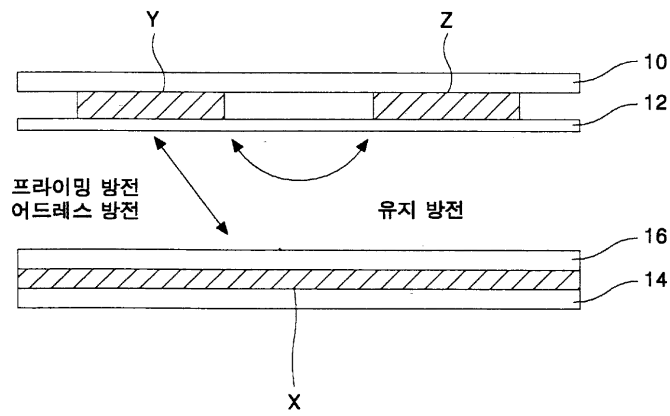

4a

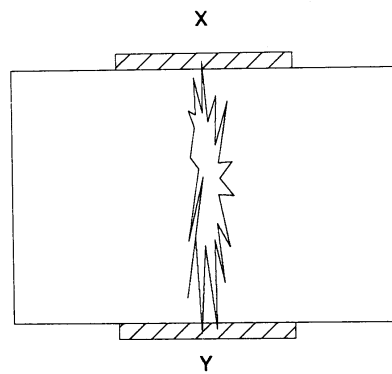

4b

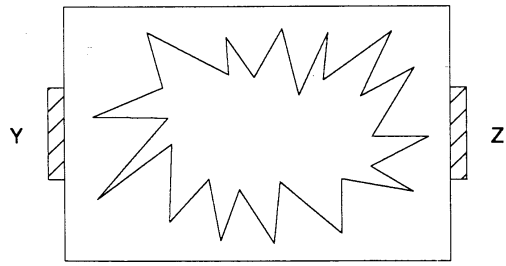

5

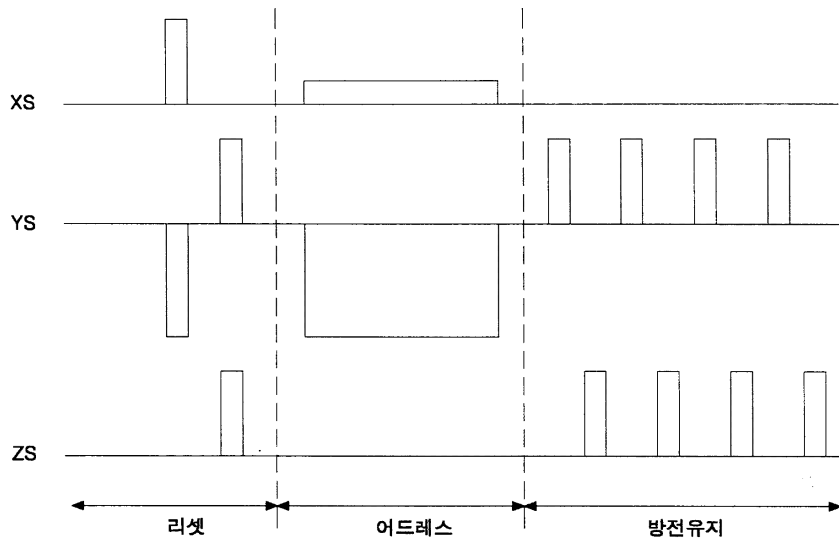

6a

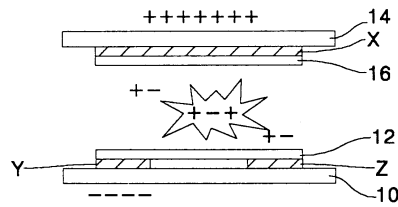

6b

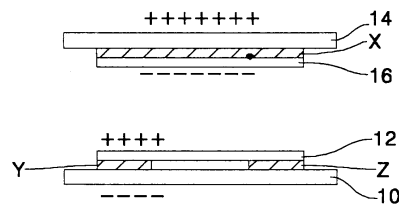

6c

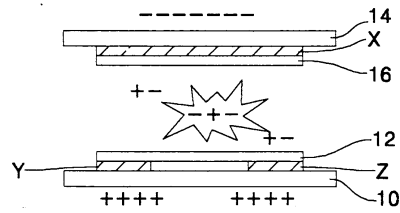

6d

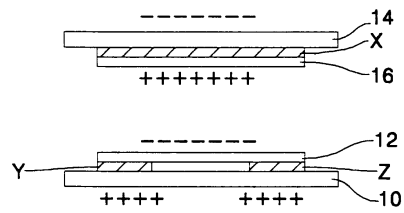

6e

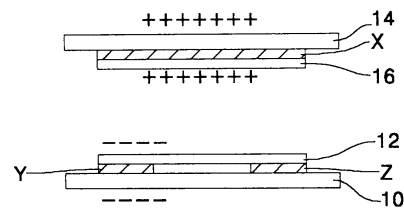

6f

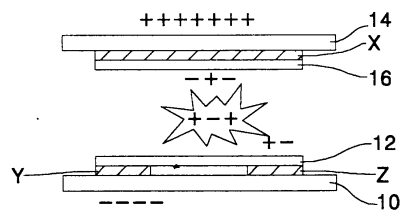

6g

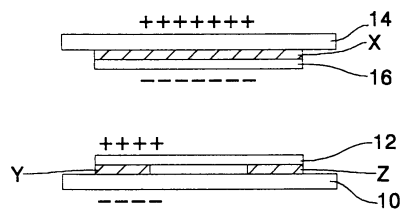

6h

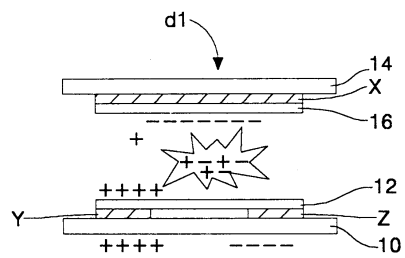

6i

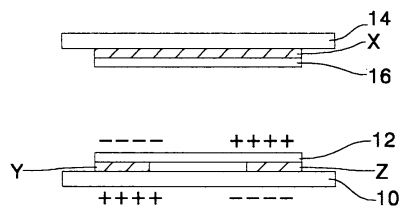

6j

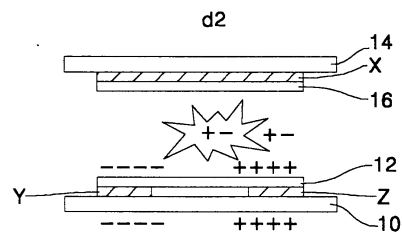

6k

