



EUROPEAN PATENT APPLICATION

Application number : **92310537.3**

Int. Cl.⁵ : **H01Q 1/24**

Date of filing : **18.11.92**

Priority : **18.11.91 US 794086**

Date of publication of application :
26.05.93 Bulletin 93/21

Designated Contracting States :
AT BE CH DE DK ES FR GB GR IE IT LI LU NL PT SE

Applicant : **MOTOROLA, INC.**
1303 East Algonquin Road
Schaumburg, IL 60196 (US)

Inventor : **Growney, Robert L.**
21 Champlain Road
South Barrington, Illinois 60010 (US)
Inventor : **Balzano, Quirino**
7000 S.W. 7 Street
Plantation, Florida 33317 (US)

Representative : **Dunlop, Hugh Christopher et al**
Motorola European Intellectual Property
Operations Jays Close Viables Industrial
Estate
Basingstoke, Hampshire RG22 4PD (GB)

Embedded antenna for communication devices.

A radio communication device (300) having a display terminal (100) includes a glass portion (102) with an antenna (108) deposited thereon. The radio communication device (300) also includes a receiver (408) for receiving a radio communication signal. Radio communication signals are coupled to the receiver (408) via the antenna (108). In another aspect of the present invention, the radio communication device (300) includes a metal frame (206) which operates as its antenna and secures the display terminal (204) to the radio communication device (300).

FIG. 3

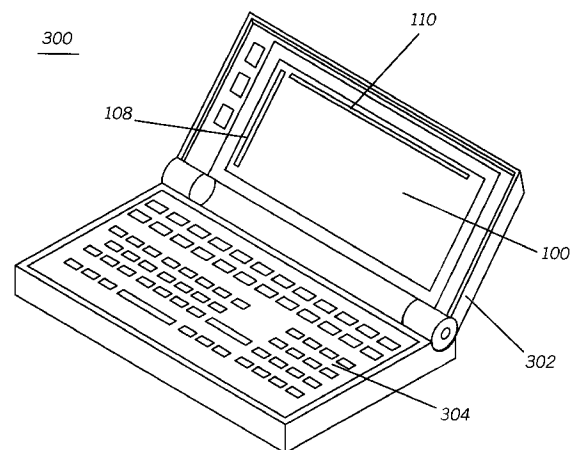

Technical Field

This invention relates generally to antennas, for example to embedded antennas for communication devices.

Background

Antennas for portable communication devices are either internal or external. In the latter, a dipole or a loop antenna is externally connected to the communication device via an antenna coupler providing a means for receiving radio frequency signals. In internal applications, however, antennas are generally printed on a PC board or are placed in a housing in the form of conductive elements. A conventional internal antenna is usually housed in a hollow space enveloped by a housing or casing of a communication device. The use of internal antennas is cosmetically preferred over their external counterparts. These antennas, however, require additional housing volume. As the size of communication devices shrinks the allocation of additional volume to accommodate the antenna becomes less appealing. With external antennas being aesthetically unappealing and internal antennas demanding highly valuable interior radio space, a need exists for an antenna that overcomes the deficiencies of the prior art.

Summary of the Invention

A radio communication device is provided having a display terminal. The display terminal includes a glass portion with an antenna located thereon. The radio communication device also includes a receiver for receiving a radio communication signal. Radio communication signals are coupled to the receiver via the antenna. In another aspect of the present invention, the radio communication device includes a metal frame which operates as its antenna and secures the display terminal to the communication device.

It will be understood that throughout this description and in the claims, the expression "glass" extends to any transparent or semi-transparent material such as perspex or other plastics material suitable for liquid crystal displays, light emitting displays, flat cathode ray tube displays or other displays.

Description of the Drawings

FIG. 1 shows a glass display terminal in accordance with the present invention.

FIG. 2 shows a glass display terminal having a metal frame in accordance with the present invention.

FIG. 3 is an isometric diagram of a communication device in accordance with the principles of the present invention.

FIG. 4 is a block diagram of a communication de-

vice in accordance with the principles of the present invention.

FIG. 5 shows a predicted radiation pattern of the antenna in accordance with the present invention.

Description of the Preferred Embodiment

Referring to FIG. 1, a display 100, preferably Liquid Crystal Display (LCD) is shown in accordance with the principles of the present invention. The display 100 includes a glass 102 which includes an active portion 104 where data can be written unto. Connectors 106 are provided to couple the display 100 to other elements of the electronic device in which the display 100 is a part of. Printed on the glass 102 in areas outside the active display area 104 are antennas 108 and 110. Well known technologies including thick film may be used to print the antennas 108 and 110 on the glass 102. The combination of antennas 108 and 110 provides for diversity in the reception of variably polarized waves. The former performs optimally in capturing vertically polarized electromagnetic waves. Horizontally polarized waves are more efficiently received by the antenna 110. It is obvious that the use of diversity antennas, although improving reception, is not necessary. The presentation of the combination of the two antennas 108 and 110 is intended to illustrate the diversity of the present invention and should not be construed as a limitation thereof. Consequently, antennas 108 and 110 can be incorporated in the display 100 individually or in combination. Radio frequency signals are received by the antennas 108 and 110 and fed into appropriate circuitries for further processing. The housing of the electronic device comprising the display 100 normally includes an inner layer of metallic surface to provide shielding for the display 100. This shield which faces the back of the glass 102 can be used by the antennas 108 and 110 for additional gain. The coupling may be accomplished via feed through or clamp through techniques, well known in the art.

Referring now to FIG. 2, an alternative embodiment of the present invention is shown. A display 200 is shown to include a printed circuit board 202 comprising a number of electronic components 208A-208D and a display 204. The electronic components 208A-208D are preferably drivers and support circuitry's to drive the display 204. A frame 206, being preferably metallic, is used to hold the display 204 to the printed circuit board 202. Clamps 210A and 210B are used either alone or in conjunction with other clamps (not shown) to secure the glass 204 to the PC board 202. The electrical connection between the glass 204 and the PC board 202 may be made via any available mullet-pin connectors or elastomers. In this embodiment, the frame 206 may be used as an antenna. Radio frequency signals are received by the frame and coupled to the receiver circuitry for decoding. The

coupling of the frame 206 to the receiver circuit may be via spring loaded contacts that may be incorporated both on the frame and the receiver. Interruptions in the frame 206 may be made at strategic locations to provide the desired antenna performance at various frequencies.

To summarize, an antenna structure is shown for use in communication devices having display terminals. The preferred embodiment of the present invention takes advantage of the inactive glass areas. Antennas 108 and 110 can be used to receive radio frequency signals without requiring additional space for separately coupled antennas. A metal film may be printed, pasted, sputtered, or plated on the display 100 to form the antennas 108 and 110. The plating may be accomplished via sputtering and then photo defining the pattern on the glass 102.

Referring now to FIG. 3, a flip top communication device is shown to further illustrate the principles of the present invention. The communication device 300 includes a display section 302, and a keyboard section 304. The display section 302 includes the display 100 with its associated antennas 108 and 110. It can be seen how the flip top design is used to reduce the overall volume of the device 300. It is in line with this size reduction that the benefits of the present invention are observed. In this invention, the integrity of the device 300 as being a small hand held product can be kept without having to forfeit the ability to efficiently receive communication signals.

Referring to FIG. 4, a block diagram of the communication device 300 is shown in accordance with the principles of the present invention. The communication device 300 includes a receiver 408 coupled to the antenna 206 via an antenna coupler 412. A radio frequency signal available at the antenna 206 is coupled to the input of the receiver 408 via the antenna coupler 412. The received radio frequency signal is recovered by the receiver 408 and coupled to the controller for appropriate presentation. Data messages are decoded by the controller 404 and stored or displayed on the display 100. Voice messages are coupled to the speaker 414 via the audio circuit block 410. The audio circuit block 410 contains audio gating circuits which control the gating of audio to the speaker 414. The gating of the audio circuits is controlled by the controller 404. Information entered at the keyboard are coupled to the controller 404 for appropriate processing. Note that the antenna 206 and the display 200 are not included as one block because they are operatively different. Although their mechanical attachment may imply their structure as being one, the electrical coupling is totally different and therefore one will not operationally interfere with the other.

FIG. 5 shows a predicted antenna pattern chart 502 in the vertical plane of the antenna of the present invention. The pattern 502 is shown to be relatively symmetrical and substantially above horizon pattern.

A top view of the device 300 is shown along with the viewing direction shown by an arrow 504.

Other embodiments may use the same general principle to achieve similar results without significantly departing from the spirit of the present invention. Namely, a loop antenna may be formed by having one of its portions printed on the glass 102 and the remainder of the loop formed around the internal wall of the display section 302. Other antennas may be entirely printed on the glass 102. The actual antenna whether it is printed, plated, or framed is a function of the particular geometry of the device 300 and its operating frequency.

Size reduction in electronic devices has always been a major objective of designers. Recently great advances have been realized in reducing the size of electronic components which make the workings of these electronic devices. With these advances, reduction to the size of a credit card has been achieved in some communication devices. Traditional antennas, internal or external, hardly meet the stringent size requirements of such devices. However, the antennas 108, 110, and 206 as described by the principles of the present invention are ideal for such applications. A significant benefit of the present invention is that it is no longer necessary to sacrifice the appearance of the communication device in order to achieve performance.

Claims

1. An electronic device, comprising:
 - a display terminal;
 - a receiver for receiving a radio frequency signal; and
 - an antenna disposed on the display terminal for coupling the radio frequency signal to the receiver.
2. The electronic device of claim 1, further including a ground plane to provide additional gain for the antenna.
3. The electronic device of claim 1, wherein the display terminal includes a Liquid Crystal Display (LCD).
4. A radio, comprising:
 - a display having a glass portion;
 - an antenna disposed on the glass portion of the display; and
 - a receiver coupled to the antenna for receiving a radio communication signal.
5. The radio of claim 4, wherein the display includes a ground plane.

6. The radio of claim 4, wherein the display comprises a Liquid Crystal Display (LCD).
7. The radio of claim 4, wherein the antenna is a loop antenna. 5
8. A communication device for receiving a radio frequency communication signal, the device comprising:
- a liquid crystal display having a glass portion; 10
 - at least one loop antenna printed on the glass portion;
 - a metal frame for securing the display to the device, the frame providing the return path for the at least one loop antenna; and 15
 - a receiver coupled to the antenna for receiving the radio frequency communication signal. 20
9. A communication device for receiving a radio frequency communication signal, the communication device comprising:
- a display having a glass portion;
 - a receiver for receiving the radio communication signal; and 25
 - a metal frame antenna for coupling the radio communication signal to the receiver and mechanically securing the display to the communication device. 30
10. A communication device for receiving a radio frequency communication signal, the device comprising:
- a liquid crystal display having a glass portion; 35
 - at least one loop antenna printed on the glass portion; and
 - a receiver coupled to the antenna for receiving the radio frequency communication signal. 40

45

50

55

FIG.1

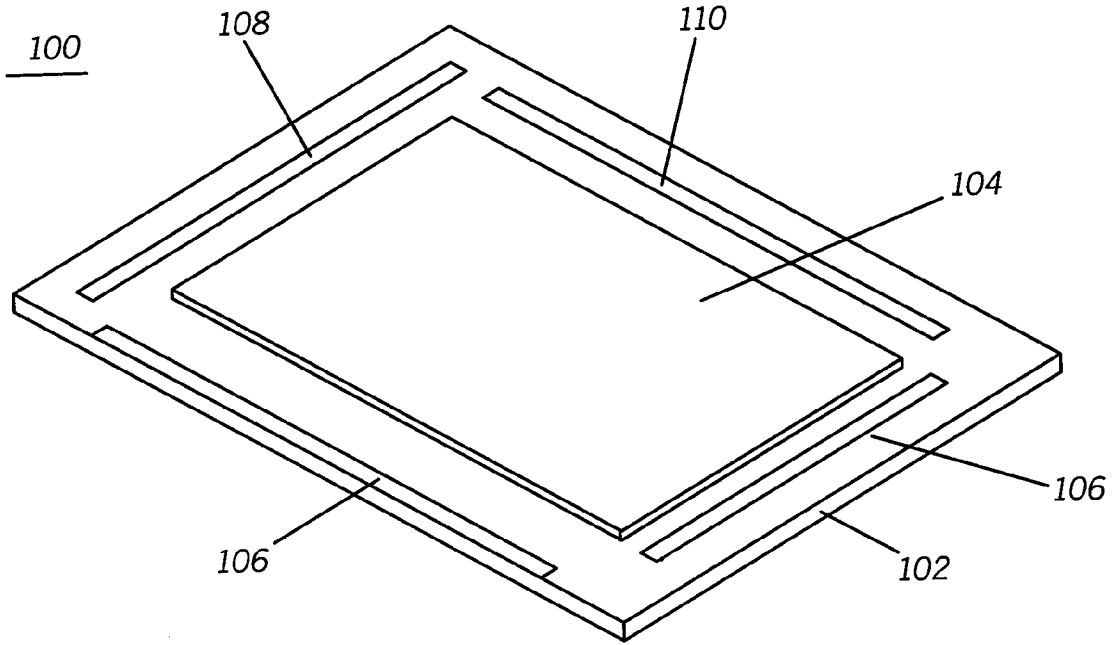

FIG.2

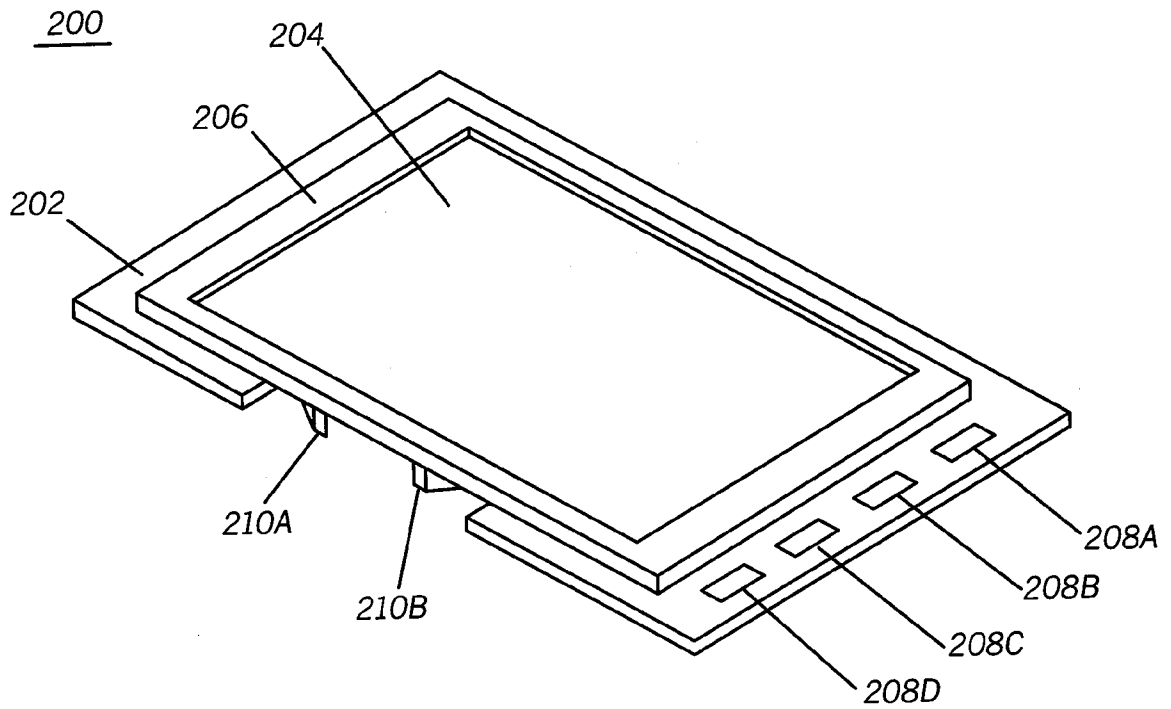

FIG. 3

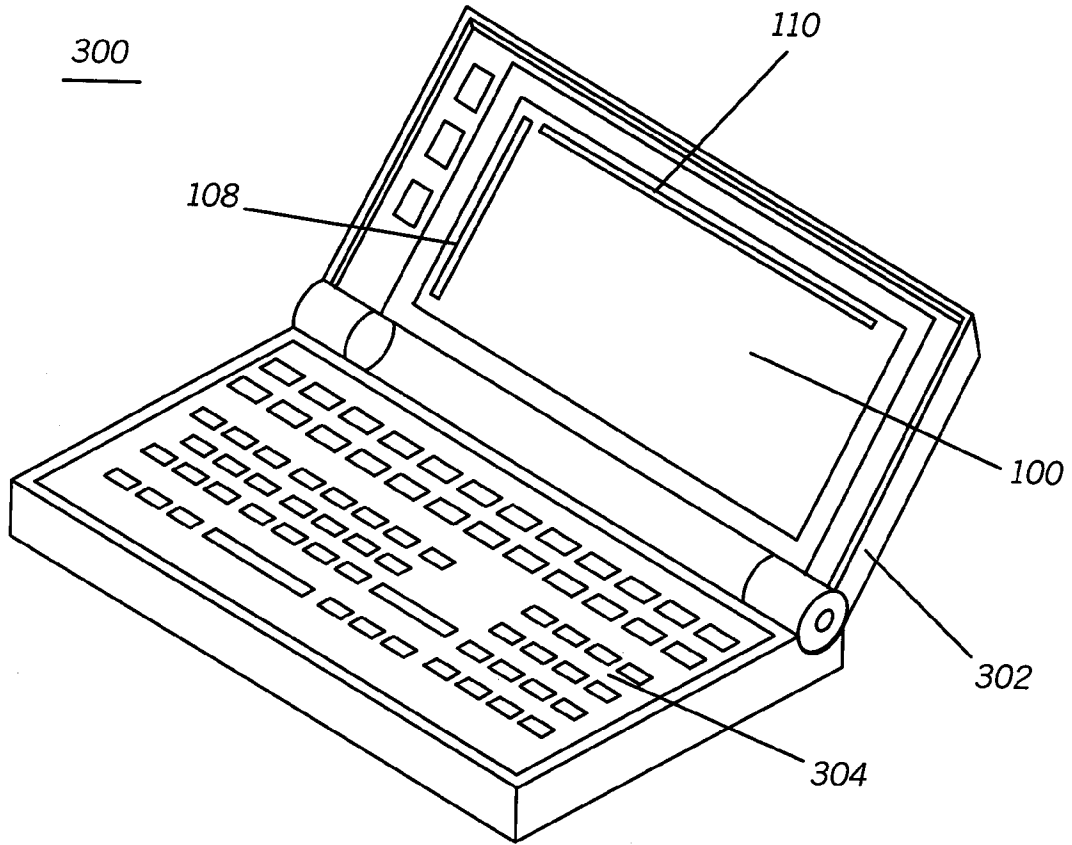
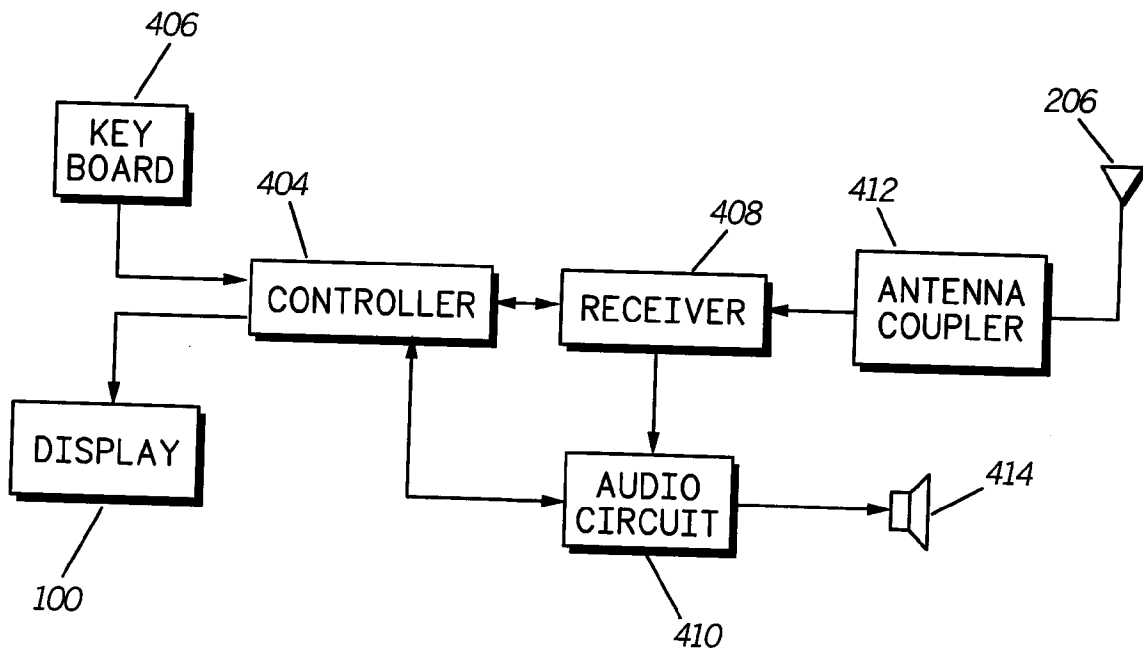

FIG. 4



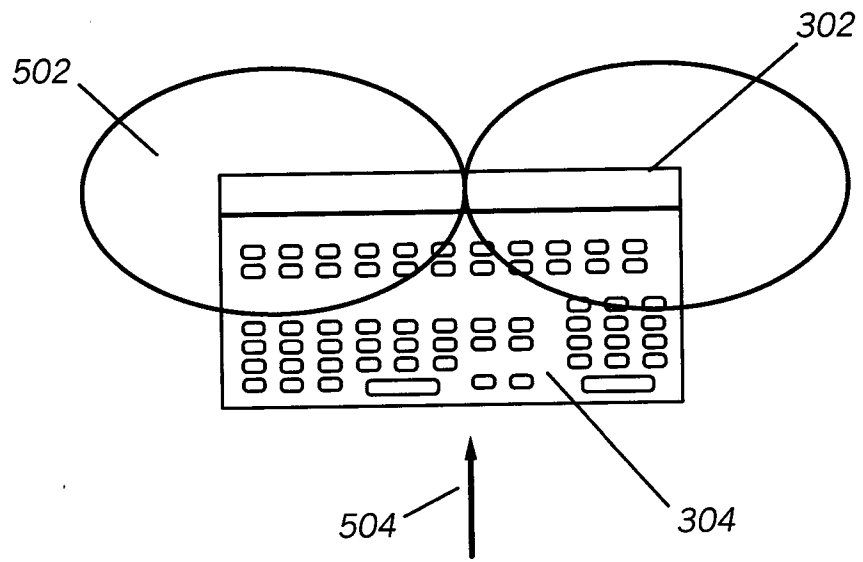

FIG. 5



European Patent
Office

EUROPEAN SEARCH REPORT

Application Number

EP 92 31 0537

DOCUMENTS CONSIDERED TO BE RELEVANT			
Category	Citation of document with indication, where appropriate, of relevant passages	Relevant to claim	CLASSIFICATION OF THE APPLICATION (Int. Cl.5)
Y	GB-A-2 217 538 (NEC) * page 2, line 5 - line 25; figures 1-4 * ---	1-10	H01Q1/24
Y	US-A-4 727 377 (YOTSUYA ET AL.) * abstract; figures 1,10-16 * ---	1-10	
A	EP-A-0 274 592 (YAGI ANTENNA) * column 2, line 20 - line 41; figure 2 * * column 4, line 44 - column 5, line 12; figures 1-31 * ---	1-10	
A	US-A-5 048 118 (BROOKS ET AL.) * claims 1-11; figures 1-4 * ---	1,4,8-10	
A	US-A-4 644 366 (SCHOLZ) * abstract; figures 1-5 * ---	1,4,8-10	
A	EP-A-0 347 151 (DOWTY MINING) * claims 1-10; figures 1-4 * -----	1,4,8-10	
			TECHNICAL FIELDS SEARCHED (Int. Cl.5)
			H01Q
The present search report has been drawn up for all claims			
Place of search THE HAGUE		Date of completion of the search 04 MARCH 1993	Examiner ANGRABEIT F.F.K.
CATEGORY OF CITED DOCUMENTS X : particularly relevant if taken alone Y : particularly relevant if combined with another document of the same category A : technological background O : non-written disclosure P : intermediate document		I : theory or principle underlying the invention E : earlier patent document, but published on, or after the filing date D : document cited in the application L : document cited for other reasons & : member of the same patent family, corresponding document	

EPO FORM 1503 03.82 (P0401)