

United States Patent

[11] **3,613,684**

[72] **Inventor** David S. Sheridan
 Hook Road, Argyle, N.Y. 12509
 [21] **Appl. No.** 859,413
 [22] **Filed** Sept. 19, 1969
 [45] **Patented** Oct. 19, 1971

3,128,769	4/1964	Scislowicz	128/348
3,288,901	11/1966	Clark	128/349 X
3,444,860	5/1969	Harrell	128/349
3,459,189	8/1969	Alley et al.	128/347
3,515,137	6/1970	Santomieri	128/348 X

FOREIGN PATENTS

885,917	8/1953	Germany	128/349
---------	--------	---------------	---------

Primary Examiner—Dalton L. Truluck
Attorney—Kemon, Palmer & Estabrook

[54] **TROCAR CATHETERS**
 3 Claims, 9 Drawing Figs.
 [52] **U.S. Cl.**..... 128/347,
 128/350
 [51] **Int. Cl.**..... A61b17/34,
 A61m 27/00
 [50] **Field of Search**..... 128/348-351,
 347, 221, 215, 214.4

[56] **References Cited**
 UNITED STATES PATENTS
 402,902 5/1889 Chapman 128/349
 2,393,003 1/1946 Smith 128/349
 3,127,894 4/1964 Smith 128/347

ABSTRACT: A trocar catheter is formed with a rigid shaftlike stylet and an encircling catheter made of plastic material. The catheter has a molded rigid distal end member with a conical shape, a closed rounded tip fixed to a flexible tube, and at least one fluid opening through the side. The rigid distal end member has an interior that conforms to the shape of the stylet tip. The device may be used in emergency cases where the catheter is forced through the chest wall of a patient over the stylet which is then withdrawn to let fluid pass through the catheter or for suprapubic cystostomy procedures.

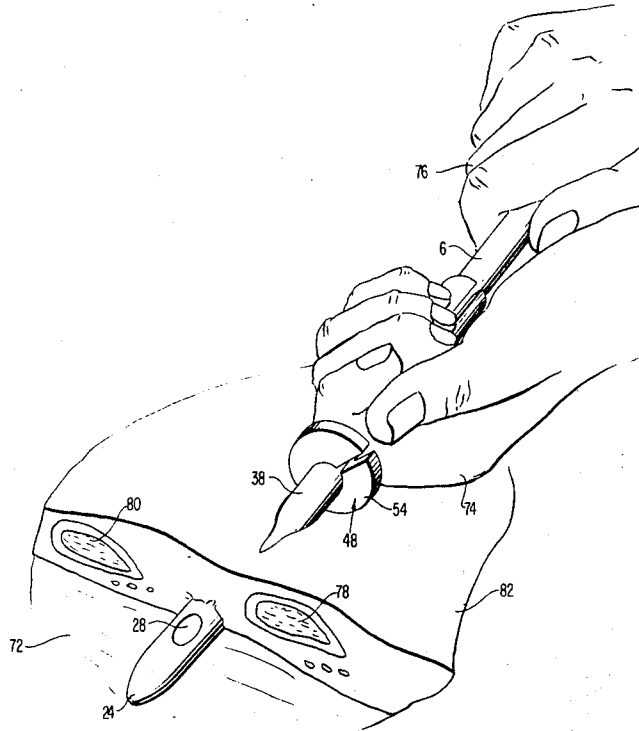

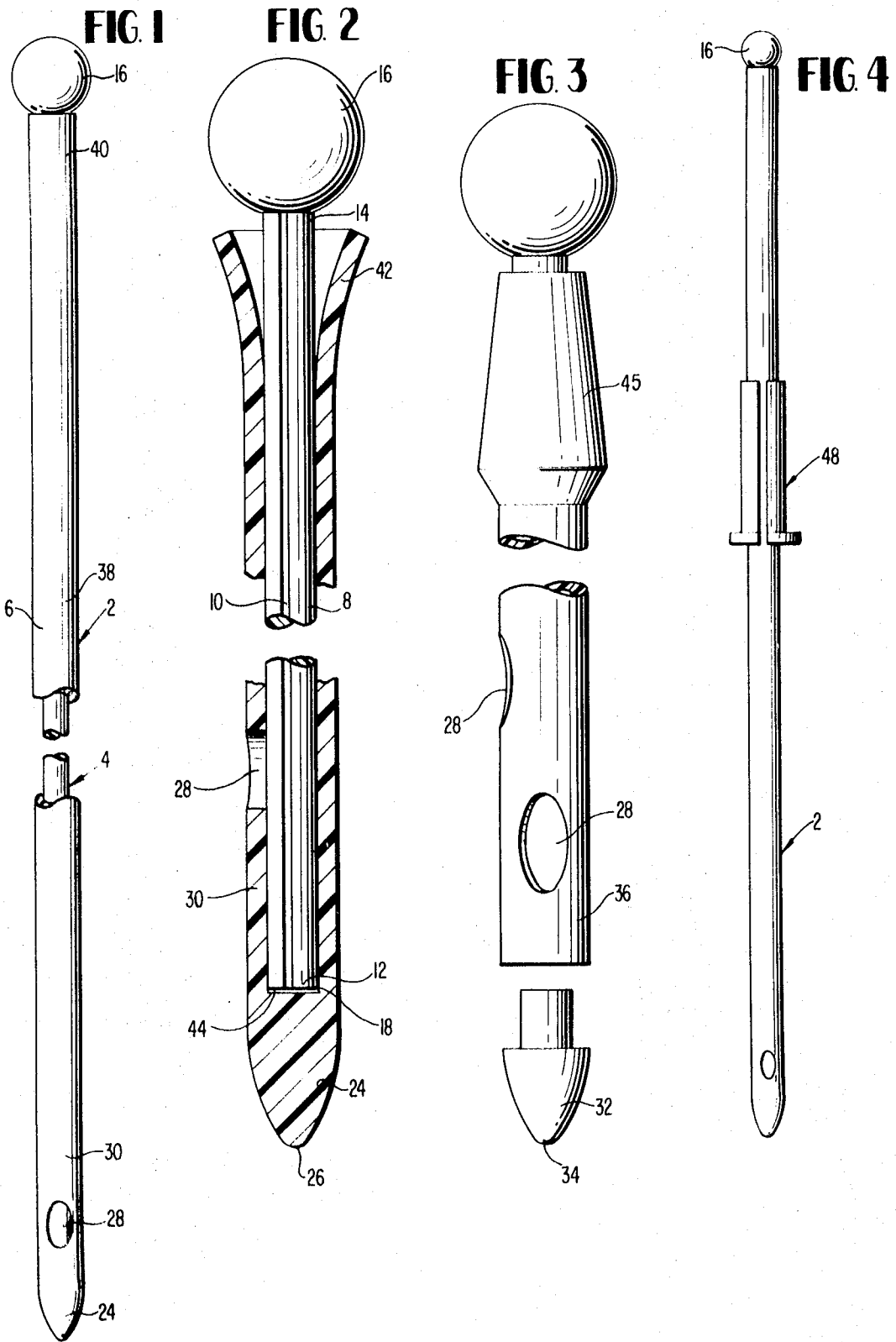

FIG. 6

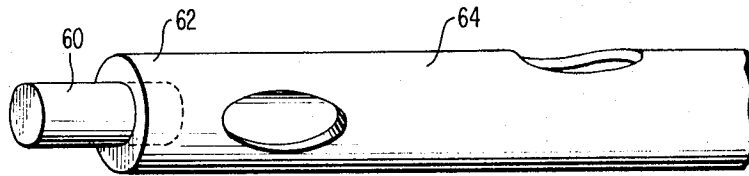

FIG. 7

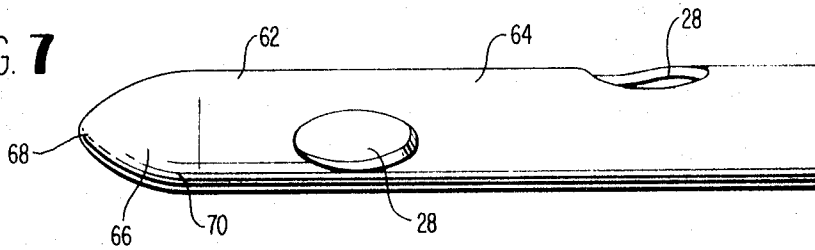

FIG. 8

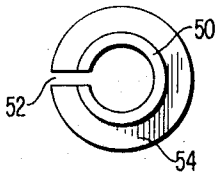

FIG. 9

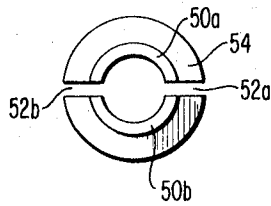
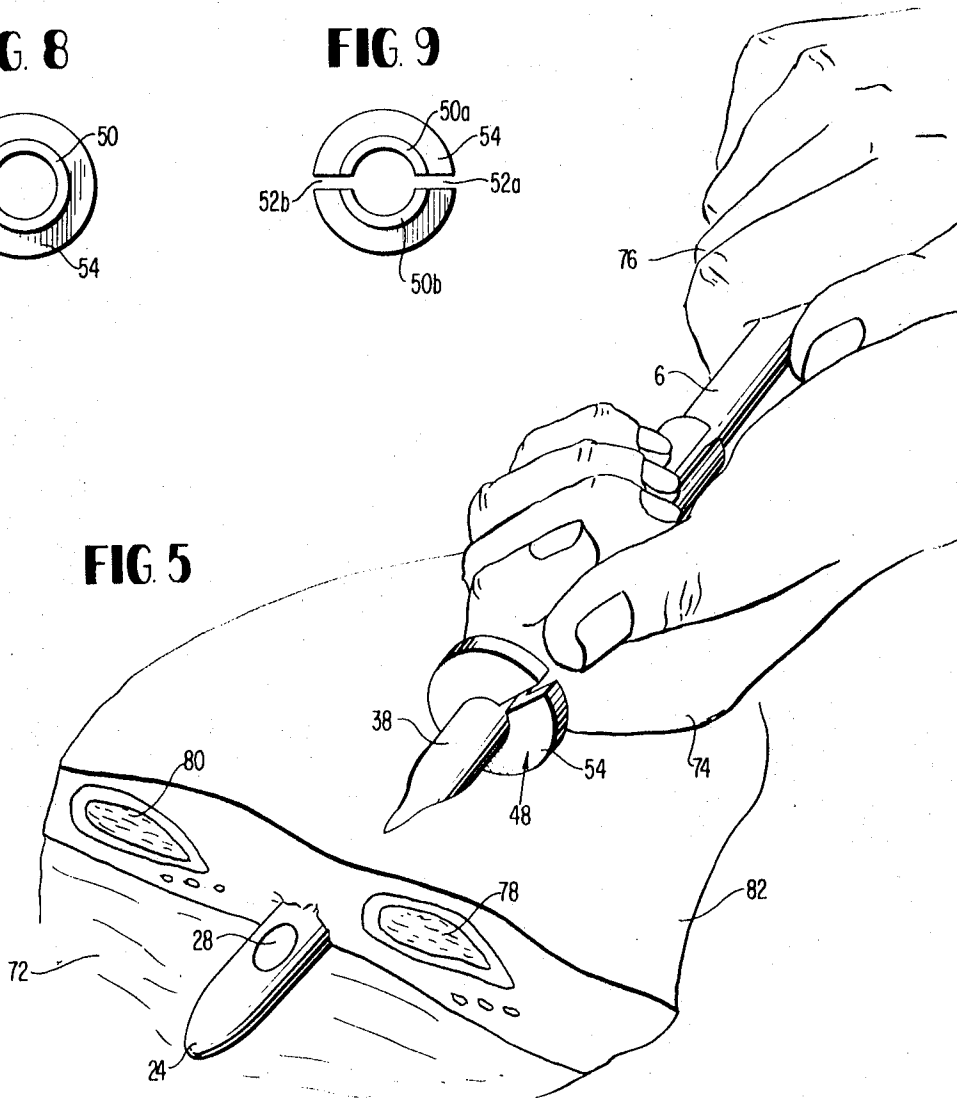

FIG. 5



TROCAR CATHETERS**BACKGROUND OF THE INVENTION**

The present invention relates to trocar catheters which are designed primarily for insertion through a chest or stomach wall of a patient in order to allow fluid within a body cavity of the patient to be withdrawn. A procedure of this type is especially important in emergency cases where patients may require the withdrawal of blood, air or other fluid in the pleural cavity because of an accident such as an automobile collision, assault by a firearm or the like. Also, in suprapubic cystostomy penetration of the stomach wall may be necessary for drainage of the bladder when urethral catheterization cannot be performed or for the taking of sterile urine samples.

Situations which require the use of trocar catheters are generally of an emergency nature requiring prompt relief of the patient's critical condition which may include a collapsed lung, air or fluid in the pleural cavity or similar conditions which require creation of a fluid channel directly through the chest or stomach wall of the patient. Hence, catheters of this type must be designed for reliability, but of simple and highly effective construction. To avoid possible additional damage to the patient, the trocar catheter must be capable of insertion through the chest or stomach wall of the patient without flexing or deviation from the desired path, e.g., passage between a pair of ribs. Further, the penetration of the catheter must be accomplished with a minimum of injury to nerves or vessels and without inflicting trauma on the expanding lung or collapsing bladder. Additionally, it is desirable for the catheter device to permit anyone using the catheter upon the patient to estimate the approximate position within the patient of the distal end of the catheter and to give some indication as to when the distal end of the catheter has entered the pleural area or bladder.

As instruments for treatment of both human and animal bodies, trocars are well known. For example, they are widely used in embalming (see U.S. Pat. No. 2,639,484). Although they more generally are employed to introduce or withdraw fluids from a body, they may be used to extract tissue such as in a biopsy (see U.S. Pat. No. 2,541,542).

Trocar catheters may be of a single element construction such as a catheter of rigid or semirigid material with a pointed end capable of penetrating a body (see U.S. Pat. No. 1,273,542). On the other hand, it is known to employ stylets with catheters to provide the catheter which is of flexible construction to obtain a sufficient degree of rigidity to permit the catheter to be properly placed within a patient's body (see U.S. Pat. No. 2,118,631). The combination of a rigid stylet and an encircling catheter has been used in the past in the creation of catheter devices of the general type to which the present invention pertains, namely, trocar catheters.

Notwithstanding these prior developments in the field of medicosurgical devices and particularly trocars and catheters, further improvements are needed in the construction of trocar catheters. These include means for insuring correct, effective or nontraumatic insertion of the catheter through the chest or stomach wall of a patient and means to insure the catheter penetrates to a required depth without overpenetration which can cause severe injury to the patient.

OBJECTS

A principal object of this invention is the provision of new improvements in construction of trocar catheters.

Further objects include the provision of:

1. Trocar catheter devices which prevent the catheter upon insertion in a patient from penetrating beyond a required depth.

2. Such improved catheters which give the surgeon or physician using the device a visual indication as to when the distal end has entered the pleural cavity, bladder or other desired body cavity.

3. Improvements in trocar catheter construction which enable insertion of the catheter within a patient to be accom-

plished with a minimum of danger of bodily injury to the patient.

4. Improved ways of making trocar catheters which permit them to be manufactured in large numbers at low cost so that they can be treated as single-use disposable items.

5. Trocar catheters which when inserted in a patient, fill the entire body puncture, creating effective sealing of the catheter in the body to reduce possibility of infection and provide for proper functioning of the catheter.

Other objects and further scope of applicability of the present invention will become apparent from the detailed description given hereinafter; it should be understood, however, that the detailed description, while indicating preferred embodiments of the invention, is given by way of illustration only, since various changes and modifications within the spirit and scope of the invention will become apparent to those skilled in the art from this detailed description.

SUMMARY OF THE INVENTION

These objects are accomplished according to the present invention by the provision of trocar catheters which comprise:

A. a rigid stylet including:

a. a rigid shaft of circular cross section,

b. an enlarged hand-engaging member attached to the proximal end of the shaft, and

B. a catheter formed of plastic material including:

a. a rigid distal end member molded of rigid plastic material with a smooth, close conical-shaped tip,

b. at least one fluid opening through the sidewall, e.g., near the distal end,

c. a proximal end portion,

d. a central body portion of cylindrical shape integral with said proximal end portion and joined to said distal end member,

e. said proximal end portion and central body portion being formed of flexible plastic material,

f. the interior of said distal end member being molded to conform in shape to the tip of said rigid stylet, and

g. the interior of said central body portion being formed to closely encircle the surface of said rigid shaft.

Advantageously, the rigid stylet which constitutes the inner element of the new catheter devices has a square tip and the stylet is made of metal. Further, the preferred new catheters have a distal end member which has an outside surface of the same circumference as the circumference of the central body portion of the catheter and both of these are made of plastic material that is transparent.

In the preferred form of the new trocar catheters, there is included a depth-penetration-limit means which movably embraces the outer surface of the central body portion of the catheter. Advantageously, this comprises a slotted tubular member having a slotted radially extending collar affixed upon one end. Such tubular member may be molded in two complementary half-sections of plastic material. Alternatively, it may be a singular element having a longitudinal slot permitting the member to be compressed inwardly to grip the outer surface of the central body portion of the catheter.

BRIEF DESCRIPTION OF THE DRAWINGS

FIG. 1 is a fragmentary top elevational view of a preferred embodiment of a trocar catheter in accordance with the invention.

FIG. 2 is an enlarged fragmentary side view partially in section of the distal and proximal end portions of the catheter of FIG. 1.

FIG. 3 is an enlarged top exploded view illustrating components used in making one embodiment of the new trocar catheter.

FIG. 4 is a reduced top elevational view of the catheter of FIG. 1 showing the depth of penetration limit means of the catheter device embracing the outer surface of the catheter.

FIG. 5 is a diagrammatic view illustrating placement of the catheter through the chest wall of a patient.

FIG. 6 is a perspective enlarged, fragmentary view of the distal end portion of a catheter of the invention in its course of manufacture.

FIG. 7 is an enlarged, fragmentary side view of the distal end portion of a trocar catheter in accordance with the invention.

FIG. 8 is an end elevational view of one form of depth penetration limit means of the catheter devices in accordance with the invention.

FIG. 9 is an end elevational view of a modified form of depth penetration limit means.

DESCRIPTION OF PREFERRED EMBODIMENTS

Referring in detail to the drawings, a preferred embodiment of a trocar catheter 2 in accordance with the invention comprises a rigid stylet 4 and a catheter 6 formed of plastic material.

The rigid stylet 4 comprises a rigid shaft 8 of circular cross section, a capillary groove 10 extending from adjacent the distal end 12 to the proximal end 14 of the shaft. The proximal end of the shaft has attached thereto an enlarged hand-engaging member 16 which advantageously is a solid plastic ball threaded upon or otherwise fixed to the proximal end of the shaft 8.

In the form of catheter shown in FIG. 2, the tip 12 of the stylet 4 has a square tip 18. The end 24 is formed of rigid plastic material while the remainder of the catheter 6 is formed of flexible plastic material. In the form of catheter shown in FIG. 2, this construction is attained by placing a cylindrical piece of rigid plastic in a heated mold and then forcing a flexible plastic tube in back of the rigid piece. The combination of heat and pressure softens the rigid piece, shapes the free end into a rounded tip 26 and welds the other end of the piece to the tube in a smooth junction. One or more fluid openings 28 extend through the sidewall 30.

In the form of catheter shown in FIG. 3, the catheter 6 comprises a rigid distal end member 32 having a smooth conical-shaped tip 34. The member 24 is preferably molded, such as by injection molding, compression molding, centrifugal casting or the like, of rigid or semirigid plastic material, e.g., nylon, polyvinyl chloride, or equivalent plastic materials. Alternatively, the end member 24 may be formed of metal such as stainless steel by any suitable metalworking technique. Use of transparent rigid or semirigid plastic material for forming the distal end member 24 is preferred. The preformed member 32 is fixed to the tube 36 by cementing, friction welding or in any other suitable manner.

The catheter also comprises the central body portion 38 of cylindrical shape formed integrally with a proximal end portion 40. These are preferably formed of flexible transparent plastic material by extrusion although other plastic-forming methods such as dipping, injection molding, centrifugal casting or the like can be used to form these portions of the catheter. Unpigmented plasticized polyvinyl chloride is an advantageous type of plastic material to use in forming elements 38 and 40 although other flexible materials such as vinyl ester polymers, e.g., E.V.A., and the like may be used and, if desired, these may include pigments or fillers so that the tube is translucent or opaque rather than being transparent. Such pigments may include X-ray opaque material so that part or all of the plastic catheter is opaque to X-rays permitting its position within a patient's body to be readily determined by X-ray examination.

In the embodiment of catheters shown in FIG. 1, the central body portion 38 and proximal end portion 40 are made of uniform wall thickness and constant diameter throughout. Alternatively, the catheter may be formed with variation in diameter and wall thickness, lumen or the like, e.g., the proximal end 40 may be formed with heavier wall thickness, with a funnel construction 42 to provide a female connector end or with a male connector construction 45 to permit the catheter to be attached to auxiliary equipment which may be necessary or desirable in conducting operations on the patient in ac-

cordance with recognized surgical or clinical practice, e.g., as used with standard thoracic catheters.

The length of the rigid distal end member 24 or 32 is not critical although a short length of about 0.5 to 2 cm. is preferred so that maximum length of flexibility in the catheter can be obtained. In order that the entire outer surface of the catheter will be continuously smooth throughout its length, the distal end member 24 or 32 has a circumference identical to the circumference of the central body portion 38, particularly at the joint between these two elements.

The interior surface 44 of the distal end member 24 is molded to conform in shape to the tip 12 of the rigid stylet 4. In the embodiment shown in FIG. 2, the tip 12 of the stylet 4 is square ended and the distal end member 24 has an interior shape to accommodate this square ended stylet.

The catheter 2 preferably includes a depth penetration limit means 48. This may assume various forms but advantageously comprises a tubular member 50 having a longitudinal slot 52 and a radially extending collar 54 which is similarly slotted. The tubular member 50 may have more than one slot and as seen in FIG. 9 a pair of slots 52a and 52b may be used thereby dividing the tubular member 50 into a pair of complementary half-sections 50a and 50b. In the embodiment of the limit means shown in FIG. 8, the tubular member 50 has only a single slot 52. Such limit means can be molded of plastic material such as polyvinyl chloride, polystyrene, nylon or the like or alternatively, it may be cast, machined or otherwise formed of metal.

An alternative method of forming the new trocar catheters is shown in FIGS. 6 and 7. A cylindrical plug 60 of rigid plastic material is placed in the end 62 of the tube 64 made of a flexible formulation of polyvinyl chloride. This assembly is then placed in a mold (not shown) of the desired shape and is heated to a temperature, e.g., 250°-350° F., that melts the plastic and the tube 64 is pushed into the mold to provide pressure to make the softened plastic take the shape of the mold. This creates the distal end 66 in which the rounded tip 68 is rigid with a gradual transition in rigidity the region 70 toward the flexible tube 64. The openings or holes 28 may be formed by known cutting or punching methods before or after the molding operations as described.

Since the trocar catheters of the invention are by their nature often used for emergency cases and under conditions where sterilization equipment is unavailable, it is advantageous for the assembly to be closed in a sealable package in which it can be sterilized such as by exposure to ethylene oxide vapors, gamma radiations or similar techniques known to medicosurgical equipment manufacturers so that the catheter assembly will remain within the package in sterile condition and immediately available in this form upon opening of the package for safe use by the surgeon, physician or other party in attendance of the emergency patient. Also, suitable markings can be formed by printing, staining or the like, on a surface of the stylet or the catheter to indicate any appropriate distance from the pointed tip 68 or one of the openings 28 as may be preferred or required by the surgeon or other party who would use the device. X-ray indicator tips or eyes may also be formed in the catheter.

The method of use of the catheter is illustrated in FIG. 5 in an intercostal penetration to the pleural cavity. The surgeon or other user estimates the distance along the central body portion 38 that penetration into the pleural cavity 72 of the patient, the catheter is to be inserted. A slight incision is made with a scalpel or knife in the skin. The penetration limit member 48 is then placed along the catheter so that the collar 54 is located at this critical position on the catheter 6. The user then grasps the penetration limit member 48 in one hand 74, exerting sufficient pressure on the unit 48 so that it tightly grasps the outer surface of the catheter 6. The proximal end ball 16 is then palmed in the other hand 76 of the operator and the rounded point 24 of the catheter 6 is then placed in the skin incision positioned between a pair of ribs 78 and 80 of the patient in known manner so that the intercostal penetration can be made. This is accomplished by exerting simultaneous

force through the hands 74 and 76 until the distal end member 24 of the catheter 6 penetrates the chest wall 82 of the patient and enters the pleural cavity 72. Once the skin is cut, the slightly blunted tip of the new trocar is quite easily forced through the rest of the tissue into the body cavity. Accidental overpenetration is prevented by the collar 54 of limit means 48 coming to rest against the skin on the chest of the patient. A visual indication is given to the surgeon or other operator that the distal end opening 28 has entered the pleural area since blood or other fluid appears at the proximal end of the catheter by passing along the channel 10. This is not essential, however, and the channel 10 may be omitted in the construction of the stylet. At this point, the stylet 4 is partially withdrawn from the interior of the catheter. The catheter is then clamped off and the stylet is completely withdrawn. To complete the procedure, the proximal end 40 of the catheter will be connected to a closed underwater seal system or any other auxiliary equipment required for the patient under the particular circumstances and the patient's injury or disease and the clamp is removed.

The smooth rigid tip construction of the new trocar catheters permits necessary penetration of the chest or stomach wall to be accomplished without inflicting trauma on the expanding lung or collapsing bladder. Further, with sharp pointed needles or trocar of prior types there is always the danger of puncturing the far wall of the bladder or the lung during the thorocotomy. This is obviated by the rounded rigid tip of the new catheters. Also, where the catheter must dwell in the patient for an extended period, the rounded tip mitigates possibility of puncture or other trauma.

The embodiments of the invention in which an exclusive property or right is claimed are defined as follows:

1. A trocar catheter comprising:

35

40

45

50

55

60

65

70

75

- A. a rigid stylet including:
 - a. a rigid metal shaft of circular cross section,
 - b. a source square tip on the distal end of the shaft, and
 - c. an enlarged hand-engaging member attached to the proximal end of the shaft,
- B. a catheter formed of plastic material including:
 - a. a rigid or semirigid distal end member molded of rigid or semirigid plastic material with a closed conical-shaped, smoothly rounded tip,
 - b. at least one fluid opening through the sidewall,
 - c. a proximal end portion,
 - d. a central body portion of cylindrical shape integral with said proximal end portion and joined to said distal end member,
 - e. said central body portion being formed of transparent flexible plastic material,
 - f. the interior of said distal end member being molded to conform in shape to the square tip of said rigid stylet, and
 - g. the interior of said central body portion being formed to closely encircle the surface of said rigid shaft, and
- C. depth penetration limit means including:
 - a. a slotted tubular member movably embracing the outer surface of said central body portion, and
 - b. a slotted radially extending collar fixed upon one end of said tubular member.
2. A trocar catheter as claimed in claim 1 wherein said tubular member and collar are formed in complementary half-sections.
3. A trocar catheter as claimed in claim 2 wherein said half-sections are molded of plastic material.