

No. 676,389.

Patented June 11, 1901.

A. MILL.
RADIAL DRILL.

(Application filed Oct. 20, 1900.)

(No Model.)

3 Sheets—Sheet 2.

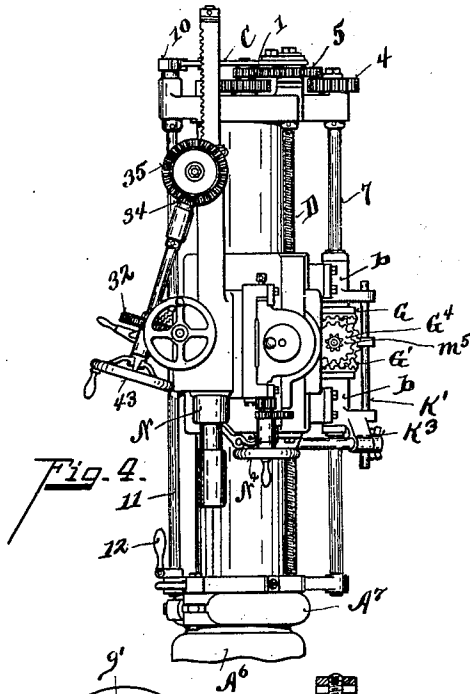

Fig. 2.

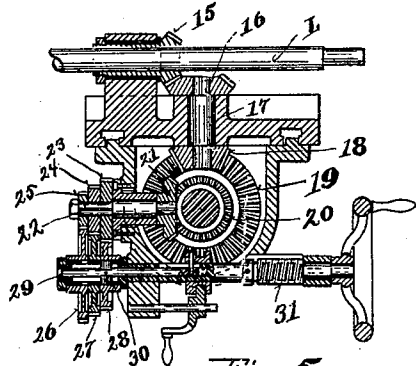

Fig. 5.

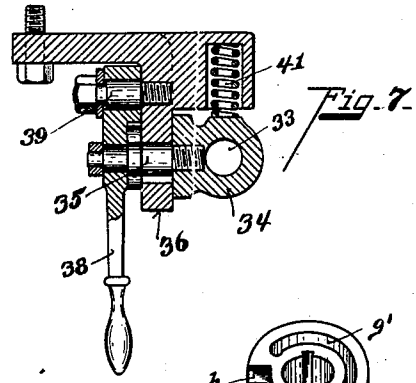

Fig. 7.

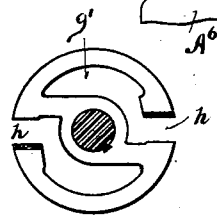

Fig. 15.

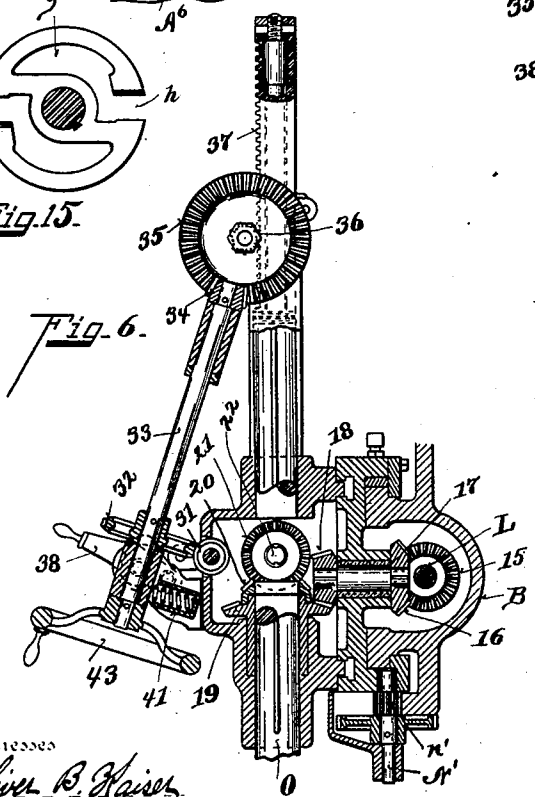

Fig. 6.

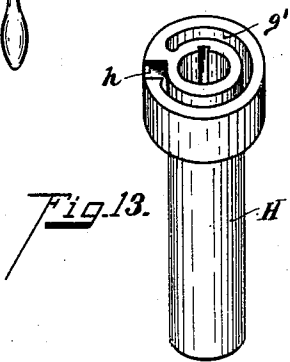

Fig. 13.

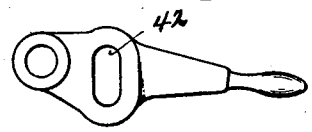

Fig. 14.

Witnesses
Oliver B. Haines
Pearl McMichael

Inventor
Anton Mill
 By *Wood & Wood*
 Attorneys

No. 676,389.

Patented June 11, 1901.

A. MILL.
RADIAL DRILL.

(Application filed Oct. 20, 1900.)

(No Model.)

3 Sheets—Sheet 3.

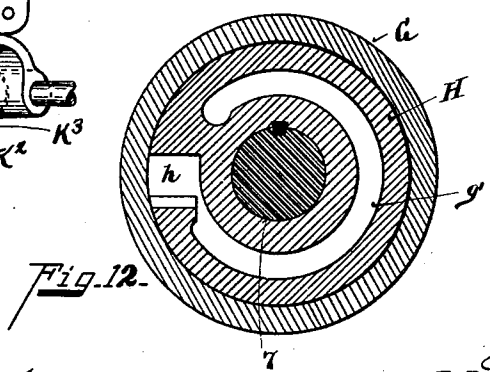
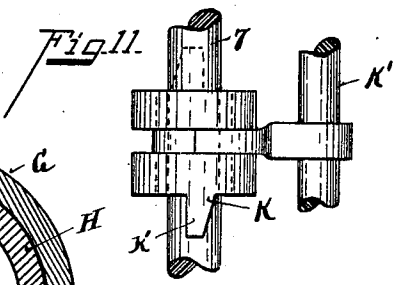
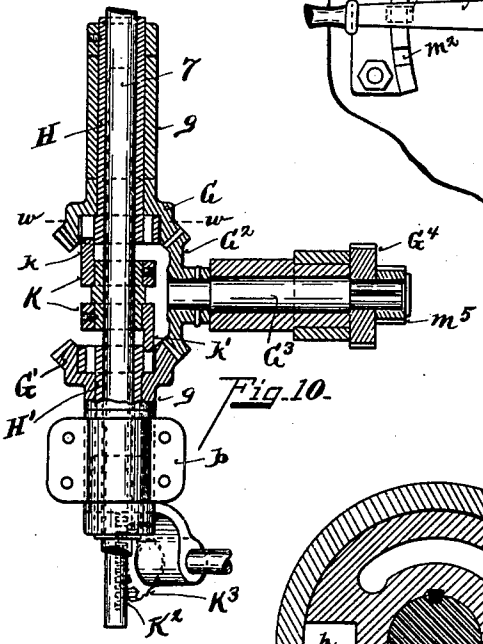
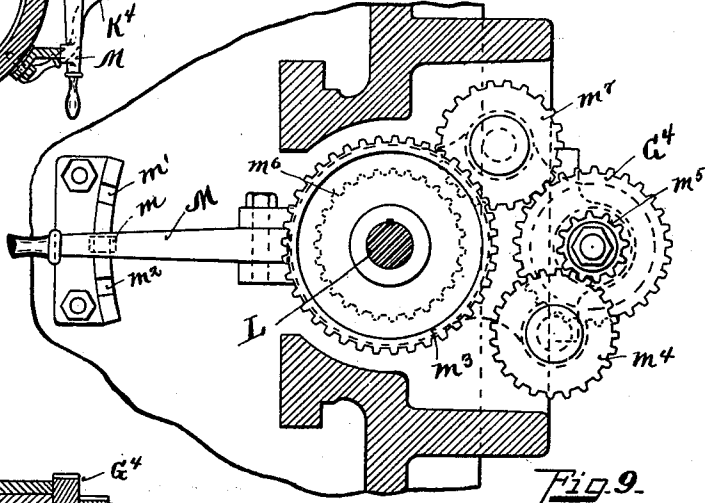
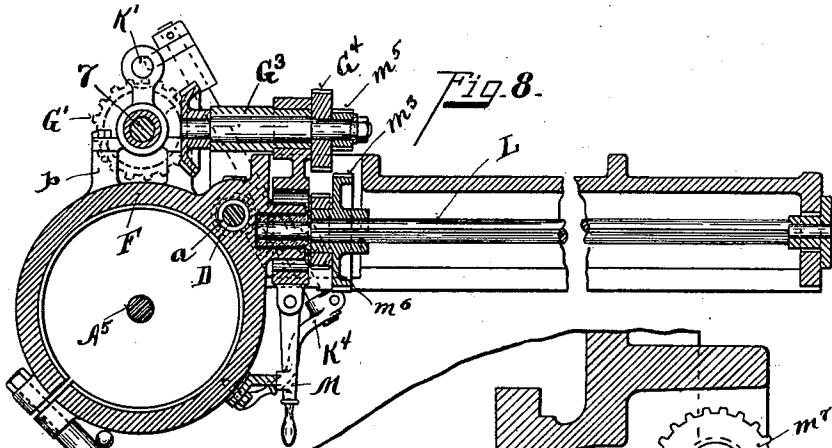

Witnesses

Oliver B. Kaiser
Pearl M. Michael

Inventor

Anton Hill

By *Wood & Wool*

Attorneys

UNITED STATES PATENT OFFICE.

ANTON MILL, OF CINCINNATI, OHIO, ASSIGNOR TO THE AMERICAN TOOL WORKS COMPANY, OF SAME PLACE.

RADIAL DRILL.

SPECIFICATION forming part of Letters Patent No. 676,389, dated June 11, 1901.

Application filed October 20, 1900. Serial No. 33,694. (No model.)

To all whom it may concern:

Be it known that I, ANTON MILL, a citizen of the United States, residing at Cincinnati, in the county of Hamilton and State of Ohio, have invented certain new and useful Improvements in Radial Drills, of which the following is a specification.

One object of my invention is first to provide improved means for reversing the motion of the drill-spindle preferably applied to the vertical transmitting-shaft.

Another object of my invention is to provide mechanism for accomplishing a quick return of the drill-spindle either by hand or power devices by will of the operator.

Another object of my invention is to provide multiple-speed devices, mounted on the drill-stock for feeding the drill-spindle, which are mounted on the drill-stock.

Another object of my invention is to provide variable-speed mechanism for driving the screw-shaft, which raises and lowers the radial arm, the said gears being so arranged that the screw-shaft is driven faster in lowering the arm and driven slower with greater power when raising the arm.

Other features of my invention will be more fully set forth in the description of the accompanying drawings, forming a part of this specification, in which—

Figure 1 is a front elevation of my radial drill. Fig. 2 is a top plan gear mounted on the column. Fig. 3 is a section on line *x x*, Fig. 2. Fig. 4 is an end elevation of Fig. 1 with the base removed. Fig. 5 is a section on line *y y*, Fig. 1. Fig. 6 is a horizontal section of the feeding mechanism. Fig. 7 is a longitudinal section of the locking devices attached to the feeding mechanism shown in Fig. 6. Fig. 8 is a horizontal section on line *z z*, Fig. 1. Fig. 9 is an enlarged plan on line *v v*, Fig. 1. Fig. 10 is an enlarged sectional view of the clutch mechanism. Fig. 11 is a plan view of the sliding clutch member. Fig. 12 is a section on line *w w*, Fig. 10. Fig. 13 is a perspective view of the clutch-sleeve. Fig. 14 is a plan view of the feeding-lock arm. Fig. 15 is a modification of the clutch. Fig. 16 is a modification of Fig. 2, and Fig. 17 is a section of the same.

A represents the bed-plate of the machine; A¹, cone driving-pulleys on shaft A²; A³,

bevel-gear on said shaft for transmitting motion from a bevel-gear A⁴ to the vertical shaft A⁵, journaled centrally within the column. A⁶ represents the base of the column.

A⁷ is a clamping-yoke, forming the lower journal-bearing for the revolving tubular column on which the radial drill-arm B journals. These parts may be of the usual construction.

Motion is transmitted to raise and lower the drill-arm and to revolve the tubular column on which it is journaled and to drive the drill-spindle from the interior vertical shaft A⁵ in the following manner: On the top of the column are mounted two series of transmitting-gears. Affixed to vertical shaft A⁵ are gears 1 and 2. Gear 2 drives gear 3, mounted on stud-shaft A⁶. This gear transmits motion to gear 4 on the shaft 7, which transmits power from reversing-gears, hereinafter described, to the radial-arm shaft L.

In order to transmit variable speed to the screw-shaft, I provide the following driving devices: C represents a tumbler-arm mounted on the screw-shaft D. Said tumbler-shaft carries a gear 6 always in mesh with gear 5. Said tumbler-arm is provided with rack-teeth 9, engaging with segment-gear 10, so as to shift the same. When shifted to the right, gear 6 is brought into mesh with gear 1, and gear 5 is driven in one direction to raise the radial arm at slow speed. When it is desired to lower the arm, the tumbler-arm C is moved to the left, bringing said gear 6 into mesh with gear 14, and motion is transmitted by gears 2 and 5 to the stud-shaft on which gear 14 is mounted, which latter in turn transmits power through gear 6 to gear 5, thereby revolving its screw-shaft at a higher rate of speed than the other train of gears and lowers the radial arm at corresponding increased ratio of speed.

It is quite important to be able to reverse the driving motion of the drill-spindle through the main transmitter-shaft and also to be able to stop the motion of the drill-spindle. I have accomplished this result by an improved clutch mechanism which I shall now describe. *b* represents brackets (see Figs. 4 and 10) attached to the cylindrical collar F of the arm B. These brackets carry journal-bearings for the reversing bevel-gears G G', which are preferably provided with a sleeve extension

g. These gear-wheels journal upon clutch-sleeves H H', which are splined upon the shaft 7. These sleeves are provided, preferably, with an enlarged end fitting the interior of the bevel-gear rims, as shown in Fig. 13. This head end of said sleeve is provided with an opening *h*, into which a wedge is forced to spread or enlarge the circumference of the sleeve and cause it to engage rigidly with the inner peripheries of the gears G or G'. In order that the sleeves may be readily thus enlarged, I bore out a circular opening *g'*. I prefer to apply this split-sleeve clutch to the interior of the gear-shell instead of to the sleeve proper, so as to get an increase of frictional area. The gears G G' are normally idle, as shown. They are alternately set in motion by the sliding clutch member K, which carries right and left wedge members *k k'*. When this clutch member is shifted so that wedge *k* is forced into the incline slot *h*, the head of the sleeve is enlarged and clutches firmly the gear G and sets in motion the bevel-gear G², mounted on shaft G³, which carries the transmitting spur-gear G⁴, which transmits motion through speed-changing gears to the horizontal shaft L of the radial arm. This clutch member is shifted by means of the rock-shaft K', which is armed with rack-teeth K², meshing with rack-teeth K³. (See Fig. 10.) The shaft is rocked by means of the lever K⁴. (See Fig. 8.) This may be operated by the ordinary link extension-lever and journaled to the arm, if desired.

In order to change the speed of the radial shaft L, I interpose the following change-speed gears between the gear G⁴ and the shaft L. A plan view of these speed-changing gears is shown in Fig. 9:

M represents the lever of a tumbler-plate which carries a lug adapted to lock in notches *m m'*. It is shown occupying the central position, and shaft L is idle. When moved to engage with notch *m*², gear *m*³ is brought into engagement with gear *m*⁴, which is always in motion, being in mesh with gear *m*⁵ on the same shaft with gear G⁴. When the lever is moved to engage with the notch *m'*, gear *m*⁶ is brought into engagement with gear *m*⁷, which is always in mesh with gear G⁴, which gives a faster motion than the former one to the radial shaft L.

N represents the drill-stock, which is mounted to move on ways of the radial arm B. *n* represents rack-teeth which engage with a pinion *n'*, carried by the shaft N'. N² represents a hand-wheel on said shaft for adjusting the drill-stock laterally on the arm.

The mechanism for driving the drill-spindle is shown in detail, Figs. 5 and 6. 15 represents a bevel-gear on shaft L. Driving bevel-gear 16 is mounted on shaft 17, which also carries bevel-gear 18, meshing with bevel-gear 19, keyed to the drill-spindle O. Gear 15 is feathered on shaft L, so as to allow it to travel longitudinally thereon when the drill-stock is moved laterally.

The power feeding devices are shown in Figs. 4, 5, and 6. 20 represents a bevel-gear keyed to the hub of bevel-gear 19 and driven by bevel-gear 21 on shaft 22. On shaft 22 is mounted a cone of gears 23 24 25, said gears being keyed thereon. These gears mesh, respectively, with gears 26 27 28, which normally run idle on shaft 29. 30 represents a push pin or key which is moved to clutch any one of said gears to the shaft 29, so as to drive the same at different speed, according to which one of the series is clutched, and become the drivers for the rapid or slow raising and lowering of the drill-spindle by power.

The feed motion from shaft 29 to the drill-spindle is imparted in the following manner: 31 represents a worm on said shaft driving worm-wheel 32, mounted on shaft 33, carrying bevel-gear 34, which drives bevel-gear 35. Said bevel-gear 35 carries upon its inner face a spur-gear 36, which meshes with the rack-bar 37, which is rigidly connected to the upper end of the drill-spindle. It is sometimes desirable to raise and lower the drill-spindle by hand. This is accomplished by moving outwardly the screw-shaft 33. The outer bearing 34 is adjustably mounted on the stud-shaft 35, which is journaled loosely in a sufficient distance, which carries shaft 33, swinging on the inner bearing. The spring 41 forces the bearing 34 outwardly when the lever 38 is moved the appropriate direction. Lever 38 is provided with a slot 42, spanning the stud-shaft 35 and locks the said stud-shaft and swiveling on stud 39 and the bearing 34 in position to rigidly hold shaft 33 in its working position. Upon the end of shaft 35 is a hand-wheel 43, which is turned to raise and lower the drill-spindle by hand when the power feed is disengaged.

By the construction and arrangement herein shown the speed-changing devices are mounted upon the column and at the heel of the radial arm, simplifying the construction of the drill-spindle and adjusting-head, as well as cheapening the cost of construction and making a more firm and less complicated tool.

It will thus be seen that the power feeding mechanism of the drill-spindle is variable, that it can readily be unshipped, and the drill fed by hand. By these means the drill is rapidly raised or lowered by either power or hand, and the range of variable speed of the power feeding devices is such that the drill is adapted to do a large variety of work, the speed being readily adapted to any particular work.

Having described my invention, I claim—
1. In a radial drill employing power mechanism for raising and lowering the radial arm, a vertical transmitting-shaft outside of the column, mechanism for driving said shaft, the combination therewith of clutch mechanism mounted upon the cylindrical bearing of the radial arm, right and left hand gears

splined upon the said vertical shaft, an intermediate clutch member splined upon said shaft, and means for moving said clutch member for reversing the motion, a transmitting-shaft carrying a gear in normal engagement with both of the reversing-gears and mounted upon the radial arm, substantially as specified.

2. In a radial drill employing a continuous hollow column, a radial arm mounted thereon, an outside vertical driving-shaft, mechanism for transmitting motion to the same from the top of the column, right and left hand gears mounted on said vertical shaft, a split sleeve splined upon said gears upon which the said gears journal, a sliding clutch member adapted to lock either of said sleeves to the driving-shaft, a transmitting-shaft supported upon the radial arm carrying a transmitting-gear in normal engagement with both of said right and left driving-gears, one or more gears upon said transmitting-shaft meshing with one or more gears upon the radial-arm shaft, and means for operating said gears for controlling the motion of the drill-spindle, substantially as specified.

3. In a radial drill employing a continuous hollow column, a vertical driving-shaft outside of the same, mechanism for driving said shaft, in combination with the reversing-gears, a clutch mechanism mounted upon said shaft, and means for transmitting motion from the said reversing-gears on the vertical shaft to the radial-arm shaft through reversing-gears mounted on said shaft at the heel of said arm, shifting-levers for changing the motion and speed of the radial-arm shaft, substantially as specified.

4. In a radial drill, the combination of a continuous hollow column upon which is mounted a radial-arm support, a vertical driving-shaft outside of the column, right and left hand bevel driving-gears, each journaled upon a sleeve splined to said clutch members splined upon said shaft, a bevel-gear on the intermediate shaft meshing with both of said right and left hand gears and mounted upon and moving with the radial-arm support, two or more driving-gears on said intermediate shaft meshing with speed-changing gears mounted upon the radial-arm shaft journaled upon said radial arm, a lever mechanism for operating a clutch to reverse the motion of the radial-arm shaft, and a lever mechanism for shifting the speed-changing gears, substantially as specified.

5. In a radial drill employing a horizontal driving-shaft engaging with and driving mechanism carried by the drill-stock mounted upon ways moving laterally on said radial arm, a drill-spindle journaled on said stock,

power feeding mechanism consisting of a driving-gear mounted upon and driven by said drill-spindle, a transmitting-gear mounted upon a shaft journaled to said head-stock and carrying a series of gears meshing with a series of gears mounted upon a parallel shaft carrying a hand-wheel, means for clutching any one of said gears with its companion transmitting-gear, a screw-shaft and worm-gear interposed between the said hand-wheel shaft and a rack-bar on the drill-spindle and swiveled upon its inner bearing, the outer end of said screw-shaft being journaled upon a movable bearing and mechanism for throwing the worm-gears out of engagement and for locking them in engagement, substantially as specified.

6. In a radial drill employing a continuous hollow column, an outside vertical driving-shaft receiving motion from a driving-shaft located within the column, right and left hand driving-gears loosely mounted upon the vertical driving-shaft and journaled upon sleeve clutch members, a clutch member splined upon said shaft between said gears, a transmitting-shaft supported upon the radial arm and carrying a gear normally in mesh with both of the driving-gears on the vertical shaft and also employing a transmitting-gear meshing with a gear upon a radial-arm shaft, said driving and transmitting gears being so connected together and supported upon the radial arm that they move up and down in unison therewith, and lever mechanism for reversing the motion of the transmitting-shaft likewise mounted upon the radial arm, substantially as specified.

7. The combination with the continuous hollow column of a radial drill, of an outside driving-shaft, right and left hand sleeve-reversing gears journaled upon sleeve clutch members which are splined upon said vertical shaft, a right and left hand clutch member splined upon said shaft, mechanism for moving it in engagement to lock either of the sleeve clutch members to the reversing-gears, a transmitting bevel-gear meshing with both of said reversing bevel-gears and mounted upon a transmitting-shaft supported upon the radial arm, and means for conveying motion to a shaft upon the radial arm, the said gears and transmitting-shaft being so connected to each other and to the radial arm that they move up and down in unison with the said radial arm, substantially as specified.

In testimony whereof I have hereunto set my hand.

ANTON MILL.

Witnesses:

OLIVER B. KAISER,
EMMA MILL.