

(12) PATENT
(19) AUSTRALIAN PATENT OFFICE

(11) Application No. AU 199656907 B2
(10) Patent No. 724544

(54) Title
Nail for maintaining the location and shape of broken long bones

(51)⁶ International Patent Classification(s)
A61B 017/72 A61F 002/36

(21) Application No: 199656907 (22) Application Date: 1996.04.19

(87) WIPO No: W096/32899

(30) Priority Data

(31) Number	(32) Date	(33) Country
19514758	1995.04.21	DE

(43) Publication Date : 1996.11.07
(43) Publication Journal Date : 1997.01.02
(44) Accepted Journal Date : 2000.09.28

(71) Applicant(s)
Gerd Werding; Willi Schneider

(72) Inventor(s)
Gerd Werding; Willi Schneider

(74) Agent/Attorney
FREEHILLS CARTER SMITH and BEADLE,Level 47,101 Collins Street,MELBOURNE
VIC 3000

(56) Related Art
US 5376123
US 5102413
FR 2629337

OPI DATE 07/11/96 APPLN. ID 56907/96
 AOJP DATE 02/01/97 PCT NUMBER PCT/EP96/01652



AU9656907

<p>(51) Internationale Patentklassifikation⁶: A61B 17/72, A61F 2/36</p>	<p>A1</p>	<p>(11) Internationale Veröffentlichungsnummer: WO 96/32899 (43) Internationales Veröffentlichungsdatum: 24. Oktober 1996 (24.10.96)</p>
<p>(21) Internationales Aktenzeichen: PCT/EP96/01652 (22) Internationales Anmeldedatum: 19. April 1996 (19.04.96) (30) Prioritätsdaten: 195 14 758.8 21. April 1995 (21.04.95) DE (71)(72) Anmelder und Erfinder: WERDING, Gerd [DE/DE]; Theresienstrasse 29, D-85049 Ingolstadt (DE). SCHNEIDER, Willi [DE/DE]; Neuburger Strasse 60, D-85049 Ingolstadt (DE). (74) Anwalt: WILHELMS, KILIAN & PARTNER; Eduard- Schmid-Strasse 2, D-81541 München (DE).</p>	<p>(81) Bestimmungsstaaten: AU, BR, CA, CN, CZ, HU, JP, KR, LT, LV, NO, PL, RU, SI, SK, TR, US, europäisches Patent (AT, BE, CH, DE, DK, ES, FI, FR, GB, GR, IE, IT, LU, MC, NL, PT, SE). Veröffentlicht <i>Mit internationalem Recherchenbericht. Vor Ablauf der für Änderungen der Ansprüche zugelassenen Frist. Veröffentlichung wird wiederholt falls Änderungen eintreffen.</i></p>	

(54) Title: NAIL FOR MAINTAINING THE LOCATION AND SHAPE OF BROKEN LONG BONES

(54) Bezeichnung: NAGEL ZUR LAGE- UND FORMFIXIERUNG VON GEBROCHENEN RÖHRENKNOCHEN

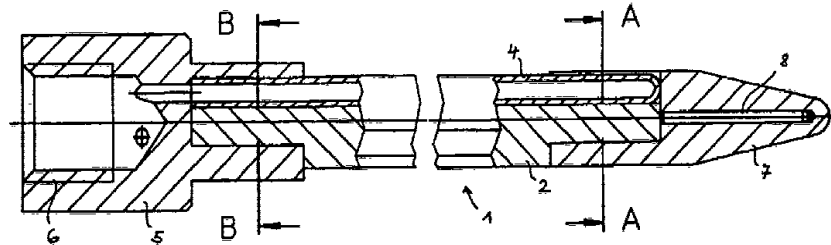

(57) Abstract

The invention concerns a nail designed to maintain the location and shape of broken long bones, the nail having a shank (1) with, running along its length, one or more expansion chambers (4) in which the pressure can be increased using a liquid or gas so that the chambers expand radially outwards.

(57) Zusammenfassung

Gegenstand der Erfindung ist ein Nagel zur Lage- und Form-fixierung von gebrochenen Röhrenknochen, wobei der Nagel einen Schaft (1) mit einem oder mehreren sich über seine Länge erstreckenden kammerförmigen Vergrößerungskörpern (4) aufweist, die durch Flüssigkeit oder Gas von innen unter radialer Aufweitung derselben unter Druck setzbar sind.

NAIL FOR FIXING THE POSITION AND SHAPE OF BROKEN LONG BONES

Description

The invention relates to a nail for fixing the position and shape of broken long bones.

5 Up until now, relatively large steel nails having a predominantly U-shaped or V-shaped cross section have been used for internally stabilising broken long bones. The nails stabilise the bones according to the principle of providing support at three points, namely at the beginning, at the end and in the mid-section of the nail. In order to position such nails, large passages matching the diameter of the implanted
 10 nail must be cut through the surface of the bone and then through the medullary cavity of the bone. This has the disadvantage that almost all of the medullary cavity has to be reamed out in order to produce such a passage, and as a result in particular the blood supply of the bone is impaired. In addition, because of the three-point support, the force is transmitted via a relatively small area, and to ensure rotational
 15 stability it is necessary to use additional mechanisms such as locking screws and the like.

Removing the intramedullary nail after the bone has healed is also a procedure requiring a relatively high degree of effort. The nail is wedged in the medullary cavity and must be knocked out of the cavity using special tools and
 20 applying a relatively large amount of force. Again, considerable damage may be sustained by the medullary cavity in the process.

DE-C-32 01 056 describes an intramedullary nail according to the invention there is provided a nail for fixing the position and shape of broken long bones, said nail possessing a shank having a central main section and possessing a chamber-like
 25 expansion element attached to and extending over the length of the main section, and said expansion element can be internally pressurised in situ and caused to expand radially by means of a gas or liquid, characterised in that several expansion elements are arranged around and extend over the length of the main section. In that nail, the shank consists of a hollow body made of a memory alloy which can
 30 assume two possible shapes, as a function of temperature. Thus, when in situ, the intramedullary nail can be transformed from having a small cross section to having



an expanded cross section, and vice versa. The disadvantage of this prior art type of intramedullary nail is that the application of heat required to expand the diameter of the shank of the nail also causes thermal stress in the bone and the bone marrow.

5 An object of the invention is to create a nail for fixing the position and shape of the broken long bones which provides good stabilisation and can be implanted without causing large-scale damage to the medullary cavity, and which also does not place any thermal stress at all on the bone and bone marrow.

10 According to the present invention, the nail in the non-expanded state, i.e. while it still has a small diameter, can be inserted through a relatively small cortical channel into the medullary cavity. It is not necessary to ream out the medullary cavity, thereby damaging large sections of it. When the nail is fully implanted, its cross section is expanded, without the application of heat, to the extent required in order to stabilise the broken bone. The supporting forces are then distributed over a large area. Rotational stability is also achieved through the surface contact and the resulting adaptation to the given shape of the medullary cavity.

15 In a preferred form the expansion element or elements can be returned to the non-expanded state while in situ.

20 Since the cross sectional enlargement is reversible, the implant may be removed in a manner that is particularly protective of the tissue, once the bone has healed.

Further advantageous embodiments of the invention are the subject of the other sub-claims.

25 In another aspect of the invention there is provided a nail for fixing the position and shape of broken long bones, said nail comprising a shank having a chamber-like expansion element extending along the longitudinal axis of the shank and being inflatable and radially expandable in cross section, while in situ, by introduction of fluid into said expansion element, said expansion element comprising ribs extending along said longitudinal axis and radially outward from said expansion element.

30 Preferred embodiments of the invention will now be described on the basis of the attached drawings, which show:



Fig. 1 an embodiment of the nail according to the invention, seen here in longitudinal section,

Fig. 2 a cross section along the line B-B in Fig. 1,

Fig. 3 a cross section along the line A-A in Fig. 1,

5 Fig. 4 another cross section along line A-A with the expansion elements retracted and expanded,

Fig. 5 a cross section, corresponding to that in Fig. 4, of another embodiment of the main section of the shank and of the expansion elements,

10 Fig. 6 a cross section, corresponding to that in Fig. 4 of another embodiment of the main section of the shank and of the expansion elements,

Fig. 7 a cross section, corresponding to that in Fig. 4, of an embodiment having a central expansion element with radially projecting stiffening ribs running in an axial direction attached around the periphery,

15 Fig. 8 a cross section, corresponding to that in Fig. 4, of an embodiment similar to that in Fig. 7 having stiffening ribs integrally formed with the central expansion element in a configuration similar to that in Fig. 7,

Fig. 9 a cross section, corresponding to that in Fig. 4, of an embodiment with an expansion element folded on itself in the non-expanded state,

20 Fig. 10 an embodiment of a valve, seen in longitudinal section, used in the head of the nail shown in Fig. 1,

Fig. 11 a view, corresponding to that in Fig. 10, of an embodiment in which the head of the nail is designed as part of the valve,

Fig. 12 an embodiment similar to that in Fig. 11, having a sphere instead of a piston as the sealing body,

25 Fig. 13 an embodiment having a perforable membrane instead of the valve,

Fig. 14 a diagonal view of the nail from Fig. 1,

Figs. 15a and 15b an embodiment of a nail according to the invention seen in longitudinal section and partial lateral view, respectively, with a screw tip, and

30 Figs. 16a and 16b a lateral view and a front view, seen from the tip, of a nail having extendable elements in the tip.

The nail for long bones, as illustrated in Fig. 1, possesses a shank 1 having a



main section 2 made preferably of tissue-compatible plastic. This main section 2 is essentially dimensionally stable, but preferably possesses a certain amount of flexural elasticity. In the embodiment shown here it is circular in cross section and is provided with three grooves 3 running longitudinally and arranged at intervals of 120° around the periphery. In these grooves are mounted tubular expansion elements 4, also preferably made of tissue-compatible plastic, which are preferably elastically expandable in cross section. In the unpressurised resting state, the expansion elements 4 preferably do not extend beyond the outer contour of the main section 2. The head 5 of the nail is formed as the connector for a filling and discharging valve, as shown in Fig. 10, and it is provided with a corresponding connecting thread 6 for the valve. At the tip of the nail is located an end cap 7 which is preferably conically shaped to facilitate insertion of the nail. The tip contains preferably a metal pin 8 which is visible under X-ray monitoring, thus facilitating the insertion of the nail. It is also conceivable to use a metal strip extending over the entire length of the nail.

When the expansion elements 4, each of which has the form of a chamber, are pressurised internally by pumping in a gas or a fluid - physiological saline solution is ideal from the medical standpoint - they expand as shown in Fig. 4, so that the cross section of the shank 1 of the nail is enlarged overall. An approximately star-shaped structure when seen in cross sectional view is formed. The parts extending farthest outwards fill only a fraction of the circumscribed cross section, so that sufficient space is left into which the bone marrow can be displaced. The type and size of the contact area with the bone can be influenced by approximately shaping the cross section of the expansion elements. The flexural elasticity of the main section 2, and thus of the shank 1 in general, allows the shank also to follow curvatures in the medullary cavity and, together with the nature of the expansion elements, ensures uniform contact with the bone in a lengthwise direction.

Fig. 5 shows an embodiment in which the chamber-like expansion elements have the form not of elastic elements but of folded elements which lie in the, in this case, concave grooves 3 when not pressurised.



Fig. 6 shows an embodiment in which expansion elements are folded when they are not pressurised and expand to form shapes of triangular cross section with rounded tips.

Figs. 7 to 9 show embodiment of the nail shank 1 in which a central main section of the kind referred to above is not present. Instead, the central element is formed by an expandable or, in the unpressurised state, a folded, tubular expansion element 4 around the periphery of which, and integrally formed therewith or attached thereto are arranged ribs 10 extending axially and projecting radially, said ribs being dimensionally stable and having a desired amount of flexural elasticity.

When the expansion element 4 is unpressurised, the ribs 10 are arranged close together and define a shank of small cross section. When the expansion element 4 is inflated with gas or liquid, in particular with physiological saline solution, the cross sectionally enlarged expansion element 4 defines the cross section of the shank of the nail, and attached ribs 10, which are the elements in contact with the bone, continue to provide the stiffness of the nail shank.

In order to expand the nail shank, for example, a valve fitted in the head 5 of the nail is used, as shown in Fig. 10. In the embodiments illustrated in Figs. 11 and 12, the nail head 5 is designed in such a manner that it is itself part of the valve. The same valve is also used to release the pressure in the expansion element or elements 4, i.e. to discharge the expansion medium with which said element or elements have been filled.

In an especially advantageous embodiment of the invention, as illustrated in Fig. 13, the nail head 5 contains merely a perforable membrane 12 for a canula 14 by means of which a liquid can be pumped in to fill the expansion elements. Once they have been expanded, the canula 14 is withdrawn and the perforable membrane 13 seals itself automatically. To drain off the expansion liquid once the healing process is complete, the canula is again inserted through the membrane and the liquid is drawn off once more.

Fig. 14 shows a diagonal view of the nail which is seen in longitudinal section Fig. 1. The nail has a typical length of between 25 and 35 cm corresponding to the length of the femur.



Figs. 15a and 15b show an embodiment of the nail having a threaded tip 16 which permits special anchoring of the nail in the bone, as do also the strut arrangement 18 shown in the embodiment illustrated in Figs. 16a and 16b.

In a preferred design, the nail is made from a material that can be resorbed
5 by the body. This makes it unnecessary to remove the nail once healing is complete.

5
6
7
8
9
10



DCC:BGC:TG:40313053.RS2

26 July 2000

The claims defining the invention are as follows:

1. A nail for fixing the position and shape of broken long bones, said nail possessing a shank (1) having a central main section (2) and possessing a chamber-like expansion element (4) attached to and extending over the length of the main section, and said expansion element can be internally pressurised in situ and caused to expand radially by means of a gas or liquid, characterised in that several expansion elements (4) are arranged around and extend over the length of the main section (2).
2. A nail according to Claim 1, characterised in that the expansion element or elements (4) can be returned to the non-expanded state while in situ.
3. A nail according to Claim 1 and 2, characterised in that the nail possesses at its head end a valve for introducing and discharging a fluid or gas, thereby expanding or reducing the cross sectional dimension of the nail shank.
4. A nail according to Claim 1 or 2, characterised in that the nail possesses at its head end a perforable membrane (12) for inserting a canula (14) to introduce a discharge a fluid or gas.
5. A nail according to one of the foregoing Claims, characterised in that the nail possesses a screw tip (16).
6. A nail according to one of the Claims 1 to 4, characterised in that the nail possesses a tip with a strut arrangement (18).
7. A nail for fixing the position and shape of broken long bones, said nail comprising a shank having a chamber-like expansion element extending along the longitudinal axis of the shank and being inflatable and radially expandable in cross section, while in situ, by introduction of fluid into said expansion element, said expansion element comprising ribs extending along said longitudinal axis and radially outward from said expansion element.
8. A nail for fixing the position and shape of broken long bones substantially as hereinbefore described with reference to the accompanying drawings.

DATED: 26 July 2000

Freehills Carter Smith Beadle
 Patent Attorneys for the Applicant:
Gerd Werding and Willi Schneider



DCC:BGC:TG:40313053.RS2

26 July 2000

200 85005

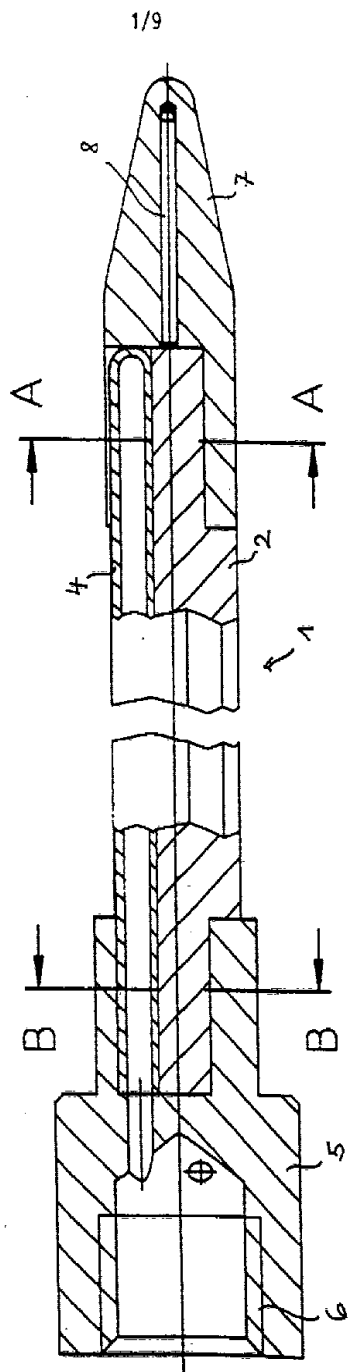

Fig. 1

26 700 35307

B - B

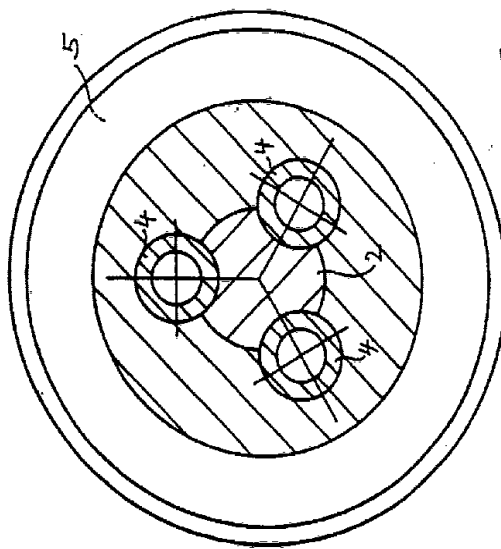

Fig. 2

A - A

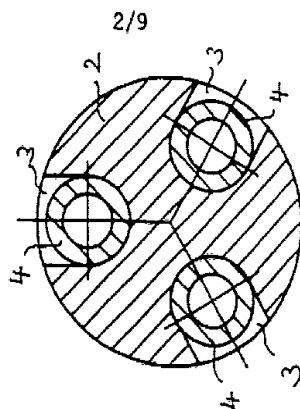

Fig. 3

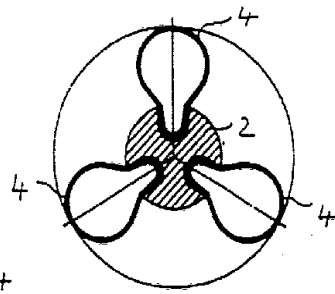
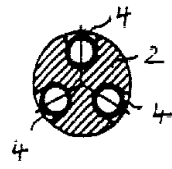

Fig. 4

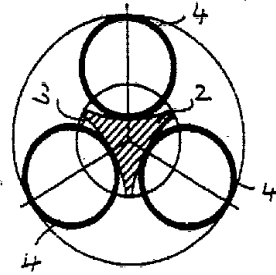
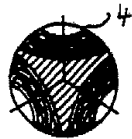

Fig. 5

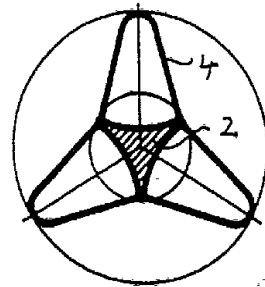

Fig. 6

505
700
8

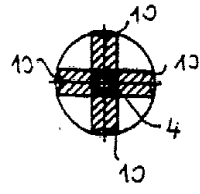

Fig. 7

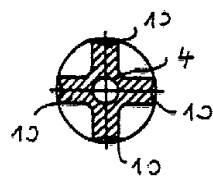
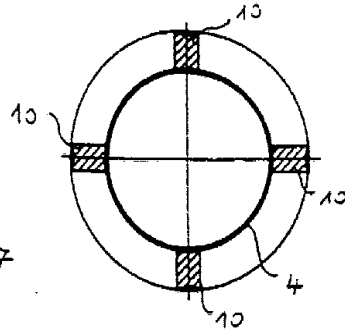

Fig. 8

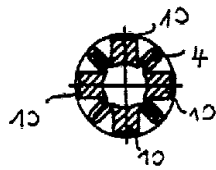
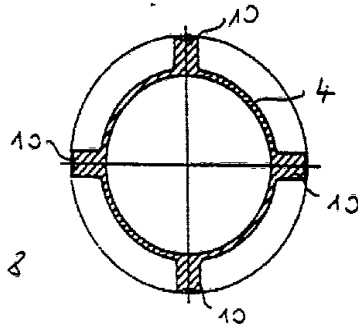
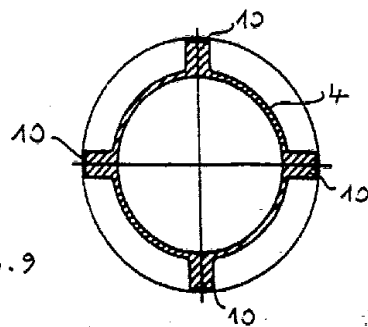

Fig. 9



5
6
7
8
9

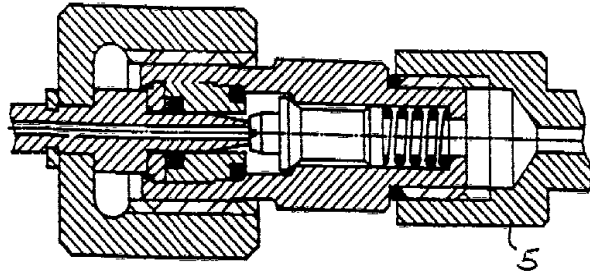

Fig. 10

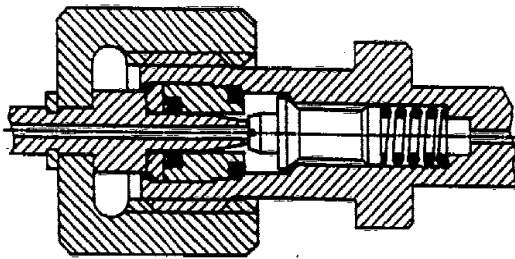

Fig. 11

5
5
2
8

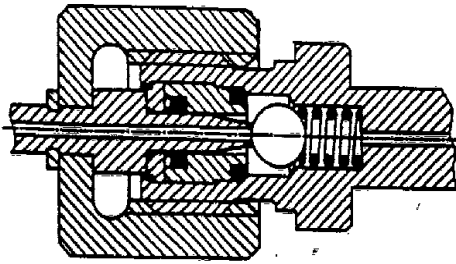

Fig. 12

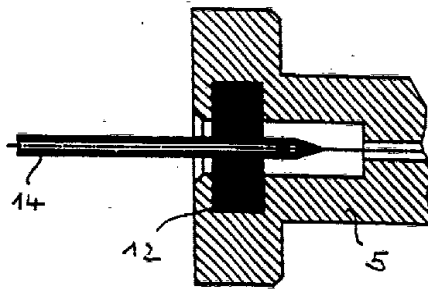

Fig. 13

5
2
3

35 700 35007

7/9

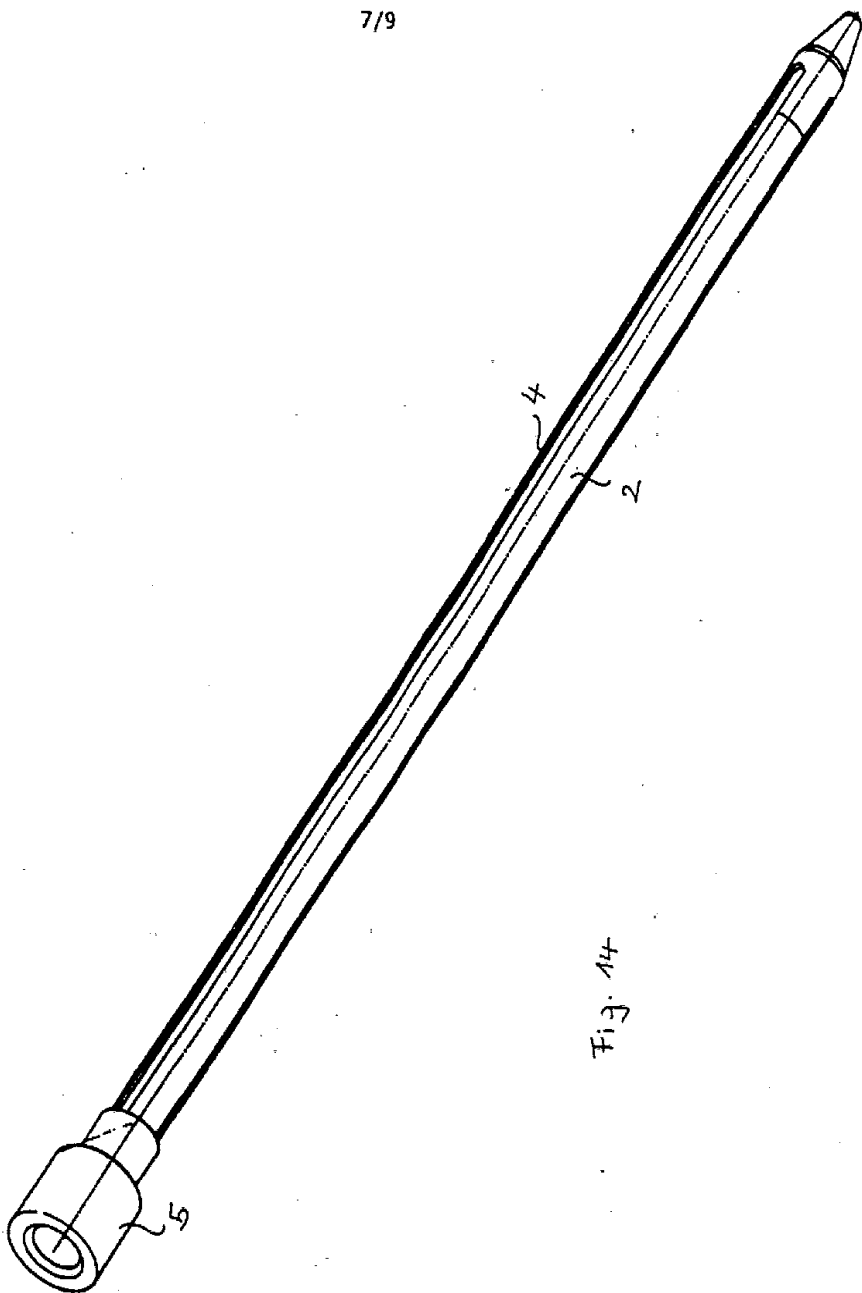

Fig. 14

39 700 58007

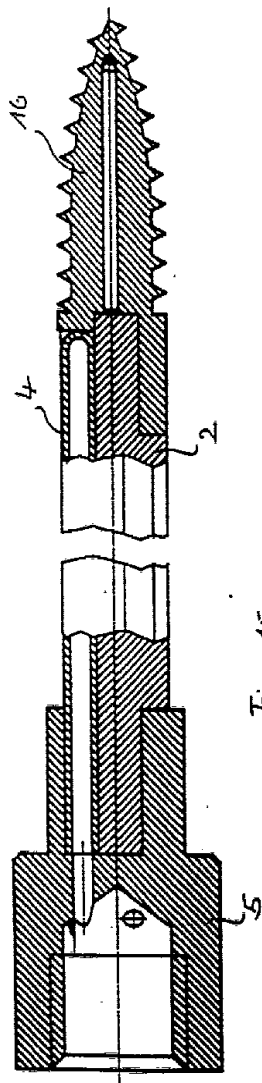

Fig. 15a

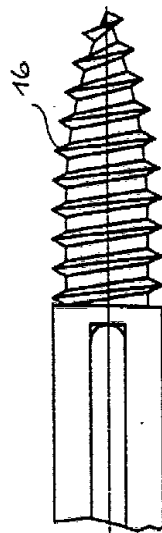

Fig. 15b

39 709 28007

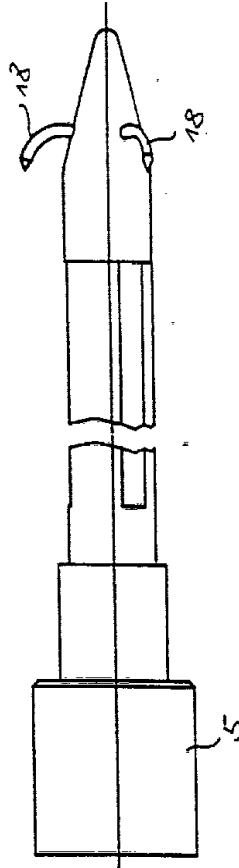

Fig. 16a

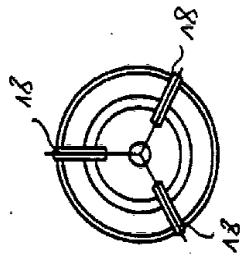

Fig. 16b