

(19) **DANMARK**

(10) **DK/EP 3764961 T3**



(12) **Oversættelse af  
europæisk patentskrift**

Patent- og  
Varemærkestyrelsen

- 
- (51) Int.Cl.: **A 61 F 5/445 (2006.01)** **A 61 B 5/00 (2006.01)** **A 61 F 5/44 (2006.01)**  
**A 61 F 5/443 (2006.01)**
- (45) Oversættelsen bekendtgjort den: **2024-04-22**
- (80) Dato for Den Europæiske Patentmyndigheds bekendtgørelse om meddelelse af patentet: **2024-02-21**
- (86) Europæisk ansøgning nr.: **19713693.0**
- (86) Europæisk indleveringsdag: **2019-03-15**
- (87) Den europæiske ansøgnings publiceringsdag: **2021-01-20**
- (86) International ansøgning nr.: **DK2019050091**
- (87) Internationalt publikationsnr.: **WO2019174697**
- (30) Prioritet: **2018-03-15 DK PA201870165**
- (84) Designerede stater: **AL AT BE BG CH CY CZ DE DK EE ES FI FR GB GR HR HU IE IS IT LI LT LU LV MC MK MT NL NO PL PT RO RS SE SI SK SM TR**
- (73) Patenthaver: **COLOPLAST A/S, Holtedam 1, 3050 Humlebæk, Danmark**
- (72) Opfinder: **SVANEGAARD, Mads Hindhede, Peder Hesselsvej 38, 2880 Bagsværd, Danmark**  
**Stroebech, Esben, Selmersvej 11, 2970 Hørsholm, Danmark**  
**EISENBERG, Jacob, Skovbo Allé 68, 2670 Greve, Danmark**  
**OLSEN, Carsten Hllum, Nyelandsvej 83, 3.tv., 2000 Frederiksberg, Danmark**  
**MALMBERG, Jeppe, Toendergade 22, 1752 København V, Danmark**  
**POULSEN, Alex, Birkegaarden 17, 3500 Værløse, Danmark**
- (74) Fuldmægtig i Danmark: **RWS Group, Europa House, Chiltern Park, Chiltern Hill, Chalfont St Peter, Bucks SL9 9FG, Storbritannien**
- (54) Benævnelse: **APPARAT OG FREMGANGSMÅDER TIL AT NAVIGERE EN BRUGER AF ET STOMIAPPARAT TIL ET OMKLÆDNINGSRUM**
- (56) Fremdragne publikationer:  
**US-A1- 2004 100 376**  
**US-A1- 2013 324 952**  
**US-A1- 2017 140 103**  
**US-A1- 2017 340 474**  
**US-B1- 6 171 289**



# DESCRIPTION

## Description

**[0001]** The present disclosure relates to an ostomy system, devices thereof, method of manufacturing and method for monitoring an ostomy appliance. The ostomy appliance system comprises an ostomy appliance and an ostomy monitor device. In particular, the present disclosure relates to navigating an ostomy appliance user to one or more changing rooms for replacing at least a portion of the ostomy appliance.

## Brief Description of the Drawings

**[0002]** The accompanying drawings are included to provide a further understanding of embodiments and are incorporated into and a part of this specification. The drawings illustrate embodiments and together with the description serve to explain principles of embodiments. Other embodiments and many of the intended advantages of embodiments will be readily appreciated as they become better understood by reference to the following detailed description. The elements of the drawings are not necessarily to scale relative to each other. Like reference numerals designate corresponding similar parts.

Fig. 1 illustrates an exemplary ostomy system,

Fig. 2 illustrates an exemplary monitor device of the ostomy system,

Fig. 3 is an exploded view of a base plate of an ostomy appliance,

Fig. 4 is an exploded view of an exemplary electrode assembly,

Fig. 5 is a proximal view of parts of a base plate,

Fig. 6 is a distal view of an exemplary electrode configuration,

Fig. 7 is a distal view of an exemplary masking element,

Fig. 8 is a distal view of an exemplary first adhesive layer,

Fig. 9 is a proximal view of the first adhesive layer of Fig. 8,

Fig. 10 is a distal view of a part of the base plate including monitor interface,

Fig. 11 illustrates an exemplary accessory device in connection with the ostomy appliance for performing various functions,

Fig. 12 illustrates a one-part ostomy appliance being applied to a stoma of a user,

Fig. 13 illustrates a two-part ostomy appliance being applied to the stoma of the user,

Fig. 14 illustrates the accessory device of Fig. 11 used in connection with the ostomy appliance,

Fig. 15 is an exemplary screen of the accessory device of Fig. 11 depicting configuration criteria,

Fig. 16 is an exemplary screen of the accessory device of Fig. 11 depicting calendar data,

Fig. 17 is an exemplary screen of the accessory device of Fig. 11 depicting additional configuration criteria,

Fig. 18 is an exemplary screen of the accessory device of Fig. 11 depicting selection results, and

Fig. 19 is a flowchart illustrating an exemplary method of selecting one or more changing rooms using the accessory device of Fig. 11.

Fig. 20 is an exemplary graphical representation of parameter data as a function of time,

Fig. 21 is an exemplary graphical representation of parameter data as a function of time,

Fig. 22 is an exemplary graphical representation of parameter data as a function of time,

Fig. 23 is an exemplary graphical representation of parameter data as a function of time and a whitening zone diameter as a function of time,

Figs. 24A-24B are exemplary graphical representations of peel force as a function of a peeling distance travelled by a peeling action exercising the peel force on a first adhesive layer of a base plate.

Figs. 25A-25B are exemplary graphical representations of a whitening zone diameter,

Fig. 26A is an exemplary graphical representation of first parameter data as a function of time for various semi-solid matter scenarios,

Fig. 26B is an exemplary graphical representation of first parameter data as a function of percentage of semi-solid matter in the mixture applied to the stomal opening,

Figs. 27A-27B are exemplary graphical representations of parameter data as functions of time for different predetermined temperatures.

## **Background**

**[0003]** The prior art includes US2013/324952A1, which relates to a method relating to use and performance of ostomy appliances by providing one or more sensors to an ostomy pouch. The method includes collecting sensor data, comparing sensor data to historical sensor data, and predicting in advance of a failure of the ostomy pouch, a reduction in nominal wear time.

**[0004]** Further, the prior art includes US2017/340474A1, which relates to a method and dressing for detecting detachment of the dressing, which is applied to a surface of an at least partly electrically conductive object. The dressing comprises an adhesive and at least two electrodes arranged in a distance from the electrically conductive object. Changes in capacitance are detected, and an alarm is activated when the changes of the capacitance reach a predetermined value.

**[0005]** Further, the prior art includes US2017/140103A1, which relates to systems and methods for providing comprehensive care for stoma patients. The system includes a sensor device for detecting a fill level of an ostomy bag fitted over and around a stoma and is configured to sense one or more parameters of an effluent received in the bag and to communicate the measurements to a stoma care management software application.

**[0006]** Further, the prior art includes US6171289B1, which relates to a disposable device for securing an ostomy bag to a stoma, the device comprising an adhesive seal and means for detecting wetness of the adhesive composition and means for triggering an alarm when a predetermined level of wetness is reached in the adhesive.

**[0007]** Further, the prior art includes US2004/100376A1, which relates to a wireless health care monitor system and method. A UWB biosensor transmitter is assigned to an individual to be remotely monitored. The biosensor transmitter includes a biosensor disposed to detect a health condition of the user and generate a corresponding biosensor reading.

### **Detailed Description**

**[0008]** Various exemplary embodiments and details are described hereinafter, with reference to the figures when relevant. It should be noted that the figures may or may not be drawn to scale and that elements of similar structures or functions are represented by like reference numerals throughout the figures. It should also be noted that the figures are only intended to facilitate the description of the embodiments. They are not intended as an exhaustive description of the invention or as a limitation on the scope of the invention. In addition, an illustrated embodiment needs not have all the aspects or advantages shown. An aspect or an advantage described in conjunction with a particular embodiment is not necessarily limited to that embodiment and can be practiced in any other embodiments even if not so illustrated, or if not so explicitly described.

**[0009]** Throughout this disclosure, the words "stoma" and "ostomy" are used to denote a surgically created opening bypassing the intestines or urinary tract system of a person. The

words are used interchangeably, and no differentiated meaning is intended. The same applies for any words or phrases derived from these, e.g. "stomal", "ostomies" etc. Also, the solid and liquid wastes emanating from the stoma may be referred to as both stomal "output," "waste(s)," and "fluids" interchangeably. A subject having undergone ostomy surgery may be referred to as "ostomist" or "ostomate" - moreover, also as "patient" or "user". However, in some cases "user" may also relate or refer to a health care professional (HCP), such as a surgeon or an ostomy care nurse or others. In those cases, it will either be explicitly stated, or be implicit from the context that the "user" is not the "patient" him- or herself.

**[0010]** In the following, whenever referring to proximal side or surface of a layer, an element, a device or part of a device, the referral is to the skin-facing side or surface, when a user wears the ostomy appliance/monitor device. Likewise, whenever referring to the distal side or surface of a layer, an element, a device or part of a device, the referral is to the side or surface facing away from the skin, when a user wears the ostomy appliance/monitor device. In other words, the proximal side or surface is the side or surface closest to the user, when the appliance is fitted on a user and the distal side is the opposite side or surface - the side or surface furthest away from the user in use.

**[0011]** An axial direction is defined as the direction of the stoma, when a user wears the appliance. Thus, the axial direction is generally perpendicular to the skin or abdominal surface of the user.

**[0012]** The radial direction is defined as perpendicular to the axial direction. In some sentences, the words "inner" and "outer" may be used. These qualifiers should generally be perceived with respect to the radial direction, such that a reference to an "outer" element means that the element is farther away from a centre portion of the ostomy appliance than an element referenced as "inner". In addition, "innermost" should be interpreted as the portion of a component forming a centre of the component and/or being adjacent to the centre of the component. In analogy, "outermost" should be interpreted as a portion of a component forming an outer edge or outer contour of a component and/or being adjacent to that outer edge or outer contour.

**[0013]** The use of the word "substantially" as a qualifier to certain features or effects in this disclosure is intended to simply mean that any deviations are within tolerances that would normally be expected by the skilled person in the relevant field.

**[0014]** The use of the word "generally" as a qualifier to certain features or effects in this disclosure is intended to simply mean - for a structural feature: that a majority or major portion of such feature exhibits the characteristic in question, and - for a functional feature or an effect: that a majority of outcomes involving the characteristic provide the effect, but that exceptionally outcomes do not provide the effect.

**[0015]** The present disclosure relates to an ostomy system and devices thereof, such as an ostomy appliance, a base plate for an ostomy appliance, a monitor device, and optionally one

or more accessory devices. Further, methods related to the ostomy system and devices thereof are disclosed. An accessory device (also referred to as an external device) may be a mobile phone or other handheld device. An accessory device may be a personal electronic device, e.g. a wearable, such as a watch or other wrist-worn electronic device. An accessory device may be a docking station. The docking station may be configured to electrically and/or mechanically couple the monitor device to the docking station. The docking station may be configured for charging the monitor device and/or configured for transferring data between the monitor device and the docking station. The ostomy system may comprise a server device. The server device may be operated and/or controlled by the ostomy appliance manufacturer and/or a service centre.

**[0016]** An ostomy system comprising an ostomy appliance and a monitor device, the ostomy appliance comprising a base plate is disclosed, wherein the monitor device is a monitor device as described herein.

**[0017]** An ostomy system comprising a monitor device and an ostomy appliance comprising a base plate is disclosed, the base plate having a first adhesive layer with a proximal side configured for attachment of the base plate to the skin surface of a user, the first adhesive layer having a stomal opening with a center point, the monitor device comprising a processor and a sensor unit comprising a first sensor with a first sensor surface accommodated in a monitor device housing, the monitor device housing having a sensor opening in a proximal surface of the monitor device, the sensor opening forming at least a part of a sensor path from surroundings of the proximal surface to the first sensor surface.

**[0018]** Also disclosed is a monitor device for an ostomy appliance of an ostomy system, the monitor device comprising a processor and a sensor unit comprising a first sensor with a first sensor surface accommodated in a monitor device housing, the monitor device housing having a sensor opening in a proximal surface of the monitor device, the proximal surface configured for facing the skin of a user during use, the sensor opening forming at least a part of a sensor path from surroundings of the proximal surface to the first sensor surface.

**[0019]** The present disclosure provides an ostomy system and devices thereof, such as an ostomy appliance, a base plate for an ostomy appliance, a monitor device, and optionally one or more accessory devices which either alone or together facilitate reliable determination of the nature, severity and rapidness of moisture propagation in the adhesive material provided for attaching the base plate to the skin surface of a user. Depending on the nature of the pattern of moisture propagation in the adhesive, the ostomy system and devices thereof enable providing information to the user about the type of failure, and in turn enable providing an indication to the user of the severity and thus the remaining time frame for replacing the ostomy appliance without experiencing severe leakage and/or skin damage.

**[0020]** The ostomy appliance comprises a base plate and an ostomy pouch (also referred to as an ostomy bag). The ostomy appliance may be a colostomy appliance, an ileostomy appliance or a urostomy appliance. The ostomy appliance may be a two-part ostomy

appliance, i.e. the base plate and the ostomy pouch may be releasably coupled e.g. with a mechanical and/or an adhesive coupling, e.g. to allow that a plurality of ostomy pouches can be utilized (exchanged) with one base plate. Further, a two-part ostomy appliance may facilitate correct application of the base plate to skin, e.g. due to an improved user sight of the stomal region. The ostomy appliance may be a one-part ostomy appliance, i.e. the base plate and the ostomy pouch may be fixedly attached to each other. The base plate is configured for coupling to a user's stoma and/or skin surrounding the stoma, such as a peristomal skin area.

**[0021]** A base plate for an ostomy appliance is disclosed, the base plate comprising a first adhesive layer with a proximal side configured for attachment of the base plate to the skin surface of a user, the first adhesive layer having a stomal opening with a center point; and a plurality of electrodes including a ground electrode, a first electrode, and an optionally a second electrode, the ground electrode comprising a ground connection part, the first electrode comprising a first connection part, and the second electrode comprising a second connection part, wherein the ground electrode forms a ground for the first electrode and/or the second electrode.

**[0022]** The base plate comprises a first adhesive layer. During use, the first adhesive layer adheres to the user's skin (peristomal area) and/or to additional seals, such as sealing paste, sealing tape and/or sealing ring. Thus, the first adhesive layer may be configured for attachment of the base plate to the skin surface of a user. The first adhesive layer may have a stomal opening with a center point or is at least prepared for forming a stomal opening with a center point. A base plate with three electrodes having sensing parts with contact to the first adhesive layer allows for determining erosion/swelling properties or characteristics of the first adhesive layer and/or determining a degree of erosion and/or swelling of the first adhesive layer.

**[0023]** It is an advantage of the present disclosure that an optimum or improved use of an ostomy appliance is provided. In particular, the present disclosure facilitates that a base plate is not changed too early (leading to increased cell-stripping from the skin and increased risk of skin damage and further leading to increased costs and/or material waste) nor too late (leading to adhesive failure, leakage and/or skin damage from the aggressive output). Accordingly, the user or a health care professional is able to monitor and plan the use of the ostomy appliance.

**[0024]** Further, determination of operating state and classification of operating states of the ostomy appliance (e.g., operating state of the base plate) is useful in helping to reduce the risk of a user experiencing leakage from an ostomy appliance. Further, determination of operating state and classification of operating states of the ostomy appliance (e.g., operating states of the base plate) is further useful in helping reduce the risk of skin damage to a user. In particular, determination of operating state according to the present disclosure may help provide a clear distinction or differentiation between adhesive failure, leakage of output, which is harmful to the skin, and a sweating ostomate.

**[0025]** The present disclosure provides a simple, efficient, and easy-to-use ostomy appliance



system with a high degree of comfort for a user.

**[0026]** The first adhesive layer may be made of a first composition. The first composition may comprise one or more polyisobutenes and/or styrene-isoprene-styrene. The first composition may comprise one or more hydrocolloids.

**[0027]** The first composition may be a pressure sensitive adhesive composition suitable for medical purposes comprising a rubbery elastomeric base and one or more water soluble or water swellable hydrocolloids. The first composition may comprise one or more polybutenes, one or more styrene copolymers, one or more hydrocolloids, or any combination thereof. The combination of the adhesive properties of the polybutenes and the absorbing properties of the hydrocolloids renders the first composition suitable for use in ostomy appliances. The styrene copolymer may for example be a styrene-butadienestyrene block copolymer or a styrene-isoprene-styrene block copolymer. Preferably, one or more styrene-isoprene-styrene (SIS) block type copolymers are employed. The amount of styrene block-copolymer may be from 5% to 20% of the total adhesive composition. The butene component is suitably a conjugated butadiene polymer selected from polybutadiene, polyisoprene. The polybutenes are preferably present in an amount of from 35 - 50% of the total adhesive composition. Preferably, the polybutene is polyisobutylene (PIB). Suitable hydrocolloids for incorporation in the first composition are selected from naturally occurring hydrocolloids, semisynthetic hydrocolloids and synthetic hydrocolloids. The first composition may comprise 20-60% hydrocolloids. A preferred hydrocolloid is carboxymethyl cellulose (CMC). The first composition may optionally contain other components, such as fillers, tackifiers, plasticizers, and other additives.

**[0028]** The first adhesive layer may have a plurality of sensor point openings. A sensor point opening of the first adhesive layer is optionally configured to overlap a (sensing) part of an electrode, e.g. to form a sensor point.

**[0029]** The sensor point openings of the first adhesive layer may comprise primary sensor point openings. The primary sensor point openings may comprise one or more primary first sensor point openings and one or more primary second sensor point openings, the primary first sensor point openings configured to overlap (sensing) parts of an electrode and the primary second sensor point openings configured to overlap (sensing) parts of another electrode different from the electrode at least partly overlapped by the primary first sensor point openings.

**[0030]** The sensor point openings of the first adhesive layer may comprise secondary sensor point openings. The secondary sensor point openings may comprise one or more secondary first sensor point openings and one or more secondary second sensor point openings, the secondary first sensor point openings configured to overlap (sensing) parts of an electrode and the secondary second sensor point openings configured to overlap (sensing) parts of another electrode different from the electrode at least partly overlapped by the secondary first sensor point openings.

**[0031]** The sensor point openings of the first adhesive layer may comprise tertiary sensor point openings. The tertiary sensor point openings may comprise one or more tertiary first sensor point openings and one or more tertiary second sensor point openings, the tertiary first sensor point openings configured to overlap (sensing) parts of an electrode and the tertiary second sensor point openings configured to overlap (sensing) parts of another electrode different from the electrode at least partly overlapped by the tertiary first sensor point openings.

**[0032]** The first adhesive layer may have a substantially uniform thickness. The first adhesive layer may have a thickness in the range from 0.1 mm to 1.5 mm, e.g. in the range from 0.2 mm to 1.2 mm, such as 0.8 mm or 1.0 mm.

**[0033]** The first adhesive layer may have a primary thickness in a primary part of the first adhesive layer, e.g. in a primary region within a primary radial distance or in a primary radial distance range from the center point of the stomal opening. The primary thickness may be in the range from 0.2 mm to 1.5 mm, such as about 1.0 mm. The primary radial distance may be in the range from 20 mm to 50 mm, such as in the range from 25 mm to 35 mm, e.g. 30 mm.

**[0034]** The first adhesive layer may have a secondary thickness in a secondary part of the first adhesive layer, e.g. in a secondary region outside a secondary radial distance or in a secondary radial distance range from the center point of the stomal opening. The secondary thickness may be in the range from 0.2 mm to 1.0 mm, such as about 0.5 mm. The secondary radial distance may be in the range from 20 mm to 50 mm, such as in the range from 25 mm to 35 mm, e.g. 30 mm.

**[0035]** The base plate may comprise a second layer. The second layer may be a second adhesive layer, also denoted rim adhesive layer. The second layer may have a second radial extension that is larger than a first radial extension of the first adhesive layer at least in a first angular range of the base plate. Accordingly, a part of a proximal surface of the second layer may be configured for attachment to the skin surface of a user. The part of a proximal surface of the second layer configured for attachment to the skin surface of a user is also denoted the skin attachment surface of the second adhesive layer. The second layer may have a stomal opening with a center point.

**[0036]** The second adhesive layer may be made of a second composition. The second composition may comprise one or more polyisobutenes and/or styrene-isoprene-styrene. The second composition may comprise one or more hydrocolloids.

**[0037]** The second composition may be a pressure sensitive adhesive composition suitable for medical purposes comprising a rubbery elastomeric base and one or more water soluble or water swellable hydrocolloids. The second composition may comprise one or more polybutenes, one or more styrene copolymers, one or more hydrocolloids, or any combination thereof. The combination of the adhesive properties of the polybutenes and the absorbing properties of the hydrocolloids renders the second composition suitable for use in ostomy appliances. The styrene copolymer may for example be a styrenebutadiene-styrene block

copolymer or a styrene-isoprene-styrene block copolymer. Preferably, one or more styrene-isoprene-styrene (SIS) block type copolymers are employed. The amount of styrene block-copolymer may be from 5% to 20% of the total adhesive composition. The butene component is suitably a conjugated butadiene polymer selected from polybutadiene, polyisoprene. The polybutenes are preferably present in an amount of from 35 - 50% of the total adhesive composition. Preferably, the polybutene is polyisobutylene (PIB). Suitable hydrocolloids for incorporation in the second composition are selected from naturally occurring hydrocolloids, semisynthetic hydrocolloids and synthetic hydrocolloids. The second composition may comprise 20-60% hydrocolloids. A preferred hydrocolloid is carboxymethyl cellulose (CMC). The second composition may optionally contain other components, such as fillers, tackifiers, plasticizers, and other additives.

**[0038]** Different ratio of contents may change properties of the first and/or second adhesive layers. The second adhesive layer and the first adhesive layer may have different properties. The second adhesive layer (second composition) and the first adhesive layer (first composition) may have different ratios of polyisobutenes, styrene-isoprene-styrene, and/or hydrocolloids. For example, the second adhesive layer may provide a stronger attachment to the skin compared to attachment to the skin provided by the first adhesive layer. Alternatively or additionally, the second adhesive layer may be thinner than the first adhesive layer. Alternatively or additionally, the second adhesive layer may be less water and/or sweat absorbing than the first adhesive layer. Alternatively or additionally, the second adhesive layer may be less moldable than the first adhesive layer. The second adhesive layer may provide a second barrier against leakage.

**[0039]** The second layer may have a substantially uniform thickness. The second layer may have a thickness in the range from 0.1 mm to 1.5 mm, e.g. in the range from 0.2 mm to 1.0 mm, such as 0.5 mm, 0.6 mm, or 0.7 mm.

**[0040]** The base plate comprises one or more electrodes, such as a plurality of electrodes, such as two, three, four, five, six, seven or more electrodes. The electrodes, e.g. some or all the electrodes, may be arranged between the first adhesive layer and the second adhesive layer. The electrodes may be arranged in an electrode assembly, e.g. an electrode layer. An electrode comprises a connection part for connecting the electrodes to other components and/or interface terminals/terminal elements. An electrode may comprise one or more conductor parts and/or one or more sensing parts. The electrode assembly may be arranged between the first adhesive layer and the second adhesive layer. The base plate, e.g. the electrode assembly, may comprise a first electrode, a second electrode and optionally a third electrode. The base plate, e.g. the electrode assembly, may comprise a fourth electrode and/or a fifth electrode. The base plate, e.g. the electrode assembly, optionally comprises a sixth electrode. The base plate, e.g. the electrode assembly, may comprise a ground electrode. The ground electrode may comprise a first electrode part. The first electrode part of the ground electrode may form a ground or reference for the first electrode. The ground electrode may comprise a second electrode part. The second electrode part of the ground electrode may form a ground or reference for the second electrode. The ground electrode may

comprise a third electrode part. The third electrode part of the ground electrode may form a ground or reference for the third electrode. The ground electrode may comprise a fourth electrode part. The fourth electrode part of the ground electrode may form a ground or reference for the fourth electrode and/or the fifth electrode.

**[0041]** The ground electrode or electrode parts of the ground electrode may be configured as or form a (common) reference electrode for some or all of the other electrodes of the electrode assembly. The ground electrode may also be denoted reference electrode.

**[0042]** The electrodes are electrically conductive and may comprise one or more of metallic (e.g. silver, copper, gold, titanium, aluminium, stainless steel), ceramic (e.g. ITO), polymeric (e.g. PEDOT, PANI, PPy), and carbonaceous (e.g. carbon black, carbon nanotube, carbon fibre, graphene, graphite) materials.

**[0043]** The ground electrode may comprise a first electrode part and a second electrode part, the first electrode part forming the ground for the first electrode and the second electrode part forming the ground for the second electrode. The first electrode part may form a closed loop.

**[0044]** The electrodes are electrically conductive and may comprise one or more of metallic (e.g. silver, copper, gold, titanium, aluminium, stainless steel), ceramic (e.g. ITO), polymeric (e.g. PEDOT, PANI, PPy), and carbonaceous (e.g. carbon black, carbon nanotube, carbon fibre, graphene, graphite) materials.

**[0045]** Two electrodes of the electrode assembly may form a sensor. The first electrode and the ground electrode (e.g. first electrode part of the ground electrode) may form a first sensor or first electrode pair. The second electrode and the ground electrode (e.g. second electrode part of the ground electrode) may form a second sensor or second electrode pair. The third electrode and the ground electrode (e.g. third electrode part of the ground electrode) may form a third sensor or third electrode pair. The fourth electrode and the ground electrode (e.g. fourth electrode part of the ground electrode) may form a fourth sensor or fourth electrode pair. The fifth electrode and the ground electrode (e.g. fifth electrode part of the ground electrode) may form a fifth sensor or fifth electrode pair. The fourth electrode and the fifth electrode may form a sixth sensor or sixth electrode pair.

**[0046]** An electrode may comprise a sensing part or a plurality of sensing parts, i.e. the part(s) of an electrode that are used for sensing. The first electrode may comprise a first sensing part. The first sensing part may contact the first adhesive layer and is optionally arranged at least partly annularly around the stomal opening. The first electrode may comprise a first conductor part insulated from the first adhesive layer, e.g. by a masking element arranged between the first conductor part and the first adhesive layer. The first sensing part may extend at least 270 degrees around the stomal opening, such as at least 300 degrees around the stomal opening. The first sensing part of the first electrode may be arranged at a first ground distance from the first electrode part of the ground electrode. The first ground distance may be less than 5 mm, such as less than 3 mm, e.g. about 1.0 mm.

**[0047]** The second electrode may comprise a second sensing part. The second sensing part may contact the first adhesive layer. The second sensing part may be arranged at least partly annularly around the stomal opening. The second sensing part may extend at least 270 degrees around the stomal opening, such as at least 300 degrees around the stomal opening. The second sensing part of the second electrode may be arranged at a second ground distance from the second electrode part of the ground electrode. The second ground distance may be less than 5 mm, such as less than 3 mm, e.g. about 1.0 mm.

**[0048]** The first sensing part may be arranged at a first radial distance from the center point and the second sensing part may be arranged at a second radial distance from the center point. The second radial distance may be larger than the first radial distance. The second electrode may comprise a second conductor part insulated from the first adhesive layer, e.g. by a masking element arranged between the second conductor part and the first adhesive layer. The first radial distance may vary as a function of an angular position with respect to a zero direction from the center point. The second radial distance may vary as a function of an angular position with respect to a zero direction from the center point. The zero direction may be defined as the vertical upward direction when the base plate is in its intended wearing position on an upstanding user.

**[0049]** The first radial distance may be in the range from 5 mm to 40 mm, such as in the range from 10 mm to 25 mm, e.g. about 14 mm. The second radial distance may be in the range from 10 mm to 50 mm, such as in the range from 10 mm to 25 mm, e.g. about 18 mm.

**[0050]** The base plate may comprise a third electrode comprising a third connection part. The ground electrode may form a ground for the third electrode. The ground electrode may comprise a third electrode part, the third electrode part forming the ground for the third electrode. The third electrode may comprise a third conductor part insulated from the first adhesive layer, e.g. by a masking element arranged between the third conductor part and the first adhesive layer. The third electrode may comprise a third sensing part, the third sensing part contacting the first adhesive layer. The third sensing part may be arranged at least partly annularly around the stomal opening. The third sensing part may be arranged at a third radial distance from the center point. The third radial distance may be larger than the first radial distance and/or larger than the second radial distance. The third radial distance may be in the range from 15 mm to 50 mm, such as in the range from 20 mm to 30 mm, e.g. about 26 mm. The third sensing part may extend at least 270 degrees around the stomal opening, such as at least 300 degrees around the stomal opening. The third sensing part of the third electrode may be arranged at a third ground distance from the third electrode part of the ground electrode. The third ground distance may be less than 5 mm, such as less than 3 mm, e.g. about 1.0 mm. A base plate with a ground electrode, a first electrode, a second electrode, and a third electrode allows for a failsafe base plate in case e.g. the first electrode is cut or otherwise destroyed during preparation of the base plate.

**[0051]** The base plate may comprise a fourth electrode comprising a fourth connection part.

The ground electrode may form a ground for the fourth electrode. The ground electrode may comprise a fourth electrode part, the fourth electrode part forming the ground for the fourth electrode. The fourth electrode may comprise one or a plurality of fourth sensing parts, such as at least five fourth sensing parts. The fourth sensing parts may be distributed around the stomal opening or a center point thereof. The fourth sensing parts may be arranged at respective fourth radial distances from the center point. The fourth radial distance(s) may be larger than the third radial distance. The fourth radial distance(s) may be in the range from 25 mm to 50 mm, such as about 30 mm.

**[0052]** The base plate may comprise a fifth electrode comprising a fifth connection part. The ground electrode may form a ground for the fifth electrode. The ground electrode may comprise a fifth electrode part, the fifth electrode part forming the ground for the fifth electrode. The fifth electrode may comprise one or a plurality of fifth sensing parts, such as at least five fifth sensing parts. The fifth sensing parts may be distributed around the stomal opening or a center point thereof. The fifth sensing parts may be arranged at respective fifth radial distances from the center point. The fifth radial distance may be larger than the third radial distance. The fifth radial distance may be equal to or larger than the fourth radial distance. The fifth radial distance(s) may be in the range from 25 mm to 50 mm, such as about 30 mm.

**[0053]** The first electrode may form an open loop. The second electrode may form an open loop and/or the third electrode may form an open loop. The fourth electrode may form an open loop. The fifth electrode may form an open loop. Open loop electrode(s) enables electrode arrangement in few or a single electrode layer.

**[0054]** The base plate may comprise a second adhesive layer, wherein the plurality of electrodes is arranged between the first adhesive layer and the second adhesive layer.

**[0055]** The electrode assembly may comprise a support layer, also denoted a support film. One or more electrodes may be formed, e.g. printed, on the proximal side of the support layer.

**[0056]** One or more electrodes may be formed, e.g. printed, on the distal side of the support layer. Thus, one or more electrodes may be arranged between the support layer and the first adhesive layer. The electrode assembly may have a stomal opening with a center point.

**[0057]** The support layer may comprise polymeric (e.g. polyurethane, PTFE, PVDF) and/or ceramic (e.g. alumina, silica) materials. In one or more exemplary base plates, the support layer is made of thermoplastic polyurethane (TPU). The support layer material may be made of or comprise one or more of polyester, a thermoplastic elastomer (TPE), polyamide, polyimide, Ethylene-vinyl acetate (EVA), polyurea, and silicones.

**[0058]** Exemplary thermoplastic elastomers of the support layer are styrenic block copolymers (TPS, TPE-s), thermoplastic polyolefin elastomers (TPO, TPE-o), thermoplastic Vulcanizates (TPV, TPE-v), thermoplastic polyurethanes (TPU), thermoplastic copolyester (TPC, TPE-E), and thermoplastic polyamides (TPA, TPE-A).

**[0059]** The electrode assembly/base plate may comprise a masking element configured to insulate at least parts of the electrodes from the first adhesive layer of the base plate. The masking element may comprise one or more, such as a plurality of, sensor point openings. The sensor point openings may comprise primary sensor point openings and/or secondary sensor point openings. The sensor point openings may comprise tertiary sensor point opening(s). The sensor point openings may comprise quaternary sensor point opening(s). A sensor point opening of the masking element overlaps at least one electrode of the electrode assembly when seen in the axial direction, e.g. to form a sensor point. For example, a primary sensor point opening may overlap a (sensing) part of the ground electrode and/or a (sensing) part of the fourth electrode. A secondary sensor point opening may overlap a (sensing) part of the fourth electrode and/or a (sensing) part of the fifth electrode. A tertiary sensor point opening may overlap a (sensing) part of the fifth electrode and/or a (sensing) part of the ground electrode.

**[0060]** The masking element may comprise one or more, such as a plurality of, terminal openings. A terminal opening may overlap with one or more connection parts of electrodes. In one or more exemplary base plates, each terminal opening overlaps with a single connection part of an electrode.

**[0061]** The masking element may comprise polymeric (e.g. polyurethane, PTFE, PVDF) and/or ceramic (e.g. alumina, silica) materials. In one or more exemplary base plates, the masking element is made of or comprises thermoplastic polyurethane (TPU). In one or more exemplary base plates, the masking element is made of or comprises polyester. The masking element material may be made of or comprise one or more of polyester, a thermoplastic elastomer (TPE), polyamide, polyimide, Ethylene-vinyl acetate (EVA), polyurea, and silicones.

**[0062]** Exemplary thermoplastic elastomers of the masking element are styrenic block copolymers (TPS, TPE-s), thermoplastic polyolefin elastomers (TPO, TPE-o), thermoplastic Vulcanizates (TPV, TPE-v), thermoplastic polyurethanes (TPU), thermoplastic copolyester (TPC, TPE-E), and thermoplastic polyamides (TPA, TPE-A).

**[0063]** The base plate may comprise a first intermediate element. The first intermediate element may be arranged between the electrodes/electrode layer and the first adhesive layer and/or between the second layer and the first adhesive layer. The first intermediate layer may be made of an insulating material.

**[0064]** The base plate may comprise a release liner. The release liner is a protective layer that protects adhesive layer(s) during transport and storage and is peeled off by the user prior to applying the base plate on the skin. The release liner may have a stomal opening with a center point.

**[0065]** The base plate may comprise a top layer. The top layer is a protective layer protecting the adhesive layer(s) from external strains and stress when the user wears the ostomy

appliance. The electrodes, e.g. some or all the electrodes, may be arranged between the first adhesive layer and the top layer. The top layer may have a stomal opening with a center point. The top layer may have a thickness in the range from 0.01 mm to 1.0 mm, e.g. in the range from 0.02 mm to 0.2 mm, such as 0.04 mm. The top layer may have a stomal opening with a center point.

**[0066]** The base plate comprises a monitor interface. The monitor interface may be configured for electrically and/or mechanically connecting the ostomy appliance (base plate) to the monitor device. The monitor interface may be configured for wirelessly connecting the ostomy appliance (base plate) to the monitor device. Thus, the monitor interface of the base plate is configured to electrically and/or mechanically couple the ostomy appliance and the monitor device.

**[0067]** The monitor interface of the base plate may comprise, e.g. as part of a first connector of the monitor interface, a coupling part for forming a mechanical connection, such as a releasable coupling between the monitor device and the base plate. The coupling part may be configured to engage with a coupling part of the monitor device for releasably coupling the monitor device to the base plate.

**[0068]** The monitor interface of the base plate may comprise, e.g. as part of a first connector of the monitor interface, a plurality of terminals, such as two, three, four, five, six, seven or more terminals, for forming electrical connections with respective terminals of the monitor device. The monitor interface may comprise a ground terminal element forming a ground terminal. The monitor interface may comprise a first terminal element forming a first terminal, a second terminal element forming a second terminal and optionally a third terminal element forming a third terminal. The monitor interface may comprise a fourth terminal element forming a fourth terminal and/or a fifth terminal element forming a fifth terminal. The monitor interface optionally comprises a sixth terminal element forming a sixth terminal. The terminal elements of the monitor interface may contact respective electrodes (connection parts) of the base plate/electrode assembly. The first intermediate element may be arranged between the terminal elements and the first adhesive layer. The first intermediate element may cover or overlap terminal element(s) of the base plate when seen in the axial direction. Thus, the first adhesive layer may be protected or experience more evenly distributed mechanical stress from the terminal elements of the base plate, in turn reducing the risk of terminal elements penetrating or otherwise damaging the first adhesive layer. The first intermediate element may protect or mechanically and/or electrically shield the first adhesive layer from the terminal elements of the base plate.

**[0069]** A terminal element, such as the ground terminal element, the first terminal element, the second terminal element, the third terminal element, the fourth terminal element, the fifth terminal element and/or the sixth terminal element, may comprise a distal end and a proximal end. A terminal element, such as the ground terminal element, the first terminal element, the second terminal element, the third terminal element, the fourth terminal element, the fifth terminal element and/or the sixth terminal element, may comprise a distal part, a centre part,



and/or a proximal part. The distal part may be between the distal end and the centre part. The proximal part may be between the proximal end and the centre part. The proximal end/proximal part of a terminal element may contact a connection part of an electrode. A terminal element, such as the ground terminal element, the first terminal element, the second terminal element, the third terminal element, the fourth terminal element, the fifth terminal element and/or the sixth terminal element, may be gold plated copper.

**[0070]** The base plate may comprise a coupling ring or other coupling member for coupling an ostomy pouch to the base plate (two-part ostomy appliance). The center point may be defined as a center of the coupling ring.

**[0071]** The base plate has a stomal opening with a center point. The size and/or shape of the stomal opening is typically adjusted by the user or nurse before application of the ostomy appliance to accommodate the user's stoma. In one or more exemplary base plates, the user forms the stomal opening during preparation of the base plate for application.

**[0072]** The monitor device comprises a processor. The processor controls the operation of the monitor device including collection and processing of ostomy data from the base plate of the ostomy appliance, processing of, such as storing, sensor data from sensor unit, and generation/transmission of monitor data to accessory devices.

**[0073]** The monitor device comprises a memory for storing ostomy data and/or parameter data based on the ostomy data. The processor may be configured for processing and storing sensor data in the memory.

**[0074]** The monitor device comprises a monitor device housing optionally made of a plastic material. The monitor device housing may be an elongate housing having a first end and a second end. The monitor device housing may have a length or maximum extension along a longitudinal axis in the range from 1 cm to 10 cm. The monitor device housing may have a width or maximum extension perpendicular to the longitudinal axis in the range from 0.5 cm to 5 cm, such as from 0.8 cm to 3 cm. The monitor device housing may be curve-shaped.

**[0075]** The monitor device housing may have a plurality of sensor openings, e.g. a plurality of sensor openings for a sensor and/or a sensor opening for each of a plurality of sensors. The monitor device may comprise one or more sensor openings in a distal surface of the monitor device. The monitor device may comprise one or more sensor openings in a side surface of the monitor device. The monitor device may comprise one or more sensor openings in an end surface of the monitor device.

**[0076]** The sensor opening in the proximal surface is arranged at a sensor opening distance from the first end. The sensor opening distance, also denoted  $D_S$ , may be in the range from  $0.25L$  to  $0.75L$ , such as from  $0.35L$  to  $0.65L$ , where  $L$  is the length of the monitor device housing. The sensor opening distance may be in the range from 10 mm to 70 mm.

**[0077]** The monitor device housing comprises or forms a sensor path from surroundings of the proximal surface to the first sensor surface. The sensor path translates temperature and/or humidity at the proximal surface of the monitor device/monitor device housing to the first sensor surface. The sensor opening forms a part of the sensor path and has a cross-sectional area optionally in the range from 0.2 mm<sup>2</sup> to 10 mm<sup>2</sup>. The sensor opening may be a circular sensor opening with a diameter in the range from 0.3 mm to 1.4 mm, e.g. from 0.6 mm to 1.0 mm.

**[0078]** The monitor device comprises a sensor unit with one or more sensors including a first sensor. The sensor unit is connected to the processor for feeding sensor data to the processor. The sensor unit may comprise a humidity sensor for provision of humidity data to the processor. Thus, the sensor data may comprise humidity data. For example, the first sensor may be a humidity sensor for provision of humidity data to the processor. Thus, the present disclosure enables humidity detection near the skin of a user and/or on the distal side of the base plate, which in turn can be used for a more accurate estimation of base plate operation state.

**[0079]** The sensor unit may comprise a temperature sensor for provision of temperature data to the processor. Thus, the sensor data may comprise temperature data. For example, the first sensor may be a temperature sensor for provision of temperature data to the processor. Thus, the present disclosure enables temperature detection near the skin of a user and/or on the distal side of the base plate, which in turn can be used for a more accurate estimation of base plate operation state.

**[0080]** The first sensor may be a combined humidity and temperature sensor for provision of humidity and temperature data to the processor.

**[0081]** The sensor unit of the monitor device may comprise a second sensor, e.g. an accelerometer for provision of acceleration data to the processor. The sensor unit of the monitor device may comprise a third sensor, e.g. a gyroscope for provision of gyroscope data to the processor. The sensor unit of the monitor device may comprise a fourth sensor, e.g. a magnetometer for provision of magnetometer data to the processor.

**[0082]** The processor is configured for processing ostomy data obtained from the base plate and generate or determine monitor data that are transmitted to an accessory device. The monitor data may comprise sensor data obtained from the sensor unit.

**[0083]** The monitor device comprises a first interface for connecting the monitor device to the base plate. The first interface may be arranged in the proximal surface of the monitor device housing. The first interface may be arranged within a first interface distance from the first end. The first interface distance may be less than 0.50L, such as less than 0.4L, where L is the length of the monitor device housing.

**[0084]** The monitor device may comprise a sealing element forming a seal between the first

sensor and a housing part of the monitor device housing. The sealing element may be an O-ring, e.g. made of a rubber material. The sealing element may encircle the first sensor surface to expose the first sensor surface (membrane) to the sensor path while providing a closed cavity of the monitor device, the closed cavity accommodating PCB, processor, and other electronic circuitry. A glue may form the sealing element.

**[0085]** The ostomy system enables a reliable and accurate measurement of different parameters relevant for monitoring of the ostomy appliance (e.g., monitoring of the base plate). In the ostomy system, a distance between the proximal surface of the monitor device and a distal surface of the base plate, in a coupled state, is in the range from 0.2 mm to 10 mm, such as in the range from 0.5 mm to 5 mm. In the coupled state, the monitor device is attached to the base plate and arranged in its intended position during use of the ostomy system.

**[0086]** The monitor device comprises a first interface connected to the processor. The first interface may be configured as an appliance interface for electrically and/or mechanically connecting the monitor device to the ostomy appliance. Thus, the appliance interface is configured to electrically and/or mechanically couple the monitor device and the ostomy appliance. The first interface may be configured as an accessory device interface for electrically and/or mechanically connecting the monitor device to an accessory device, such as a docking station. The first interface may be configured for coupling to a docking station of the ostomy system, e.g. for charging the monitor device and/or for data transfer between the monitor device and the docking station.

**[0087]** The first interface of the monitor device may comprise a plurality of terminals, such as two, three, four, five, six, seven or more terminals, for forming electrical connections with respective terminals and/or electrodes of the ostomy appliance. One or more terminals of the first interface may be configured for forming electrical connections with an accessory device, e.g. with respective terminals of a docking station. The first interface may comprise a ground terminal. The first interface may comprise a first terminal, a second terminal and optionally a third terminal. The first interface may comprise a fourth terminal and/or a fifth terminal. The first interface optionally comprises a sixth terminal. In one or more exemplary monitor devices, the first interface has M terminals, wherein M is an integer in the range from 4 to 8.

**[0088]** The first interface of the monitor device may comprise a coupling part for forming a mechanical connection, such as a releasable coupling between the monitor device and the base plate. The coupling part and the terminals of the first interface form (at least part of) a first connector of the monitor device.

**[0089]** The monitor device comprises a power unit for powering the monitor device. The power unit may comprise a battery. The power unit may comprise charging circuitry connected to the battery and terminals of the first interface for charging the battery via the first interface, e.g. the first connector. The first interface may comprise separate charging terminal(s) for charging the battery.

**[0090]** The monitor device comprises a second interface connected to the processor. The second interface may be configured as an accessory interface for connecting, e.g. wirelessly connecting, the monitor device to one or more accessory devices. The second interface may comprise an antenna and a wireless transceiver, e.g. configured for wireless communication at frequencies in the range from 2.4 to 2.5 GHz. The wireless transceiver may be a Bluetooth transceiver, i.e. the wireless transceiver may be configured for wireless communication according to Bluetooth protocol, e.g. Bluetooth Low Energy, Bluetooth 4.0, Bluetooth 5. The second interface optionally comprises a loudspeaker and/or a haptic feedback element for provision of an audio signal and/or haptic feedback to the user, respectively. The processor may be configured to transmit monitor data, as a wireless monitor signal via the antenna and the wireless transceiver.

**[0091]** The ostomy system may comprise a docking station forming an accessory device of the ostomy system. The docking station may be configured to electrically and/or mechanically couple the monitor device to the docking station.

**[0092]** The docking station may comprise a docking monitor interface. The docking monitor interface may be configured for electrically and/or mechanically connecting the monitor device to the docking station. The docking monitor interface may be configured for wirelessly connecting the monitor device to the docking station. The docking monitor interface of the docking station may be configured to electrically and/or mechanically couple the docking station and the monitor device.

**[0093]** The docking monitor interface of the docking station may comprise, e.g. as part of a first connector of the docking monitor interface, a coupling part for forming a mechanical connection, such as a releasable coupling between the monitor device and the docking station. The coupling part may be configured to engage with a coupling part of the monitor device for releasably coupling the monitor device to the docking station.

**[0094]** The docking monitor interface of the docking station may comprise, e.g. as part of a first connector of the docking monitor interface, a plurality of terminals, such as two, three, four, five, six, seven or more terminals, for forming electrical connections with respective terminals of the monitor device. The docking monitor interface may comprise a ground terminal. The docking monitor interface may comprise a first terminal and/or a second terminal. The docking station may comprise a third terminal. The docking monitor interface may comprise a fourth terminal and/or a fifth terminal. The docking monitor interface optionally comprises a sixth terminal.

**[0095]** The accessory device comprises a memory, a processor and an interface coupled to the processor. The interface comprises a display, such as a touch-sensitive display

**[0096]** The interface of the accessory device is configured to communicate with monitor device and/or server device. The interface of the accessory device may be configured to

communicate with server device via a network.

**[0097]** The interface of the accessory device may be configured as a monitor interface for connecting, e.g. wirelessly connecting, the accessory device to one or more monitor devices. The interface of the accessory device may comprise an antenna and a wireless transceiver, e.g. configured for wireless communication at frequencies in the range from 2.4 to 2.5 GHz. The wireless transceiver may be a Bluetooth transceiver, i.e. the wireless transceiver may be configured for wireless communication according to Bluetooth protocol, e.g. Bluetooth Low Energy, Bluetooth 4.0, Bluetooth 5.

**[0098]** The accessory device is configured to receive monitor data from one or more monitor devices. The accessory device may be configured to transmit accessory data, e.g. to a server device. For example, the processor of the accessory device may be configured to transmit accessory data, as a wireless accessory signal via the antenna and the wireless transceiver.

**[0099]** The interface of the accessory device comprises a display and is configured to obtain monitor data from the monitor device coupled to the ostomy appliance. The monitor data may comprise sensor data obtained from one or more sensors in the monitor device. The monitor data may comprise ostomy data obtained from electrodes of the base plate, and/or parameter data based on ostomy data obtained from electrodes of the base plate.

**[0100]** The monitor data may be indicative of a condition of the ostomy appliance, e.g. a condition of the base plate disclosed herein. The condition of the ostomy appliance or of the base plate disclosed herein may refer to a level of a physical property of at least a part of the ostomy appliance, such as a level of moisture and/or temperature of at least a part of the base plate, such as a level of a physical property of at least a layer of the base plate, such as a level of moisture and/or temperature of at least a layer of the base plate, such as a level of a physical property of at least an adhesive layer of the base plate (e.g. a first adhesive layer proximal to the skin of the user). In one or more exemplary accessory devices, the interface is configured to obtain the monitor data by obtaining the monitor data indicative of the condition comprising a moisture level of a first adhesive layer of the base plate and/or a moisture level of a proximal side of the first adhesive layer. The moisture level may be seen as representative of a conductive path in the first adhesive layer, such as across the first adhesive layer. The monitor data comprises e.g. data representative of the measurement of the electrical properties of the first adhesive layer. In other words, the condition may be seen as a condition of the first adhesive layer.

**[0101]** A user interface refers herein to a graphical representation comprising a collection of user interface objects. A user interface comprises one or more user interface objects. A user interface may be referred to as a user interface screen.

**[0102]** A user interface object refers herein to a graphical representation of an object that is displayed on the display of the accessory device. The user interface object may be user-interactive, or selectable by a user input. For example, an image (e.g., icon), a button, and text

(e.g., hyperlink) each optionally constitute a user interface object. The user interface object may form part of a widget. A widget may be seen as a mini-application that may be used by the user, and created by the user. A user interface object may comprise a prompt, application launch icon, and/or an action menu. An input, such as first input and/or second input, may comprise a touch (e.g. a tap, a force touch, a long press), a and/or movement of contact (e.g. a swipe gesture, e.g. for toggling). The movement on contact may be detected by a touch sensitive surface, e.g. on a display of an accessory device. Thus, the display may be a touch sensitive display. An input, such as first input and/or second input, may comprise a lift off. An input, such as first input and/or second input, may comprise a touch and a movement followed by a lift off.

**[0103]** The display of the accessory device may be configured to detect touch (e.g. the display is a touch-sensitive display), the input comprises a contact on the touch sensitive display. A touch-sensitive display provides an input interface and an output interface between the accessory device and a user. A processor of the accessory device may be configured to receive and/or send electrical signals from/to touch-sensitive display. A touch-sensitive display is configured to display visual output to the user. The visual output optionally includes graphics, text, icons, video, and any combination thereof (collectively termed "graphics"). For example, some or all of the visual output may be seen as corresponding to user-interface objects.

**[0104]** The processor of the accessory device may be configured to display, on the display, one or more user interfaces, such as user interface screens, including a first user interface and/or a second user interface. A user interface may comprise one or more, such as a plurality of user interface objects. For example, the first user interface may comprise a first primary user interface object and/or a first secondary user interface object. A second user interface may comprise a second primary user interface object and/or a second secondary user interface object. A user interface object, such as the first primary user interface object and/or the second primary user interface object, may represent an operating state of the base plate.

**[0105]** An operating state in the present disclosure is indicative of the dynamic internal state of the ostomy appliance (e.g. of the base plate of the ostomy appliance currently being worn by the user) optionally related to adhesive performance of the ostomy appliance. Adhesive performance of the ostomy appliance may be related to an internal condition of the ostomy appliance (e.g. of the base plate of the ostomy appliance), such as an internal condition of an adhesive layer of the ostomy appliance. The adhesive performance, and thereby the operating state may be affected by several factors, such as humidity, temperature, misplacement of the ostomy appliance on the stoma, and/or malfunction of the ostomy appliance. The one or more factors alone or in combination impact the adhesive performance of the ostomy appliance. The operating state may be varying in time. The operating state may be indicative of a degree of erosion of the base plate.

**[0106]** Adhesive performance may be indicative of wear property, e.g. wear time and/or wear comfort. The operating state may comprise at least one of: a wear time, a quality of adhesion, and a moisture pattern representation. Wear time may comprise average wear time, nominal

wear time, minimal wear time, maximal wear time, median wear time, and/or any of other statistical metric derivable from wear time. Wear time may comprise remaining wear time and/or current wear time and/or elapsed wear time. A quality of adhesion may comprise a metric indicative of erosion of a layer of the base plate, such as of the first adhesive layer. A moisture pattern representation may comprise one or more metrics or parameters representative or indicative of a moisture pattern (e.g. a moisture pattern type), e.g. a moisture pattern of the first adhesive layer.

**[0107]** An operating state may be configured to indicate whether the ostomy appliance is properly operational based on its adhesive performance (e.g. wear property, e.g. wear time and/or wear comfort). For example, the operating state may be indicative of the severity and/or imminence of a leakage (e.g. low, medium, acute). The operating state may comprise Z operating states, where Z is an integer. The operating state may comprise a first operating state, a second operating state, and/or a third operating state (e.g. good, check, change in X time/NOW).

**[0108]** The monitor device comprises a processor and one or more interfaces, such as a first interface and/or a second interface. The monitor device may comprise a memory for storing ostomy data.

**[0109]** In one or more exemplary monitor devices, the processor is configured to apply a processing scheme, the first interface is connected to the processor and the memory, and the first interface is configured for collecting ostomy data from the base plate coupled to the first interface. The ostomy data may comprise one or more, such as all, of first ostomy data from a first electrode pair of the base plate, second ostomy data from a second electrode pair of the base plate, and third ostomy data from a third electrode pair of the base plate. A second interface is connected to the processor. To apply a processing scheme may comprise one or more of obtain first parameter data based on the first ostomy data; obtain second parameter data based on the second ostomy data; and obtain third parameter data based on the third ostomy data. To apply a processing scheme may comprise determine an operating state of the base plate of the ostomy appliance based on one or more, such as all, of the first parameter data, the second parameter data and the third parameter data. The operating state may be indicative of a degree of radial erosion of the base plate, such as of the first adhesive layer, and/or an acute leakage risk for the ostomy appliance. The monitor device is configured to, in accordance with a determination that the operating state is a first operating state, transmit a first monitor signal comprising monitor data indicative of the first operating state of the base plate via the second interface; and/or in accordance with a determination that the operating state is a second operating state, transmit a second monitor signal comprising monitor data indicative of the second operating state of the base plate via the second interface.

**[0110]** In one or more exemplary monitor devices, the first operating state of the base plate corresponds to a situation wherein the first adhesive layer of the base plate has experienced a first degree of radial erosion, e.g. the first adhesive layer is eroded to a first radial distance of the first electrode pair but not to a second radial distance of the second electrode pair.

**[0111]** In one or more exemplary monitor devices, the second operating state of the base plate corresponds to a situation wherein the first adhesive layer of the base plate has experienced a second degree of radial erosion, e.g. the first adhesive layer is eroded to the second radial distance of the second electrode pair but not to a third radial distance of the third electrode pair.

**[0112]** To obtain first parameter data based on the first ostomy data may comprise determining one or more first parameters based on the first ostomy data. To obtain second parameter data based on the second ostomy data may comprise determining one or more second parameters based on the second ostomy data. To obtain third parameter data based on the third ostomy data may comprise determining one or more third parameters based on the third ostomy data. In one or more exemplary monitor devices, determination of an operating state may be based on one or more first parameters, such as first primary parameter and/or first secondary parameter of first parameter data. In one or more exemplary monitor devices, determination of an operating state may be based on one or more second parameters, such as second primary parameter and/or second secondary parameter of the second parameter data. In one or more exemplary monitor devices, determination of an operating state may be based on one or more third parameters, such as third primary parameter and/or third secondary parameter of the third parameter data. In one or more exemplary monitor devices, determination of an operating state may be based on one or more fourth parameters, such as fourth primary parameter and/or fourth secondary parameter of the fourth parameter data.

**[0113]** The first parameter data, the second parameter data, and the third parameter data may be indicative of resistance between the first electrode pair, the second electrode pair, and the third electrode pair, respectively. The first parameter data, the second parameter data, and the third parameter data may be indicative of voltage between the first electrode pair, the second electrode pair, and the third electrode pair, respectively (and thus indicative of resistance). The first parameter data, the second parameter data, and the third parameter data may be indicative of current between the first electrode pair, the second electrode pair, and the third electrode pair, respectively (and thus indicative of resistance).

**[0114]** The first parameter data, the second parameter data, and the third parameter data may be indicative of a rate of change in resistance between the first electrode pair, the second electrode pair, and the third electrode pair, respectively. In one or more exemplary monitor devices, the first parameter data, the second parameter data, and the third parameter data may be indicative of a rate of change in voltage between the first electrode pair, the second electrode pair, and the third electrode pair, respectively. In one or more exemplary monitor devices, the first parameter data, the second parameter data, and the third parameter data may be indicative of a rate of change in current between the first electrode pair, the second electrode pair, and the third electrode pair, respectively.

**[0115]** In one or more exemplary monitor devices, to determine an operating state of the base plate is based on a first criteria set based on the first parameter data and/or the second



parameter data, wherein the operating state is determined to be the first operating state if the first criteria set is satisfied. The first criteria set may comprise one or more first criteria based on one or more of first parameter data, second parameter data and third parameter data. The first criteria set may comprise a first primary criterion based on the first parameter data. The first criteria set may comprise a first secondary criterion based on the second parameter data. The first criteria set may comprise a first tertiary criterion based on the third parameter data.

**[0116]** In one or more exemplary monitor devices, to determine an operating state of the base plate may be based on a first threshold set comprising one or a plurality of first threshold values. The first threshold set may comprise one or a plurality of threshold values, e.g. to be applied in the first criteria set. The first threshold set may comprise a first primary threshold value. The first threshold set may comprise a first secondary threshold value. The first threshold set may comprise a first tertiary threshold value.

**[0117]** The first criteria set may be given by or at least may comprise:

$(P_{1_1} < TH_{1_1}),$

$(P_{2_1} > TH_{1_2}),$

and

$(P_{3_1} > TH_{1_3}),$

wherein  $P_{1_1}$  is a first primary parameter based on the first parameter data,  $TH_{1_1}$  is a first primary threshold value,  $P_{2_1}$  is a second primary parameter based on the second parameter data,  $TH_{1_2}$  is a first secondary threshold value,  $P_{3_1}$  is a third primary parameter based on the third parameter data, and  $TH_{1_3}$  is a first tertiary threshold value, and wherein the first operating state is indicative of low degree of radial erosion on the base plate. The first threshold values ( $TH_{1_1}$ ,  $TH_{1_2}$  and  $TH_{1_3}$ ) may be the same or different, e.g. depending on the electrode configuration of the base plate. The first tertiary criterion ( $P_{3_1} < TH_{1_3}$ ) may be omitted in the first criteria set. The first operating state, e.g. indicative of low degree of radial erosion on the base plate may be indicative of a radial progression of moisture to the first electrode pair (but not to the second electrode pair and not to the third electrode pair) which corresponds to e.g. an un-alarming and/or normal radial progression of moisture.

**[0118]** In one or more exemplary embodiments, when the first parameter data, the second parameter data and the third parameter data are each respectively indicative of resistance between the first electrode pair, the second electrode pair and the third electrode pair respectively, the first threshold values ( $TH_{1_1}$ ,  $TH_{1_2}$  and  $TH_{1_3}$ ) may correspond to first resistance threshold values. In one or more exemplary embodiments, the first primary threshold value  $TH_{1_1}$  may correspond to an upper resistance threshold value. An upper resistance threshold value may be set to a value which is less than 30 Mega-Ohms, such as 25 Mega-Ohms, such as 20.5 Mega-Ohms, such as 20.4 Mega-Ohms. In one or more exemplary embodiments, the first secondary threshold value  $TH_{1_2}$  may correspond to the upper resistance threshold value. In one or more exemplary embodiments, the first tertiary threshold value  $TH_{1_3}$  may correspond to the upper resistance threshold value. The first primary parameter  $P_{1_1}$  may be indicative of the resistance between the first electrode pair (first

electrode and first electrode part of the ground electrode) of the base plate. The first parameter data may comprise a first secondary parameter which may be derived from the first primary parameter, and/or a first tertiary parameter, which may be derived from the first primary parameter. A first secondary parameter P\_1\_2 may comprise or be a gradient derived from the first primary parameter. In one or more embodiments, a first primary parameter P\_1\_1 may be indicative of a voltage between the first electrode pair (first electrode and first electrode part of the ground electrode) of the base plate.

**[0119]** In one or more exemplary embodiments, when the first parameter data, the second parameter data and the third parameter data are each respectively indicative of voltage between the first electrode pair, the second electrode pair and the third electrode pair respectively, the first threshold values (TH\_1\_1, TH\_1\_2 and TH\_1\_3) may correspond to first voltage threshold values. In one or more exemplary embodiments, the first primary threshold value TH\_1\_1 may correspond to an upper voltage threshold value. An upper voltage threshold value may be set to a value less than 5 Volts, such as 3 Volts, such as 2, 86 Volts. In one or more exemplary embodiments, the first secondary threshold value TH\_1\_2 may correspond to the upper voltage threshold value. In one or more exemplary embodiments, the first tertiary threshold value TH\_1\_3 may correspond to the upper voltage threshold value.

**[0120]** The first criteria set may comprise e.g.

(P\_4\_1 > TH\_1\_4)

wherein P\_4\_1 is a fourth primary parameter based on the fourth parameter data and indicative of the resistance, voltage, or current between the fourth electrode pair and TH\_1\_4 is a first quaternary threshold value, and wherein the first operating state is indicative of absence of fluid on the proximal side of the first adhesive layer of the base plate of the ostomy appliance. In one or more exemplary embodiments, the first quaternary threshold value TH\_1\_4 may correspond to an upper resistance threshold value. An upper resistance threshold value may be set to a value which is less than 30 Mega-Ohms, such as 25 Mega-Ohms, such as 20.5 Mega-Ohms, such as 20.4 Mega-Ohms.

**[0121]** In one or more exemplary embodiments, the following additional criterion may be determined

(P\_1\_1 < TH\_low),

wherein P\_1\_1 is a first primary parameter based on the first parameter data, TH\_low is a threshold value corresponding to a lower resistance threshold value. In one or more exemplary embodiments, a lower resistance threshold value may be set to a value less than 1 Mega-Ohms, such as 100 kilo-Ohms, such as 80 kilo-Ohms, such as 79 kilo-Ohms. This is indicative of a saturation of the first electrode pair by the moisture detected and there are no further changes expected by the first primary parameter. Moisture is likely to continue its progression.

**[0122]** In one or more exemplary embodiments, the following additional criterion may be determined

(P\_2\_1 < TH\_low),

wherein P\_2\_1 is a second primary parameter based on the second parameter data, TH\_low is a threshold value corresponding to a lower resistance threshold value. In one or more

exemplary embodiments, a lower resistance threshold value may be set to a value less than 1 Mega-Ohms, such as 100 kilo-Ohms, such as 80 kilo-Ohms, such as 79 kilo-Ohms. This is indicative of a saturation of the second electrode pair by the moisture detected and there are no further changes expected by the second primary parameter. Moisture is likely to continue its progression.

**[0123]** In one or more exemplary embodiments, the following additional criterion may be determined:  
( $P_{3\_1} > TH_{low}$ ),

**[0124]**  $P_{3\_1}$  is a third primary parameter based on the third parameter data, and  $TH_{low}$  is a threshold value corresponding to a lower resistance threshold value. In one or more exemplary embodiments, a lower resistance threshold value may be set to a value less than 1 Mega-Ohms, such as 100 kilo-Ohms, such as 80 kilo-Ohms, such as 79 kilo-Ohms. This is indicative of a saturation of the third electrode pair by the moisture detected and there are no further changes expected by the second primary parameter. Moisture is likely to continue its progression.

**[0125]** In one or more exemplary embodiments, one or more criteria of a criteria set, e.g. one or more first criteria of the first criteria set and/or one or more second criteria of the second criteria set, may be based on timing information or one or more delay parameters based on the parameter data. In one or more exemplary embodiments, one or more delay parameters or time differences related to different parameter data, e.g. related to the first parameter data and the second parameter data, are determined.

**[0126]** In one or more exemplary embodiments, one or more first criteria of the first criteria set may be based on timing information (e.g. one or more delay parameters of the parameter data and/or one or more times where a parameter crosses a threshold).

**[0127]** In one or more exemplary embodiments, the timing information may comprise a time difference  $D_{1\_2\_1}$  between a time  $T1$  where  $P_{1\_1}$  crosses a threshold, such as  $TH_{1\_1}$ , and a time  $T2$  where  $P_{2\_1}$  crosses a threshold, such as  $TH_{1\_2}$ . Thus, delay parameter or time difference  $D_{1\_2\_1}$  may be given as  $D_{1\_2\_1} = T2 - T1$ .

**[0128]** In one or more exemplary embodiments, the timing information, e.g. used in the first criteria set, may comprise a time difference  $D_{2\_3\_1}$  between a time  $T2$  where  $P_{2\_1}$  crosses a threshold, such as  $TH_{1\_2}$ , and a time  $T3$  where  $P_{3\_1}$  crosses a threshold, such as  $TH_{1\_3}$ . Thus, delay parameter or time difference  $D_{2\_3\_1}$  may be given as  $D_{2\_3\_1} = T3 - T2$ .

**[0129]** In one or more exemplary embodiments, one or more criteria sets, such as the third criteria set and/or the second criteria set, may comprise any of:  
 $D_{1\_2\_1} > Z$

D\_2\_3\_1 > Z

**[0130]** Wherein Z is a time difference constant characterizing the progression of moisture (e.g. 3h, e.g. 2h). Different time difference constants may be employed in different criteria sets/for different time delays.

**[0131]** In one or more exemplary embodiments, one or more criteria sets, such as the second criteria set and/or the third criteria set may comprise any of:

D\_1\_2\_1 > Z

**[0132]** Wherein Z is a time difference constant characterizing the progression of moisture (e.g. 3h, e.g. 2h).

**[0133]** The second primary parameter may be indicative of the resistance between the second electrode pair (second electrode and second electrode part of the ground electrode) of the base plate.

**[0134]** The second parameter data may comprise a second secondary parameter, and/or a second tertiary parameter, which may be derived from the second primary parameter. A second secondary parameter may be indicative of a voltage between the second electrode pair (second electrode and second electrode part of the ground electrode) of the base plate.

**[0135]** The third primary parameter may be indicative of resistance between the third electrode pair (third electrode and third electrode part of the ground electrode) of the base plate. The third parameter data may comprise a third secondary parameter, and/or a third tertiary parameter, which may be derived from the third primary parameter. A third secondary parameter may be indicative of a voltage between the second electrode pair (second electrode and second electrode part of the ground electrode) of the base plate.

**[0136]** In one or more exemplary monitor devices, to determine an operating state of the base plate is based on a second criteria set based on the second parameter data and/or the third parameter data, wherein the operating state is determined to be the second operating state if the second criteria set is satisfied. The second criteria set may be based on the first parameter data.

**[0137]** The second criteria set may comprise one or more second criteria based on one or more of first parameter data, second parameter data and third parameter data. The second criteria set may comprise a second primary criterion based on the first parameter data. The second criteria set may comprise a second secondary criterion based on the second parameter data. The second criteria set may comprise a second tertiary criterion based on the third parameter data.

**[0138]** In one or more exemplary monitor devices, to determine an operating state of the base plate is based on a second threshold set comprising one or a plurality of second threshold values. The second threshold set may comprise one or a plurality of threshold values, e.g. to be applied in the second criteria set. The second threshold set may comprise a second primary threshold value. The second threshold set may comprise a second secondary threshold value. The second threshold set may comprise a second tertiary threshold value.

**[0139]** The second criteria set may be given by or least may comprise:

$(P_{1_1} < TH_{2_1})$ ,

$(P_{2_1} < TH_{2_2})$ ,

and

$(P_{3_1} > TH_{2_3})$

wherein  $P_{1_1}$  is a first primary parameter based on the first parameter data and indicative of the resistance between the first electrode pair,  $TH_{2_1}$  is a second primary threshold value,  $P_{2_1}$  is a second primary parameter based on the second parameter data and indicative of the resistance between the second electrode pair,  $TH_{2_2}$  is a second secondary threshold value,  $P_{3_1}$  is a third primary parameter based on the third parameter data and indicative of the resistance between the third electrode pair,  $TH_{2_3}$  is a second tertiary threshold value, and wherein the second operating state is indicative of medium degree of radial erosion on the base plate. The second threshold values ( $TH_{2_1}$ ,  $TH_{2_2}$  and  $TH_{2_3}$ ) may be the same or different, e.g. depending on the electrode configuration of the base plate. The second primary criterion ( $P_{1_1} < TH_{2_1}$ ) and/or the second tertiary criterion ( $P_{3_1} > TH_{2_3}$ ) may be omitted in the second criteria set. The second operating state indicative of medium degree of radial erosion on the base plate may be indicative of a radial progression of moisture to the first electrode pair and the second electrode pair (and not the third electrode pair). The second operating state indicative of medium degree of radial erosion on the base plate may be indicative of a radial progression of moisture to the first electrode pair and to the second electrode pair. In one or more exemplary embodiments, when the first parameter data, the second parameter data and the third parameter data are each respectively indicative of resistance between the first electrode pair, the second electrode pair and the third electrode pair respectively, the second threshold values ( $TH_{2_1}$ ,  $TH_{2_2}$  and  $TH_{2_3}$ ) may correspond to second resistance threshold values. In one or more exemplary embodiments, the second primary threshold value  $TH_{2_1}$  may correspond to an upper resistance threshold value. An upper resistance threshold value may be set to a value which is less than 30 Mega-Ohms, such as 25 Mega-Ohms, such as 20.5 Mega-Ohms, such as 20.4 Mega-Ohms. In one or more exemplary embodiments, the second secondary threshold value  $TH_{2_2}$  may correspond to the upper resistance threshold. In one or more exemplary embodiments, the second tertiary threshold value  $TH_{2_3}$  may correspond to the upper resistance threshold value. In one or more exemplary embodiments, the second primary threshold value  $TH_{2_1}$  may correspond to a medium resistance threshold value. A medium resistance threshold value may be set to a value less than 10 Mega-Ohms, such as 5 Mega-Ohms, such as 3 Mega-Ohms, such as 2 Mega-Ohms, such as 1 Mega-Ohms.

**[0140]** In one or more exemplary embodiments, when the first parameter data, the second

parameter data and the third parameter data are each respectively indicative of voltage between the first electrode pair, the second electrode pair and the third electrode pair respectively, the second threshold values (TH\_2\_1, TH\_2\_2 and TH\_2\_3) may correspond to second voltage threshold values. In one or more exemplary embodiments, the second primary threshold value TH\_2\_1 may correspond to an upper voltage threshold value. An upper voltage threshold value may be set to a value less than 5 Volts, such as 3 Volts, such as 2.86 Volts. In one or more exemplary embodiments, the second secondary threshold value TH\_2\_2 may correspond to the upper voltage threshold value. In one or more exemplary embodiments, the second tertiary threshold value TH\_2\_3 may correspond to the upper voltage threshold value. In one or more exemplary embodiments, the second primary threshold value TH\_2\_1 may correspond to a medium voltage threshold value. A medium resistance threshold value may be set to a value less than 10 Mega-Ohms, such as 5 Mega-Ohms, such as 3 Mega-Ohms, such as 2 Mega-Ohms, such as 1 Mega-Ohms.

**[0141]** In one or more exemplary embodiments, the second criteria set may comprise any of:  
 $D_{1_2_1} > Z$

**[0142]** Wherein Z is a time difference constant characterizing the progression of moisture (e.g. 3h, e.g. 2h).

**[0143]** In one or more exemplary monitor devices, to determine an operating state of the base plate is based on a default criteria set based on the first parameter data, wherein the operating state is determined to be the default operating state if the default criteria set is satisfied, and in accordance with a determination that the operating state is the default operating state, transmit a default monitor signal comprising monitor data indicative of the default operating state of the ostomy appliance (e.g., operating state of the base plate).

**[0144]** The default criteria set may be given by or at least may comprise:  
 $(P_{1_1} > TH_{D_1})$ ,

$(P_{2_1} > TH_{D_2})$ ,

and

$(P_{3_1} > TH_{D_3})$

wherein P\_1\_1 is a first primary parameter based on the first parameter data and indicative of the resistance between the first electrode pair, TH\_D\_1 is a default primary threshold value, P\_2\_1 is a second primary parameter based on the second parameter data and indicative of the resistance between the second electrode pair, TH\_D\_2 is a default secondary threshold value, P\_3\_1 is a third primary parameter based on the third parameter data and indicative of the resistance between the third electrode pair, TH\_D\_3 is a default tertiary threshold value, and wherein the default operating state is indicative of very low or no degree of radial erosion on the base plate. The default threshold values (TH\_D\_1, TH\_D\_2 and TH\_D\_3) may be the same or different, e.g. depending on the electrode configuration of the base plate. In one or more exemplary embodiments, when the first parameter data, the second parameter data and the third parameter data are each respectively indicative of resistance between the first

electrode pair, the second electrode pair and the third electrode pair respectively, the default threshold values (TH\_D\_1, TH\_D\_2 and TH\_D\_3) may correspond to default resistance threshold values. In one or more exemplary embodiments, the second primary threshold value TH\_D\_1 may correspond to an upper resistance threshold value. An upper resistance threshold value may be set to a value which is less than 30 Mega-Ohms, such as 25 Mega-Ohms, such as 20.5 Mega-Ohms, such as 20.4 Mega-Ohms. In one or more exemplary embodiments, the default secondary threshold value TH\_D\_2 may correspond to the upper resistance threshold. In one or more exemplary embodiments, the default tertiary threshold value TH\_D\_3 may correspond to the upper resistance threshold value.

**[0145]** In one or more exemplary embodiments, when the first parameter data, the second parameter data and the third parameter data are each respectively indicative of voltage between the first electrode pair, the second electrode pair and the third electrode pair respectively, the default threshold values (TH\_D\_1, TH\_D\_2 and TH\_D\_3) may correspond to default voltage threshold values. In one or more exemplary embodiments, the default primary threshold value TH\_D\_1 may correspond to an upper voltage threshold value. An upper voltage threshold value may be set to a value less than 5 Volts, such as 3 Volts, such as 2.86 Volts. In one or more exemplary embodiments, the default secondary threshold value TH\_D\_2 may correspond to the upper voltage threshold value. In one or more exemplary embodiments, the default tertiary threshold value TH\_D\_3 may correspond to the upper voltage threshold value.

**[0146]** In one or more exemplary monitor devices, to determine an operating state of the base plate is based on a third criteria set based on the third parameter data, wherein the operating state is determined to be the third operating state if the third criteria set is satisfied, and in accordance with a determination that the operating state is the third operating state, transmit a third monitor signal comprising monitor data indicative of the third operating state of the ostomy appliance.

**[0147]** In one or more exemplary monitor devices, the third operating state of the base plate corresponds to a situation wherein the first adhesive layer of the base plate has experienced a third degree of radial erosion, e.g. the first adhesive layer is eroded to the third radial distance of the third electrode pair.

**[0148]** The third criteria set may be given by or at least may comprise:

$(P_{1_1} < TH_{3_1}),$

$(P_{2_1} < TH_{3_2}),$

and

$(P_{3_1} < TH_{3_3})$

wherein  $P_{1_1}$  is a first primary parameter based on the first parameter data and indicative of the resistance between the first electrode pair,  $TH_{3_1}$  is a third primary threshold value,  $P_{2_1}$  is a second primary parameter based on the second parameter data and indicative of the resistance between the second electrode pair,  $TH_{3_2}$  is a third secondary threshold value,  $P_{3_1}$  is a third primary parameter based on the third parameter data and indicative of

the resistance between the third electrode pair, TH\_3\_3 is a third tertiary threshold value, and wherein the third operating state is indicative of high degree of radial erosion on the base plate. The third threshold values (TH\_3\_1, TH\_3\_2 and TH\_3\_3) may be the same or different, e.g. depending on the electrode configuration of the base plate. The third primary criterion ( $P_{1_1} < TH_{3_1}$ ) and/or the third secondary criterion ( $P_{2_1} < TH_{3_2}$ ) may be omitted in the third criteria set. The third operating state indicative of high degree of radial erosion on the base plate may be indicative of high likelihood of leakage, e.g. on the proximal side of the base plate, e.g. within a time period e.g. within the next 20 minutes. The third operating state may indicate a radial progression of moisture to the first electrode pair, the second electrode pair, and the third electrode pair.

**[0149]** In one or more exemplary embodiments, when the first parameter data, the second parameter data and the third parameter data are each respectively indicative of resistance between the first electrode pair, the second electrode pair and the third electrode pair respectively, the third threshold values (TH\_3\_1, TH\_3\_2 and TH\_3\_3) may correspond to third resistance threshold values. In one or more exemplary embodiments, the third primary threshold value TH\_3\_1 may correspond to an upper resistance threshold value. In one or more exemplary embodiments, the third secondary threshold value TH\_3\_2 may correspond to an upper resistance threshold value. In one or more exemplary embodiments, the third tertiary threshold value TH\_3\_3 may correspond to an upper resistance threshold value. An upper resistance threshold value may be set to a value which is less than 30 Mega-Ohms, such as 25 Mega-Ohms, such as 20.5 Mega-Ohms, such as 20.4 Mega-Ohms.

**[0150]** In one or more exemplary embodiments, the third primary threshold value TH\_3\_1 may correspond to a lower resistance threshold value. In one or more exemplary embodiments, a lower resistance threshold value may be set to a value less than 1 Mega-Ohms, such as 100 kilo-Ohms, such as 80 kilo-Ohms, such as 79 kilo-Ohms. In one or more exemplary embodiments, the third secondary threshold value TH\_3\_2 may correspond to a medium resistance threshold. A medium resistance threshold value may be set to a value less than 10 Mega-Ohms, such as 5 Mega-Ohms, such as 3 Mega-Ohms, such as 2 Mega-Ohms, such as 1 Mega-Ohms. In one or more exemplary embodiments, the third tertiary threshold value TH\_3\_3 may correspond to the upper resistance threshold. An upper resistance threshold value may be set to a value which is less than 30 Mega-Ohms, such as 25 Mega-Ohms, such as 20.5 Mega-Ohms, such as 20.4 Mega-Ohms.

**[0151]** In one or more exemplary embodiments, when the first parameter data, the second parameter data and the third parameter data are each respectively indicative of voltage between the first electrode pair, the second electrode pair and the third electrode pair respectively, the third threshold values (TH\_3\_1, TH\_3\_2 and TH\_3\_3) may correspond to third voltage threshold values. In one or more exemplary embodiments, the third primary threshold value TH\_3\_1 may correspond to an upper voltage threshold value. In one or more exemplary embodiments, the third secondary threshold value TH\_3\_2 may correspond to an upper voltage threshold value. In one or more exemplary embodiments, the second tertiary threshold value TH\_2\_3 may correspond to the upper voltage threshold value.



**[0152]** In one or more exemplary embodiments, the third primary threshold value TH\_3\_1 may correspond to a lower voltage threshold value. In one or more exemplary embodiments, a lower voltage threshold value may be set to a value which is less than 1 Volt, such as 0.5 Volt, such as 0.25 Volts, such as 0.22 Volts. In one or more exemplary embodiments, the third secondary threshold value TH\_3\_2 may correspond to a medium voltage threshold value. A medium voltage threshold value may be set to a value less than 2 Volts, such as 1.5 Volts. In one or more exemplary embodiments, the second tertiary threshold value TH\_2\_3 may correspond to the upper voltage threshold value.

**[0153]** In one or more exemplary embodiments, the third criteria set may comprise any of:

$D_{1_2_1} < Z$

$D_{2_3_1} < Z$

**[0154]** Wherein Z is a time difference constant characterizing the progression of moisture (e.g. 3h, e.g. 2h), a time difference  $D_{1_2_1}$  between a time T1 where  $P_{1_1}$  crosses TH\_1\_1 and a time T2 where  $P_{2_1}$  crosses TH\_1\_2, and a time difference  $D_{2_3_1}$  between a time T2 where  $P_{2_1}$  crosses TH\_1\_2 and a time T3 where  $P_{3_1}$  crosses TH\_1\_3.

**[0155]** In one or more exemplary monitor devices, the ostomy data comprises fourth ostomy data from a fourth electrode pair of the base plate. To apply a processing scheme may comprise to obtain fourth parameter data based on the fourth ostomy data, and determine an operating state of the base plate of the ostomy appliance based on the fourth parameter data. The monitor device may be configured to, in accordance with a determination that the operating state is a fourth operating state, transmit a fourth monitor signal comprising monitor data indicative of the fourth operating state of the ostomy appliance.

**[0156]** In one or more exemplary monitor devices, the fourth operating state of the base plate corresponds to a situation, wherein the fourth electrode pair detects fluid, such as output, between the proximal surface of first adhesive layer and the skin of the user at a fourth radial distance, and thus there is a high risk of leakage from the ostomy appliance in the fourth operating state.

**[0157]** The fourth criteria set may be given by or at least may comprise:

$(P_{4_1} < TH_{4_4})$

wherein  $P_{4_1}$  is a fourth primary parameter based on the fourth parameter data and indicative of the resistance between the fourth electrode pair and TH\_4\_4 is a fourth quaternary threshold value, and wherein the fourth operating state is indicative of high risk of leakage from the ostomy appliance.

**[0158]** In one or more exemplary embodiments, the fourth quaternary threshold value TH\_4\_4 may correspond to an upper resistance threshold value.

**[0159]** In one or more exemplary embodiments, a fifth operating state of the base plate corresponds to a situation, wherein the fourth electrode pair detects fluid, such as sweat, between the proximal surface of first adhesive layer and the skin of the user at a fourth radial distance, and thus there is a no leakage from the ostomy appliance in the fifth operating state.

**[0160]** The fifth operating state may be determined in accordance with a determination that one or more fifth criterion of a fifth criteria set are satisfied.

**[0161]** The fifth criteria set may be given by or at least may comprise:

$$(P_{4\_1} < TH_{5\_1})$$

$$(P_{4\_2} < TH_{5\_2})$$

$$(P_{4\_3} < TH_{5\_3})$$

$$(\nabla P_{4\_1} < V)$$

$$(\nabla P_{4\_2} < V)$$

and

$$(\nabla P_{4\_3} < V)$$

**[0162]** Wherein  $P_{4\_1}$  is a fourth primary parameter based on the fourth parameter data and indicative of the resistance between the fourth electrode pair,  $P_{4\_2}$  is a fourth secondary parameter indicative of the resistance between the fourth electrode and the fifth electrode,  $P_{4\_3}$  is a fourth tertiary parameter based on the fourth parameter data and indicative of the resistance between the fifth electrode pair and  $TH_{5\_1}$  is a fifth primary threshold value,  $TH_{5\_2}$  is a fifth secondary threshold value,  $TH_{5\_3}$  is a fifth tertiary threshold value and  $OP_{4\_1}$  is gradient of  $P_{4\_1}$ ,  $VP_{4\_2}$  is gradient of  $P_{4\_2}$ ,  $VP_{4\_3}$  is gradient of  $P_{4\_3}$ , and  $V$  is a gradient limit (e.g. 80%). In one or more exemplary embodiments, the fifth primary threshold value  $TH_{5\_1}$  may correspond to an upper resistance threshold value. In one or more exemplary embodiments,  $TH_{5\_2}$  may correspond to an upper resistance threshold value. In one or more exemplary embodiments,  $TH_{5\_3}$  may correspond to an upper resistance threshold value. An upper resistance threshold value may be set to a value which is less than 30 Mega-Ohms, such as 25 Mega-Ohms, such as 20.5 Mega-Ohms, such as 20.4 Mega-Ohms. The fifth operating state may refer to presence of sweat detected by the fourth parameter data indicating moisture detected omnidirectionally from the stomal opening and uniformly.

**[0163]** In one or more exemplary monitor devices, the sixth operating state of the base plate corresponds to a situation, wherein the fourth electrode pair detects fluid, such as output, between the proximal surface of first adhesive layer and the skin of the user at a fourth radial distance, and thus there is a sudden leakage from the ostomy appliance in the sixth operating state.

**[0164]** A sixth operating state may be determined in accordance with a determination that one or more sixth criteria of a sixth criteria set are satisfied by the fourth parameter data.

**[0165]** The sixth criteria set may comprise a sixth primary criterion, wherein the sixth primary criterion may comprise:

$$(P_{4\_1} < TH_{6\_1})$$

and

$$(\nabla P_{4\_1} > V)$$

**[0166]** The sixth criteria set may comprise a sixth secondary criterion, wherein the sixth secondary criterion may comprise:

$$(P_{4\_2} < TH_{6\_2})$$

and

$$(\nabla P_{4\_2} > V)$$

**[0167]** The sixth criteria set may comprise a sixth tertiary criterion, wherein the sixth tertiary criterion may comprise:

$$(P_{4\_3} < TH_{6\_3})$$

and

$$(\nabla P_{4\_3} > V)$$

**[0168]** Wherein  $P_{4\_1}$  is a fourth primary parameter based on the fourth parameter data and indicative of the resistance between the fourth electrode pair,  $P_{4\_2}$  is a fourth secondary parameter indicative of the resistance between the fourth electrode and the fifth electrode,  $P_{4\_3}$  is a fourth tertiary parameter indicative of the resistance between the fifth electrode pair (fifth electrode and ground electrode) and  $TH_{6\_1}$  is a sixth primary threshold value,  $TH_{6\_2}$  is a sixth secondary threshold value  $TH_{6\_3}$  is a sixth tertiary threshold value, and  $\nabla P_{4\_1}$  is gradient of  $P_{4\_1}$ ,  $\nabla P_{4\_2}$  is gradient of  $P_{4\_2}$ ,  $\nabla P_{4\_3}$  is gradient of  $P_{4\_3}$ , and  $V$  is a gradient limit (e.g. 80%). In one or more exemplary embodiments, the sixth primary threshold value  $TH_{6\_1}$  may correspond to an upper resistance threshold value. In one or more exemplary embodiments,  $TH_{6\_2}$  may correspond to an upper resistance threshold value. In one or more exemplary embodiments,  $TH_{6\_3}$  may correspond to an upper resistance threshold value. An upper resistance threshold value may be set to a value which is less than 30 Mega-Ohms, such as 25 Mega-Ohms, such as 20.5 Mega-Ohms, such as 20.4 Mega-Ohms. The sixth operating state may refer to presence of output detected by the fourth parameter data indicating a sudden leak, e.g. a developing leak. In one or more exemplary embodiments, when the time  $T$  is below  $X$  minutes from the placement of the base plate, where  $X$  is between 5 to 60 minutes, and when any of  $P_{1\_1}$ ,  $P_{2\_1}$ ,  $P_{3\_1}$  in average over  $T$  are below a default threshold value corresponding to an upper resistance threshold value, this indicates that any of the first electrode pair, the second electrode pair, and the third electrode pair is cut (e.g. cut by the user when preparing the base plate for placement around the stoma). In one or more exemplary embodiments, when the time  $T$  is below  $X$  minutes from the

placement of the base plate, where X is between 5 to 60 minutes, and when any of P\_4\_1, P\_4\_2, P\_4\_3 in average over T are below a default threshold value corresponding to an upper resistance threshold value, this indicates an instant leakage, e.g. presence of output on the proximal side.

**[0169]** In one or more exemplary embodiments, any of the first criteria set, the second criteria set, the third criteria set, the fourth criteria set, the default criteria set, the fifth criteria set, the sixth criteria set may be used to define one or more further criteria sets, and thereby to determine one or more operating states.

**[0170]** In one or more exemplary embodiments, different criteria sets may be used to determine the same operating state.

**[0171]** The monitor device comprises a monitor device housing optionally made of a plastic material. The monitor device housing may be an elongate housing having a first end and a second end. The monitor device housing may have a length or maximum extension along a longitudinal axis in the range from 1 cm to 15 cm. The monitor device housing may have a width or maximum extension perpendicular to the longitudinal axis in the range from 0.5 cm to 3 cm. The monitor device housing may be curve-shaped.

**[0172]** The monitor device comprises a first interface. The first interface may be configured as an appliance interface for electrically and/or mechanically connecting the monitor device to the ostomy appliance. Thus, the appliance interface is configured to electrically and/or mechanically couple the monitor device and the ostomy appliance. The first interface may be configured as an accessory device interface for electrically and/or mechanically connecting the monitor device to an accessory device, such as a docking station. The first interface may be configured for coupling to a docking station of the ostomy system, e.g. for charging the monitor device and/or for data transfer between the monitor device and the docking station.

**[0173]** The first interface of the monitor device may comprise a plurality of terminals, such as two, three, four, five, six, seven or more terminals, for forming electrical connections with respective terminals and/or electrodes of the ostomy appliance. One or more terminals of the first interface may be configured for forming electrical connections with an accessory device, e.g. with respective terminals of a docking station. The first interface may comprise a ground terminal. The first interface may comprise a first terminal, a second terminal and optionally a third terminal. The first interface may comprise a fourth terminal and/or a fifth terminal. The first interface optionally comprises a sixth terminal. In one or more exemplary monitor devices, the first interface has M terminals, wherein M is an integer in the range from 4 to 8.

**[0174]** The first interface of the monitor device may comprise a coupling part (may alternatively be denoted a device coupling part or a monitor device coupling part) for forming a mechanical connection, such as a releasable coupling between the monitor device and the base plate. The coupling part and the terminals of the first interface form (at least part of) a first connector of the monitor device.

**[0175]** The monitor device comprises a power unit for powering the monitor device. The power unit may comprise a battery. The power unit may comprise charging circuitry connected to the battery and terminals of the first interface for charging the battery via the first interface, e.g. the first connector. The first interface may comprise separate charging terminal(s) for charging the battery.

**[0176]** The monitor device may comprise a sensor unit with one or more sensor. The sensor unit is connected to the processor for feeding sensor data to the processor. The sensor unit may comprise an accelerometer for sensing acceleration and provision of acceleration data to the processor. The sensor unit may comprise a temperature sensor for provision of temperature data to the processor.

**[0177]** The monitor device comprises a second interface connected to the processor. The second interface may be configured as an accessory interface for connecting, e.g. wirelessly connecting, the monitor device to one or more accessory devices. The second interface may comprise an antenna and a wireless transceiver, e.g. configured for wireless communication at frequencies in the range from 2.4 to 2.5 GHz. The wireless transceiver may be a Bluetooth transceiver, i.e. the wireless transceiver may be configured for wireless communication according to Bluetooth protocol, e.g. Bluetooth Low Energy, Bluetooth 4.0, Bluetooth 5. The second interface optionally comprises a loudspeaker and/or a haptic feedback element for provision of an audio signal and/or haptic feedback to the user, respectively.

**[0178]** In one or more exemplary ostomy systems, the monitor device forms an integrated part of the ostomy appliance, e.g. the monitor device may form an integrated part of a base plate of the ostomy appliance.

**[0179]** The ostomy system may comprise a docking station forming an accessory device of the ostomy system. The docking station may be configured to electrically and/or mechanically couple the monitor device to the docking station.

**[0180]** The docking station may comprise a docking monitor interface. The docking monitor interface may be configured for electrically and/or mechanically connecting the monitor device to the docking station. The docking monitor interface may be configured for wirelessly connecting the monitor device to the docking station. The docking monitor interface of the docking station may be configured to electrically and/or mechanically couple the docking station and the monitor device.

**[0181]** The docking monitor interface of the docking station may comprise, e.g. as part of a first connector of the docking monitor interface, a coupling part for forming a mechanical connection, such as a releasable coupling between the monitor device and the docking station. The coupling part may be configured to engage with a coupling part of the monitor device for releasably coupling the monitor device to the docking station.

**[0182]** The docking monitor interface of the docking station may comprise, e.g. as part of a first connector of the docking monitor interface, a plurality of terminals, such as two, three, four, five, six, seven or more terminals, for forming electrical connections with respective terminals of the monitor device. The docking monitor interface may comprise a ground terminal. The docking monitor interface may comprise a first terminal and/or a second terminal. The docking station may comprise a third terminal. The docking monitor interface may comprise a fourth terminal and/or a fifth terminal. The docking monitor interface optionally comprises a sixth terminal.

**[0183]** Disclosed is an accessory device for an ostomy system having a monitor device and an ostomy appliance. The ostomy appliance can include a base plate. The accessory device may include a memory, a processor, and an interface coupled to the processor and configured to communicate with the monitor device. The interface can include a display device and is configured to obtain monitor data from the monitor device coupled to the ostomy appliance. The processor is configured to determine an operating state of the ostomy appliance (e.g., operating state of the base plate). The monitor device can transmit a monitor signal comprising monitor data indicative of the operating state of the ostomy appliance (e.g., operating state of the base plate). The operating state of the ostomy appliance (e.g. operating state of the base plate) can be indicative of an operating status of the ostomy appliance (e.g. of an operating state of the base plate). The processor is further configured to determine respective locations of one or more changing rooms based on the operating state, changing rooms location data, changing rooms configuration data, and/or crowd sourced changing room location and configuration data. The changing rooms may include restrooms, private rooms, bathrooms, or any space suitable to replace the ostomy appliance for the user. The base plate can be replaced based on the degree of erosion. Also, the base plate and the ostomy bag can be replaced based on a degree of attrition of the ostomy appliance (e.g., an expiration date). The processor can output to the display device directions to a changing room of the one or more changing rooms. As such, it is advantageous that this accessory device aids the user to readily prepare for replacement of the ostomy appliance with less difficulty and time for improved maintenance operation of the ostomy appliance (so as to reduce the likelihood of leakage due to e.g. a degrading operating state of the base plate).

**[0184]** The present disclosure may be seen to advantageously provide, to the user, a navigation tool to changing rooms in timely manner based on the operating state.

**[0185]** Determining the operating state of the ostomy appliance (e.g. the operating state of the base plate) can include determining an operating state of the base plate. The operating state can be indicative of a degree of erosion of the base plate. Also, the operating state can be indicative of a degree of attrition of the ostomy appliance (e.g., degree of attrition of the base plate).

**[0186]** Determining the operating state of the base plate can also include determining a remaining wear time of the base plate. Also, the remaining wear time can be determined based on a time period that takes the base plate to reach a predetermined degree of radial erosion.

Advantageously, the accessory device can automatically calculate the remaining wear time of the ostomy appliance for the user.

**[0187]** The remaining wear time can be determined based on an expiration date of the base plate and/or the ostomy bag.

**[0188]** The interface can include an input device configured to receive input from a user. The input device can be a keyboard, an interactive screen, a pointing device, and the like for inputting data. The input can include a selection from one or more changing rooms that are available to the user. The changing room is selected based on the selection from the one or more changing rooms by the user via the input device. The accessory device (and/or the interface and/or the processor) may be configured to receive via the input device a selection of the changing room. Also, the input can include a selection of a mode of transportation. The changing room can be selected based on the selection of the mode of transportation by the user via the input device. The mode of transportation may include any means of transportation. The accessory device may be configured to receive via the input device a selection of the mode of transportation and to determine the changing room based on the selected mode of transportation.

**[0189]** The interface can be configured to receive one or more configuration criteria from the user of the accessory device. The configuration criteria can represent one or more user preferences. The configuration criteria may comprise one or more of: a name, a type, a distance, a mode of transportation, an estimated time of arrival, a ranking, handicap accessibility, and the like. The processor can be further configured to determine whether the one or more changing rooms satisfy the one or more configuration criteria, and configured to output to the display device an indication in accordance with the determination that the one or more changing rooms satisfy the one or more configuration criteria. The processor can instruct the display device to display the indication and at least a portion of the configuration criteria. Advantageously, the accessory device can display only the changing rooms that satisfy at least a portion of the configuration criteria or all of the configuration criteria. Once the configuration criteria are inputted by the user via the input device, the processor automatically determines which changing rooms satisfy the configuration criteria.

**[0190]** The processor can be further configured to obtain a ranking of the one or more changing rooms and to determine whether the one or more changing rooms meet or exceed a threshold ranking. The ranking can be a star-based system or any other suitable ranking system. The ranking threshold may be comprised in the one or more configuration criteria. It is advantageous that when the user requests changing rooms with at least 3 stars, the processor automatically selects the changing rooms with 3 or more stars rated by the user or other users. Also, the one or more configuration criteria can include changing rooms that are handicap accessible.

**[0191]** The processor can be configured to determine a location of the accessory device and the changing room that is closest to the location of the accessory device from the one or more

changing rooms. The processor can utilize a positioning device (e.g., GNSS) to determine a position of the accessory device, and determine which changing room is located closest to the accessory device position. The accessory device may comprise the positioning device and/or customized stoma map application. As such, without having the user look up a geographical map, the processor automatically calculates relative distances from all available changing rooms to determine the closest changing room to the user. The processor can also be configured to receive a future location of the user and determine respective locations of the one or more changing rooms based on the future locations. The processor can access calendar data of the user and review future appointments within a predetermined time period. The processor can then determine respective locations of the changing rooms based on the future locations associated with the appointments.

**[0192]** Also disclosed is a method of operating an accessory device for an ostomy system having a monitor device and an ostomy appliance. The ostomy appliance can include a base plate. The method includes determining an operating state of the ostomy appliance (e.g., operating state of the base plate). The operating state of the ostomy appliance can be indicative of an operating status of the ostomy appliance (e.g., operating status of the base plate). The method can also include determining respective locations of one or more changing rooms based on the operating state. Depending on the operating state of the ostomy appliance, an appropriate time and/or an appropriate location of the changing room are determined to replace the ostomy appliance. The method can also include providing directions to a changing room of the one or more changing rooms. Direction information to the changing room can be displayed on the display device to guide the user.

**[0193]** To determine the operating state of the ostomy appliance, the method can include determining an operating state of the base plate. The operating state of the base plate can be determined based on a degree of erosion of the base plate.

**[0194]** Determining the operating state of the base plate can include determining a remaining wear time of the base plate. Also, the remaining wear time can be determined based on a time period that takes the base plate to reach a predetermined degree of radial erosion.

**[0195]** The remaining wear time can be determined based on an expiration date of the base plate and/or the ostomy bag.

**[0196]** The method can further include receiving an input and the one or more changing rooms can be selected based on the received input. The input can include a selection from one or more changing rooms that are available to the user. Also, the input can include a selection of a mode of transportation. Further, the input can include one or more configuration criteria, such as a name, a type, a distance, a mode of transportation, an estimated time of arrival, a ranking, handicap accessibility, and the like.

**[0197]** One or more computer-readable media have computer-executable instructions embodied thereon. The computer-executable instructions are configured to cause at least one



processor, upon being executed by the at least one processor, to perform any of the methods related to the accessory device and methods for selecting one or more changing rooms described above.

**[0198]** Fig. 1 illustrates an exemplary ostomy system. The ostomy system 1 comprises an ostomy appliance 2 including a base plate 4 and an ostomy pouch (not shown). Further, the ostomy system 1 comprises a monitor device 6 and an accessory device 8 (mobile telephone). The base plate 4 and the monitor device 6 are in a coupled state, and the monitor device 6 is connectable to the base plate 4 via respective first connectors of the monitor device 6 and base plate 4. The monitor device 6 is configured for wireless communication with the accessory device 8. Optionally, the accessory device 8 is configured to communicate with a server device 10 of the ostomy system 1, e.g. via network 12. The server device 10 may be operated and/or controlled by the ostomy appliance manufacturer and/or a service centre. Ostomy data or parameter data based on the ostomy data are obtained from electrodes/sensors of the ostomy appliance 2 with the monitor device 6. The monitor device 6 processes the ostomy data and/or parameter data based on the ostomy data to determine monitor data that are transmitted to the accessory device 8. The monitor data may include sensor data of the monitor device. In the illustrated ostomy system, the accessory device 8 is a mobile phone or smartphone, however the accessory device 8 may be embodied as another handheld device, such as a tablet device, or a wearable, such as a watch or other wrist-worn electronic device. Accordingly, the monitor device 6 is configured to determine and transmit monitor data to the accessory device 8. The base plate 4 comprises a coupling member 14 in the form of a coupling ring 16 for coupling an ostomy pouch (not shown) to the base plate (two-part ostomy appliance). The base plate 4 has a stoma-receiving or stomal opening 18 with a stoma center point 19. The size and/or shape of the stomal opening 18 is typically adjusted by the user or nurse before application of the ostomy appliance to accommodate the user's stoma.

**[0199]** The ostomy system 1 optionally comprises a docking station 20 forming an accessory device of the ostomy system 1. The docking station 20 comprises a docking monitor interface including a first connector 22 configured for electrically and/or mechanically connecting the monitor device 6 to the docking station 20. The docking monitor interface may be configured for wirelessly connecting the monitor device to the docking station. The docking station 20 comprises a user interface 24 for receiving user input and/or providing feedback to the user on the operational state of the docking station 20. The user interface 24 may comprise a touch-screen. The user interface 24 may comprise one or more physical buttons and/or one or more visual indicators, such as light emitting diodes,

**[0200]** Fig. 2 is a schematic block diagram of an exemplary monitor device. The monitor device 6 comprises a monitor device housing 100, a processor 101 and one or more interfaces, the one or more interfaces including a first interface 102 (appliance interface) and a second interface 104 (accessory interface). The monitor device 6 comprises a memory 106 for storing ostomy data and/or parameter data based on the ostomy data. The memory 106 is connected to the processor 101 and/or the first interface 102.

**[0201]** The first interface 102 is configured as an appliance interface for electrically and/or mechanically connecting the monitor device 6 to the ostomy appliance, e.g. ostomy appliance 2. The first interface 102 comprises a plurality of terminals for forming electrical connections with respective terminals of the ostomy appliance 2 (base plate 4). The first interface 102 comprises a ground terminal 108, a first terminal 110, a second terminal 112 and a third terminal 114. The first interface 102 optionally comprises a fourth terminal 116 and a fifth terminal 118. The first interface 102 of the monitor device 6 comprises a coupling part 120 for forming a mechanical connection, such as a releasable coupling between the monitor device and the base plate. The coupling part 120 and the terminals 108, 110, 112, 114, 116, and 118 of the first interface 102 form (at least part of) a first connector of the monitor device 6.

**[0202]** The monitor device 6 comprises a power unit 121 for powering the monitor device and active components thereof, i.e. the power unit 121 is connected to the processor 101, the first interface 102, the second interface 104, and memory 106. The power unit comprises a battery and charging circuitry. The charging circuitry is connected to the battery and terminals of the first interface 102 for charging the battery via terminals of the first interface, e.g. terminals of the first connector.

**[0203]** The second interface 104 of monitor device is configured as an accessory interface for connecting the monitor device 6 to one or more accessory devices such as accessory device 8. The second interface 104 comprises an antenna 122 and a wireless transceiver 124 configured for wireless communication with accessory device(s). Optionally, the second interface 104 comprises a loudspeaker 126 and/or a haptic feedback element 128 for provision of respective audio signal and/or haptic feedback to the user.

**[0204]** The monitor device 6 optionally comprises a sensor unit 140 connected to the processor 101 for provision of sensor data 142 to the processor 101. The sensor unit 140 comprises a first sensor 144 being a temperature and humidity sensor for feeding temperature and humidity data as sensor data 142 to the processor 101. Further, the sensor unit 140 comprises a second sensor 146 being an accelerometer for feeding acceleration data as sensor data 142 to the processor 101. The processor 101 receives and stores sensor data 142 comprising temperature data, humidity data, and acceleration data, in the memory 106 and/or transmits the sensor data as part of monitor data via second interface 104.

**[0205]** The monitor device 100 is configured to obtain ostomy data from the base plate coupled to the first interface 102. The ostomy data may be stored in the memory 106 and/or processed in the processor 101 in order to obtain parameter data based on the ostomy data.

**[0206]** The monitor device 6 comprises a sensor unit 140 connected to the processor 101. The sensor unit 140 comprises a temperature sensor for feeding temperature data to the processor and a G-sensor or accelerometer for feeding acceleration data to the processor 101.

**[0207]** The processor 101 is configured to apply a processing scheme, and the first interface

102 is configured for collecting ostomy data from the base plate coupled to the first interface, the ostomy data comprising first ostomy data from a first electrode pair of the base plate, second ostomy data from a second electrode pair of the base plate, and third ostomy data from a third electrode pair of the base plate. The ostomy data may be stored in the memory 106 and/or processed in the processor 101 in order to obtain parameter data. The parameter data may be stored in the memory 106. The processor 101 is configured to apply a processing scheme, wherein to apply a processing scheme comprises obtain first parameter data based on the first ostomy data; obtain second parameter data based on the second ostomy data; obtain third parameter data based on the third ostomy data. In other words, the processor 101 is configured to obtain first, second and third parameter data based on respective first, second and third ostomy data. To apply a processing scheme comprises to determine an operating state of the base plate of the ostomy appliance based on one or more, e.g. all, of the first parameter data, the second parameter data and the third parameter data, wherein the operating state is indicative of a degree of radial erosion of the base plate and/or acute leakage risk for the ostomy appliance. The monitor device 6 is configured to, in accordance with a determination that the operating state is a first operating state, transmit a first monitor signal comprising monitor data indicative of the first operating state of the base plate via the second interface; and in accordance with a determination that the operating state is a second operating state, transmit a second monitor signal comprising monitor data indicative of the second operating state of the base plate via the second interface.

**[0208]** Fig. 3 illustrates an exploded view of an exemplary base plate of an ostomy appliance. The base plate 4 comprises a first adhesive layer 200 with a stomal opening 18A. During use, a proximal surface of the first adhesive layer 200 adheres to the user's skin in the peristomal area and/or to additional seals, such as sealing paste, sealing tape and/or sealing ring. The base plate 4 optionally comprises a second adhesive layer 202 with a stomal opening 18B. The base plate 4 comprises a plurality of electrodes arranged in an electrode assembly 204. The electrode assembly 204 is arranged between the first adhesive layer 200 and the second adhesive layer 202. The electrode assembly 204 comprises a support layer with stomal opening 18C and electrodes formed on a proximal surface of the support layer. The base plate 4 comprises a release liner 206 that is peeled off by the user prior to applying the base plate 4 on the skin. The base plate 4 comprises a top layer 208 with a stomal opening 18D and a coupling ring 209 for coupling an ostomy pouch to the base plate 4. The top layer 208 is a protective layer protecting the second adhesive layer 202 from external strains and stress during use.

**[0209]** The base plate 4 comprises a monitor interface. The monitor interface is configured for electrically and/or mechanically connecting the ostomy appliance (base plate 4) to the monitor device. The monitor interface of the base plate comprises a coupling part 210 for forming a mechanical connection, such as a releasable coupling between the monitor device and the base plate. The coupling part 210 is configured to engage with a coupling part of the monitor device for releasably coupling the monitor device to the base plate 4. Further, the monitor interface of the base plate 4 comprises a plurality of terminal elements respectively forming a plurality of terminals 212 for forming electrical connections with respective terminals of the

monitor device. The coupling part 210 and the terminals 212 form a first connector 211 of the base plate 4. The base plate 4 comprises a first intermediate element 213 on the distal side of the electrode assembly. The first intermediate element 213 is arranged between the terminal elements forming terminals 212 and the first adhesive layer (not shown). The first intermediate element 213 covers the terminal elements forming terminals 212 of the base plate 4 when seen in the axial direction and protects the first adhesive layer from mechanical stress from the terminal elements of the base plate.

**[0210]** Fig. 4 illustrates an exploded view of an exemplary electrode assembly 204 of a base plate. The electrode assembly 204 has a distal side 204A and a proximal side 204B. The electrode assembly 204 comprises a support layer 214 with proximal surface 214B and electrodes 216 arranged on the proximal side of the support layer 214 and including a ground electrode, a first electrode, a second electrode, a third electrode, a fourth electrode, and a fifth electrode, wherein each electrode has a respective connection part 217 for connecting the electrodes 216 to respective terminal elements of the monitor interface. The electrodes 216 are positioned and/or formed on a proximal side 214B of the support layer 214. Further, electrode assembly 204 comprises a masking element 218 with proximal surface 218B and configured to insulate electrode parts of electrodes 216 from the first adhesive layer of the base plate. The masking element 218 covers or overlap with parts of the electrodes 216 when seen in the axial direction.

**[0211]** Fig. 5 is a proximal view of proximal surfaces of base plate parts of the base plate without the first adhesive layer and the release liner. The base plate 4 comprises a first intermediate element 213 on the distal side of the electrode assembly, i.e. between the electrode assembly 204 and the first adhesive layer (not shown). The first intermediate element 213 covers the terminal elements of the base plate 4 when seen in the axial direction and protects the first adhesive layer from mechanical stress from the terminal elements of the base plate.

**[0212]** Fig. 6 is a distal view of an exemplary electrode configuration 220 of electrodes 216 of the electrode assembly 204. The electrode configuration 220/electrode assembly 204 comprises a ground electrode 222, a first electrode 224, a second electrode 226, a third electrode 228, a fourth electrode 230, and a fifth electrode 232. The ground electrode 222 comprises a ground connection part 222A and the first electrode 224 comprises a first connection part 224A. The second electrode 226 comprises a second connection part 226A and the third electrode 228 comprises a third connection part 228A. The fourth electrode 230 comprises a fourth connection part 230A and the fifth electrode 232 comprise a fifth connection part 232A.

**[0213]** The fourth electrode 230 comprises fourth sensing parts 230B. The fifth electrode 232 comprises fifth sensing parts 232B.

**[0214]** The ground electrode 222 comprises a first electrode part 234 for forming a ground or reference for the first electrode 224. The ground electrode 222 comprises a second electrode

part 236 for forming a ground or reference for the second electrode 226. The ground electrode 222 comprises a third electrode part 238 for forming a ground or reference for the third electrode 228. The masking element 218 is arranged proximal to the electrodes 222, 224, 226, 228 covering and insulating parts of the electrodes from the first adhesive and forming respective conductor parts of the electrodes 222, 224, 226, 228. The parts of the electrodes 222, 224, 226, 228 not covered by the masking element 219 contacts the first adhesive layer and form sensing parts 224B, 226B, 228B of electrodes 224, 226, 228, respectively. Further, the electrode parts 234, 236, 238 form sensing parts of the ground electrode 222.

**[0215]** The first sensing part 224B extends circularly at least 330 degrees around the stomal opening at a first radial distance R1 from the center point 19. The first radial distance R1 may be around 14 mm. In one or more embodiments, the first radial distance R1 may be around 13 mm, such as 12.5 mm. The first electrode part 234 is arranged on the inside of the first sensing part (i.e. closer to the center point) and extends circularly at least 330 degrees around the stomal opening at a first ground distance RG1 from the first sensing part (radially from the center point). The first ground distance RG1 between sensing part of first electrode and first electrode part is about 1 mm.

**[0216]** The second sensing part 226B extends circularly at least 330 degrees around the stomal opening at a second radial distance R2 from the center point 19. The second radial distance R2 may be 18 mm. In one or more embodiments, the second radial distance R2 may be 17 mm. The second electrode part 236 is arranged on the inside of the second sensing part 226B (i.e. closer to the center point) and extends circularly at least 330 degrees around the stomal opening at a second ground distance RG2 from the second sensing part 226B (radially from the center point). The second ground distance RG2 between sensing part of second electrode and second electrode part is about 1 mm.

**[0217]** The third sensing part 228B extends circularly at least 330 degrees around the stomal opening at a third radial distance R3 from the center point 19. The third radial distance R3 is about 26 mm. In one or more embodiments, the third radial distance R3 is 21 mm. The third electrode part 238 is arranged on the inside of the third sensing part 228B (i.e. closer to the center point) and extends circularly at least 330 degrees around the stomal opening at a third ground distance RG3 from the third sensing part 228B (radially from the center point). The third ground distance RG3 between sensing part of third electrode and third electrode part is about 1 mm.

**[0218]** The ground electrode 222 comprises a fourth electrode part 240 for forming a ground or reference for the fourth electrode 230 and the fifth electrode 232. The fourth electrode part 240 of the ground electrode 222 extends at least 300 degrees around the stomal opening and comprises ground sensing parts 222B. The fourth sensing parts 230B, fifth sensing parts 232B, and ground sensing parts of the fourth electrode part 240 are circularly distributed around the center point 19 at a leakage radius from the center point (such as a leakage radius R5 which may be around 32 mm from the center point). The fourth sensing parts 230B, fifth sensing parts 232B, and ground sensing parts of the fourth electrode part may have a radial extension

larger than 1.0 mm, such as in the range from 1.5 mm to 3.0 mm, e.g. about 2.0 mm. The fourth sensing parts 230B, fifth sensing parts 232B, and ground sensing parts of the fourth electrode part 240 may have a circumferential extension (perpendicular to the radial extension) larger than 1.0 mm, such as in the range from 2.5 mm to 5.0 mm, e.g. about 3.5 mm.

**[0219]** Fig. 7 is a distal view of an exemplary masking element. The masking element 218 optionally has a plurality of terminal openings including six terminal openings. The plurality of terminal openings comprises a ground terminal opening 242, a first terminal opening 244, a second terminal opening 246, a third terminal opening 248, a fourth terminal opening 250, and a fifth terminal opening 252. The terminal openings 242, 244, 246, 248, 250, 252 of the masking element 218 are configured to overlap and/or be aligned with respective connection parts 222A, 224A, 226A, 228A, 230A, 232A of the electrodes of the electrode assembly.

**[0220]** The masking element 218 has a plurality of sensor point openings. The sensor point openings comprise primary sensor point openings shown within dotted line 254, each primary sensor point opening configured to overlap a part of the ground electrode 222 and/or a part of the fourth electrode 230. The primary sensor point openings 254 comprise, in the illustrated exemplary masking element, five primary first sensor point openings 254A each configured to overlap a part of the ground electrode 222. The primary sensor point openings 254 comprise, in the illustrated exemplary masking element, four primary second sensor point openings 254B each configured to overlap a part of the fourth electrode 230. The sensor point openings comprise secondary sensor point openings shown within dotted line 256, each second sensor point opening configured to overlap a part of the fourth electrode 230 and/or a part of the fifth electrode 232. The secondary sensor point openings 256 comprise, in the illustrated exemplary masking element, five secondary first sensor point openings 256A each configured to overlap a part of the fifth electrode 232. The secondary sensor point openings 256 comprise, in the illustrated exemplary masking element, four secondary second sensor point openings 256B each configured to overlap a part of the fourth electrode 230. The sensor point openings comprise tertiary sensor point openings shown within dotted line 258, each tertiary sensor opening configured to overlap a part of the fifth electrode 232 and/or a part of the ground electrode 222. The tertiary sensor point openings 258 comprise, in the illustrated exemplary masking element, five tertiary first sensor point openings 258A each configured to overlap a part of the fifth electrode 232. The tertiary sensor point openings 258 comprise, in the illustrated exemplary masking element, four tertiary second sensor point openings 258B each configured to overlap a part of the ground electrode 222.

**[0221]** Fig. 8 is a distal view of an exemplary first adhesive layer. The first adhesive layer 200 has a plurality of sensor point openings. The sensor point openings of the first adhesive layer comprise primary sensor point openings shown within dotted line 260, each primary sensor point opening configured to overlap a part of the ground electrode 222 and/or a part of the fourth electrode 230 of the electrode assembly. The primary sensor point openings 260A, 260B comprise, in the illustrated exemplary first adhesive layer, five primary first sensor point openings 260A each configured to overlap a part of the ground electrode 222. The primary sensor point openings 260A, 260B comprise, in the illustrated exemplary first adhesive layer,

four primary second sensor point openings 260B each configured to overlap a part of the fourth electrode 230. The sensor point openings of the first adhesive layer comprise secondary sensor point openings shown within dotted line 262, each second sensor point opening configured to overlap a part of the fourth electrode 230 and/or a part of the fifth electrode 232 of the electrode assembly. The secondary sensor point openings 262A, 262B comprise, in the illustrated exemplary first adhesive layer, five secondary first sensor point openings 262A each configured to overlap a part of the fifth electrode 232. The secondary sensor point openings 262A, 262B comprise, in the illustrated exemplary first adhesive layer, four secondary second sensor point openings 262B each configured to overlap a part of the fourth electrode 230. The sensor point openings of the first adhesive layer comprise tertiary sensor point openings shown within dotted line 264, each tertiary sensor opening configured to overlap a part of the fifth electrode 232 and/or a part of the ground electrode 222 of the electrode assembly. The tertiary sensor point openings 264A, 264B comprise, in the illustrated exemplary first adhesive layer, five tertiary first sensor point openings 264A each configured to overlap a part of the fifth electrode 232. The tertiary sensor point openings 262A, 262B comprise, in the illustrated exemplary first adhesive layer, four tertiary second sensor point openings 264B each configured to overlap a part of the ground electrode 222. Fig. 9 is a proximal view of the first adhesive layer of Fig. 8.

**[0222]** Fig. 10 is a more detailed distal view of a part of the base plate 4. Monitor interface of the base plate comprises the first connector 211. The first connector 211 comprises coupling part 210 configured to releasably couple the monitor device to the base plate and thus forming a releasable coupling. The first connector 211/monitor interface comprises a plurality of terminals formed by respective terminal elements for forming respective electrical connections with respective terminals of the monitor device.

**[0223]** The plurality of terminals of the first connector 211/monitor interface comprises a ground terminal element 282 forming a ground terminal 282A, a first terminal element 284 forming a first terminal 284, a second terminal element 286 forming a second terminal 286A, and optionally a third terminal element 288 forming a third terminal 288A. The monitor interface optionally comprises a fourth terminal element 290 forming a fourth terminal 290A and/or a fifth terminal element 292 forming a fifth terminal 290. The terminal elements 282, 284, 286, 288, 290, 292 contact respective connection parts 222A, 224A, 226A, 228A, 230a, 232A of electrodes 222, 224, 226, 228, 230, 232.

**[0224]** Fig. 11 is an illustrative block diagram representing the accessory device 8 configured to perform a changing room selection process to provide one or more navigational directions to one or more changing rooms for a user of the ostomy appliance 2. The changing rooms can be restrooms, private rooms, bathrooms, or any space suitable to replace the ostomy appliance 2 for the user. It may be seen that the accessory device 8 is configured to provide assistance in navigating the user to a selected changing room for replacing at least a portion of the ostomy appliance 2. It is advantageous that this changing room selection process aids the user to readily identify changing rooms available for the user. The accessory device 8 has peripheral devices, such as a processor 300, a memory 302, a positioning device, such as a

global navigation satellite system (GNSS), 304, an input device 306, such as a keyboard, at least one display device 308A, 308B, 308C (collectively 308), and an interface 310. Peripheral devices 302, 304, 306, 308, 310 can be operatively and communicably coupled to the processor 300 via a bus 312 for transmitting and receiving data. The processor 300 can be a central processing unit (CPU), but other suitable microprocessors are also contemplated.

**[0225]** The positioning device 304 generates positional information of the accessory device 8 and one or more changing rooms available to the user using a positional signal. The positional signal can be received from a GNSS satellite. The input device 306 can be a keyboard or an interactive screen for inputting data, such as alphabetical and/or numerical characters. Input data can be temporarily or permanently stored in the memory 302 or any other suitable database. The display device 308 can be a touch screen or a monitor, or the like.

**[0226]** The interface 310 is operatively coupled to the processor 300 and configured to communicate with the monitor device 6. The interface 310 can include the display device 308 and can be configured to obtain monitor data 314 from the monitor device 6 that is coupled to the ostomy appliance 2. Data processed by units 6, 300, 304, 306, 308 can also be stored in the memory 302. Operating state data 316, configuration criteria data 318, ranking data 320, and location data 322 are stored in the memory 302 for subsequent processing.

**[0227]** Further included in the processor 300 are an operating state determination unit 324, a location determination unit 326, and a selections output unit 328. Units 324, 326, 328 can be mutually communicable via the bus 310 for processing relevant data. Detailed descriptions of the units 324, 326, 328 and data 316, 318, 320, 322 are provided below in paragraphs related to Figs. 12-19.

**[0228]** Fig. 12 shows that the one-part ostomy appliance 2 having an ostomy bag 330 is being applied to a stoma 332 of the user. In this configuration, the base plate 4 is fixedly attached to the ostomy bag 330. Fig. 13 shows that the two-part ostomy appliance 2 having the ostomy bag 330 and the base plate 4. In this configuration, the base plate 4 is separable from the ostomy bag 330. In Fig. 13, the base plate 4 includes a release liner 206 that can be peeled off by the user prior to applying the base plate 4 on the skin. A distal surface 206A of the release liner 206 can be attached to the user.

**[0229]** The operating state determination unit 324 is configured to determine an operating state of the ostomy appliance 2 (e.g. operating state of the base plate 4). The operating state of the ostomy appliance 2 can be indicative of an operating status of the ostomy appliance 2, such as of the base plate 4 and/or the ostomy bag 330. The monitor device 6 is configured to transmit a monitor signal comprising monitor data 314 indicative of the operating state of the ostomy appliance 2. Initially, the operating state of the ostomy appliance 2 may be indicative of a default or normal operating state of the base plate 4 wherein the default operating state is indicative of very low or no degree of radial erosion of the base plate 4. After the prolonged use of the ostomy appliance 2, the operating state of the ostomy appliance 2 may be indicative of a degree of radial erosion of the base plate 4, such as of the first adhesive layer 200, and/or



indicative of an acute leakage risk of the ostomy appliance 2.

**[0230]** As discussed above, the operating state can include a first operating state indicative of the base plate 4 corresponding to a situation wherein the first adhesive layer 200 has experienced a first degree of radial erosion, a second operating state indicative of the base plate 4 corresponding to a situation wherein the first adhesive layer 200 has experienced a second degree of radial erosion, a third operating state indicative of the base plate 4 corresponding to a situation wherein the first adhesive layer 200 has experienced a third degree of radial erosion. Further, the operating state can include a fourth operating state indicative of the base plate 4 corresponding to a situation wherein a leakage sensor 334 attached to the base plate 4 detects a presence of fluid, such as output, between the skin of the user and a distal surface of first adhesive layer 200, indicating that a high risk of leakage from the ostomy appliance 2.

**[0231]** Further, the operating state can include an eighth operating state indicative of a degree of attrition of the base plate 4 based on an expiration date of the base plate 4. Based on the seventh operating state, the operating state determination unit 324 can determine a remaining wear time of the ostomy bag 330. Also, based on the eighth operating state, the operating state determination unit 324 can determine a remaining wear time of the base plate 4.

**[0232]** However, the remaining wear time of the base plate 4 can also be determined based on a time period that takes the base plate 4 to reach a predetermined degree of radial erosion.

**[0233]** Depending on the operating state of the ostomy appliance 2, the location determination unit 326 can determine an appropriate time to replace the ostomy appliance 2 and/or an appropriate location of the changing room. If the operating state of the base plate 4 is at the first operating state, there is more time for the user to prepare for the replacement of the base plate 4 than at the third operating state. Thus, the location determination unit 326 can select the changing rooms that are preferred by the user but located farther away (or take longer time to reach) from the accessory device 8. Thus, the location determination unit 326 can select the changing rooms that are preferred by the user but located farther away (or take longer time to reach) from the accessory device 8.

**[0234]** The operating state determination unit 324 is configured to receive the monitor data 314 indicative of one or more of the above operating states relating to the base plate 4, and generate the operating state data 316 based on the monitor data 314. The operating state determination unit 324 can store the operating state data 316 for subsequent retrieval by other units, such as the location determination unit 326.

**[0235]** The location determination unit 326 is configured to determine respective locations of one or more changing rooms based on the operating state of the ostomy appliance 2. The location determination unit 326 can retrieve the operating state data 316 from the memory 302 or directly from the operating state determination unit 324. When the operating state of the ostomy appliance 2 is indicative of the default or normal operating states of the base plate 4,

the location determination unit 326 typically does not perform the changing room selection process. However, the location determination unit 326 can perform the changing room selection process in anticipation of an upcoming or future operating state that requires replacement of at least a portion of the ostomy appliance 2. In case of the one-part ostomy appliance 2, both the base plate 4 and the ostomy bag 330 are simultaneously replaced. In case of the two-part ostomy appliance 2, at least one of the base plate 4 and the ostomy bag 330 is replaced as desired based on the operating state of the ostomy appliance 2.

**[0236]** Fig. 14 shows an exemplary user interface screen illustrating changing room selection process performed by the location determination unit 326 and via the display device 308. The location determination unit 326 can be configured to receive input from the user using the input device 306. As discussed above, the interface 310 can include the input device 306, such as a push button or touch screen, which is configured to receive the input from the user. The received input can be communicably transmitted to the location determination unit 326 to determine which changing room is appropriate for the user. The input can include a selection from one or more changing rooms that are available to the user. Using the positioning device 304, the location determination unit 326 can generate a list of available changing rooms based on the location data 322. The location data 322 can include location information relating to a current location of the accessory device 8 and relative positions of changing rooms available within a predetermined distance (e.g., less than 2 kilometres or 1.2 miles) from the current location of the accessory device 8.

**[0237]** In Fig. 14, the location determination unit 326 can provide data for display at least a portion of the list of available changing rooms (Name) A, B, and X on the display device 308. The display device 308 can also display selection boxes (Select) 338 corresponding to the available changing rooms A, B, and X. Each selection box 338 can be selected (e.g., clicked, touched, acted upon, ticked, tapped) by the user using the input device 306 to select one of the changing rooms A, B, and X. Other selection methods, such as selected (e.g., clicked, touched, acted upon, ticked, tapped) on a name 340 of the changing room, can be employed to suit different applications. Further, the changing room can be selected based on other inputs, such as a mode of transportation (MOT) 342 by the user via the input device 306. The MOT 342 can include any means of transportation, such as "on foot," "bus," "car," "train," "boat," and the like. When the user prefers to walk, the changing room A is selected by the user. Other inputs, such as a type of establishment (Type) 344, a distance between the accessory device 8 and the changing room (Distance) 346, and an estimated time of arrival (ETA) 348, are also contemplated to suit the application. The Type 344 can include a hotel type, a portable unit type, a restaurant type, a park type, a mall type, and the like.

**[0238]** Selecting one of the changing rooms A, B, and X can be made manually by the user using the input device 306 or automatically made by the location determination unit 326 based on one or more of the inputs made by the user. If only the ostomy bag 330 is to be replaced, the location determination unit 326 may select the changing room X having a portable unit type. If the entire ostomy appliance 2 is to be replaced, the location determination unit 326 may select the changing room A having a hotel type, where appropriate cleaning and private

facilities are provided. Other suitable arrangements based on the distance and the ETA are also contemplated.

**[0239]** Fig. 15 shows an exemplary user interface illustrating configuration criteria that can be entered by the user for the changing room selection process. The location determination unit 326 can utilize the interface 310 that is configured to receive one or more configuration criteria from the user of the accessory device 8. The configuration criteria can represent one or more user preferences in the changing room selection process. The configuration criteria may comprise a name, a type, a distance, a mode of transportation, an estimated time of arrival, a ranking, handicap accessibility, and the like. More specifically, in Fig. 15, the user can enter a preferred name 340' of the changing room A or select the preferred name 340' of the changing room A from a predetermined changing room list. The location determination unit 326 can also automatically select the preferred name 340' retrieved from historical data, such as the ranking data 320, saved in the memory 302 based on a previous experience of the user at the selected changing room.

**[0240]** The user can also enter other configuration criteria, such as a preferred type 344', to select only changing rooms having, for example, a hotel type. Other types, such as the portable unit type and the park type, can be entered as desired. Also, a preferred distance 346' can be entered to select only changing rooms that are located, for example, within 1 kilometre from the user. Other suitable distance can be entered by the user. A preferred mode of transportation 342' can be entered to select only changing rooms that can be reached, for example, by a bus. Other suitable modes of transportation, such as a taxi and train, can be entered. A preferred estimated time of arrival 348' can be entered to select only changing rooms that the user can arrive, for example, within 30 minutes. Other suitable ETA can be entered as desired.

**[0241]** Further, the location determination unit 326 can be configured to determine a current location of the accessory device 8. Using the positioning device 304, the location determination unit 326 can determine the current location of the user having the accessory device 8. The location determination unit 326 can store the location data 322 having location information relating to the current location of the accessory device 8 and relative positions of changing rooms available within a predetermined distance (e.g., less than 2 kilometres or 1.2 miles) from the current location of the accessory device 8. The location determination unit 326 can then determine the changing room that is closest to the location of the accessory device 8. The location determination unit 326 can provide the location information about the closest changing room to the user when the ostomy appliance 2 is to be replaced immediately.

**[0242]** When the ostomy appliance 2 does not have to be replaced immediately, the location determination unit 326 can receive one or more future locations of the user and determine respective locations of the changing rooms based on the one or more future locations of the user. If the user is to attend a meeting at a specific location and at specific date and time in the near future, the user can enter the specific location with the date and time information of the meeting using the input device 306. The location determination unit 326 can provide the

location information about the closest changing room from the specific location of the meeting based on the date and time information.

**[0243]** For example, if the user is attending a meeting at a location A at 3 o'clock in the afternoon, the location determination unit 326 provides the location information about the closest changing room that can be reached from the location A by 2:45 p.m. at the latest so that the user has time to replace the ostomy appliance 2 before the 3 o'clock meeting. Alternatively or additionally, the location determination unit 326 can provide for display the location information about two or more changing rooms in the vicinity of the one or more future locations. The user can manually select one of the two or more changing rooms displayed on the display device 308, or the location determination unit 326 can automatically select one of the two or more changing rooms based on the configuration criteria.

**[0244]** Fig. 16 shows the memory 302 having calendar data 350 with one or more future appointment A 352A, appointment B 352B, and appointment X 352X, collectively designated 352. The calendar data 350 can also be obtained by a third party application accessing the calendar data 350 stored in an external database. In Fig. 16, each appointment 352A, 352B, 352X includes future location information including date, time, and address data. The location determination unit 326 can access the calendar data 350 stored in the memory 302 and review the future appointments 352 of the calendar data 350 within a predetermined time period to determine the future locations of the user with respect to the current location of the accessory device 8. The location determination unit 326 can then determine respective locations of the changing rooms based on the future locations associated with the future appointments 352.

**[0245]** Fig. 17 shows an exemplary user interface with other illustrative configuration criteria that can be entered by the user for the changing room selection process. The configuration criteria can include a ranking 354 of each changing room. The ranking 354 can be part of a star-based system where a number of stars associated with each changing room represent a degree of satisfaction by the user or other users. Other suitable ranking systems, such as a letter-grade system, are also contemplated to suit the application. The location determination unit 326 can be further configured to obtain the ranking 354 of each changing room A, B, and X. The location determination unit 326 can obtain the ranking 354 from an external source, such as a social media or another application (e.g., Wheelmate), that provides to the display device for display ranking information about the changing rooms based on previous experiences of other users of the ostomy appliance 2.

**[0246]** Also, the user can enter the user's own ranking 354 of each changing room based on a personal experience of the user. The ranking 354 can include a score (e.g., an alphanumeric or symbolic indicator). Each ranking 354 can include a weighting factor used in calculation of the score based on a priority level set by the user. Other ranking algorithms, such as a regularized least-squares based ranking and a click-through history ranking, are also contemplated to suit different applications.

**[0247]** The location determination unit 326 can store the ranking information in the memory

302 as the ranking data 320. The ranking data 320 can be subsequently retrieved by the location determination unit 326 or other systems for further processing. The location determination unit 326 can determine whether the one or more changing rooms A, B, and X meet or exceed a threshold ranking (e.g., 3 stars or more). The threshold ranking can be entered by the user as part of the configuration criteria.

**[0248]** The configuration criteria can also include changing rooms that are handicap accessible. In Fig. 16, the user can enter a handicap accessible option 356 of "Yes" to select only changing rooms that provide wheelchair accessibility. Any of the configuration criteria (e.g., access to water, accessibility to empty the bag without kneeling on the floor, handicap accessible toilets, etc.) can be manually entered by the user in real time or automatically selected by the location determination unit 326 based on a predetermined policy set by the user. The predetermined policy can include default values of the configuration criteria. The location determination unit 326 can temporarily or permanently store the entered configuration criteria in the memory 302 as the configuration criteria data 318. The location determination unit 326 can be further configured to determine whether the one or more changing rooms A, B, and X satisfy the one or more configuration criteria based on the configuration criteria data 318.

**[0249]** Fig. 18 shows an exemplary user interface illustrating changing room selection results displayed on the display device 308. After the location determination unit 326 determines which changing rooms A, B, and X satisfy the configuration criteria, the changing room selection results are displayed by the selections output unit 328. The selections output unit 328 can be configured to instruct the display device 308 to display an indication 358 in accordance with the determination that the one or more changing rooms A, B, and X satisfy the one or more configuration criteria. The indication 358 can include a recommendation rank (e.g., first recommendation or second recommendation), a match percentage (e.g., 98% or 75%), or any other symbols or characters representing the satisfaction of the one or more configuration criteria. The selections output unit 328 can also instruct the display device 308 to display direction information 360 to guide the user to a corresponding changing room. Each direction information 360, such as Direction A, Direction B, and Direction X, can be selected (e.g., clicked, touched, acted upon, ticked, tapped) by the user e.g., using the input device 306 to activate a link leading to a directions guide for the corresponding changing room (e.g. opening a navigation application directing the user to the corresponding changing room), such as Changing Room A, Changing Room B, and Changing Room X, respectively.

**[0250]** Fig. 19 illustrates one example of a method 400 for selecting one or more changing rooms for the user of the ostomy appliance 2. It will be described with reference to Figs. 1-18. However, any suitable structure can be employed. Although the sub-blocks 402-412 are illustrated, other suitable sub-blocks can be employed to suit different applications.

**[0251]** In operation, at block 402, the operating state determination unit 324 determines an operating state of the ostomy appliance 2. The operating state determination unit 324 determines the operating state of the base plate 4 to prevent any potential leakage from the

ostomy appliance 2. At block 404, the operating state determination unit 324 determines the operating state of the base plate 4 based on the degree of erosion of the base plate 4. As discussed above, the operating determination unit 324 can determine the first, second, and third operating states based on the degree of radial erosion of the base plate 4. Also, the operating determination unit 324 can determine the fourth operating state using the leakage sensor 334.

**[0252]** At block 406, the operating determination unit 324 can determine a remaining wear time of the base plate. Additionally or alternatively, the operating determination unit 324 can determine the seventh and eighth operating states based on the expiration dates of the ostomy bag 330 and the base plate 4. Based on the expiration dates of the base plate 4, the operating determination unit 324 determines the remaining wear time of the base plate. Also, the operating determination unit 324 can determine the expiration date of the base plate 4 based on the time period to reach the predetermined degree of radial erosion.

**[0253]** At block 408, the location determination unit 326 receives one or more inputs from the user via the input device 306. As shown in Fig. 14, the input device 306, such as a push button, is used to enter a selection made by the user. Selection inputs can include the name 340, the MOT 342, the type 344, the distance 346, and the ETA 348. At block 410, the location determination unit 326 determines respective locations of one or more changing rooms based on the operating state of the ostomy appliance 2 (e.g., operating state of the base plate 4). Depending on the operating state of the ostomy appliance 2, the location determination unit 326 can determine an appropriate time to replace the ostomy appliance 2 and/or an appropriate location of the changing room. At block 412, the selections output unit 328 instructs the display device 308 to display direction information 358 to guide the user to the one or more changing rooms. Other suitable combinations of method steps described above are contemplated.

**[0254]** The above detailed description of the present disclosure and the examples described therein have been presented for the purposes of illustration and description only and not by limitation. It is therefore contemplated that the present disclosure covers any and all modifications, variations or equivalents that fall within the spirit and scope of the basic underlying principles disclosed above and claimed herein.

**[0255]** The position of the first connector on the base plate, the number of terminals and the position of the terminals in the coupling part may be adapted to the electrode configuration used in the electrode assembly of the base plate.

**[0256]** Fig. 20 shows an exemplary graphical representation of parameter data as a function of time. In this example, the parameter data in the y-axis is in Volts and time is in the x-axis. Curve 1100 shows, as a function of time, first parameter data indicative of voltage measured by the first electrode pair of the base plate. Curve 1102 shows, as a function of time, second parameter data indicative of voltage measured by the second electrode pair of the base plate. Curve 1104 shows, as a function of time, third parameter data indicative of voltage measured

by the third electrode pair of the base plate. Curves 1108, 1116, 1118 show, as a function of time, fourth primary parameter indicative of voltage measured by the fourth electrode pair of the base plate, fourth secondary parameter indicative of voltage measured by the fourth electrode and the fifth electrode of the base plate, and fourth tertiary parameter indicative of voltage measured by the fifth electrode pair of the base plate respectively. Curves 1110, 1112, 1114 show, as a function of time, a gradient of fourth primary parameter indicative of voltage gradient measured by the fourth electrode pair of the base plate, a gradient of fourth secondary parameter indicative of voltage gradient measured by the fourth electrode and the fifth electrode of the base plate, and a gradient of fourth tertiary parameter indicative of voltage gradient measured by the fifth electrode pair of the base plate respectively. Fig. 20 shows the upper voltage threshold value represented as curve 1000, the medium voltage threshold value represented as curve 1002, the lower voltage threshold value represented as curve 1004, and curve 1006 is a gradient limit.

**[0257]** Curves 1108, 1116, 1118 as well as curves 1110, 1112, 1114 show that no moisture is detected at the proximal side of the first adhesive layer by the fourth electrode pair.

**[0258]** At a time less than 5h, curve 1100 shows that moisture is detected by the first electrode pair as the first parameter data crosses the upper voltage threshold value while curve 1102 shows that moisture is not detected by the second electrode pair as the second parameter data has not crossed the upper voltage threshold value. At this stage, it is determined that the ostomy appliance is in a first operating state.

**[0259]** At time between 5h and 10h, curve 1102 shows that moisture is detected by the second electrode pair as the second parameter data crosses the upper voltage threshold value. At this stage, it is determined that the ostomy appliance is in a second operating state.

**[0260]** At time around 45h, curve 1104 shows that moisture is detected by the third electrode pair as the third parameter data crosses the upper voltage threshold value. At this stage, it is determined that the ostomy appliance is in a third operating state.

**[0261]** Fig. 21 shows an exemplary graphical representation of parameter data as a function of time. In this example, the parameter data in the y-axis is in Volts and time is in the x-axis. Curve 1202 shows, as a function of time, first parameter data indicative of voltage measured by the first electrode pair of the base plate. Curve 1204 shows, as a function of time, second parameter data indicative of voltage measured by the second electrode pair of the base plate. Curve 1200 shows, as a function of time, third parameter data indicative of voltage measured by the third electrode pair of the base plate. Curves 1206, 1208, 1210 show, as a function of time, fourth primary parameter indicative of voltage measured by the fourth electrode pair of the base plate, fourth secondary parameter indicative of voltage measured by the fourth electrode and the fifth electrode of the base plate, and fourth tertiary parameter indicative of voltage measured by the fifth electrode pair of the base plate respectively. Curves 1212, 1214, 1216 show, as a function of time, a gradient of fourth primary parameter indicative of voltage gradient measured by the fourth electrode pair of the base plate, a gradient of fourth

secondary parameter indicative of voltage gradient measured by the fourth electrode and the fifth electrode of the base plate, and a gradient of fourth tertiary parameter indicative of voltage gradient measured by the fifth electrode pair of the base plate respectively. Fig. 21 shows the upper voltage threshold value represented as curve 1000, the medium voltage threshold value represented as curve 1002, the lower voltage threshold value represented as curve 1004, and curve 1006 represents a gradient limit.

**[0262]** Curves 1206, 1208, 1210 as well as curves 1212, 1214, 1216 show that moisture is detected at the proximal side of the first adhesive layer by the fourth electrode pair, the fourth and fifth electrode, and the fifth electrode pair at a time starting at 60h until 90h. As the three electrode pairs are triggered as shown by the decreases shown by 1206, 1208, 1210 and as the curves 1212, 1214, 1216 show a gradient below 80%, this is indicative of the presence of sweat at the proximal side of the first adhesive layer.

**[0263]** At a time of 30min, curve 1202 shows that moisture is detected by the first electrode pair as the first parameter data crosses the upper voltage threshold value while curve 1204 shows that moisture is not detected by the second electrode pair as the second parameter data has not crossed the upper voltage threshold value. At this stage, it is determined that the ostomy appliance is in a first operating state.

**[0264]** At time around 40h, curve 1204 shows that moisture is detected by the second electrode pair as the second parameter data crosses the upper voltage threshold value. At this stage, it is determined that the ostomy appliance is in a second operating state.

**[0265]** Fig. 22 shows an exemplary graphical representation of parameter data as a function of time. In this example, the parameter data in the y-axis is in Volts and time is in the x-axis. Curve 1300 shows, as a function of time, first parameter data indicative of voltage measured by the first electrode pair of the base plate. Curve 1302 shows, as a function of time, second parameter data indicative of voltage measured by the second electrode pair of the base plate. Curve 1304 shows, as a function of time, third parameter data indicative of voltage measured by the third electrode pair of the base plate. Curves 1306, 1308, 1310 show, as a function of time, fourth primary parameter indicative of voltage measured by the fourth electrode pair of the base plate, fourth secondary parameter indicative of voltage measured by the fourth electrode and the fifth electrode of the base plate, and fourth tertiary parameter indicative of voltage measured by the fifth electrode pair of the base plate respectively. Curves 1312, 1314, 1316 show, as a function of time, a gradient of fourth primary parameter indicative of voltage gradient measured by the fourth electrode pair of the base plate, a gradient of fourth secondary parameter indicative of voltage gradient measured by the fourth electrode and the fifth electrode of the base plate, and a gradient of fourth tertiary parameter indicative of voltage gradient measured by the fifth electrode pair of the base plate respectively. Fig. 22 shows the upper voltage threshold value represented as curve 1000, the medium voltage threshold value represented as curve 1002, the lower voltage threshold value represented as curve 1004, and curve 1006 is a gradient limit.



**[0266]** Curves 1306, 1308, 1310 as well as curves 1312, 1314, 1316 show that moisture is detected at the proximal side of the first adhesive layer by the fourth electrode pair at a time starting at around 25h. As leakage electrodes (i.e. the fourth electrode pair, the fourth and fifth electrode, and the fifth electrode pair) are triggered as shown by the decreases shown by 1306, 1308, 1310 and as curve 1312, 1314, 1316 show a gradient above 80%, this is indicative of the presence of output at the proximal side of the first adhesive layer. This indicates severe leakage. It may be determined that the ostomy appliance is in a sixth operating state.

**[0267]** At a time of 5h, curve 1300 shows that moisture is detected by the first electrode pair as the first parameter data crosses the upper voltage threshold value while curve 1302 shows that moisture is not detected by the second electrode pair as the second parameter data has not crossed the upper voltage threshold value. At this stage, it is determined that the ostomy appliance is in a first operating state.

**[0268]** At time around 15h, curve 1302 shows that moisture is detected by the second electrode pair as the second parameter data crosses the upper voltage threshold value. At this stage, it is determined that the ostomy appliance is in a second operating state.

**[0269]** At time around 30h, curve 1304 shows that moisture is detected by the third electrode pair as the third parameter data crosses the upper voltage threshold value. In an example where the curves 1306, 1308, 1310 had not dropped below corresponding thresholds, curve 1304 indicates that moisture has reached the third electrode pair, and the present disclosure enables determining that the ostomy appliance is in a third operating state.

**[0270]** Fig. 23 shows an exemplary graphical representation of parameter data as a function of time and a whitening zone diameter (e.g. related to a radial thickness of a whitening ring surrounding the stomal opening) as a function of time. Fig. 23 illustrates the moisture propagation in the first adhesive layer as a function of time and illustrates a correlation between parameter data detected by the first electrode pair and the second electrode pair of the base plate and actual moisture on the proximal surface of the first adhesive layer of the base plate. The actual moisture propagation in the first adhesive layer may appear as a whitening zone (e.g. a white ring around the stomal opening) in the first adhesive layer. Moisture affects the first adhesive layer in that the moisture reacts with the composition of the first adhesive layer to form the white ring around the stomal opening, and thereby reduces adhesive performance of the base plate. Fig. 23 is obtained by experiments where water is applied from the stomal opening of the base plate to follow, using the electrodes of the base plate, the radial propagation of moisture leading to radial erosion of the first adhesive layer of the base plate.

**[0271]** Curve 1502 shows, as a function of time, first parameter data indicative of voltage measured by the first electrode pair of the base plate. Curve 1504 shows, as a function of time, second parameter data indicative of voltage measured by the second electrode pair of the base plate. Curve 1506 shows a diameter of the white ring as a function of time. The first parameter data shows a decrease in e.g. voltage measured by the first electrode pair over

time. It is also seen that the voltage of the second electrode pair drops at a later time than when the first parameter data shows a decrease in e.g. voltage dropped. This correlates well with the diameter of the white ring which goes from around 25-26mm when the first electrode pair is triggered (e.g. first parameter data shows a decrease) to 38mm when the second electrode pair is triggered (second parameter data shows a decrease). This corresponds substantially to the location of the first electrode pair at twice the first radial distance R1, and of the second electrode pair at twice the second radial distance R2.

**[0272]** It is noted that various regions and countries have various routines and recommendations to support optimal use of an ostomy appliance. For example, in regions of Europe, it may be indicated to the user that an ostomy appliance with a base plate as disclosed herein is an optimal state (corresponding to a first operating state) when the radial thickness of the whitening ring is between 0-15 mm (for a user not in compliance with a preferred use), such as between 0-7mm (for a user in compliance with a preferred use), such as between 0-5mm (recommended by a nurse).

**[0273]** For example, in Europe, it may be indicated to the user that an ostomy appliance with a base plate as disclosed herein is in suboptimal state (corresponding to a second operating state) and thereby indicate a consideration to change the base plate when the radial thickness of the whitening ring is such as between 5-10mm (recommended by a nurse), between 7mm and 10mm (for a user in compliance with a preferred use), and/or between 15mm and 30mm (for a user not in compliance with a preferred use).

**[0274]** For example, in Europe, it may be indicated to the user that an ostomy appliance with a base plate as disclosed herein is in a poor state (corresponding to a third operating state) and indicate a request to change the base plate when the radial thickness of the whitening ring is more than 10mm (recommended by a nurse), such as more than 15mm (for a user in compliance with a preferred use), such as more than 30mm (for a user not in compliance with a preferred use).

**[0275]** For example, in other regions (e.g. America), it may be indicated to the user that an ostomy appliance with a base plate as disclosed herein is an optimal state (corresponding to a first operating state) when the radial thickness of the whitening ring is between 0-20 mm (for a user not in compliance with a preferred use), such as between 0-10mm (for a user in compliance with a preferred use), such as between 0-10mm (recommended by a nurse).

**[0276]** For example, in other regions (e.g. America), it may be indicated to the user that an ostomy appliance with a base plate as disclosed herein is in suboptimal state (corresponding to a second operating state) and thereby indicate a consideration to change the base plate when the radial thickness of the whitening ring is such as between 10mm and 20mm (recommended by a nurse), between 10mm and 20 (for a user in compliance with a preferred use), and/or between 20mm and 40mm (for a user not in compliance with a preferred use).

**[0277]** For example, in other regions (e.g. America), it may be indicated to the user that an

ostomy appliance with a base plate as disclosed herein is in a poor state (corresponding to a third operating state) and indicate a request to change the base plate when the radial thickness of the whitening ring is more than 20mm (recommended by a nurse), such as more than 20mm (for a user in compliance with a preferred use), such as more than 40mm (for a user not in compliance with a preferred use).

**[0278]** The disclosed methods, and accessory devices allow to accommodate the regional preferences of user in their use of the ostomy appliance so as to adjust thresholds for the operating states to the regional preference or use and thereby provide appropriate navigation to the one or more changing rooms based on the operating state.

**[0279]** Figs. 24A-24B shows exemplary graphical representations of peel force as a function of a peeling distance travelled by a peeling action exercising the peel force (e.g. perpendicularly to the proximal (or distal) surface of the first adhesive layer) on a first adhesive layer of a base plate disclosed herein. The peel force relates to a required force to peel the first adhesive layer off the skin surface. The peeling distance is with respect to one end of the first adhesive layer where the peel force starts to be exercised. The peeling distance relates to the size or length of the first adhesive layer and thereby may relate to a size or length of a portion the first adhesive layer affected by moisture and of a portion of the first adhesive layer not affected by moisture. The peel forces illustrated in Figs. 24A-24B are representative of adhesive performance of the first adhesive layer of the base plate to the skin surface.

**[0280]** Composition of the first adhesive layer of the base plate as disclosed herein in one or more embodiments is formulated to provide adhesion of the base plate to the skin surface of the user when the base plate is worn and to maintain a dry and healthy skin surface. Avoiding maceration of skin when occluding the skin with an adhesive is done by transporting sweat away from the skin and into the first adhesive layer by means of e.g. hydrocolloid types and adhesive (e.g. hydrocolloid adhesives) forming part of an absorbing element of the first adhesive layer.

**[0281]** For example, when the absorbing element is in contact with moisture, (e.g. water, sweat, urine or faeces), the absorbing element absorb the moisture. This reduces the adhesion of the first adhesive layer to the skin.

**[0282]** For example, the first adhesive layer goes from a dry adhesive state with acceptable adhesive performance (e.g. acceptable adhesion and cohesion) in to a wet adhesive state (e.g. reduced or non adhesion and low cohesion gel).

**[0283]** Curve 1602 of Figs. 24A and 24B shows a peel force applied to the first adhesive layer as a function of a peeling distance travelled by a peeling action exercising the peel force on the first adhesive layer in a dry adhesive state, (e.g. not affected by moisture). The peel force is expressed in Newtons while the peeling distance is expressed in mm. The length of the first adhesive layer in dry adhesive state is illustrated by X5, corresponding to length of the first adhesive layer 1608 in dry adhesive state.

**[0284]** Curve 1602 shows that the peel force applied to the first adhesive layer in a dry adhesive state is equal to  $Y1$  when the peeling distance is less than  $X1$ . At  $X1$ , the peeling force drops as the peeling distance increases towards  $X5$  and the end of the first adhesive layer.

**[0285]** Curve 1604 of Fig. 24A shows a peel force applied to the first adhesive layer as a function of a peeling distance travelled by a peeling action exercising the peel force on the first adhesive layer in a wet adhesive state, (e.g. affected by moisture to the point of reaching a completely wet adhesive state, where the first adhesive layer has become a gel).

**[0286]** Curve 1604 shows that when the peeling distance is less than  $X2$ , the peel force applied to the first adhesive layer in a wet adhesive state is equal to  $Y2$  which has much lower value than  $Y1$ . This shows that the adhesive performance of the first adhesive layer is reduced when the first adhesive layer is in a wet adhesive state. At  $X2$ , the peeling force drops as the peeling distance increases until the end of the first adhesive layer. It is noted that  $X2$  is larger than  $X1$ , because the first adhesive layer in a wet adhesive state extends in volume, and thus in length due to the gelling of the components of the first adhesive layer.

**[0287]** The peel experiment illustrated in Fig. 24A shows a loss of adhesive performance when the first adhesive is in a wet adhesive state.

**[0288]** Curve 1606 of Fig. 24B shows a peel force applied to the first adhesive layer as a function of a peeling distance travelled by a peeling action exercising the peel force on the first adhesive layer illustrated 1610 which comprises a first portion 1610A in a dry adhesive state and a second portion 1610B in a wet adhesive state, (e.g. affected by moisture to the point of reaching a completely wet adhesive state, where the first adhesive layer has become a gel).

**[0289]** Curve 1606 shows that when the peeling distance is less than  $X3$ , the peel force applied to the first adhesive layer in a wet adhesive state is equal to  $Y3$  which has lower value than  $Y1$ . This shows that the adhesive performance of the first adhesive layer is reduced when the first adhesive layer comprises a portion in a wet adhesive state. At  $X3$ , the peeling force drops as the peeling distance increases until the end of the first adhesive layer. It is noted that  $X3$  corresponds to the length of the portion 1610A in dry adhesive state.

**[0290]** The peel experiment illustrated in Fig. 24B shows a loss of adhesive performance when the first adhesive is partly in a wet adhesive state.

**[0291]** Accordingly, Figs.24A-24B demonstrate that the operating state determined based on monitor data is indicative of adhesive performance of the base plate.

**[0292]** Figs. 25A-25B show exemplary graphical representations of a whitening zone diameter (e.g. related to a radial thickness of a whitening ring surrounding the stomal opening) as a function of time. Figs. 25A-25B illustrates the moisture propagation in the first adhesive layer

as a function of time and illustrates a diametral velocity of the moisture propagation on the proximal surface of the first adhesive layer of the base plate. The actual moisture propagation in the first adhesive layer may appear as a whitening zone (e.g. a white ring around the stomal opening) in the first adhesive layer. Figs. 25A-25B show measurements of a diameter of the whitening zone as a function of time as moisture propagates. Moisture affects the first adhesive layer in that the moisture reacts with the composition of the first adhesive layer to form the white ring around the stomal opening, and thereby reduces adhesive performance of the base plate.

**[0293]** Fig. 25A is obtained by experiments where water is applied from the stomal opening of the base plate of a first type to measure a velocity of the radial propagation of moisture leading to radial erosion of the first adhesive layer of the base plate of the first type.

**[0294]** Fig. 25B is obtained by experiments where water is applied from the stomal opening of the base plate of a second type to measure a velocity the radial propagation of moisture leading to radial erosion of the first adhesive layer of the base plate of the second type. The second type is different from the first type, in that the composition of the first adhesive layer may be different than the first adhesive layer of the second type when compared to the first type.

**[0295]** Curve 2104 shows, as a function of time, a diameter of the white ring of a base plate of the first type measured from a cut for a stomal opening to the first electrode pair.

**[0296]** Curve 2102 shows a linear approximation of curve 2104, and thereby characterizes the velocity from the cut to the first electrode pair. The linear approximation may be formulated as a linear equation of the type  $Y = v01 \cdot X + A$ , where  $Y$  is the diameter of the white ring in millimetres (mm),  $X$  is time in hours,  $v01$  is a diametral velocity of propagation of moisture in the base plate of the first type from the cut to the first electrode pair, and  $A$  relates to the diameter of the cut. In the experiment illustrated in Fig. 25A,  $v01 = 0.6$  mm/h and  $A$  is 22 (i.e. the cut for the stomal opening has a diameter of 22mm). Other experiments have shown that  $v01$  may be in the range of 0.5 mm/h to 0.8 mm/h, with an average diametral velocity  $v01$  of 0.65 mm/h for moisture to propagate from the cut to the first electrode pair. To obtain radial velocity  $V01$  for moisture to propagate from the cut to the first electrode pair from the results of Fig. 25A, the diametral velocity  $v01$  is to be divided by two:  $V01 = 0.3$  mm/h for the illustrated experiment.

**[0297]** Curve 2106 shows, as a function of time, a diameter of the white ring of a base plate of the first type measured from the first electrode pair to the second electrode pair.

**[0298]** Curve 2108 shows a linear approximation of curve 2106, and thereby characterizes the velocity from the first electrode pair to the second electrode pair. The linear approximation may be formulated as a linear equation of the type  $Y = v12 \cdot X + B$ , where  $Y$  is the diameter of the white ring in millimetres (mm),  $X$  is time in hours,  $v12$  is a diametral velocity of propagation of moisture in the base plate of the first type from the first electrode pair to the second electrode

pair, and B relates to approximate location of the first electrode pair from the center of the stomal opening. In the experiment illustrated in Fig. 25A,  $v_{12} = 0.2$  mm/h and B is 27,3 mm (i.e. the first electrode pair is place around 27,3 mm). Other experiments have shown that  $v_{12}$  may be in the range of 0.15 mm/h to 0.22 mm/h, with an average diametral velocity of 0.18 mm/h for moisture to propagate from the first electrode pair to the second electrode pair. To obtain radial velocity  $V_{12}$  for moisture to propagate from the first electrode pair to the second electrode pair from the results of Fig. 25A, the diametral velocity  $v_{12}$  is to be divided by two:  $V_{12} = 0.1$  mm/h for the illustrated experiment.

**[0299]** Curve 2112 shows, as a function of time, a diameter of the white ring of a base plate of the second type measured from a cut for a stomal opening to the first electrode pair.

**[0300]** Curve 2110 shows a linear approximation of curve 2112, and thereby characterizes the velocity from the cut to the first electrode pair. The linear approximation may be formulated as a linear equation of the type  $Y = v_{01} \cdot X + A$ , where Y is the diameter of the white ring in millimetres (mm), X is time in hours,  $v_{01}$  is a diametral velocity of propagation of moisture in the base plate of the second type from the cut to the first electrode pair, and A relates to the diameter of the cut. In the experiment illustrated in Fig. 25B,  $v_{01} = 0.3$  mm/h and A is 21.9 (i.e. the cut for the stomal opening has a diameter of 21.9 mm). Other experiments have shown that  $v_{01}$  may be in the range of 0.2 mm/h to 0.32 mm/h, with an average diametral velocity  $v_{01}$  of 0.275 mm/h for moisture to propagate from the cut to the first electrode pair. To obtain radial velocity  $V_{01}$  for moisture to propagate from the cut to the first electrode pair from the results of Fig. 25B, the diametral velocity  $v_{01}$  is to be divided by two:  $V_{01} = 0.15$  mm/h for the illustrated experiment.

**[0301]** Curve 2114 shows, as a function of time, a diameter of the white ring of a base plate of the second type measured from the first electrode pair to the second electrode pair.

**[0302]** Curve 2116 shows a linear approximation of curve 2114, and thereby characterizes the velocity from the first electrode pair to the second electrode pair. The linear approximation may be formulated as a linear equation of the type  $Y = v_{12} \cdot X + B$ , where Y is the diameter of the white ring in millimetres (mm), X is time in hours,  $v_{12}$  is a diametral velocity of propagation of moisture in the base plate of the second type from the first electrode pair to the second electrode pair, and B relates to approximate location of the first electrode pair from the center of the stomal opening. In the experiment illustrated in Fig. 25B,  $v_{12} = 0.2$  mm/h and B is 25.9 mm (i.e. the first electrode pair is place around 25.9 mm). Other experiments have shown that  $v_{12}$  may be in the range of 0.15 mm/h to 0.22 mm/h, with an average diametral velocity of 0.1 mm/h for moisture to propagate from the first electrode pair to the second electrode pair. To obtain radial velocity  $V_{12}$  for moisture to propagate from the first electrode pair to the second electrode pair from the results of Fig. 25B, the diametral velocity  $v_{12}$  is to be divided by two:  $V_{12} = 0.1$  mm/h for the illustrated experiment.

**[0303]** The experiments illustrated in Figs. 25A-25B correspond substantially with the location of the first electrode pair at twice the first radial distance  $R_1$ , and of the second electrode pair

at twice the second radial distance R2.

**[0304]** The present disclosure exploits the derivable velocities to determine a future operating state based on current operating state and/or previous operating states. As such, the derivable velocity may be used to determine the one or more changing rooms based on the operating state (e.g. current and/or future operating state).

**[0305]** Fig. 26A show an exemplary graphical representation of first parameter data as a function of time. In this example, the parameter data in the y-axis is in millivolts and time is in the x-axis.

**[0306]** Fig. 26A is obtained by experiments where semi-solid matter with various degrees of dilution is applied from the stomal opening of the base plate to follow, using the first electrode pair of the base plate, the radial propagation of moisture leading to radial erosion of the first adhesive layer of the base plate. Dilution is performed with tap water and semi-solid matter.

**[0307]** The exemplary results of Fig. 26A illustrates and mimics how the moisture content of the output would affect the first parameter data and thereby the operating state. This is done by mixing a semi-solid matter with water to various dilution factors. The content of moisture in real life changes the viscosity of the output and is affected by one or more factors: nutrition (type of food eaten by user, water intake, etc.), medication (e.g. vitamins/supplements, prescriptions, etc.), and health data (e.g. medical conditions of the user, diseases, ostomist, ileostomist, etc.).

**[0308]** Curve 2202 shows, as a function of time, first parameter data indicative of voltage measured by the first electrode pair of the base plate when a mixture of 0% semi-solid matter and 100% tap water is applied from the stomal opening of the base plate.

**[0309]** Curve 2204 shows, as a function of time, first parameter data indicative of voltage measured by the first electrode pair of the base plate when a mixture of 30% semi-solid matter and 70% tap water is applied. Curve 2204A shows, as a function of time, first parameter data indicative of voltage measured by the first electrode pair of the base plate when a mixture of 30% semi-solid matter and 70% tap water is applied.

**[0310]** Curve 2206 shows, as a function of time, first parameter data indicative of voltage measured by the first electrode pair of the base plate when a mixture of 30% semi-solid matter and 70% tap water is applied.

**[0311]** Curve 2208 shows, as a function of time, first parameter data indicative of voltage measured by the first electrode pair of the base plate when a mixture of 50% semi-solid matter and 50% tap water is applied.

**[0312]** Curve 2210 shows, as a function of time, first parameter data indicative of voltage measured by the first electrode pair of the base plate when a mixture of 100% semi-solid

matter and 0% tap water is applied.

**[0313]** Curve 2212 shows, as a function of time, first parameter data indicative of voltage measured by the first electrode pair of the base plate when a mixture of 100% semi-solid matter and 0% tap water is applied.

**[0314]** It may be noted that the more diluted the output is the earlier the first electrode pair is triggered.

**[0315]** Fig. 26B shows exemplary graphical representations of first parameter data as a function of percentage of output in the mixture applied.

**[0316]** Curve 2214 shows a linear approximation relating the trigger times of the first electrode pair to the percentage of semi-solid matter, and thereby characterizes how the viscosity of the semi-solid matter affects the propagation of moisture in the first adhesive layer. The curve 2214 represents a linear equation with a coefficient of 10.6 with an approximation precision of 87% for the exemplary results. This support a determination of a future operating state based one or more of: nutrition (type of food eaten by user, water intake, etc.), medication (e.g. vitamins/supplements, prescriptions, etc.), and health data (e.g. medical conditions of the user, diseases, ostomist, ileostomist, etc.), all of which may be used to determine which changing room to which one is directed.

**[0317]** It may be envisaged that a thin output may be detected based the early triggering time of the first electrode pair and thereby the future operating state may be determined accordingly.

**[0318]** Due to activity (e.g. sports, bending, movement), experimental results have shown that the operating state may be affected negatively by a reducing factor ranging from 2 to 10 compared to when the user has no or little activity (e.g. a sedentary user), For example, a wear time may be reduced by a factor of 2 to 10 due to an extensive activity.

**[0319]** Fig. 27A shows an exemplary graphical representation 2302 of parameter data as a function of time for a first type of base plate at a first predetermined temperature. The first predetermined temperature in the example depicted in Fig. 27A is 32 degrees Celsius. Fig. 27B shows an exemplary graphical representation 2304 of parameter data as a function of time for the first type of base plate at a second predetermined temperature. The second predetermined temperature in the example depicted in Fig. 27B is 37 degrees Celsius. The temperatures were selected to closely approximate human skin temperature.

**[0320]** Figs. 27A and 27B were obtained by applying fluid at a stomal opening of a base plate, wherein the stomal opening had a diameter of 22mm. The residual humidity of the environment for both experiments was 50%. As the fluid was absorbed by the base plate over time and the fluid propagated radially from the stomal opening outward, parameter data (e.g. voltages (mV)) was measured between a first electrode pair, a second electrode pair, and/or a



third electrode pair respectively.

**[0321]** Specifically, in Fig. 27A, curve 2306 shows, as a function of time, a decrease in voltage for the first electrode pair at approximately 8.3 hours. Curve 2308 shows, as a function of time, a constant voltage for the second electrode pair. And, curve 2310 shows, as a function of time, a constant voltage for the third electrode pair.

**[0322]** By comparison, in Fig. 27B, curve 2312 shows a decrease in voltage for the first electrode pair at approximately 7.6 hours. Curve, 2314 shows, as a function of time, a constant voltage for the second electrode pair. And, curve 2316 shows, as a function of time, a constant voltage for the third electrode pair.

**[0323]** Stated another way, in this example, moisture propagated approximately 11% faster when the temperature was 37 degrees Celsius in comparison to when the temperature was 32 degrees Celsius. This comparison shows that as temperature increases, wear time of the base plate decreases due to faster moisture propagation and adhesion degradation.

**[0324]** Another experiment was conducted where the propagation speed of fluid, applied at the stomal opening of a second type of base plate, was measured. Similar to the experiment depicted in Figs. 27A, 27B, the stomal opening had a diameter of 22mm and the residual humidity of the environment was 50%. The second type of base plate is different than the first type of base plate, in that the composition of the first adhesive layer of the first type of base plate is different than the composition of the first adhesive layer of the second type of base plate.

**[0325]** In this experiment, the fluid propagated between center of the hole and first electrode pair at approximately 0.15mm/hour when the temperature was 32 degrees Celsius. In comparison, the fluid propagated at approximately 0.2mm/hour when the temperature was 37 degrees Celsius. As such, this experiment similarly found that for another type of base plate as temperature increases, wear time of the second type of base plate decreases due to faster moisture propagation and adhesion degradation.

**[0326]** In view of the above results, a scaling factor may be applied to the operating state (e.g. wear time) of a base plate such that the scaling factor affects negatively the operating state (e.g. decreases the wear time) of the base plate as temperature increases and/or the scaling factor affects positively the operating state (e.g. increases the wear time) of the base plate as temperature decreases.

**[0327]** In some embodiments, the scaling factor may be predetermined. In these embodiments, the predetermined scaling factor may be constant. Alternatively, the predetermined scaling factor may be iteratively adjusted based on when the first electrode pair, the second electrode pair, and/or the third electrode pair are triggered. In at least some of these embodiments, the predetermined scaling factor may be iteratively adjusted.

**[0328]** The use of the terms "first", "second", "third" and "fourth", "primary", "secondary", "tertiary" etc. does not imply any particular order, but are included to identify individual elements. Moreover, the use of the terms "first", "second", "third" and "fourth", "primary", "secondary", "tertiary" etc. does not denote any order or importance, but rather the terms "first", "second", "third" and "fourth", "primary", "secondary", "tertiary" etc. are used to distinguish one element from another. Note that the words "first", "second", "third" and "fourth", "primary", "secondary", "tertiary" etc. are used here and elsewhere for labelling purposes only and are not intended to denote any specific spatial or temporal ordering. Furthermore, the labelling of a first element does not imply the presence of a second element and vice versa.

**[0329]** Although particular features have been shown and described, it will be understood that they are not intended to limit the claimed invention, and it will be made obvious to those skilled in the art that various changes and modifications may be made without departing from the scope of the claimed invention. The specification and drawings are, accordingly to be regarded in an illustrative rather than restrictive sense. The claimed invention is intended to cover all alternatives, modifications and equivalents.

#### **LIST OF REFERENCES**

##### **[0330]**

1 ostomy system

2 ostomy appliance

4 base plate

6 monitor device

8 accessory device

10 server device

12 network

14 coupling member

16 coupling ring

18, 18A, 18B, 18C, 18D stomal opening

20 docking station

22 first connector

24 user interface

100 monitor device housing

101 processor

102 first interface

104 second interface

106 memory

108 ground terminal of monitor device

110 first terminal of monitor device

112 second terminal of monitor device

114 third terminal of monitor device

116 fourth terminal of monitor device

118 fifth terminal of monitor device

120 coupling part

121 power unit

122 antenna

124 wireless transceiver

126 loudspeaker

128 haptic feedback element

140 sensor unit

142 sensor data

144 first sensor

146 second sensor

200 first adhesive layer

200A distal side/surface of first adhesive layer

200B proximal side/surface of first adhesive layer

202 second adhesive layer

202A distal side/surface of second adhesive layer

202B proximal side/surface of second adhesive layer

204 electrode assembly

204A distal side/surface of electrode assembly

204B proximal side/surface of electrode assembly

206 release liner

206A distal side/surface of the release liner

206B proximal side/surface of the release liner

208 top layer

208A distal side/surface of the top layer

208B proximal side/surface of the top layer

209 coupling ring

210 coupling part of first connector

211 first connector

212 terminals of first connector

213 first intermediate element

213A distal side/surface of first intermediate element

213B proximal side/surface of first intermediate element

214 support layer of electrode assembly

214A distal side/surface of support layer

214B proximal side/surface of support layer

216 electrodes of electrode assembly

217 connection parts of electrodes

218 masking element

218A distal side/surface of masking element

218B proximal side/surface of masking element

220, 220A, 220B electrode configuration

222 ground electrode

222A ground connection part

222B ground sensing part

222C ground connector part

224 first electrode

224A first connection part

224B first sensing part

224C first conductor part

226 second electrode

226A second connection part

226B second sensing part

226C second conductor part

228 third electrode

228A third connection part

228B third sensing part

228C third conductor part

230 fourth electrode

230A fourth connection part

230B fourth sensing part

232 fifth electrode

232A fifth connection part

232B fifth sensing part

234 first electrode part of the ground electrode

236 second electrode part of the ground electrode

238 third electrode part of the ground electrode

240 fourth electrode part of the ground electrode

242 ground terminal opening

244 first terminal opening

246 second terminal opening

248 third terminal opening

250 fourth terminal opening

252 fifth terminal opening

254 primary sensor point openings of masking element

254A primary first sensor point opening

254B primary second sensor point opening

256 secondary sensor point openings of masking element

256A secondary first sensor point opening

256B secondary second sensor point opening

258 tertiary sensor point openings of masking element

258A tertiary first sensor point opening

258B tertiary second sensor point opening

260 primary sensor point openings of first adhesive layer

260A primary first sensor point opening

260B primary second sensor point opening

262 secondary sensor point openings of first adhesive layer

262A secondary first sensor point opening

262B secondary second sensor point opening

264 tertiary sensor point openings of first adhesive layer

264A tertiary first sensor point opening

264B tertiary second sensor point opening

282 ground terminal element

282A ground terminal

284 first terminal element

284A first terminal

286 second terminal element

286A second terminal

288 third terminal element

288A third terminal

290 fourth terminal element

290A fourth terminal

292 fifth terminal element

292A fifth terminal

300 processor

302 memory

304 positioning device

306 input device

308 display device

310 interface

312 bus

314 monitor data

316 operating state data

318 configuration criteria data

320 ranking data

322 location data

324 operating state determination unit

326 location determination unit

328 selections output unit

330 ostomy bag

332 stoma

334 leakage sensor

336 fill-level sensor

338 selection box

340 changing room name

342 mode of transportation

344 type of establishment

346 distance between accessory device and changing room

348 estimated time of arrival

350 calendar data

352 future locations

354 ranking

356 handicap accessible option

358 indications

360 direction information

400 method

402 determine an operating state of an ostomy appliance

404 determine an operating state of the base plate

406 determine a remaining wear time of the base plate

408 receive an input and the one or more changing rooms are based on the received input

410 determine respective locations of one or more changing rooms based on the operating state

412 provide directions to a changing room of the one or more changing rooms

1000 curve representing the upper voltage threshold value

1002 curve representing the medium voltage threshold value

1004 curve representing the lower voltage threshold value

1006 curve representing a gradient limit

1100 curve showing, as a function of time, first parameter data indicative of voltage measured by the first electrode pair of the base plate

1102 curve showing, as a function of time, second parameter data indicative of voltage



measured by the second electrode pair of the base plate

1104 curve showing, as a function of time, third parameter data indicative of voltage measured by the third electrode pair of the base plate

1108 curve showing, as a function of time, fourth primary parameter indicative of voltage measured by the fourth electrode pair of the base plate

1110 curve showing, as a function of time, a gradient of fourth primary parameter indicative of voltage gradient

1112 curve showing, as a function of time, a gradient of fourth secondary parameter indicative of voltage gradient measured

1114 curve showing, as a function of time, a gradient of fourth tertiary parameter indicative of voltage gradient measured

1116 curve showing, as a function of time, a fourth secondary parameter indicative of voltage measured

1118 curve showing, as a function of time, a fourth tertiary parameter indicative of voltage measured

1200 curve showing, as a function of time, third parameter data indicative of voltage measured by the third electrode pair of the base plate

1202 curve showing, as a function of time, first parameter data indicative of voltage measured by the first electrode pair of the base plate

1204 curve showing, as a function of time, second parameter data indicative of voltage measured by the second electrode pair of the base plate

1206 curve showing, as a function of time, a fourth primary parameter indicative of voltage measured by the fourth electrode pair of the base plate

1208 curve showing, as a function of time, a fourth secondary parameter indicative of voltage measured

1210 curve showing, as a function of time, a fourth tertiary parameter indicative of voltage measured

1212 curve showing, as a function of time, a gradient of fourth primary parameter indicative of voltage gradient measured by the fourth electrode pair of the base plate

1214 curve showing, as a function of time, a gradient of fourth secondary parameter data indicative of voltage gradient measured

1216 curve showing, as a function of time, a gradient of fourth tertiary parameter indicative of voltage gradient measured

1300 curve showing, as a function of time, first parameter data indicative of voltage measured by the first electrode pair of the base plate

1302 curve showing, as a function of time, second parameter data indicative of voltage measured by the second electrode pair of the base plate

1304 curve showing, as a function of time, third parameter data indicative of voltage measured by the third electrode pair of the base plate

1306 curve showing, as a function of time, a fourth primary parameter indicative of voltage measured by the fourth electrode pair of the base plate

1308 curve showing, as a function of time, a fourth secondary parameter indicative of voltage measured

1310 curve showing, as a function of time, a fourth tertiary parameter indicative of voltage measured

1312 curve showing, as a function of time, a gradient of fourth primary parameter indicative of voltage gradient measured by the fourth electrode pair of the base plate

1314 curve showing, as a function of time, a gradient of fourth secondary parameter indicative of voltage gradient measured

1316 curve showing, as a function of time, a gradient of fourth tertiary parameter indicative of voltage gradient measured

1502 curve showing, as a function of time, first parameter data indicative of voltage measured by the first electrode pair of the base plate

1504 curve showing, as a function of time, second parameter data indicative of voltage measured by the second electrode pair of the base plate

1506 curve showing a diameter of the white ring as a function of time

1602 curve showing peel force applied to the first adhesive layer in a dry adhesive state as a function of peeling distance

1604 a peel force applied to the first adhesive layer as a function of a peeling distance travelled by a peeling action exercising the peel force on the first adhesive layer in a wet adhesive state

1606 a peel force applied to the first adhesive layer as a function of a peeling distance travelled by a peeling action exercising the peel force on the first adhesive layer partially wet

1608 length of the first adhesive layer 1608 in dry adhesive state

1610 the first adhesive layer which comprises a first portion in a dry adhesive state and a second portion in a wet adhesive state

1610A a first portion in a dry adhesive state

1610B a second portion in a wet adhesive state

2104 curve showing a function of time, a diameter of the white ring of a base plate of the first type measured from a cut for a stomal opening to the first electrode pair

2102 a linear approximation of curve 2104

2106 curve showing, as function of time, a diameter of the white ring of a base plate of the first type measured from the first electrode pair to the second electrode pair

2108 a linear approximation of curve 2106

2110 a linear approximation of curve 2112

2112 curve showing, as function of time, a diameter of the white ring of a base plate of the second type measured from a cut for a stomal opening to the first electrode pair

2114 curve showing, as a function of time, a diameter of the white ring of a base plate of the second type measured from the first electrode pair to the second electrode pair

2116 a linear approximation of curve 2114

2202 curve showing, as a function of time, first parameter data

2204 curve showing, as a function of time, first parameter data

2204A curve showing, as a function of time, first parameter data indicative of voltage measured by the first electrode pair of the base plate when a mixture of 30% output and 70% tap water is applied

2206 curve showing, as a function of time, first parameter data indicative of voltage measured by the first electrode pair of the base plate when a mixture of 30% output and 70% tap water is applied

2208 curve showing, as a function of time, first parameter data indicative of voltage measured by the first electrode pair of the base plate when a mixture of 50% output and 50% tap water is applied

2210 curve showing, as a function of time, first parameter data indicative of voltage measured by the first electrode pair of the base plate when a mixture of 100% output and 0% tap water is applied

2212 curve showing, as a function of time, first parameter data indicative of voltage measured by the first electrode pair of the base plate when a mixture of 100% output and 0% tap water is applied

2214 curve showing a linear approximation relating the trigger times of the first electrode pair to the percentage of output

2302 a graphical representation of parameter data as a function of time at a first predetermined temperature

2304 a graphical representation of parameter data as a function of time at a second predetermined temperature

2306 curve showing, as a function of time, a decrease in voltage for the first electrode pair at a first predetermined temperature

2308 curve showing, as a function of time, a constant voltage for the second electrode pair at the first predetermined temperature

2310 curve showing, as a function of time, a constant voltage for the third electrode pair at the first predetermined temperature

2312 curve showing, as a function of time, a decrease in voltage for the first electrode pair at a second predetermined temperature

2314 curve showing, as a function of time, a constant voltage for the second electrode pair at the second predetermined temperature

2316 curve showing, as a function of time, a constant voltage for the third electrode pair at the second predetermined temperature

M number of terminals in the first interface of the monitor device

## **REFERENCES CITED IN THE DESCRIPTION**

### Cited references

This list of references cited by the applicant is for the reader's convenience only. It does not form part of the European patent document. Even though great care has been taken in compiling the references, errors or omissions cannot be excluded and the EPO disclaims all liability in this regard.

### **Patent documents cited in the description**

- [US2013324952A1 \[0003\]](#)

- US2017340474A1 [0004]
- US2017140103A1 [0005]
- US6171289B1 [0006]
- US2004100376A1 [0007]

## Patentkrav

1. Tilbehørsanordning (8) til et stomisystem (1), der omfatter en monitoranordning (6) og et stomiapparat (2), hvilket  
5 stomiapparat (2) omfatter en bundplade (4), idet tilbehørsanordningen (8) omfatter:  
en hukommelse (302)  
en processor (300), og  
et interface (310), der er koblet til processoren (300), og som  
10 er konfigureret til at kommunikere med monitoranordningen (6), hvor interfacet (310) omfatter en displayanordning (308) og er konfigureret til at opnå monitordata (314) fra den til stomiapparatet (2) koblede monitoranordning (6),  
hvor processoren (300) er konfigureret til:  
15 at bestemme en driftstilstand for stomiapparatet (2)  
at bestemme respektive placeringer af ét eller flere omklædningsrum på grundlag af driftstilstanden, og  
på displayanordningen at udlæse (308) retninger til et omklædningsrum blandt det ene eller de flere omklædningsrum.  
20
2. Tilbehørsanordning ifølge krav 1, hvor bestemmelsen af driftstilstanden for stomiapparatet (2) omfatter bestemmelse af en driftstilstand for bundpladen (4).
- 25 3. Tilbehørsanordning ifølge krav 2, hvor bestemmelsen af driftstilstanden for bundpladen omfatter bestemmelse af en resterende slidtid for bundpladen (4).
4. Tilbehørsanordning ifølge et hvilket som helst af kravene  
30 1-3, hvor interfacet (310) omfatter en inputanordning (306), der er konfigureret til at modtage input fra en bruger.
5. Tilbehørsanordning ifølge krav 4, hvor et omklædningsrum vælges på grundlag af et valg, der foretages af brugeren via  
35 inputanordningen (306), blandt det ene eller de flere omklædningsrum.
6. Tilbehørsanordning ifølge et hvilket som helst af kravene

4-5, hvor et omklædningsrum vælges på grundlag af et valg, der foretages af brugeren via inputanordningen (306), af en transportform (342).

5 7. Tilbehørsanordning ifølge et hvilket som helst af kravene 1-6, hvor interfacet (310) er konfigureret til at modtage ét eller flere konfigurationskriterier fra en bruger af tilbehørsanordningen, og hvor processoren ydermere er konfigureret til at bestemme, om den ene eller de flere  
10 omklædningsrum opfylder det ene eller de flere konfigurationskriterier, og er konfigureret til at afsende en indikation til displayanordningen (308) i overensstemmelse med bestemmelsen af, at det ene eller de flere omklædningsrum opfylder det ene eller de flere konfigurationskriterier.

15

8. Tilbehørsanordning ifølge et hvilket som helst af kravene 1-7, hvor processoren (300) ydermere er konfigureret til at opnå en klassificering (354) af det ene eller de flere omklædningsrum og til at bestemme, om det ene eller de flere omklædningsrum  
20 opfylder eller overgår en tærskelklassificering.

9. Tilbehørsanordning ifølge et hvilket som helst af kravene 1-8 afhængigt af krav 7, hvor det ene eller de flere konfigurationskriterier omfatter omklædningsrum, der er  
25 handicapvenlige.

10. Tilbehørsanordning ifølge et hvilket som helst af kravene 1-9, hvor processoren (300) er konfigureret til at bestemme en placering af tilbehørsanordningen (8) og det omklædningsrum, der  
30 er tættest på placeringen af tilbehørsanordningen, blandt det ene eller de flere omklædningsrum.

11. Tilbehørsanordning ifølge et hvilket som helst af kravene 1-10, hvor processoren (300) er konfigureret til at modtage en  
35 fremtidig placering (352) af en bruger og bestemme respektive placeringer af det ene eller de flere omklædningsrum på grundlag af den fremtidige placering (352).

12. Fremgangsmåde (400), der udføres i en tilbehørsanordning (8), til betjening af en tilbehørsanordning (8) til et stomisystem (1), der omfatter en monitoranordning (6) og et stomiapparat (2), hvilket stomiapparat (2) omfatter en bundplade (4), idet fremgangsmåden (400) omfatter:
- 5 bestemmelse (402) af en driftstilstand for stomiapparatet (2)  
bestemmelse (410) af respektive placeringer af ét eller flere omklædningsrum på grundlag af driftstilstanden, og  
tilvejebringelse (412) af retninger til et omklædningsrum blandt  
10 det ene eller de flere omklædningsrum.
13. Fremgangsmåde ifølge krav 12, hvorved fremgangsmåden for at bestemme driftstilstanden for stomiapparatet omfatter bestemmelse (404) af en driftstilstand for bundpladen.
- 15
14. Fremgangsmåde ifølge krav 13, hvorved bestemmelsen af driftstilstanden for bundpladen omfatter bestemmelse (406) af en resterende slidtid for bundpladen.
- 20 15. Fremgangsmåde ifølge et hvilket som helst af kravene 12-14, der ydermere omfatter modtagelse (408) af et input fra en bruger via en inputanordning, og hvorved det ene eller de flere omklædningsrum vælges på grundlag af det modtagne input.



# DRAWINGS

Drawing

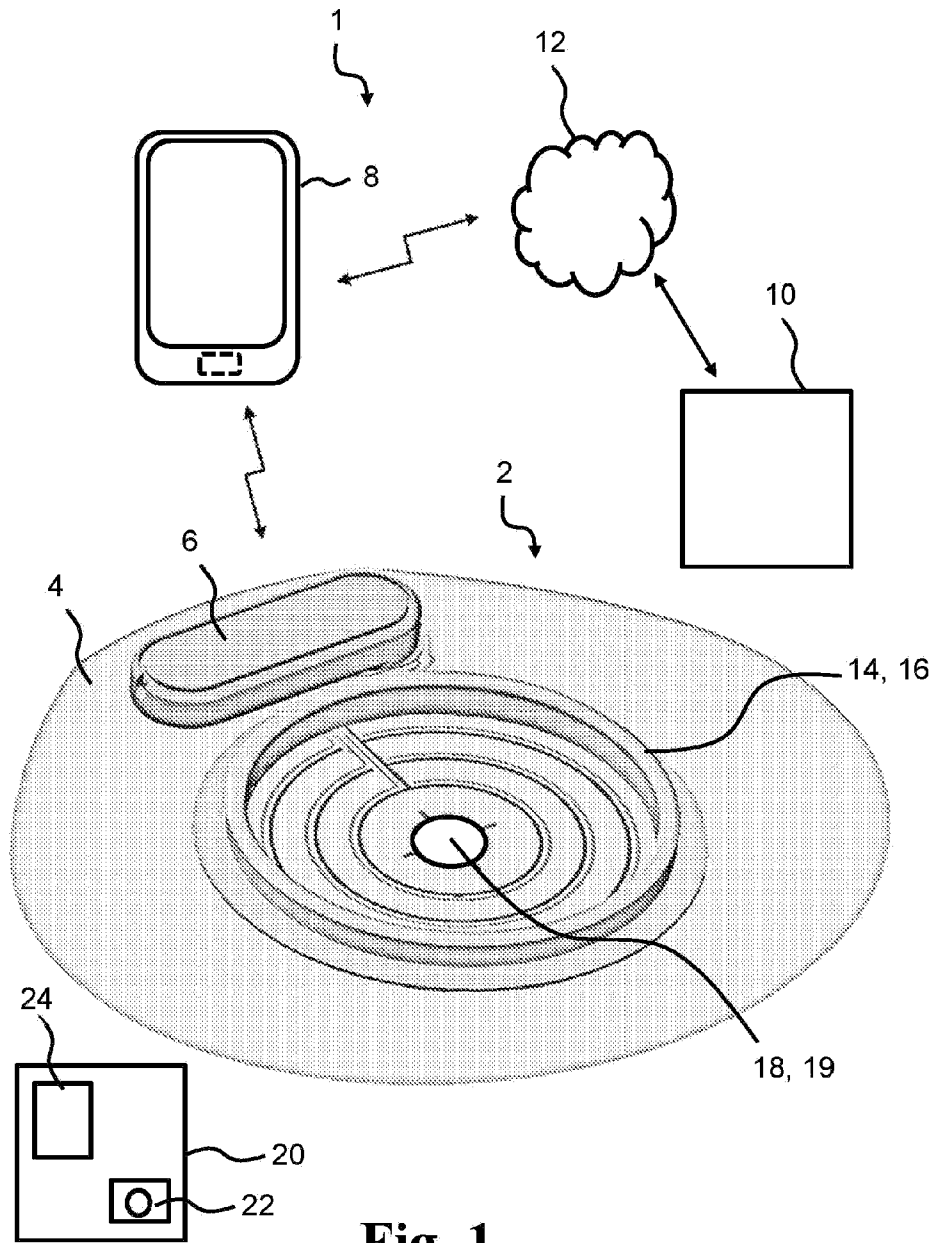

**Fig. 1**

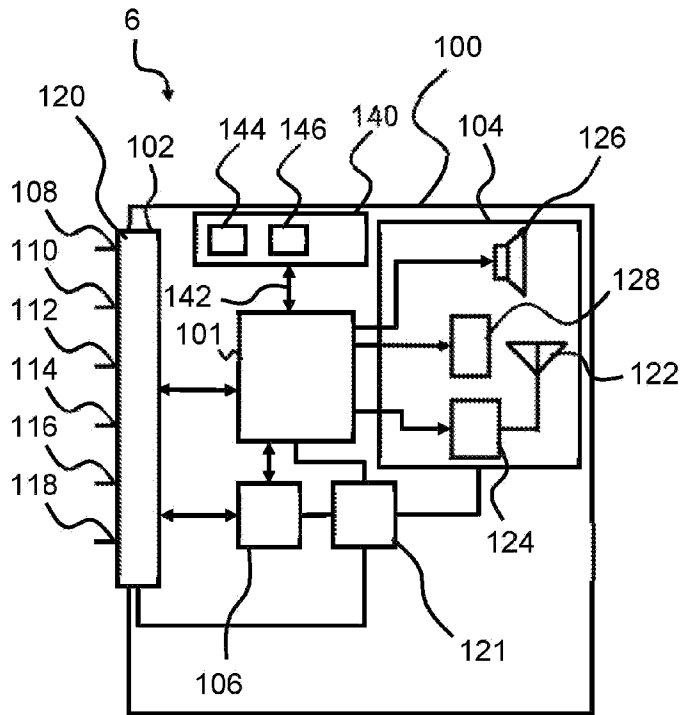

**Fig. 2**

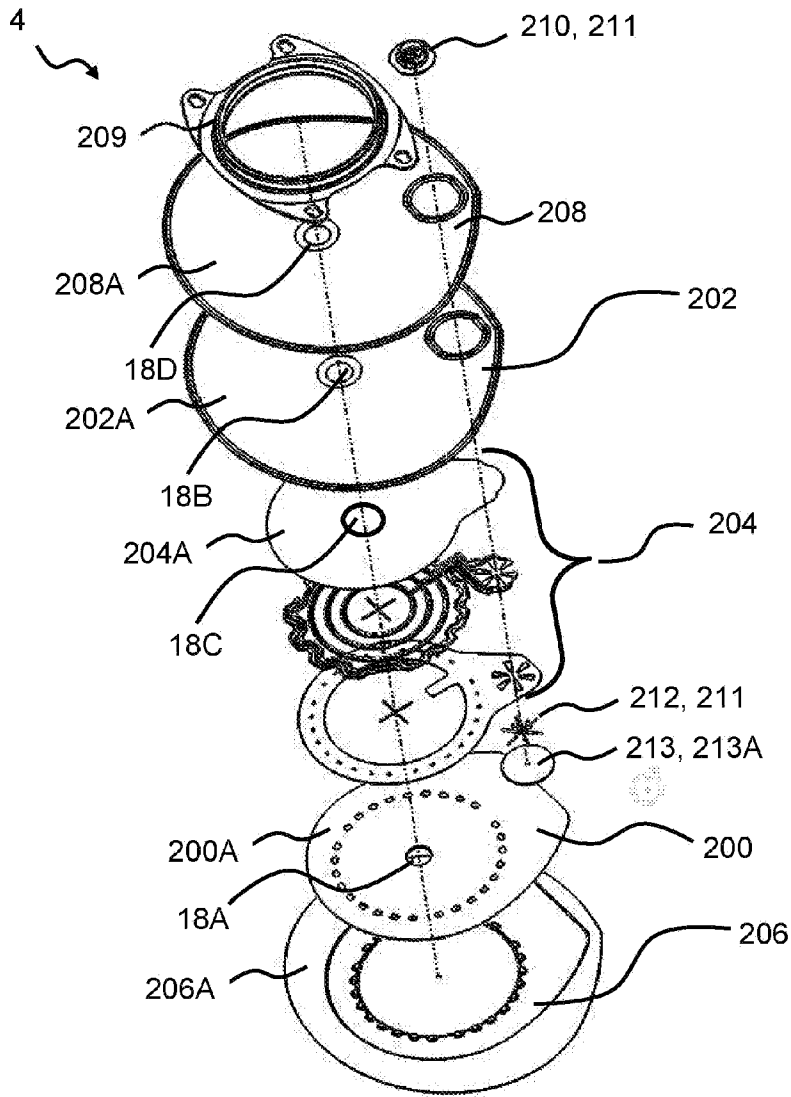

**Fig. 3**

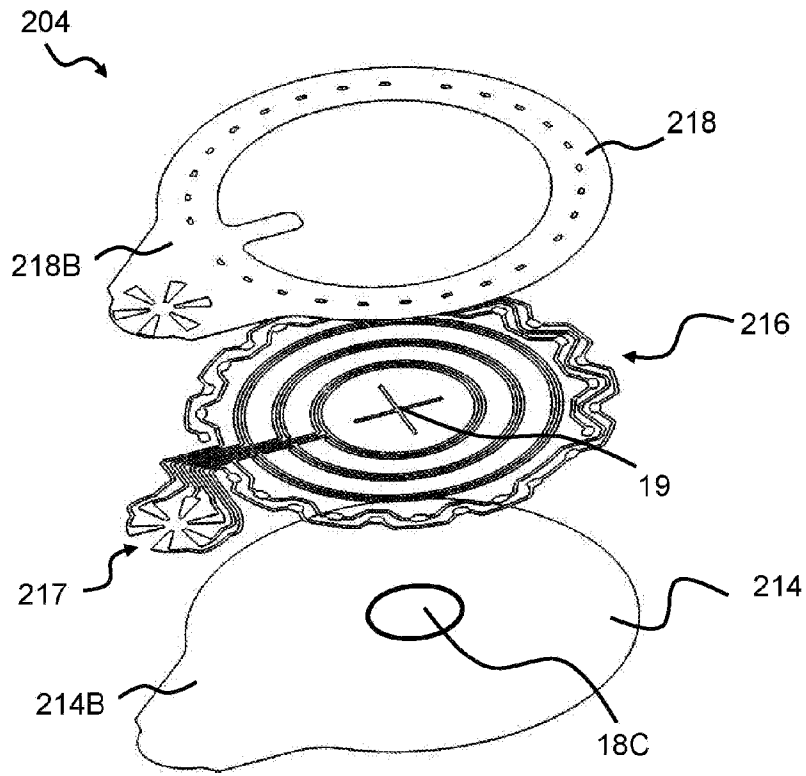

**Fig. 4**

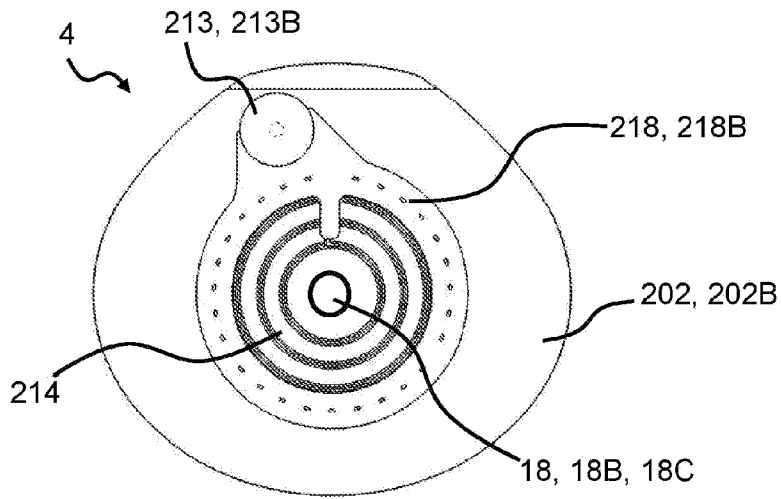

**Fig. 5**

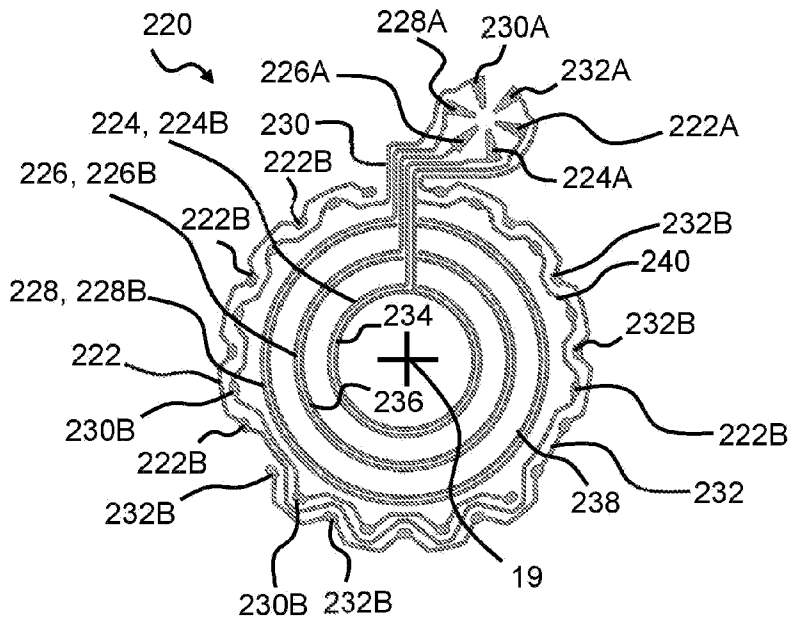

**Fig. 6**

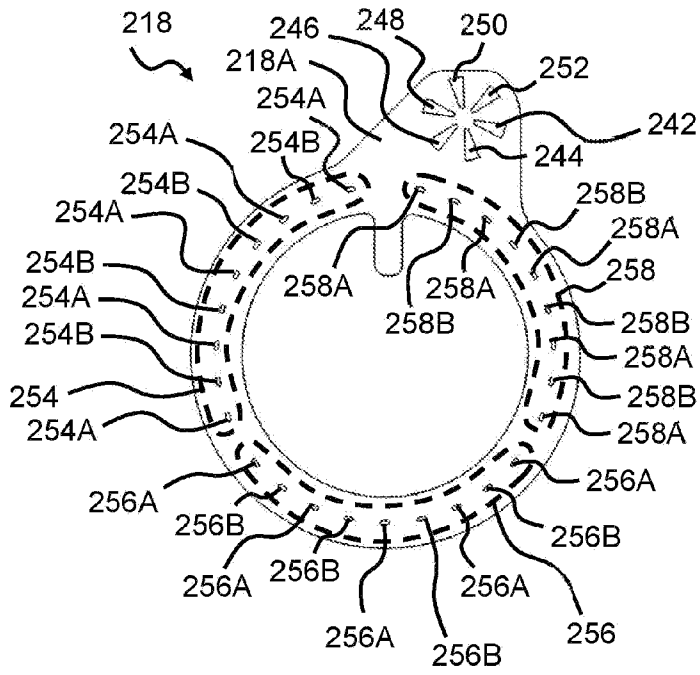

**Fig. 7**

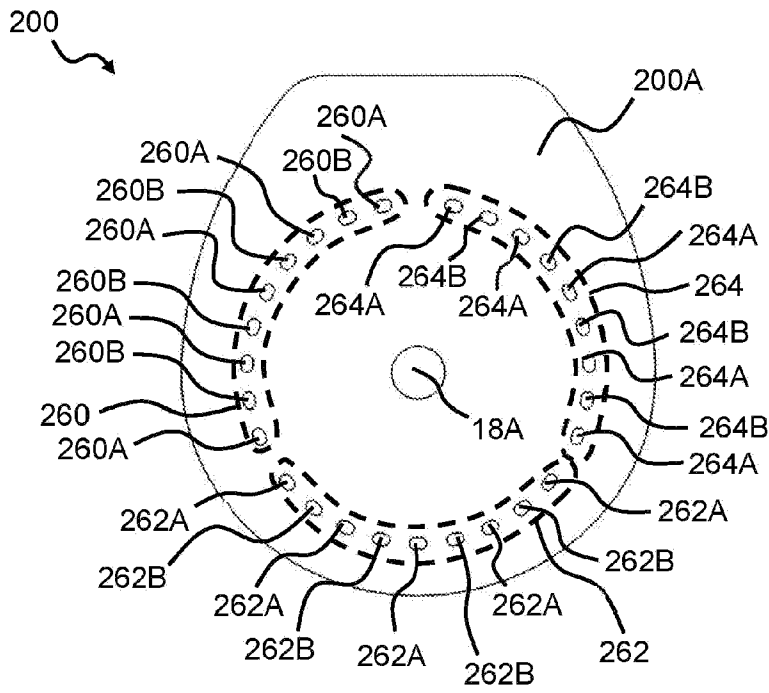

**Fig. 8**

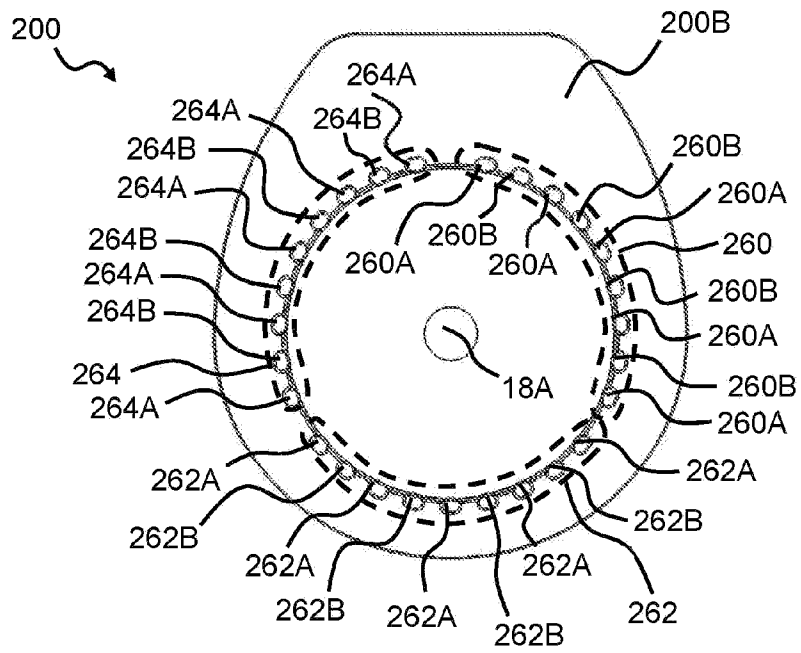
**Fig. 9**



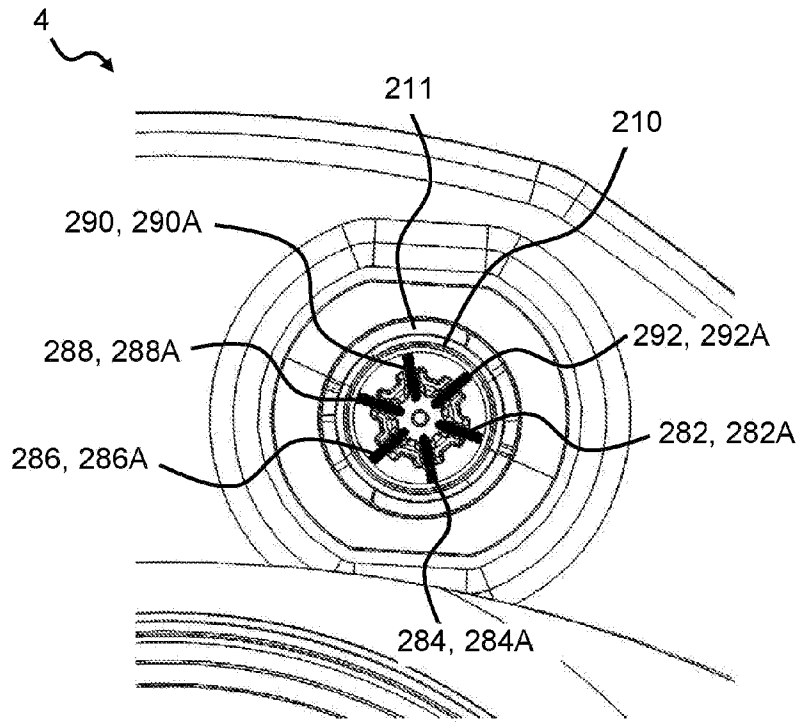

**Fig. 10**

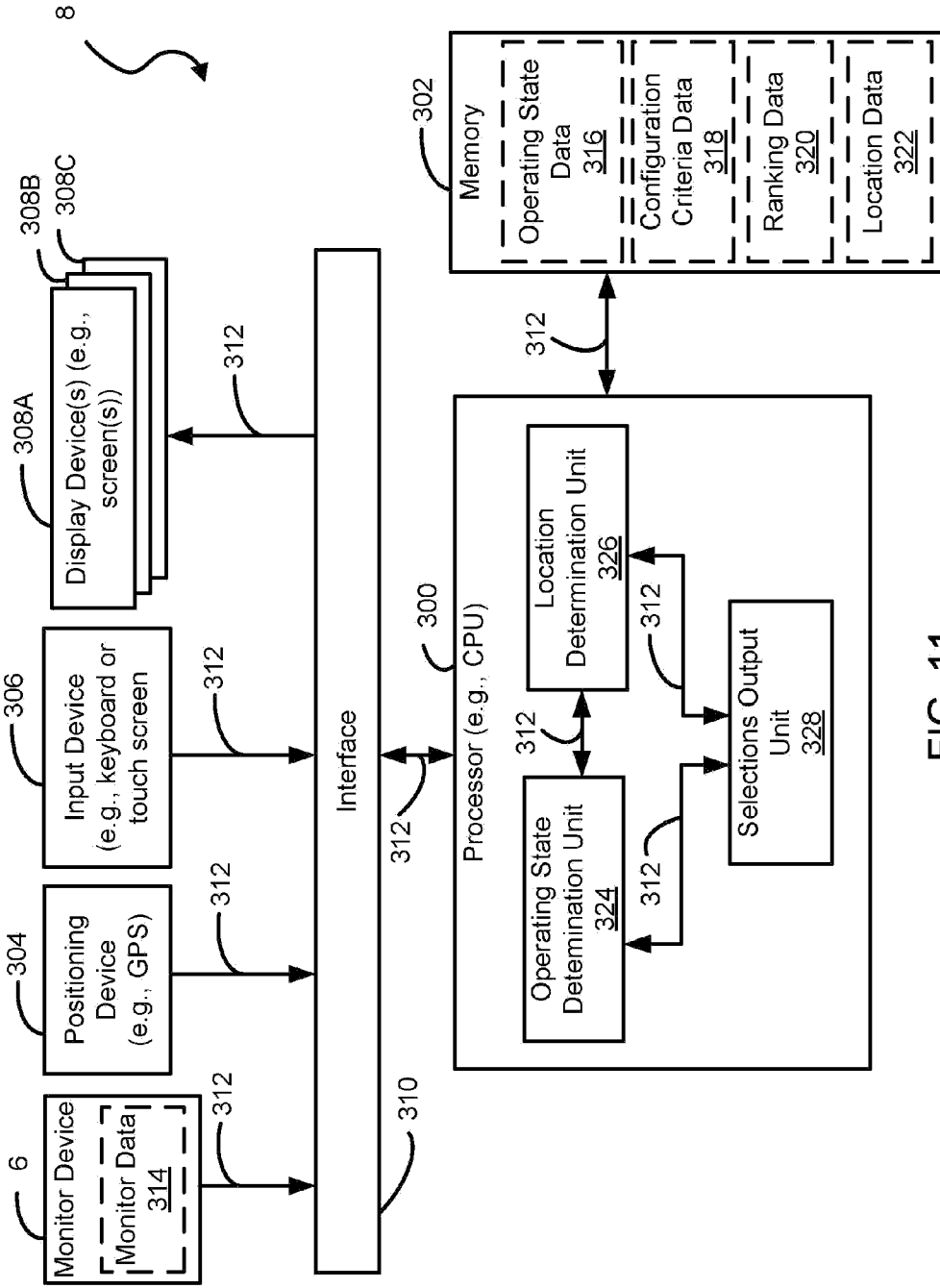

FIG. 11

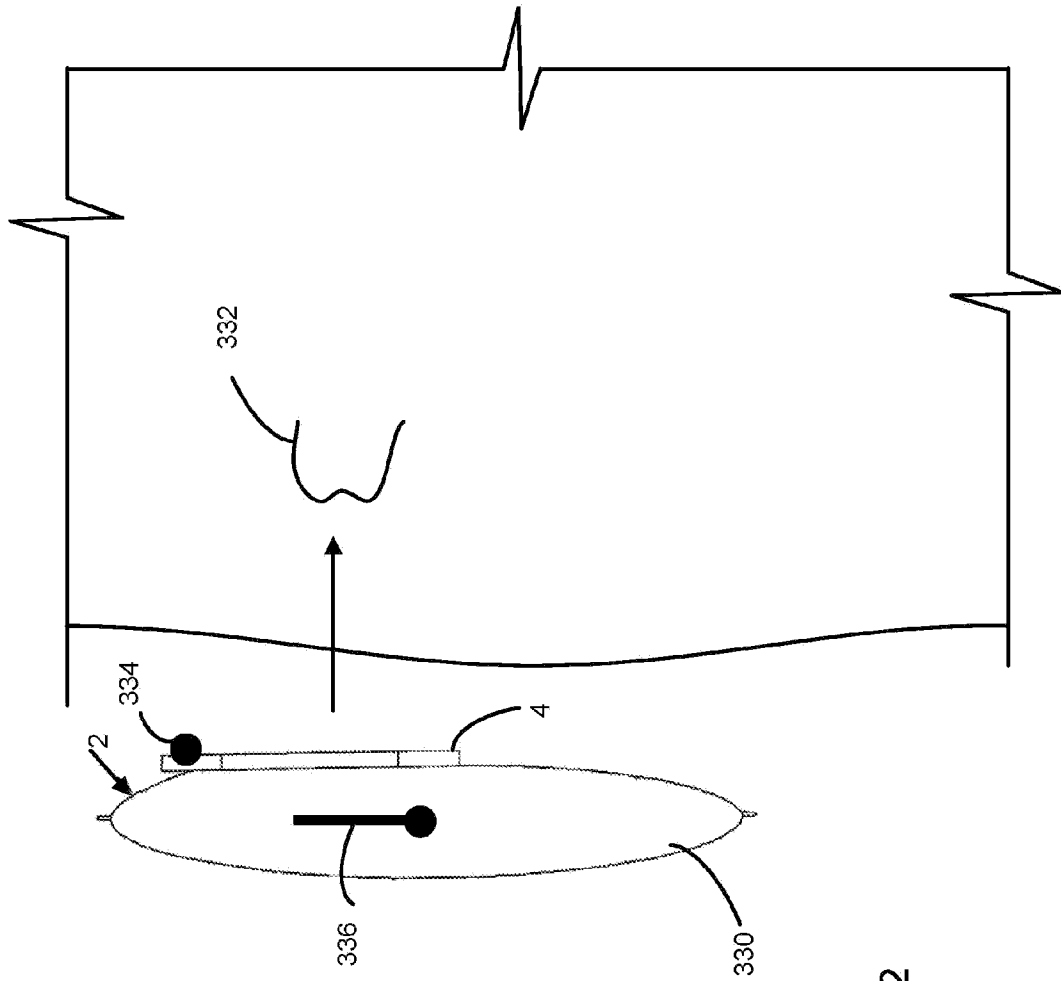

FIG. 12

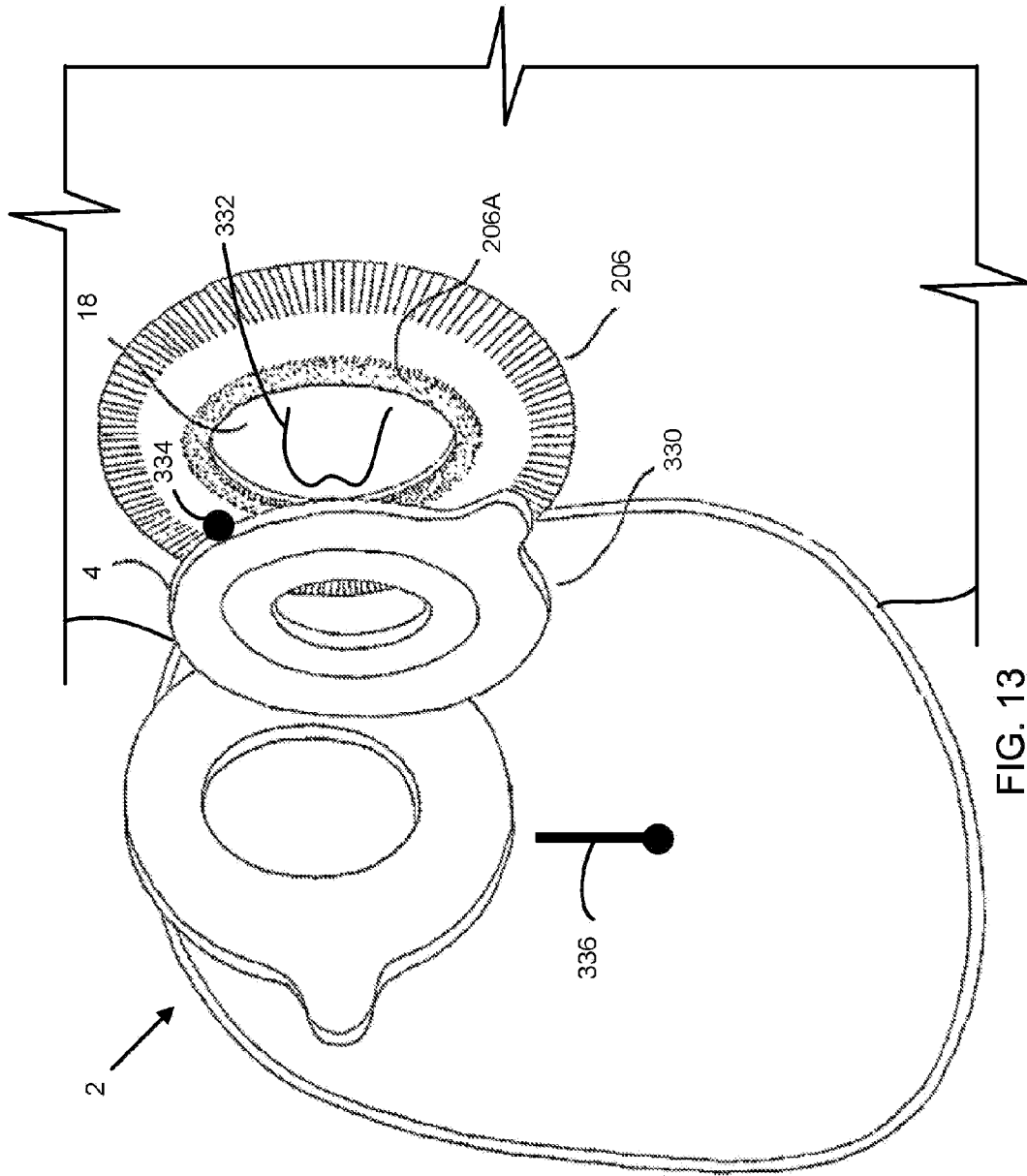

FIG. 13

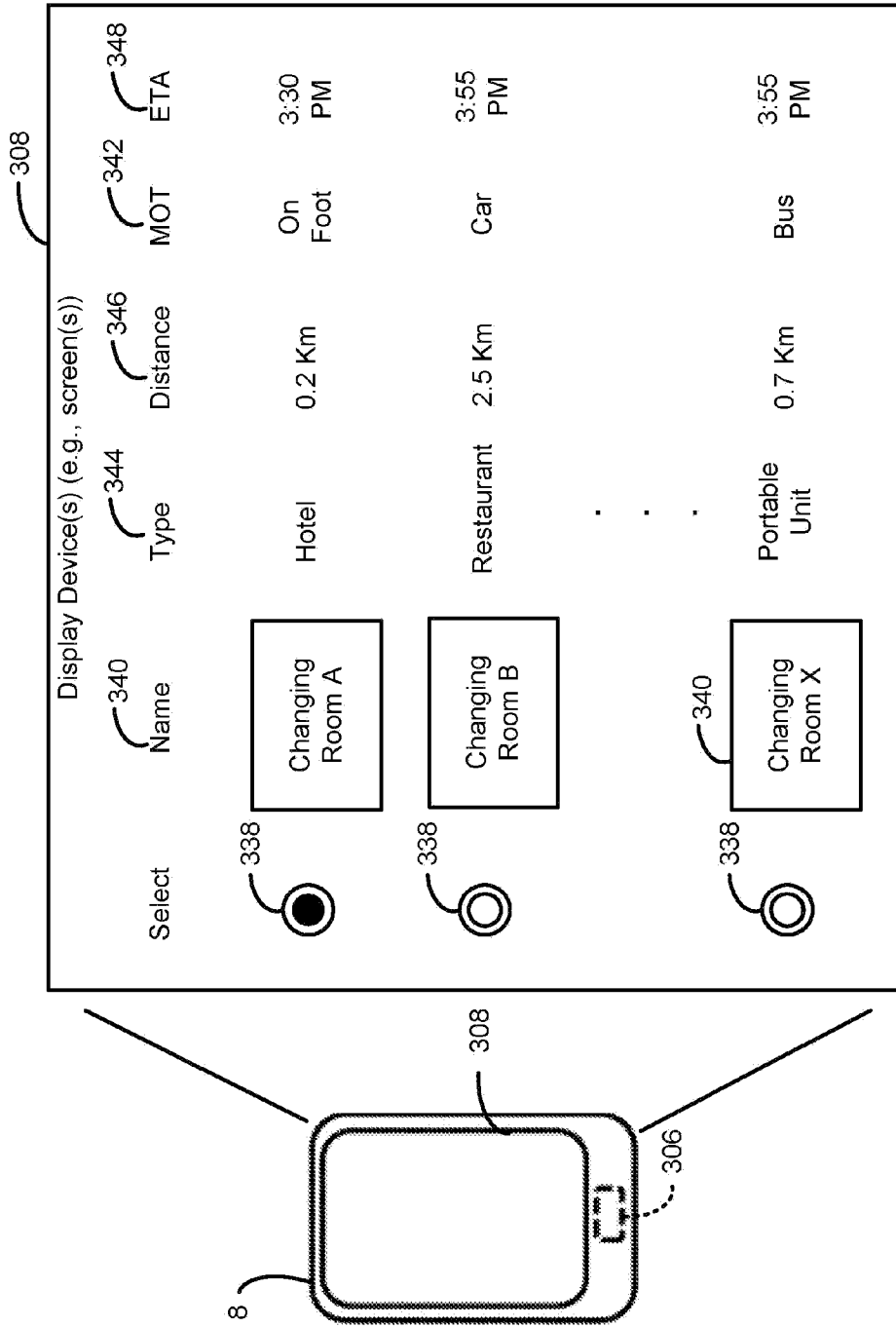

FIG. 14

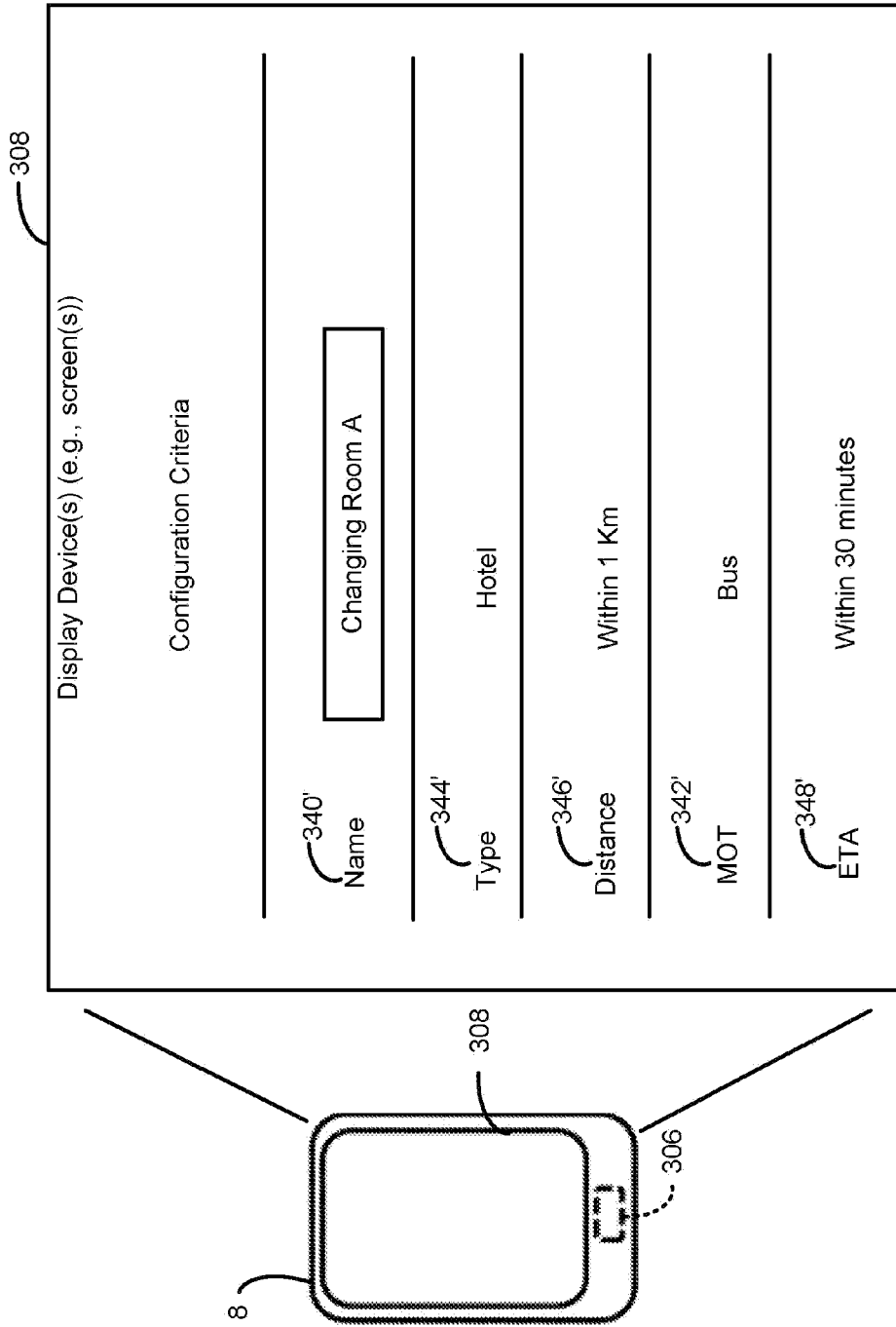

FIG. 15

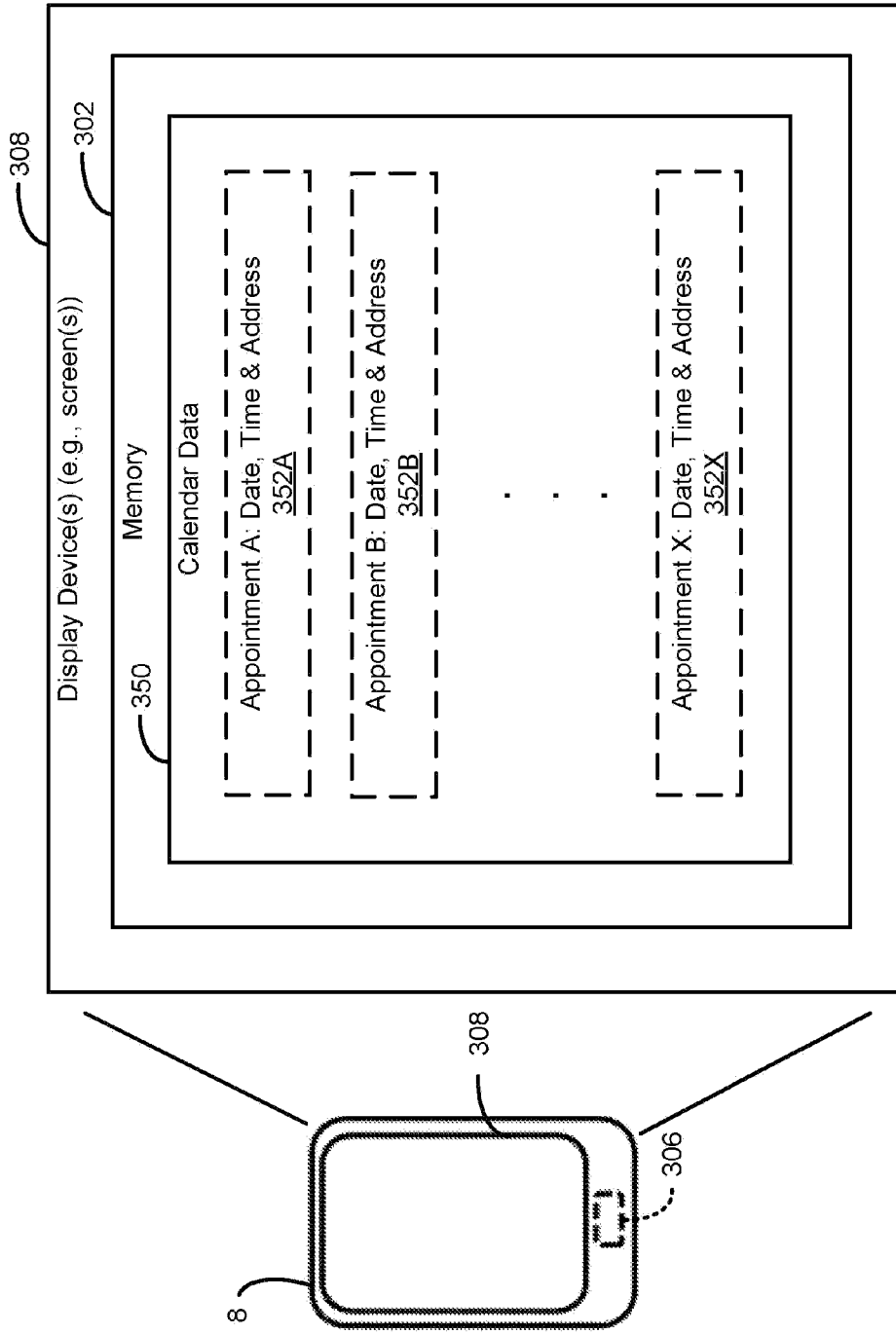

FIG. 16

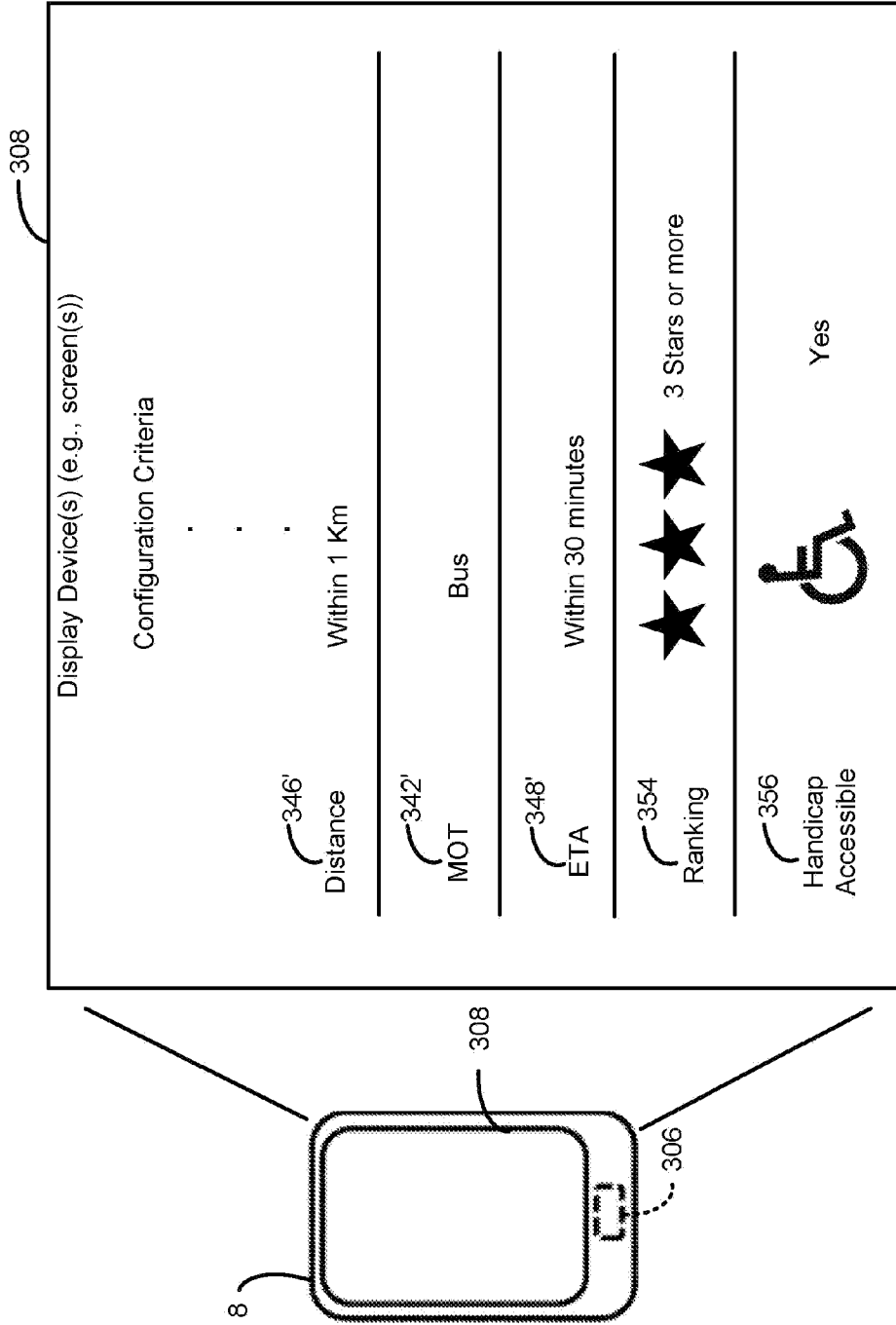

FIG. 17



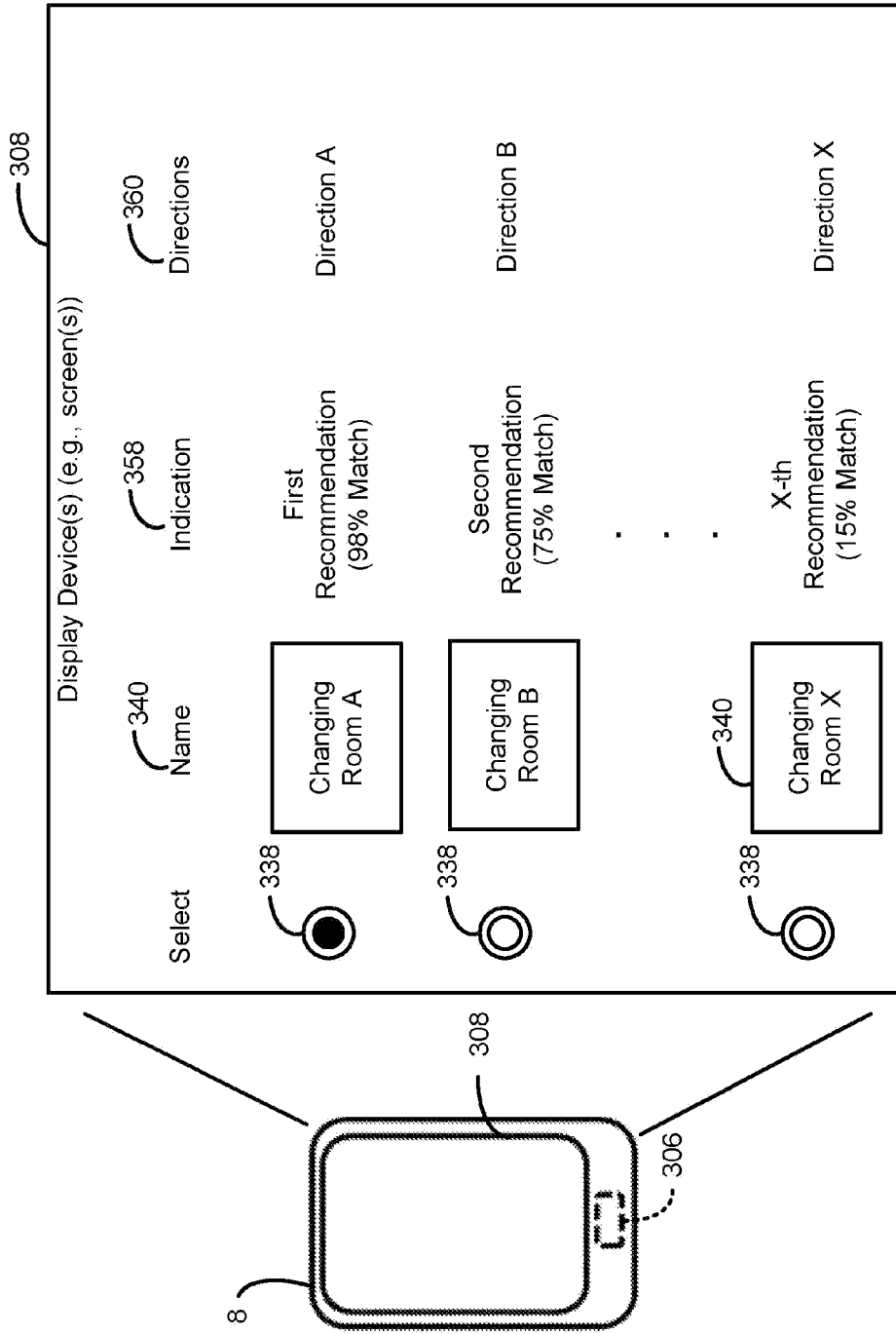

FIG. 18

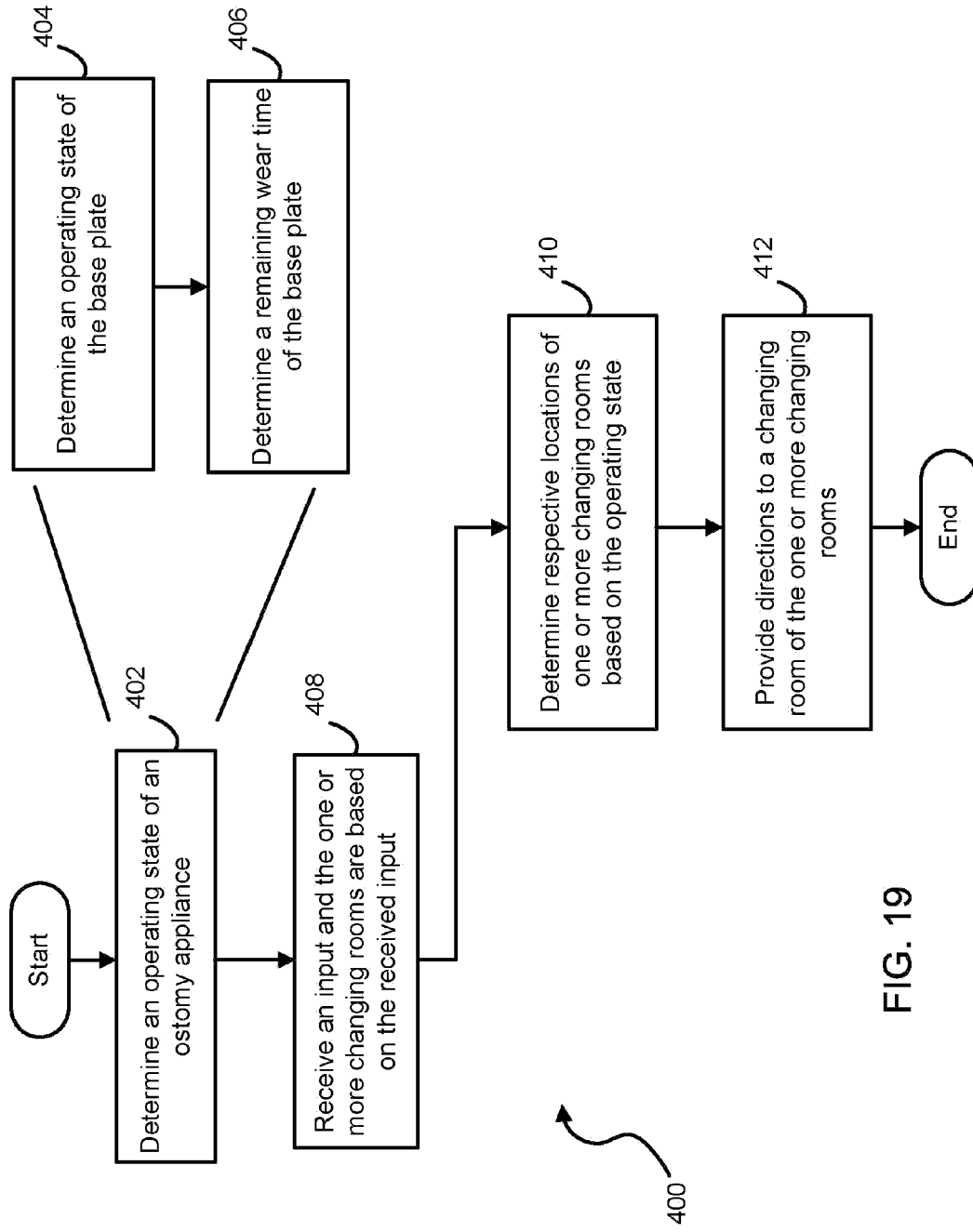
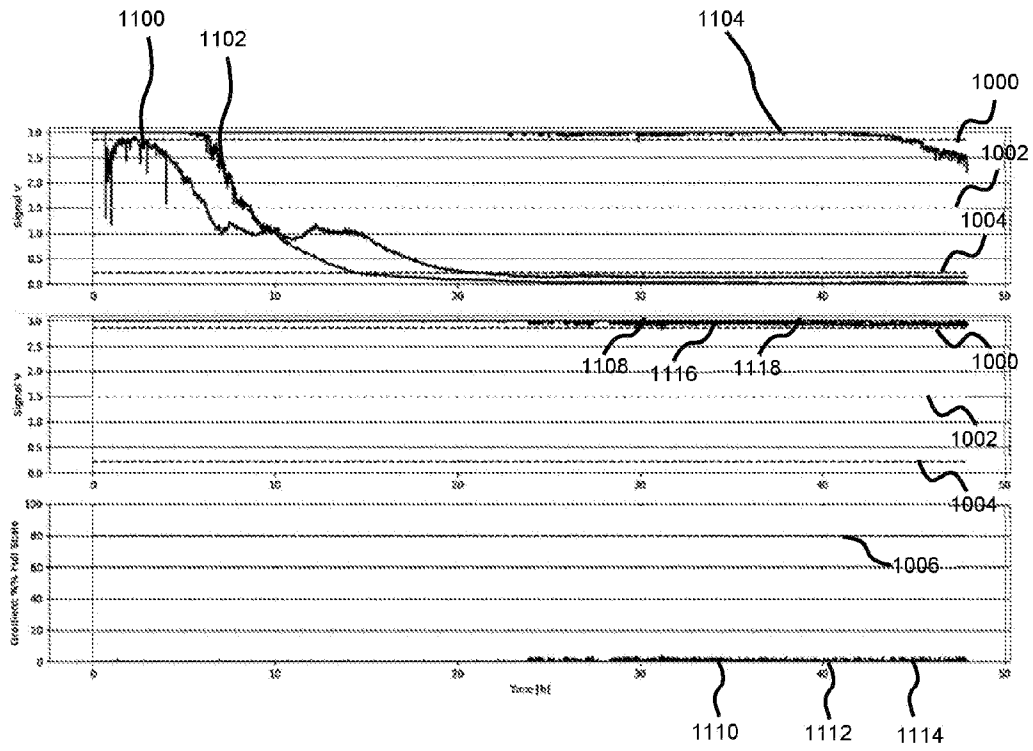

FIG. 19



**Fig. 20**

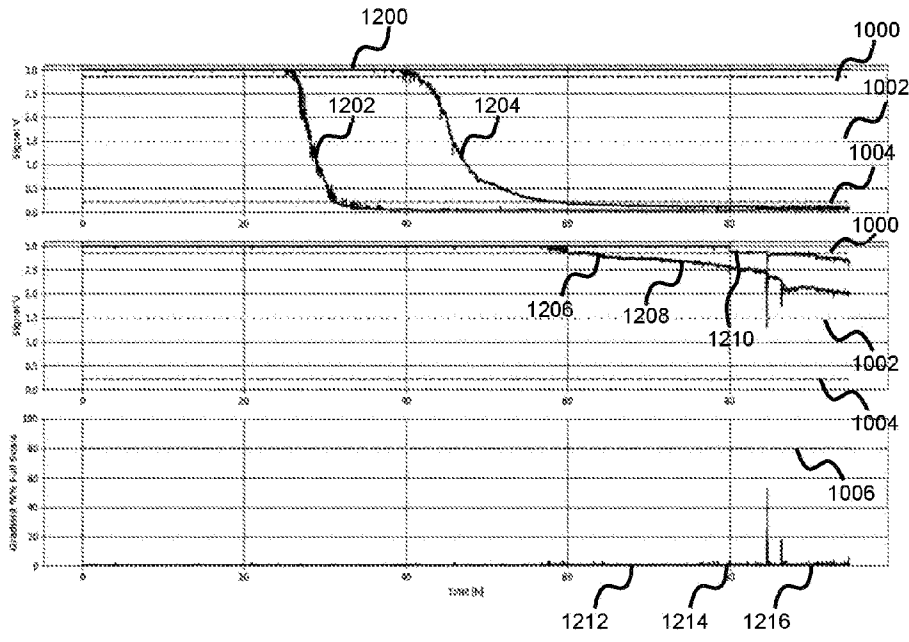
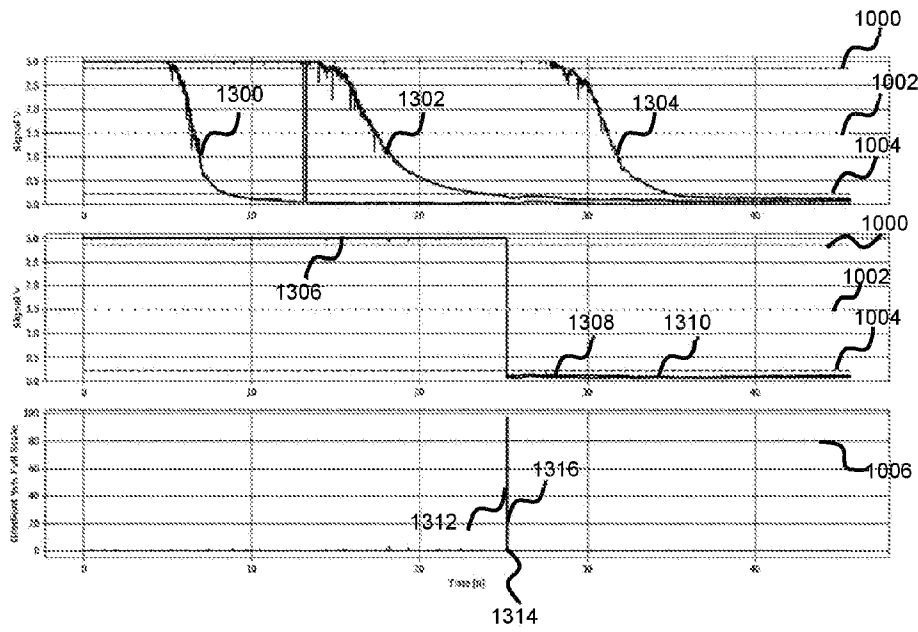
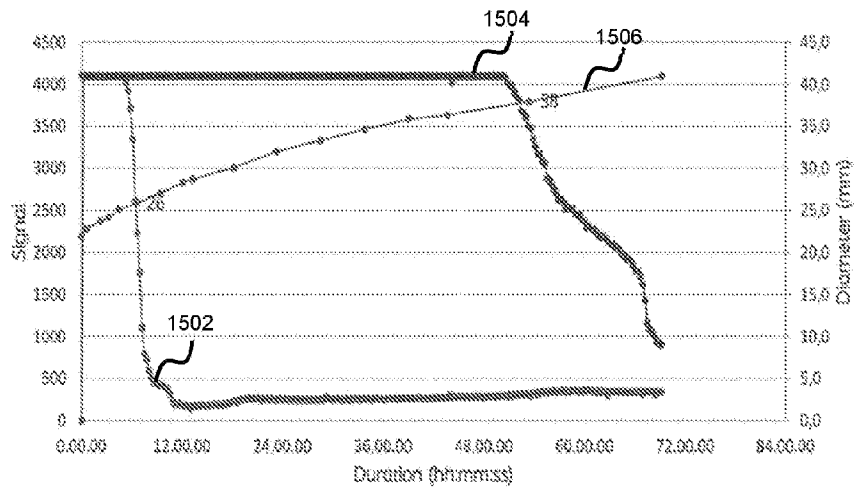

Fig. 21



**Fig. 22**



**Fig. 23**

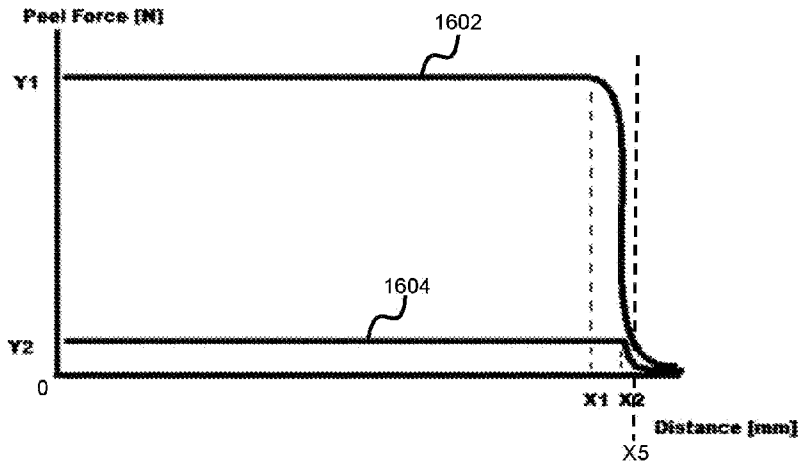

Fig. 24A

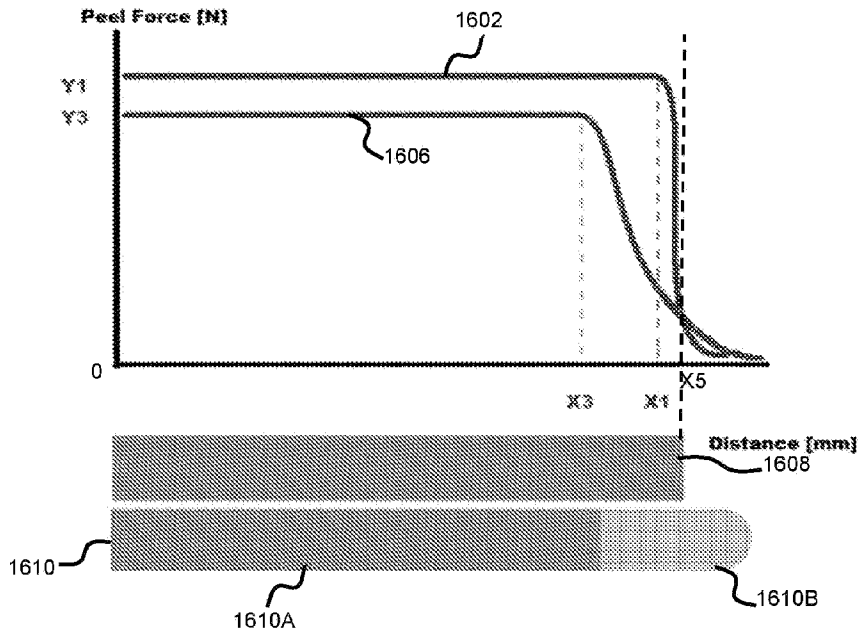
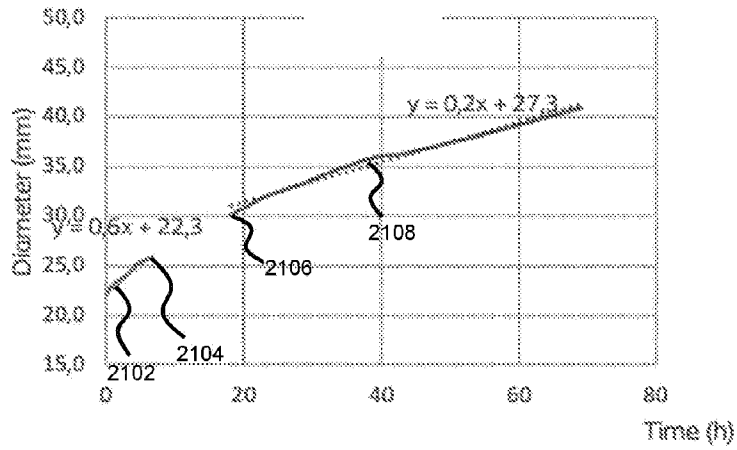
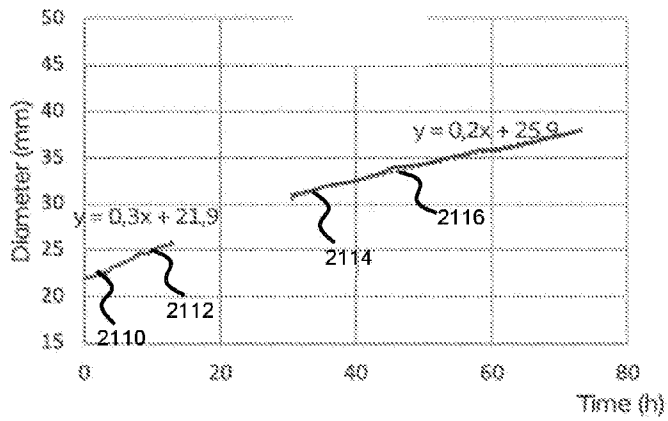
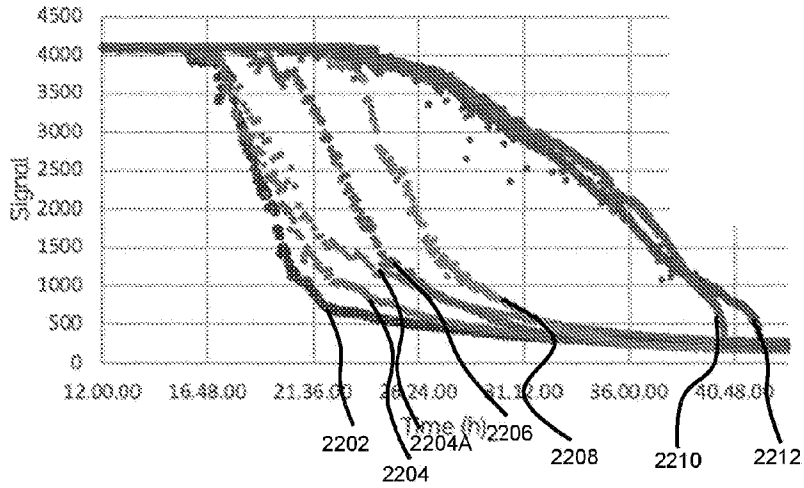

Fig. 24B

**Fig. 25A****Fig. 25B**





**Fig. 26A**

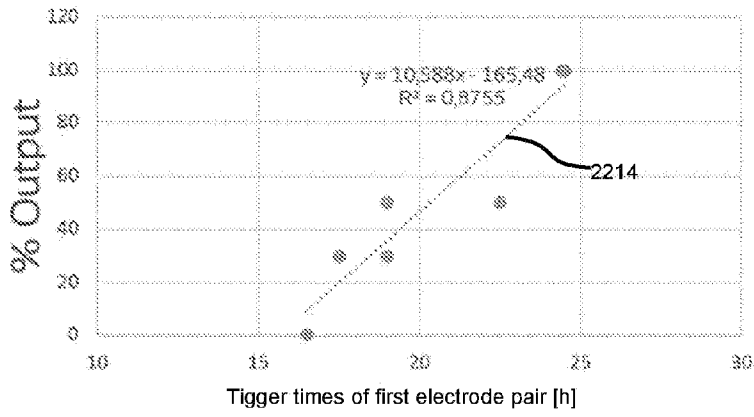

**Fig. 26B**

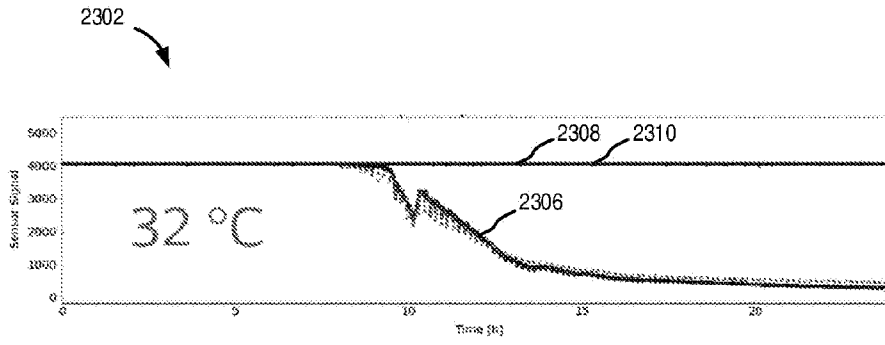

FIG. 27A

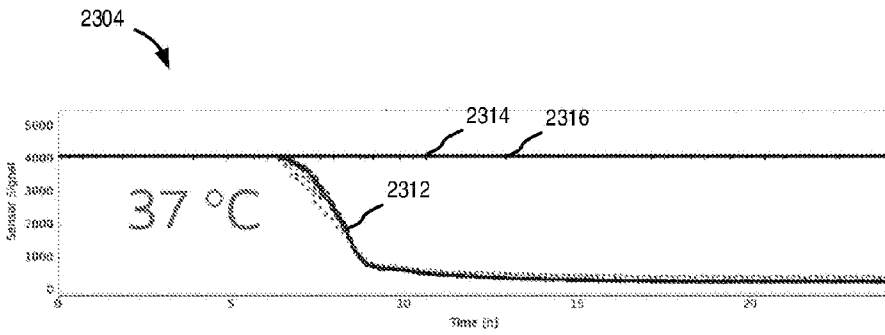

FIG. 27B