

(19) World Intellectual Property Organization
International Bureau



(43) International Publication Date
9 August 2001 (09.08.2001)

PCT

(10) International Publication Number
WO 01/56641 A1

- (51) International Patent Classification⁷: **A61M 25/00** (74) Agent: **LORUSSO, Mark, D.**; Kirkpatrick & Lockhart LLP, 75 State Street, Boston, MA 02109 (US).
- (21) International Application Number: PCT/US01/03621
- (22) International Filing Date: 2 February 2001 (02.02.2001) (81) Designated States (*national*): JP, US.
- (25) Filing Language: English (84) Designated States (*regional*): European patent (AT, BE, CH, CY, DE, DK, ES, FI, FR, GB, GR, IE, IT, LU, MC, NL, PT, SE, TR).
- (26) Publication Language: English
- (30) Priority Data: 60/180,263 4 February 2000 (04.02.2000) US
Published:
— with international search report
— before the expiration of the time limit for amending the claims and to be republished in the event of receipt of amendments
- (71) Applicant (*for all designated States except US*): **C. R. BARD, INC.** [US/US]; 730 Central Avenue, Murray Hill, NJ 07974 (US).
- (72) Inventor; and (75) Inventor/Applicant (*for US only*): **JACQUES, Steven, L.** [US/US]; 24 Grove Street, Westford, MA 01886 (US).
For two-letter codes and other abbreviations, refer to the "Guidance Notes on Codes and Abbreviations" appearing at the beginning of each regular issue of the PCT Gazette.

(54) Title: TRIPLE LUMEN STONE BALLOON CATHETER AND METHOD

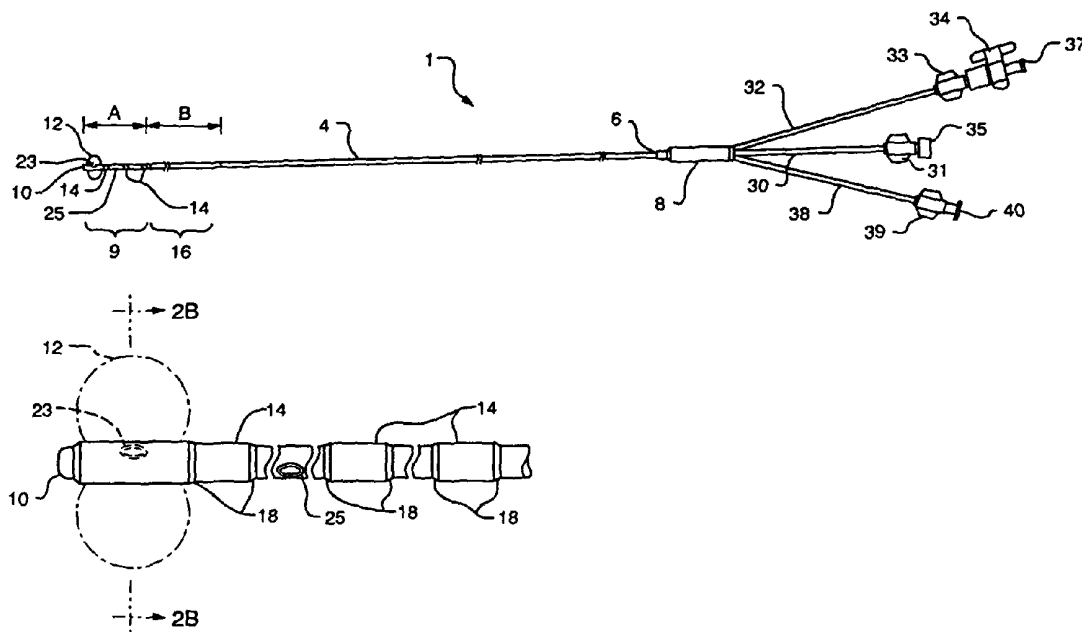

(57) Abstract: A triple lumen stone balloon catheter (1) having a tapered distal end (9). A lumen (24) dedicated to transmitting contrast media is dimensioned and adapted to conform to the shape of a kidney in a main shaft of the catheter and conform to the shape of a crescent in a distal end of the catheter. The geometric shaping of the contrast media lumen (24) enables wall thickness to be maintained within acceptable ranges to sustain desirable mechanical characteristics while allowing for enhanced contrast media flow. A method for employing the balloon catheter (1) is also disclosed.



WO 01/56641 A1

TRIPLE LUMEN STONE BALLOON CATHETER AND METHOD

Field of the Invention

This invention relates generally to balloon catheters having multiple lumens. Specifically, the invention relates to triple lumen stone balloon catheters and methods
5 for making same.

Background of the Invention

To provide an alternative to surgery, the medical industry devised non-invasive procedures and products that involve utilization of endoscopes. One such product is a stone balloon catheter. Stone balloon catheters generally comprise a sheath or
10 elongate tube having one or multiple lumens with an elastic balloon situated proximal to a distal end of the sheath. One lumen is adapted to communicate with the interior of the balloon so that a fluid or gas source attached to a proximal end of the catheter can be used to infuse either liquid or gas into the balloon to inflate it. Any other lumen provided in the catheter can be used for a variety of purposes such as providing a
15 channel for a guide wire to direct the insertion of the catheter into the patient.

Some of the most recent developments with stone balloon technology involves the use of a triple lumen catheter. Typically, such a catheter will have one lumen dedicated to infusion and aspiration of fluids or gases into or out of the balloon to effectuate inflation and deflation. A second lumen is dedicated to receive a guide wire
20 for placing the catheter. A third lumen is dedicated to infuse contrast media to allow for the fluoroscopic elucidation of the site being evaluated or manipulated.

Triple lumen catheters are used for two primary purposes: 1) diagnostic and 2) therapeutic. A triple lumen stone balloon is designed particularly for use as a therapeutic tool. As the name suggests, a stone balloon is used to remove crystalline
25 objects from a duct. One such duct is the common bile duct of the biliary system consisting of the liver, gall bladder and pancreas.

One of the enduring problems associated with catheter technology is the ability to quickly and effectively deliver contrast media to the desired locus. Due to the

-2-

combination of limited lumen size and the highly viscous nature of contrast media compositions, high levels of pressure (on the order of several atmospheres), are needed to effectuate delivery of the contrast media.

It is thus, an object of the invention to provide a triple lumen stone balloon that maximizes the ease and efficiency of contrast media delivery while maintaining infusion and aspiration rates for balloon inflation and deflation and lumen size to accommodate a guide wire. It is a further object of the invention to maintain desirable mechanical characteristics of triple lumen balloon catheters while maximizing contrast media flow. These and other objects of the invention will be apparent from a reading of the following summary and detailed description of the preferred embodiment.

Summary of the Invention

It has now been discovered that by balancing the relative cross-sectional areas and geometries of the lumen of a triple lumen stone balloon catheter, contrast media delivery can be maximized while maintaining acceptable inflation and deflation rates for expanding and deflating a stone balloon as well as providing adequate clearance for a guide wire. The selected geometries ensure that the following mechanical requirements are maintained. Compatibility of the guide wire lumen to receive in sliding engagement, a .035 inch guide wire was maintained by using a cross-sectional area of approximately about .041 inches nominal in the main shaft and about .037 inches minimum at the tip length. Balloon inflation and deflation times were maintained within acceptable ranges by reducing the cross-sectional area of the balloon inflation lumen in the main shaft and tip of the catheter.

To accommodate the high viscosity of contrast media that requires relatively high pressures to transmit the media through the main shaft of a catheter, the contrast media lumen cross-sectional area was increased and the shape of the contrast media lumen was adapted to conform to the shape of a kidney to maximize cross-sectional area while maintaining minimum wall thickness necessary to maintain the mechanical characteristics of stiffness, pushability, trackability, kinkability, tensile strength and elongation. To increase the cross-sectional area of the contrast lumen in the tip while again maintaining minimum wall thickness, the lumen was modified to conform to the

-3-

shape of a crescent. Transformation from the kidney shape to the crescent shape is accomplished by adjusting the individual air pressures in each of the three lumen during sheath formation via an extrusion process.

The mechanical requirements set forth above are defined as follows.

5 Pushability is the catheter's ability to transmit axial force to allow for transposition and placement in a particular channel or duct being negotiated. Trackability is the ability of a catheter to follow a coaxially placed guide wire. Stiffness is the relative stiffness value of the catheter relative to the stiffness of other prior art catheters. Kinkability is the ability of the main shaft and the distal tip of the catheter (approximately two inches
10 of the shaft and tip) to sustain a 180° deflection without collapse of the lumen. Tensile strength is an axial tensile strength of greater than four pounds. Elongation is the ability of the catheter to resist stretching less than five percent when a 3.5 lb. load is attached to an end of the catheter.

To achieve these goals, a catheter was formed from Pebax 7033 medical
15 grade having 20% Barium Sulfate. This material was chosen in part due to the fact that it meets the biological requirements of ISO 10993. The blend is easy to extrude, dimensionally stable, and provides a desired balance of mechanical characteristics such as stiffness and flexibility. The barium sulfate component provides fluoroscopic visualization capability and added stiffness to the catheter.

20 The main shaft of the catheter has a 7 French outside diameter that tapers down to a 5 French distal tip. The distal tip has a straight cylindrical outer shape to accommodate a balloon and marker bands as well as facilitate insertion into duct systems such as the biliary duct system. The 7 French diameter allows for the catheter to be used in a standard endoscope or duodenoscope having a 2.8 mm
25 minimum working channel. The interluminal and exterior walls of the catheter have thickness of about .006 inches minimum for the main shaft and about .004 inches minimum for the distal tip.

Brief Description of the Drawings

FIG. 1 is a plan view of a triple lumen balloon catheter according to one
30 embodiment of the invention.

-4-

FIG. 2 is a fragmented elevational view of a distal end of a triple lumen stone balloon catheter according to one embodiment of the invention.

FIG 2A is a view and cross section of a distal end of a triple lumen stone balloon catheter according to one embodiment of the invention.

5 FIG. 3 is a plan view of a tube junction assembly according to one embodiment of the invention.

FIG. 4 is a sectional view of a tube junction assembly according to one embodiment of the invention.

10 FIG. 5 is cross-sectional view of a tube junction assembly according to one embodiment of the invention.

FIG. 6 is a cross-sectional view of a catheter tube according to one embodiment of the invention.

FIG. 7 is a cross-sectional view of a catheter tube distal end with guide wire according to one embodiment of the invention.

15 FIG. 8 is a cross-sectional view of a catheter tube main shaft with guide wire according to one embodiment of the invention.

FIG. 9 is an elevational view of a catheter tube according to one embodiment of the invention.

20 FIG. 10 is a schematic of a catheter tube manufacturing apparatus and process according to one embodiment of the invention.

FIG. 11 is a cross-sectional view of a distal end of a catheter tube according to one embodiment of the invention.

FIG. 12 is a cross-sectional view of a main shaft end of a catheter tube according to one embodiment of the invention.

25 FIG. 13 is a sectional view of a triple lumen balloon catheter according to one embodiment of the invention.

FIG. 14 are cross-sectional views of a prior art balloon catheter designated "A".

FIG. 15 are cross-sectional views of a prior art balloon catheter designated "B".

30 FIG. 16 is a cross-sectional view of a catheter with a preferred maximum contrast medium lumen in the distal tip according to one embodiment of the invention.

-5-

FIG. 17 is a cross-sectional view of a catheter with a preferred minimum contrast medium lumen in the distal tip according to another embodiment of the invention.

5 FIG. 18 is a cross-sectional view of a catheter with a preferred minimum contrast medium lumen in the main shaft according to one embodiment of the invention

FIG. 19 is a cross-sectional view of a catheter with a preferred maximum contrast medium lumen in the main shaft according to another embodiment of the invention.

10 FIG. 20 is a perspective view of a triple lumen catheter according to one embodiment of the invention.

15 **Detailed Description of the Preferred Embodiment**

Referring to FIGS. 1, 2, 6-9 and 20, a triple lumen stone balloon catheter, shown generally as **1**, has an elongate sheath **4** with three lumens (not shown). Sheath **4** has a proximal end **6** attached to a tube junction assembly **8** that is preferably cylindrical in shape and adapted to receive tube extension legs, described below, at a distal end of junction assembly **8**. Sheath **4** has a distal end **9** that
20 comprises a distal tip **10** that is preferably radiused to ease insertion of catheter **1** into a duct, particularly the common bile duct of an individual. Distal end **9** preferably conforms to the shape of a straight cylinder and is adapted to receive a stone balloon **12** that is preferably a latex based balloon. Proximal and distal ends of balloon **12** are
25 preferably secured to distal end **9** with Loctite® adhesive.

Radio-opaque marker bands **14** (preferably less than 6 French), are provided about distal end **9** proximal to stone balloon **12** and are preferably spaced about 1cm apart. However, marker bands **14** can be spaced any known and accepted increment to enable use as a measuring device or feature. The placement and spacing of
30 marker bands **14** is set so that the marker bands can be used to measure the size of

-6-

strictures and stones as well as to determine balloon position within a duct. Marker bands **14** are secured to distal end **9** with adhesive (not shown) and epoxy **18**. An adhesive such as Loctite® is used to attach marker bands **14** to distal end **9**. Epoxy **18** such as Tra-Bond epoxy is used to provide a chamfered edge to marker bands **14** as shown in FIG. 1. Distal end **9** is preferably from about 0.4" to about 2" long to accommodate the stone balloon and marker bands (shown as "A" in FIG. 1).

Extending proximally from distal end **9** is taper portion **16**. Taper portion **16** is preferably from about 4" to about 20" and more preferably from about 8" to about 16" (shown as "B" in FIG. 1). A proximal end of taper **16** has an outside diameter of about 7 French while a distal end of taper **16** has an outside diameter of about 5 French. Taper portion **16** facilitates the ease by which the catheter assembly can slide through the working channel of a duodenoscope and into the Papilla of Vater to gain entry to the common bile duct of the biliary tree.

As stated, sheath **4** has three lumens. A first lumen **20** extends from proximal end **6** to distal end **10**. First lumen **20** preferably has a distal port that exists axially from distal tip **10**. A portion of sheath **4** that forms a proximal end of first lumen **20** is connected to a guide wire leg extension **30**. Guide wire leg extension **30** has a lumen **20a** (shown in FIG. 13) that communicates with first lumen **20**. Guide wire leg extension **30** has a guide wire extension leg assembly **31** that provides a finger grasp for operating leg extension **30**. A luer cap **35** has threading which engages threading on a proximal end of leg extension **30**. Guide wire extension leg **30** and first lumen **20** are preferably sized and adapted to receive a .035" guide wire. First lumen **20** and the lumen of guide wire extension leg **30** are preferably about .041". To provide visual reference, the phrase ".035 guide wire" can be printed on an exterior surface of guide wire extension leg **30**. Extension leg **30** can also be color-coded purple in accordance with an industry standard for a .035" guide wire product.

A second lumen **22** extends preferably from proximal end **6** to a point proximal to distal tip **10**. Second lumen **22** has a balloon distal port **23** situated within the axial length of stone balloon **12** so that second lumen **22** communicates with an interior surface of stone balloon **12**. A portion of sheath **4** that forms a proximal end of

-7-

second lumen **22** is connected to a balloon extension leg **32**. Balloon extension leg **32** has a lumen **22a** (shown in FIG. 13) that is in communication with second lumen **22**. Balloon extension leg **32** has a balloon extension leg assembly **33** that provides a finger grasp to allow ease of manipulation. Balloon extension leg assembly **33** also
5 comprises a stopcock **34** that is preferably one-way and a luer lock section **37** to receive a balloon inflation/deflation device (not shown).

A third lumen **24** extends preferably from proximal end **6** to a point proximal to stone balloon **12**. Third lumen **24** has a contrast medium distal port **25** situated proximal to stone balloon **12**. In an alternative embodiment (as shown in FIG. 13),
10 distal port **25** can be situated distal to stone balloon **12**. A portion of sheath **4** that forms a proximal end of third lumen **24** is connected to a contrast medium extension leg **38**. Contrast medium extension leg **38** has a lumen **24a** (shown in FIG. 13) that communicates with third lumen **24**. Extension leg **38** has an injection leg assembly **39** that provides a finger grasp to allow ease of manipulation. Injection leg assembly **39**
15 also has a injection luer lock **40** for receiving an injection media infusion device (not shown).

Referring to FIGS. 3-5, tube junction assembly **8** comprises an outer trifurcate snap cover **43** adapted to secure sheath **4** to extension legs **30**, **32** and **38**. Snap cover **43** has a reduced diameter snap cover distal end **44** adapted to fit snugly about
20 sheath **4**. A tapered collar **46** connects snap cover distal end **44** to a main snap cover body **48**. A proximal end of snap cover **43** is enclosed by a snap cap **50** that has an axial bore (not shown) to receive extension legs **30**, **32** and **38**. Snap cap **50** is preferably bonded to snap cover **43** with Loctite® adhesive **54**. A polyolefin shrink tube **52** is provided about proximal end **6** of sheath **4** and the distal ends of extension
25 legs **30**, **32** and **38**. Shrink tube **52** is heated onto the sheath and extension legs such that the materials of the components become integrated to form a seamless connection between sheath **4** and leg extensions **30**, **32** and **38**.

In a preferred embodiment, the wall thickness (interluminal and outside walls), of a main shaft of sheath **4** is maintained to a minimum of about .006". The wall
30 thickness of distal end **9** is maintained to a minimum of about .004". These values

-8-

are essential to maintain acceptable mechanical characteristics of pushability, trackability, stiffness, kinkability, tensile strength and elongation. I have discovered that these wall thickness can be maintained while maximizing the cross-sectional area of third lumen **38**, the contrast media lumen, that provides enhanced contrast media flow through catheter **1**. To optimize the flow of contrast media, the diameter of first lumen **20** was reduced to about .041" in the main shaft and .037" minimum in the tip length that is sufficient to allow for the free movement of a guide wire **60** through first lumen **20**.

Second lumen **22**, the balloon inflation/deflation lumen, was also reduced in diameter without any appreciable effect on the inflation or deflation rates. This downsizing provided more space to enlarge third lumen **38**, the contrast media lumen. To ensure desired flow, the diameter of the proximal end of second lumen **22** is maintained to allow for the insertion of a .014 inch diameter pin. The cross-sectional shape of second lumen **22** does not have to be maintained circular but may take on other irregular or regular shapes such as an oval

I discovered that a cross-sectional shape that conforms to a kidney shape for third lumen **38** in the main shaft (the portion of sheath **4** that does not include the tapered distal end), of sheath **4** maximized the flow rate of contrast medium in the third lumen. The kidney shaped lumen is shown in FIG. 12. I also discovered that a cross-sectional shape that conforms to a crescent shape for third lumen **38** in distal end **9** of sheath **4** maximized contrast media flow rates in that portion of sheath **4** while maintaining the set minimum wall thickness. The crescent shaped lumen is shown in FIG. 11.

To demonstrate the efficacy of the invention, a comparison test was run with prior art products. Prior art triple lumen catheter A is shown in FIG. 14. Prior art triple lumen catheter B is shown in FIG. 15. The invention catheter is shown in FIGS. 11 and 12. All three have 7 French main body outer diameters that reduce down to 5 French distal tip outer diameters. Each has an 11.5 mm balloon attached proximal to the distal ends of the catheters. As is clearly seen in the figures, the invention

catheter has the smallest cross-sectional area for the balloon inflation lumen and the largest cross-sectional area for the contrast media lumen.

To test balloon inflation/deflation rates, 1.5 cc of air was infused into the 11.5 mm balloons with a preloaded syringe. Three test runs were made with the prior art balloon catheters and over thirty runs were made with the invention balloon catheter. Prior art catheter A had a mean inflation rate of 1.18 seconds with a standard deviation of 0.13. Prior art catheter B had a mean inflation rate of 0.92 seconds with a standard deviation of 0.13. The invention catheter had a mean inflation rate of 0.74 seconds with a standard deviation of 0.08.

Prior art catheter A had a mean deflation rate of 1.00 seconds with a standard deviation of 0.03. Prior art catheter B had a mean deflation rate of 0.94 seconds with a standard deviation of 0.14. The invention catheter had a mean deflation rate of 0.57 seconds with a standard deviation of 0.08.

To test contrast lumen injection rates, tests were conducted with water being infused through the contrast lumen at 60 psi. The rate was determined by dividing the amount of water collected at the distal ends of the catheters by the time. Tests were run for versions of balloon catheters having contrast lumen distal ports proximal to the balloon and versions having distal ports distal to the balloon.

For versions having contrast lumen distal to the balloon, prior art catheter A had a mean flow rate of 21.7 ml/min. with a mean deviation of 0.6. Prior art catheter B had a mean flow rate of 43.7 ml/min. with a mean deviation of 0.6. The invention catheter had a mean flow rate of 48 ml/min. with a mean deviation of 2.

For the catheter versions having contrast lumen proximal to the balloon, prior art catheter A had a mean flow rate of 23.0 ml/min. with a mean deviation of 1.7. Prior art catheter B had a mean flow rate of 44.3 ml/min. with a mean deviation of 1.5. The invention catheter had a mean flow rate of 52 ml/min. with a mean deviation of 2.

The chart set forth below lists the preferred maximum and minimum cross-sectional areas for the invention triple lumen balloon catheter. It is to be understood that these values are extremes for catheters made with Pebax 7033. Use of other materials may allow for larger maximums and smaller minimums while achieving and maintaining the flow rates and mechanical characteristics set forth herein. Other

materials may also be used to alter the mechanical characteristics, e.g., trackability and kinkability, without altering the desired lumen cross-sectional areas and improved flow rates and without departing from the scope of the invention.

FIG. 16 shows a cross-section of a distal tip of a catheter made in accordance with one embodiment of the invention with the contrast media lumen maximized relative to the balloon lumen and the guide wire lumen. FIG. 17 shows a cross-section of a distal tip of a catheter made in accordance with another embodiment of the invention with the contrast media lumen minimized relative to the balloon lumen and the guide wire lumen. FIG. 18 shows a cross-section of a main shaft of a catheter made in accordance with one embodiment of the invention with the contrast media lumen minimized relative to the balloon lumen and the guide wire lumen. FIG. 19 shows a cross-section of a main shaft of a catheter made in accordance with another embodiment of the invention with the contrast media lumen maximized relative to the balloon lumen and the guide wire lumen. The numbers shown in the drawings are reflected in the chart below.

Catheter Location	Guide wire Lumen (in ²)		Balloon Lumen (in ²)		Contrast Lumen (in ²)	
	Min.	Max.	Min.	Max.	Min.	Max.
Tip Length	1.08×10^3	1.20×10^3	2.83×10^5	9.14×10^5	1.42×10^4	1.07×10^3
Main Shaft	1.19×10^3	1.59×10^3	1.13×10^4	2.07×10^4	3.48×10^4	3.15×10^3

The desired lumen geometric configurations are established by varying the pressures in the different lumen when sheath 4 is manufactured using an extrusion process. Altering the pressure differentials in the lumens during the extrusion process produces varied geometric cross-sections. One set of pressure differentials is used in the main shaft while a different set is used in the distal end. This was combined with what is commonly known in the industry as the "bump" tubing extrusion process to

-11-

generate a tapered distal end with cylindrical tip. The tapered distal end is formed by increasing the extrusion speed at the appropriate point in the formation of sheath 4.

Those of skill in the art will appreciate that the process is a dynamic one that cannot be operated at a constant set point throughout the process. Multipoint output speed controls allow for the smooth transition of the outside geometry of the sheath that is preferably circular in cross section. Multipoint pressure controls are essential to obtain the desired cross sectional areas and geometries of the three lumens.

To illustrate the process, to make the crescent shaped contrast media lumen in the distal end, the pressure in the guide wire lumen is slightly decreased from the pressure used in the main shaft which is approximately from about 3 to 8 inches of H₂O and preferably from about 4 to about 6 inches of H₂O to achieve a drop in inner diameter of from .041 inches to .037 inches. The pressure in the balloon inflation lumen was reduced to close to zero without any adverse results to the dimensional integrity of the balloon inflation lumen in the distal end. The pressure in the contrast medium lumen was slightly increased within the range of approximately from about 3 to about 8 inches of H₂O and preferably from about 4 to about 6 inches of H₂O. The shift in relative lumen pressures resulted in the contrast medium lumen migrating into the areas previously occupied by the balloon lumen.

Those of ordinary skill in the art will be familiar with the chemical compositions, materials and methods used to make such catheters. It is to be understood that the composition of sheath 4 does not form part of the invention. The materials described herein are merely for illustrative purposes.

It is to be appreciated that due to variances from batch to batch of a selected material and variances among different materials, some experimentation is required with respect to the pressure and speed settings to achieve the desired geometric configurations described herein. The pressure ranges set forth herein are for the disclosed Pebax material. Alternative ranges may be required for different materials to achieve the desired geometric configurations. The key to formation of the desired geometric configurations lies with the balance of pressure differentials in the various lumen at any given point along the extrusion process as well as pressure alteration in the individual lumen as the extrusion progresses.

-12-

The apparatus shown in FIG. 10 is used to make sheath 4. The process begins by placing resin 68 in a resin dryer 70 that has a hollow chamber 71 for receiving resin 68. Resin 68 is maintained in dryer 70 overnight to remove any moisture present in the resin. Dryer 70 is attached to a heating chamber 72 having a hollow portion 73 for receiving a screw feed 74. Screw feed 74 rotates within heating chamber 72. Hollow portion 73 is in communication with hollow chamber 71. Screw feed 74 has a proximal end 75, the pre-screw feed end, that is set at a first temperature, a middle screw feed section 76, the mid-screw section, that is set at a second temperature and a distal screw feed end 77, the extrusion die end, that is set at a third temperature. The temperatures are set according to resin melt characteristics as is well known in the art.

To form the three lumen, three high speed, ultra low pressure air controllers, first air controller 80, second air controller 81 and third air controller 82 are attached to a three lumen extrusion die 90 and a program controller 92. Custom software is loaded into program controller 92 and controls five outputs—processing speed, the pressure in the three lumens and the length of the finished product. The Program controller has twenty-two adjustment points for the five output settings.

The heated resin 68 is fed through extrusion die 90. The formed catheter is then placed in a water bath 100 to cool the extruded catheter sheath. The sheath is then fed by rollers 104 past a computer operated cut-off blade 102 that cuts the tube into predetermined lengths. The severed catheter lengths are dropped into a tray 106 where the catheters can be gathered for further assembly.

To initiate the process, an extrusion run is commenced and dimensional samples are taken to determine whether the desired dimensional parameters are being met. Adjustments are made to the apparatus until the desired dimensions are obtained. The extrusion run is dimensionally monitored throughout the run. Data is submitted with each lot to ensure consistency and acceptability of the product.

The inventive catheter described herein may be used in the following manner to evaluate, for example, a bile duct site and to position a balloon for treating a stricture or obstruction. An endoscope such as a duodenoscope is advanced through

-13-

the alimentary track to the Papilla of Vater. A .035 inch guide wire is advanced through the working channel of the endoscope, out the endoscope's distal end and advanced through the Papilla of Vater into the common bile duct. A proximal end of the guide wire is inserted into a distal port of the guide wire lumen of catheter 1.

5 Catheter 1 is advanced along the guide wire and through the endoscope working channel until positioned in the common bile duct or other desired duct. Alternatively, the guide wire can be preloaded into the catheter and the combination of the catheter and guide wire can be advanced through the endoscope to the desired duct site. Contrast media can then be infused through the novel contrast media lumen to enable
10 visualization of the duct anatomy and contents and to adjust the catheter's positioning with respect to any potential duct occlusions or stones. Once positioning of the balloon has been finalized via the radiopaque markers, the contrast media or a combination of both, inflation media is infused through the balloon inflation/deflation lumen to expand the balloon. The catheter is then manipulated to remove the
15 obstruction or stricture.

The techniques used to operate the catheter are those that are common in the art. The primary difference is the ease with which contrast media can be infused into a desired site due to the unique combination of lumen geometries and cross-sectional areas.

20 It is to be understood that the foregoing description of the invention is intended merely to be illustrative thereof and that other modifications, embodiments and equivalents may be apparent to those who are skilled in the art without departing from its spirit. Having thus described the invention what I claim as new and desire to secure by United States letters patent is:

25

-14-

CLAIMS

1. A triple lumen stone balloon catheter comprising:
 - a sheath comprising a sheath main body and a sheath distal end extending distally from the main body;
 - 5 a first lumen formed in the sheath wherein a first portion of the first lumen extends at least partially through the main body and has a kidney shape in cross section and wherein a second portion of the first lumen extends at least partially through the distal end and has a crescent shape in cross section;
 - a second lumen extending at least partially through the main body and
 - 10 partially through the distal end;
 - a third lumen extending at least partially through the main body and partially through the distal end; and,
 - a balloon attached about the distal end.
- 15 2. The catheter of claim 1 wherein the distal end is tapered with the taper decreasing in a distal direction.
3. The catheter of claim 1 wherein the cross-sectional area of the first portion of the first lumen is from about 3.48×10^4 to about 3.15×10^3 .
- 20 4. The catheter of claim 1 wherein the cross-sectional area of the second portion of the first lumen is from about 1.42×10^4 to about 1.07×10^3 .
5. The catheter of claim 1 wherein the second lumen has a first portion that
- 25 extends at least partially through the main body and a second portion that extends at least partially through the distal end.
6. The catheter of claim 5 wherein the first portion of the second lumen has a cross-sectional area from about 1.13×10^4 to about 2.07×10^4 .
- 30

-15-

7. The catheter of claim 5 wherein the second portion of the second lumen has a cross-sectional area from about 2.83×10^5 to about 9.14×10^5 .

8. The catheter of claim 1 wherein the third lumen has a first portion that extends at least partially through the main body and a second portion that extends at least partially through the distal end.

9. The catheter of claim 8 wherein the first portion of the third lumen has a cross-sectional area from about 1.19×10^3 to about 1.59×10^3 .

10. The catheter of claim 8 wherein the second portion of the third lumen has a cross-sectional area from about 1.08×10^3 to about 1.20×10^3 .

11. The catheter of claim 1 wherein the main body has an external wall and interluminal walls wherein the external and interluminal walls have a minimum thickness of about .006 inches.

12. The catheter of claim 1 wherein the distal end has an external wall and interluminal walls wherein the external and interluminal walls have a minimum thickness of about .004 inches.

13. A triple lumen stone balloon catheter comprising:
a sheath comprising a sheath main body and a sheath distal end extending distally from the main body;

a first lumen formed in the sheath wherein a first portion of the first lumen extends at least partially through the main body and has a kidney shape in cross section and a cross-sectional area from about 3.48×10^4 to about 3.15×10^3 and, wherein a second portion of the first lumen extends at least partially through the distal end and has a crescent shape in cross section and has a cross-sectional area from about 1.42×10^4 to about 1.07×10^3 ;

-16-

a second lumen extending at least partially through the main body and partially through the distal end;

a third lumen extending at least partially through the main body and partially through the distal end; and,

5 a balloon attached about the distal end.

14. The catheter of claim 14 wherein the second lumen has a first portion that extends at least partially through the main body and a second portion that extends at least partially through the distal end wherein the cross-sectional area of the
10 first portion of the second lumen is from about 1.13×10^4 to about 2.07×10^4 and the cross-sectional area of the second portion of the second lumen is from about 2.83×10^5 to about 9.14×10^5 .

15 15. The catheter of claim 14 wherein the third lumen has a first portion that extends at least partially through the main body and a second portion that extends at least partially through the distal end wherein the cross-sectional area of the first portion of the third lumen is from about 1.19×10^3 to about 1.59×10^3 and the cross-sectional area of the second portion of the third lumen is from about 1.08×10^3 to about 1.20×10^3 .

20 16. The catheter of claim 15 wherein the main body has an outside wall and interluminal walls and wherein the minimum wall thickness of the outside and interluminal main body walls is about .006 inches.

25 17. The catheter of claim 16 wherein the distal end has an outside wall and interluminal walls and wherein the minimum wall thickness of the outside and interluminal distal end walls is about .004 inches.

30 18. The catheter of claim 17 wherein the main body has an outside diameter of about 7 French and the distal end has an outside diameter of about 5 French.

-17-

19. A sheath comprising:
a sheath main body and a sheath distal end extending distally from the
main body;

5 a first lumen formed in the sheath wherein a first portion of the first
lumen extends at least partially through the main body and has a kidney shape in
cross section and wherein a second portion of the first lumen extends at least partially
through the distal end and has a crescent shape in cross section; and,
a second lumen extending at least partially through the main body and
partially through the distal end.

10

20. The sheath of claim 19 wherein the second lumen has a first portion that
extends at least partially through the main body and has a diameter of about .041
inches and a second portion that extends at least partially through the distal end and
has a diameter of about .037 inches.

15

21. The sheath of claim 19 further comprising a balloon attached about the
distal end.

22. An endoscopic method of evaluating and treating an occluded duct such
20 as the common bile duct comprising the steps of:

providing a balloon catheter having at least three lumens comprising:
a sheath having a main body,
a distal end extending distally from the main body,
a balloon having an inner surface and attached about the distal end,
25 a first lumen for contrast media having a first portion having a kidney
shape in cross section and extending at least partially through the main
body and a second portion having a crescent shape in cross section and extending at
least partially through the distal end;

a second lumen extending at least partially through the main body and
30 partially through the distal end and having a distal port in communication with the
inner surface of the balloon and a proximal port to receive inflation media;

-18-

a third lumen extending at least partially through the main body and at least partially through the distal end wherein the third lumen has a distal port in the distal end and is adapted to receive a guide wire;

providing an endoscope having a working channel;

5 inserting the endoscope into a duct system;

inserting a guide wire into the working channel of the endoscope
positioning the guide wire in the duct system;

placing the guide wire into the distal port of the third lumen and sliding the catheter over the guide wire and through the endoscope;

10 positioning the catheter in the duct system;

infusing contrast media through the first lumen; and,

infusing inflation media into the second lumen to expand the balloon.

23. The method of claim 22 including the step of inserting the guide wire into
15 the third lumen and inserting the combination of the catheter and guide wire into the working channel of the endoscope.

24. The method of claim 22 wherein the first portion of the first lumen has a
cross-sectional area of from about 3.48×10^4 to about 3.15×10^3
20 and, wherein a second portion of the first lumen has a cross-sectional area from
about 1.42×10^4 to about 1.07×10^3 .

25. The method of claim 24 wherein the first portion of the second lumen
cross-sectional area from about 1.13×10^4 to about 2.07×10^4 and the second portion
25 of the second lumen has a cross-sectional area from about 2.83×10^5 to about 9.14×10^5 .

26. The method of claim 25 wherein the first portion of the third lumen has a
cross-sectional area from about 1.19×10^3 to about 1.59×10^3 and the second
30 section of the third lumen has a cross-sectional area from about 1.08×10^3 to about
 1.20×10^3 .

27. The method of claim 26 wherein the main body has an outside wall and interluminal walls and wherein the minimum wall thickness of the outside and interluminal main body walls is about .006 inches.

5

28. The method of claim 27 wherein the distal end has an outside wall and interluminal walls and wherein the minimum wall thickness of the outside and interluminal distal end walls is about .004 inches.

10

29. The method of claim 28 wherein the main body has an outside diameter of about 7 French and the distal end has an outside diameter of about 5 French.

15

30. A triple lumen stone balloon catheter comprising:
a sheath comprising a sheath main body and a sheath distal end
extending distally from the main body;

a first lumen formed in the sheath and adapted to receive a contrast media wherein a first portion of the first lumen extends at least partially through the main body and wherein a second portion of the first lumen extends at least partially through the distal end ;

20

means for enhancing the contrast media flow through the first lumen;
a second lumen extending at least partially through the main body and partially through the distal end;

a third lumen extending at least partially through the main body and partially through the distal end; and,

25

a balloon attached about the distal end.

31. The catheter of claim 30 wherein the distal end is tapered with the taper decreasing in a distal direction.

30

32. The catheter of claim 31 further comprising a plurality of radiopaque marker bands attached about the distal end and spaced equidistant.

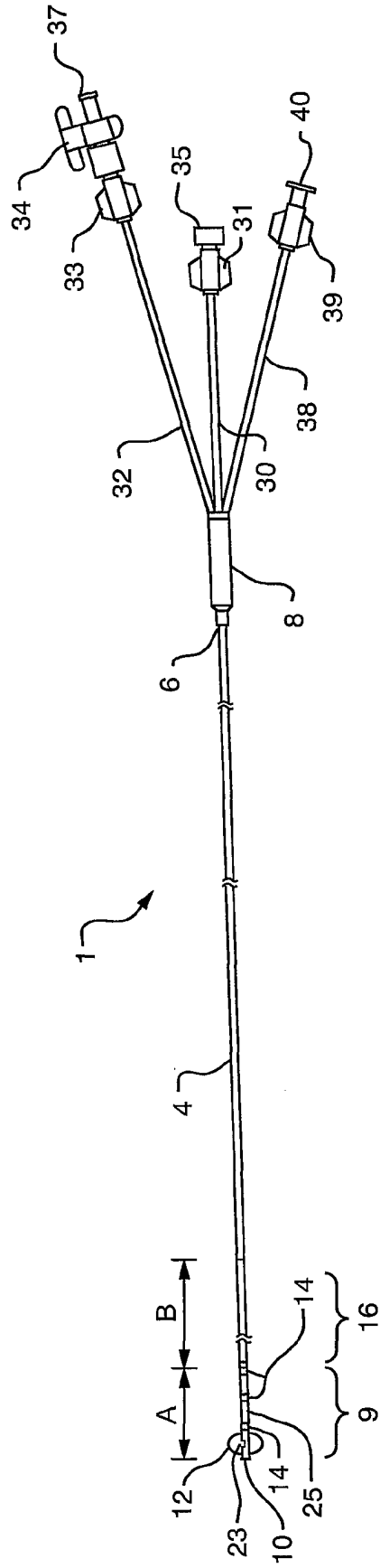

FIG. 1

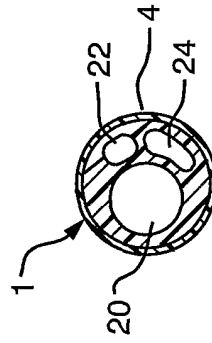

FIG. 2B

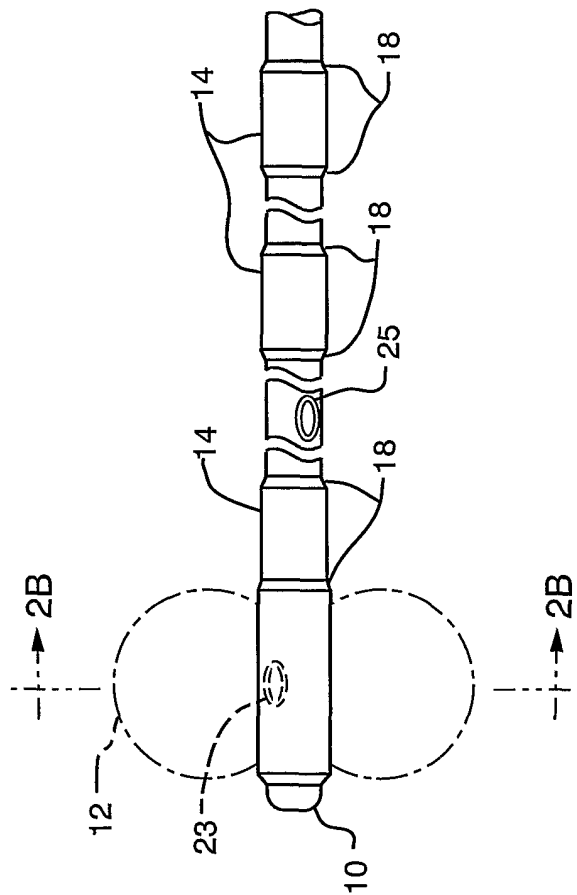

FIG. 2A

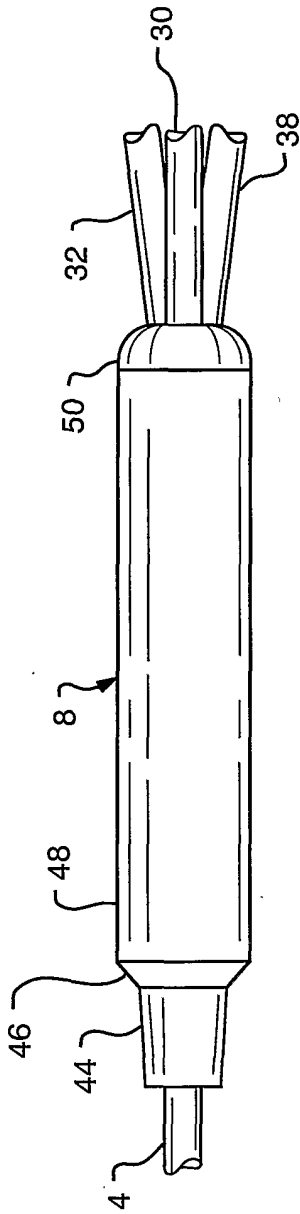

FIG. 3

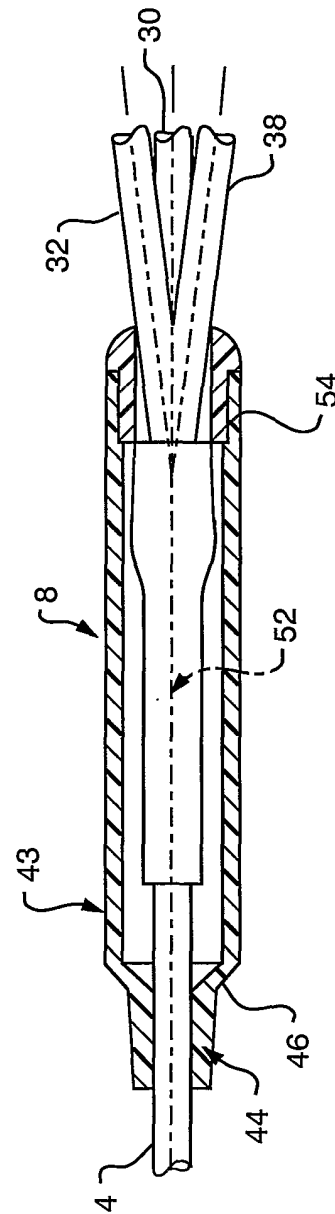

FIG. 4

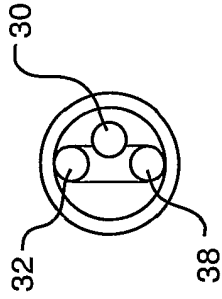

FIG. 5

4/13

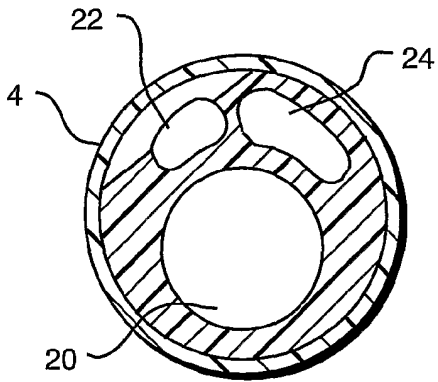

FIG. 6

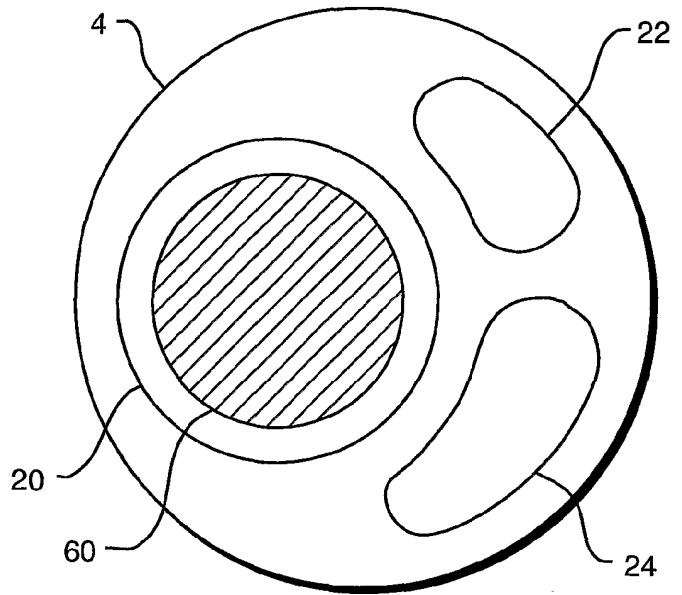

FIG. 7

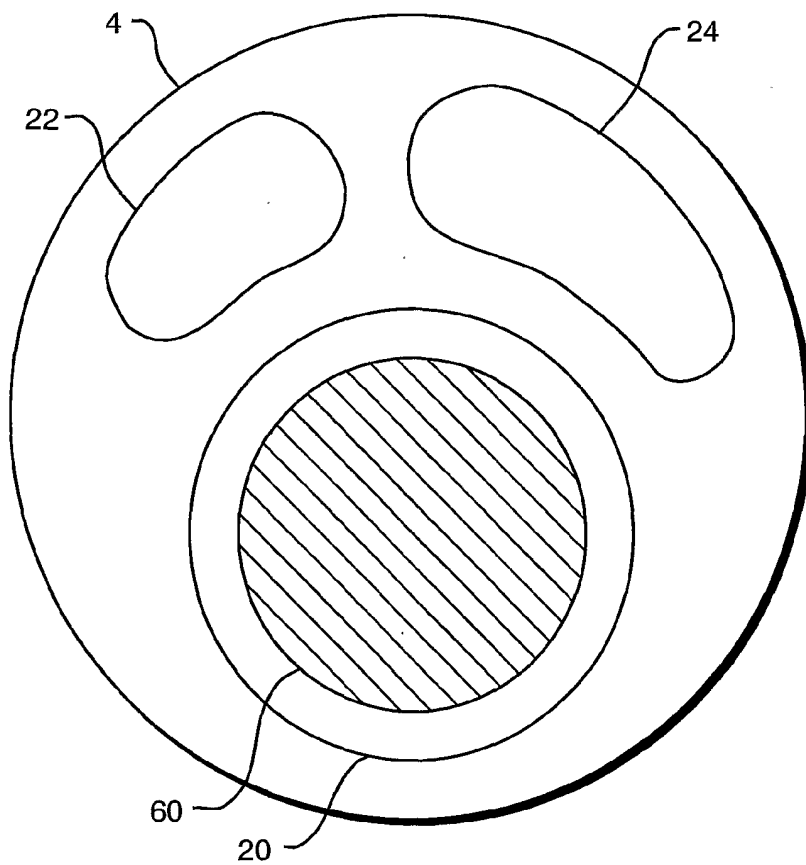

FIG. 8

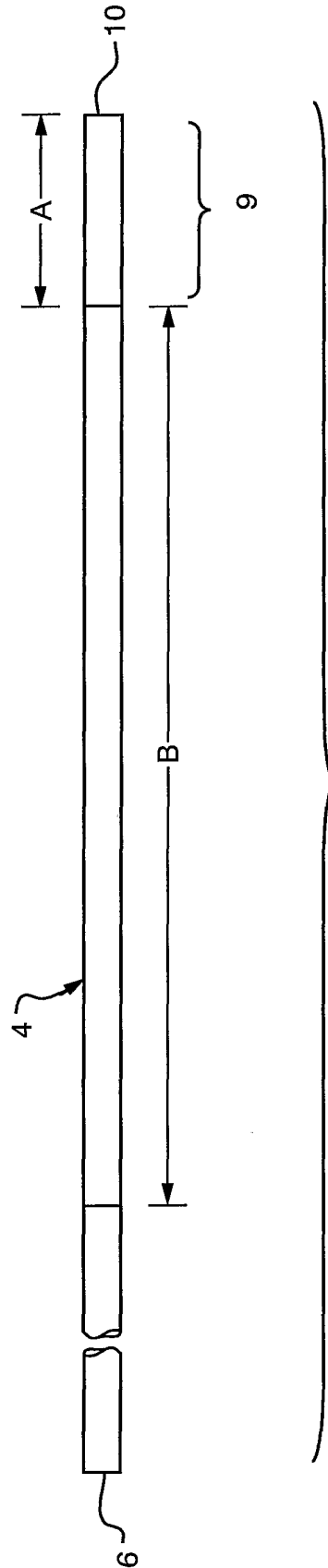

FIG. 9

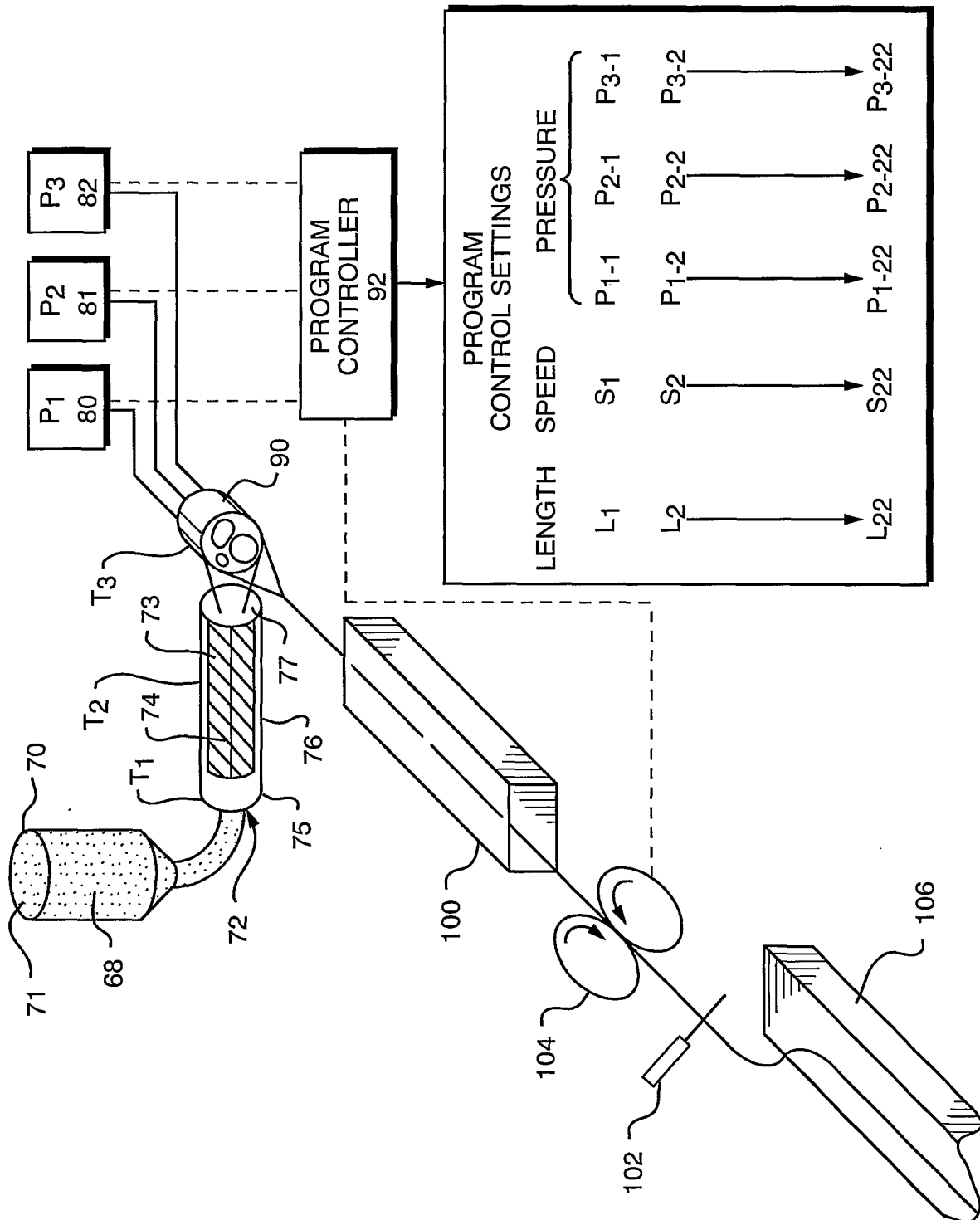

FIG. 10

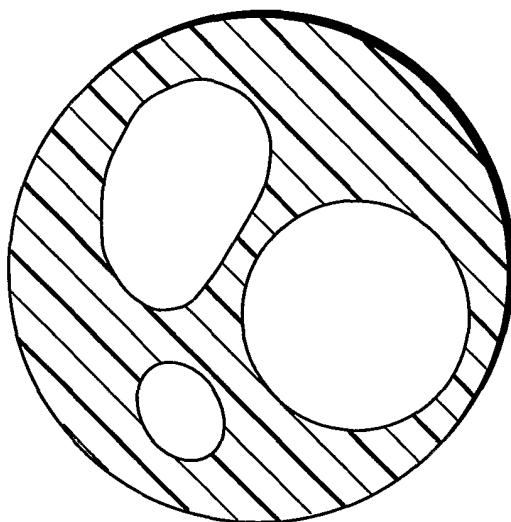

FIG. 12

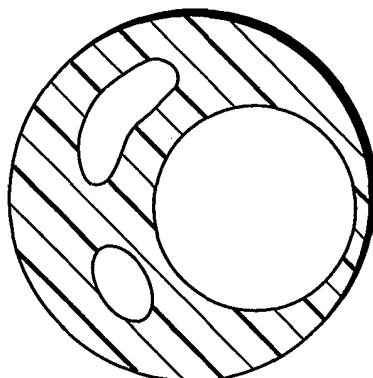

FIG. 11

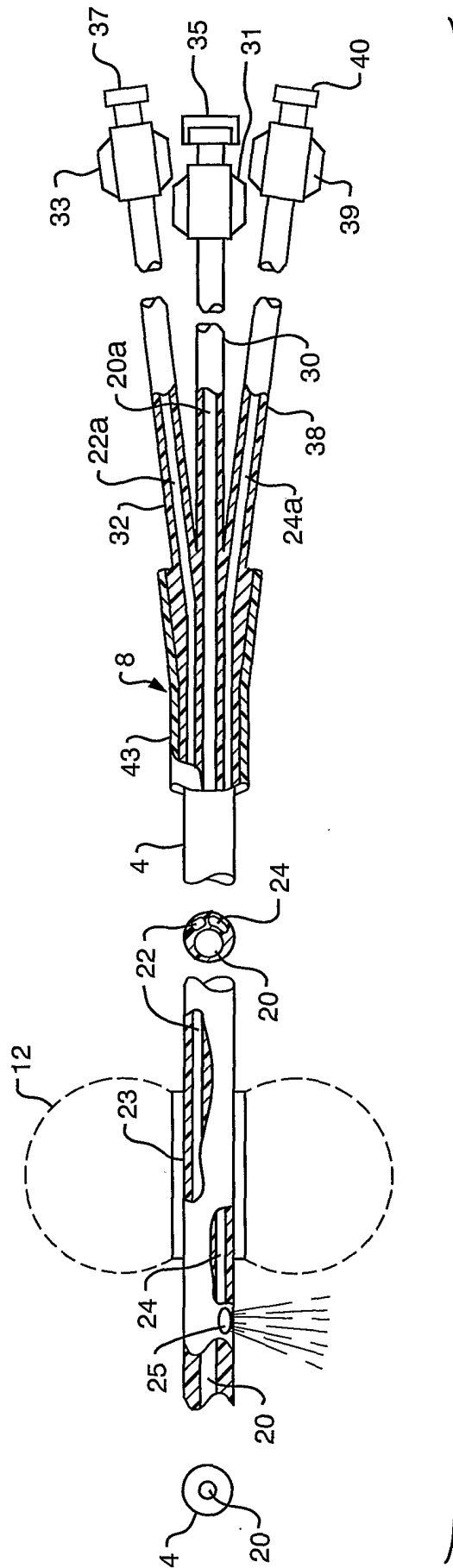

FIG. 13

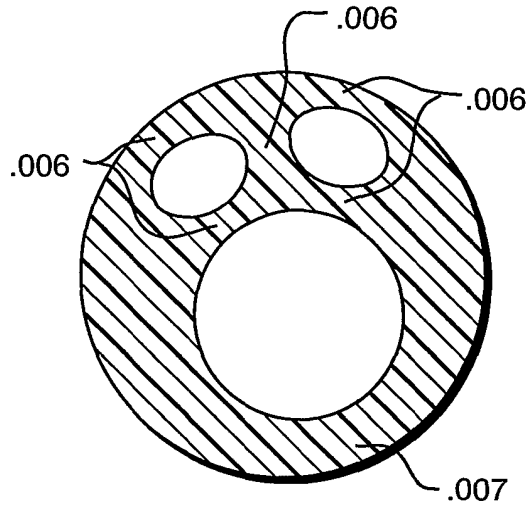

FIG. 14A
(PRIOR ART)

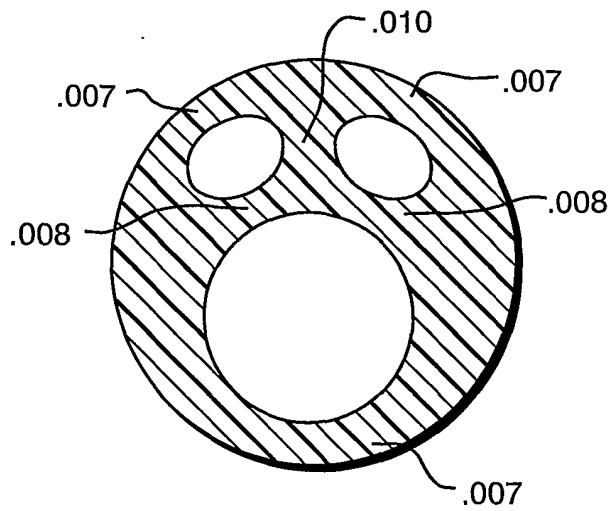

FIG. 14B
(PRIOR ART)

10/13

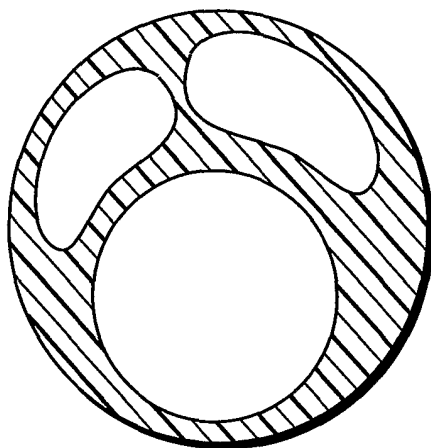

FIG. 15A
(PRIOR ART)

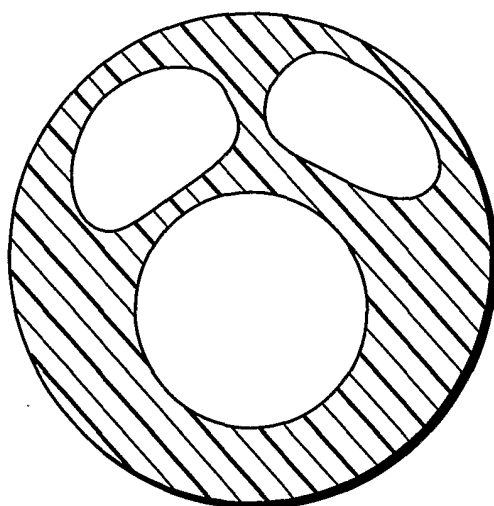

FIG. 15B
(PRIOR ART)

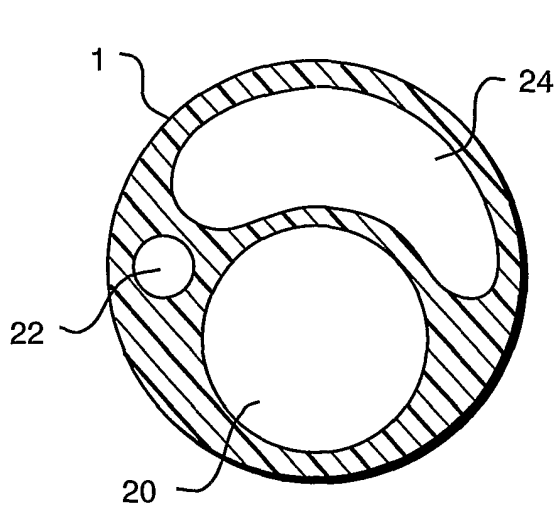

FIG. 16

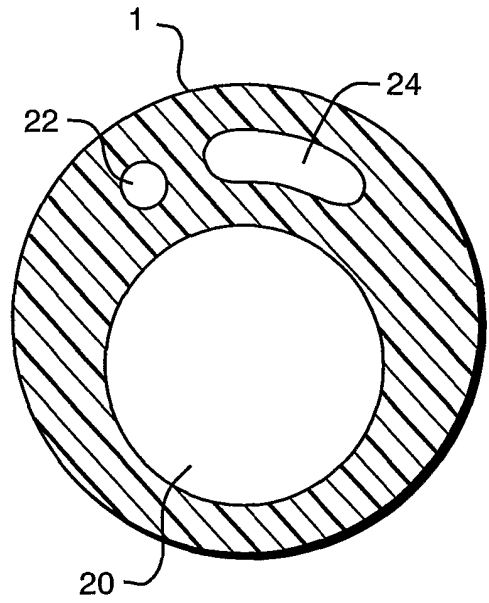

FIG. 17

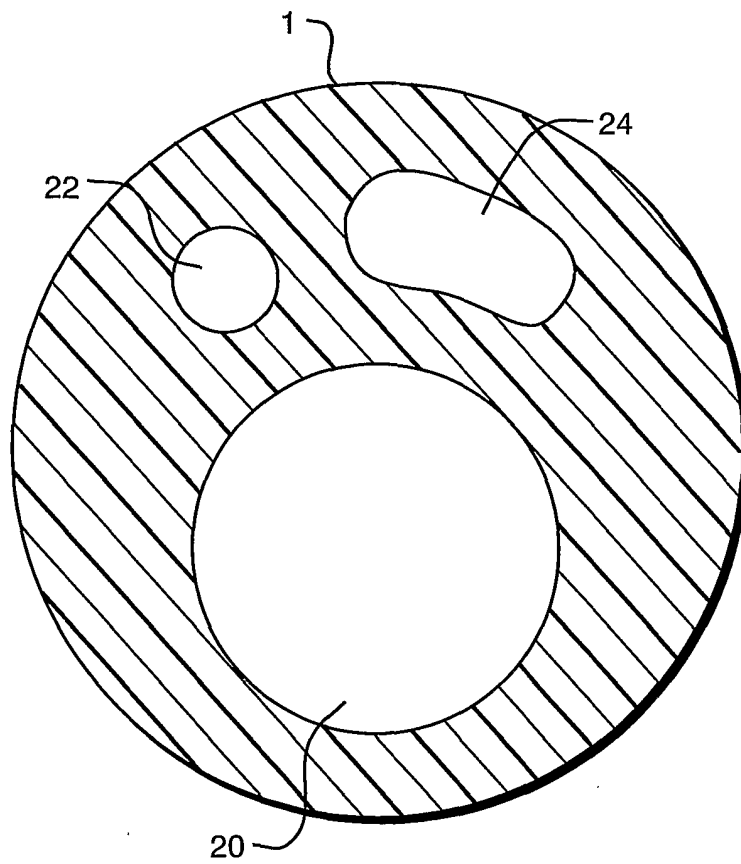

FIG. 18

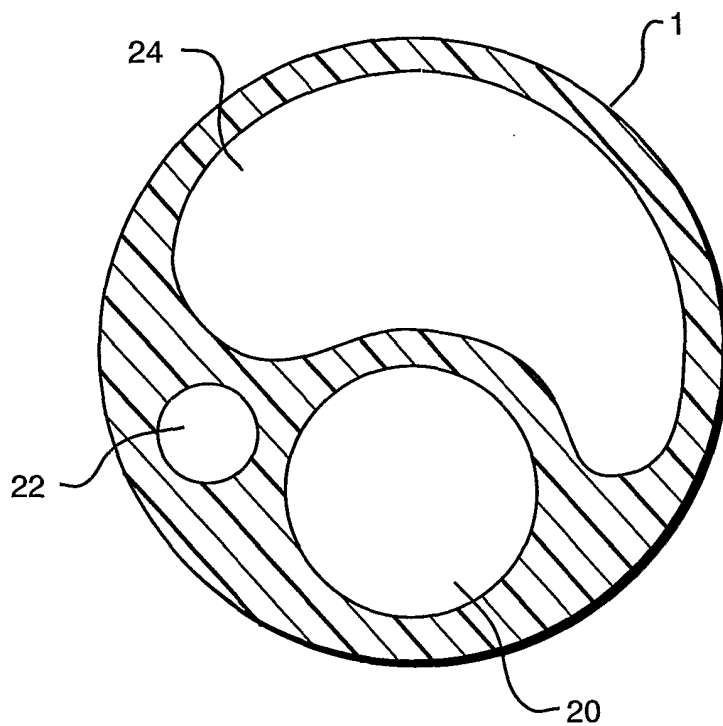

FIG. 19

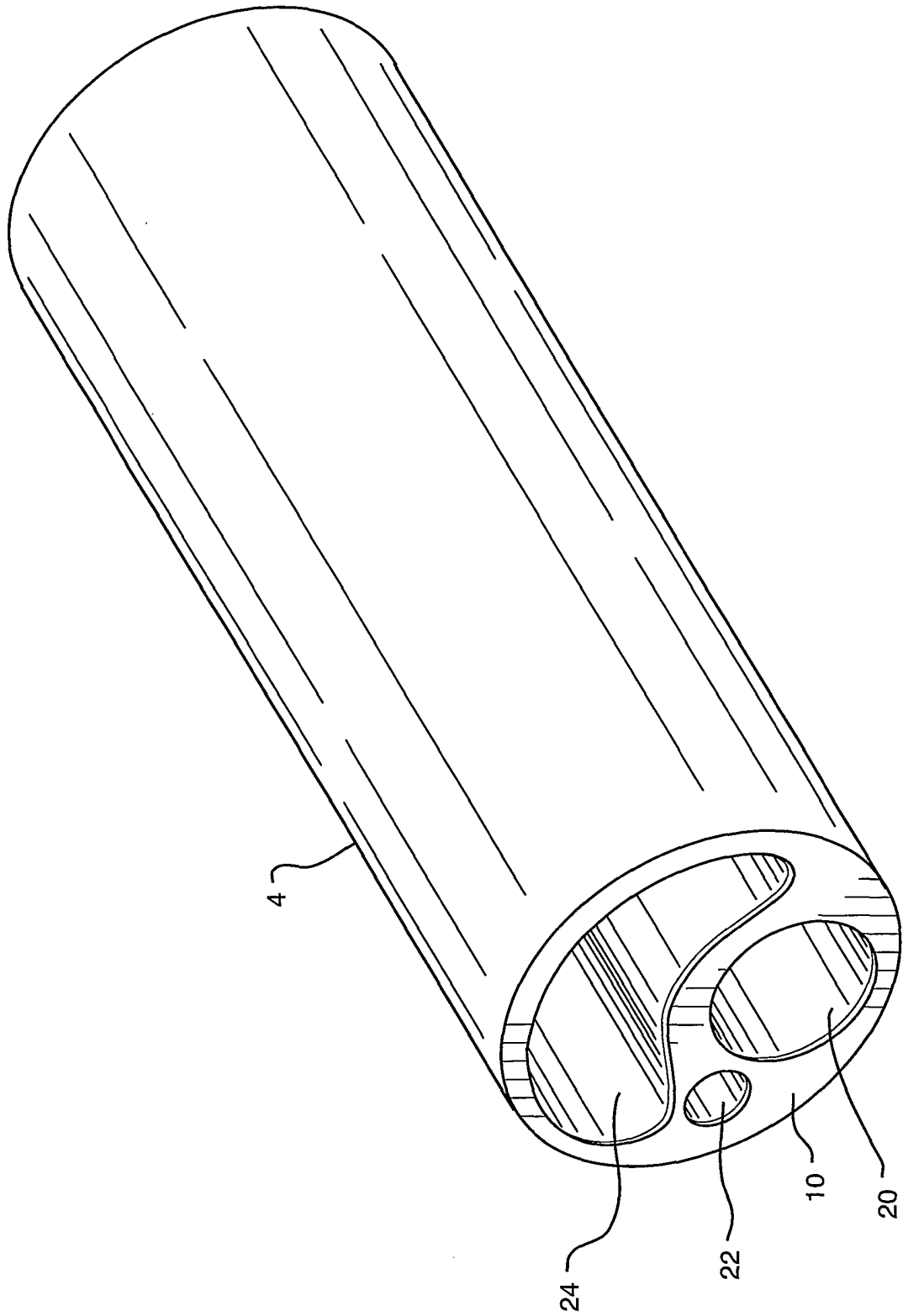

FIG. 20

INTERNATIONAL SEARCH REPORT

International application No.
PCT/US01/03621

<p>A. CLASSIFICATION OF SUBJECT MATTER IPC(7) :A61M 25/00 US CL :604/264 According to International Patent Classification (IPC) or to both national classification and IPC</p>																				
<p>B. FIELDS SEARCHED Minimum documentation searched (classification system followed by classification symbols) U.S. : 604/264, 506-510, 500, 96.01, 102.01, 102.03, 103.1, 523, 528, 533-535, 284; 606/192, 194 Documentation searched other than minimum documentation to the extent that such documents are included in the fields searched Electronic data base consulted during the international search (name of data base and, where practicable, search terms used)</p>																				
<p>C. DOCUMENTS CONSIDERED TO BE RELEVANT</p> <table border="1"> <thead> <tr> <th>Category*</th> <th>Citation of document, with indication, where appropriate, of the relevant passages</th> <th>Relevant to claim No.</th> </tr> </thead> <tbody> <tr> <td>Y</td> <td>US 5,916,193 A (STEVENS et al) 29 June 1999, Figures 16-24, col. 17-19.</td> <td>1-21,30,31</td> </tr> <tr> <td>Y</td> <td>US 4,961,809 A (MARTIN) 09 October 1990, figures 4-5.</td> <td>1-21,30,31</td> </tr> <tr> <td>Y</td> <td>US 5,876,426 A (KUME et al) 02 March 1999, figure 1.</td> <td>32,33</td> </tr> </tbody> </table>			Category*	Citation of document, with indication, where appropriate, of the relevant passages	Relevant to claim No.	Y	US 5,916,193 A (STEVENS et al) 29 June 1999, Figures 16-24, col. 17-19.	1-21,30,31	Y	US 4,961,809 A (MARTIN) 09 October 1990, figures 4-5.	1-21,30,31	Y	US 5,876,426 A (KUME et al) 02 March 1999, figure 1.	32,33						
Category*	Citation of document, with indication, where appropriate, of the relevant passages	Relevant to claim No.																		
Y	US 5,916,193 A (STEVENS et al) 29 June 1999, Figures 16-24, col. 17-19.	1-21,30,31																		
Y	US 4,961,809 A (MARTIN) 09 October 1990, figures 4-5.	1-21,30,31																		
Y	US 5,876,426 A (KUME et al) 02 March 1999, figure 1.	32,33																		
<p><input type="checkbox"/> Further documents are listed in the continuation of Box C. <input type="checkbox"/> See patent family annex.</p>																				
<table border="0"> <tr> <td>* Special categories of cited documents:</td> <td>"T"</td> <td>later document published after the international filing date or priority date and not in conflict with the application but cited to understand the principle or theory underlying the invention</td> </tr> <tr> <td>"A" document defining the general state of the art which is not considered to be of particular relevance</td> <td>"X"</td> <td>document of particular relevance; the claimed invention cannot be considered novel or cannot be considered to involve an inventive step when the document is taken alone</td> </tr> <tr> <td>"E" earlier document published on or after the international filing date</td> <td>"Y"</td> <td>document of particular relevance; the claimed invention cannot be considered to involve an inventive step when the document is combined with one or more other such documents, such combination being obvious to a person skilled in the art</td> </tr> <tr> <td>"L" document which may throw doubts on priority claim(s) or which is cited to establish the publication date of another citation or other special reason (as specified)</td> <td>"&"</td> <td>document member of the same patent family</td> </tr> <tr> <td>"O" document referring to an oral disclosure, use, exhibition or other means</td> <td></td> <td></td> </tr> <tr> <td>"P" document published prior to the international filing date but later than the priority date claimed</td> <td></td> <td></td> </tr> </table>			* Special categories of cited documents:	"T"	later document published after the international filing date or priority date and not in conflict with the application but cited to understand the principle or theory underlying the invention	"A" document defining the general state of the art which is not considered to be of particular relevance	"X"	document of particular relevance; the claimed invention cannot be considered novel or cannot be considered to involve an inventive step when the document is taken alone	"E" earlier document published on or after the international filing date	"Y"	document of particular relevance; the claimed invention cannot be considered to involve an inventive step when the document is combined with one or more other such documents, such combination being obvious to a person skilled in the art	"L" document which may throw doubts on priority claim(s) or which is cited to establish the publication date of another citation or other special reason (as specified)	"&"	document member of the same patent family	"O" document referring to an oral disclosure, use, exhibition or other means			"P" document published prior to the international filing date but later than the priority date claimed		
* Special categories of cited documents:	"T"	later document published after the international filing date or priority date and not in conflict with the application but cited to understand the principle or theory underlying the invention																		
"A" document defining the general state of the art which is not considered to be of particular relevance	"X"	document of particular relevance; the claimed invention cannot be considered novel or cannot be considered to involve an inventive step when the document is taken alone																		
"E" earlier document published on or after the international filing date	"Y"	document of particular relevance; the claimed invention cannot be considered to involve an inventive step when the document is combined with one or more other such documents, such combination being obvious to a person skilled in the art																		
"L" document which may throw doubts on priority claim(s) or which is cited to establish the publication date of another citation or other special reason (as specified)	"&"	document member of the same patent family																		
"O" document referring to an oral disclosure, use, exhibition or other means																				
"P" document published prior to the international filing date but later than the priority date claimed																				
Date of the actual completion of the international search 06 JUNE 2001		Date of mailing of the international search report 28 JUN 2001																		
Name and mailing address of the ISA/US Commissioner of Patents and Trademarks Box PCT Washington, D.C. 20231 Facsimile No. (703) 305-3230		Authorized officer CRIS L. RODRIGUEZ <i>Diane Smith f</i> Telephone No. (703) 308-2194																		