



US 20060207905A1

(19) **United States**

(12) **Patent Application Publication**
Whiteside

(10) **Pub. No.: US 2006/0207905 A1**

(43) **Pub. Date: Sep. 21, 2006**

(54) **MULTISTRAP CONTAINER PACKAGE SYSTEM**

(52) **U.S. Cl. 206/434**

(76) **Inventor: Michael G. Whiteside, Barrie (CA)**

Correspondence Address:
D.W. EGGINS
18 DOWNSVIEW DRIVE
BARRIE, ON L4M 4P8 (CA)

(57) **ABSTRACT**

(21) **Appl. No.: 11/082,984**

(22) **Filed: Mar. 18, 2005**

Publication Classification

(51) **Int. Cl.**
B65D 65/00 (2006.01)
B65D 75/00 (2006.01)

Low bulk cardboard transit packaging suitable for shipping glass containers to a manufacturer, and for re-use with the filled containers in shipping to the retailer, and for retail display purposes, as well as use with plastic and metal parallel wall containers, uses at least two peripheral holding straps to secure the package with its contents, and container locating means in a multi-pack embodiment including chimes and/or frangible glue fasteners to immobilize selected ones of the containers. Some package embodiments use paperboard sheet.

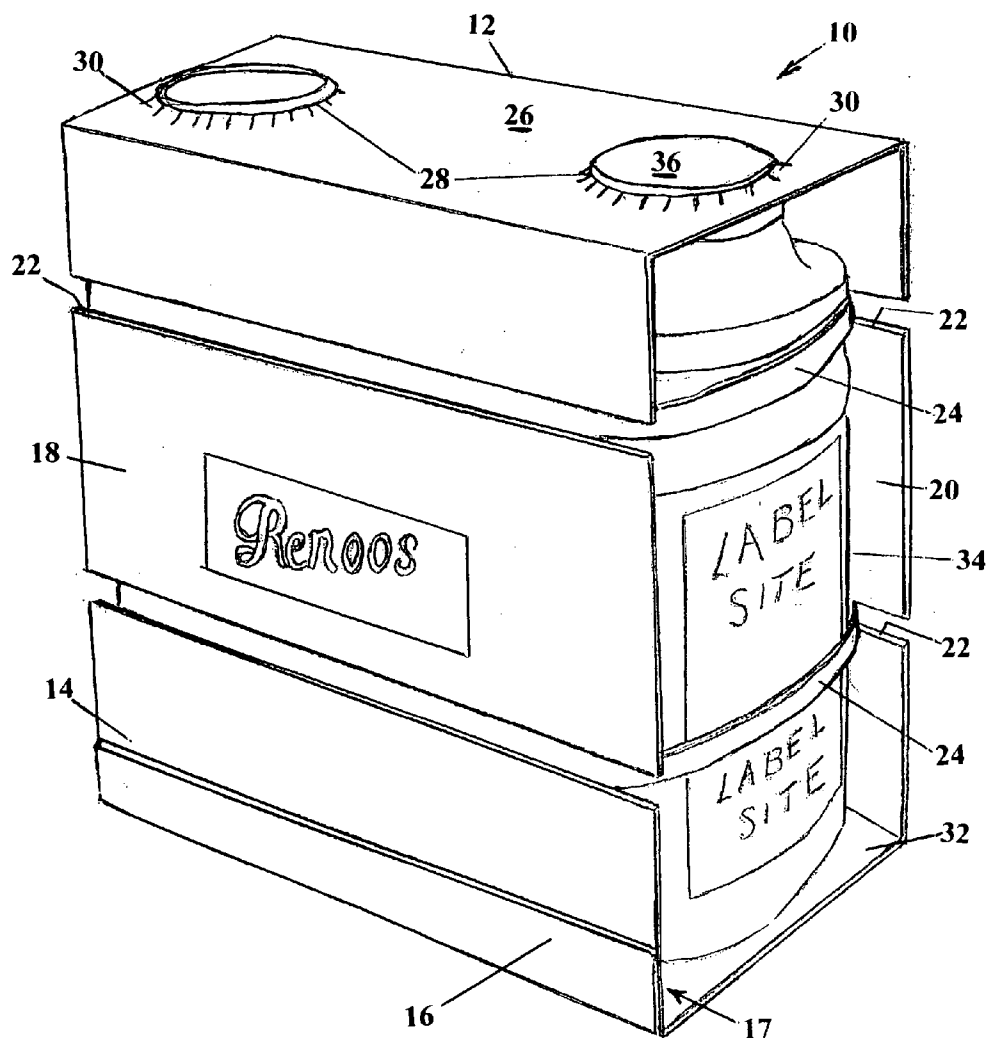
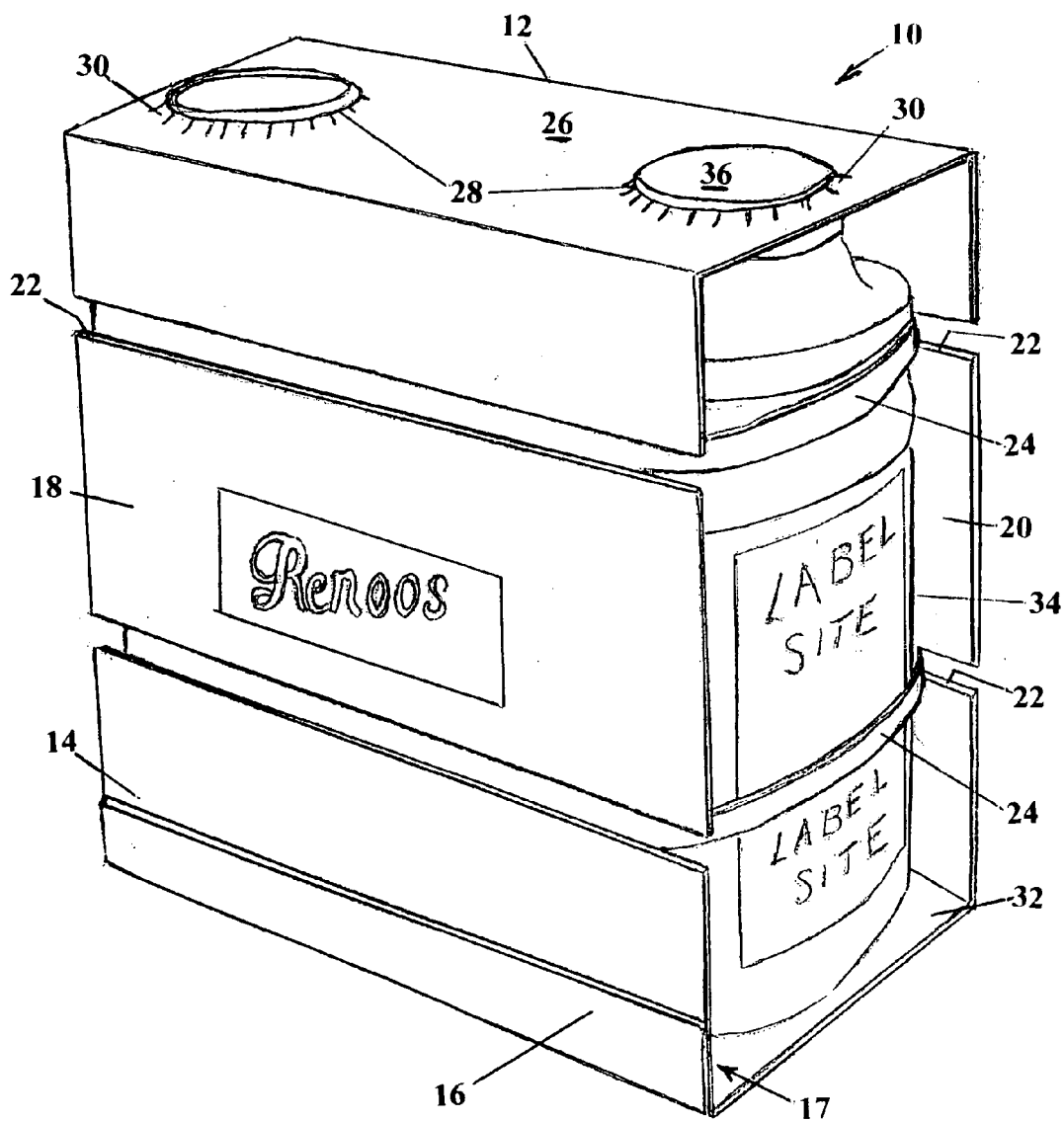

FIG 1



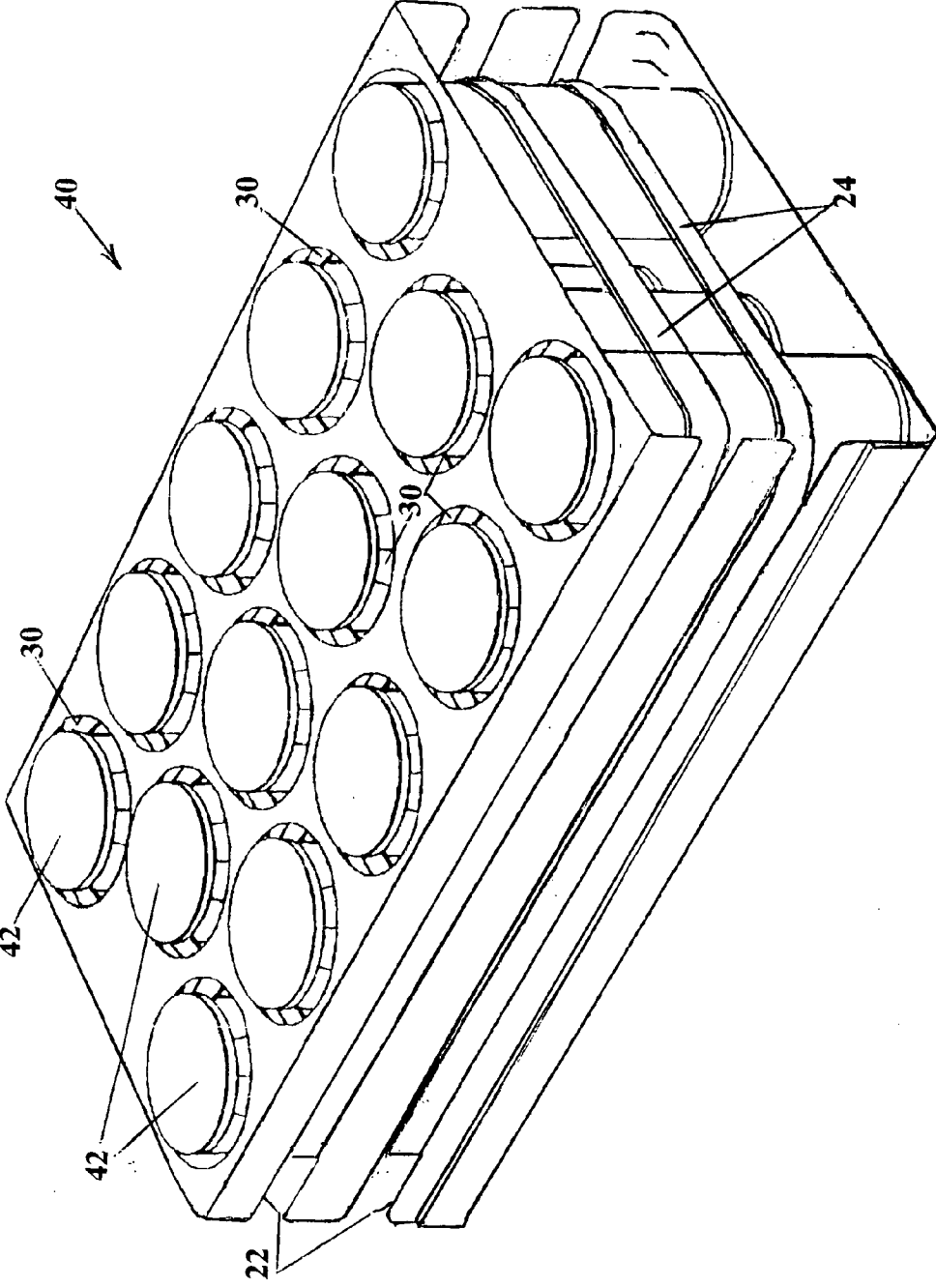

FIG 2

FIG 3

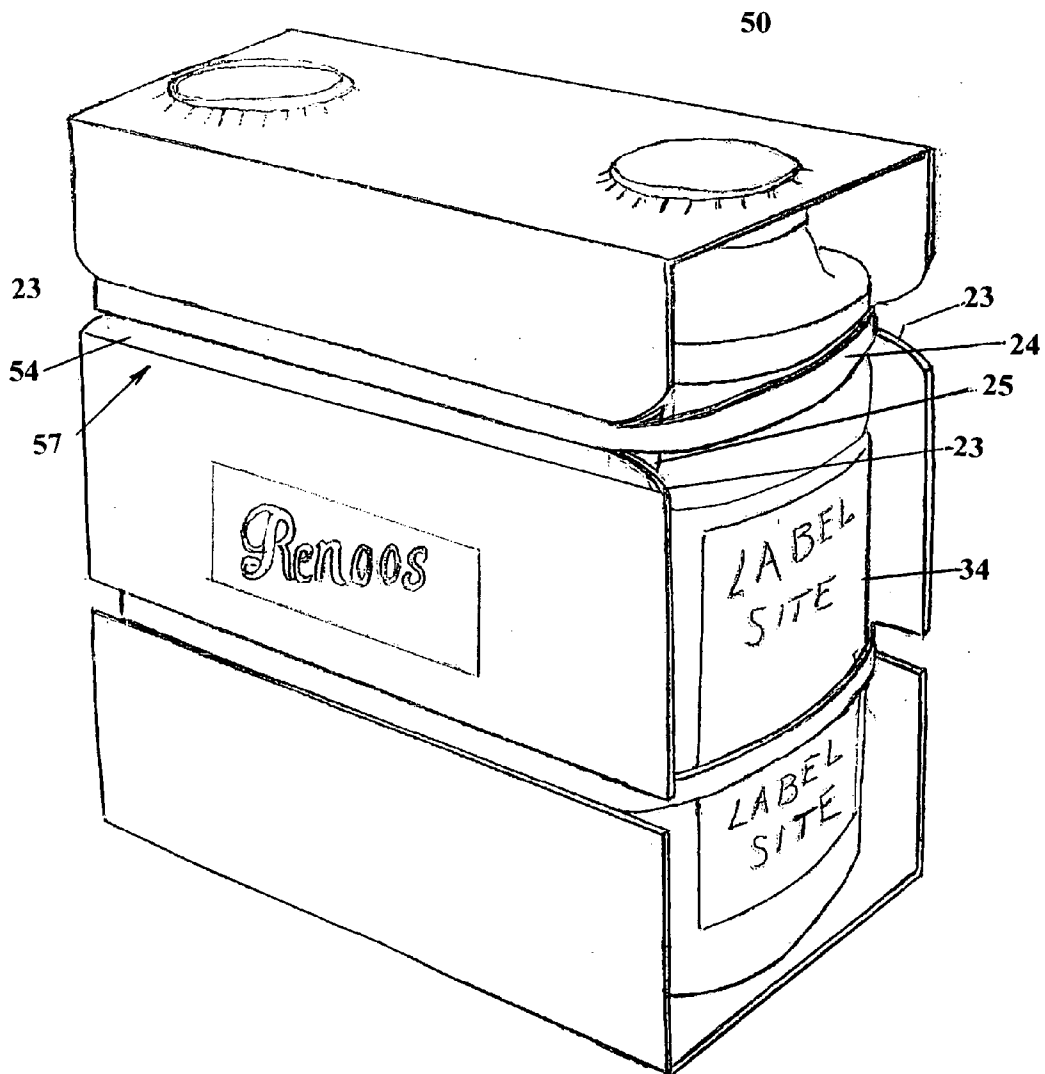
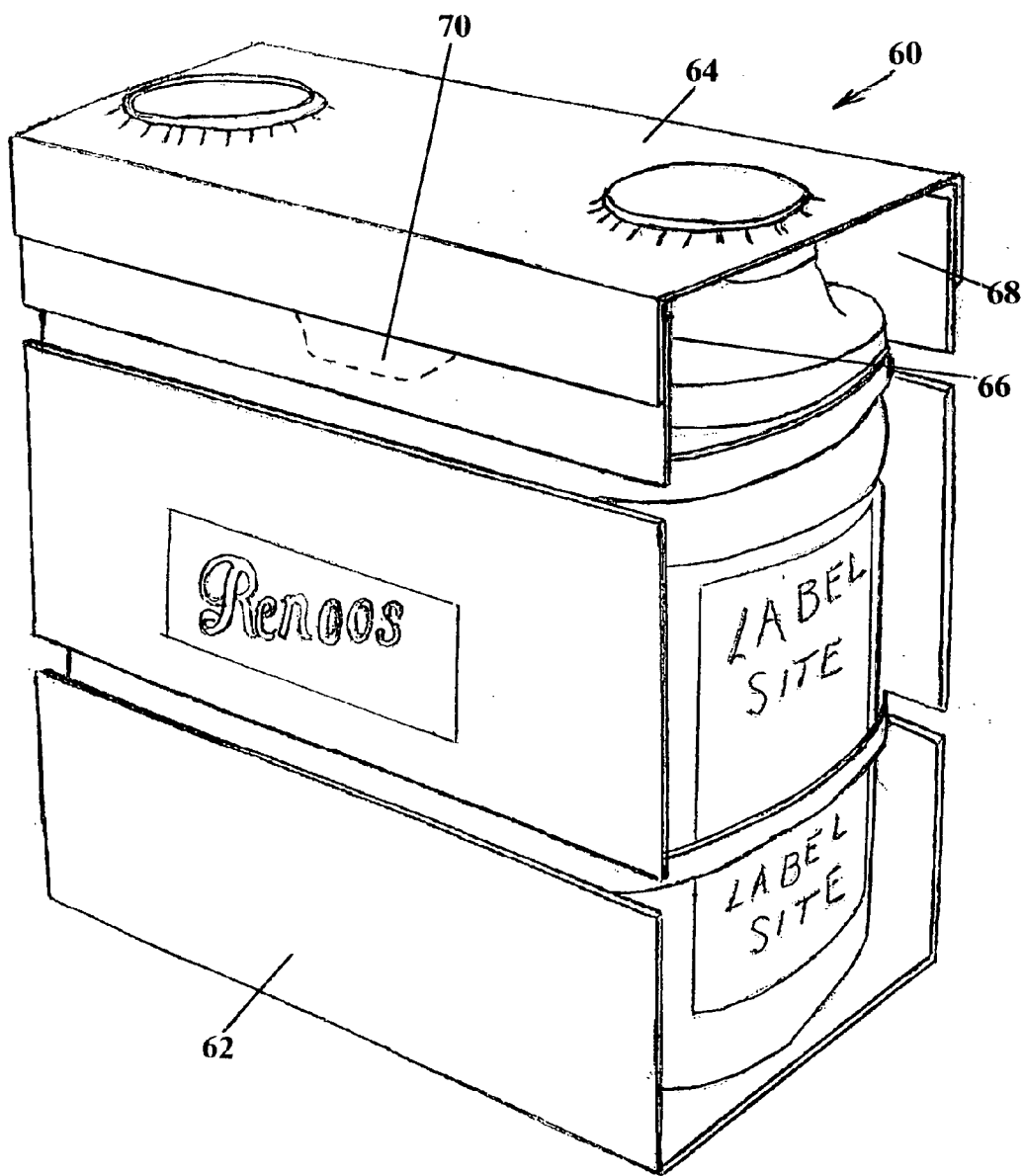
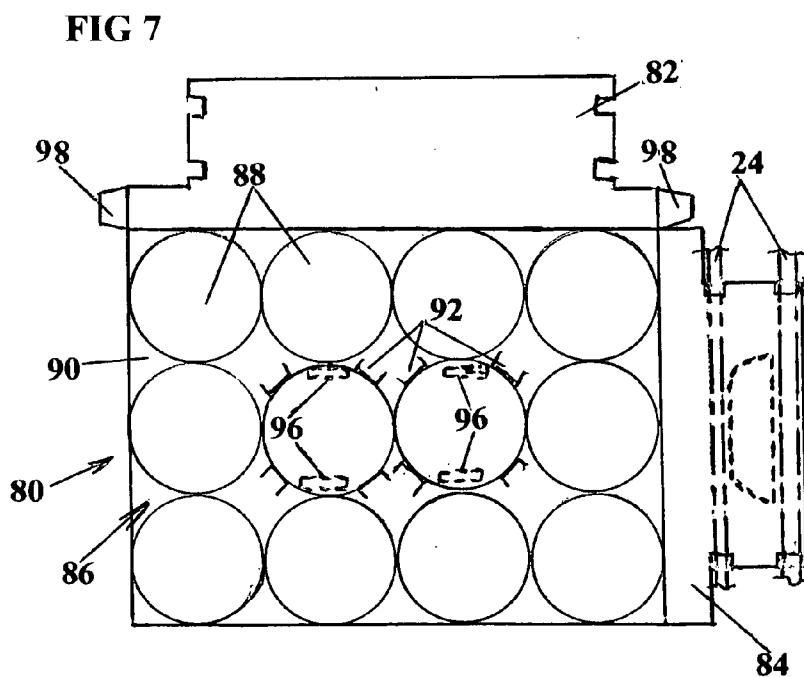
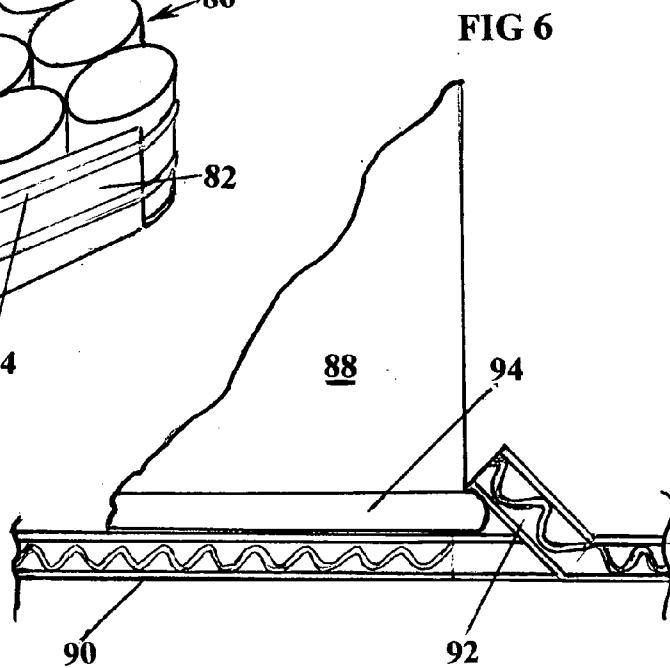
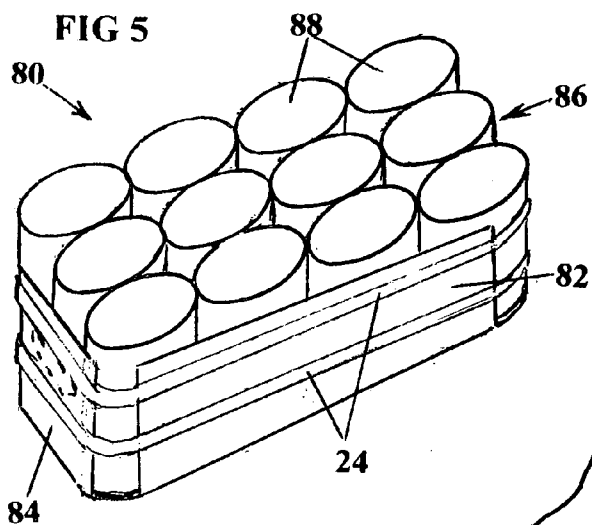

FIG 4





MULTISTRAP CONTAINER PACKAGE SYSTEM

CROSS REFERENCE TO RELATED APPLICATIONS

[0001] Not Applicable

STATEMENT REGARDING FEDERALLY SPONSORED RESEARCH OR DEVELOPMENT

[0002] Not Applicable

REFERENCE TO MICROFICHE APPENDIX

[0003] Not Applicable

BACKGROUND OF THE INVENTION

[0004] This invention is directed to transit packaging of reduced content, for use in shipping walled containers of glass, aluminum, steel, plastic or other materials, being shipped as a multi-pack format, and incorporating the use of multiple strapping

[0005] Presently, Glass container manufacturing is a 365 day/24 hour continuous operation that provides glass containers for many customers in the Food and Beverage Industry.

[0006] There are two basic formats that the glass industry uses to prepare empty ware for shipment to the market place. Bulk palletizing is the primary method of shipping glass to large volume customers possessing automatic de-palletizing capabilities. Customers receiving glass in this fashion are usually large volume producers capable of packaging in whatever format that suits the retailers and the consumer markets.

[0007] For lower volume users, glass containers from the glass manufacturer are packed in full or half partitioned corrugated cartons. The medium volume users receiving glass containers in this fashion have no alternative form of transit packaging, to reduce their packaging costs.

[0008] Such cartons often do not entirely suit the retailer's needs, such that the retailer must re-conform each case for display of the products on shelves or in pallet displays, usually by cutting off portions of the case or carton.

[0009] Containers of glass, aluminum, steel, plastic and other materials, with contents such as, oil, soap, industrial and domestic chemicals, vegetables, juices, tinned soups and soft drinks are generally packaged as a multi-pack format, for effective palletizing, shipping and retail display. This type of packaging frequently requires the use of additional support when being palletized.

[0010] The prior use of full corrugated boxes or shrink wrapped units is excessively wasteful of cardboard, while shrink wrap is also uneconomic. In ongoing attempts to reduce total packaging content two U.S. states have enacted laws requiring 10% packaging reductions.

[0011] The use of trays on which the containers are nested and then shrink wrapped reduces the packaging material but creates other problems regarding structural integrity, while the capability to display goods in palletized format without re-handling of the trays, is lost.

[0012] Shrink wrapped trays lack horizontal or lateral stability on pallets when shipped.

[0013] Consequently, pallet loads are prone to high rates of damage during shipping. Also, shrink wrapping is characterized by extensive energy requirements to shrink the wrap, most of which energy is lost as heat to the atmosphere.

[0014] Examples of packaging that address structural problems by use of dividers or stackers elements to improve the stability of packages are found in U.S. Pat. Nos. 3,826,357 and 4,998,615. Such use militates against any significant reduction in packaging materials.

[0015] Canadian Patent No. 1,191,819 describes a multi-package assembly, wherein the packages are sandwiched between sheets of cardboard and secured by strips of fragile adhesive tape. While this reduces the packaging, it does not provide adequate lateral strength to prevent sideways shifting of packages off a loaded pallet.

[0016] Other attempts to reduce packaging, by the use of a polyethylene strap have shown that circular rigid and semi-rigid containers when so strapped in conventional pack patterns are not stable, and have failed in transportation.

[0017] These packages are subject to twisting, so that the contact points between containers are changed, with undesirable nesting, destroying the integrity of the assembly. In one-strap multipack assemblies the centre containers are insufficiently secured and can slide out of the pack. This problem is prevalent in multi-packs with 12, 24, and 48 containers arranged in 3 or more rows.

[0018] Such prior art container assemblies are subject to dynamic forces during transportation, which can cause containers to shift and can cause individual plastic containers, such as carbonated beverages to deform. Such shifting and deformation in a multipack can damage individual containers, while compromising the structural integrity of the pallet load, ultimately resulting in safety and other problems.

[0019] The use of a U-shaped support envelope and a strap, shown in U.S. Pat. Nos. 4,930,633 and 5,549,202, are attempted solutions. While this system results in reduced packaging, its use does run counter to the reduction in packaging, while the larger planform of the package limits close packing intervals, resulting in reduced space utilization. Also, in multi-row packages, central contents are prone to move.

[0020] This prior packaging is unsuitable for pallet displays, contrary to a major trend in retailing in the marketing of packaged goods from so-called "warehouse outlets", where it is desirable to move product directly from the transit vehicle to a retail display area, without requiring the unpacking of containers, or their removal from off the pallets.

[0021] To render the product visible and readily accessibly to consumers these prior art packages require unpacking and handling of the goods from their transit packages. The necessity of removing the packaging to access the product also hinders inventory tracking through bar code readers or other means.

[0022] A further disadvantage in the prior art is the limitations in glass-to-glass applications, where it is very difficult to multipack for a number of reasons. Cold glass is typically coated with a spray such as polyethylene for lubricity. Glass containers often are designed with minimal contact (heel and shoulder) areas which make them unstable

when tightly assembled. Accordingly, for purposes of stability such packaging often requires the uneconomical provision of corrugated cardboard separators between glass containers.

BRIEF SUMMARY OF THE INVENTION

[0023] The present invention provides a multistrap transit packaging with at least one chime lock, and a plurality of package-securing straps.

[0024] This reduces packaging material content, while providing structural integrity during transit, and stable pallet loads.

[0025] It will be understood that interlock between adjacent containers can be provided for restraining the base of containers without necessitating the use of chimes for a base or bases.

[0026] The subject packaging of the present invention also provides for improved assembly of such containers in a compactly packed fashion.

[0027] The use of a glued construction adds stability to the overall structure. In the case of multi-pack packages in accordance with the present invention, central chime locks restrict movement of the centre row of containers, while the incorporation of dual straps restrict movement of the perimeter containers. Furthermore, the provision of a second strap with semi-rigid container assemblies has been found to be extremely beneficial in countering those dynamic forces that act upon containers while in transit.

[0028] The addition of the second strap around the assembly adds significant stability and integrity to the multipack. Both straps are applied with similar tension.

[0029] The plastic strapping used is high tensile polyethylene, with low elongation characteristics. The arrangement serves to stabilize the containers in a rigid even plane with each of the straps serving to maintain rigidity and limit or prevent twisting of individual containers that could otherwise dislodge them from making contact with adjoining like containers at their respective limited contact areas.

[0030] The second strap also serves as a safety feature, having the capability to maintain the package structure intact in the event that the other strap breaks.

[0031] The subject packaging of the present invention provides a reusable tray with glued corners, that can be used initially by glass manufacturers to ship glass containers in the unstrapped tray, as part of a bulk, palletized shipment to a goods producer, who can unload the glass containers from the tray, fill them with their produce, and re-pack the filled containers into the re-usable tray, and apply two straps, to effectively complete the packaging. The side and end flaps of the packaging have strap-recesses in their vertical (end) edges, to receive and locate the two straps in predetermined, mutually spaced relation.

[0032] In initially shipping the empty glass containers, the multi-tier pallet-load of containers-in-trays is capped with a cardboard enclosure cap having glued corners, which is secured in place to the pallet with two or more vertical straps, thereby securing the load of trays to the pallet.

[0033] The second-transfer operation of the subject packages, each with its containers filled, includes each package

being wrapped with a pair of straps, followed by palletizing and shipment to stores, where a package forms a pallet-ready display, to the great convenience of the store merchandiser.

[0034] In the case of goods manufacturers of modest volume production, as distinct from those manufacturers whose large turn-over volume enables them to receive their glass containers in large bulk palletized containers, the subject container system, by the provision of reusable trays that can be used in a first mode to transport empty glass containers from the glass supplier, which trays are then re-used, in a second mode, for transporting the filled containers to the retailer, this dual usage reduces their material costs, to significantly improve their competitive position.

[0035] Also, of course, by re-use of the subject package in this manner, material wastage is greatly reduced.

[0036] Another embodiment of the subject package may provide paperboard transit packaging having a paperboard sheet that extends at least partially about a plurality of like containers. The paperboard blank has side panels foldable to extend substantially perpendicular to the blank central portion, at least one chime lock located in the central portion of the blank, to receive an end of a container therein, and at least two straps for securely wrapping the blank about the assembled containers. The straps bind the paperboard sheet and the containers together, forming a structural package. The use of at least two straps minimizes the effects of dynamic forces occurring during transit, while the chime lock/locks serve to minimize movement of the central containers on the blank.

[0037] In another multi-strap embodiment having a corrugated cardboard base with vertical sides of reduced vertical dimension, in the case of a multi-row package, central ones of the packaged containers, which have no contact with the package wall or the multiple straps, are stabilized by way of foot chimes, which may engage locally enlarged base portions of the respective containers. These restraints may be supplemented or even replaced by the use of localized spots of frangible adhesive connecting the base of the respective central containers to the cardboard base. This offsets the tendency of such central, unrestrained containers to 'climb' out of the package, while making their ultimate removal comparatively easy.

[0038] The end flaps of the package may have a push-out handle flap portion scored into the cardboard, preferably being located below the top strap, such that the flap portion covers over the adjacent strap when the flap is displaced outwardly and upwardly to open the handle aperture.

[0039] One subject packaging leaves the ends of the package substantially open, with a further advantage of leaving the labels of the product exposed, which is beneficial for pallet displaying and convenient for bar code reader access and/or inventory tracking.

[0040] One embodiment of the present invention provides the potential of a glueless package, wherein the overlapped ends of the package are secured by way of a strap. In the case of a two-strap package, the glueless joint may be located beneath the top or the bottom strap.

[0041] In a preferred embodiment, the mutually overlapped slotted edge portions of the package which serve to locate the strap, are enlarged and retained to serve as safety

tabs, being trapped in mutually sandwiched relation between the strap and the adjoining wrapped surface of the container. This arrangement permits the generation of high frictional forces between the overlapped ends of the package, using the tension of the strap to generate that friction.

[0042] Using a releasable self-adherent strap, the release of the strap automatically releases the non-glued package joint, thereby opening the package to provide full access to the containers therein. In the case of a package having two such non-glued or "dry" joints secured by the same band, the unpeeling or severing of the band then opens the package, to permit removal of the top (cover) portion of the package.

[0043] In a multi-pac corrugated cardboard package engineered to accommodate top loads, such as being stacked in pallets, where the weight of each loaded pallet is in the order of 1900 to 2,000 pound, by selecting a corrugated board having edge test compression strength per foot of edge length in the range 125 to 250 lbs per foot, the required strength can be achieved. It will be understood that the board corrugations are vertically oriented.

[0044] The integrated package performance of a sleeve-packaged multi-pac under crushing loads includes the vertical load contribution of the corrugated sleeve side walls, combined with the vertical wall strength of the filled containers. The lateral stability of the total package is integrated by the engagement of at least some central ones of the containers with chimed apertures in the package cover portion, which engagement stabilizes the package against sway-loads.

[0045] Thus, the pallet load capacity of a selected container/package combination can be selectively engineered, by appropriate selection of the load capacity of the corrugated board walls, to provide a two-high or a three-high pallet stack of filled containers

[0046] The present invention thus provides a method of packaging a plurality of like containers using a cardboard blank. The blank has opposed side panels foldable to extend substantially parallel to each other and each side panel has notches at opposite sides such that when the panels are folded the notches are horizontally aligned. The containers each have straight side portions, a top and a bottom.

[0047] The method comprises the steps of placing a pre-determined number of like containers onto the blank in a regular pattern in side by side relation between the side panels, wherein one or more containers located centrally on the blank are retained by means of one or more chime locks of the blank, positioning at least two straps in the notches and securing the strap about the blank to form a structural package.

[0048] The ends of the cardboard blank may be overlapped, and adherently secured, by gluing, taping and the like. Conversely, as described above, a dry joint or joints may be secured by one of the bands. Certain embodiments may utilize paperboard blanks, others may use corrugated cardboard, or at least a corrugated cardboard base

[0049] One paperboard embodiment may have two glued joints, located high up, one along each side of the package, to provide a high-strength, load bearing zone, to facilitate transfer. Hand-holds may adjoin the overlap glue zones.

[0050] In a non-glued embodiment, a removable package 'cap' may be provided, secured by the top strap, as explained above.

[0051] The foregoing invention results in a transit packaging having reduced materials content, exceptional structural integrity, and is suitable for contents-display purposes without being dismantled from their pallets, by virtue of substantially open, end-access display areas, or suitably printable side areas of the packaging

BRIEF DESCRIPTION OF THE SEVERAL VIEWS OF THE DRAWINGS

[0052] Certain embodiments of the invention are described by way of illustration, without limitation thereto other than as set forth in the accompanying claims, reference being made to the accompanying drawings, wherein:

[0053] **FIG. 1** is a side/end perspective view of a two-container package embodiment according to the present invention;

[0054] **FIG. 2** is a similar perspective view of a multi-container package embodiment;

[0055] **FIG. 3** is a view similar to **FIG. 1** of a two-container package with a non-glued joint;

[0056] **FIG. 4** is a view similar to **FIG. 1** of a two-container package having two glued joints;

[0057] **FIG. 5** is a perspective view of a twelve-pack package embodiment;

[0058] **FIG. 6** is a plan view of an embodiment having two sides unfolded, and

[0059] **FIG. 7** is a scrap sectional view showing a chime arrangement portion of **FIG. 6**.

DETAILED DESCRIPTION OF THE INVENTION

[0060] It will be understood by one skilled in the art that the accompanying illustrations and the following description are but illustrative of the present invention, and are subject to modification by one skilled in the art, within the scope of the following claims.

[0061] Referring to **FIG. 1**, a package **10** in accordance with the present invention has a paperboard wrap **12**, the ends **14**, **16** of which are overlapped and adhered to each other to form joint **17**, by gluing, taping or the like.

[0062] The side panels **18**, **20** have slots **22** at their edges, by which straps **24**, **24** are located. The top panel **26** of wrap **12** has a pair of apertures **28**, each aperture **28** being bounded by chime locks **30**. The bottom panel **32** is usually left plain.

[0063] A pair of containers **34** each has a removable cap portion **36** that the chime locks **30** engage, when the wrap **12** is applied, and the joint **17** is completed.

[0064] The straps **24**, **24** are located in the slots **22**, so as to wrap the ends of the containers **34**, being then tensioned and secured, as referred to above.

[0065] In the **FIG. 2** embodiment the package **40** contains three rows of containers **42**, which are substantially cylindrical, i.e. straight-sided. All of the containers **42** are illus-

trated as having chime locks 30. However, it will be understood that chime locks 30 may be selectively applied, such that for instance only the central row of containers may be so locked, or the four "corner" containers may be provided with chime locks 30. Alternatively, only the outer two containers of the centre row might be chime locked, to effect adequate locking for transportation needs, with minimized obstruction for removal of the package cover portion.

[0066] Turning to FIG. 3, a package 50 has a "dry" (non-glued) joint 57, where one end 54 of the wrap overlies the other end 56 of the wrap. The top set of four slots 23, which perforate both ends 54, 56 of the package wrap, are illustrated as having enlarged outer ends, with the tab portions 25 being unsevered. These eight tab portions 25 are trapped by the top strap 24 against the outer surfaces of the adjoining containers 34, and serve to frictionally lock the ends of the joint 57. Severance of the top strap 24 frees the joint 57, to expose the top of the containers 34.

[0067] It will be understood that two such non-glued joints may be provided to form a removable top portion for the package 50.

[0068] Turning to FIG. 4, a package 60 has a paperboard wrap 62 having a separate upper, cover portion 64.

[0069] The upper ends of the side panels 66, 68 are shown inserted in glued relation inside the cover portion 64. This arrangement provides a double-thickness upper portion to the package 60, which serves to reinforce the hand-hold pull-out 70. The side panels 66, 68 may also be glued to the outside of the cover portion 64.

[0070] Turning to FIGS. 5, 6 and 7, a 12-pack package 80 has two side flaps 82 and end flaps 84. Corner flaps 98 are glued to the end flaps 84, to form the initial-use shipping tray.

[0071] A pair of straps 24 secure the sides 82, 84 in securing relation with the re-packaged contents 86. The two side flaps 82 and end flaps 84 have two strap-recesses on each of their end edges, to accurately locate the straps 24, when such are installed in a two stage, re-use operation, as described above.

[0072] The illustrated contents 86 are portrayed as cans 88, such as beverage cans.

[0073] The corrugated cardboard base 90 is scored in the central zone to provide a plurality of chimes 92 for the two central cans 88, 88. The chimes 92 engage rib portions 94 of the cans 88 (see FIG. 6).

[0074] To further assist the chimes 92 in retaining the two central cans 88, localized deposits of frangible thermoplastic adhesive 96 are particularly located on the base 90, to be engaged by the bottoms of the two central cans 88 (see FIG. 7). Pressure sensitive adhesive may also be used for this purpose.

[0075] In use, upon release or severance of the straps 24, the frangible adhesive patches 96 fracture under the application of withdrawal forces, releasing either of the two central cans 88, for removal from the package 80.

[0076] The end flaps 84 of the package 80 have a push-out handle flap portion (shown in dashed lines) scored into the cardboard, shown as being located below the top strap 24, such that the flap portion covers over the top strap 24 when

the handle flap is displaced outwardly and upwardly to thereby open the handle aperture.

[0077] Two-phase use of the packaging is discussed above, wherein the package 80 is used initially to transport empty containers (usually glass), without utilization of the pair of straps 24. In the second phase, of package re-use, the filled containers are packed into the package, being made fast by the application of a pair of straps 24, and shipped to the retailer.

1. A transit packaging for use with a plurality of like, substantially straight-sided containers, said packaging comprising a cardboard blank having a central portion, side panels foldable to extend substantially perpendicular to said central portion, at least one chime lock located in said central portion, to engage an end of a said container therein, the ends of said blank being secured together to form an enclosure, for containing said plurality of containers in mutually assembled relation therein, and at least two laterally extending straps for securely wrapping the blank about the assembled containers to form a structural package.

2. A transit packaging for packaging a plurality of like containers of uniform height, shape and size, and having substantially straight sides, said transit packaging comprising: a blank of paperboard having score lines defining a top panel, foldable opposed side panels to extend substantially perpendicular to said top panel; said top panel having at least one aperture to receive a portion of a said container in entered relation therein; a plurality of mutually aligned slots in the side edges of said side panels, to receive at least two laterally extending straps in mutually spaced parallel relation; at least two straps located in said aligned slots and wrapped about said side panels and enclosing said containers to retain said side panels in said perpendicular condition, forming a structural package.

3. The packaging as set forth in claim 1, said side panels each having slots in the edges thereof to receive said straps in entered, positioned relation therein.

4. The transit package as set forth in claim 1, wherein at least a base portion of said package is of corrugated cardboard, said base portion including container location means selected from the group consisting of said at least one chime lock and localized portions of frangible glue adhered to said base portion, and combinations thereof, for locating a said container in removably secured relation with said base.

5. The transit package as set forth in claim 4, wherein said package is a multipack for a plurality of said containers arranged having two outer columns, each adjoining a said side panel and at least one inner column remote from said side panels, and having a said container of said inner column secured to said base portion by said container location means.

6. The packaging as set forth in claim 1, wherein said ends of said blank are secured by a glued joint.

7. The packaging as set forth in claim 1, wherein said ends of said blank are secured by a dry joint having tab portions of the blank secured in sandwiched relation against said containers by way of said straps in tensioned relation.

8. The packaging as set forth in claim 1, wherein said straps are hand-peelable.

9. The packaging as set forth in claim 6, wherein said blank central portion is secured to said side panels by way of two glued joints.

10. The packaging as set forth in claim 9, including at least one push-out handle portion located adjacent a said glued joint.

11. The packaging as set forth in claim 7, wherein said joint tab portions have enlarged ends to extend laterally from beneath said straps.

12. The packaging as set forth in claim 2, said side panels each having slots in the edges thereof to receive said straps in entered, positioned relation therein.

13. The packaging as set forth in claim 2, wherein said ends of said blank are secured by a glued joint.

14. The packaging as set forth in claim 2, wherein said ends of said blank are secured by a dry joint having tab portions thereof secured in sandwiched relation against said containers by way of said straps in tensioned relation.

15. The packaging as set forth in claim 2, wherein said straps are hand-peelable.

16. The packaging as set forth in claim 15, wherein said blank central portion is secured to said side panels by way of two glued joints.

17. The packaging as set forth in claim 16, including at least one push-out handle portion located adjacent a said glued joint.

18. The packaging as set forth in claim 14, wherein said joint tab portions have enlarged ends to extend laterally from beneath said straps.

19. The packaging as set forth in claim 1, wherein said paperboard enclosure is open-ended, to provide visual access to label portions of said containers.

20. Transit packaging as set forth in claim 1, containing at least three rows of said containers; the end containers of the outer rows of containers being wrapped about a portion of their circumference by said straps, in tensioned, containing relation therewith.

* * * * *