

- [54] APPARATUS FOR PRODUCING  
NON-WOVEN FLEECES
- [75] Inventors: **Mutsuo Matsuki**, Nobeoka; **Sadaji Nishimura**; **Masato Goto**, both of Fuji, all of Japan
- [73] Assignee: **Asahi Kasei Kogyo Kabushiki Kaisha**, Osaka, Japan
- [22] Filed: **Sept. 29, 1972**
- [21] Appl. No.: **293,694**

3,379,811	4/1968	Hartmann.....	425/72 X
3,436,792	4/1969	Hench.....	425/72
3,335,210	8/1967	Vinicki.....	425/72 UX
2,780,909	2/1957	Biefeld et al.....	57/164
3,460,731	8/1969	Troth.....	106/90 X
3,485,428	12/1969	Jackson.....	226/97
3,486,318	12/1969	Cannon et al.....	264/210 F X
3,497,586	2/1970	Hemker et al.....	264/210 F
3,509,009	4/1970	Hartmann.....	161/175 X

**Related U.S. Application Data**

- [63] Continuation of Ser. No. 77,086, Oct. 1, 1970, abandoned.

**Foreign Application Priority Data**

Oct. 1, 1969 Japan..... 44-78046

- [52] U.S. Cl. .... 425/66, 264/210 F, 425/72, 425/83
- [51] Int. Cl. .... **B29d 7/00**
- [58] Field of Search..... 57/164; 264/210 F, 177 F; 161/175; 425/66, 72, 83

**References Cited**

**UNITED STATES PATENTS**

- 3,528,129 9/1970 Hartmann..... 425/72 X

Primary Examiner—Robert L. Spicer, Jr.  
Attorney, Agent, or Firm—Sughrue, Rothwell, Mion, Zinn & Macpeak

[57] **ABSTRACT**

The invention relates to a process for the manufacture of a fleece-like sheet having a non-woven texture, from a large number of melt-spun monofilaments.

The improvement resides in the arrangement of the melt-spun monofilaments in a curtain-like form which is then subjected to the action of a pair of air jet streams in a sucker only once during travel of the curtain of monofilaments from the both sides thereof, the jet velocity of said jet streams being selected to be in the turbulent flow range, and then projected from the sucker onto a travelling gas pervious belt-like collector.

**4 Claims, 6 Drawing Figures**

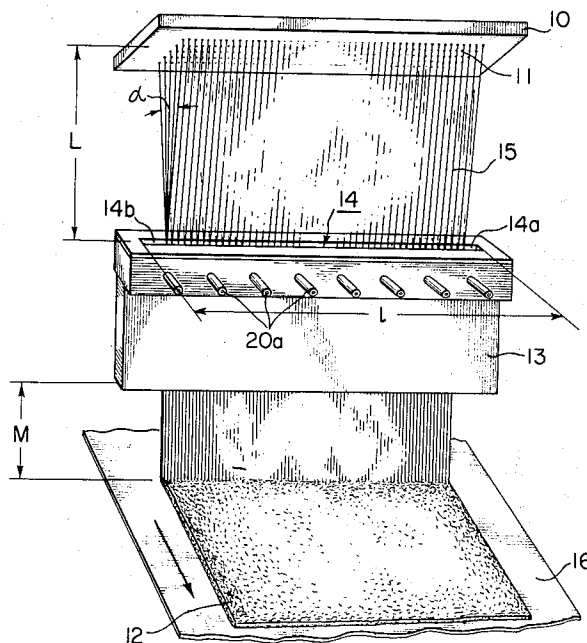

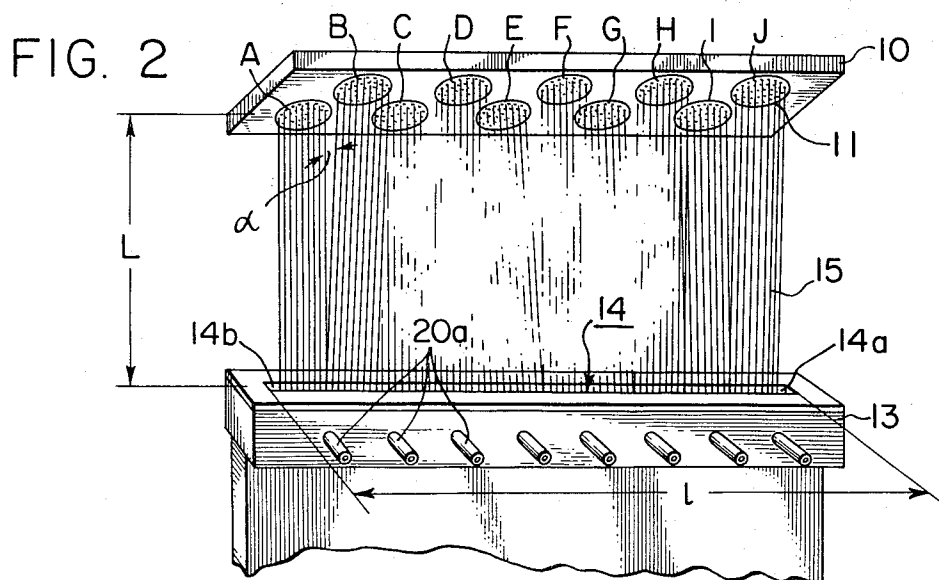
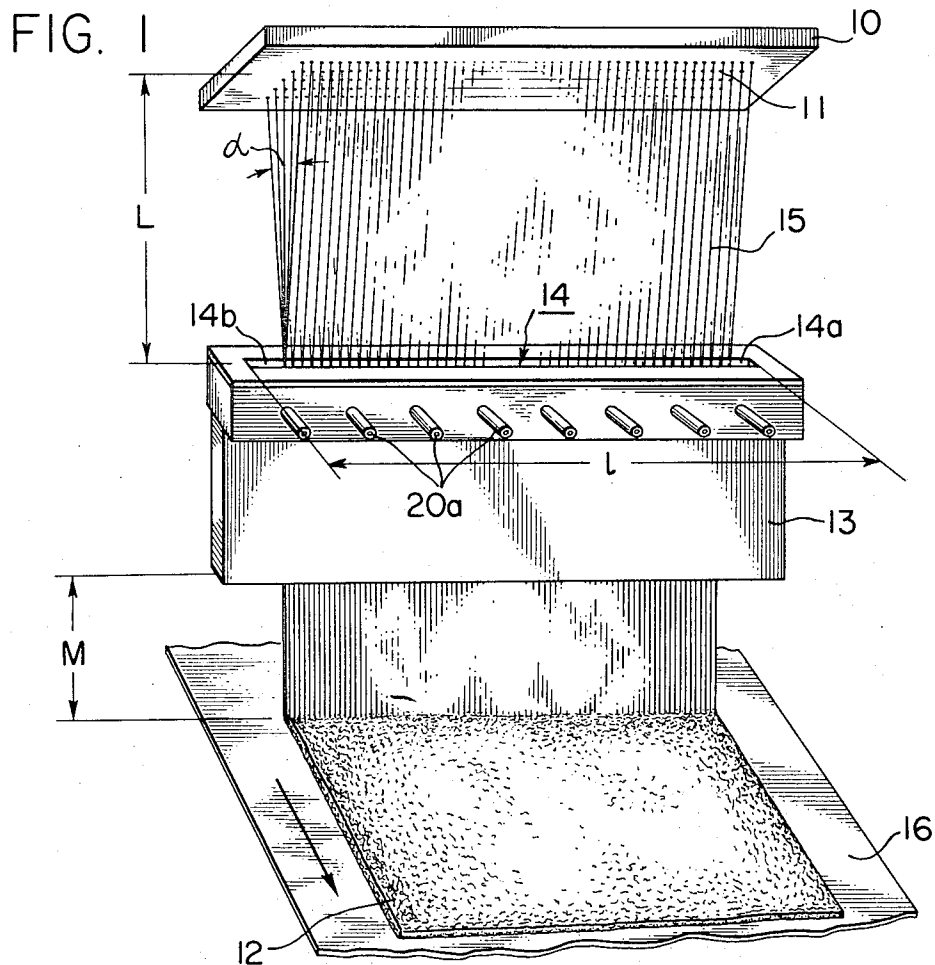

FIG. 3

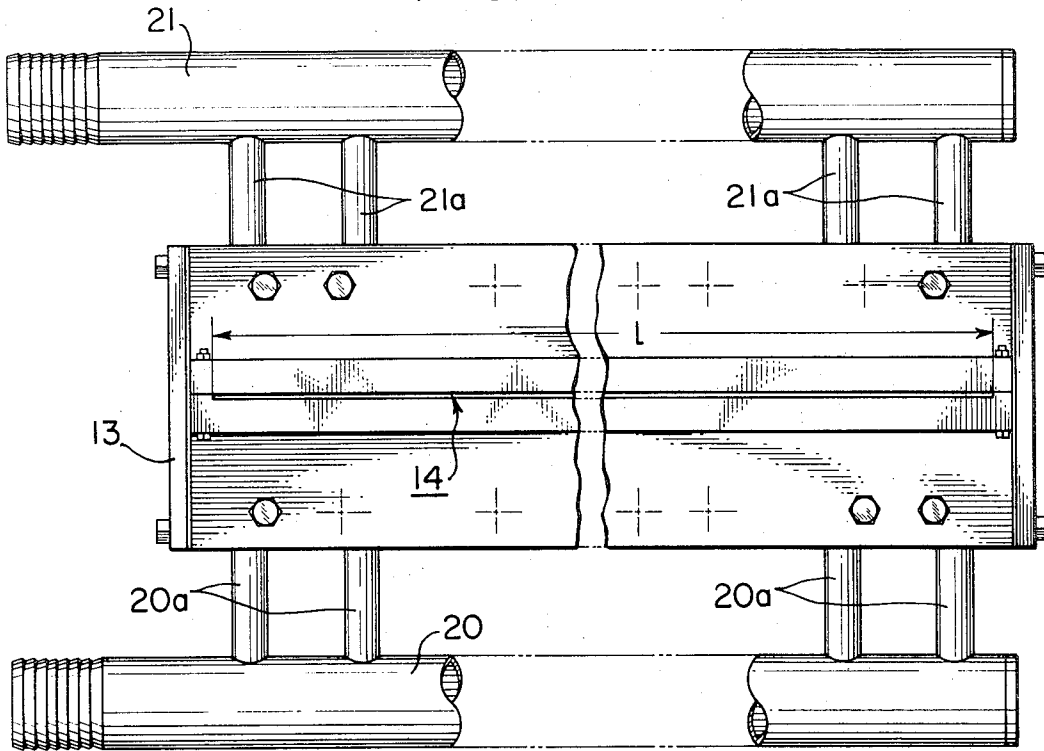
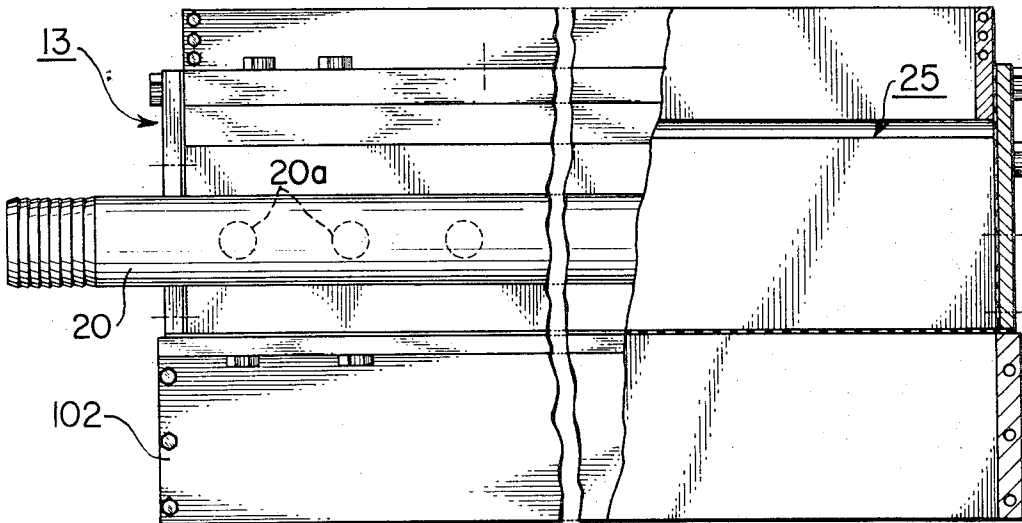

FIG. 4





## APPARATUS FOR PRODUCING NON-WOVEN FLEECES

### RELATED U.S. APPLICATION

This is a continuation, of application Ser. No. 77,086, filed Oct. 1, 1970, now abandoned.

This invention relates to a process for the manufacture of a fleece-like sheet having a non-woven fibrous texture from a large number of melt-spun monofilaments and an apparatus adapted for performing the said process.

It has been already known to try to form a non-woven fleece-like fibrous sheet by projecting a large number of melt-spun monofilaments by use of a pressurized gaseous fluid through a sucker upon a travelling endless belt or wire gauze conveyor constituting an elongated pervious collector.

A substantial difficulty will be encountered in the practice of the said process in that the monofilaments become entangled when they are projected from the outlet of the sucker at a high speed upon the travelling collector. In order to avoid such a conventional drawback, it has already been proposed to separate a group of a large number of monofilaments at a certain later stage into its completely separated constituents by the utilization of strong repulsive forces developed by application of a static high voltage to the filament group. Such prior proposal, when adopted, leads, however, to a highly complicated structure of the apparatus used for the manufacturing purpose, in addition to the invitation of possible and dangerous hazards to the personnel who are engaging in the manufacture of the desired fibrous non-woven fleece products. According to our practical experiments, however, it has been ascertained that with use of a nozzle adapted for the above purpose and having a circular cross section, a larger and substantially circular distribution of the monofilaments, yet having a locally variable density is obtained. When a nozzle of rectangular cross section is used, an elongated elliptical fiber distribution is produced, which represents, however, a considerably uneven density distribution when seen in the direction along the longer axis of the elongated ellipse. Even with best efforts, however, it is impossible to manufacture continuously a band or sheet of non-woven fibrous structure having a certain and well-defined width and even density.

It is positively believed that any person skilled in the art has deemed that the jetting gaseous fluid must be kept in the laminar state if possible during passage thereof through the sucker nozzle, in order to avoid the formation of entangles in passing monofilaments through the sucker, should there be no powerful and fiber-separating assisting auxiliary means such as the application of high static voltage.

When such laminar flow of the gaseous injecting medium is employed, it is apparent that substantially no stretching action is applied to the monofilaments as extruded and being injected. According to a prior proposal, therefore, a high temperature and high pressure steam is injected at a close proximity to the extrusion spinneret and upon the monofilaments as extruded, so as to speed up the filament delivery velocity for performing the desired stretching thereof, the steam injecting means adopted for this purpose being arranged around the spinneret. However, such application of high temperature, high pressure and high velocity

steam jet streams upon the monofilaments as extruded has invited frequent breakage of the monofilaments and thus, it is believed that such prior proposed arrangement can not be employed in the practical manufacturing plants. In addition thereto, it is further believed that such application of high temperature and high speed steam jet streams upon the extruded monofilaments will substantially defer the cooling and solidification of the extruded material, leading to substantially unfavorable results. Consumption of a large amount of high temperature, high pressure steam naturally invites a substantial amount of addition manufacturing as well as investment costs to the plant. Operation and labor costs will naturally be increased correspondingly which leads to unfavorable results against the adoption of such proposed manufacturing plant.

It should be noted that when obeying such improving prior proposals, the nature and structural conditions of the desired non-woven fibrous products will become substantially inferior, especially when seen in their defining configuration and density demands for the well-refined band-like products having even thickness throughout the overall length and width of the products. These drawbacks would lead to inhibitingly disadvantageous drawbacks.

According to a further improving proposal, several stages of nozzles are provided in the sucker, so as to establish and maintain a nearly laminar flow of the sucking and injecting gaseous medium flowing through the sucker. However, according to the practical experiments carried by us, it has been ascertained that by employment of such multistage-nozzled sucker, the passing monofilaments therethrough become rather more entangled during passage thereof through the sucker. In addition thereto, additional substantial cost will be invited by the employment of such multistage nozzle system.

It should be further noted that the high speed fluid flow delivered from the sucker nozzle will affect the monofilaments delivered together with the gaseous fluid flow from the same nozzle, only in an indefinite way so that the numerous filaments are subjected to various degree of accelerating and other influences, especially when seen individually the filaments under treatment, resulting in a more entangled state of the filaments as a whole. Therefore, according to the prior art and prior proposals, it has been highly difficult to manufacture wide-width fibrous sheets of the kind and nature above referred to.

The main object of the invention is to provide a process and apparatus for the manufacture of continuous fibrous band or sheet of fleece-like non-woven structure belonging to the kind and nature above referred to and having a broad width amounting to 2 meters or more in a single treatment of a very numerous number of monofilaments melt-spun from a spinneret structure and a high operating efficiency and in an easy way.

The basic principle of the invention for the fulfilment of the aforementioned object of the invention resides in such that a large number of monofilaments are melt-spun from the corresponding number of extrusion orifices positioned in an elongated rectangular arrangement having its length substantially to cover the fibrous band or sheet to manufacture and into an open air atmosphere, and then introduced into a single-nozzle-stage sucker having a narrow slit-like passage opening formed vertically therethrough and positioned at a cer-

tain enough distance below said extrusion orifices to coagulate at least the surfaces of the extruded monofilaments, said monofilaments being introduced into and discharged from the sucker in the arrangement of a curtain and the latter being impinged only once from its both sides its width by a pair of jet air streams having such a high speed for establishing a turbulent state within said passage for subjecting the curtain-like arranged monofilaments to cold stretching and accelerated delivery and projected together with the combined air jet stream upon a travelling collector of a gas pervious nature.

According to the invention, the sucking gaseous medium should be one and the same medium throughout the processing of the curtain monofilaments within the sucker, the action of jet streams upon the curtain must be absolutely only one. Two or more applications at several places selected along the passage of the monofilaments invite considerable and disadvantageous entangling of the filament.

It will be easily understandable that the air jet streams acting upon the curtain monofilaments led through the slit passage formed through a sucker must have a predominant velocity component in the travelling direction of the filament, while the lateral velocity component must be considerably smaller than the former component. On the other hand, the air jet velocity must be as large as possible for the continuous monofilaments melt-spun, so as to improve rather favorably the molecular orientation of the filaments, and at the same time for accelerating the travelling velocity downstream of the jet unit to a corresponding degree, thereby improving correspondingly the manufacturing efficiency. Further, according to common sense among those skilled in the arts, the air flow downstream of the jet unit must be as laminar as possible along the filament passage through the sucker, in order to avoid invitation of agitation effect upon the travelling filament and at the same time for the prevention of formation of filaments entangling. Therefore, it has been a standard practice to try to satisfy these contradicting requirements to a satisfying degree. The invention is based upon a novel technical idea which is, indeed, in complete opposition to the said traditional concept owned by the technicians in the field of the textile industry. According to the novel teaching of the invention, jet streams can be safely applied to a curtain-of monofilaments only once within the interior of the sucker, even with a supersonic range of air jet streams, and indeed without fear an entangled ball formation in the manufactured non-woven fibrous products.

These and further objects, features and advantages of the invention will become more apparent when read the following detailed description of the invention by reference to the accompanying drawings and several preferred numerical examples of the invention.

In the drawings:

FIG. 1 is a perspective view of an apparatus for carrying out the process for the manufacture of fleece bands or sheets of non-woven nature, being based upon the novel teachings of the invention.

FIG. 2 is a modified apparatus from that shown in FIG. 1, illustrated in the similar way as before, but showing only essential parts of the apparatus.

FIG. 3 is an enlarged plan view of a sucker unit employed in the foregoing apparatus embodiment part

thereof being, however, omitted from the drawing for simplicity.

FIG. 4 is a side view of the sucker unit shown in FIG. 3, wherein, however, part thereof is shown in section.

FIG. 5 is an end view of the sucker unit shown in FIGS. 3 and 4, wherein several parts are shown in their section.

FIG. 6 is an enlarged axial sectional view of an air injection nozzle unit provided in the air sucker.

Now referring to the accompanying drawings, a preferred embodiment of the apparatus adapted for carrying out the manufacturing process according to this invention will be described in detail hereinbelow.

In FIG. 1, numeral 10 denotes a spinneret having a large number of extrusion orifices 11 which are arranged into an elongated rectangle, the length of which is selected to cover substantially the width of the non-woven fibrous sheet 12 of fleece-like structure to be manufactured, as will be described hereinafter.

Below the spinneret 10 and at an appreciable distance "L," there is provided a sucker unit 13 having a narrow and elongated slit 14 passing completely through the sucker, as is most clearly be seen from FIG. 5.

When the effective length of the slit 14 amounts to, for instance, 2 meters, it is recommendable to arrange the extrusion orifices 11 in five parallel rows having a mutual spacing of 4 millimeters as an example, in the present specific embodiment, there are provided 2,500 orifices 11 as a whole.

When it is desired to use monofilaments, for instance, 0.3-20 denier per filament, the said distance "L" amounts to about 50-200 centimeters.

From the extrusion orifices 11, a high polymer fused and consisting of, for instance, nylon 6 or -66, polyethylene terephthalate, is extruded in the state of the corresponding number of continuous monofilaments 15. Within the range of said distance "L," the extruded filaments travel through an open air atmosphere, preferably having normal temperature. However, under conditions, the filaments travel zone may be confined by a certain cover means for modifying the ambient atmosphere to unelevated temperature, or so as to introduce therein cooled ambient air. Under certain operating conditions, the travelling filaments can be cooled by being impinged upon by cooled air streams. Anyhow, said travel region "L" is adapted for cooling the extruded and travelling monofilaments 15. As was referred to above, the extruded monofilaments 15 are introduced in the slit-like passage opening 14 in the form of a curtain. It is recommendable to provide small idle end zones 14a and 14b at the both extremities of the slit opening 14, so as to avoid the end effect, each of these idle zones amounting preferably to 20 millimeters in its length. As was referred to, the length "L" is so selected that the extruded continuous monofilaments 15 can be solidified at least at their surfaces and to lower their temperature to the solidifying point of the filament material. It is further preferable to provide 2-3 times cold stretch to the travelling monofilaments during the passage thereof through the cooling and stretching zone "L."

The included angle "alpha" as determined by the gradually approaching monofilaments as they form the curtain directly before entrance into the slit opening 14, as shown in FIG. 1, may preferably be selected to

less than  $15^\circ$ . The slit opening 14 must have a length so as to cover the width, 2 meters in the present specific embodiment, of the fleece band or sheet 12, while the width of the slit may preferably be 1–5 mm in this case, although it is variable with the denier per filament of the monofilaments and the required density of the fleece-like products 12.

The spinning speed of the melt-spun monofilaments 15 is generally selected to 3,000–6,000 meters per minute.

A modified manufacturing arrangement from that shown in FIG. 1 is shown only partially in FIG. 2. In this modification, the extrusion orifices 11 are grouped into small round or elliptic groups "A," "B", . . . "J," these groups being arranged in zigzag-shaped two rows in the lateral direction of the travelling pervious collector 16. The included angle "alpha" of the extruded monofilaments 15 may amount equally to the above specified values. Other structure is same as before so that the corresponding constituents have been denoted with the respective same references as above.

Turning again back to FIG. 1. When the above filament travel length through the air "L" is shorter than the above specified values, the extruded monofilaments 15 will contact with solid constituent of the sucker 13 in advance of solidification of the filament, resulting in development of the filament breakage or damage. On the contrary, when the length "L" is too long, a considerable amount of cold stretching air jet streams for the travelling filament through the sucker 13 will be necessary to consume which result in a higher operating cost. For this reason, it is preferable that the distance "L" must be selected to the above specified range necessary for solidifying at least the surfaces of filaments 15 upon passage of the through the air zone.

In order to identify the surface solidification of the extruded monofilaments 15 passing through the air, it only suffices to observe the surface appearance of the filament. If the filaments are not yet surface-solidified, these filaments are seen as considerably transparent, while if the necessary solidification has been attained, the surface appearance will be rather dull.

In the following, the structure and function of the sucker unit 13 will be described in detail by reference to FIGS. 3 – 6.

In these figures, numerals 20 and 21 represent compressed air pipings which are pneumatically connected to a certain compressed air source such as a reservoir provided for the purpose or air compressor, although not shown. From these air pipings 20 and 21 extend a plurality of parallel branch pipes 20a and 21a, respectively. These branch pipes are connected to respective distribution chambers 13 arranged in the interior space of the air sucker and at the both sides of the slit-like passage 14. It is recommendable to maintain the air pressure prevailing in the main air pressure distribution chambers 22 at 3–5 Kg/cm<sup>2</sup>G.

The main air chambers 22 are pneumatically connected through a plurality of axially arranged communication passages 23 running axially of the sucker to separated auxiliary distribution chambers 24a and 24b, respectively, to a jet nozzle unit 25. As seen from FIG. 5, the jet nozzle unit 25, the detail structure being shown in FIG. 6, is arranged at an intermediate point of the slit passage 14. Auxiliary air distribution chambers 24a and 24b have a length covering the whole length of the slit passage 14, the cross sectional area of

these chambers 24a and 24b is an elongated rectangle. By reference to FIG. 6, the jet nozzle unit 25 will be described in detail hereinbelow.

This unit 25 comprises a male component 26 and a female component 27 arranged axially of the slit passage 14 and in a partially overlapped manner, and the male component 26 is formed with a vertically and centrally arranged slit passage 28 which is an extension of the upper part of said slit passage 14 of the sucker unit 13. The width of this slit passage 28 is selected to the same size of the main slit passage 14, the former being an extension of the latter. The part of the monofilaments curtain passing through the auxiliary passage 28 is denoted by the same reference numeral 15 attached with a suffix "a."

At both sides, when seen in FIG. 6, of the lower end of the male component 26, there are formed a pair of nozzle openings 100 and 101, each having a considerable length as measured in the perpendicular direction to the drawing paper of FIG. 6 and amounting to the horizontal or lateral length "1" of the slit passage 14 when seen in FIGS. 1, 2 and 3 in the horizontal direction. The inlet width "x" of each of these nozzle openings amounts, as an example, to 0.6 millimeter and the outlet width "y" to 0.1 millimeter, respectively, while the height "h" as measured parallel to the vertical and central axis of the sucker unit 13, when seen in FIG. 6, said coinciding with the through-passing multifilament part 15a, amounts, by way of example in the present specific embodiment, to 4 millimeters. The inclination angle "beta" of each of the tapered inlet walls 100a and 100b formed on the female component 27 amounts to  $30^\circ$ .

It should be stressed at this stage that the lowest end 26a of the male component 26 has a strong tendency of reducing the size of the slit passage 15a under the action of compressed air pressure prevailing in the auxiliary chambers 24a and 24b and acting upon the lower end portion of the male component from both sides. At the outlet opening of said passage 15a when seen horizontally thereof, the opening area could be subjected to a bending deflection in the cross-section reducing sense, when the length of the sucker inlet or the width of the non-woven fibrous sheet 12 amounts to 2 meters or more, as is the case of the present embodiment. This tendency will invite naturally a corresponding enlargement of the nozzle outlet opening at "y" which enlargement is, however, variable along the width of the slit passage 14 or 28 by virtue of the aforementioned bending deflection. When such phenomenon should occur to an appreciable degree, the effect will be such that the nozzle effect exerted upon the travelling monofilaments curtain is variable and uneven when seen along the width thereof, resulting in substantial entangling of the curtain-like arranged monofilaments and thus in an appreciable variation of the density of the non-woven fibrous sheet 12. Therefore, the lower end of the male component must have a substantial rigidity over the whole horizontal length of the slit passage 28. For this purpose, the thickness "t" shown in FIG. 6 in the present specific embodiment amounts at least 2 millimeters, when the male component 26 has been made of common steel. With reduction of the horizontal length of the slit passage 14 or 28, the dimension of "t" may be correspondingly reduced, and vice versa. For this purpose, the designer may imagine a simple beam having a length equivalent to the horizontal

length of the slit passage 28 equal to said "l" and loaded with an even load distributed over its whole length, and calculate the maximum deflection expected to arise under these loading conditions. The monofilaments 15 melt-spun into the atmospheric air by extrusion of the spinneret 10 are introduced in the form of a curtain upon solidification at least of the surfaces of the filament, and then lead through the slit passage 28 of the male component 26 downwards. The filament curtain 15a will then be subjected to the air jets at the jet nozzle unit 25 by being acted upon by a pair of jet streams delivered at the both sides of the curtain from jet outlets 100a and 100b, during passage through the sucker 13. As seen from the foregoing, each of these jet streams is in the form of a plate when observed in their general outline. By the influence of these jet streams, ambient atmospheric air is sucked from outside of the sucker through slit opening 14 and slit passage 28 into the triangular space below the jet nozzles 101 and 102 and form a combined strongly downward flowing stream combined with jet streams delivered from the nozzle outlets 100a and 100b.

The flowing velocity of the jet streams from the outlet 100a and 100b from auxiliary chambers 24a and 24b is so selected that it lies in the range of turbulent flow, preferably in close proximity of the supersonic velocity range, in sharp contrast of the common sense of those skilled in the art. It is a rather astonishing fact that even with such high speed jet streams, the filament curtain is not encountered with disadvantageous entangles of the component filaments. The reason is believed to reside in such that by the arrangement of monofilament into a dense curtain-like arrangement, a cushioning effect is invited for the prevention of formation of the filaments entanglement. The jet streams have a substantial amount of a downward-directing velocity component, thereby the curtain-like filament being subjected to a considerable amount of downward acceleration. For this purpose, the injection nozzles 100 and 101 have each an inclination angle of to 15°-30°.

By the application of jet streams upon the filament curtain from the both sides thereof, as above-mentioned, the extruded filaments are fed downwards from the spinneret into the sucker at a high speed, and are subjected to a considerable degree of cold stretching in the passage range above the jet nozzle unit. Then, the filament curtain is fed through the slit passage 31 formed vertically in the female component 27, through the lower part of the passage 14 formed vertically through a depending attachment component 102 comprised in the sucker unit 13, and discharged from the lower end of the last mentioned lower part of the passage 14. The thus discharged filament curtain is then guided through the open air atmosphere along a predetermined distance "M" shown in FIG. 1 and impinged upon the travelling gas-pervious collector 16 shaped into an elongated endless belt, although not specifically shown.

The flowing speed of the combined down stream of the jet nozzle unit 25 must preferably be selected to about 2-3 times the spinning velocity, thus, in the present specific embodiment, 6,000-18,000 meters per minute. This air flow speed within the lower part of the slit passage for the filament curtain lies far into the turbulent flow range, but, according to the practical experiment, the employment such high air flow velocity will contribute rather favorably to the prevention of the

filament entanglement. This find is naturally contrary to the common sense prevailing among those skilled in the arts. The impinged and collected mass of the monofilaments constitute a continuous non-woven fibrous band or sheet 12 on the pervious collector 16 which sheet represents practically no filaments tangles and represents a substantially even density of the filaments and can be utilized satisfactorily as the material for the preparation of non-woven clothes. When these fibrous sheets are overlapped into a stark, a cotton-like mass may be obtained. The thickness of the fleece sheet can be controlled by the properly modifying the feeding speed of the collector 16.

In order to prevent possible disturbance in the formation of filaments upon the collector 16, it is preferable to keep the space below the collector at a negative pressure, although not specifically shown.

In following, several preferred numerical examples will be given for better understanding of the process according to this invention.

#### EXAMPLE 1

The width of the elongated slit passage 14 of the foregoing apparatus was selected to 2 millimeters; and the effective horizontal length of the same was designed to 2 meters, respectively.

The overall number of the extrusion orifices amounted 3,000 arranged 10 rows. Orifice opening was of 0.25 millimeter diameter, while the length "L" was set to 500 millimeters (with a length of less than 250 millimeters, frequent filament breakage was experienced).

The spinning material was nylon 6 which was extruded in the rate of 0.33' grams per minute per orifice by a spinning pump. The relative viscosity was 2.3 and the spinning temperature amounted to 260° C. The distance from the lower or discharge end of the sucker to the collector was set to 400 millimeters, the mesh of the collector being 40.

The overall vertical length of the sucker amounted to 31, the upstream length measured from the top end of the sucker and the discharge end of the air jet nozzle unit amounted to 10 centimeters and the downstream length of the sucker was designed to 21 centimeters.

Compressed air pressure prevailing in the main and auxiliary distribution chambers was 3 kilograms per centimeter, gauge; the jet outlet at each side of the filaments curtain was designed to 0.1 millimeter. The jet stream velocity amounted nearly to the supersonic one. The included angle "beta" was set to 30°, while that of the monofilaments "alpha" amounted to 3°.

Jet air was fed at a rate of 20 Nm<sup>3</sup>/min., when measured per meter of the horizontal length of the discharge outlet of the jet nozzle, when considering the amount per jet nozzle unit as a whole. The width of the slit passage 28 amounted to 2 millimeters, while that of the passage 31 was 2.1 millimeters.

Ambient atmospheric air was sucked into the sucker at a rate of 20-30 percent based upon the jet air.

Air flow velocity of 6,500 meters per minute was measured at the lowermost end of the sucker for a discharge speed of 3,000 meters per minute of the curtain filaments. Therefore, it will be seen that the air discharge speed amounts to 2-3 times the travelling speed of the curtain filaments at the lower stage of the overall processing travel.



(The air discharge speed can be increased to about 18,000 meters per minute. The horizontal length of the slit passage can be increased to about 4 meters at our present knowledge of the practical experience. The discharging and projecting speed of the curtain filaments can, in such case, be correspondingly increased).

The filaments curtain after stretching by application of jet streams from its both sides and by attaining of an air-rectifying effect by the curtain formation in the above sense could provide an ideal fleece-like sheet on the gas-pervious collector and without any fear of entanglement of the monofilaments. The length "M" was selected to 40 centimeters. Below the collector, a negative air pressure was maintained for avoiding formation of balled filament masses. The melt-spun filaments was of 1 denier per fil.

The thickness of the fleece sheet could be adjusted by modifying the travel speed of the collector. (By application of a conventional binder resin, the fleece sheet could be fabricated into a non-woven textile).

The thus produced fleece sheet represented practically no of filament tangles and showed a fibrous sheet-shaped mass consisting of an infinite number of irregular loops of filaments of an ideal condition as fleece.

When the distance "M" was increased to 70 centimeters, the produced fleece showed uneven density of filament, and had to be discarded on account of inferior structure incapable of being utilizing as the material for the production of non-woven textiles.

With an effective width of the collector set to 2 meters and employing the feed speed thereof to be 15 meters per minute, the quantity of filament contained in the fleece amounted to 33 grams per square meters.

EXAMPLE 2

In the foregoing example, the melt-spun filament was adjusted to 1.6 grams per orifice per minute, and with the height "L" of 600 millimeters and the width of air sucker slit was designed to 3 millimeters. The quantity of air jets was adjusted to 25 Nm<sup>3</sup>/min. and the air pressure in the distribution chambers was reduced to 2.5 kilograms per square centimeters, gauge. The air flow velocity down stream of the air jet unit was adjusted to 6,500 meters per minute for the travelling speed of filament curtain was selected to 2,900 meters per minute. The monofilament denier as measured at the sucker outlet amounted to 5. In this way, acceptable fleece sheet of equally favorable nature was obtained.

EXAMPLE 3

Polyethylen telephthalate, having an intrinsic viscosity of 0.6 was melt-spun in the similar manner as was described in the foregoing example 1, at a rate of 0.55 milligrams per orifice per minute and at 285° C. The fed compressed air amounted in its pressure to 3 kilograms per square centimeter and the feed rate of air jet was selected to 20 Nm<sup>3</sup>/min. The air flow velocity down

stream jet nozzle unit was 6,500 meters per minute, while the filament travel speed amounted to 3,300 meters per minute. Horizontal length of the sucker slit was 2 meters in length while the slit width amounted 2 millimeters. The number of extrusion orifices was 3,000, with orifice diameter of 0.25 millimeters. Under these conditions, acceptable fleece sheet of favorable nature was obtained. Denier per filament amounted to 1.5.

We claim:

1. An apparatus for the manufacture of a fleece-like non-woven fiber structure in the form of a sheet comprising an orifice plate having a plurality of extrusion orifices arranged generally in an elongated rectangular array having a longitudinal ring substantially equal to the width of the non-woven fibrous sheet to be manufactured through which an artificial high polymer material is melt-spun into a corresponding array of monofilaments, a sucker unit positioned below said orifice array at a sufficient distance to allow said monofilaments to solidify at least on the surfaces thereof and to allow said monofilaments to be stretched at least twice their length, said sucker unit comprising a first member having an elongated slot extending vertically therethrough for receiving said array of monofilaments in a substantially planar curtain and a second member having an elongated slot extending therethrough in vertical alignment with the slot in said first member, the slot in said second member having internal walls flaring outwardly adjacent the first member to define a V-shaped groove, said first member extending into said groove in closely spaced-apart relation to the walls of said groove to define an inlet passage means on each side of said first member, plenum chamber means disposed on opposite sides of said first and second members in communication with each of said inlet passage means and moving collector means disposed below said sucker unit for receiving said monofilament in the form of a fleece-like non-woven fibrous structure.

2. An apparatus as set forth in claim 1 wherein the angle of convergence between the orifices along the longitudinal edges of said array and the vertical plane in which said monofilaments are disposed during passage through said slots is between 10° and 15°.

3. An apparatus as set forth in claim 1 wherein said outwardly flaring walls of said slot in said second member are disposed at an angle of approximately 30° with respect to each other and the opposed walls of the portion of said first member extending into said slot are disposed at a lesser angle with respect to each other.

4. An apparatus as set forth in claim 1 wherein said first member is made of common steel and extends into said groove approximately one half the depth of said groove and is provided with walls on opposite sides of said slot each of which has a thickness relative to the length of said slot on the order of approximately 1 to 1,000.

\* \* \* \* \*