

(12) **UK Patent Application** (19) **GB** (11) **2468851** (13) **A**

(43) Date of A Publication

29.09.2010

(21) Application No: **0904878.6**
(22) Date of Filing: **23.03.2009**

(51) INT CL:
A63B 53/10 (2006.01) **A63B 53/02** (2006.01)

(71) Applicant(s):
Stewart Lee Manning
58 High Street, WHITTLEBURY, Northamptonshire,
NN12 8XJ, United Kingdom

(56) Documents Cited:
JP 2005270402 A1 **US 4253666 A**
US 3829092 A **US 20090075748 A1**
US 20070293340 A1

(72) Inventor(s):
Stewart Lee Manning

(58) Field of Search:
INT CL **A63B**
Other: **EPODOC WPI**

(74) Agent and/or Address for Service:
Albright Patents
Eagle Tower, Montpellier Drive, CHELTENHAM,
Gloucestershire, GL50 1TA, United Kingdom

(54) Title of the Invention: **Golf club**
Abstract Title: **Golf club**

(57) A golf club 10 comprises a collapsible shaft 12 and a removable head 14. The shaft is preferably telescopic and made from three tubular members 16, 18, 20, which are rotated relative to one another to facilitate movement and locking. The head 14 may be attached to the shaft 12 via a spigot comprising a non-circular element at the end of the shaft and a corresponding aperture in the head, the two being locked together via a releasable latch. A carry case or bag and more than one club head may be provided.

Figure 1

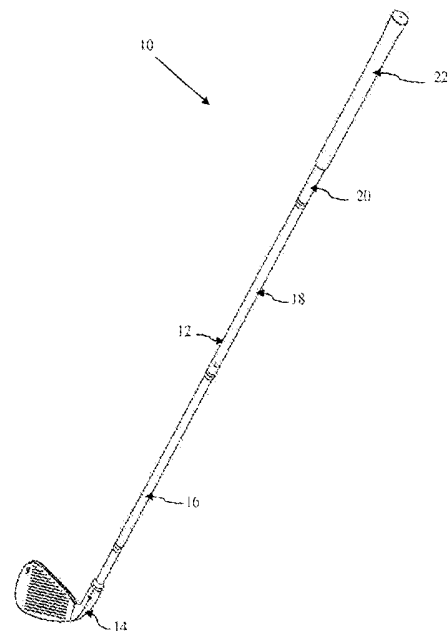

GB 2468851 A

Figure 1

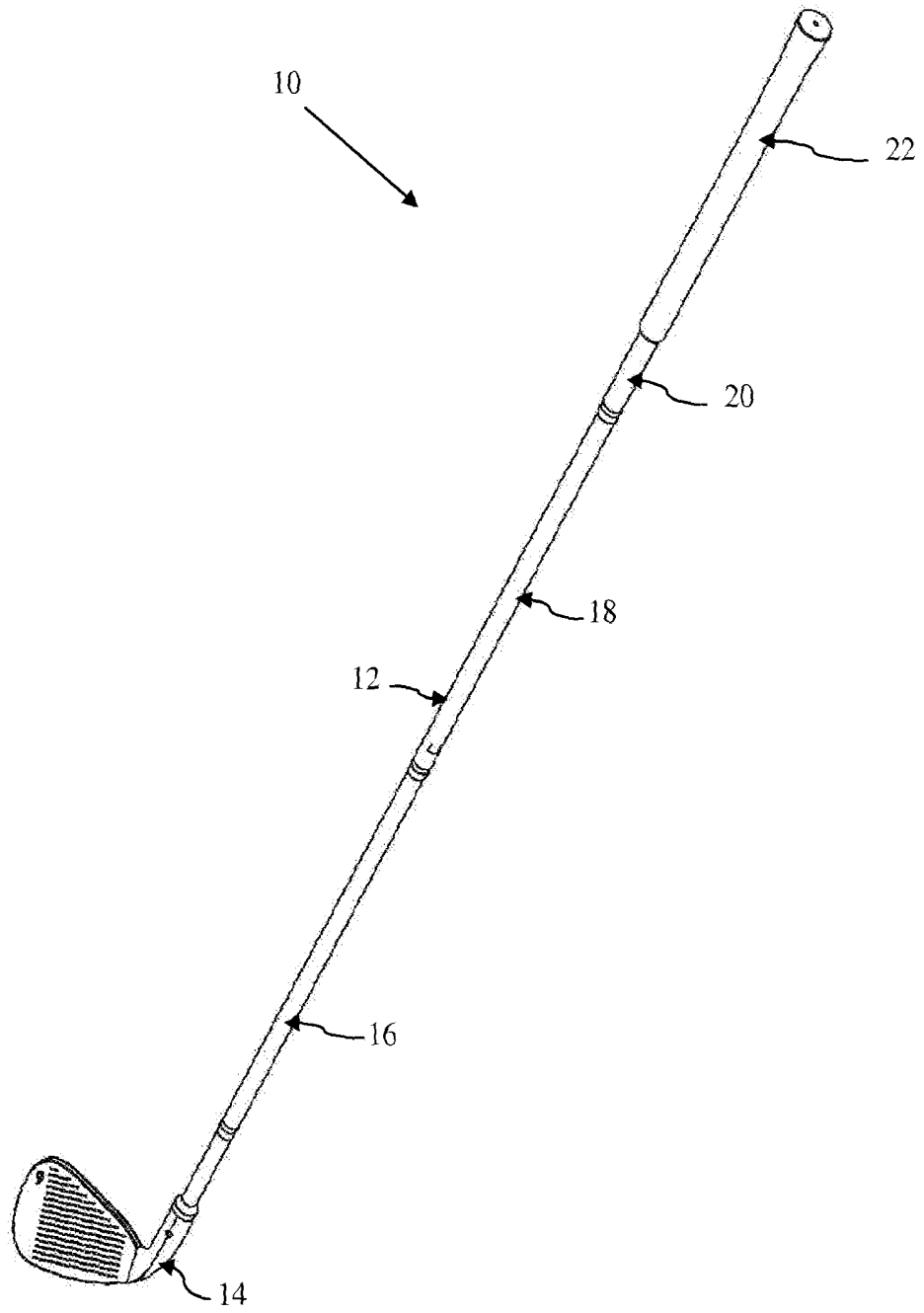

Figure 2

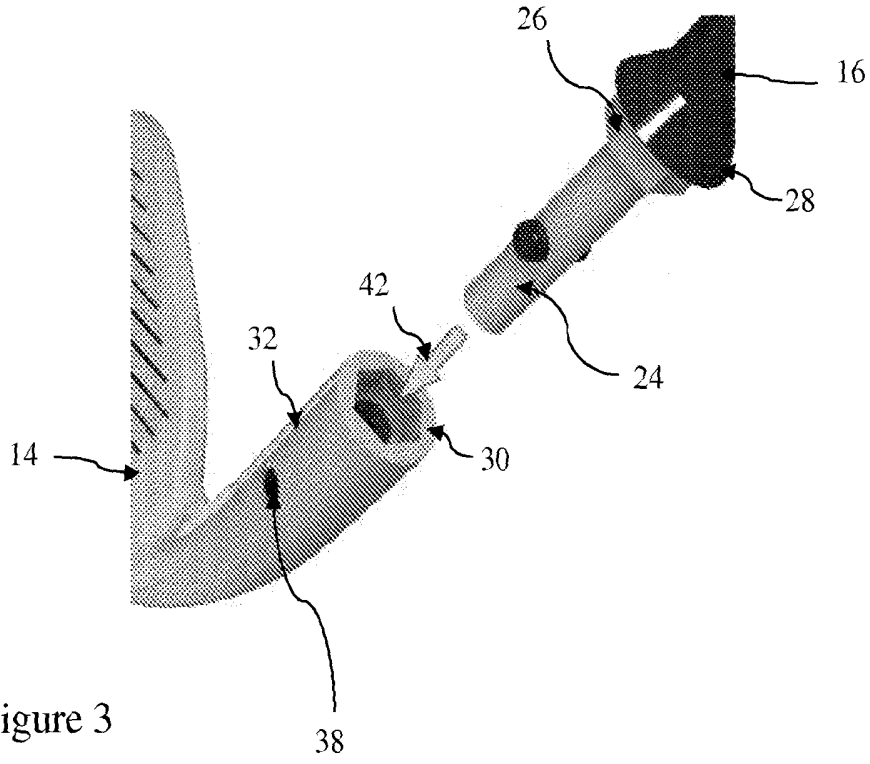

Figure 3

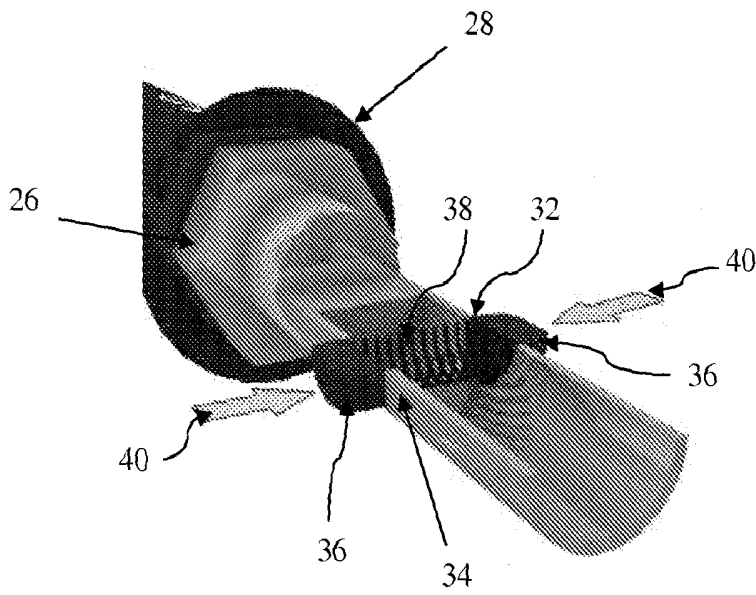

Figure 4

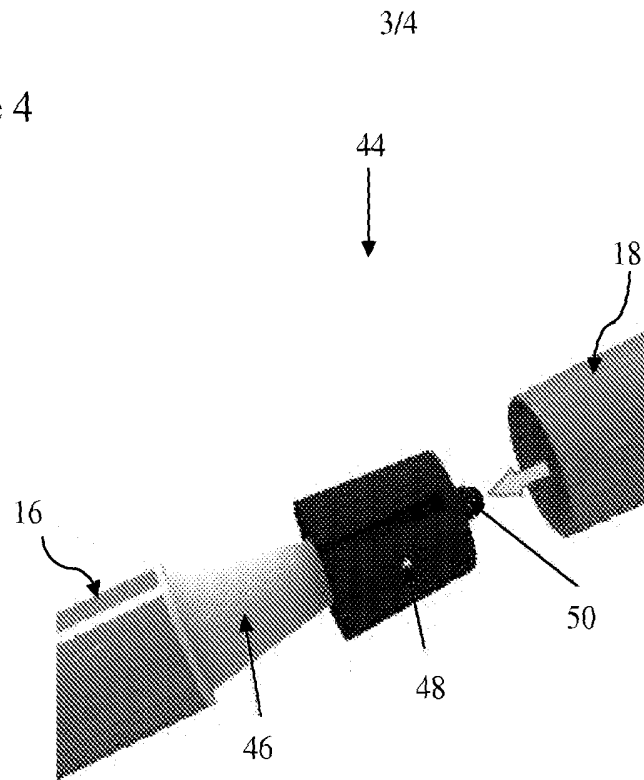

Figure 5

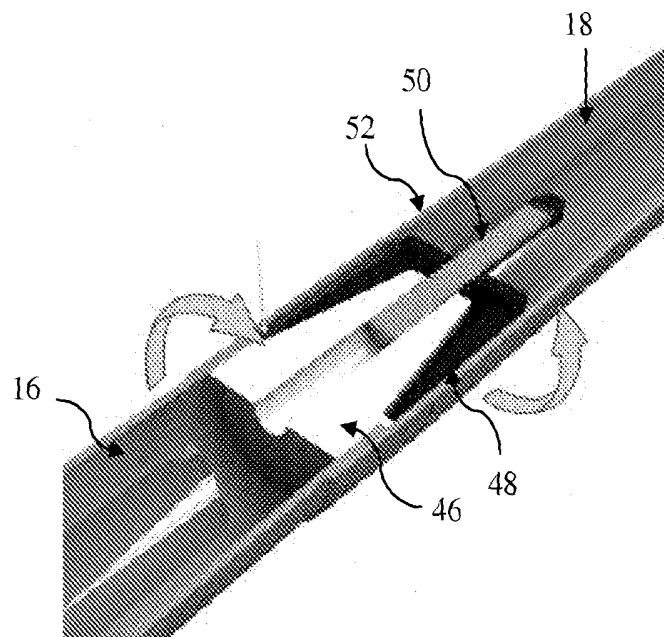
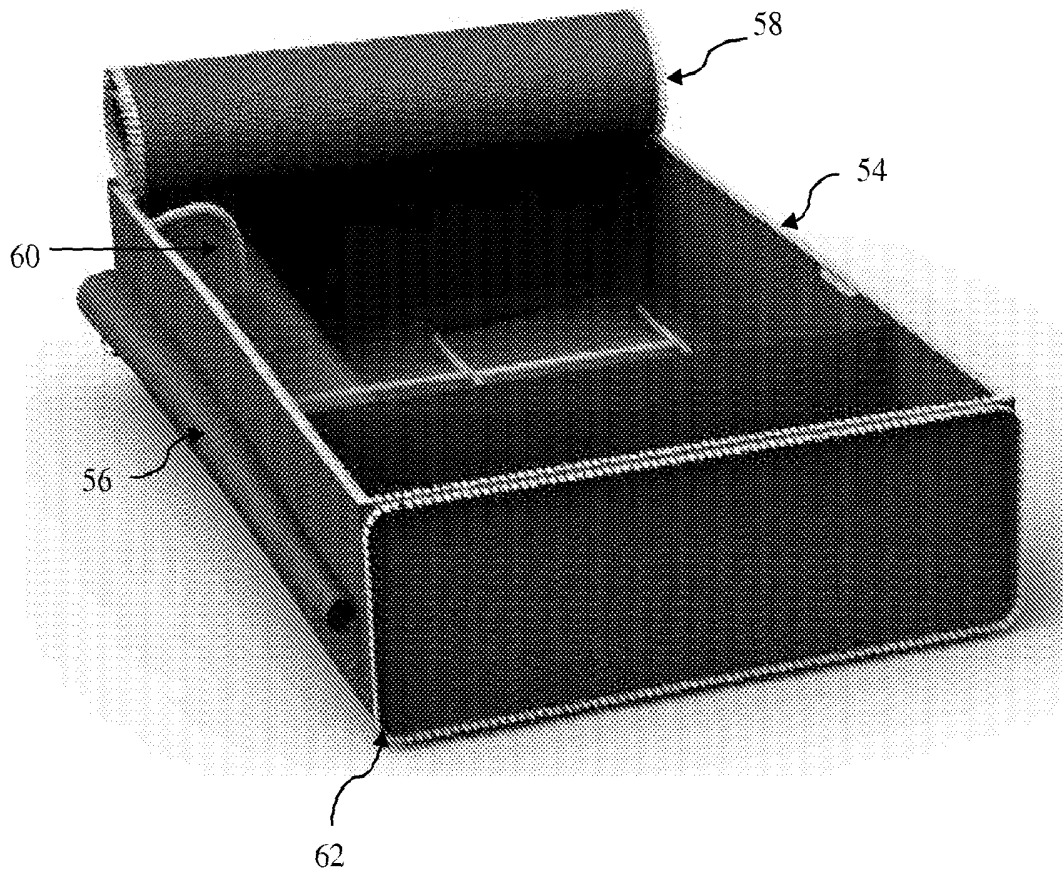

Figure 6



Title: Golf Club

The present invention relates to a golf club.

5 Background to the Invention

Golf is an extremely popular sport and leisure activity, but traditional golf clubs have some significant disadvantages. Golf clubs are necessarily large and are relatively heavy to transport, both on and off the golf course. Golf clubs are often carried as a set in a bag, together with other golfing equipment. A typical golf bag may weigh in
10 excess of 20kg. Often, a manually towed trolley or electrically driven caddie is needed in order to transport the golf clubs and other equipment around a green. Due to their cumbersome nature, golf clubs can also become damaged in transit.

15 Golf clubs are also expensive items, and the cost of a set of clubs increases from basic starter sets through to custom sets for professionals. A problem of starter sets is that they include a full range of clubs, many of which a beginner will never use, and there is often no option to choose particular clubs for inclusion in a set.

20 The majority of golf clubs have a standard length, which may not fit a particular player. Whilst it is possible to have a club made to a custom length, this adds to cost, and usually players resort to changing their playing stance, which may affect their playing performance detrimentally.

25 A typical set of golf clubs is relatively bulky and when carried in a bag with other equipment/accessories, their size can become a problem. For example, a golf bag may not easily fit into the boot of a modern car, and there may not be anywhere suitable to store a golf bag in the home. Similarly, at club venues and schools there is often nowhere to store golfing equipment securely. These problems are exacerbated
30 when going on holiday, because space and weight is usually at a premium. Players with physical limitations also may have difficulties in lifting a golf bag and it may not always be possible for players to transport their golfing equipment, for example, if they have to use public transport, cycles or small compact cars.

It is possible to alleviate these problems to some degree by the rental of golf clubs from a golf club, but again, standard sets are provided, which are not necessarily suited to a particular player.

- 5 It is an object of the invention to provide a golf club and golf club kit which reduces or substantially obviates the above mentioned problems.

Statement of Invention

- 10 According to the first aspect of the present invention there is provided a golf club comprising a collapsible shaft and a removable head.

Advantageously, the collapsible shaft and removable head enable the size of the golf club to be reduced for transit and storage.

- 15 Preferably the collapsible shaft is telescopic and includes at least first and second tubular members which are lockable in any position relative to one another within a range of movement.

- 20 Preferably rotation of the first member relative to the second member in a first direction causes locking of the members and relative rotation in the opposite direction causes unlocking of the members.

- 25 Preferably the telescopic shaft includes a third tubular member, which slides relative to the second tubular member and is lockable at any position relative to the second tubular member within a range of movement.

- 30 Preferably rotation of the second member relative to the third member in a first direction causes locking of the members and relative rotation in the opposite direction because unlocking of the members.

Preferably a grip is disposed on an upper distal end of the shaft.

Preferably a lower distal end of the shaft engages in an aperture in the removable head.

Preferably the removable head is attached to the shaft by means of a releasable latch.

5

Preferably a non-circular element is provided proximate the lower distal end of the shaft and is adapted to engage a corresponding non-circular aperture in the removable head.

10 Preferably the non-circular element is hexagonal.

Preferably a spigot is disposed at the lower distal end of the shaft and is adapted to fit in an aperture in the removable head.

15 Preferably the releasable latch includes at least one lock member biased outwardly from the spigot, the lock member being releasably engageable in a recess in the removable head.

20 Preferably the releasable latch includes a pair of opposed pins extending from either side of the spigot, the pins being releasably engageable in a corresponding recesses in the removable head.

The removable head may be an iron, a putter or a wood.

25 According to a second aspect of the invention there is provided a golfing kit comprising a golf club in accordance with the first aspect of the invention, and further comprising at least one alternative removable head.

30 Preferably the kit includes a plurality of removable heads including at least one iron, a wood and a putter.

Preferably the kit includes a bag for retaining the golf club and removable heads.

Description of the Drawings

5

For a better understanding of the present invention, and to show more clearly how it may be carried into effect, reference will now be made, by way of example, to the accompanying drawings, in which:

10 Figure 1 shows a schematic perspective view of a golf club;

Figure 2 shows a schematic perspective view of the collapsible shaft being fitted to the removable head of the golf club in Figure 1;

15 Figure 3 shows a schematic cut-away view of the end of the collapsible shaft;

Figure 4 shows a schematic perspective view of a locking device between first and second tubular members of the collapsible shaft;

20 Figure 5 shows a schematic perspective cut-away view of the locking device of Figure 4;

Figure 6 shows a bag for retaining the golf club of the invention together with further removable heads and other golfing equipment.

25

Description of Preferred Embodiments

Referring firstly to Figure 1, a golf club is indicated generally at 10. The golf club 10 includes a collapsible telescopic shaft 12 and a removable head 14. The collapsible shaft is made from three tubular members, a first tubular member 16, a second tubular member 18 and a third tubular member 20, which move and lock relative to one another. A foam or rubber grip 22 is provided at the upper distal end of the telescopic shaft 12 on the third tubular member 20.

30

Referring now to Figures 2 and 3, the removable head 14 is an iron, and is releasably attached to the lower end of the first tubular member 16. A spigot 24 is disposed at the lower distal end of the tubular member 16 which extends upwards into a hexagonal element or formation 26 which lies underneath a peripheral flange 28. An aperture 30 is disposed in the end of a shaft portion 32 of the head 14, the upper end of the aperture being hexagonal to receive the hexagonal formation 26 and the hexagonal part of the aperture extending into a circular aperture for receiving the spigot 24. Referring now in particular to Figure 3, a through aperture 34 is provided through a diameter of the spigot 24 and receives a pair of pins 36 which are spring biased out of the aperture 34 on either side of the spigot 24. The pins 36 are biased by a spring 38, which is located internally of the spigot 24. The pins 36 have peripheral flanges at their rear, or inside edges, thereby preventing the pins from being pushed out of the aperture 34. A corresponding aperture 38 is provided through a diameter of the shaft element 32 for receiving the pins 36 when the spigot 24 is fully engaged in the aperture 30.

To assemble the removable head 14 with the telescopic shaft 12, the pins 36 are pressed inwardly as indicated by the arrows 40 in Figure 3, and the spigot is then inserted in the aperture 30 as indicated by the arrow 42 in Figure 2. The hexagonal formation 26 fits with a clearance fit in the upper end of the aperture 30 and the spigot 24 similarly locates with a clearance fit in the circular aperture beneath. When the pins 36 are in alignment with the aperture 38, then they are biased outwardly by the spring 38 and extend between the spigot 24 and shaft portion 32 of the head 14, thereby locking the lower end of the telescopic shaft 12 to the removable head 14.

Referring now to Figures 4 and 5, a locking device for locking the tubular members 16, 18 together is indicated generally at 44. A similar locking device 44 is used to lock the second and third tubular members 18, 20 together. A conical shaft 46 is mounted to the upper end of the first tubular member 16, which is apertured at its centre to receive one end of a threaded rod 50, shown in Figure 5. The threaded rod is rigidly fixed in the conical shaft 46, i.e. does not rotate relative thereto. A tapered hollow cone 48 is disposed around the outer conical surface of the conical shaft 46 and is sized to fit within the tubular member 18. The threaded rod 50 is threadingly engaged with an aperture 52 through the centre of the tapered hollow cone 48. In use,

the tapered hollow cone 48 is a tight sliding fit within the inside of the wall of the tubular member 18, and rotates with the tubular member 18, as it is rotated. Therefore, if the shaft 16 is held relative to the rotation of the shaft 18, then the tapered hollow cone is drawn down onto the conical shaft 46, causing the tapered hollow cone to expand further against the side walls of the tubular member 18, thereby locking the tubular members 16 and 18 together. Rotation in the opposite direction causes release of the tapered hollow cone from the conical shaft 46, thereby releasing the tapered hollow cone from the wall of the upper tubular member 18. This arrangement allows the shaft 18 to freely slide over the shaft 16 when the tapered hollow cone and conical shaft are not engaged, but locks them together when the tapered hollow cone 48 is expanded by the conical shaft. The tubular member 20 is able to slide over the tubular member 18 in similar manner, thereby providing for telescopic extension and contraction of the shaft 12. It will be appreciated that the telescopic shaft can be locked in any one of an infinite number of positions, providing a length of shaft suitable for a player of any height.

Markings are provided on the first tubular member 16, which correspond to lengths of standard gold clubs. For example, if the second and third tubular members 18,20 are locked in a fully extended position, and the first tubular member 16 is partially extended to the marking for a 7-iron, then if a 7-iron head is attached to the spigot 24, then the combined length of the shaft and head will be the same as that for a standard 7-iron. Similarly, markings are provided for other clubs, such as drivers and putters. The markings can optionally be provided on either of the other tubular members, but ideally the markings are provided on the first, lower tubular member, as described.

Referring now to Figure 6, a bag 54 is provided for carrying the golf club 10, a plurality of removable heads 14 and other accessories, for example golf balls and tees. The bag is substantially rectangular with a handle provided at its upper end, (not shown). A sleeve 56 is provided along one edge of the bag 54 for receiving and retaining the telescopic shaft 12. One side panel 58 of the bag is detachable on three sides by means of a zip 58, which provides access to the inside of the bag. The internal cavity of the bag is divided into compartments 60 for receiving alternative removable golf heads, such as irons of different weights, woods and a putter. Storage for golf balls is also provided together with storage for tees. Side pockets may be

provided along the other side of the bag 54 (not shown) for holding valuables and other items. The side pockets may be sealed with hook and eye fastener, for example Velcro (RTM). On the reverse of the bag, a transparent score card holder and map holder is provided, thus enabling a score card and map to be conveniently viewed, 5 whilst playing a game of golf. A further zip 62 is provided around the periphery of the base of the bag, for receiving an optional extra storage pouch, for example, for driver storage.

The bag 54 is of a size similar to a typical sports holdall, and is approximately 0.6m 10 by 0.4m by 0.2m. The bag is designed to contain a telescopic shaft 12, as described together with up to 13 different club heads, a score card, golf balls, tees, markers, gloves, pitch repairer, towel, keys, wallet, phone, drinks, and an iPod. The bag may also be provided with a waist strap and shoulder strap as well as the upper carrying handle.

15

The golf club 10 is advantageous, because only one shaft 12 is required to play with any number of different removable heads 14. Furthermore, due to the collapsible nature of the shaft 12, the weight and space required for a full set of golfing clubs is significantly reduced. Players can also choose from a large number of removable 20 heads, when purchasing a kit of parts for playing golf, and can therefore achieve a customised set of golf clubs at much lower cost than is currently possible. The greatly reduced size of golfing equipment alleviates the aforementioned problems of storage and carriage and avoids the need for expensive caddy devices whilst on the golf course. The golf club 10 is particularly useful for new players, allowing affordable 25 entry into the game, and for casual players and school children. The adjustable length of the golf club 10 is a particularly advantageous for players requiring a custom length of golf club, other than that provided as standard in the industry.

CLAIMS

1. A golf club comprising a collapsible shaft and a removable head.
- 5 2. A golf club as claimed in claim 1, in which the collapsible shaft is telescopic and includes at least first and second tubular members which are lockable at any position relative to one another within a range of movement.
3. A golf club as claimed in claim 2, in which rotation of the first member
10 relative to the second member in a first direction causes locking of the members and relative rotation in the opposite direction cause unlocking of the members.
4. A golf club as claimed in claim 2 or claim 3, in which the telescopic shaft
15 includes a third tubular member, which slides relative to the second tubular member and is lockable at any position relative to the second tubular member within a range of movement.
5. A golf club as claimed in claim 4, in which rotation of the second member
20 relative to the third member in a first direction causes locking of the members and relative rotation in the opposite direction cause unlocking of the members.
6. A golf club as claimed in any preceding claim, in which a grip is disposed on an upper distal end of the shaft.
- 25 7. A golf club as claimed in any preceding claim, in which a lower distal end of the shaft engages in an aperture in the removable head.
8. A golf club as claimed in any preceding claim, in which the removable head is attached to the shaft by means of a releasable latch.
- 30 9. A golf club as claimed in claim 8, in which a non-circular element is provided proximate the lower distal end of the shaft and is adapted to engage a corresponding non-circular aperture in the removable head.

10. A golf club as claimed in claim 9, in which the non-circular formation is hexagonal.

11. A golf club as claimed in any preceding claim, in which a spigot is disposed at the lower distal end of the shaft and is adapted to fit in an aperture in the removable head.

12. A golf club as claimed in claim 11, when dependent on claim 8, in which the releasable latch includes at least one lock member biased outwardly from the spigot, the lock member being releasably engageable in a recess in the removable head.

13. A golf club as claimed in claim 12, in which the releasable latch includes a pair of opposed pins extending from either side of the spigot, the pins being releasably engageable in a corresponding recesses in the removable head.

14. A golf club as claimed in any preceding claim, in which the removable head is an iron, a putter or a wood.

15. A golfing kit comprising a golf club as claimed in any preceding claim, and further comprising at least one alternative removable head.

16. A golfing kit as claimed in claim 15, in which a plurality of removable heads are provided including at least one iron, a wood and a putter.

17. A golfing kit as claimed in claim 15, further comprising a bag for retaining the golf club and removable heads.

18. A golf club substantially as described herein with reference to and as illustrated in Figures 1 to 6 of the accompanying drawings.

30

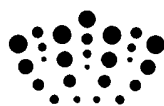

Application No: GB0904878.6
Claims searched: 1-18

Examiner: Dr David Palmer
Date of search: 15 June 2009

Patents Act 1977: Search Report under Section 17

Documents considered to be relevant:

Category	Relevant to claims	Identity of document and passage or figure of particular relevance
X,Y	X: 1, 6, 8, 14-17; Y: 2-5, 9-10	US 4253666 A (MURPHY) See whole document.
X,Y	X: 1, 6-8, 11, 12, 14-17; Y: 2-5, 9-10	US 3829092 A (ARKIN) See whole document.
Y	2-5, 9-10	US 2007/293340 A1 (CHENG) See whole document.
Y	9, 10	JP 2005270402 A1 (DAIWA SEIKO) 06-10-05 (See the figures and EPODOC abstract).
Y	9	US 2009/075748 A1 (EVANS et al) See whole document.

Categories:

X	Document indicating lack of novelty or inventive step	A	Document indicating technological background and/or state of the art.
Y	Document indicating lack of inventive step if combined with one or more other documents of same category.	P	Document published on or after the declared priority date but before the filing date of this invention.
&	Member of the same patent family	E	Patent document published on or after, but with priority date earlier than, the filing date of this application.

Field of Search:

Search of GB, EP, WO & US patent documents classified in the following areas of the UKC^X:

--

Worldwide search of patent documents classified in the following areas of the IPC

A63B

The following online and other databases have been used in the preparation of this search report

EPODOC, WPI

International Classification:

Subclass	Subgroup	Valid From
----------	----------	------------

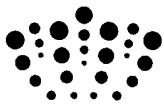

Subclass	Subgroup	Valid From
A63B	0053/10	01/01/2006
A63B	0053/02	01/01/2006