



US 20090213790A1

(19) **United States**

(12) **Patent Application Publication**
Barriac

(10) **Pub. No.: US 2009/0213790 A1**

(43) **Pub. Date: Aug. 27, 2009**

(54) **METHOD AND APPARATUS FOR
PROCESSING A MULTI-CODE WORD
ASSIGNMENT IN WIRELESS
COMMUNICATION SYSTEMS**

Related U.S. Application Data

(60) Provisional application No. 60/731,037, filed on Oct. 27, 2005.

(75) Inventor: **Gwendolyn D. Barriac**, San Diego, CA (US)

Publication Classification

(51) **Int. Cl.**
H04W 4/00 (2009.01)

Correspondence Address:
TUROC & WATSON, LLP
127 Public Square, 57th Floor, Key Tower
Cleveland, OH 44114 (US)

(52) **U.S. Cl.** **370/328**

(73) Assignee: **QUALCOMM
INCORPORATED**, San Diego, CA (US)

(57) **ABSTRACT**

A method and apparatus for processing a Multi-code word assignment is provided, comprising receiving a MCW-FLAB1, determining value of supplemental field in the MCW-FLAB1 received with a MACID of an access terminal from the SS MAC protocol with a supplemental field, determining whether a MCW-FLAB2 is received with MACID in a same PHY frame and processing the MCW-FLAB1 based upon whether the MCW-FLAB2 is received and the value of the supplemental field.

(21) Appl. No.: **12/091,476**

(22) PCT Filed: **Oct. 27, 2006**

(86) PCT No.: **PCT/US06/41869**

§ 371 (c)(1),
(2), (4) Date: **Oct. 6, 2008**

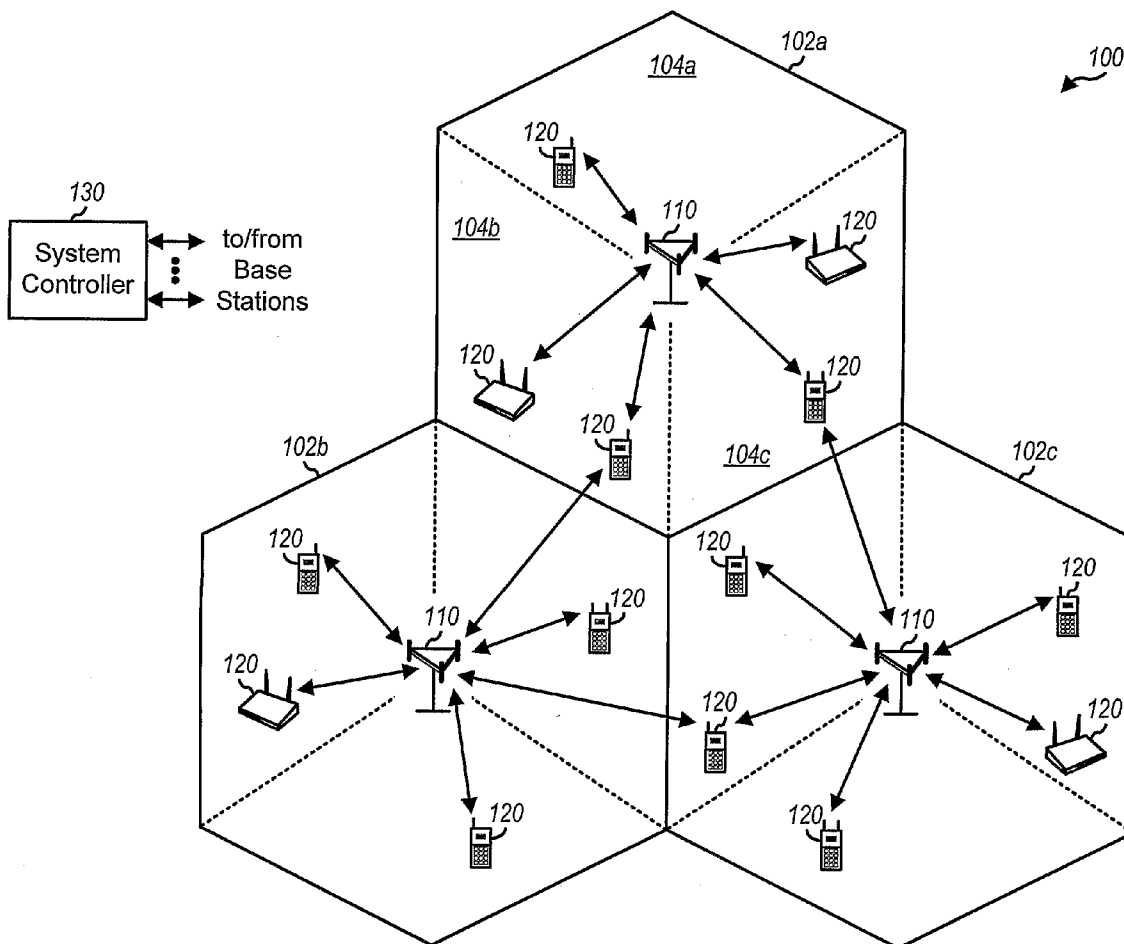

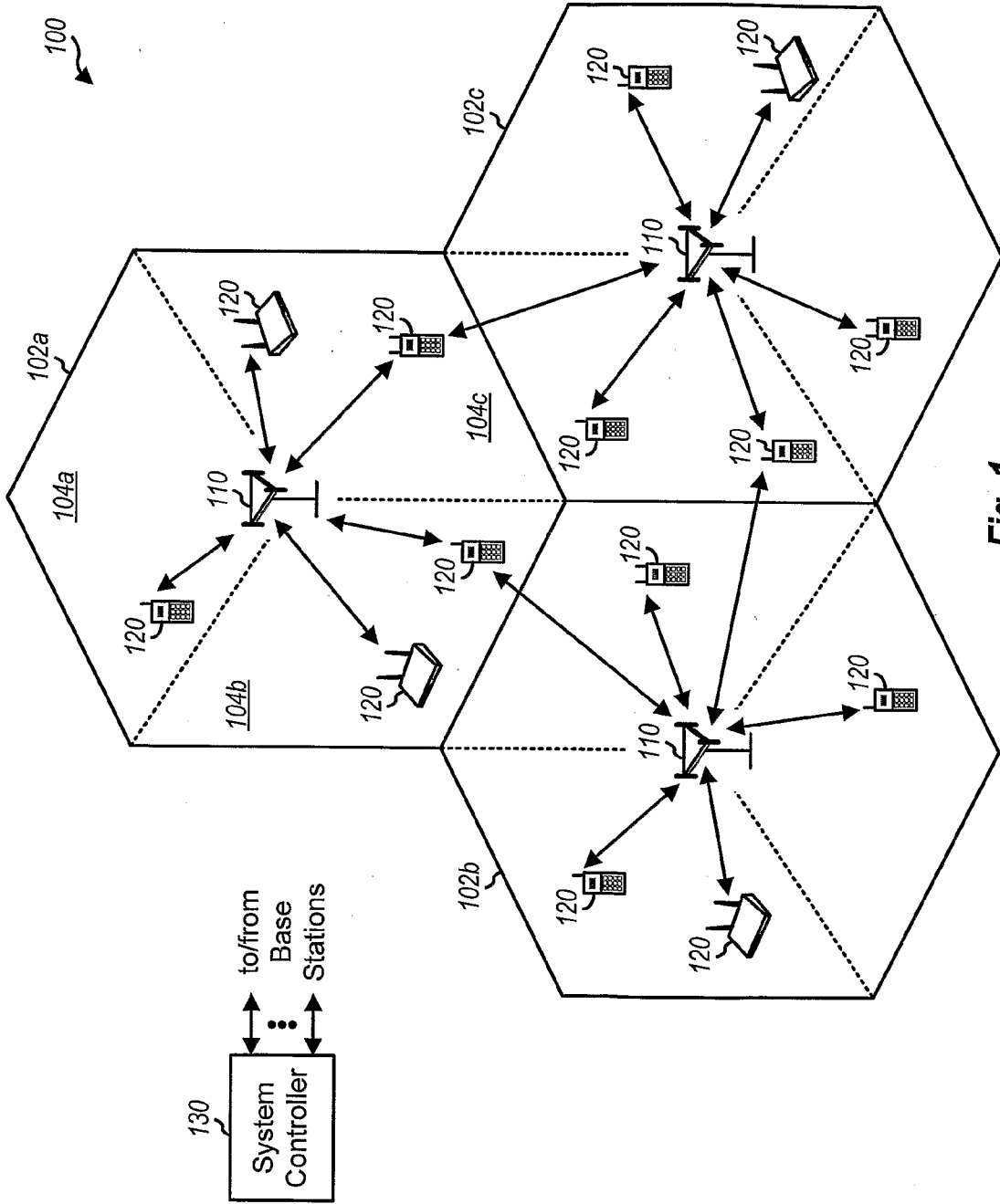

Fig. 1

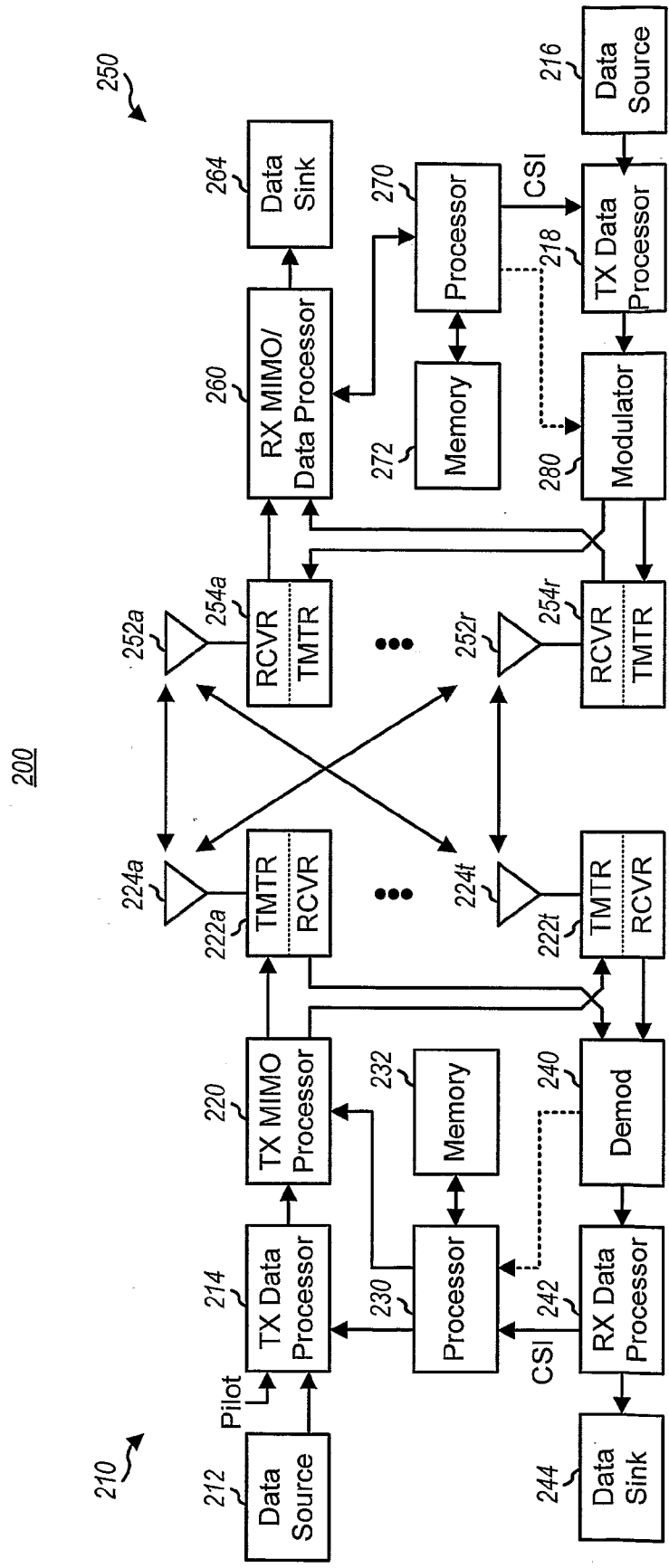

Fig 2

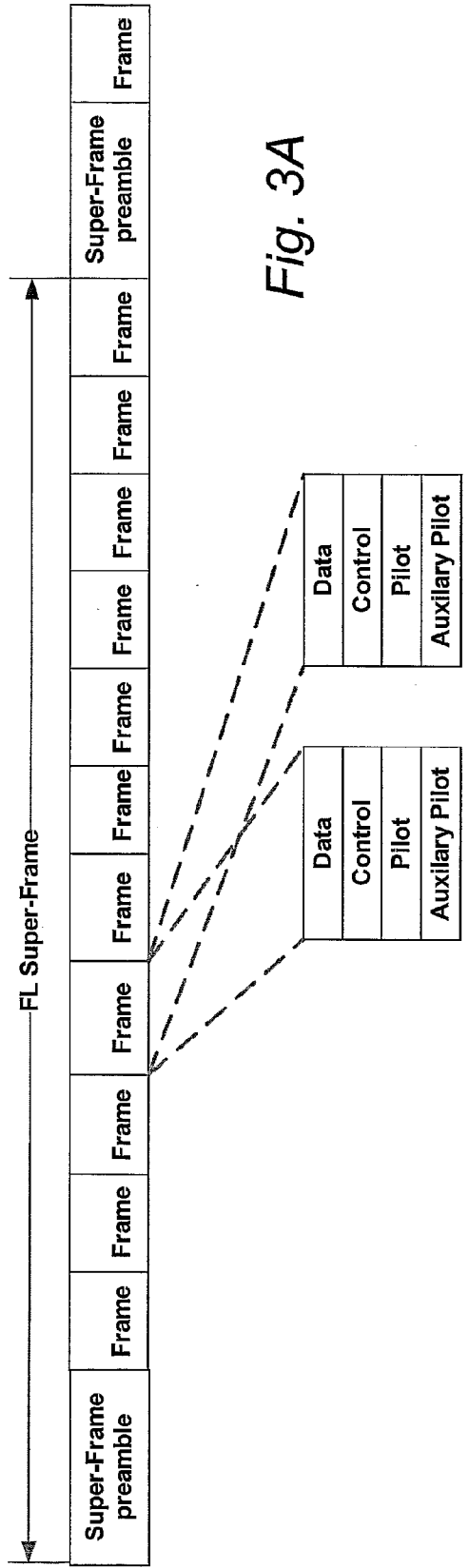

Fig. 3A

Block Hopping mode Symbol Rate Hopping mode

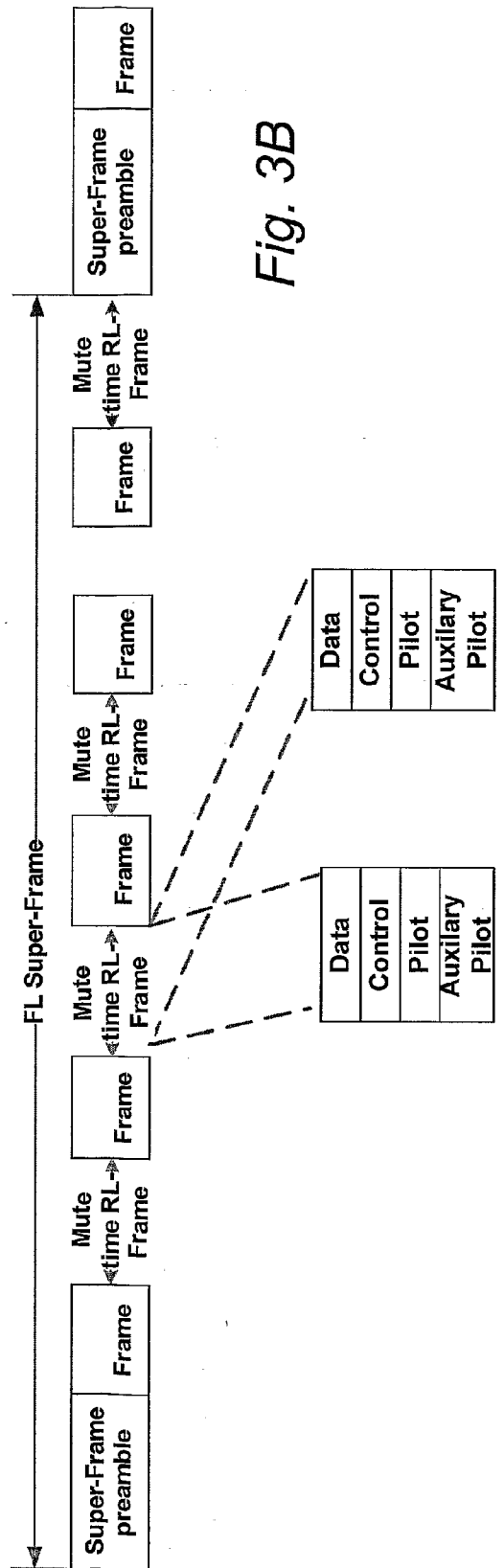

Fig. 3B

Block Hopping mode Symbol Rate Hopping mode

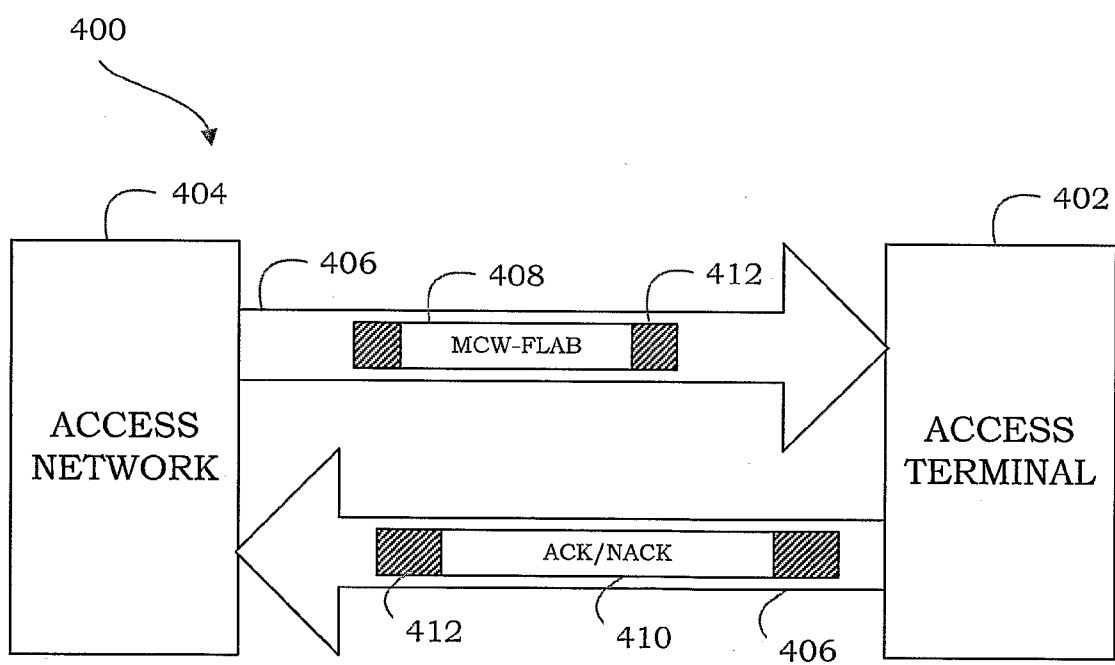

FIGURE 4

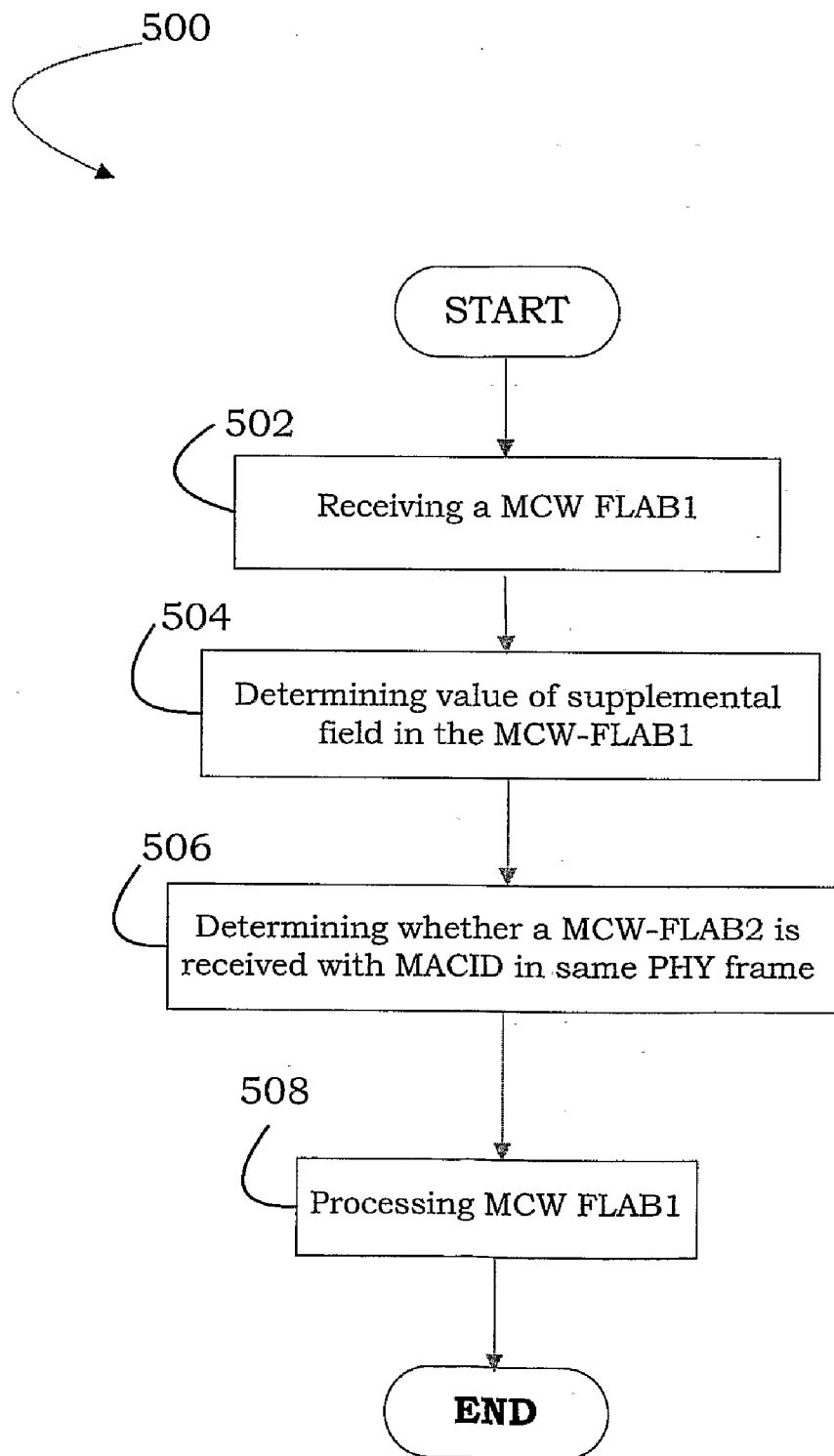

FIGURE 5A

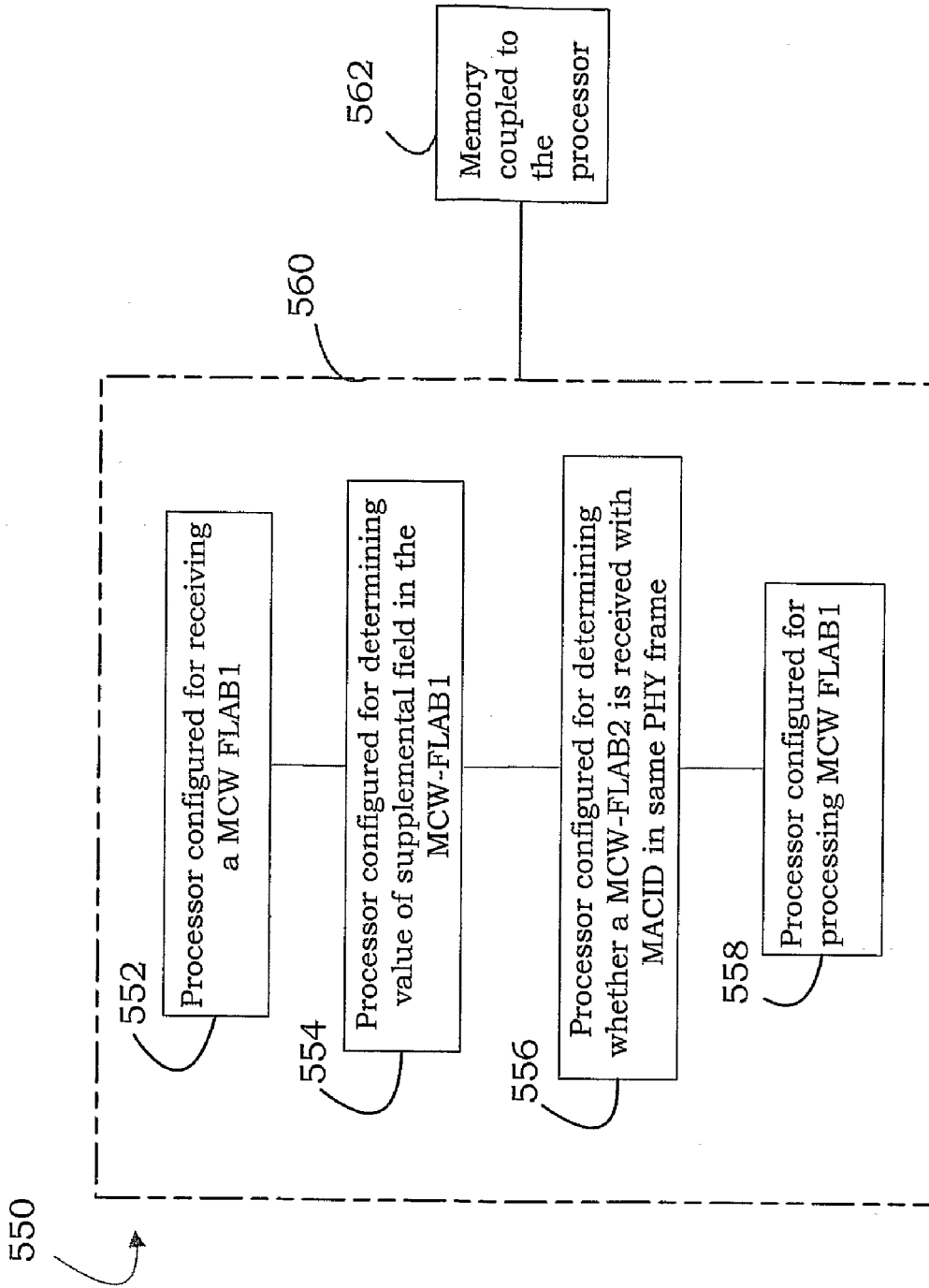

FIGURE 5B

METHOD AND APPARATUS FOR PROCESSING A MULTI-CODE WORD ASSIGNMENT IN WIRELESS COMMUNICATION SYSTEMS

[0001] The present Application for Patent claims priority to Provisional Application Ser. No. 60/731,037, entitled "METHODS AND APPARATUS FOR PROVIDING MOBILE BROADBAND WIRELESS HIGHER MAC", filed Oct. 27, 2005, assigned to the assignee hereof, and expressly incorporated herein by reference.

BACKGROUND

[0002] 1. Field

[0003] The present disclosure relates generally to wireless communication and more particularly to method and apparatus for processing a Multi-code word assignment by an access terminal.

[0004] 2. Background

[0005] Wireless communication systems have become a prevalent means by which a majority of people worldwide have come to communicate. Wireless communication devices have become smaller and more powerful in order to meet consumer needs and to improve portability and convenience. The increase in processing power in mobile devices such as cellular telephones has lead to an increase in demands on wireless network transmission systems. Such systems typically are not as easily updated as the cellular devices that communicate there over. As mobile device capabilities expand, it can be difficult to maintain an older wireless network system in a manner that facilitates fully exploiting new and improved wireless device capabilities.

[0006] Wireless communication systems generally utilize different approaches to generate transmission resources in the form of channels. These systems may be code division multiplexing (CDM) systems, frequency division multiplexing (FDM) systems, and time division multiplexing (TDM) systems. One commonly utilized variant of FDM is orthogonal frequency division multiplexing (OFDM) that effectively partitions the overall system bandwidth into multiple orthogonal subcarriers. These subcarriers may also be referred to as tones, bins, and frequency channels. Each subcarrier can be modulated with data. With time division based techniques, a each subcarrier can comprise a portion of sequential time slices or time slots. Each user may be provided with a one or more time slot and subcarrier combinations for transmitting and receiving information in a defined burst period or frame. The hopping schemes may generally be a symbol rate hopping scheme or a block hopping scheme.

[0007] Code division based techniques typically transmit data over a number of frequencies available at any time in a range. In general, data is digitized and spread over available bandwidth, wherein multiple users can be overlaid on the channel and respective users can be assigned a unique sequence code. Users can transmit in the same wide-band chunk of spectrum, wherein each user's signal is spread over the entire bandwidth by its respective unique spreading code. This technique can provide for sharing, wherein one or more users can concurrently transmit and receive. Such sharing can be achieved through spread spectrum digital modulation, wherein a user's stream of bits is encoded and spread across a very wide channel in a pseudo-random fashion. The receiver is designed to recognize the associated unique sequence code

and undo the randomization in order to collect the bits for a particular user in a coherent manner.

[0008] A typical wireless communication network (e.g., employing frequency, time, and/or code division techniques) includes one or more base stations that provide a coverage area and one or more mobile (e.g., wireless) terminals that can transmit and receive data within the coverage area. A typical base station can simultaneously transmit multiple data streams for broadcast, multicast, and/or unicast services, wherein a data stream is a stream of data that can be of independent reception interest to a mobile terminal. A mobile terminal within the coverage area of that base station can be interested in receiving one, more than one or all the data streams transmitted from the base station. Likewise, a mobile terminal can transmit data to the base station or another mobile terminal. In these systems the bandwidth and other system resources are assigned utilizing a scheduler.

[0009] The signals, signal formats, signal exchanges, methods, processes, and techniques disclosed herein provide several advantages over known approaches. These include, for example, reduced signaling overhead, improved system throughput, increased signaling flexibility, reduced information processing, reduced transmission bandwidth, reduced bit processing, increased robustness, improved efficiency, and reduced transmission power

SUMMARY

[0010] The following presents a simplified summary of one or more aspects in order to provide a basic understanding of such aspects. This summary is not an extensive overview of all contemplated aspects, and is intended to neither identify key or critical elements of all aspects nor delineate the scope of any or all aspects. Its sole purpose is to present some concepts of one or more aspects in a simplified form as a prelude to the more detailed description that is presented later.

[0011] According to an embodiment, a method is provided for processing a Multi-code word assignment, the method comprising receiving a MCW-FLAB1, determining value of supplemental field in the MCW-FLAB1 received with a MACID of an access terminal from the SS MAC protocol with a supplemental field, determining whether a MCW-FLAB2 is received with MACID in a same PHY frame and processing the MCW-FLAB1 based upon whether the MCW-FLAB2 is received and the value of the supplemental field.

[0012] According to another embodiment, a computer-readable medium is described having a first set of instructions for receiving a MCW-FLAB1, a second set of instructions for determining value of supplemental field in the MCW-FLAB1 received with a MACID of an access terminal from the SS MAC protocol with a supplemental field, a third set of instructions for determining whether a MCW-FLAB2 is received with MACID in a same PHY frame, and a fourth set of instructions for processing the MCW-FLAB1 based upon whether the MCW-FLAB2 is received and the value of the supplemental field.

[0013] According to yet another embodiment, an apparatus operable in a wireless communication system is described which includes means for receiving a MCW-FLAB1, means for determining value of supplemental field in the MCW-FLAB1 received with a MACID of an access terminal from the SS MAC protocol with a supplemental field, means for determining whether a MCW-FLAB2 is received with MACID in a same PHY frame and means for processing the

MCW-FLAB1 based upon whether the MCW-FLAB2 is received and the value of the supplemental field.

[0014] To the accomplishment of the foregoing and related ends, the one or more aspects comprise the features herein-after fully described and particularly pointed out in the claims. The following description and the annexed drawings set forth in detail certain illustrative aspects of the one or more aspects. These aspects are indicative, however, of but a few of the various ways in which the principles of various aspects may be employed and the described aspects are intended to include all such aspects and their equivalents.

BRIEF DESCRIPTION OF THE DRAWINGS

[0015] FIG. 1 illustrates aspects of a multiple access wireless communication system.

[0016] FIG. 2 illustrates aspects of a transmitter and receiver in a multiple access wireless communication system.

[0017] FIGS. 3A and 3B illustrate aspects of superframe structures for a multiple access wireless communication system.

[0018] FIG. 4 illustrates aspect of communication between an access terminal and an access network

[0019] FIG. 5A illustrates a flow diagram of a process by an access terminal.

[0020] FIG. 5B illustrates one or more processors configured for processing Multi-code word assignment.

DETAILED DESCRIPTION

[0021] Various aspects are now described with reference to the drawings, wherein like reference numerals are used to refer to like elements throughout. In the following description, for purposes of explanation, numerous specific details are set forth in order to provide a thorough understanding of one or more aspects. It may be evident, however, that such aspect(s) may be practiced without these specific details. In other instances, well-known structures and devices are shown in block diagram form in order to facilitate describing one or more aspects.

[0022] Referring to FIG. 1, a multiple access wireless communication system according to one aspect is illustrated. A multiple access wireless communication system 100 includes multiple cells, e.g. cells 102, 104, and 106. In the aspect of FIG. 1, each cell 102, 104, and 106 may include an access point 150 that includes multiple sectors. The multiple sectors are formed by groups of antennas each responsible for communication with access terminals in a portion of the cell. In cell 102, antenna groups 112, 114, and 116 each correspond to a different sector. In cell 104, antenna groups 118, 120, and 122 each correspond to a different sector. In cell 106, antenna groups 124, 126, and 128 each correspond to a different sector.

[0023] Each cell includes several access terminals which are in communication with one or more sectors of each access point. For example, access terminals 130 and 132 are in communication base 142, access terminals 134 and 136 are in communication with access point 144, and access terminals 138 and 140 are in communication with access point 146.

[0024] Controller 130 is coupled to each of the cells 102, 104, and 106. Controller 130 may contain one or more connections to multiple networks, e.g. the Internet, other packet based networks, or circuit switched voice networks that provide information to, and from, the access terminals in communication with the cells of the multiple access wireless

communication system 100. The controller 130 includes, or is coupled with, a scheduler that schedules transmission from and to access terminals. In other aspects, the scheduler may reside in each individual cell, each sector of a cell, or a combination thereof.

[0025] As used herein, an access point may be a fixed station used for communicating with the terminals and may also be referred to as, and include some or all the functionality of, a base station, a Node B, or some other terminology. An access terminal may also be referred to as, and include some or all the functionality of, a user equipment (UE), a wireless communication device, terminal, a mobile station or some other terminology.

[0026] It should be noted that while FIG. 1, depicts physical sectors, i.e. having different antenna groups for different sectors, other approaches may be utilized. For example, utilizing multiple fixed “beams” that each cover different areas of the cell in frequency space may be utilized in lieu of, or in combination with physical sectors. Such an approach is depicted and disclosed in co-pending U.S. patent application Ser. No. 11/260,895, entitled “Adaptive Sectorization in Cellular System.”

[0027] Referring to FIG. 2, a block diagram of an aspect of a transmitter system 210 and a receiver system 250 in a MIMO system 200 is illustrated. At transmitter system 210, traffic data for a number of data streams is provided from a data source 212 to transmit (TX) data processor 214. In an aspect, each data stream is transmitted over a respective transmit antenna. TX data processor 214 formats, codes, and interleaves the traffic data for each data stream based on a particular coding scheme selected for that data stream to provide coded data.

[0028] The coded data for each data stream may be multiplexed with pilot data using OFDM, or other orthogonalization or non-orthogonalization techniques. The pilot data is typically a known data pattern that is processed in a known manner and may be used at the receiver system to estimate the channel response. The multiplexed pilot and coded data for each data stream is then modulated (i.e., symbol mapped) based on one or more particular modulation schemes (e.g., BPSK, QSPK, M-PSK, or M-QAM) selected for that data stream to provide modulation symbols. The data rate, coding, and modulation for each data stream may be determined by instructions performed on provided by processor 230.

[0029] The modulation symbols for all data streams are then provided to a TX processor 220, which may further process the modulation symbols (e.g., for OFDM). TX processor 220 then provides N_T modulation symbol streams to N_T transmitters (TMTR) 222a through 222t. Each transmitter 222 receives and processes a respective symbol stream to provide one or more analog signals, and further conditions (e.g., amplifies, filters, and upconverts) the analog signals to provide a modulated signal suitable for transmission over the MIMO channel. N_T modulated signals from transmitters 222a through 222t are then transmitted from N_T antennas 224a through 224t, respectively.

[0030] At receiver system 250, the transmitted modulated signals are received by N_R antennas 252a through 252r and the received signal from each antenna 252 is provided to a respective receiver (RCVR) 254. Each receiver 254 conditions (e.g., filters, amplifies, and downconverts) a respective received signal, digitizes the conditioned signal to provide samples, and further processes the samples to provide a corresponding “received” symbol stream.

[0031] An RX data processor **260** then receives and processes the N_R received symbol streams from N_R receivers **254** based on a particular receiver processing technique to provide N_T “detected” symbol streams. The processing by RX data processor **260** is described in further detail below. Each detected symbol stream includes symbols that are estimates of the modulation symbols transmitted for the corresponding data stream. RX data processor **260** then demodulates, deinterleaves, and decodes each detected symbol stream to recover the traffic data for the data stream. The processing by RX data processor **218** is complementary to that performed by TX processor **220** and TX data processor **214** at transmitter system **210**.

[0032] RX data processor **260** may be limited in the number of subcarriers that it may simultaneously demodulate, e.g. **512** subcarriers or 5 MHz, and such a receiver should be scheduled on a single carrier. This limitation may be a function of its FFT range, e.g. sample rates at which the processor **260** may operate, the memory available for FFT, or other functions available for demodulation. Further, the greater the number of subcarriers utilized, the greater the expense of the access terminal.

[0033] The channel response estimate generated by RX processor **260** may be used to perform space, space/time processing at the receiver, adjust power levels, change modulation rates or schemes, or other actions. RX processor **260** may further estimate the signal-to-noise-and-interference ratios (SNRs) of the detected symbol streams, and possibly other channel characteristics, and provides these quantities to a processor **270**. RX data processor **260** or processor **270** may further derive an estimate of the “operating” SNR for the system. Processor **270** then provides channel state information (CSI), which may comprise various types of information regarding the communication link and/or the received data stream. For example, the CSI may comprise only the operating SNR. In other aspects, the CSI may comprise a channel quality indicator (CQI), which may be a numerical value indicative of one or more channel conditions. The CSI is then processed by a TX data processor **278**, modulated by a modulator **280**, conditioned by transmitters **254a** through **254r**, and transmitted back to transmitter system **210**.

[0034] At transmitter system **210**, the modulated signals from receiver system **250** are received by antennas **224**, conditioned by receivers **222**, demodulated by a demodulator **240**, and processed by a RX data processor **242** to recover the CSI reported by the receiver system. The reported CSI is then provided to processor **230** and used to (1) determine the data rates and coding and modulation schemes to be used for the data streams and (2) generate various controls for TX data processor **214** and TX processor **220**. Alternatively, the CSI may be utilized by processor **270** to determine modulation schemes and/or coding rates for transmission, along with other information. This may then be provided to the transmitter which uses this information, which may be quantized, to provide later transmissions to the receiver.

[0035] Processors **230** and **270** direct the operation at the transmitter and receiver systems, respectively. Memories **232** and **272** provide storage for program codes and data used by processors **230** and **270**, respectively.

[0036] At the receiver, various processing techniques may be used to process the N_R received signals to detect the N_T transmitted symbol streams. These receiver processing techniques may be grouped into two primary categories (i) spatial and space-time receiver processing techniques (which are

also referred to as equalization techniques); and (ii) “successive nulling/equalization and interference cancellation” receiver processing technique (which is also referred to as “successive interference cancellation” or “successive cancellation” receiver processing technique).

[0037] While FIG. **2** discusses a MIMO system, the same system may be applied to a multi-input single-output system where multiple transmit antennas, e.g., those on a base station, transmit one or more symbol streams to a single antenna device, e.g. a mobile station. Also, a single output to single input antenna system may be utilized in the same manner as described with respect to FIG. **2**.

[0038] The transmission techniques described herein may be implemented by various means. For example, these techniques may be implemented in hardware, firmware, software, or a combination thereof. For a hardware implementation, the processing units at a transmitter may be implemented within one or more application specific integrated circuits (ASICs), digital signal processors (DSPs), digital signal processing devices (DSPDs), programmable logic devices (PLDs), field programmable gate arrays (FPGAs), processors, controllers, micro-controllers, microprocessors, electronic devices, other electronic units designed to perform the functions described herein, or a combination thereof. The processing units at a receiver may also be implemented within one or more ASICs, DSPs, processors, and so on.

[0039] For a software implementation, the transmission techniques may be implemented with modules (e.g., procedures, functions, and so on) that perform the functions described herein. The software codes may be stored in a memory (e.g., memory **230**, **272x** or **272y** in FIG. **2**) and executed by a processor (e.g., processor **232**, **270x** or **270y**). The memory may be implemented within the processor or external to the processor.

[0040] It should be noted that the concept of channels herein refers to information or transmission types that may be transmitted by the access point or access terminal. It does not require or utilize fixed or predetermined blocks of subcarriers, time periods, or other resources dedicated to such transmissions.

[0041] Referring to FIGS. **3A** and **3B**, aspects of superframe structures for a multiple access wireless communication system are illustrated. FIG. **3A** illustrates aspects of superframe structures for a frequency division duplexed (FDD) multiple access wireless communication system, while FIG. **3B** illustrates aspects of superframe structures for a time division duplexed (TDD) multiple access wireless communication system. The superframe preamble may be transmitted separately for each carrier or may span all of the carriers of the sector.

[0042] In both FIGS. **3A** and **3B**, the forward link transmission is divided into units of superframes. A superframe may consist of a superframe preamble followed by a series of frames. In an FDD system, the reverse link and the forward link transmission may occupy different frequency bandwidths so that transmissions on the links do not, or for the most part do not, overlap on any frequency subcarriers. In a TDD system, N forward link frames and M reverse link frames define the number of sequential forward link and reverse link frames that may be continuously transmitted prior to allowing transmission of the opposite type of frame. It should be noted that the number of N and M may vary within a given superframe or between superframes.

[0043] In both FDD and TDD systems each superframe may comprise a superframe preamble. In certain aspects, the superframe preamble includes a pilot channel that includes pilots that may be used for channel estimation by access terminals, a broadcast channel that includes configuration information that the access terminal may utilize to demodulate the information contained in the forward link frame. Further acquisition information such as timing and other information sufficient for an access terminal to communicate on one of the carriers and basic power control or offset information may also be included in the superframe preamble. In other cases, only some of the above and/or other information may be included in this superframe preamble.

[0044] As shown in FIGS. 3A and 3B, the superframe preamble is followed by a sequence of frames. Each frame may consist of a same or a different number of OFDM symbols, which may constitute a number of subcarriers that may simultaneously be utilized for transmission over some defined period. Further, each frame may operate according to a symbol rate hopping mode, where one or more non-contiguous OFDM symbols are assigned to a user on a forward link or reverse link, or a block hopping mode, where users hop within a block of OFDM symbols. The actual blocks or OFDM symbols may or may not hop between frames.

[0045] FIG. 4 illustrates communication between an access terminal 402 and an access network 404. The access network 404 sends a MCW-FLAB1 assignment block 408, with a set of supplemental fields, to the access terminal 402. Using a communication link 406 and based upon predetermined timing, system conditions, or other decision criteria, the access network 404 transmits the block 408 to the access terminal 402. The communication link may be implemented using communication protocols/standards such as World Interoperability for Microwave Access (WiMAX), infrared protocols such as Infrared Data Association (IrDA), short-range wireless protocols/technologies, Bluetooth® technology, ZigBee® protocol, ultra wide band (UWB) protocol, home radio frequency (HomeRF), shared wireless access protocol (SWAP), wideband technology such as a wireless Ethernet compatibility alliance (WECA), wireless fidelity alliance (Wi-Fi Alliance), 802.11 network technology, public switched telephone network technology, public heterogeneous communications network technology such as the Internet, private wireless communications network, land mobile radio network, code division multiple access (CDMA), wideband code division multiple access (WCDMA), universal mobile telecommunications system (UMTS), advanced mobile phone service (AMPS), time division multiple access (TDMA), frequency division multiple access (FDMA), orthogonal frequency division multiple (OFDM), orthogonal frequency division multiple access (OFDMA), orthogonal frequency division multiple FLASH (OFDM-FLASH), global system for mobile communications (GSM), single carrier (1X) radio transmission technology (RTT), evolution data only (EV-DO) technology, general packet radio service (GPRS), enhanced data GSM environment (EDGE), high speed downlink data packet access (HSPDA), analog and digital satellite systems, and any other technologies/protocols that may be used in at least one of a wireless communications network and a data communications network.

[0046] The access network 404 is configured to transmit block 408 to the access terminal 402. The access network 404 may incorporate the message 408 into a data packet or multiple data packets 412 which are transmitted on a forward link

406. In another aspect, the message 408 may be transmitted without being incorporated in to a packet. The data packets comprise header information that indicates whether the data packets 412 contain the MCW-FLAB1 block 408. The data packets 412 are exchanged on the forward link 406 using one or more channels. The access network 404 may also transmit a MCW-FLAB2 block to the access terminal along with the MCW-FLAB1 block. The access terminal 402 is configured to receive data packet 412 on the communication link 406, one of which may comprise the MCW-FLAB1 block 408.

[0047] Various methods may be used to extract the message 408 from the forward link at the access terminal 402. For example, once the access terminal 402 has extracted the data packets 412 from one of the channels of the forward link, it may check the header information of the data packets 412 to determine if the data packets 412 comprise the MCW-FLAB1 block 408. If so, then the access terminal 402 extracts the designated bits from the block 408 and stores the values in memory (such as memory 232 in FIG. 2). The access terminal 402 may, although this is not required, respond with an ACK or NACK message 410 over the communication link 406, and proceed to process the MCW-FLAB1 block based upon the value of supplemental field and whether a MCW-FLAB2 is also received. If the access terminal 402, receives the MCW-FLAB1 with its MACID from the SS MAC protocol with the supplemental field set to '0', then there may be a MCW-FLAB2 with its MACID received in the same PHY frame, otherwise, the access terminal 402 may ignore the MCW-FLAB1 message. If the access terminal 402 receives the MCW-FLAB1 with its MACID from the SS MAC protocol with the supplemental field set to '1', then if no MCW-FLAB2 with its MACID is received in the same PHY frame, the access terminal may use the current packet formats for layers 2 and above (provided there is an existing ATA of type MCWFLAB). Otherwise, if a MCW-FLAB2 with its MACID is received in the same PHY frame, the access terminal may update the packet formats for layer 2 and above according to the MCWFLAB2.

[0048] FIG. 5A illustrates a flow diagram of process 500, according to an embodiment. At 502, a MCW-FLAB1 is received at the access terminal. At 504, the value of supplemental field in the MCW-FLAB1 that has been received at the access terminal with its MACID from SS MAC protocol is determined. At 506, it is determined whether a MCW-FLAB2 is received with its MACID in the same PHY frame. At 508, the MCW-FLAB1 is processed based upon whether the MCW-FLAB2 is received with the MACID of the access terminal in the same PHY frame and based upon value of the supplemental field.

[0049] FIG. 5B illustrates a processor 550 for processing the MCW-FLAB1 block. The processors referred to may be electronic devices and may comprise one or more processors configured for processing MCW-FLAB1, according to the embodiment. A processor 552 is configured for receiving a MCW-FLAB1 at the access terminal. A processor 554 is configured for determining the value of supplemental field in the MCW-FLAB1 that has been received at the access terminal with its MACID from SS MAC protocol. Further, a processor 556 is configured for determining whether a MCW-FLAB2 is received with its MACID in the same PHY frame and a processor 558 is configured for processing the MCW-FLAB1 based upon whether the MCW-FLAB2 is received with the MACID of the access terminal in the same PHY frame and based upon value of the supplemental field. The

functionality of the discrete processors 552 to 558 depicted in the figure may be combined into a single processor 560. A memory 562 is also coupled to the processor 560.

[0050] In an embodiment, an apparatus is described which includes a means for receiving a MCW-FLAB1 at the access terminal. A means is provided for determining the value of supplemental field in the MCW-FLAB1 that has been received at the access terminal with its MACID from SS MAC protocol. Further, a means is provided for determining whether a MCW-FLAB2 is received with its MACID in the same PHY frame and a means is provided for processing the MCW-FLAB1 based upon whether the MCW-FLAB2 is received with the MACID of the access terminal in the same PHY frame and based upon value of the supplemental field. The means described herein may comprise one or more processors.

[0051] Furthermore, embodiments may be implemented by hardware, software, firmware, middleware, microcode, or any combination thereof. When implemented in software, firmware, middleware or microcode, the program code or code segments to perform the necessary tasks may be stored in a machine readable medium such as a separate storage(s) not shown. A processor may perform the necessary tasks. A code segment may represent a procedure, a function, a sub-program, a program, a routine, a subroutine, a module, a software package, a class, or any combination of instructions, data structures, or program statements. A code segment may be coupled to another code segment or a hardware circuit by passing and/or receiving information, data, arguments, parameters, or memory contents. Information, arguments, parameters, data, etc. may be passed, forwarded, or transmitted via any suitable means including memory sharing, message passing, token passing, network transmission, etc.

[0052] Various modifications to these aspects will be readily apparent to those skilled in the art, and the generic principles defined herein may be applied to other aspects. Thus, the description is not intended to be limited to the aspects shown herein but is to be accorded the widest scope consistent with the principles and novel features disclosed herein.

We claim:

1. A method for processing a Multi-code word assignment in a wireless communication system, characterized in that:
 - receiving a Multi Code Word Forward Link Assignment Block 1 (MCW-FLAB1);
 - determining value of supplemental field in the MCW-FLAB1 received with a MACID of an access terminal from the Shared Signaling Medium Access Control (SS MAC) protocol with a supplemental field;
 - determining whether a Multi Code Word Forward Link Assignment Block 2 (MCW-FLAB2) is received with MACID in a same Physical layer (PHY) frame; and
 - processing the MCW-FLAB1 based upon whether the MCW-FLAB2 is received and the value of the supplemental field.
2. The method as claimed in claim 1, characterized in that processing comprises ignoring the MCW-FLAB1, if a MCW-FLAB2 with the MACID for the access terminal in the same PHY channel is not received and the supplemental field value is set to '0'.
3. The method as claimed in claim 1, characterized in that processing comprises using the MCW-FLAB1 and the MCW-FLAB2, if the MCW-FLAB2 with the MACID for the

access terminal in the same PHY channel is received and the supplemental field value is set to '0'.

4. The method as claimed in claim 1, characterized in that processing comprises updating packet formats for layer 2 and above according to MCW-FLAB2, if supplemental field value is set to '1'.

5. The method as claimed in 1, characterized in that processing comprises using the current packet format for layer 2 and above, provided there is an existing assignment of type MCWFLAB if the MCW-FLAB2 with the MACID for the access terminal in the same PHY frame is not received and the supplemental field value is set to '1'.

6. A computer-readable medium including instructions stored thereon, characterized in that:

- a first set of instructions for receiving a Multi Code Word Forward Link Assignment Block 1 (MCW-FLAB1);
- a second set of instructions for determining value of supplemental field in the MCW-FLAB1 received with a MACID of an access terminal from the Shared Signaling Medium Access Control (SS MAC) protocol with a supplemental field;
- a third set of instructions for determining whether a Multi Code Word Forward Link Assignment Block 2 (MCW-FLAB2) is received with MACID in a same Physical layer (PHY) frame; and
- a fourth set of instructions for processing the MCW-FLAB1 based upon whether the MCW-FLAB2 is received and the value of the supplemental field.

7. The computer-readable medium as claimed in claim 6, characterized in that a fifth set of instructions for ignoring the MCW-FLAB1 if a MCW-FLAB2 with the MACID for the access terminal in the same PHY channel is not received and the supplemental field value is set to '0'.

8. The computer-readable medium as claimed in claim 6, characterized in that a sixth set of instructions for using the MCW-FLAB1 and the MCW-FLAB2, if the MCW-FLAB2 with the MACID for the access terminal in the same PHY channel is received and the supplemental field value is set to '0'.

9. The computer-readable medium as claimed in claim 6, characterized in that a seventh set of instructions for updating packet formats for layer 2 and above according to MCW-FLAB2, if supplemental field value is set to '1'.

10. The computer-readable medium as claimed in claim 6, characterized in that an eighth set of instructions for using the current packet format for layer 2 and above, provided there is an existing assignment of type MCWFLAB if the MCW-FLAB2 with the MACID for the access terminal in the same PHY frame is not received and the supplemental field value is set to '1'.

11. An apparatus operable in a wireless communication system, characterized in that:

- means for receiving a Multi Code Word Forward Link Assignment Block 1 (MCW-FLAB1);
- means for determining value of supplemental field in the MCW-FLAB1 received with a MACID of an access terminal from the Shared Signaling Medium Access Control (SS MAC) protocol with a supplemental field;
- means for determining whether a Multi Code Word Forward Link Assignment Block 2 (MCW-FLAB2) is received with MACID in a same Physical layer (PHY) frame; and

means for processing the MCW-FLAB1 based upon whether the MCW-FLAB2 is received and the value of the supplemental field.

12. The apparatus as claimed in claim **11**, characterized in that having means for ignoring the MCW-FLAB1, if a MCW-FLAB2 with the MACID for the access terminal in the same PHY channel is not received and the supplemental field value is set to '0'.

13. The apparatus as claimed in claim **11**, characterized in that having means for using the MCW-FLAB1 and the MCW-FLAB2, if the MCW-FLAB2 with the MACID for the access terminal in the same PHY channel is received and the supplemental field value is set to '0'.

14. The apparatus as claimed in claim **11**, characterized in that having means for updating packet formats for layer **2** and above according to MCW-FLAB2, if supplemental field value is set to '1'.

15. The apparatus as claimed in claim **11**, characterized in that having means for using the current packet format for layer **2** and above, provided there is an existing assignment of type MCWFLAB if the MCW-FLAB2 with the MACID for the access terminal in the same PHY frame is not received and the supplemental field value is set to '1'.

* * * * *