



INTERNATIONAL APPLICATION PUBLISHED UNDER THE PATENT COOPERATION TREATY (PCT)

<p>(51) International Patent Classification ⁶ : G01N 27/22, 27/02, 33/487, 33/49</p>	<p>A1</p>	<p>(11) International Publication Number: WO 97/39343 (43) International Publication Date: 23 October 1997 (23.10.97)</p>
<p>(21) International Application Number: PCT/GB97/01073 (22) International Filing Date: 17 April 1997 (17.04.97) (30) Priority Data: 9607898.5 17 April 1996 (17.04.96) GB (71) Applicant (for all designated States except US): BRITISH NUCLEAR FUELS PLC [GB/GB]; Risley, Warrington, Cheshire WA3 6AS (GB). (72) Inventors; and (75) Inventors/Applicants (for US only): GARNHAM, Geoffrey, William [GB/GB]; British Nuclear Fuels plc, Research and Technology, B516, Springfields Works, Salwick, Preston, Lancashire PR4 0XJ (GB). MORE, Brian, Robert [GB/GB]; British Nuclear Fuels plc, Research and Technology, B516, Springfields Works, Salwick, Preston, Lancashire PR4 0XJ (GB). BONE, Stephen [GB/GB]; Bangor University, School of Electronic Engineering, Bangor, Gwynedd LL57 1UT (GB). JAFFARI, Samrah [GB/GB]; Bangor University, School of Electronic Engineering, Bangor, Gwynedd LL57 1UT (GB). (74) Agent: PAWLYN, Anthony, Neil; Urquhart-Dykes & Lord, Tower House, Merrion Way, Leeds LS2 8PA (GB).</p>		<p>(81) Designated States: AL, AM, AT, AU, AZ, BA, BB, BG, BR, BY, CA, CH, CN, CU, CZ, DE, DK, EE, ES, FI, GB, GE, GH, HU, IL, IS, JP, KE, KG, KP, KR, KZ, LC, LK, LR, LS, LT, LU, LV, MD, MG, MK, MN, MW, MX, NO, NZ, PL, PT, RO, RU, SD, SE, SG, SI, SK, TJ, TM, TR, TT, UA, UG, US, UZ, VN, YU, ARIPO patent (GH, KE, LS, MW, SD, SZ, UG), Eurasian patent (AM, AZ, BY, KG, KZ, MD, RU, TJ, TM), European patent (AT, BE, CH, DE, DK, ES, FI, FR, GB, GR, IE, IT, LU, MC, NL, PT, SE), OAPI patent (BF, BJ, CF, CG, CI, CM, GA, GN, ML, MR, NE, SN, TD, TG).</p> <p>Published <i>With international search report. Before the expiration of the time limit for amending the claims and to be republished in the event of the receipt of amendments.</i></p>

(54) Title: BIOSENSORS

(57) Abstract

Apparatus and methods are provided for determining capacitance and/or conductance variation of a biosensor on contact with a component with which the biological agent of the sensor interacts. A variety of AC frequencies may be applied to make the measurements. The biological agent is ideally isolated from the sensor/electrolyte interface double layer.

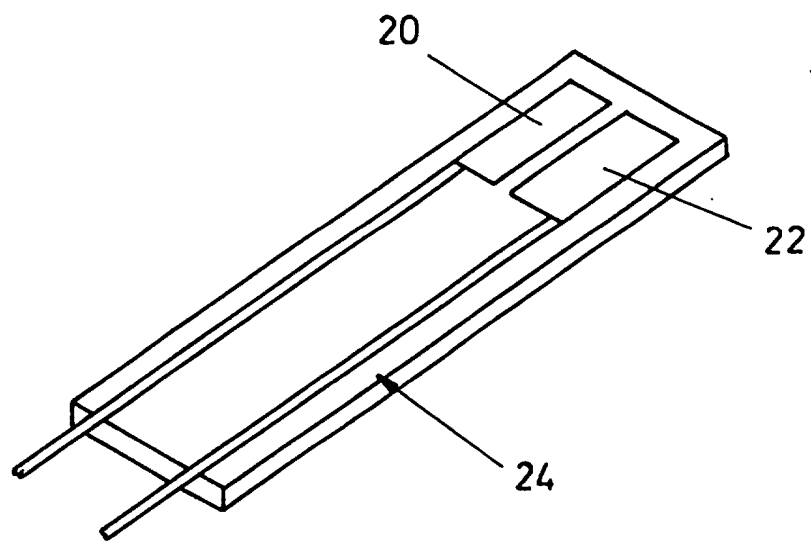

FOR THE PURPOSES OF INFORMATION ONLY

Codes used to identify States party to the PCT on the front pages of pamphlets publishing international applications under the PCT.

AL	Albania	ES	Spain	LS	Lesotho	SI	Slovenia
AM	Armenia	FI	Finland	LT	Lithuania	SK	Slovakia
AT	Austria	FR	France	LU	Luxembourg	SN	Senegal
AU	Australia	GA	Gabon	LV	Latvia	SZ	Swaziland
AZ	Azerbaijan	GB	United Kingdom	MC	Monaco	TD	Chad
BA	Bosnia and Herzegovina	GE	Georgia	MD	Republic of Moldova	TG	Togo
BB	Barbados	GH	Ghana	MG	Madagascar	TJ	Tajikistan
BE	Belgium	GN	Guinea	MK	The former Yugoslav Republic of Macedonia	TM	Turkmenistan
BF	Burkina Faso	GR	Greece			TR	Turkey
BG	Bulgaria	HU	Hungary	ML	Mali	TT	Trinidad and Tobago
BJ	Benin	IE	Ireland	MN	Mongolia	UA	Ukraine
BR	Brazil	IL	Israel	MR	Mauritania	UG	Uganda
BY	Belarus	IS	Iceland	MW	Malawi	US	United States of America
CA	Canada	IT	Italy	MX	Mexico	UZ	Uzbekistan
CF	Central African Republic	JP	Japan	NE	Niger	VN	Viet Nam
CG	Congo	KE	Kenya	NL	Netherlands	YU	Yugoslavia
CH	Switzerland	KG	Kyrgyzstan	NO	Norway	ZW	Zimbabwe
CI	Côte d'Ivoire	KP	Democratic People's Republic of Korea	NZ	New Zealand		
CM	Cameroon			PL	Poland		
CN	China	KR	Republic of Korea	PT	Portugal		
CU	Cuba	KZ	Kazakstan	RO	Romania		
CZ	Czech Republic	LC	Saint Lucia	RU	Russian Federation		
DE	Germany	LI	Liechtenstein	SD	Sudan		
DK	Denmark	LK	Sri Lanka	SE	Sweden		
EE	Estonia	LR	Liberia	SG	Singapore		

BIOSENSORS

This invention concerns improvements in and relating to sensors, and in particular biosensors.

Biosensors are known in which an enzyme or other biological agent is provided in association with an electrode circuit. The variation in properties of the enzyme as it reacts or interacts with a substrate present in the material brought into contact with the enzyme gives rise to physical changes which can be monitored. Biosensors have principally relied to date upon a potential or current being produced by the reaction, an oxidation or reduction, which can be measured for the system. In this way a measurement of the substrate content in the material to which the biosensor is introduced can be determined. Biosensors of this type for instance find application in the glucose oxidase system for detecting glucose in blood samples.

The present invention is concerned with a system in which a fundamentally different and previously unused property of the biosensor is determined.

According to a first aspect of the invention we provide a sensor comprising a first and second electrode, both electrodes being provided with a polymeric material and a biological agent, the biological agent catalysing a reaction between a component, which may or not be present, in a material to be tested, the first and second electrodes being electrically connected to one another via control means, the control means applying an AC voltage at a given frequency to the electrodes in use, the circuit also providing means for measuring the conductance and / or capacitance of the electrodes.

The use of conductance and / or capacitance, as opposed to current or voltage production, to measure the presence of a component in a material to be tested is advantageous in terms of the sensitivity and selectivity resulting.

Preferably the biological agent is an enzyme. The provision of antigens, whole cells and proteins in general as

-2-

the biological agent is envisaged. Reference to enzymes includes these alternative biological agents.

It is particularly preferred that the enzyme be completely or at least highly specific for the component in question. The biological agent may directly or indirectly interact with the component in a reactive or catalytic manner.

The polymeric material is preferably inert and / or insulating. Cellulose plastics materials are preferred polymers, with cellulose acetate being particularly preferred. The polymeric material may be a gel, such as gelatine. Mixtures of materials, polymers or gels may be used.

The enzyme may be an appropriate enzyme to the glucose system, such as glucose oxidase. Enzymes such as SH enzymes, ie urease, asparaginase, aswell as enzymes for the creatine system or the creatinine system or the nitrate / nitrite system can be used.

The enzyme may be immobilized within the polymer matrix, preferably in an hydrated state or between the polymer and electrode. Preferably the biological agent is separated, isolated or discretely positioned relative to the double layer. The double layer being present at the polymer to electrolyte interface. By providing the enzyme "bound in" or "isolated" in this way stability and immunity to degradation is improved over prior art systems.

Preferably the enzyme is cross linked to the polymeric material. Glutraldehyde is a particularly preferred cross linking agent.

The polymeric material may be bound to a metallic electrode. Platinum, gold and copper offer suitable such electrode materials. Carbon may also be suitable. The first and second electrode may be provided in opposing relationship, that is facing one another, or may be provided alongside each other, for instance on a planar surface. Provision as an interdigitated array is also envisaged. Both first and second electrodes may be the same in properties and structure. In some circumstances a differential electrode configuration

employing a non-enzyme coated electrode as a reference may be employed.

The applied frequency is preferably between 1 Hz and 100 MHz or 10 Hz to 10 MHz or more preferably between 1 kHz and 300 kHz. Frequencies in the range 5 kHz to 200 kHz have been found particularly suitable. Preferably an applied frequency greater than 10kHz is used. Measurements conducted at such conditions are particularly sensitive to the effect of the biological agent and independent of the double layer and electrolyte conditions or electrode phenomena.

The conductance and / or capacitance is preferably measured using an AC bridge, or any other instrumentation for the measurement of AC conductance and / or capacitance.

Preferably the material, which may or may not contain the component to be detected, is a liquid. Aqueous based electrolytes are envisaged as the material. The application of the sensor in effluent and / or medical applications in particular is considered. The sensor may be used for immunological assays, detecting dissolved species, such as metal ions or organic materials or the like.

According to a second aspect of the invention we provide a method for determining the presence of a component in a material comprising contacting the material with a first and second electrode, both electrodes being provided with a polymeric material and biological agent, preferably an enzyme, which is catalytic to or interacts with a component to be detected, the first and second electrodes being in electrical contact with one another and with control means, the control means being used to apply an AC voltage at a given frequency to the system and measuring the conductance and / or capacitance.

The method may comprise the application of a voltage at a given or substantially constant frequency. Alternatively a number of different frequencies may be applied over a period of time.

The material to be tested may be introduced between the electrodes. In a preferred form the electrolyte may be positioned so as to bridge the gap between the first and second

-4-

electrodes with the first and second electrodes in a substantially common plane.

One or more different enzymes may be present in the polymeric material, such as a gel, or between the polymeric material and electrode. Two or more first electrodes may be provided. Each may incorporate or be provided with a different enzyme or enzymes.

The applied frequency to each first electrode may be optimised to that of the particular enzyme and / or the envisaged electrolyte.

Various embodiments of the invention and its operation will now be described, by way of example only, and with reference to the accompanying drawings in which:-

Figure 1 illustrates an exploded view of a test cell assembly;

Figure 2 illustrates conductance against frequency measurements for glucose at varying concentrations;

Figure 3 illustrates a calibration plot for a cross linked glucose sensor and response to a comparable sugar, sucrose; and

Figure 4 illustrates a biosensor according to a second embodiment.

The test cell illustrated in Figure 1 comprises a pair of planar copper electrodes (2, 4) which are electrically connected to one another via suitable connections (5) and control electronics, shown schematically (6). Each electrode (2, 4) carries an identical coating with the coating mounted on the opposing faces (3, 5) of the electrodes.

The electrodes are formed of copper and are coated with cellulose acetate as the polymer. The polymer layer incorporates a glucose oxidase layer cross linked with gluteraldehyde.

The test chamber to which the electrolyte to be measured can be introduced is formed by a hollow perspex housing (8) provided with an inlet (10). The housing (8) is sealed by

means of rubber "O" rings (12) contacting the electrodes (2, 4).

The electronic controls (6) comprise an AC component analyser and a 486 dx PC. The AC component analyser (frequency range of 10 Hz to 1 MHz) was used to measure the complex admittance of the polymer / enzyme modified electrode / electrolyte system. The AC voltage signals over the specified frequency range from the component analyser (1V peak to peak) were applied to the cell and capacitance and conductance data were collected via a GPIB card interface and a 468dx P.C.

For the purposes of the test procedures the electrolyte was introduced as a 10 mM phosphate buffer system at pH 7 in conjunction with varying concentrations of the substrate to be monitored.

The test compared the substrate concentrations in the electrolyte by studying the variance in conductance with substrate concentration over a wide frequency range.

Such results from known electrolytes can be used to determine unknown substrate levels.

Monitoring in this way is possible because it has been found that a polymer film coating a suitable system and in contact with the electrolyte gives conductance measurements which are solely sensitive to the polymer film itself and not to the aqueous phase. If the polymer is present as an inert, isolating material the enzyme / substrate interaction becomes the variable. Thus the measurement is indicative of the original substrate concentration independent of the many other complex variables within the electrolyte system.

The conductance measurements for such a given system vary over the frequency range. Variations in the structure of the bound component and enzyme are believed responsible.

Figure 2 illustrates a series of tests performed over a variety of frequencies on a series of electrolyte samples containing varying known concentrations of glucose. Standard initial buffer response was also undertaken to enable accurate calibration of the system.

-6-

As can be seen from the comparison of the initial buffer response and buffer response following the series of tests the biosensor is highly stable and relatively immune to degradation exhibited by enzymes in prior art systems. The conductance shifts are believed to arise from variations in gluconic acid production.

Figure 3 provides a typical calibration plot for a chemically cross-linked glucose sensor according to the invention and also illustrates the relatively negligible response to a comparable sugar, sucrose, indicating the specificity of the invention.

In an easily used and potentially disposable sensor employing this invention, as illustrated in Figure 4 the electrodes (20, 22) are provided on a planar base (24) in close proximity to each other. Thus only a very small sample of the electrolyte needs to be placed on the sensor for a result to be achieved. This could for instance represent a drop of blood from a patient whose blood glucose level is to be determined.

In this embodiment the control electronics (not shown) apply a single predetermined frequency to the electrodes. This predetermined frequency is selected for the system in question so as to give the best delineation in concentration and / or response time.

Whilst the biosensor has been discussed above in relation to a cellulose acetate polymer many other suitable polymers exist, the requirements of them solely being that they are inert in the system of interest and electrically insulating.

Equally, the provision of enzymes for other substrates eg creatine, creatinine, nitrate / nitrite and / or the provision of antigen based biosensors is envisaged. Biosensors for use in medical and environmental monitoring uses are envisaged.

The biosensing technique discussed above based on conductance as a means of monitoring provides biosensors offering a high degree of measurement sensitivity, fast response times and systems which are highly stable compared with hydrated state enzyme systems. Additionally, the potential for conducting the measurements at a wide range of

-7-

electrical frequencies so as to tailor the system to the enzyme and electrolyte under consideration offers enhanced flexibility.

CLAIMS:

1. A sensor comprising a first and second electrode, both electrodes being provided with a polymeric material and a biological agent, the biological agent catalysing a reaction between a component, which may or not be present, in a material to be tested, the first and second electrodes being electrically connected to one another via control means, the control means applying an AC voltage at a given frequency to the electrodes in use, the circuit also providing means for measuring the conductance and / or capacitance of the electrodes.

2. A sensor according to claim 1 in which the biological agent is isolated from the sensor/material interface double layer.

3. A sensor according to claim 1 or claim 2 in which the biological component is an enzyme or several enzymes.

4. A sensor according to any of claims 1 to 3 in which the applied frequency is between 1 Hz and 10 MHz.

5. A sensor according to any preceding claim in which the frequency is in the range 5 kHz to 200 kHz.

6. A sensor according to any preceding claim in which the conductance and / or capacitance is measured using an AC bridge.

7. A sensor according to any preceding claim in which the polymeric material is inert and insulating.

8. A sensor according to any preceding claim in which cellulose plastics materials are employed.

9. A sensor according to any of claims 1 to 7 in which the polymeric material is a gel, such as gelatine.

10. A sensor according to any preceding claim in which the enzyme is cross linked to the polymeric material.

11. A sensor according to claim 10 in which gluteraldehyde is the cross linking agent.

12. A sensor according to any preceding claim in which the enzyme is immobilised within the polymer matrix or between the polymer and electrode.

13. A method for determining the presence of a component in a material comprising contacting the material with a first and second electrode, both electrodes providing a polymeric material and biological agent which is catalytic to or interacts with a component to be detected, the first and second electrodes being in electrical contact with another and control means being used to apply an AC voltage at a given frequency to the system and measuring the conductance and / or capacitance.

14. A method according to claim 13 comprising the application of a voltage at a given or substantially constant single frequency.

15. A method according to claim 13 in which a number of different frequencies are applied over a period of time.

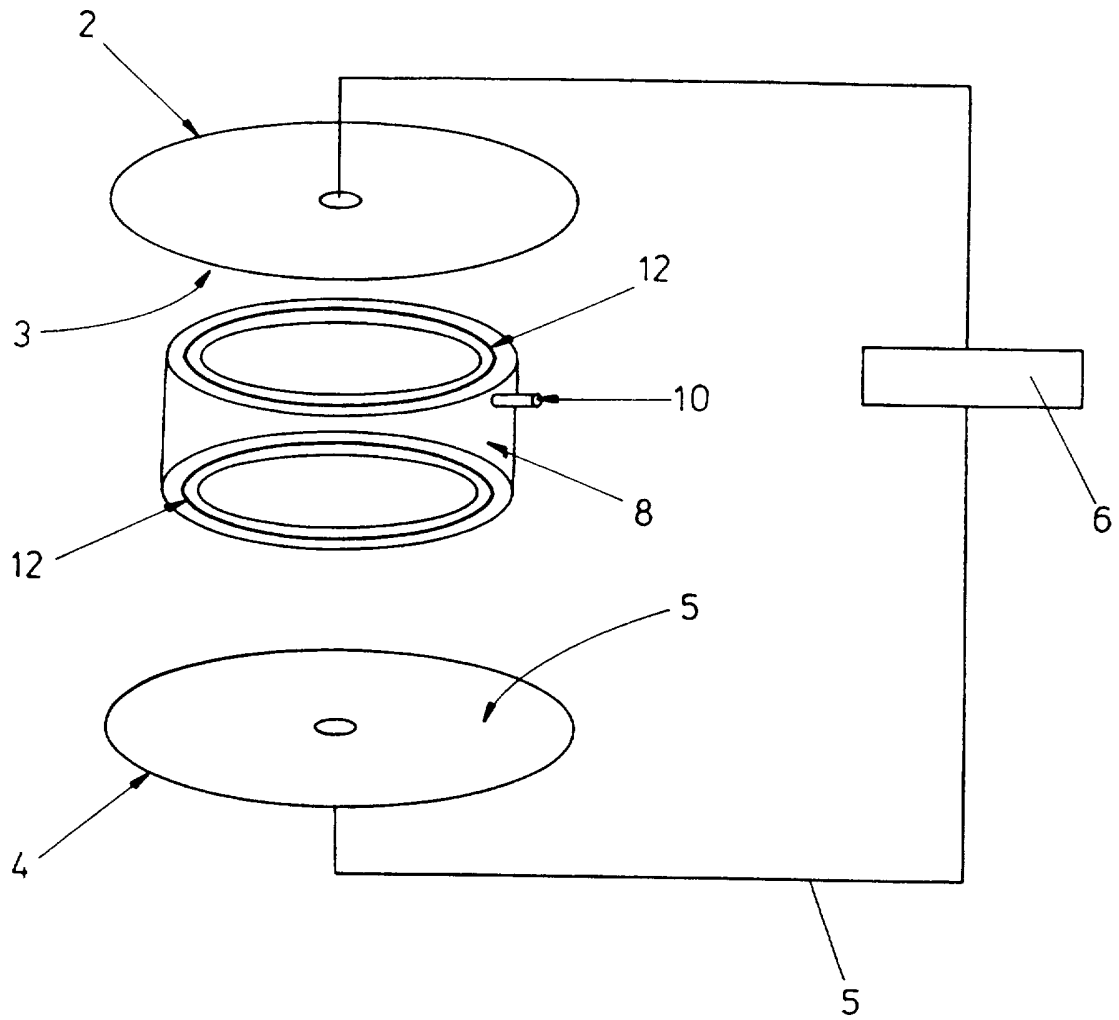

FIG. 1

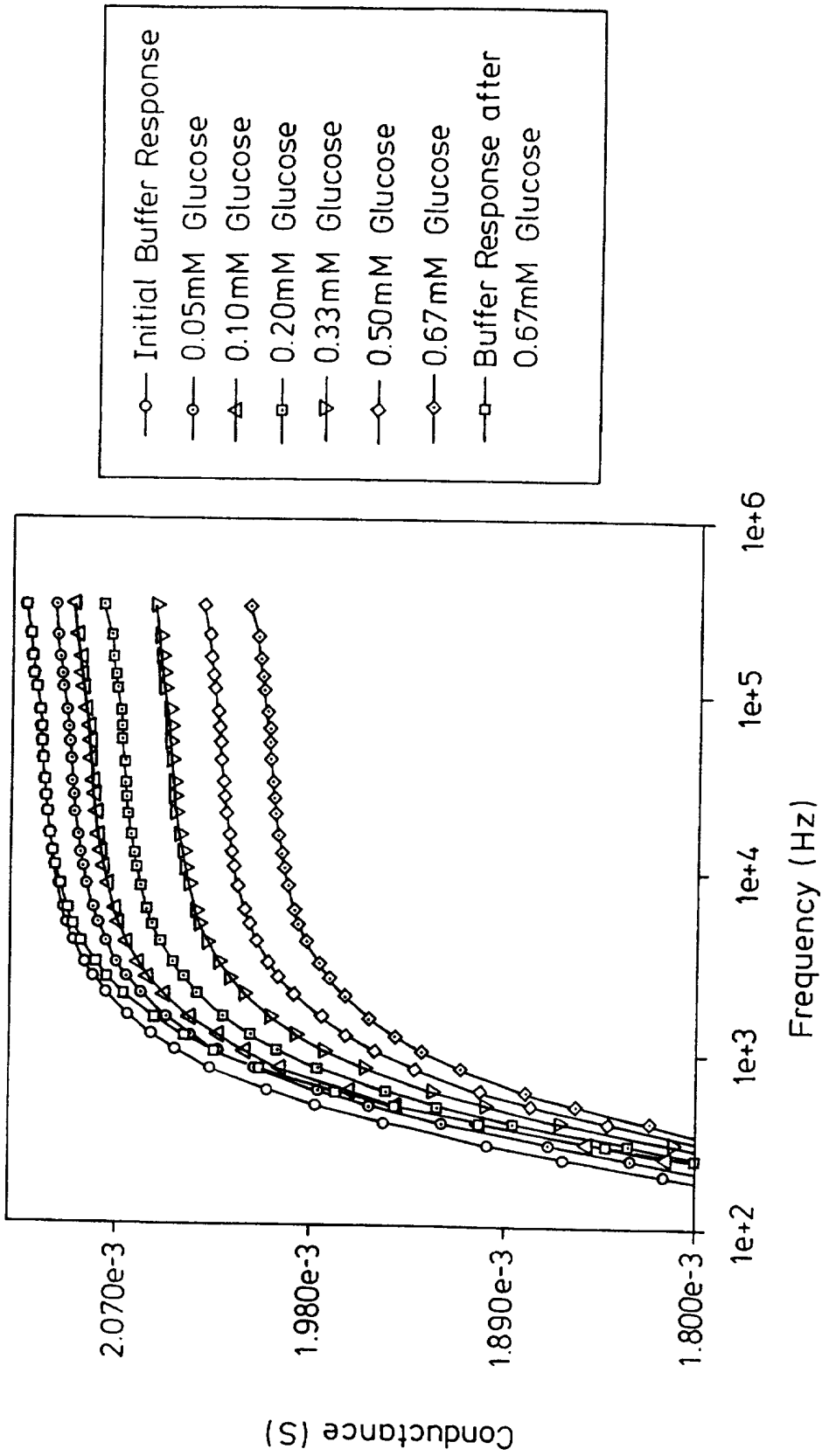

FIG. 2

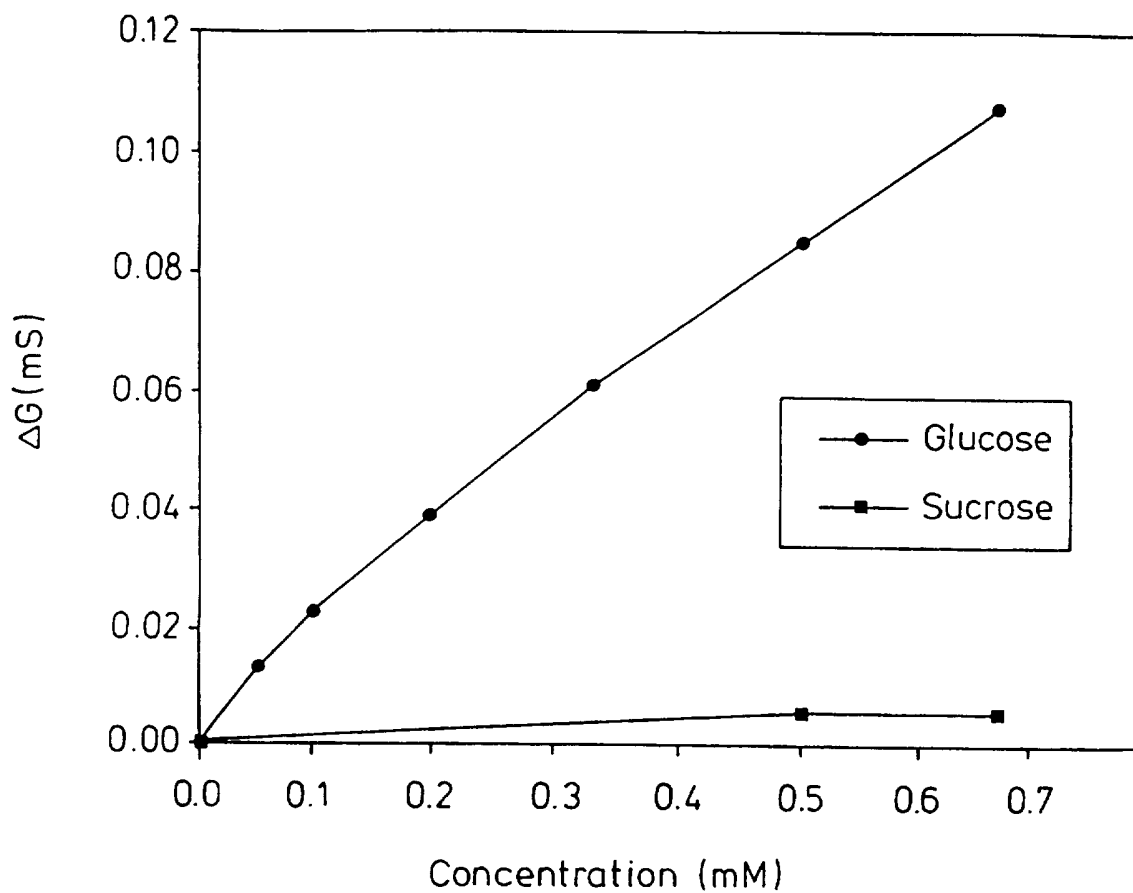

FIG. 3

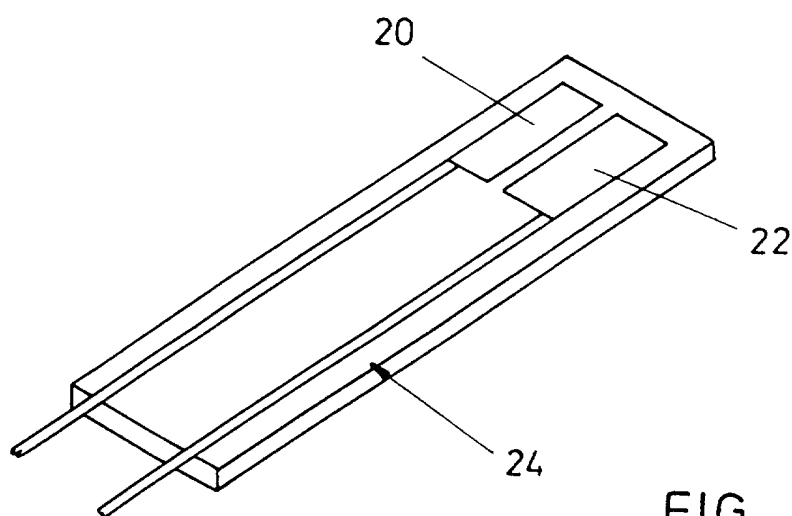

FIG. 4

INTERNATIONAL SEARCH REPORT

Internat. Application No

PCT/GB 97/01073

A. CLASSIFICATION OF SUBJECT MATTER
 IPC 6 G01N27/22 G01N27/02 G01N33/487 G01N33/49

According to International Patent Classification (IPC) or to both national classification and IPC

B. FIELDS SEARCHED

Minimum documentation searched (classification system followed by classification symbols)

IPC 6 G01N

Documentation searched other than minimum documentation to the extent that such documents are included in the fields searched

Electronic data base consulted during the international search (name of data base and, where practical, search terms used)

C. DOCUMENTS CONSIDERED TO BE RELEVANT

Category *	Citation of document, with indication, where appropriate, of the relevant passages	Relevant to claim No.
X	WO 88 08541 A (BIOTRONIC SYSTEMS CORPORATION) 3 November 1988	1-7, 12-15
Y	see the whole document ---	9
X	WO 87 03095 A (THE JOHNS HOPKINS UNIVERSITY/APPLIED PHYSICS LABORATORY) 21 May 1987 see the whole document ---	1-7, 12-15
Y	EP 0 634 488 A (GOLDSTAR CO., LTD.) 18 January 1995 see the whole document ---	9
A	WO 96 04398 A (MEDISENSE INC.) 15 February 1996 see the whole document ---	1-15
	-/--	

Further documents are listed in the continuation of box C.

Patent family members are listed in annex.

* Special categories of cited documents :

- *A* document defining the general state of the art which is not considered to be of particular relevance
- *E* earlier document but published on or after the international filing date
- *L* document which may throw doubts on priority claim(s) or which is cited to establish the publication date of another citation or other special reason (as specified)
- *O* document referring to an oral disclosure, use, exhibition or other means
- *P* document published prior to the international filing date but later than the priority date claimed

- *T* later document published after the international filing date or priority date and not in conflict with the application but cited to understand the principle or theory underlying the invention
- *X* document of particular relevance; the claimed invention cannot be considered novel or cannot be considered to involve an inventive step when the document is taken alone
- *Y* document of particular relevance; the claimed invention cannot be considered to involve an inventive step when the document is combined with one or more other such documents, such combination being obvious to a person skilled in the art.
- *&* document member of the same patent family

Date of the actual completion of the international search

19 August 1997

Date of mailing of the international search report

27.08.97

Name and mailing address of the ISA

European Patent Office, P.B. 5818 Patentlaan 2
 NL - 2280 HV Rijswijk
 Tel. (+ 31-70) 340-2040, Tx. 31 651 epo nl,
 Fax (+ 31-70) 340-3016

Authorized officer

Bosma, R

INTERNATIONAL SEARCH REPORT

Internat Application No
PCT/GB 97/01073

C.(Continuation) DOCUMENTS CONSIDERED TO BE RELEVANT		
Category *	Citation of document, with indication, where appropriate, of the relevant passages	Relevant to claim No.
A	PATENT ABSTRACTS OF JAPAN vol. 18, no. 349 (P-1763), 30 June 1994 & JP 06 008806 A (FUJITSU LTD), 29 March 1994, see abstract <p style="text-align: center;">-----</p>	1-15

1

INTERNATIONAL SEARCH REPORT

Information on patent family members

International Application No
PCT/GB 97/01073

Patent document cited in search report	Publication date	Patent family member(s)	Publication date
WO 8808541 A	03-11-88	US 5082627 A	21-01-92
WO 8703095 A	21-05-87	CA 1259374 A	12-09-89
		EP 0245477 A	19-11-87
		JP 63501446 T	02-06-88
		US 4822566 A	18-04-89
EP 634488 A	18-01-95	KR 9701146 B	29-01-97
		JP 7077511 A	20-03-95
WO 9604398 A	15-02-96	AU 3182395 A	04-03-96
		CA 2196380 A	15-02-96
		EP 0775214 A	28-05-97