



US 20030136420A1

(19) **United States**

(12) **Patent Application Publication**
Kraker

(10) **Pub. No.: US 2003/0136420 A1**

(43) **Pub. Date: Jul. 24, 2003**

(54) **SMOKING ARTICLES WITH REDUCED
IGNITION PROCLIVITY
CHARACTERISTICS**

Publication Classification

(51) **Int. Cl.⁷** **A24B 1/00**
(52) **U.S. Cl.** **131/360; 131/365**

(75) **Inventor: Thomas A. Kraker, Alpharetta, GA
(US)**

(57) **ABSTRACT**

Correspondence Address:
Timothy A. Cassidy, Esq.
Dority & Manning
Attorneys at Law, P.A.
P.O. Box 1449
Greenville, SC 29602 (US)

A process for reducing the permeability of a paper wrapper used in the construction of a smoking article is disclosed. The paper wrapper is treated with a film-forming composition that forms treated discrete areas on the wrapper. The treated discrete areas have a permeability within a predetermined range sufficient to reduce the ignition proclivity properties of a smoking article made with the wrapper. In accordance with the present invention, the film-forming composition contains a film-forming material. The film-forming material has a relatively low viscosity. In this manner, the film-forming composition can have a relatively high solids content and still be applied to the wrapper using conventional techniques, such as by using a gravure printer.

(73) **Assignee: Schweitzer-Mauduit International, Inc.**

(21) **Appl. No.: 10/055,027**

(22) **Filed: Jan. 23, 2002**

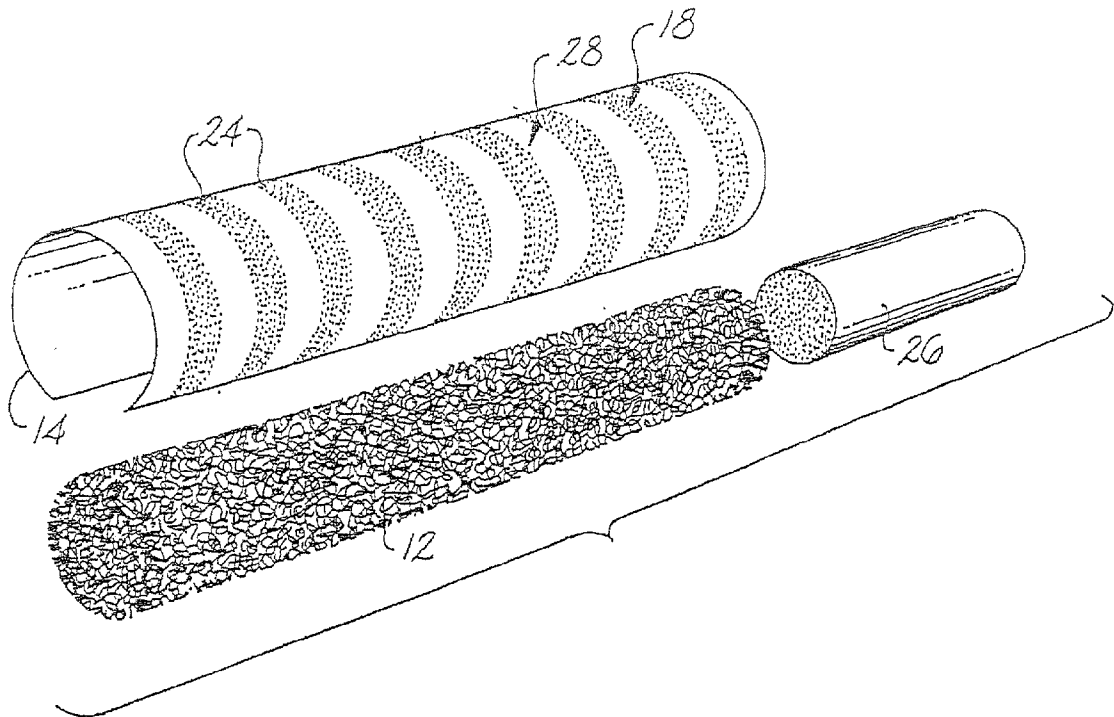

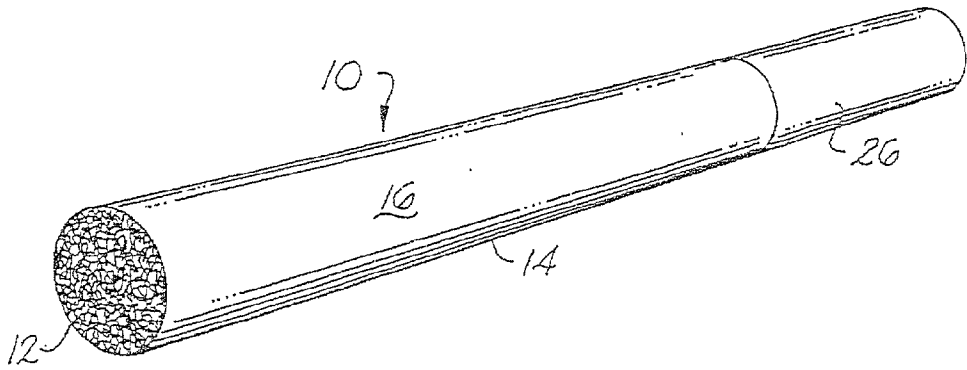

Fig. 1

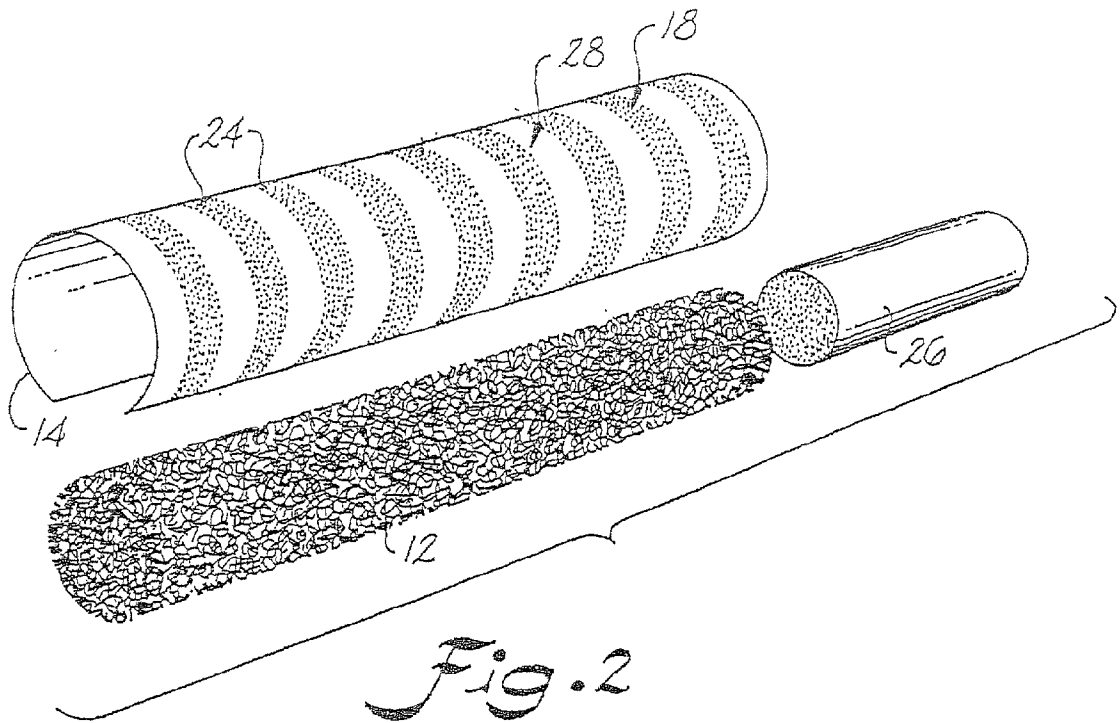

Fig. 2

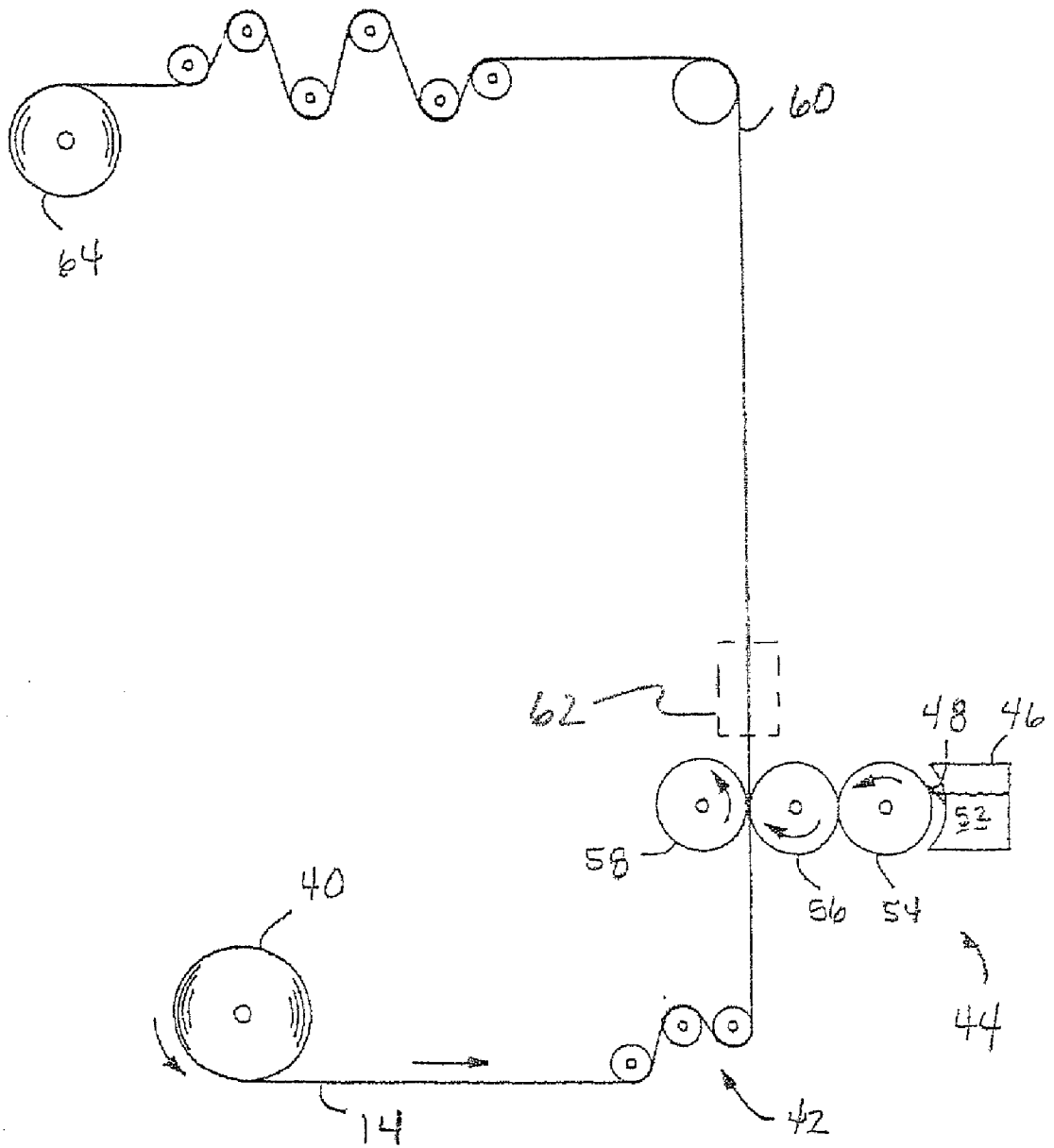

Fig. 3

SMOKING ARTICLES WITH REDUCED IGNITION PROCLIVITY CHARACTERISTICS

BACKGROUND OF THE INVENTION

[0001] There is an ongoing concern in the tobacco industry to produce cigarettes having wrappers which reduce the ignition proclivity of the smoking article, or the tendency of the smoking article to ignite surfaces which come into contact with the lit smoking article. Reports have been made of fires attributed to burning cigarettes coming into contact with combustible materials. A justifiable interest exists in the industry to reduce the tendency of cigarettes, or other smoking articles to ignite surfaces and materials used in furniture, bedding, and the like upon contact.

[0002] Thus, a desirable feature of smoking articles, particularly cigarettes, is that they self-extinguish upon being dropped or left in a free burning state on combustible materials.

[0003] It has long been recognized in the tobacco industry that the cigarette wrapper has a significant influence on the smolder characteristics of the cigarette. In this regard, various attempts have been made in the art to alter or modify the cigarette wrappers in order to achieve the desired tendency of the cigarette to self-extinguish, or in other words to reduce the ignition proclivity characteristics of cigarettes.

[0004] The prior art describes the application of film-forming solutions to cigarette paper to reduce the paper permeability and control the burn rate. It has been shown that when these materials have been applied in discrete areas along the length of the cigarette, the cigarette shows a reduced propensity to ignite a substrate, tends to self-extinguish, and has a higher puff count.

[0005] U.S. Pat. No. 5,878,753 to Peterson and U.S. Pat. No. 5,820,998 to Hotaling, et al. which are incorporated herein by reference, U.S. Pat. No. 5,820,998 to Hotaling, et al. which are incorporated herein by reference, for example, describe a smoking article wrapper being treated with a film-forming aqueous solution to reduce permeability. U.S. Pat. No. 5,878,754 to Peterson which is also incorporated herein by reference describes a smoking article wrapper being treated with a non-aqueous solution of a solvent soluble polymer dissolved in a non-aqueous solution to reduce permeability.

[0006] Although some improvements have been made in the art, there is still a need for an improved method for producing a cigarette wrapper with reduced ignition proclivity properties. Specifically, a need exists for an improved method of applying a film-forming solution to a paper wrapper in discrete areas for decreasing the permeability of the wrapper down to a desired range, especially when the wrapper has an initially high porosity.

SUMMARY OF THE INVENTION

[0007] The present invention is generally directed to paper wrappers for smoking articles with reduced ignition proclivity and to a process for making the wrappers. For example, in one embodiment, the process includes the steps of providing a paper wrapper made from a paper web. For example, the paper wrapper can contain flax fibers, softwood fibers, hardwood fibers and mixtures thereof. The paper

wrapper can also include a filler, such as calcium carbonate, in an amount from about 10% to about 40% by weight.

[0008] A film-forming composition is applied to the paper wrapper at particular locations. The multiple layers of the film-forming composition form treated discrete areas on the wrapper. The discrete areas are separated by untreated areas. The treated discrete areas have a permeability within a predetermined range sufficient to reduce ignition proclivity. For example, the treated areas can reduce ignition proclivity by reducing oxygen to a smoldering coal of the smoking article as the coal burns and advances into the treated areas.

[0009] In accordance with the present invention, the film-forming composition contains a film-forming material. The film-forming material has a relatively low viscosity which typically indicates a lower molecular weight. By using a film-forming material having a relatively low viscosity, the film-forming composition can have a higher solids content and yet have a solution viscosity capable of being used in conventional application techniques, such as being used in a gravure printing process.

[0010] For example, the film forming material contained within the composition can have a viscosity of less than about 500 cP when present in a 3% aqueous solution at 25° C. More particularly, the film-forming material can have a viscosity of less than about 250 cP at the above conditions, particularly less than about 100 cP at the above conditions, and in one embodiment, at a viscosity of about 20-60 cP at the above conditions.

[0011] The solids content of the film-forming composition can be at least 6% by weight, particularly at least 10% by weight, and more particularly in an amount from about 10% to about 20% by weight. The film-forming material can be, for instance, an alginate, such as sodium alginate. It should be understood, however, that various other film-forming materials can be used. Other film-forming materials that are believed to be useful in the present invention include guar gum, pectin, polyvinyl alcohol, cellulose derivatives such as ethyl cellulose, methyl cellulose, carboxymethyl cellulose, starch, and starch derivatives.

[0012] The viscosity of the film-forming composition can vary depending upon the manner in which the composition is applied to the paper wrapper. For most applications, however, the viscosity of the film-forming composition should be at least 250 cP, particularly at least 500 cP, more particularly at least 800 cP, and in one embodiment at a viscosity of at least 1000 cP or greater at 25° C. The composition can have a pH of below about 8.0, such as below about 7.5. For example, the pH of the composition can be from about 4 to about 7.5. In one embodiment, the film-forming composition can be heated in order to lower the viscosity of the composition as it is being applied to the paper wrapper.

[0013] The film-forming composition can be applied to the paper wrapper according to various methods. For example, the composition can be printed onto the paper using, for instance, flexography, direct gravure printing, and offset gravure printing.

[0014] In one embodiment, the discrete areas formed by the film-forming composition are in the shape of circumferential bands disposed longitudinally along the smoking article. The bands can have a width of greater than about 3

mm, such as from about 4 mm to about 10 mm. The bands can be spaced from each other at a distance of from about 5 mm to about 50 mm and particularly from about 10 mm to about 40 mm.

[0015] The amount of the film-forming composition that is applied to the paper wrapper depends upon the particular application and various factors. For example, the film-forming composition can be applied to the wrapper in an amount from about 1% to about 30% by weight based upon the weight of the wrapper within the treated areas, and particularly in an amount from about 2% to about 20% by weight.

[0016] Once applied to the paper wrapper, the treated areas can have a permeability of less than about 40 Coresta, particularly less than about 30 Coresta, and more particularly from about 5 Coresta to about 25 Coresta. The initial permeability of the paper wrapper can be from about 20 Coresta to about 90 Coresta or greater.

[0017] Other features and aspects of the present invention are discussed in greater detail below.

BRIEF DESCRIPTION OF THE DRAWINGS

[0018] A full and enabling disclosure of the present invention, including the best mode thereof to one of ordinary skill in the art, is set forth more particularly in the remainder of the specification, including reference to the accompanying figures in which:

[0019] **FIG. 1** is a perspective view of a smoking article made in accordance with the present invention;

[0020] **FIG. 2** is an exploded view of the smoking article illustrated in **FIG. 1**; and

[0021] **FIG. 3** is a system for treating a paper wrapper in accordance with the present invention.

[0022] Repeat use of reference characters in the present specification and drawings is intended to represent same or analogous features or elements of the present invention.

DETAILED DESCRIPTION

[0023] Reference now will be made in detail to the embodiments of the invention, one or more examples of which are set forth below. Each example is provided by way of explanation of the invention, not limitation of the invention. In fact, it will be apparent to those skilled in the art that various modifications and variations can be made in the present invention without departing from the scope or spirit of the invention. For instance, features illustrated or described as part of one embodiment, can be used on another embodiment to yield a still further embodiment. Thus, it is intended that the present invention cover such modifications and variations as come within the scope of the appended claims and their equivalents.

[0024] For purposes of explanation of the invention, the embodiments and principles of the invention will be discussed in regards to a cigarette. However, this is for the purposes of explanation of the invention only and is not meant to limit the invention only to cigarettes. Any manner of smoking article is within the scope and spirit of the invention.

[0025] The invention relates to a smoking article, and a wrapper for a smoking article, having improved ignition proclivity control characteristics. "Ignition proclivity" is a measure of the tendency of the smoking article or cigarette to ignite a flammable substrate if the burning cigarette is dropped or otherwise left on a flammable substrate. A test for ignition proclivity of a cigarette has been established by NIST (National Institute of Standards and Technology) and is generally referred to as the "Mock-Up Ignition Test". The test comprises placing a smoldering cigarette on a flammable test fabric and recording the tendency of the cigarette to either ignite the test fabric, burn the test fabric beyond a normal char line of the fabric, burn its entire length without igniting the fabric, or self-extinguish before igniting the test fabric or burning its entire length.

[0026] Another test for ignition proclivity is referred to as the "Cigarette Extinction Test". In the Cigarette Extinction Test, a lit cigarette is placed on one or more layers of filter paper. If the cigarette self extinguishes, the cigarette passes the test. If the cigarette burns all the way to its end on the filter, however, the cigarette fails. Smoking articles made in accordance with the present invention can be designed to pass one or both of these tests.

[0027] In general, smoking articles having reduced ignition proclivity are made according to the present invention by applying in discrete areas to a wrapping paper a film-forming composition. The film-forming composition contains a film-forming material. In accordance with the present invention, a relatively low viscosity film-forming material is used which allows the composition to contain a higher solids content and yet still be applied to the paper wrapper through conventional techniques, such as printing. By using a lower viscosity material at higher solid levels, the present inventors have discovered that more continuous films are formed that do not contain cracks or other imperfections. Ultimately, it has been discovered that film-forming compositions made in accordance with the present invention are better suited to reducing the permeability of paper wrappers than many conventional formulations.

[0028] It is believed that the general principles of the present invention can be used in conjunction with any suitable film-forming material in producing a film-forming composition. For example, film-forming materials that can be used in accordance with the present invention include alginates, guar gum, pectin, polyvinyl alcohol, cellulose derivatives such as ethyl cellulose, methyl cellulose, and carboxymethyl cellulose, starch, starch derivatives, and the like.

[0029] The process and products made according to the present invention will now be described in greater detail with particular reference to the use of a film-forming composition containing an alginate. It should be understood, however, that the discussion surrounding the use of an alginate is for exemplary purposes only and that it is believed that many other different types of film-forming materials may be incorporated into the process.

[0030] In general, an alginate is a derivative of an acidic polysaccharide or gum which occurs as the insoluble mixed calcium, sodium, potassium and magnesium salt in the Phaeophyceae brown seaweeds. Generally speaking, these derivatives are calcium, sodium, potassium, and/or magnesium salts of high molecular weight polysaccharides com-

posed of varying proportions of D-mannuronic acid and L-guluronic acid. Exemplary salts or derivatives of alginic acid include ammonium alginate, potassium alginate, sodium alginate, propylene glycol alginate, and/or mixtures thereof.

[0031] In the past, alginates have been used to form low permeability areas on cigarette wrapping papers in order to decrease the ignition proclivity characteristics of a smoking article incorporating the wrapper. The alginate solutions used to form the treated areas, however, generally contained a relatively low solids level of the alginate. As described above, however, the present invention is directed to using generally lower viscosity alginates at higher solids levels.

[0032] For example, alginates that may be used according to the present invention have a viscosity of less than about 500 cP when contained in a 3% by weight aqueous solution at 25° C. More particularly, alginates that can be used according to the present invention have a viscosity of less than 250 cP at the above conditions, particularly less than 100 cP, and in one embodiment at a viscosity of about 20-60 cP. As used herein, viscosity is determined by a Brookfield LVF Viscometer. Commercially available alginates that may be used in accordance with the present invention include KELGIN RL, MANUCOL LD AND MANUCOL LB, which are all commercially available from the ISP Corporation.

[0033] At the above lower viscosity levels, alginate compositions can be formed at a higher solids content, but yet at a low enough solution viscosity to permit the application of the composition to a paper wrapper using conventional techniques. For example, the solids content of an alginate solution made in accordance with the present invention can be greater than about 6%, particularly greater than about 10%, and more particularly from about 10% to about 20% by weight.

[0034] At the above solids levels, alginate compositions used in accordance with the present invention can have a solution viscosity of greater than about 250 cP, particularly greater than about 500 cP, more particularly greater than about 800 cP, and in one embodiment at a viscosity of greater than about 1,000 cP at 25° C. In general, the solution viscosity of the alginate film-forming composition can be adjusted depending upon the manner in which the composition is being applied to the paper. For instance, the solution viscosity of the composition can be adjusted depending upon whether or not the composition is being sprayed onto the paper or printed onto the paper.

[0035] In general, alginate compositions made in accordance with the present invention can contain alginate and water. Although not necessary, other ingredients may also be included in the composition. For instance, in one embodiment, a filler can be contained within the composition. The filler can be, for instance, calcium carbonate, calcium chloride, calcium lactate, calcium gluconate, and the like. In addition to calcium compounds, other metal compounds can also be included, including similar magnesium compounds. In one embodiment, the metal cation present in the filler can partially cross-link with the alginate.

[0036] Once the alginate composition or other film-forming composition is formulated, the composition is applied to a paper wrapper in discrete areas. The manner in which the

composition is applied to the paper wrapper can vary. For example, the composition can be sprayed, brushed or printed onto the wrapper. To form a treated area, the composition can be applied in a single pass or in a multiple pass operation. For instance, the composition can be applied to the wrapping paper in successive steps in order to form areas on the paper having reduced ignition proclivity. In general, during a multiple pass process, the treated areas can be formed by applying the composition during from about 2 to about 8 passes.

[0037] The amount of the composition that is applied to the wrapping paper during each successive application of the composition can also vary. For instance, in some applications, the composition is first applied to the wrapping paper at relatively high amounts. In successive steps, the amount of the composition applied to the paper is decreased. In other applications, however, the composition is first lightly applied to the wrapping paper. After initial application, heavier amounts of the composition are then applied to the paper. By varying the amount applied to the wrapping paper during each step, areas having reduced ignition proclivity can be formed on the wrapper with controlled properties.

[0038] Film-forming compositions having a relatively high solids content made in accordance with the present invention have been found well suited to forming reduced ignition proclivity areas on cigarette wrapping papers. Whether used in a single pass operation or in a multi-pass operation, it has been found that the compositions are very effective in reducing the permeability of the paper wrapper in the treated areas and in reducing the ability of a smoking article incorporating the wrapper to ignite adjacent surfaces. Of particular advantage, film-forming compositions made in accordance with the present invention are well suited to shutting down the permeability and the ignition proclivity characteristics of a paper wrapper having a relatively high initial permeability, such as a paper wrapper having a permeability of at least 60 Coresta units.

[0039] In order to assist in describing and explaining the present invention, one embodiment of the invention is illustrated generally in FIGS. 1 and 2. A smoking article (cigarette), generally 10, having improved ignition proclivity characteristics includes a tobacco column 12 within a wrapper 14. Article 10 may include a filter 26. Wrapper 14 may include any manner of commercially available cigarette wrapper.

[0040] Generally, the wrapping paper can be made from cellulosic fibers obtained, for instance, from flax, softwood or hardwood. In order to vary the properties of the paper as desired, various mixtures of cellulosic fibers can be used. The extent to which the fibers are refined can also be varied.

[0041] For most applications, the paper wrapper will contain a filler. The filler can be, for instance, calcium carbonate, magnesium oxide, or any other suitable material. The total filler loading added to the paper wrapper can be between about 10% to about 40% by weight.

[0042] The permeability of a paper wrapper for smoking articles made according to the present invention can generally be from about 10 Coresta units to about 200 Coresta units. In some applications, the permeability can be between about 15 Coresta units to about 55 Coresta units. In one embodiment of the present invention, however, the initial

permeability of the paper wrapper is relatively high. For instance, in one embodiment, the permeability of the paper wrapper can be from about 60 Coresta units to about 110 Coresta units, and particularly from about 60 Coresta units to about 90 Coresta units.

[0043] The basis weight of cigarette wrapping paper is usually between about 18 gsm to about 60 gsm, and more particularly between about 15 gsm to about 40 gsm. Wrapping papers according to the present invention can be made within any of these ranges.

[0044] The wrapping paper may also be treated with a burn control additive, which may also serve as an ash conditioner. Such burn control additives can include, for instance, alkali metal salts, acetates, phosphate salts or mixtures thereof. A particularly preferred burn control additive is a mixture of potassium citrate and sodium citrate. The burn control additive can be added to the paper in an amount from about 0.3% to about 5% by weight, and more particularly from about 0.3% to about 2.5% by weight.

[0045] Paper web 14 defines an outer circumferential surface 16 when wrapped around tobacco column 12. Discrete areas 18 of outer circumferential surface 16 are treated with a film-forming composition made in accordance with the present invention, such as an alginate composition. It should also be understood that treated areas 18 could also be disposed on the inner surface of wrapper 14. In other words, wrapper 14 could be rolled around tobacco column 12 so that treated areas 18 are adjacent to the tobacco.

[0046] In the embodiment illustrated in FIGS. 1 and 2, treated areas 18 are defined as circumferential cross-directional bands 24. Bands 24 are spaced apart from each other longitudinally along the length of cigarette 10. The bands 24 are indicated in phantom in FIG. 2. However, it should be understood that the treated areas are essentially invisible in the formed cigarette as shown in FIG. 1. In other words, a smoker may not discern from any outward sign that the wrapper 14 has been treated in discrete areas 18. In this regard, treated areas 18 have a smooth and flat texture essentially the same as untreated areas 28.

[0047] The width and spacing of bands 24 are dependent on a number of variables, such as the initial permeability of wrapper 14, density of tobacco column 12, etc. The bands 24 preferably have a width so that oxygen is limited to the burning coal for a sufficient length or period of time to extinguish the coal. In other words, if band 24 were too narrow, the burning coal would burn through band 24 before self-extinguishing. For most applications, a minimum band width of 3 mm is desired. For example, the band width can be from about 4 mm to about 10 mm.

[0048] The spacing between bands 24 is also a factor of a number of variables. The spacing should not be so great that the cigarette burns for a sufficient length of time to ignite a substrate before the coal ever burns into a treated area 18. The spacing between bands 24 also affects the thermal inertia of the burning coal, or the ability of the coal to burn through the treated bands 24 without self-extinguishing. In the cigarettes tested, applicants have found that a band spacing of between 5 and 50 mm is appropriate and particularly between about 10 mm and 40 mm. However, it should be understood that the band spacing can be any suitable width as determined by any number of variables.

For most applications, the smoking article can contain from 1 to about 3 bands using the above spacing.

[0049] Treated areas 18 have a permeability within a range which is known to provide improved ignition proclivity characteristics for the make-up of cigarette 10. As the coal of cigarette 10 burns into treated areas 18, oxygen available to the burning coal is substantially reduced due to the decreased permeability of wrapper 14 in the treated areas. The reduction of oxygen preferably causes the cigarette to self-extinguish in the treated areas 18 when in contact with a substrate. Applicants have determined that a preferred permeability is less than 40 ml/min/cm² (CORESTA), particularly less than 30 ml/min/cm², and generally within a range of 5 to 25 ml/min/cm². Applicants have found that this range provides the desired self-extinguishing results as the cigarette coal burns into the treated areas.

[0050] Besides permeability, another measurement that can be used to indicate reduced ignition proclivity properties is Burn Mode Index. In fact, the Burn Mode Index of a paper wrapper can be more accurate in indicating the burning characteristics of a paper as opposed to simply measuring the permeability of the paper. The test for determining Burn Mode Index is explained in U.S. Pat. No. 4,739,775 to Hampl, which is incorporated herein by reference.

[0051] In order to exhibit reduced ignition proclivity properties, the Burn Mode Index ("BMI") of the treated areas 18 can be generally less than about 8 cm⁻¹, and particularly from about 1 cm⁻¹ to about 5 cm⁻¹. For instance, in one embodiment, the burn mode index of the treated areas 18 can be from about 1 cm⁻¹ to about 3 cm⁻¹.

[0052] The composition applied to wrapper 14 in treated areas 18 provides the reduced permeability in the treated areas.

[0053] The amount of composition that is added to the paper will depend upon various factors, including the type of composition that is used and the desired result. For most applications, the film-forming composition, can be added to the paper in an amount from about 1% to about 30% by weight of the paper within the banded region, and particularly from about 2% to about 20% by weight of the paper within the banded region after the bands have been formed and dried. Although not always the case, generally the amount of the composition applied to the paper will generally increase as the permeability of the paper increases. For instance, for wrapping papers having a permeability of less than about 30 Coresta units, the composition can be applied to a paper in an amount from about 1% to about 15% by weight. For wrapping papers having a permeability greater than about 60 Coresta units, on the other hand, the composition can be applied to the paper in an amount from about 8% to about 30% by weight.

[0054] The present invention pertains to a smoking article wrapper for use with smoking articles, as essentially described above, as well as a method for making the smoking article wrapper.

[0055] As described above, the composition can be sprayed, brushed, or printed onto the wrapper. In general, any suitable printing process can be used in the present invention. Applicants have found that suitable printing techniques include gravure printing, or flexographic printing. In one embodiment, as illustrated in FIG. 3, a paper layer 14

is unwound from a supply roll **40** and travels in the direction indicated by the arrow associated therewith. Alternatively, the paper layer **14** may be formed by one or more paper-making processes and passed directly into the process **50** without first being stored on a supply roll **40**.

[**0056**] As shown in **FIG. 3**, the paper layer **14** passes through the nip of an S-roll arrangement **42** in a reverse-S path. From the S-roll arrangement **42**, the paper layer **14** passes to a gravure printing arrangement **44**. The gravure printing process may be a direct print process or an indirect print process, such as by using an offset printer. **FIG. 3** depicts an indirect print process.

[**0057**] The gravure printing arrangement contains a composition tank **46** and a doctor blade **48** which is used to apply a composition **52** to a gravure roll **54**.

[**0058**] The gravure roll **54** may be engraved with a conventional continuous cell pattern (e.g., quadrangular cell pattern) arranged in parallel bands across the width of the roll with nonengraved areas between each band. Each gravure cell holds a small amount of the composition which is released in a pattern onto a rubber applicator roll **56**. The paper layer **14** passes through a nip between the rubber applicator roll **56** and a cooperating backup roll **58**. The composition is transferred from the applicator roll **56** to the surface of the paper layer **14** thereby forming a coated paper **60**. The speeds of the gravure roll **54** and the applicator roll **58** may be controlled so they are the same or so they differ by a minor amount to influence the application of the composition. Once the composition is applied to the paper layer **14**, the paper layer can be dried if desired.

[**0059**] For instance, as shown in **FIG. 3**, after leaving the gravure printing arrangement **44**, the paper web **14** is passed through a drying operation **62**. During the drying operation **62**, the treated paper can be dried using various devices and methods. For example, in one embodiment, the drying operation **62** includes a drying device that passes hot gas such as air over the paper web. The temperature of the air can range from about 100° F. to about 600° F. In an alternative embodiment, the drying device can be a steam can. After being treated with a composition by the gravure printing device, the paper web can be placed in contact with the steam can for drying the composition.

[**0060**] Besides drying the paper with a hot gas stream or with a steam can, in another embodiment of the present invention the paper can be dried by contacting the paper with infra-red rays. For example, in one embodiment, the paper can be passed under a infra-red heating lamp.

[**0061**] In still another alternative embodiment of the present invention, the paper web **14** can be simply air dried during the drying operation **62**.

[**0062**] It should be understood that the process illustrated in **FIG. 3** represents merely one embodiment for applying a composition to the paper wrapper. For instance, a greater amount of printing stations may be included at any location for applying the composition in a multi-pass process.

[**0063**] These and other modifications and variations to the present invention may be practiced by those of ordinary skill in the art, without departing from the spirit and scope of the present invention. In addition, it should be understood that aspects of the various embodiments may be interchanged

both in whole or in part. Furthermore, those of ordinary skill in the art will appreciate that the foregoing description is by way of example only, and is not intended to limit the invention.

What is claimed:

1. A smoking article having reduced ignition proclivity characteristics comprising:

a column comprising a smokable tobacco; and

a paper wrapper surrounding the column of the smokable tobacco, the paper wrapper including discrete areas treated with a film-forming composition, the treated areas being separated by untreated areas, the treated areas having a permeability within a range sufficient to reduce ignition proclivity, the film-forming composition applied to the paper wrapper comprising a film-forming material contained in a solution in an amount sufficient for the solution to have a solids content of at least 6% by weight, the film-forming material having a viscosity of less than about 500 cP when present in a 3% by weight solution at 25° C.

2. A smoking article as defined in claim 1, wherein the film-forming material comprises an alginate.

3. A smoking article as defined in claim 2, wherein the alginate is sodium alginate.

4. A smoking article as defined in claim 1, wherein the solution has a solids content of at least 10% by weight.

5. A smoking article as defined in claim 1, wherein the film-forming material has a viscosity of less than about 250 cP when present in a 3% by weight solution at 25° C.

6. A smoking article as defined in claim 1, wherein the film-forming material has a viscosity of less than about 100 cP when present in a 3% by weight solution at 25° C.

7. A smoking article as defined in claim 1, wherein the treated areas have a permeability of less than about 40 Coresta.

8. A smoking article as defined in claim 1, wherein the film-forming material comprises a material selected from the group consisting of guar gum, pectin, polyvinyl alcohol, a cellulose derivative, starch, a starch derivative, and mixtures thereof.

9. A smoking article as defined in claim 1, wherein the treated areas have a BMI of from about 1 cm⁻¹ to about 5 cm⁻¹.

10. A smoking article as defined in claim 1, wherein the treated areas are printed onto the paper wrapper.

11. A smoking article as defined in claim 1, wherein the untreated areas of the paper wrapper have a permeability of greater than about 60 Coresta.

12. A smoking article as defined in claim 1, wherein the treated areas comprise a plurality of discrete circumferential bands disposed longitudinally along the smoking article.

13. A smoking article as defined in claim 12, wherein the bands are spaced from each other at a distance of from about 5 mm to about 50 mm, the bands having a width of greater than about 3 mm.

14. A smoking article as defined in claim 1, wherein the treated areas further comprise a citrate, the citrate being present within the bands in an amount from about 1% to about 3% by weight of the wrapper.

15. A paper wrapper for a smoking article that provides the smoking article with reduced ignition proclivity characteristics comprising:

a paper web designed to surround a smokable filler, the paper web including discrete areas treated with a film-forming composition, the treated areas being separated by untreated areas, the treated areas having a permeability within a range sufficient to reduce ignition proclivity of a smoking article incorporating the wrapper, the film-forming composition applied to the paper wrapper comprising a film-forming material contained in a solution in an amount sufficient for the solution to have a solids content of at least 6% by weight, the film-forming material having a viscosity of less than about 500 cP when present in a 3% by weight solution at 25° C.

16. A paper wrapper as defined in claim 15, wherein the film-forming material comprises an alginate.

17. A paper wrapper as defined in claim 16, wherein the alginate is sodium alginate.

18. A paper wrapper as defined in claim 15, wherein the solution has a solids content of at least 10%.

19. A paper wrapper as defined in claim 15, wherein the film-forming material has a viscosity of less than about 250 cP when present in a 3% by weight solution at 25° C.

20. A paper wrapper as defined in claim 15, wherein the film-forming material has a viscosity of less than about 100 cP when present in a 3% by weight solution at 25° C.

21. A paper wrapper as defined in claim 15, wherein the film-forming material comprises a material selected from the group consisting of guar gum, pectin, polyvinyl alcohol, a cellulose derivative, starch, a starch derivative, and mixtures thereof.

22. A paper wrapper as defined in claim 15, wherein the treated areas are printed onto the paper wrapper.

23. A paper wrapper as defined in claim 15, wherein the untreated areas of the paper wrapper have a permeability of greater than about 60 Coresta.

24. A paper wrapper as defined in claim 15, wherein the treated areas comprise a plurality of discrete circumferential bands disposed longitudinally along the smoking article, the bands having a width of greater than about 3 mm, the bands being spaced from each other at a distance of from about 5 mm to about 50 mm.

25. A process for producing a paper wrapper having reduced ignition proclivity characteristics when incorporated into a smoking article comprising the following steps:

providing a paper wrapper comprised of a paper web; and

applying a film-forming composition to said paper wrapper at particular locations, said film-forming composition forming treated discrete areas on said wrapper, the treated areas being separated by untreated areas, the treated discrete areas having a permeability within a range sufficient to reduce ignition proclivity, the film-forming composition comprising a film-forming material contained in a solution in an amount sufficient for the solution to have a solids content of at least 6% by weight, the film-forming material having a viscosity of less than about 500 cP when present in a 3% by weight solution at 25° C.

26. A process as defined in claim 25, wherein the film-forming material comprises an alginate.

27. A process as defined in claim 26, wherein the alginate is a sodium alginate.

28. A process as defined in claim 25, wherein the film-forming material is present in the solution such that the solution has a solids content of at least 15% by weight.

29. A process as defined in claim 25, wherein the film-forming material has a viscosity of less than about 250 cP when present in a 3% by weight solution at 25° C.

30. A process as defined in claim 25, wherein the film-forming material has a viscosity of less than about 100 cP when present in a 3% by weight solution at 25° C.

31. A process as defined in claim 25, wherein the treated areas have a permeability of less than about 40 Coresta.

32. A process as defined in claim 25, wherein the film-forming material is a material selected from the group consisting of guar gum, pectin, polyvinyl alcohol, a cellulose derivative, starch, a starch derivative, and mixtures thereof.

33. A process as defined in claim 25, wherein the treated areas have a BMI of from about 1 cm⁻¹ to about 5 cm⁻¹.

34. A process as defined in claim 25, wherein the film-forming composition is printed onto the paper wrapper.

35. A process as defined in claim 34, wherein the film-forming composition is printed onto the paper wrapper in a multi-pass operation.

36. A process as defined in claim 25, wherein the treated areas comprise a plurality of discrete circumferential bands disposed longitudinally along the smoking article, the bands having a width of greater than 3 mm, the bands being spaced from each other from a distance of from about 4 mm to about 30 mm.

37. A process as defined in claim 25, wherein the film-forming composition is applied to the paper wrapper using gravure printing.

38. A process as defined in claim 25, wherein the film-forming composition is applied to the paper wrapper in the treated discrete areas in an amount up to about 30% by weight based upon the weight of the paper wrapper.

39. A process for producing a paper wrapper having reduced ignition proclivity characteristics when incorporated into a smoking article comprising the following steps:

providing a paper wrapper comprised of a paper web, the paper web containing a filler; and

printing a film-forming composition on said paper wrapper at particular locations to form treated discrete areas on the wrapper, the treated discrete areas being separated by untreated areas, the treated discrete areas having a permeability within a range sufficient to reduce the ignition proclivity characteristics of a smoking article without causing the smoking article to self extinguish in a free burn state, the film-forming composition comprising an aqueous solution containing an alginate, the solution containing the alginate in an amount so as to have a solids content of at least 8% by weight, the alginate having a viscosity of less than about 250 cP when present in a 3% by weight aqueous solution at 25° C., the treated areas forming circumferential bands along the length of the paper wrapper when incorporated into a smoking article, the treated

areas having a permeability of less than about 30 Coresta and having a BMI of less than about 5 cm^{-1} , the film-forming composition being applied to the paper wrapper in the treated areas in an amount of from

about 2% to about 20% by weight based upon the weight of the wrapper.

* * * * *