

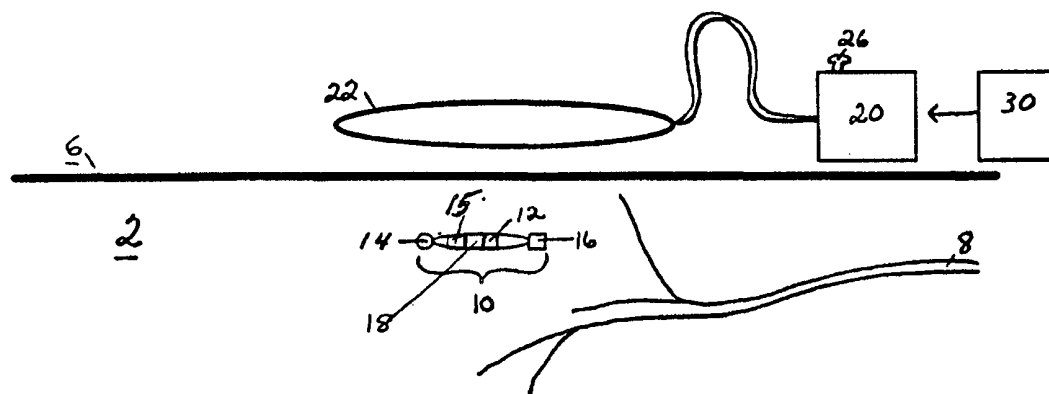

INTERNATIONAL APPLICATION PUBLISHED UNDER THE PATENT COOPERATION TREATY (PCT)

(51) International Patent Classification ⁶ : A61F	A2	(11) International Publication Number: WO 00/01320 (43) International Publication Date: 13 January 2000 (13.01.00)
<p>(21) International Application Number: PCT/US99/14775</p> <p>(22) International Filing Date: 29 June 1999 (29.06.99)</p> <p>(30) Priority Data: 60/091,762 6 July 1998 (06.07.98) US</p> <p>(71) Applicant (for all designated States except US): ADVANCED BIONICS CORPORATION [US/US]; 12740 San Fernando Road, Sylmar, CA 91342 (US).</p> <p>(72) Inventors; and (75) Inventors/Applicants (for US only): LOEB, Gerald, E. [US/US]; 19348 Wing Foot Circle, Northridge, CA 91326 (US). MANN, Carla, M. [US/US]; 14175 Mulholland Drive, Beverly Hills, CA 90210 (US). RICHMOND, Francis, J., R. [CA/US]; 19348 Wing Foot Circle, Northridge, CA 91326 (US).</p> <p>(74) Agent: GOLD, Bryant, R.; Advanced Bionics Corporation, 12740 San Fernando Road, Sylmar, CA 91342 (US).</p>	<p>(81) Designated States: AU, CA, JP, US, European patent (AT, BE, CH, CY, DE, DK, ES, FI, FR, GB, GR, IE, IT, LU, MC, NL, PT, SE).</p> <p>Published <i>Without international search report and to be republished upon receipt of that report.</i></p>	

(54) Title: IMPLANTABLE STIMULATOR SYSTEM AND METHOD FOR TREATMENT OF URINARY INCONTINENCE



PROGRAMMING SYSTEM FOR IMPLANTABLE MICROSTIMULATOR

(57) Abstract

A method and system for treatment of urinary incontinence includes the injection or laparoscopic implantation of one or more battery- or radiofrequency-powered microstimulators (10) beneath the skin of the perineum. The devices are programmed using radio-frequency control via an external controller (20, 30) that can be used by a physician to produce patterns of output stimulation pulses judged to be efficacious by appropriate clinical testing to diminish incontinence symptoms. The stimulation program is retained in the microstimulator device (10) or external controller (20) and is transmitted when commanded to start and stop by a signal from the patient or caregiver. The system and method reduce the incidence of unintentional episodes of bladder emptying by stimulating nerve pathways (8) that diminish involuntary bladder contractions, improve closure of the bladder outlet, and/or improve the long-term health of the urinary system by increasing bladder capacity and emptying. Further, the system and method allow a patient to be taught to receive one or more patterns of neural stimulation that can be prescribed by a physician and administered without continuous oversight by a clinical practitioner.

FOR THE PURPOSES OF INFORMATION ONLY

Codes used to identify States party to the PCT on the front pages of pamphlets publishing international applications under the PCT.

AL	Albania	ES	Spain	LS	Lesotho	SI	Slovenia
AM	Armenia	FI	Finland	LT	Lithuania	SK	Slovakia
AT	Austria	FR	France	LU	Luxembourg	SN	Senegal
AU	Australia	GA	Gabon	LV	Latvia	SZ	Swaziland
AZ	Azerbaijan	GB	United Kingdom	MC	Monaco	TD	Chad
BA	Bosnia and Herzegovina	GE	Georgia	MD	Republic of Moldova	TG	Togo
BB	Barbados	GH	Ghana	MG	Madagascar	TJ	Tajikistan
BE	Belgium	GN	Guinea	MK	The former Yugoslav Republic of Macedonia	TM	Turkmenistan
BF	Burkina Faso	GR	Greece	ML	Mali	TR	Turkey
BG	Bulgaria	HU	Hungary	MN	Mongolia	TT	Trinidad and Tobago
BJ	Benin	IE	Ireland	MR	Mauritania	UA	Ukraine
BR	Brazil	IL	Israel	MW	Malawi	UG	Uganda
BY	Belarus	IS	Iceland	MX	Mexico	US	United States of America
CA	Canada	IT	Italy	NE	Niger	UZ	Uzbekistan
CF	Central African Republic	JP	Japan	NL	Netherlands	VN	Viet Nam
CG	Congo	KE	Kenya	NO	Norway	YU	Yugoslavia
CH	Switzerland	KG	Kyrgyzstan	NZ	New Zealand	ZW	Zimbabwe
CI	Côte d'Ivoire	KP	Democratic People's Republic of Korea	PL	Poland		
CM	Cameroon	KR	Republic of Korea	PT	Portugal		
CN	China	KZ	Kazakstan	RO	Romania		
CU	Cuba	LC	Saint Lucia	RU	Russian Federation		
CZ	Czech Republic	LI	Liechtenstein	SD	Sudan		
DE	Germany	LK	Sri Lanka	SE	Sweden		
DK	Denmark	LR	Liberia	SG	Singapore		
EE	Estonia						

- 1 -

IMPLANTABLE STIMULATOR SYSTEM AND METHOD FOR TREATMENT OF URINARY INCONTINENCE

This application claims priority to, and the benefit of, prior United States patent application Serial Number 60/091,762, filed 06 July 1998, which
5 application is incorporated herein by reference.

Background of the Invention

The present invention relates to implantable stimulator systems, and more particularly to an implantable stimulator system utilizing one or more implantable microstimulators for treating urinary incontinence.

10 Urinary Incontinence is a clinical condition characterized by failure to hold urine in the bladder under normal conditions of pressure and filling. The disorder can arise from either a failure of muscles around the bladder neck and urethra to maintain closure of the urinary outlet (so-called stress incontinence) or from abnormally heightened commands from the spinal cord to the bladder
15 that produce unanticipated bladder contractions (so-called urge incontinence). Many patients exhibit a grouping of symptoms suggesting that these disorders may occur simultaneously in the same individual (so-called mixed incontinence).

It is well known in the art that electrical stimulation in the region of the pelvic floor can decrease the severity of incontinence. The improvement is
20 believed to be attained through at least three mechanisms: (1) by changing the reflex thresholds of the bladder muscles responsible for bladder emptying, (2) by strengthening the muscles that maintain closure on the bladder outlet, and (3) by changing the state of the neural pathways, musculature and/or bladder beyond the period of stimulus application.

- 2 -

The therapies currently available for incontinence have generally been directed at improving muscle condition, as disclosed, e.g., in applicant's prior document WO97/18857 (PCT/US96/18680), published 29 May 1997. Bladder hyper-reflexia and detrusor instability have proven more difficult to treat.

5 However, evidence in the art suggests that it can be improved in many individuals by stimulating peripheral nerves or nerve roots continuously or intermittently to modulate transmission of excitatory nerve signals to the bladder muscles.

Several external and implantable approaches have been used to
10 stimulate the nerves supplying the bladder and pelvic region in order to decrease the episodic incidences of unintentional bladder emptying. Those who strengthen periurethral muscles have usually employed vaginal or anal electrode assemblages to stimulate muscle contractions repeatedly. These methods are limited in their portability and are often poorly accepted by patients because they
15 are inconvenient and often associated with unpleasant skin sensations. Further, the methods are inadequate for the treatment of urge incontinence in which continual electrical stimulation is commonly needed to diminish or inhibit the heightened reflexes of bladder muscles.

For the treatment of urge incontinence, surgically implanted
20 stimulators under battery or radio-frequency control have been described in the art. These stimulators have different forms, but are usually comprised of an implantable control module to which is connected a series of leads that must be routed to nerve bundles in either the sacral roots emanating from the spinal cord, or the nerves supplying muscles, skin or other structures in the pelvic region.

- 3 -

The implantable devices are relatively large, expensive and challenging to implant surgically. Thus, their use has generally been confined to patients with severe symptoms and capacity to finance the surgery.

More recently, small implantable microstimulators have been
5 introduced that can be injected into soft tissues through a cannula or needle
See, e.g., U.S. Patent Numbers 5,324,316 and 5,405,367, both of which patents
are incorporated herein by reference. What is needed is a way to effectively use
such small implantable microstimulators for the purpose of treating urinary
incontinence.

10 Summary of the Invention

The system and method taught in this invention includes the
injection or laparoscopic implantation of one or more battery- or radio-frequency-
powered microstimulators beneath the skin of the perineum. The devices are
programmed using radio-frequency control via an external controller that can be
15 used by a physician to produce patterns of output stimulation pulses judged to
be efficacious by appropriate clinical testing to diminish incontinence symptoms.
Such stimulation program is retained in the device or external controller and is
transmitted when commanded to start and stop by a signal from the patient or
caregiver.

20 It is an object of this invention to reduce the incidence of
unintentional episodes of bladder emptying by stimulating nerve pathways that
diminish involuntary bladder contractions, improve closure of the bladder outlet,

- 4 -

and/or improve the long-term health of the urinary system by increasing bladder capacity and emptying.

It is a further object of this invention to teach a method whereby a patient can receive one or more patterns of neural stimulation that can be
5 prescribed by a physician and administered without continuous oversight by a clinical practitioner.

It is a feature of the invention to meet the above-identified objects of the invention using a system of small implantable microstimulators of the type described in, or similar to those described in, the above-referenced patents
10 and/or patent applications.

Brief Description of the Drawings

The above and other aspects, features and advantages of the present invention will be more apparent from the following more particular description thereof, presented in conjunction with the following drawings wherein:

15 FIG. 1 illustrates a programming system for use with an implantable microstimulator; and

FIG. 2 shows an insertion system for use with an implantable microstimulator.

Corresponding reference characters indicate corresponding
20 components throughout the several views of the drawings.

Detailed Description of the Invention

The following description is of the best mode presently

- 5 -

contemplated for carrying out the invention. This description is not to be taken in a limiting sense, but is made merely for the purpose of describing the general principles of the invention. The scope of the invention should be determined with reference to the claims.

5 Advantageously, the small size of the microstimulators referenced above permits insertion of these devices beneath the skin of the perineum, where they have the capability to stimulate the nerves and muscles in regions surrounding the urethra and anus. For purposes of this patent application, it is sufficient to note that radio-frequency controlled microstimulators receive power
10 and control signals from an extra corporeal antenna coil via inductive coupling of a modulated radio-frequency field. Battery-operated microstimulators incorporate a power source within the device itself but rely on radio-frequency control to program stimulus sequences and to recharge the power source, when needed. In accordance with the present invention, each implanted
15 microstimulator may be commanded to produce an electrical pulse of a prescribed magnitude and duration and at a repetition rate sufficient to cause stimulation of nerve axons.

 The ability to implant small, less expensive microstimulators by injection or laparoscopic insertion, rather than major surgery, significantly
20 reduces the expense and complication rates of implantable technologies for urinary incontinence. For some patients, use of the stimulator for only a few hours per day or week will improve the symptomatology of incontinence. In such patients, RF controlled devices provide an adequate amount of stimulation if used intermittently for only a few hours per day to greatly decrease the incidence

- 6 -

of incontinent episodes. For many other patients, however, a continuous or intermittent stimulation throughout the day is needed. These patients may best utilize a stimulator that has a self-contained power source sufficient to deliver repeated pulses for several hours and that can be recharged repeatedly. In
5 accordance with the teachings of the present invention, the use of a microstimulator with a rechargeable battery thus provides these patients the portability needed to free the patient from reliance on radio-frequency power delivery.

A battery-powered microstimulator suitable for use with the present
10 invention, and a control system for use with such battery-powered microstimulator, is fully described in: WO98/37926, published 3 September 1998; WO98/43700, published 8 October 1998; and WO98/43701, published 8 October 1998; which publications are incorporated herein by reference.

Turning to FIG. 1, a preferred embodiment of the invention is
15 illustrated. As seen in FIG. 1, a rechargeable, battery-powered microstimulator 10 is implanted into subcutaneous region 2, where current pulses delivered from its electrodes 14 and 16 stimulate nerve fibers 8. Nerve bundles in the subcutaneous region may carry somatic sensory axons supplying receptors in skin and muscle and somatic motor axons supplying skeletal muscle, as well as
20 autonomic axons supplying visceral and glandular structures and smooth muscle.

When a sensory nerve is stimulated, it produces an electrical impulse that is transmitted along the axon into the dorsal horn of the spinal cord,

- 7 -

where it can produce perceptible sensations, modulation of spinal cord circuits and reflex effects on motor pathways.

When a motor nerve is stimulated, electrical impulses are conveyed through its many peripheral branches that supply muscle fibers and
5 elicit contractions in them.

Electronic circuit 12, contained within the microstimulator 10, dictates the amplitude and duration of the electrical current pulse, thereby determining the number of nerve fibers excited by each pulse. Electronic circuit 12 receives operating power and (if a battery 15 is included within the
10 microstimulator) recharge power for battery 15 and data to be stored in memory element 18 by inductive coupling from external controller 20 and its associated antenna coil 22.

During an initial programming session after implantation of microstimulator 10, the prescribing physician uses a programming station 30 to
15 download a pattern of stimulus pulse delivery to controller 20, which saves the information in nonvolatile memory. Each time the microstimulators 10 are recharged by controller 20, the stimulation parameters required from each microstimulator 10 are transmitted via coil 22, along with the power required for recharging. The stimulation parameters are stored in the memory element 18 of
20 each microstimulator 10 as long as battery 15 has sufficient power to operate the microstimulator circuitry. Program delivery is initiated by start and stop commands delivered by patient-governed control switch 26. In the preferred embodiment, controller 20 is a hand-held module containing a microprocessor and appropriate nonvolatile memory, such as electronically erasable

- 8 -

programmable read-only-memory (EEPROM). However, it will be evident to those of skill in electronic circuitry and computing that *many* different *system* architectures and components could be used to achieve similar functionality with either a battery-powered or radiofrequency-powered microstimulator device.

5 A preferred stimulation location for purposes of the present invention is the pelvic floor. Direct stimulation of the pelvic floor nerves bypasses the potential recruitment of other unrelated nerve groups at the sacral roots. Other nerves in this region that may be targeted for stimulation include the pudendal nerve, pelvic nerve and the clitoral branches of the pudendal
10 nerve.

Stimulation parameters of pudendal nerve and sacral root stimulation will generally fall in the following ranges:

Frequency: 2-20 pulses per second (pps).

Duration: 50-350 microseconds (μ s).

15 Amplitude: 1-5 volts at about 1-50 milliamps (mA).

It is to be understood that the above ranges are not absolute. Rather, they provide a guide for the stimulation parameters to be used. One of the attractive features provided by the invention is that the stimulation parameters can be adjusted, as required, until an appropriate and efficacious
20 stimulation regime is achieved.

The microstimulators of the type described in the referenced patents and patent publications represent a new class of generic implantable stimulators. These devices are microminiature, single-channel stimulators that can be injected through a 12 gauge needle, or similar device, in and around

- 9 -

nerves and muscles. Under control of an RF coupled external transmitter, microstimulators provide precise patterns of muscle activation with a variety of programmable pulse durations and intensities. While each microstimulator is a single channel unit, the same external unit may control up to 256
5 microstimulators that then work in harmonious combination to create a multichannel neuro-muscular control network. Because the microstimulators are injectable, they are minimally invasive, and may be injected in an outpatient environment posing little clinical risk, and reducing costs. If necessary, such microstimulators may be removed through a small surgical incision.

10 Advantageously, by implanting one or more microstimulators in the manner described herein so as to selectively stimulate appropriate nerves and/or tissue, it is possible to create a system which: (1) reduces the incidence of unintentional episodes of bladder emptying by stimulating nerve pathways that diminish involuntary bladder contractions, (2) improves closure of the bladder
15 outlet, and/or (3) improves the long-term health of the urinary system by increasing bladder capacity and emptying.

In accordance with the present invention, a microstimulator is injected into soft tissues by using an insertion device whose preferred embodiment is shown in FIG 2. The hollow cannula 110 of the insertion device
20 is comprised of a stiff dielectric material with sufficient lubricity to permit the undamaged passage of device 10 therethrough. Probe 120 is a rigid, electrically conductive trochar whose sharply pointed end extends beyond the end of the tube. The trochar is used to deliver electrical impulses to the tissue at its end. Electrical stimuli can be delivered by means of the trochar 120 by connecting an

- 10 -

electrical stimulator (not shown) to connector 122 on the trochar. The initial insertion site of the trochar, guided by a clinical knowledge of tissue landmarks or radiographic images, may be modified until stimulation produces excitation of nerves 8 judged by perceptible sensations or clinical demonstration of desired effects on bladder or periurethral muscle. Satisfactory stimulation of nerves 8 will ensure that the end of the rod around the trochar is located in an appropriate site sufficiently close to nerves 8 so that electrical stimulation using the microstimulator will also produce the desired nerve excitation. Insertion of the microstimulator is accomplished by removing trochar 120 and passing the microstimulator through the hollow cannula 110 using, e.g., a blunt-ended push-rod 130.

It is thus seen that the invention provides a system which reduces the incidence of unintentional episodes of bladder emptying by stimulating nerve pathways that diminish involuntary bladder contractions, improve closure of the bladder outlet, and/or improve the long-term health of the urinary system by increasing bladder capacity and emptying.

It is further seen that the invention provides a method whereby a patient can receive one or more patterns of neural stimulation that can be prescribed by a physician and administered without continuous oversight by a clinical practitioner.

Further, it is seen that the invention provides such a system and method using small implantable microstimulators that may be implanted in the desired tissue/nerve-stimulating locations by injection or laparoscopic insertion rather than major surgery.

- 11 -

While the invention herein disclosed has been described by means of specific embodiments and applications thereof, numerous modifications and variations could be made thereto by those skilled in the art without departing from the scope of the invention set forth in the claims.

- 12 -

CLAIMS

What is claimed is:

1. A method to remediate urinary incontinence by delivering trains of electrical pulses to nerves (8) supplying tissues in the perineum and pelvic floor
5 (2) through at least one implantable microstimulator (10), each microstimulator (10) comprising an hermetically-sealed chamber separating a plurality of exposed electrodes (14, 16) for delivering electrical current and an electronic means (12) within said chamber for generating electrical current, said microstimulator being of a size and shape capable of implantation through a
10 laparoscope or hypodermic needle.
2. The method of Claim 1 wherein delivery of the electrical pulses to the nerves supplying tissues in the perineum and pelvic floor is supplied through a multiplicity of implantable microstimulators (10).
3. The method of Claim 1 wherein the at least one implantable
15 microstimulator further includes a self-contained power source (15) housed within the hermetically-sealed chamber for supplying operating power to the electronic means (12) within the microstimulator, and wherein the method further comprises recharging and programming the implantable power source as needed from an external, non-implanted, location.

- 13 -

4. The method of Claim 3 further including charging the implantable self-contained power source (15) with sufficient energy to allow the microstimulator to provide a continuous or intermittent stimulation throughout the day as needed, wherein the self-contained power source (15) powers the
5 microstimulator (10) to deliver repeated pulses for several hours, thereby providing patients portability that allows them to be free from reliance on radio-frequency power delivery.

5. The method of Claim 1 further including powering the at least one implantable microstimulator (10) using radio-frequency operating power and
10 control signals received from an external, non-implanted, control unit (20).

6. The method of Claim 5 further including using the at least one microstimulator (10) intermittently for only a few hours per day or week to improve the symptomatology of incontinence.

7. A method to modulate the excitability of peripheral and central
15 neural circuits by delivering trains of electrical pulses to peripheral nerves (8) using at least one implanted microstimulator (10), each microstimulator (10) comprising an hermetically-sealed chamber separating a plurality of exposed electrodes (14, 16) for delivering electrical current, and an electronic means (12) within said chamber for generating electrical current, said microstimulator being
20 of a size and shape capable of implantation through a laparoscope or hypodermic needle.

- 14 -

8. A system for producing repeatable patterns of electrical stimulation in peripheral nerves (8) supplying structures in the pelvis and perineum (2), said system comprising at least one implantable microstimulator (10), each microstimulator (10) consisting of an hermetically-sealed chamber separating a plurality of exposed electrodes (14, 16) for delivering electrical current through the electrodes, and an electronic means (12) within said chamber for generating electrical current, said microstimulator being of a size and shape capable of implantation through a laparoscope or hypodermic needle, plus at least one control unit (20) with memory means for retaining at least one pattern of electrical stimulation and actuator means (26) for initiating the reproduction of said pattern of electrical stimulation.

9. The system of Claim 8 wherein the at least one implantable microstimulator (10) includes a rechargeable battery (15) housed within the hermetically-sealed chamber, wherein the rechargeable battery supplies operating power for operation of the microstimulator, and wherein the at least one control unit includes means for recharging the rechargeable battery.

10. The system of Claim 8 wherein the at least one implantable microstimulator includes means for receiving operating power and control signals from the at least one control unit (20).

- 15 -

11. The system of Claim 10 wherein the operating power is received via a radio-frequency (RF) signal from an extra corporeal antenna coil (22) via inductive coupling of a modulated RF field.

12. The system of Claim 8 wherein the microstimulators are inserted
5 beneath the skin of the perineum, where they stimulate the nerves and muscles in regions surrounding the urethra and anus.

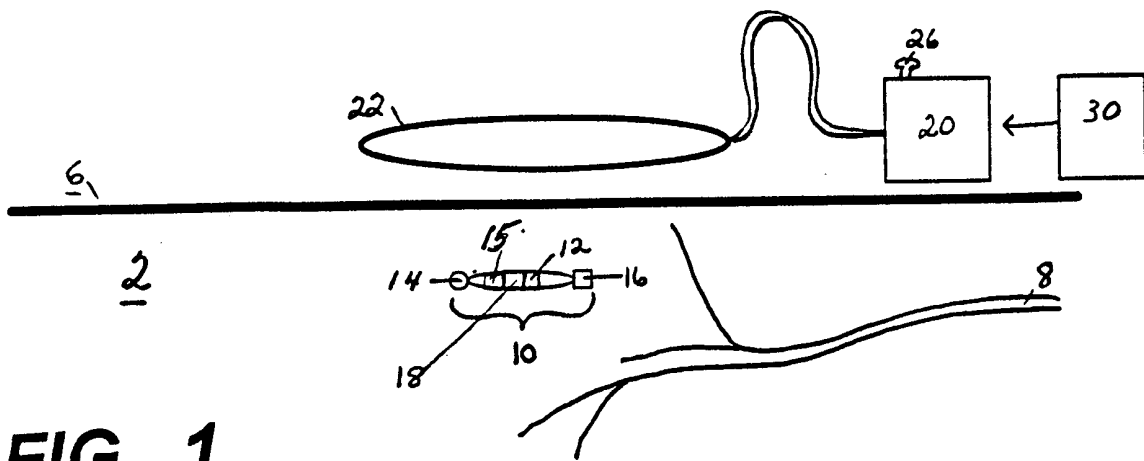

FIG. 1

Figure 1: Programming system for implantable microstimulator

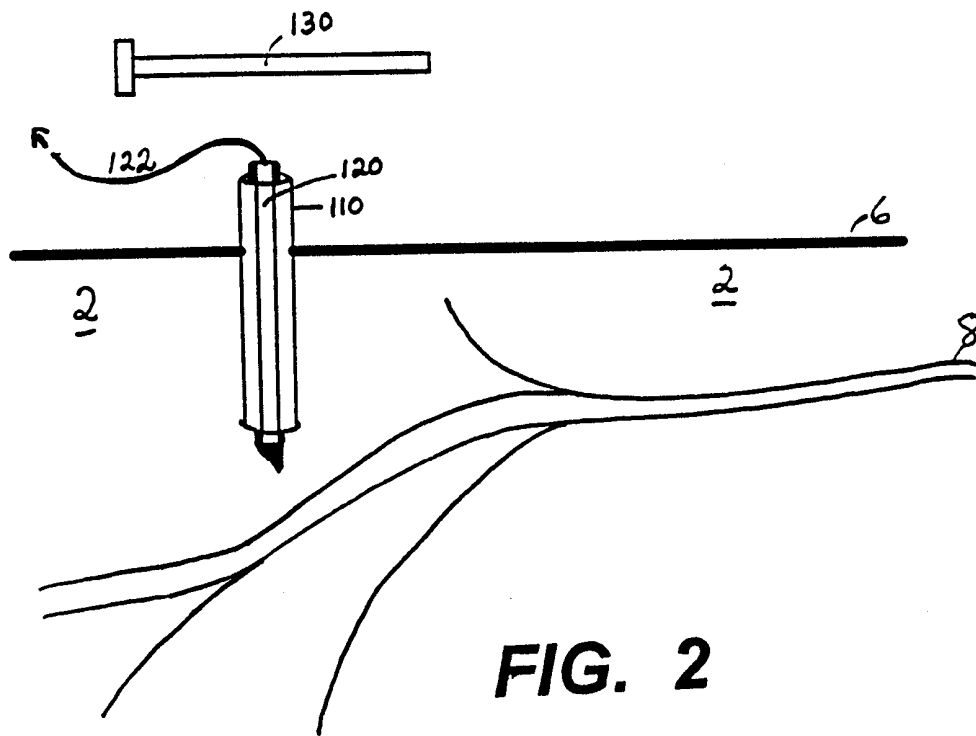

FIG. 2

Figure 2: Insertion System for Implantable Microstimulator