

(12) STANDARD PATENT
(19) AUSTRALIAN PATENT OFFICE

(11) Application No. **AU 2008231166 B2**

(54) Title
Passive screw locking mechanism

(51) International Patent Classification(s)
A61B 17/80 (2006.01)

(21) Application No: **2008231166** (22) Date of Filing: **2008.02.27**

(87) WIPO No: **WO08/118599**

(30) Priority Data

(31) Number	(32) Date	(33) Country
11/691,760	2007.03.27	US

(43) Publication Date: **2008.10.02**

(44) Accepted Journal Date: **2011.01.20**

(71) Applicant(s)
DePuy Spine, Inc.

(72) Inventor(s)
Riley, John;Fanger, Jonathan;Jacene, Michael

(74) Agent / Attorney
Callinans, 1193 Toorak Road, Camberwell, VIC, 3124

(56) Related Art
US 2003/0199876
US 2004/0068319
US 2005/0059970
US 2005/0027296

(19) World Intellectual Property Organization
International Bureau



(43) International Publication Date
2 October 2008 (02.10.2008)

PCT

(10) International Publication Number
WO 2008/118599 A1

- (51) **International Patent Classification:**
A61B 17/80 (2006.01)
- (21) **International Application Number:**
PCT/US2008/055085
- (22) **International Filing Date:**
27 February 2008 (27.02.2008)
- (25) **Filing Language:** English
- (26) **Publication Language:** English
- (30) **Priority Data:**
11/691,760 27 March 2007 (27.03.2007) US
- (71) **Applicant (for all designated States except US):** DEPUY SPINE, INC. [US/US]; 325 Paramount Drive, Raynham, MA 02767 (US).
- (72) **Inventors; and**
- (75) **Inventors/Applicants (for US only):** JACENE, Michael [US/US]; 5 Federal Street, Blackstone, MA 01504 (US). FANGER, Jonathan [US/US]; 34 Lewin Street, Fall River, MA 02720 (US). RILEY, John [US/US]; 40 Cook Road, Cumberland, RI 02864 (US).
- (74) **Agents:** ADAMS, Lisa et al.; Nutter McClennen & Fish Llp, World Trade Center West, 155 Seaport Boulevard, Boston, MA 02210-2604 (US).

- (81) **Designated States (unless otherwise indicated, for every kind of national protection available):** AE, AG, AL, AM, AO, AT, AU, AZ, BA, BB, BG, BH, BR, BW, BY, BZ, CA, CH, CN, CO, CR, CU, CZ, DE, DK, DM, DO, DZ, EC, EE, EG, ES, FI, GB, GD, GE, GH, GM, GT, HN, HR, HU, ID, IL, IN, IS, JP, KE, KG, KM, KN, KP, KR, KZ, LA, LC, LK, LR, LS, LT, LU, LY, MA, MD, ME, MG, MK, MN, MW, MX, MY, MZ, NA, NG, NI, NO, NZ, OM, PG, PH, PL, PT, RO, RS, RU, SC, SD, SE, SG, SK, SL, SM, SV, SY, TJ, TM, TN, TR, TT, TZ, UA, UG, US, UZ, VC, VN, ZA, ZM, ZW.
- (84) **Designated States (unless otherwise indicated, for every kind of regional protection available):** ARIPO (BW, GH, GM, KE, LS, MW, MZ, NA, SD, SL, SZ, TZ, UG, ZM, ZW), Eurasian (AM, AZ, BY, KG, KZ, MD, RU, TJ, TM), European (AT, BE, BG, CH, CY, CZ, DE, DK, EE, ES, FI, FR, GB, GR, HR, HU, IE, IS, IT, LT, LU, LV, MC, MT, NL, NO, PL, PT, RO, SE, SI, SK, TR), OAPI (BF, BJ, CF, CG, CI, CM, GA, GN, GQ, GW, ML, MR, NE, SN, TD, TG).

Published:

- with international search report
- before the expiration of the time limit for amending the claims and to be republished in the event of receipt of amendments

(54) **Title:** PASSIVE SCREW LOCKING MECHANISM

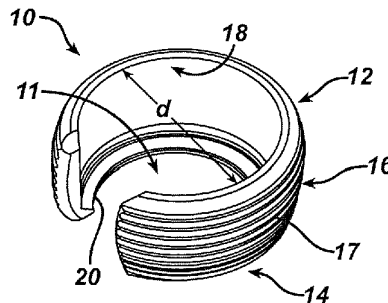

FIG. 1A

(57) **Abstract:** Methods and devices are provided for passively locking a bone screw within a bone plate. In particular, the methods and devices allow a bone screw to be locked within a thru-hole in a bone plate without requiring any additional locking steps. In an exemplary embodiment, an annular feature is provided in a thru-hole of a bone plate, or in a bushing that is disposed within a thru-hole of a bone plate, for engaging a bone screw. The annular feature can be configured such that it allows the bone screw to be inserted through the thru-hole at various insertion angles while still being effective to prevent back-out of the bone screw, thereby locking the screw to the plate.



WO 2008/118599 A1

PASSIVE SCREW LOCKING MECHANISM

FIELD OF THE INVENTION

The present invention relates to bone fixation methods and devices, and in particular to a passive locking mechanism for mating a bone screw to a bone plate.

BACKGROUND OF THE INVENTION

Bone fixation devices are useful for promoting the proper healing of injured or damaged vertebral bone segments caused by trauma, tumor growth, or degenerative disc disease. These external fixation devices immobilize the injured bone segments to ensure the proper growth of new osseous tissue between the damaged segments. External bone fixation devices such as these often include internal bracing and instrumentation to stabilize the spinal column to facilitate the efficient healing of the damaged area without deformity or instability, while minimizing any immobilization and post-operative care of the patient.

One type of external bone fixation device is an osteosynthesis plate, more commonly referred to as a bone plate, that can be used to immobilize adjacent skeletal parts such as vertebral bones. Typically, the fixation plate is a rigid metal or polymeric plate positioned to span bones or bone segments that require immobilization with respect to one another. The plate is fastened to the respective bones, using anchors such as bone screws, so that the plate remains in contact with the bones and fixes them in a desired position. Anterior cervical plates, for instance, can be useful in providing the mechanical support necessary to keep vertebral bodies in proper position and bridge a weakened or diseased area such as when a disc, vertebral body or spinal fragment has been removed. These anterior cervical plates usually include a rigid bone plate having a plurality of screw openings. The openings are either holes or slots that allow for freedom of screw movement. The bone plate is placed against the damaged vertebral bodies and bone screws are used to secure the bone plate to the spine, usually with the bone screws being driven into the vertebral bodies.

While current bone plates and bone screws are effective, unintentional loosening of the screws can reduce the effectiveness of an anterior construct and can result in erosion and irritation of the esophagus. Several techniques have been developed to

5 prevent screw back-out, however many current techniques require the use of a second locking mechanism that is applied to the bone screw or plate. This can complicate the procedure, as it requires the use of additional tools as well as proper placement of the additional locking mechanism. Other existing techniques require precise alignment of the bone screw with the thru-hole in the bone plate, thereby limiting the insertion trajectory of the bone screw.

10 Accordingly, there remains a need for improved methods and devices for locking a bone screw to a bone plate.

SUMMARY OF THE INVENTION

15 Methods and devices are provided for passively locking a bone screw to a bone plate.

20 In accordance with a first aspect of the present invention, therefore, there is provided a locking plate apparatus, including: a body having a thru-hole formed therein and an annular feature formed on an internal surface of the thru-hole, the annular feature residing in a single plane and having an inner diameter, wherein the body includes a bushing having the thru-hole formed therein, the bushing being adapted to be seated within a thru-hole in a bone plate; and a bone screw having a threaded shaft with threads having a major diameter that is greater than the inner diameter of the annular feature such that the annual feature extends between the threads on the threaded shaft upon insertion of the threaded shaft through the thru-hole.

25 In accordance with another aspect of the present invention there is provided a screw locking device, including: a split bushing adapted to be seated within a thru-hole in a bone plate, the bushing including an annular feature formed on an internal surface thereof and residing in a plane perpendicular to an axis of the thru-hole; and a bone screw having a threaded shank adapted to be passed through the split bushing for engaging bone and a head adapted to be at least partially disposed within the split

bushing, the annular feature being configured to abut a proximal-most surface of threads on the threaded shank to retain the bone screw within the split bushing.

5 The body can have a variety of configurations, for example the body can be a bone plate having the thru-hole formed therein. In another embodiment, the body can be a bushing having the thru-hole formed therein. The bushing can be adapted to be seated within a thru-hole in a bone plate. In certain exemplary embodiments, the bushing is split, e.g., c-shaped. The bushing can also include a radial exterior surface sized to permit polyaxial rotation of the bushing within a thru-hole in a bone plate.

10 The bone screw can also have a variety of configurations, but in an exemplary embodiment the bone screw includes a head that is formed on a proximal end of a threaded shaft and that is adapted to be at least partially seated within the thru-hole in the body. The threaded shaft can have an outer or major diameter that is greater than an inner diameter of the annular feature, and an inner or minor diameter that is less than an inner diameter of the annular feature, such that the annular feature engages the threads when the bone screw is inserted through the thru-hole. The bone screw can also include an annular groove formed on or adjacent to the head and/or the threaded shaft for seating the annular feature. The bone screw can also have other features. For example, the head of the bone screw can be tapered for seating within a corresponding tapered portion of the thru-hole.

25 The annular feature can also have a variety of configurations. The annular feature can be, for example, an annular flange disposed around an inner surface of the thru-hole, or a plurality of flanges or tabs spaced annularly around an inner surface of the thru-hole. In an exemplary embodiment, the annular feature resides within a single plane, which can optionally be perpendicular to a longitudinal axis of the thru-hole. In use, the annular feature can be sized to engage threads on the bone screw and to retain the bone screw within the body.

In accordance with a further aspect of the present invention there is provided a method for locking a bone screw within a plate, including: positioning a body having a thru-hole on a bone surface, the thru-hole including a bushing disposed therein and having an annular feature formed on an internal surface thereof; and inserting a bone screw through the bushing and into bone, threads on the bone screw engaging the annular feature as the bone screw is inserted through the bushing; wherein the annular feature resides in a single plane such that the bone screw can be inserted through the bushing at various insertion angles relative to an axis of the thru-hole.

Threads on the bone screw can engage the annular feature as the bone screw is inserted through the thru-hole. In an exemplary embodiment, the annular feature resides in a single plane such that the bone screw can be inserted through the thru-hole at various insertion angles relative to an axis of the thru-hole. Once implanted, the annular feature will retain the bone screw within the thru-hole thereby preventing back-out.

BRIEF DESCRIPTION OF THE DRAWINGS

The invention will be more fully understood from the following detailed description taken in conjunction with the accompanying drawings, in which:

FIG. 1A is a perspective view of one embodiment of a bushing having an annular feature formed therein;

FIG. 1B is a top view of the bushing of FIG. 1A;

FIG. 1C is a side cross-sectional view of the bushing of FIG. 1A;

FIG. 2A is a top view of another embodiment of a bushing having an annular feature formed therein;

FIG. 2B is a perspective view of the bushing of FIG. 2A;

FIG. 3A is a side view of one embodiment of a bone screw;

FIG. 3B is a side view of another embodiment of a bone screw;

FIG. 4 is a top view of one embodiment of a bone plate;

FIG. 5 is a side cross-sectional view of the bone screw of FIG. 3A disposed within the bushing of FIG. 1A, which is seated in a thru-hole of the bone plate of FIG. 4;

FIG. 6 is an illustration showing the bone screw, bushing, and bone plate of FIG. 5 in use in bone.

DETAILED DESCRIPTION OF THE INVENTION

Certain exemplary embodiments will now be described to provide an overall understanding of the principles of the structure, function, manufacture, and use of the devices and methods disclosed herein. One or more examples of these embodiments are illustrated in the accompanying drawings. Those skilled in the art will understand that the devices and methods specifically described herein and illustrated in the accompanying drawings are non-limiting exemplary embodiments and that the scope of the present invention is defined solely by the claims. The features illustrated or described in connection with one exemplary embodiment may be combined with the features of other embodiments. Such modifications and variations are intended to be included within the scope of the present invention.

The present invention generally provides methods and devices for passively locking a bone screw within a bone plate. In particular, the methods and devices allow a bone screw to be locked within a thru-hole in a bone plate without requiring any additional locking steps. In an exemplary embodiment, an annular feature is provided in a thru-hole of a body, such as a bone plate or a bushing that is disposed within a thru-hole of a bone plate, for engaging a bone screw. The annular feature can be configured such that it allows the bone screw to be inserted through the thru-hole at various

insertion angles while still being effective to prevent back-out of the bone screw, thereby locking the screw to the plate. A person skilled in the art will appreciate that, while the invention is described as not requiring any additional locking steps, various locking mechanisms known in the art can be used in combination with the passive locking feature disclosed herein.

As indicated above, in one embodiment an annular feature is provided in a thru-hole of a bone plate, or in a bushing that is disposed within a thru-hole of a bone plate, for engaging a bone screw. FIGS. 1A-1C illustrate one exemplary embodiment of an annular feature 20 that is formed around an inner surface 18 of a thru-bore 11 in a bushing 10. The particular configuration of the bushing 10 can vary, but the illustrated bushing 10 is a split bushing that is generally C-shaped. Other slot or cut-out configurations can be used to allow radial expansion of the bushing, or alternatively the bushing can be ring-shaped. The illustrated bushing 10 generally includes a first or proximal end 12 that is configured to lie adjacent to a proximal surface of a bone plate, and a second or distal end 14 that is configured to lie adjacent to a distal, bone-contacting surface of a bone plate, as will be discussed in more detail below. An outer surface 16 of the bushing 10 can be sized and shaped to match the inner surface of the thru-hole in a bone plate. As shown in FIG. 1A, the outer surface of the bushing has a generally convex spherical shape extending between the first and second ends 12, 14 such that the bushing 10 can be seated within a thru-hole having a generally concave spherical inner surface extending between first and second surfaces of the bone plate. This will allow the bushing 10 to move polyaxially relative to the plate. The outer surface 16 of the bushing 10 can also include surface features formed thereon to facilitate frictional engagement with the thru-hole in a bone plate. FIGS. 1A and 1C illustrate ridges 17 extending radially around the bushing 10. A variety of other surface features or textures can be used to facilitate engagement between the bushing 10 and a thru-hole, or alternatively the bushing 10 can have a smooth outer surface. The inner surface 18 of the bushing 10 can also have a variety of configurations, but in an exemplary embodiment the inner surface 18 has a diameter d that decreases from the proximal end 12 to the distal end 14 such that the thru-bore 11 is tapered.

Continuing to refer to FIGS. 1A-1C, the annular feature 20 can have a variety of configurations but in the illustrated embodiment the annular feature 20 is in the form of an annular flange or protrusion that extends radially around the inner surface 18 of the bushing 10. The diameter D_1 of the annular feature 20 can vary, but it is preferably sized to engage the threads of the bone screw to prevent screw back-out once the bone screw is implanted. In an exemplary embodiment, the annular feature 20 has a diameter D_1 that is greater than a major or outer diameter of the threads of a bone screw inserted therethrough, and that is less than a minor or inner diameter of the threads of a bone screw inserted therethrough (i.e., the diameter of the shank). The inner diameter D_1 of the annular feature 20 is also preferably smaller than the smallest outer diameter of a head of the bone screw so as to prevent the head of the bone screw from passing therethrough. Exemplary bone screws will be discussed in more detail below with respect to FIGS. 3A and 3B.

The particular location of the annular feature 20 within the thru-hole 11 of the bushing 10 can also vary. In the illustrated embodiment the annular feature 20 is positioned adjacent to a distal end of the thru-hole 11, i.e., adjacent to the distal-most end 14 of the bushing 10. This configuration will allow the annular feature to engage the bone screw at a location between the shank and the head, as will be discussed in more detail below. A person skilled in the art will appreciate that the annular feature can be located at any portion in the bushing, and that the particular location can vary depending on the configuration of the bone screw. Moreover, while a bushing is shown, the annular feature can be formed in a thru-hole in a bone plate such that the bone plate has a thru-hole with the same configuration as thru-hole 11.

As further shown in FIGS. 1A-1C, the annular feature 20 can also reside in a single plane P such that the annular feature 20 is non-helical or non-threaded. The angle of the plane P relative to a central axis A of the thru-hole 11 can vary. For example, the annular feature 20 can reside in a plane P that extends at an angle α that is greater than or less than 90° relative to the central axis A of the thru-hole 11. In the illustrated embodiment, the annular feature 20 resides in a plane P that is perpendicular to the central axis A of the thru-hole 11 such that the plane P extends at an angle α of 90° relative to the central axis A . In use, the planar configuration of the annular feature 20 will allow a bone screw to be inserted at various trajectories or insertion angles relative

to the thru-hole 11, as the annular feature 20 will extend between the threads without requiring the tight constraints and proper alignment that are necessary with a thread-on-thread connection. A person skilled in the art will appreciate that the thru-hole 11 can, however, include a partial thread formed therein, in addition to the annular feature, for positioning the bone screw at a predetermined trajectory relative to the thru-hole. Moreover, while only one annular feature is shown, the thru-hole 11 can include multiple annular features residing in separate planes.

FIGS. 2A-2B illustrate yet another embodiment of an annular feature 20' that is configured to lock a bone screw within a thru-hole in a plate. As with the embodiment shown in FIGS. 1A-1C, the annular feature 20' is formed within a thru-hole 11' of a bushing 10' and resides in a single plane. The annular feature 20' also similarly has an inner diameter D_1' that is greater than a major diameter of the threads on a bone screw, but less than a minor diameter of the threads on the bone screw, as will be discussed in more detail below. In this embodiment, however, rather than extending around an entire inner surface 18' of the bushing 10', the annular feature 20' is in the form of multiple protrusions or flanges that are positioned annularly around an inner surface 18' of the bushing 10'. FIGS. 2A-2B illustrate three protrusions spaced radially around the inner surface 18' of the bushing 10'.

As indicated above, the annular feature can be configured to engage a bone screw to lock the bone screw to a bone plate. FIG. 3A illustrates one exemplary embodiment of a bone screw 30 for use with the bushings 10, 10' shown in FIGS. 1A-2B. In general, the bone screw 30 includes a head 32 and a shank 34 extending distally therefrom. The head 32 can be sized to be at least partially received within a thru-hole 11, 11' in the bushing 10, 10', or within a thru-hole in a bone plate. In an exemplary embodiment, the head 32 has a diameter d_h that is greater than the inner diameter D_1, D_1' of the annular feature 20, 20' such that the annular feature 20, 20' prevents passage of the head 32 through the thru-hole 11, 11'. The shank 34 includes threads 36 formed thereon and extending between proximal and distal ends 34a, 34b of the shank 34. The shape of the tip of bone screw 30 can vary, and the tip can be self-drilling or self-tapping if desired. In order to allow the annular feature 20, 20' to lock the bone screw 30 to a bone plate, the threads 36 on the shank 34 can have a major diameter D_2 that is greater than the inner diameter D_1, D_1' of the annular feature 20, 20', and a minor diameter D_3 , i.e.,

the diameter of the shank, that is less than the inner diameter D_1 , D_1' of the annular feature 20, 20'. This will allow the annular feature 20, 20' to extend between the threads 36 as the bone screw 30 is threaded therethrough. As previously indicated, since the annular feature 20, 20' resides in a single plane, the bone screw 30 can be inserted at various trajectories or insertion angles relative to the annular feature 20, 20', thus allowing easy insertion of the bone screw 30 into bone.

As further shown in FIG. 3A, the bone screw 30 can include an annular groove 38 formed on or adjacent to the head 32 and/or the proximal end 34a of the shank 34. In the illustrated embodiment, the groove 38 is located between the proximal end of the shank 34 and the head 32. A person skilled in the art will appreciate that in describing the groove as being formed "between" the head 32 and the shank 34, the groove can necessarily be formed on only one of the head 32 and the shank 34, or on a portion of both the head 32 and the shank 34. The threads 36 on the shank 34 can also continue into the groove 38 and terminate at the head 32, as shown in FIG. 3A, or they can terminate prior to the groove. FIG. 3B illustrates a bone screw 30' having threads 36' that terminate prior to a groove 38' 3B. In use, the annular groove 38 is configured to seat the annular feature 20, 20' on the bushing (or on a bone plate) once the bone screw 30 is threaded therethrough, as will be discussed in more detail below. In an exemplary embodiment, the annular groove 30 has a height h that is greater than a height of the annular feature 20, 20'. This will allow the bone screw 30 to be fully threaded into bone without interference from the annular feature 20, 20'. A person skilled in the art will appreciate that the bone screw can have a variety of configurations, and that various bone screws known in the art can be used.

FIG. 4 illustrates one exemplary embodiment of a bone plate 40 that can be used with the bushings 10, 10' of FIGS. 1A-2B and with the bone screws 30, 30' of FIGS. 3A and 3B. As shown, the bone plate 40 has a generally planar configuration with a first, superior surface 42 and a second, inferior bone-contacting surface 44. The plate 40 can include any number of thru-holes formed therein and extending between the superior and inferior surfaces 42, 44. In the illustrated embodiment, the plate 40 includes four thru-holes 46 formed therein for receiving four bone screws. The plate 40 can also include additional features to facilitate use of the implant. In this embodiment, each thru-hole 46 is sized and shaped to seat a bushing therein such that, when a bone screw

is inserted through the bushing and into bone, an interference fit is created between the head of the bone screw, the bushing, and the thru-hole 46 in the plate 40.

In use, the annular feature will lock the bone screw to the plate. In particular, a bushing can be disposed within a thru-hole in a plate (or alternatively the annular feature can be formed directly in the thru-hole in the plate). The plate can be positioned against a bone surface, such as against a vertebra in a spinal column. Once the bone is prepared, e.g., by drilling, tapping, etc., a bone screw can be passed through the thru-hole in the bushing (or the thru-hole in the plate where the annular feature is formed in the plate) and threaded into bone. FIGS. 5 and 6 illustrate the bone screw 30 of FIG. 3A disposed through the bushing 10 of FIGS. 1A-1C, which is seated within a thru-hole 26 in the plate 40 of FIG. 4. As shown, the annular feature 20 is disposed within the annular groove 38 formed around the bone screw 30 such that the annular feature 20 will abut the proximal-most surface 36p of the thread 36 on the bone screw 30 to prevent the screw 30 from backing out of the plate 40. Thus, in order to remove the bone screw 30 from the bone plate 40, the screw 30 will need to be unthreaded. The annular feature 20 is therefore effective to passively lock the bone screw 30 to the plate 40, as additional locking mechanisms are not required.

One skilled in the art will appreciate further features and advantages of the invention based on the above-described embodiments. Accordingly, the invention is not to be limited by what has been particularly shown and described, except as indicated by the appended claims. All publications and references cited herein are expressly incorporated herein by reference in their entirety.

What is claimed is:

The claims defining the invention are as follows:

1. A locking plate apparatus, including: a body having a thru-hole formed therein and an annular feature formed on an internal surface of the thru-hole, the annular feature residing in a single plane and having an inner diameter, wherein the body includes a bushing having the thru-hole formed therein, the bushing being adapted to be seated within a thru-hole in a bone plate; and a bone screw having a threaded shaft with threads having a major diameter that is greater than the inner diameter of the annular feature such that the annular feature extends between the threads on the threaded shaft upon insertion of the threaded shaft through the thru-hole.
2. The apparatus of claim 1, wherein the bushing is c-shaped.
3. The apparatus of claim 1 or claim 2, wherein the bushing includes a radial exterior surface sized to permit polyaxial rotation of the bushing within a thru-hole in a bone plate.
4. The apparatus of any one of claims 1 to 3, further including a bone plate having a thru-hole formed therein and sized to seat the bushing.
5. The apparatus of any one of the preceding claims, wherein the threaded shaft has an outer diameter that is greater than an inner diameter of the annular feature.
6. The apparatus of any one of the preceding claims, wherein the bone screw includes a head formed on a proximal end of the threaded shaft and adapted to be at least partially seated within the thru-hole.
7. The apparatus of claim 6, further including an annular groove formed between the head and the threaded shaft and adapted to seat the annular feature.

8. The apparatus of claim 6 or claim 7, wherein the head is tapered and at least a portion of the thru-hole is tapered for seating the head.

5 9. The apparatus of any one of the preceding claims, wherein the annular feature includes an annular flange disposed around an inner surface of the thru-hole.

10. The apparatus of any one of claims 1 to 8, wherein the annular feature includes a plurality of tabs spaced annularly around an inner surface of the thru-hole.

10 11. A screw locking device, including:

a split bushing adapted to be seated within a thru-hole in a bone plate, the bushing including an annular feature formed on an internal surface thereof and residing in a plane perpendicular to an axis of the thru-hole; and

15 a bone screw having a threaded shank adapted to be passed through the split bushing for engaging bone and a head adapted to be at least partially disposed within the split bushing, the annular feature being configured to abut a proximal-most surface of threads on the threaded shank to retain the bone screw within the split bushing.

20 12. The device of claim 11, wherein the annular feature retains the bone screw within the bushing using an interference fit.

25 13. The device of claim 11 or claim 12, wherein the annular feature is positioned to engage an annular groove formed between the head and the threaded shank of the bone screw.

14. The device of any one of claims 11 to 13, further including a plate having a thru-hole formed therein for receiving the split bushing.

30 15. The device of any one of claims 11 to 14, wherein the threads have a major diameter that is greater than an inner diameter of the annular feature, and the

threaded shank has a minor diameter that is less than an inner diameter of the annular feature.

5 16. The device of any one of claims 11 to 15, wherein the annular feature is adapted to engage the threaded shank.

17. The device of any one of claims 11 to 16, wherein the annular feature includes an annular flange disposed around an inner surface of the thru-hole.

10 18. The device of any one of claims 11 to 16, wherein the annular feature includes a plurality of tabs spaced annularly around an inner surface of the thru-hole.

19. A method for locking a bone screw within a plate, including:
positioning a body having a thru-hole on a bone surface, the thru-hole
15 including a bushing disposed therein and having an annular feature formed on an internal surface thereof; and
inserting a bone screw through the bushing and into bone, threads on the
bone screw engaging the annular feature as the bone screw is inserted through the
bushing; wherein the annular feature resides in a single plane such that the bone
20 screw can be inserted through the bushing at various insertion angles relative to an axis of the thru-hole.

20. The method of claim 19, wherein the annular feature engages an annular
groove formed between a head and a threaded shank of the bone screw.
25

21. The method of claim 19 or claim 20, wherein the annular feature retains the
bone screw within the thru-hole by an interference fit.

22. A locking plate apparatus, substantially as described herein with reference
30 to the accompanying drawings.

23. A screw locking device, substantially as described herein with reference to the accompanying drawings.
24. A method for locking a bone screw within a plate, substantially as described
5 herein with reference to the accompanying drawings.

FIG. 1A

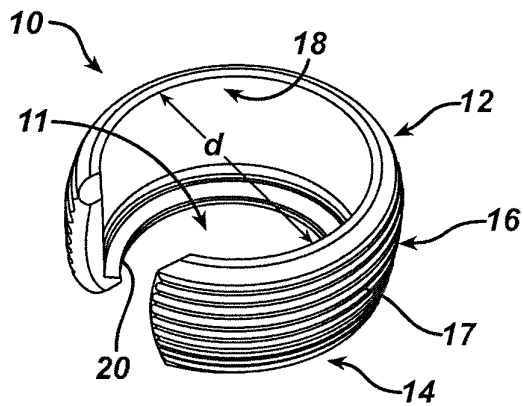

FIG. 1B

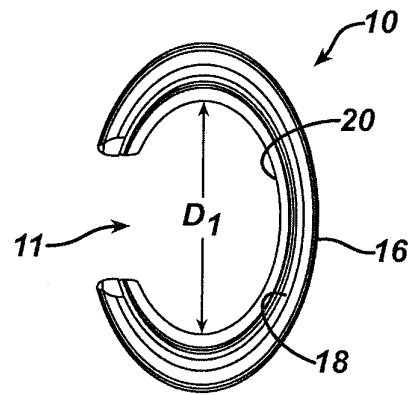

FIG. 1C

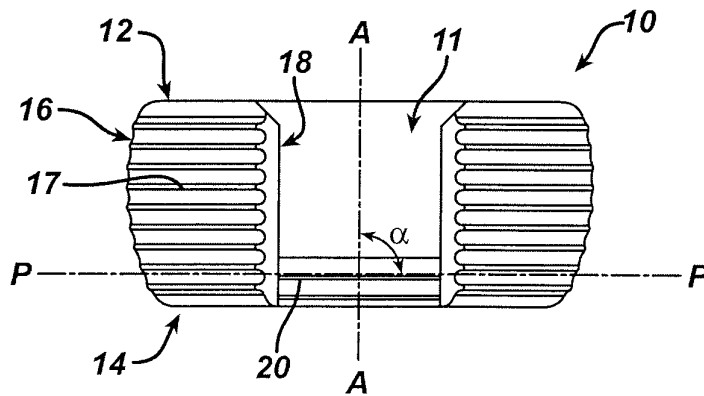

FIG. 2A

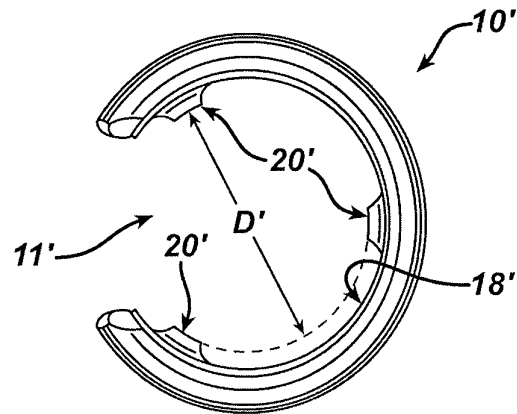

FIG. 2B

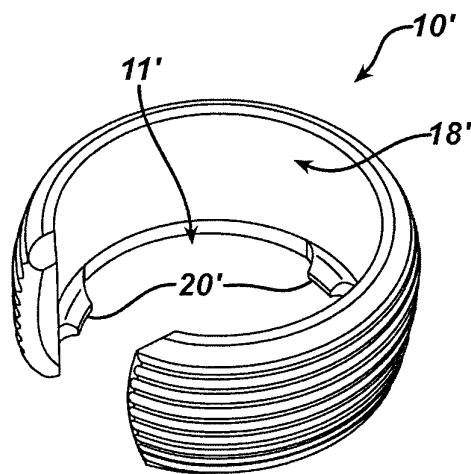

FIG. 3A

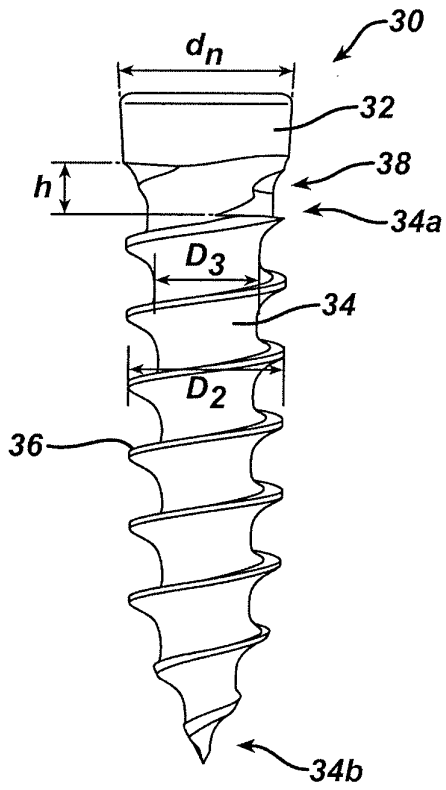

FIG. 3B

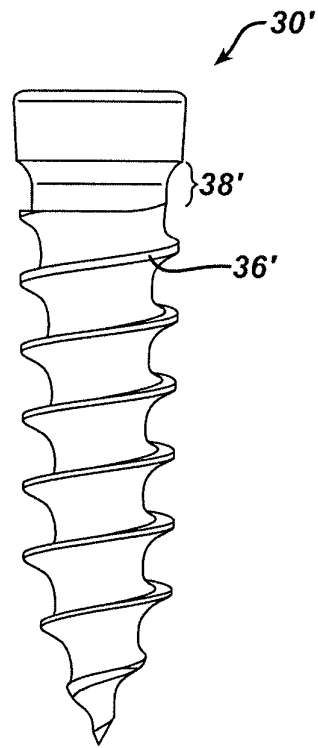

FIG. 4

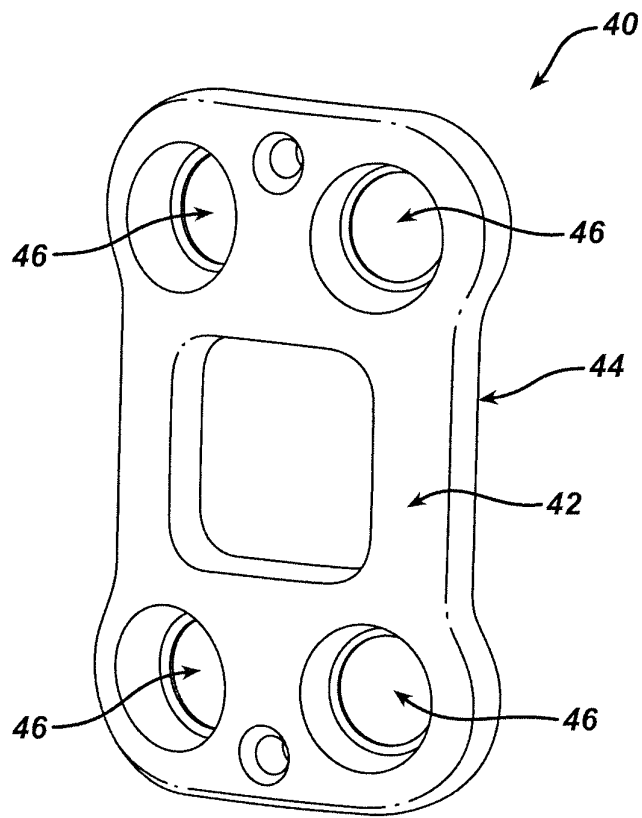

FIG. 5

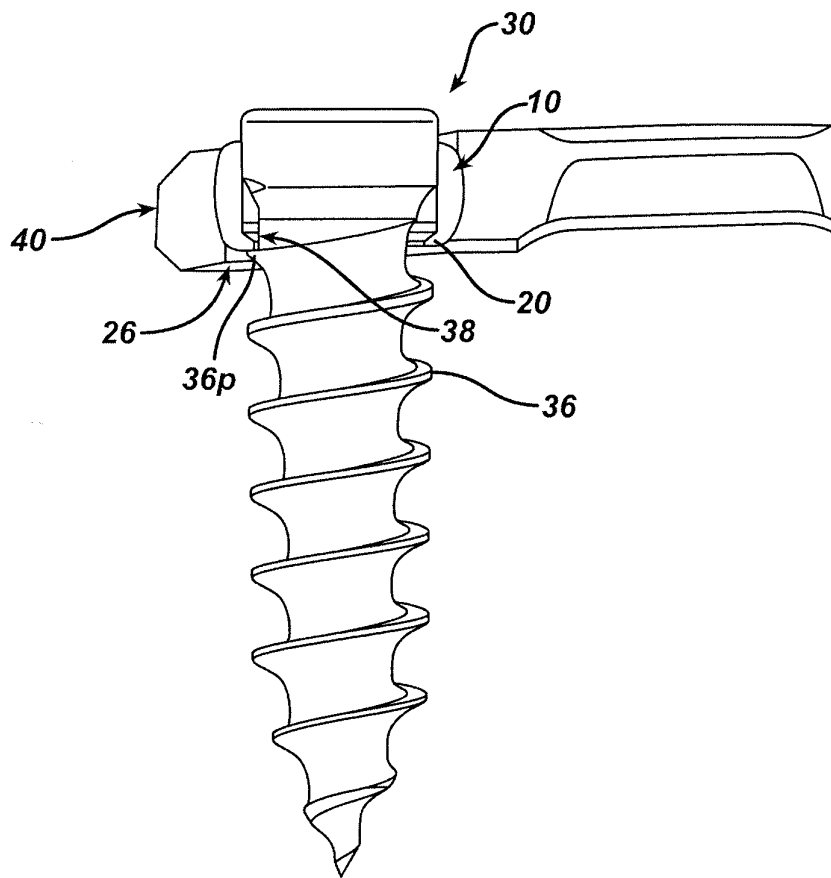

FIG. 6

