



US 20070032706A1

(19) **United States**

(12) **Patent Application Publication**

**Kamath et al.**

(10) **Pub. No.: US 2007/0032706 A1**

(43) **Pub. Date: Feb. 8, 2007**

(54) **SYSTEMS AND METHODS FOR REPLACING SIGNAL ARTIFACTS IN A GLUCOSE SENSOR DATA STREAM**

(76) Inventors: **Apurv Kamath**, Solana Beach, CA (US); **James H. Brauker**, San Diego, CA (US); **Aarthi Mahalingam**, San Diego, CA (US); **Ying Li**, San Diego, CA (US)

Correspondence Address:  
**KNOBBE MARTENS OLSON & BEAR LLP**  
**2040 MAIN STREET**  
**FOURTEENTH FLOOR**  
**IRVINE, CA 92614 (US)**

(21) Appl. No.: **11/498,410**

(22) Filed: **Aug. 2, 2006**

**Related U.S. Application Data**

(63) Continuation-in-part of application No. 10/648,849, filed on Aug. 22, 2003.  
Continuation-in-part of application No. 11/007,920, filed on Dec. 8, 2004.  
Continuation-in-part of application No. 11/077,739, filed on Mar. 10, 2005.

(60) Provisional application No. 60/528,382, filed on Dec. 9, 2003. Provisional application No. 60/587,787, filed on Jul. 13, 2004. Provisional application No. 60/587,800, filed on Jul. 13, 2004. Provisional application No. 60/614,683, filed on Sep. 30, 2004. Provisional application No. 60/614,764, filed on Sep. 30, 2004.

**Publication Classification**

(51) **Int. Cl.**  
**A61B 5/00** (2006.01)  
(52) **U.S. Cl.** ..... **600/300**

(57) **ABSTRACT**

Systems and methods for minimizing or eliminating transient non-glucose related signal noise due to non-glucose rate limiting phenomenon such as interfering species, ischemia, pH changes, temperatures changes, known or unknown sources of mechanical, electrical and/or biochemical noise, and the like. The system monitors a data stream from a glucose sensor and detects signal artifacts that have higher amplitude than electronic or diffusion-related system noise. The system processes some or the entire data stream continually or intermittently based at least in part on whether the signal artifact event has occurred.

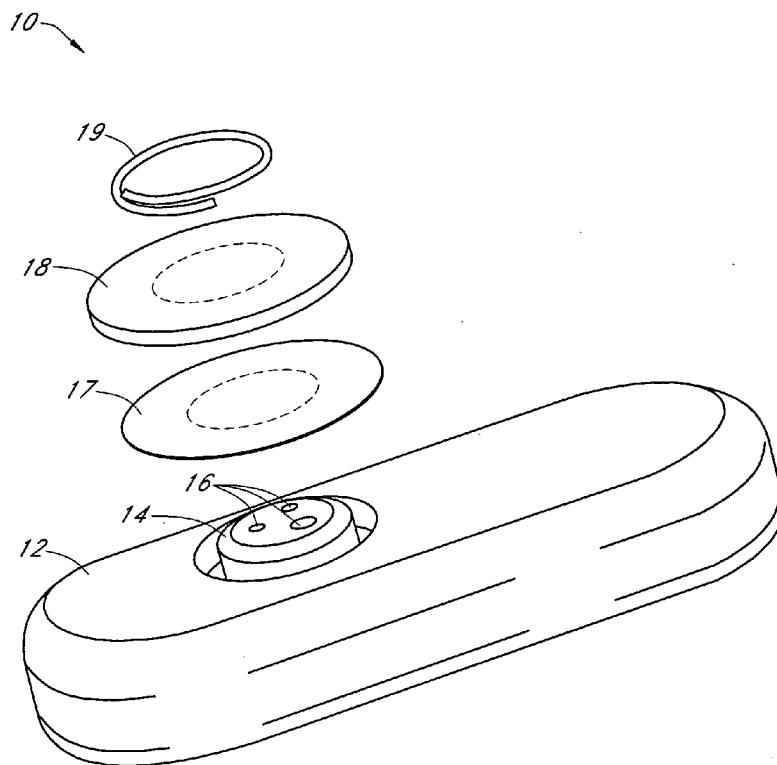

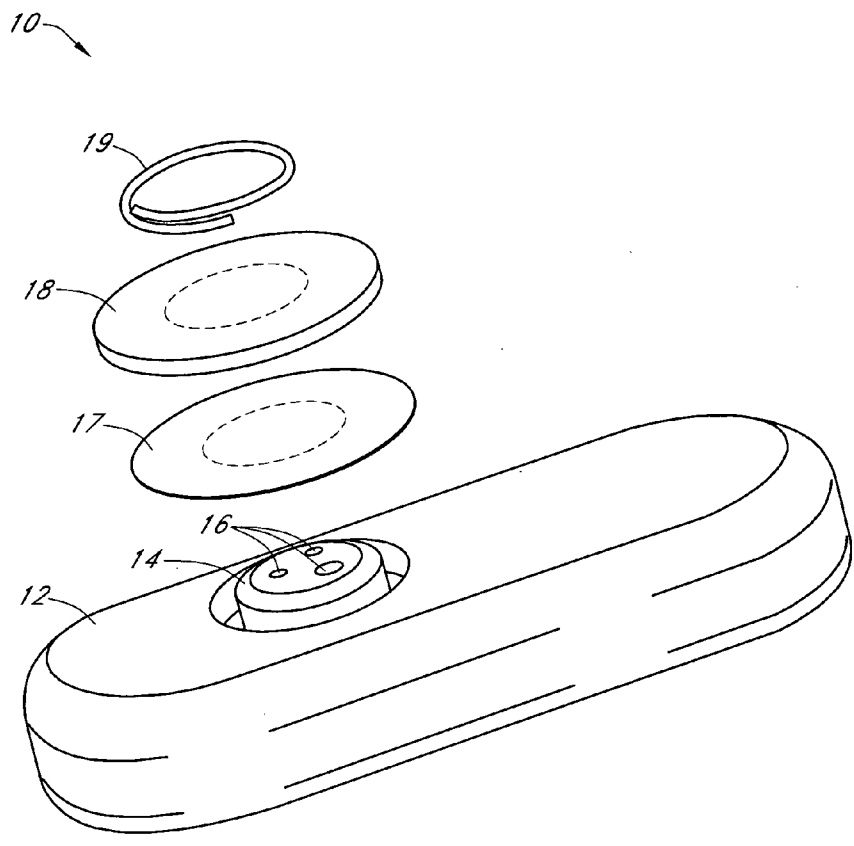

FIG. 1A

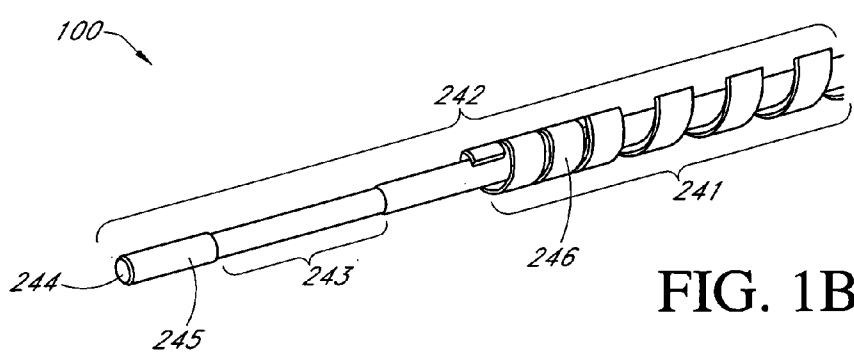

FIG. 1B

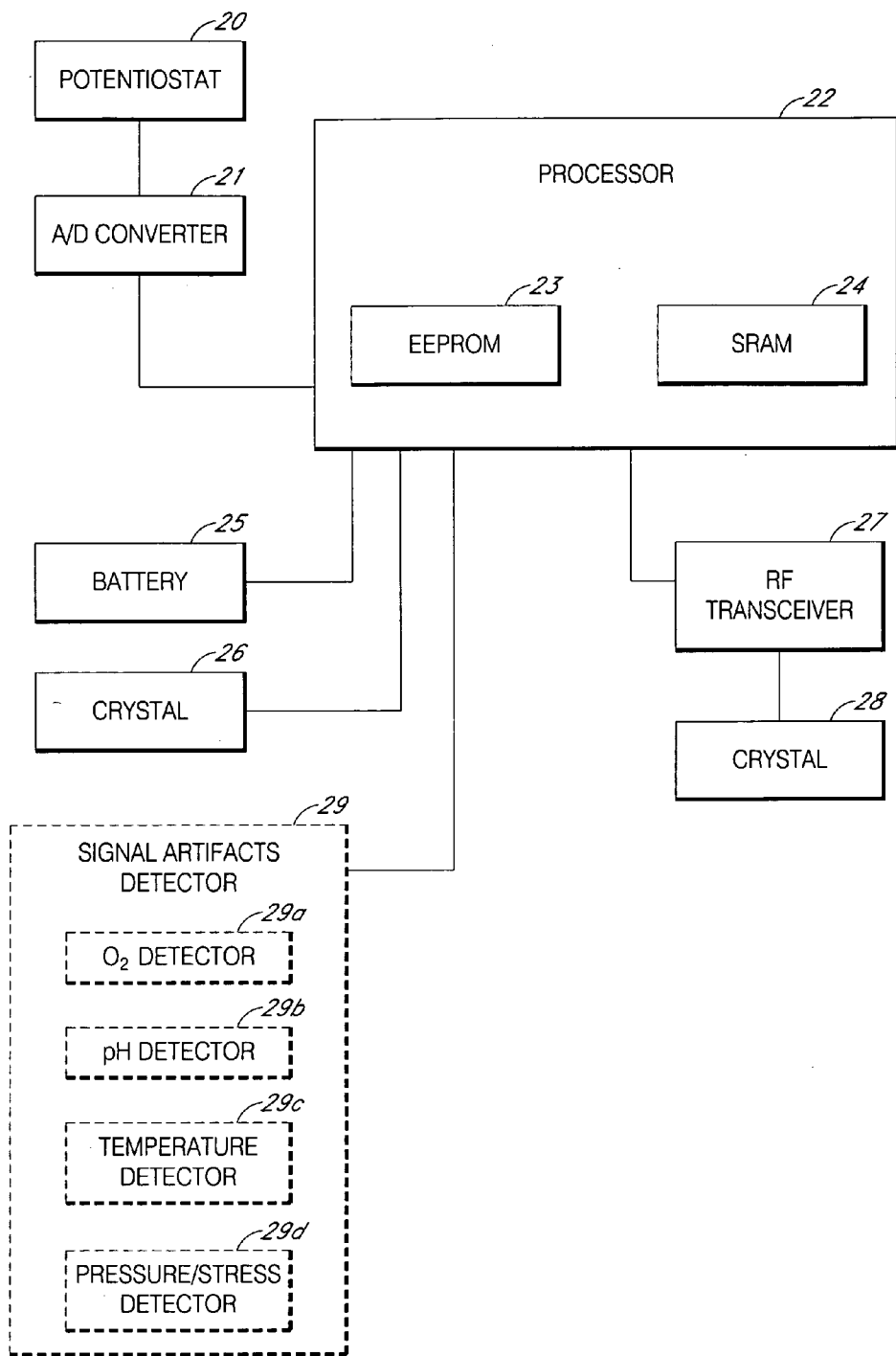

FIG. 2

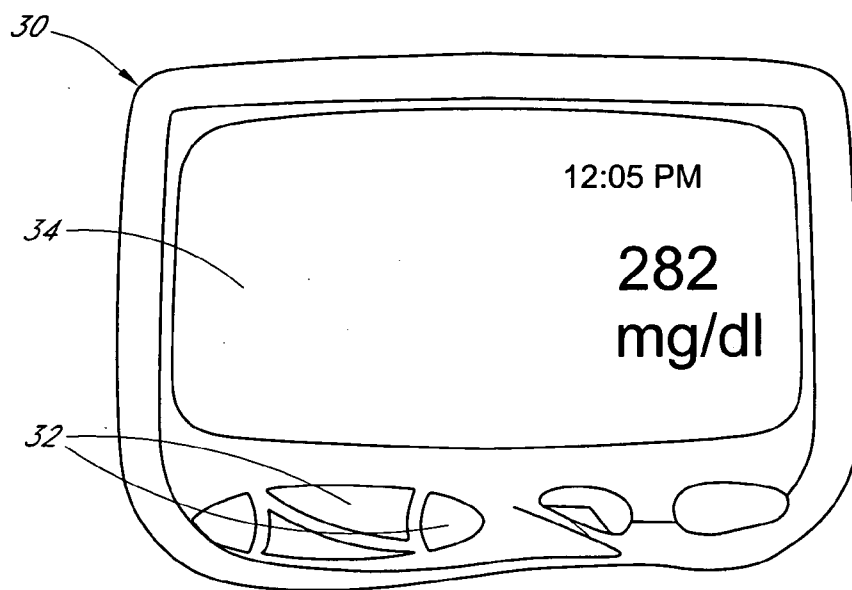

FIG. 3A

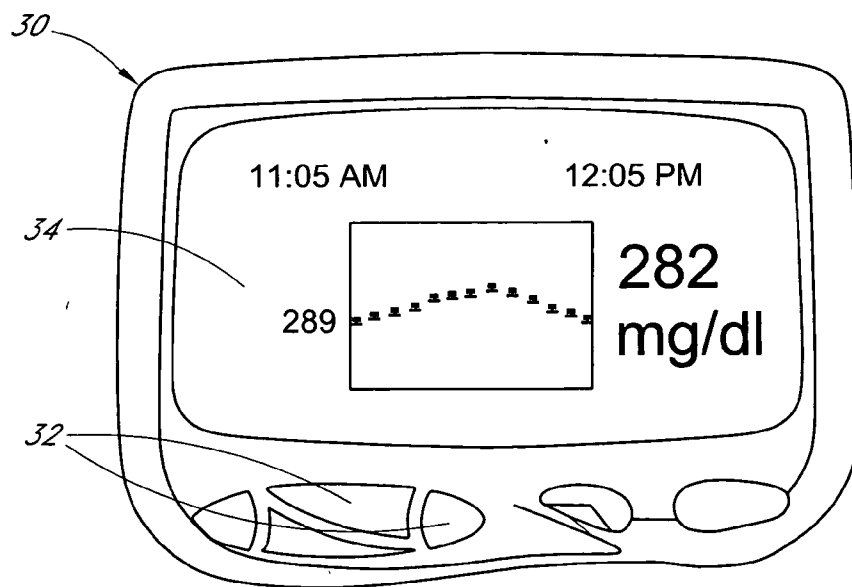

FIG. 3B

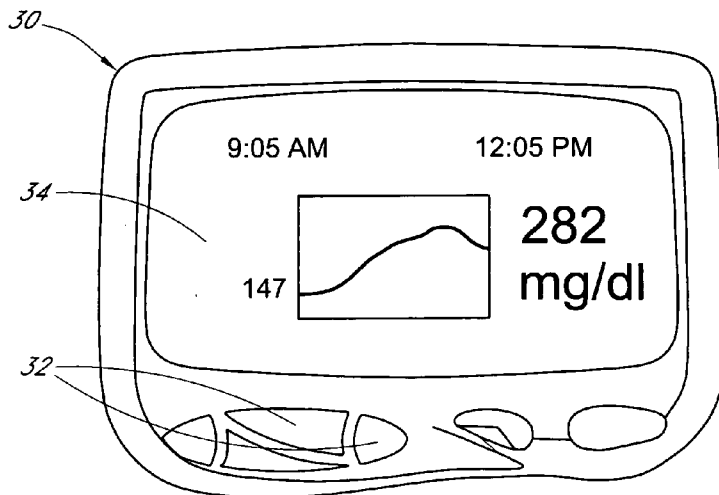

FIG. 3C

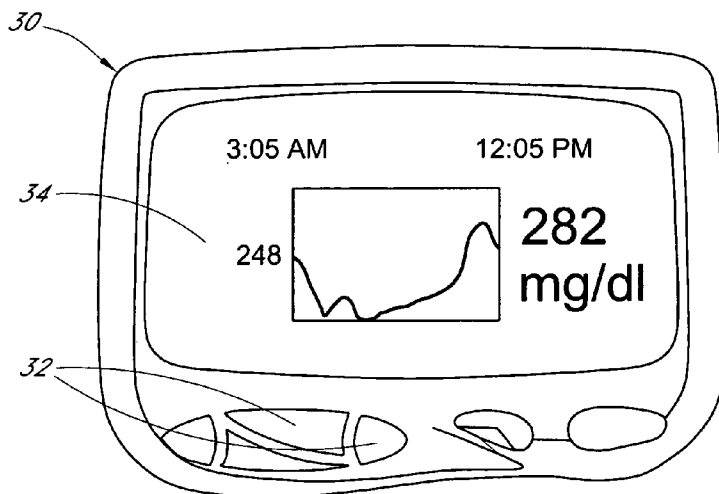

FIG. 3D

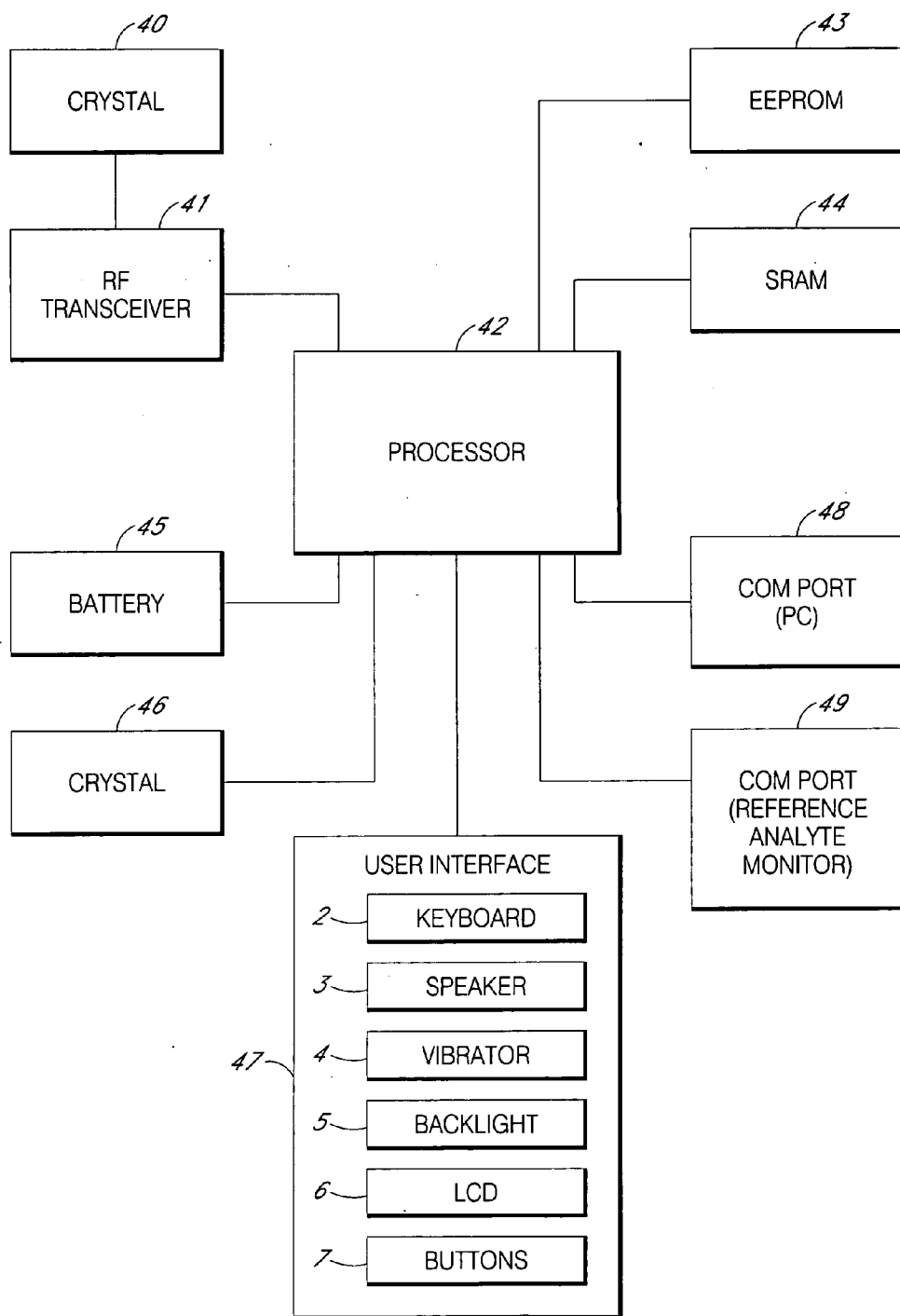

FIG. 4A

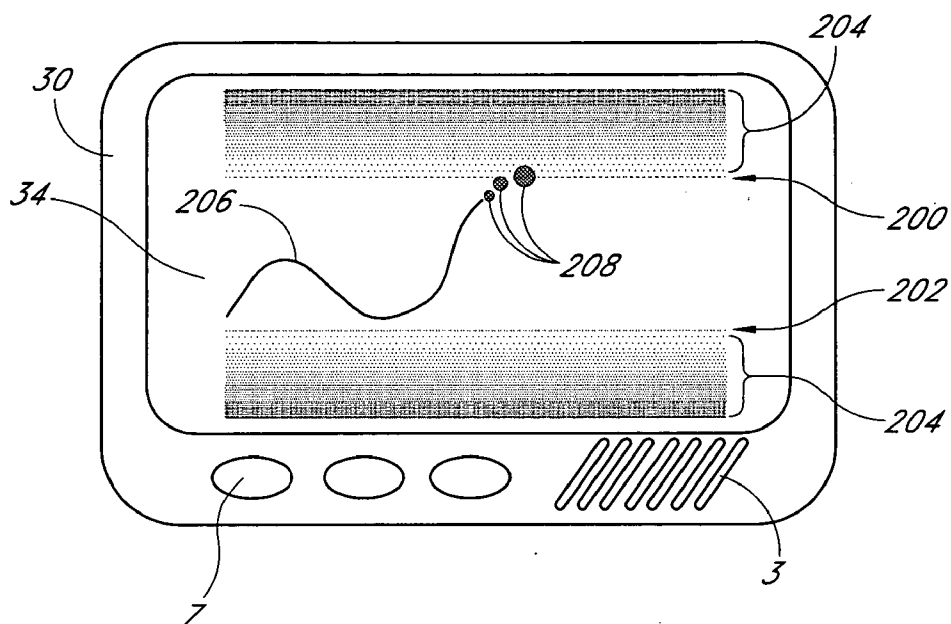

FIG. 4B

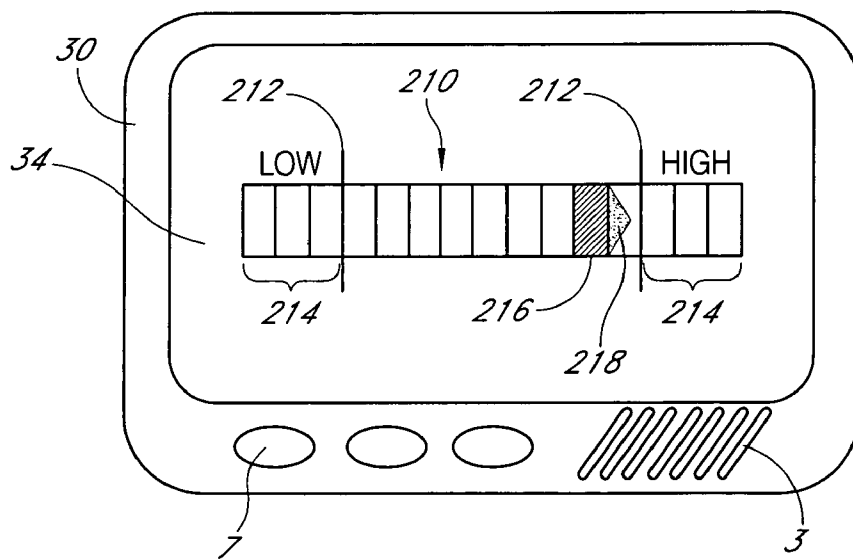

FIG. 4C

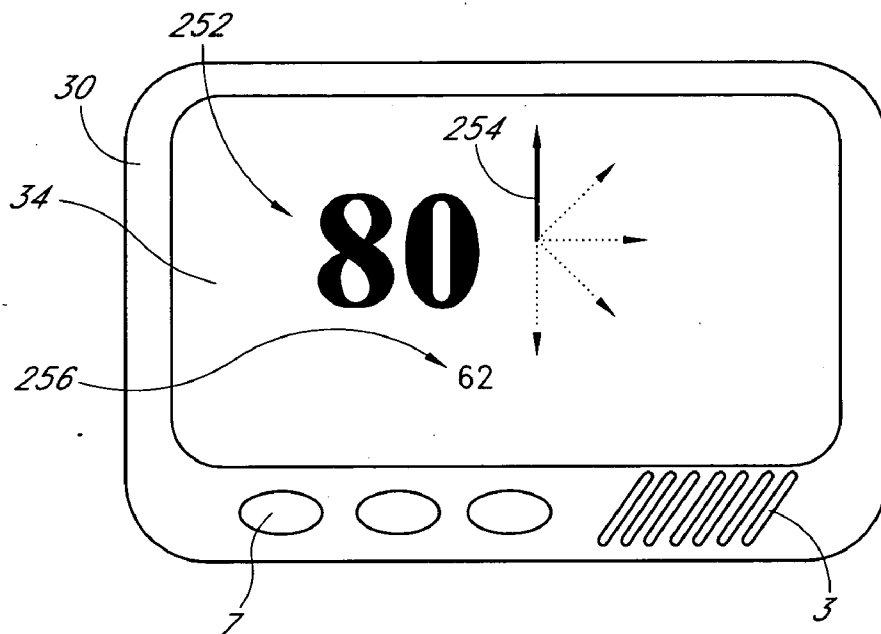

FIG. 4D



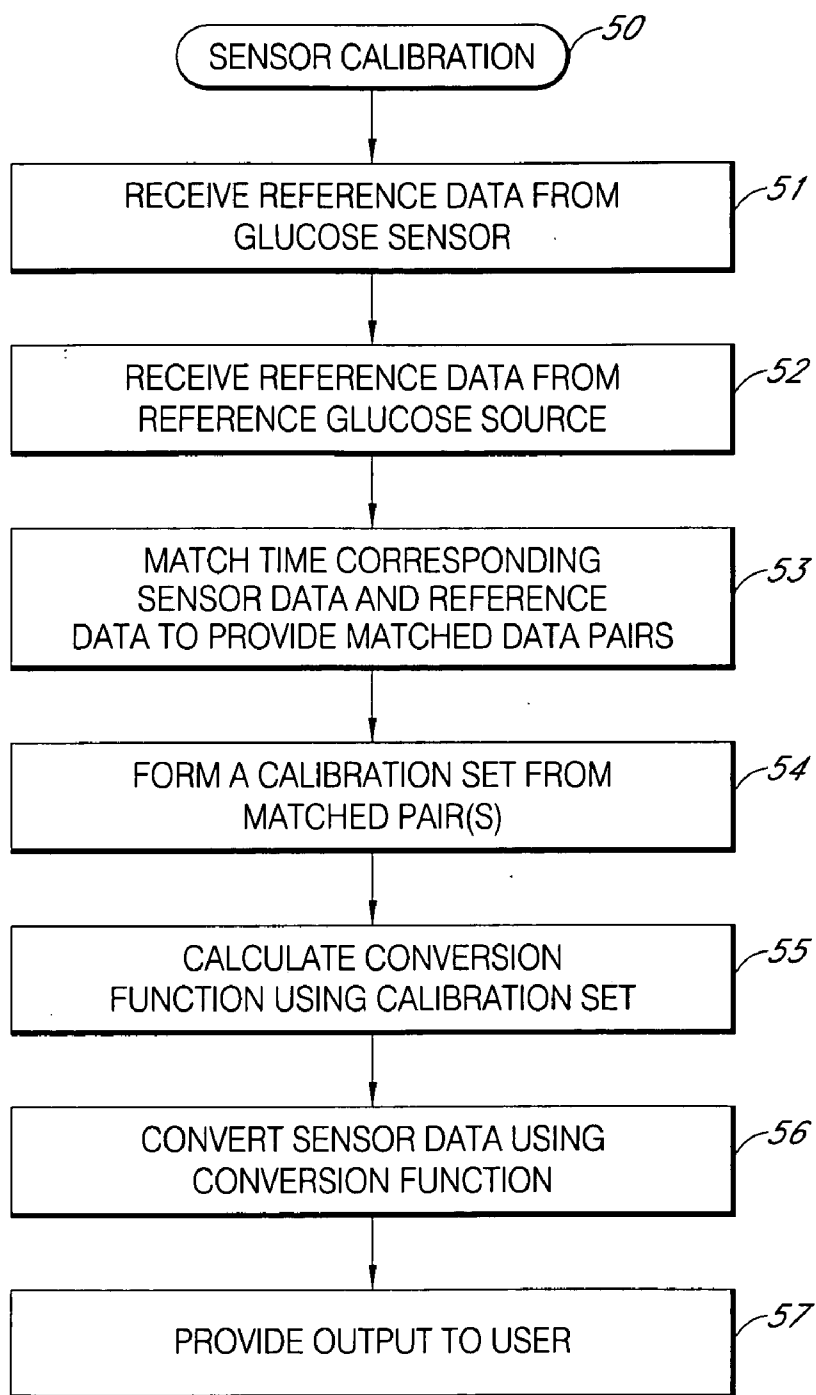

FIG. 5

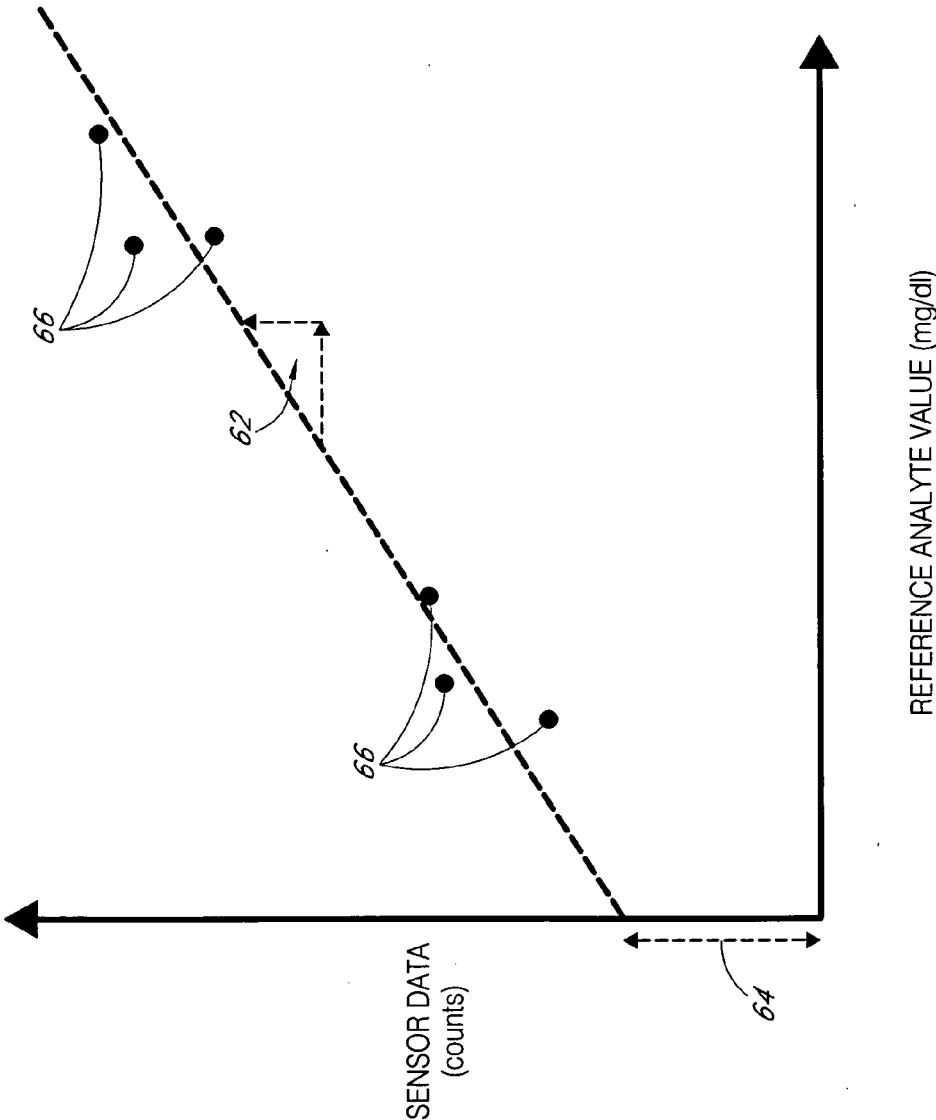

FIG. 6

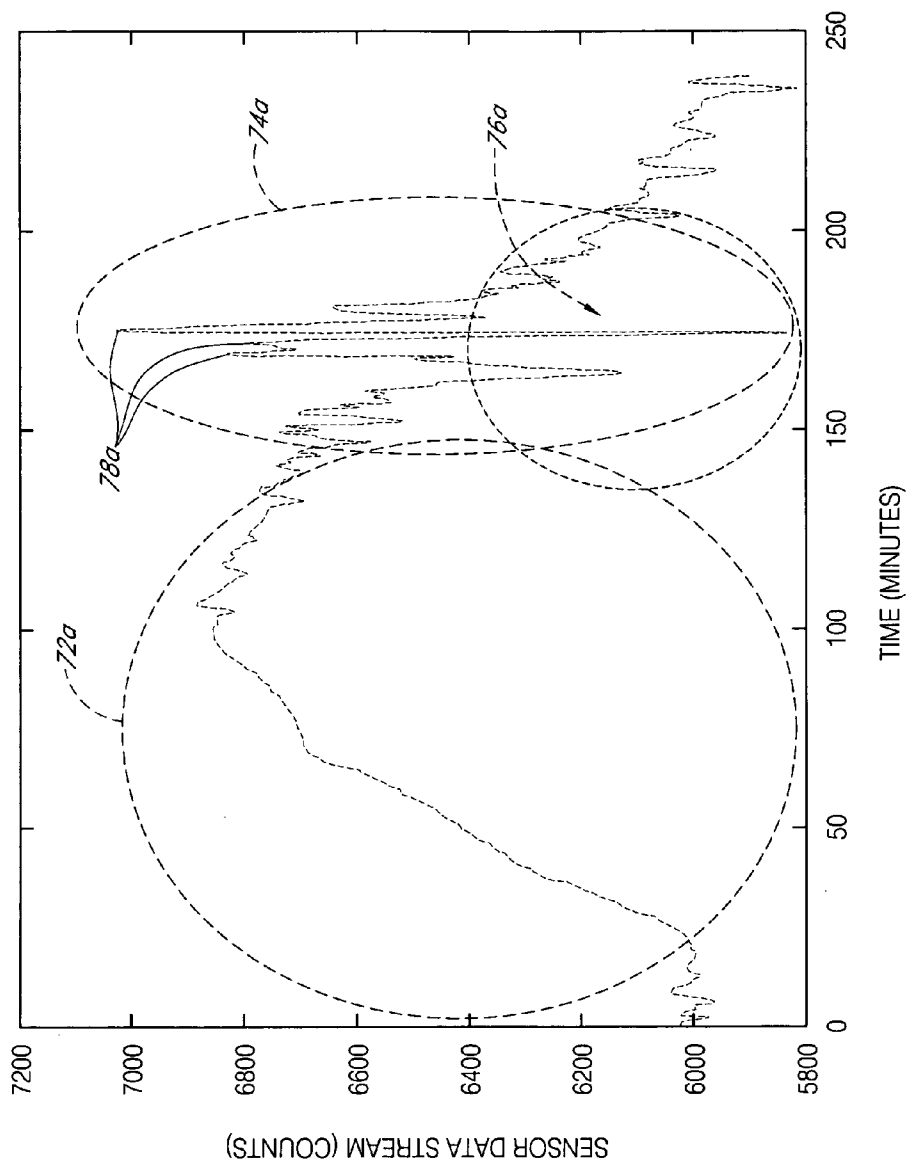

FIG. 7A

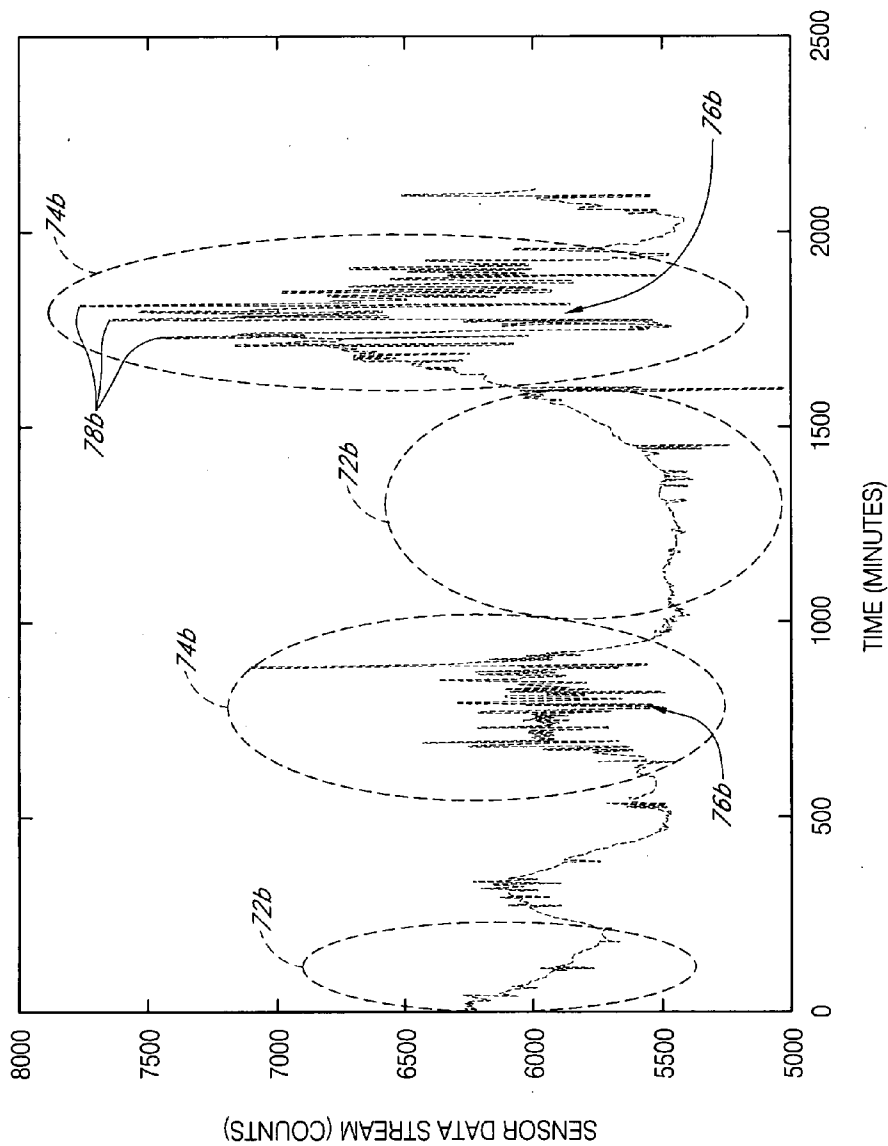

FIG. 7B

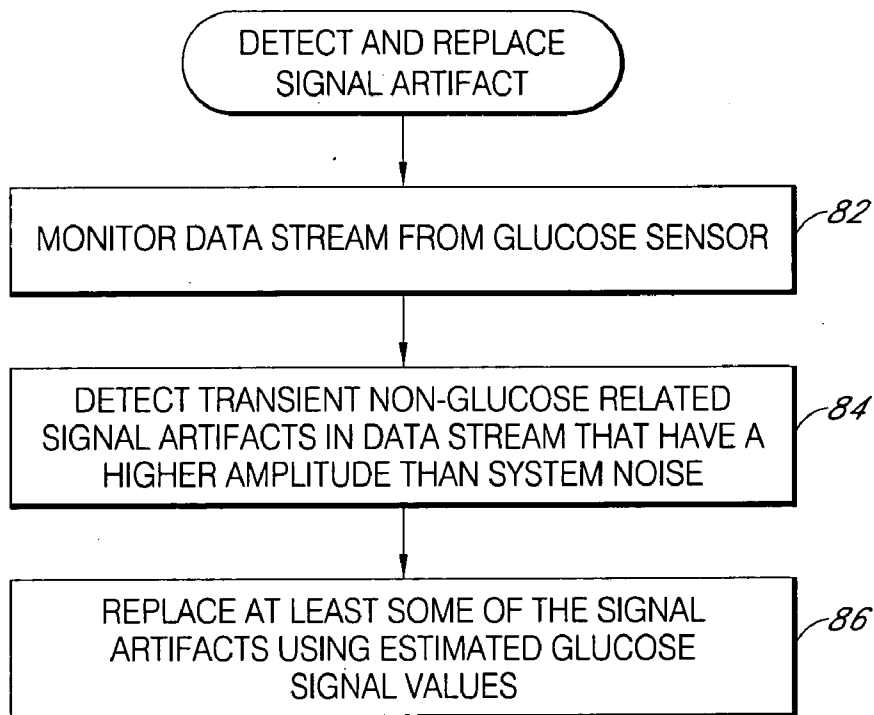

FIG. 8

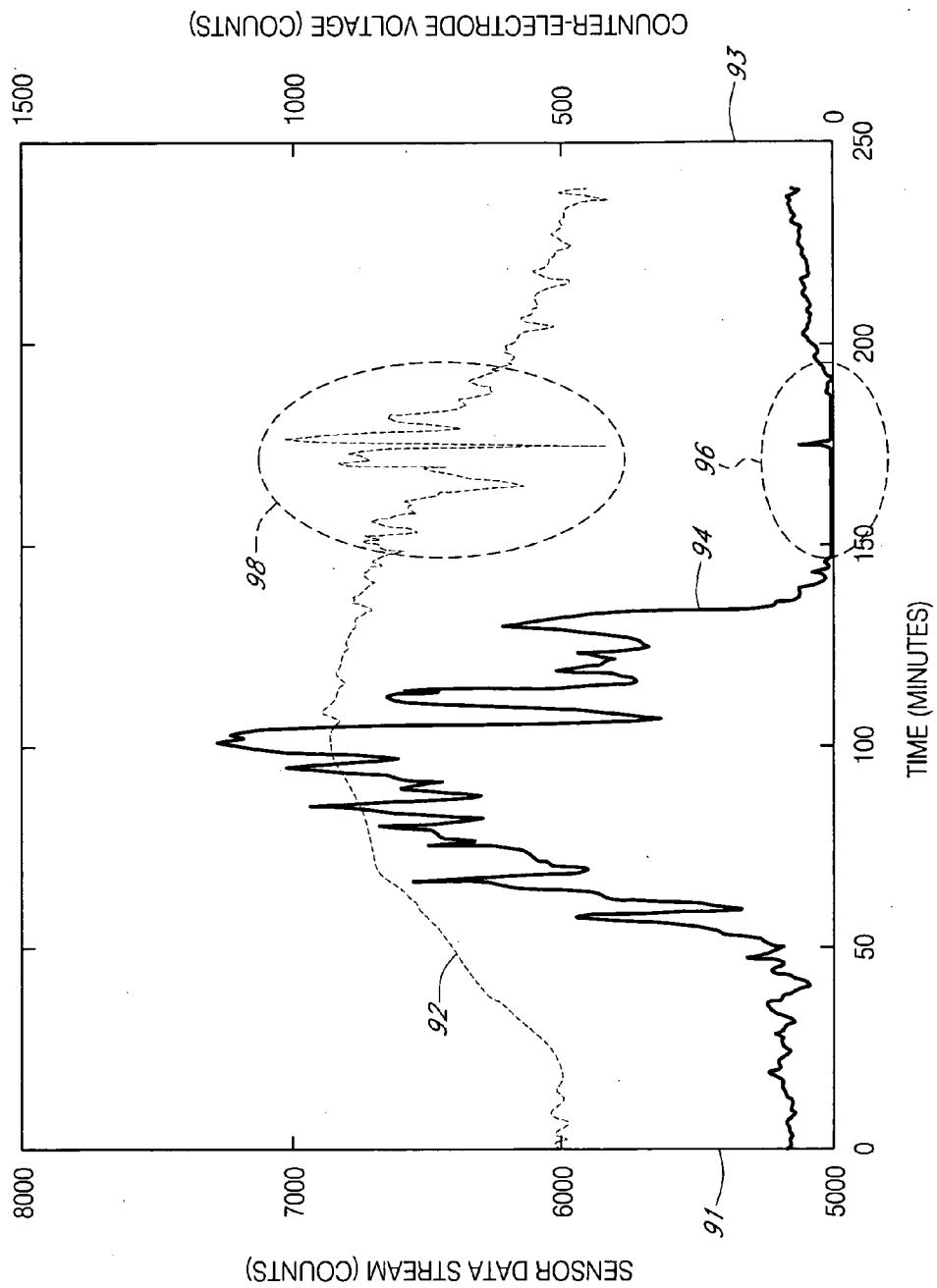

FIG. 9

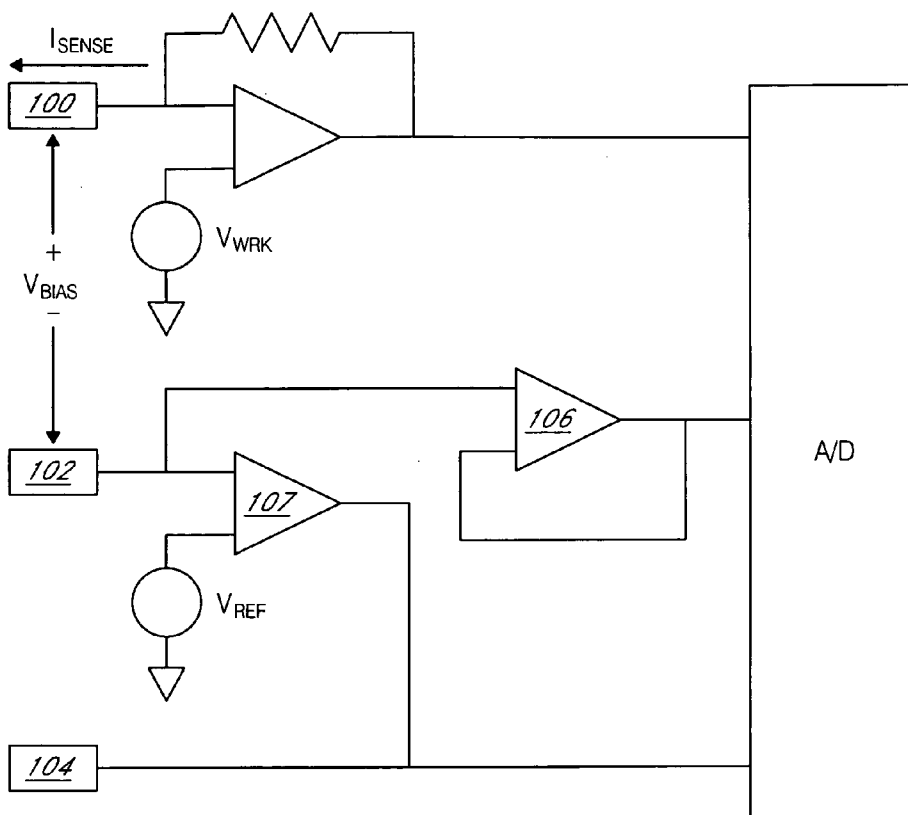

FIG. 10A

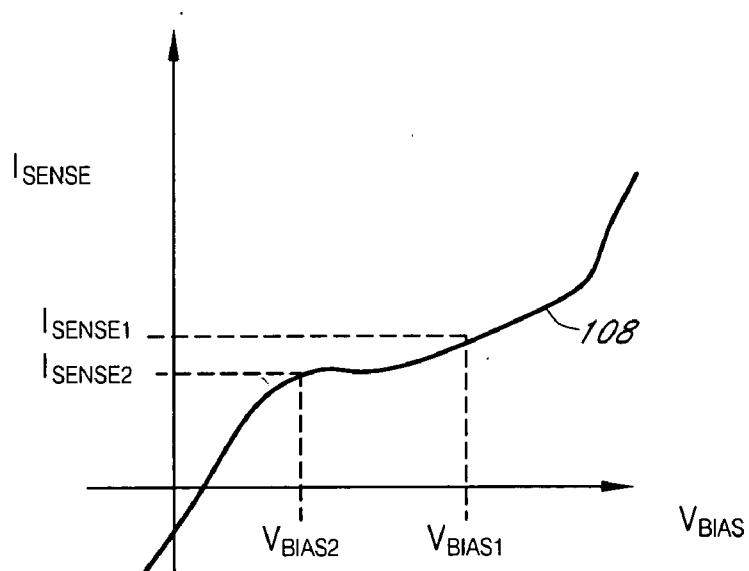

FIG. 10B

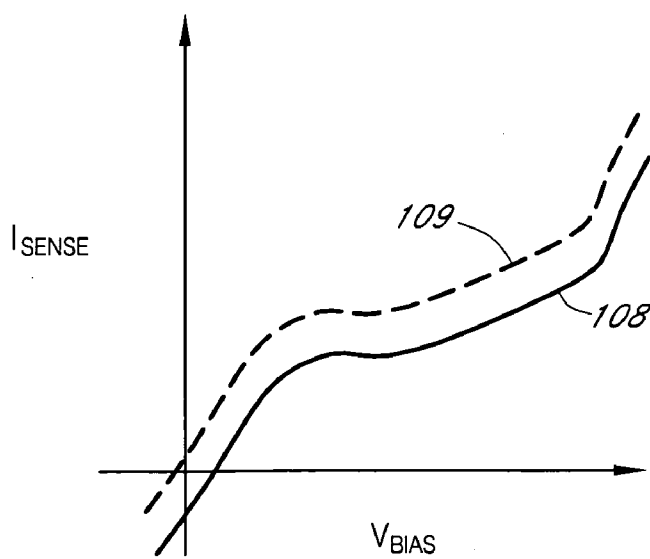

FIG. 10C



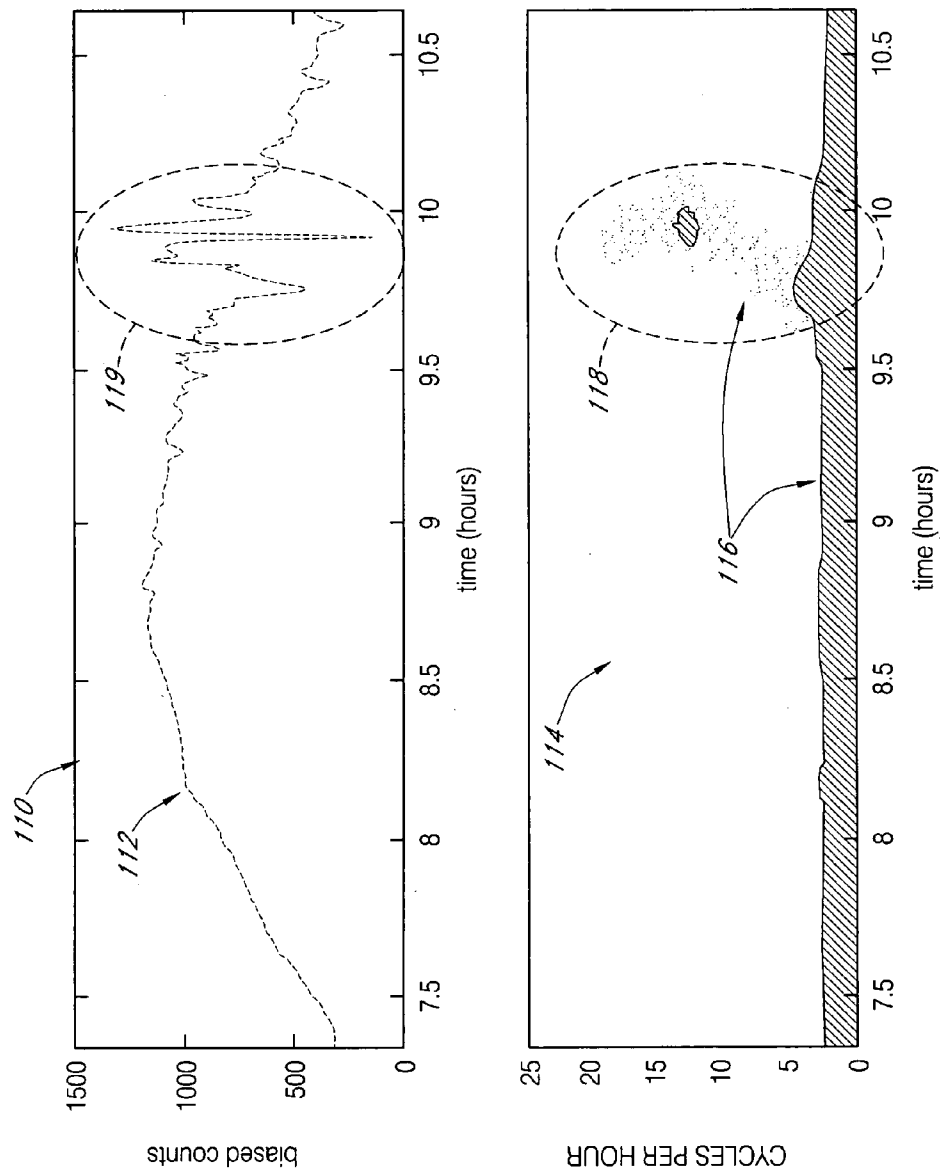

FIG. 11

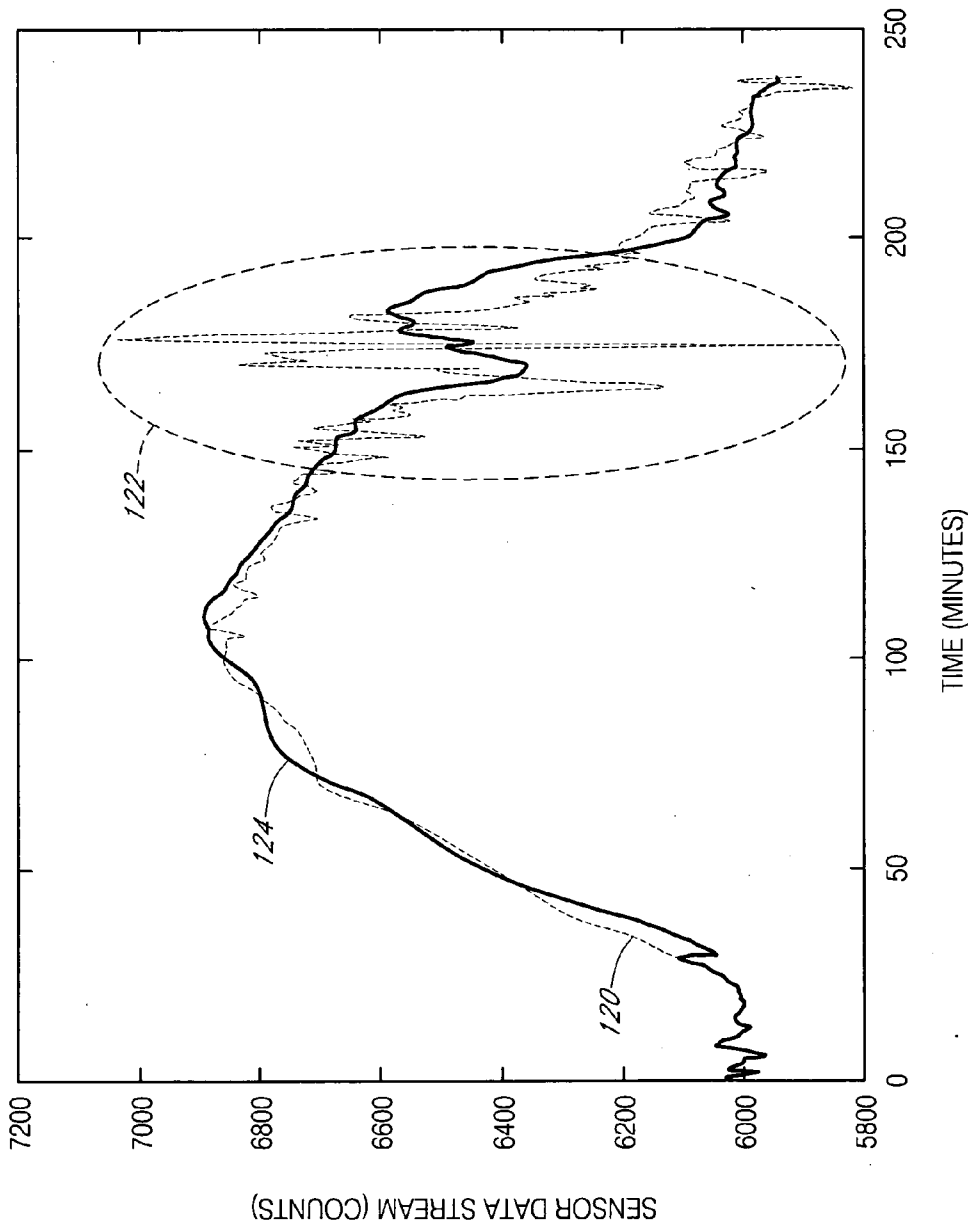

FIG. 12

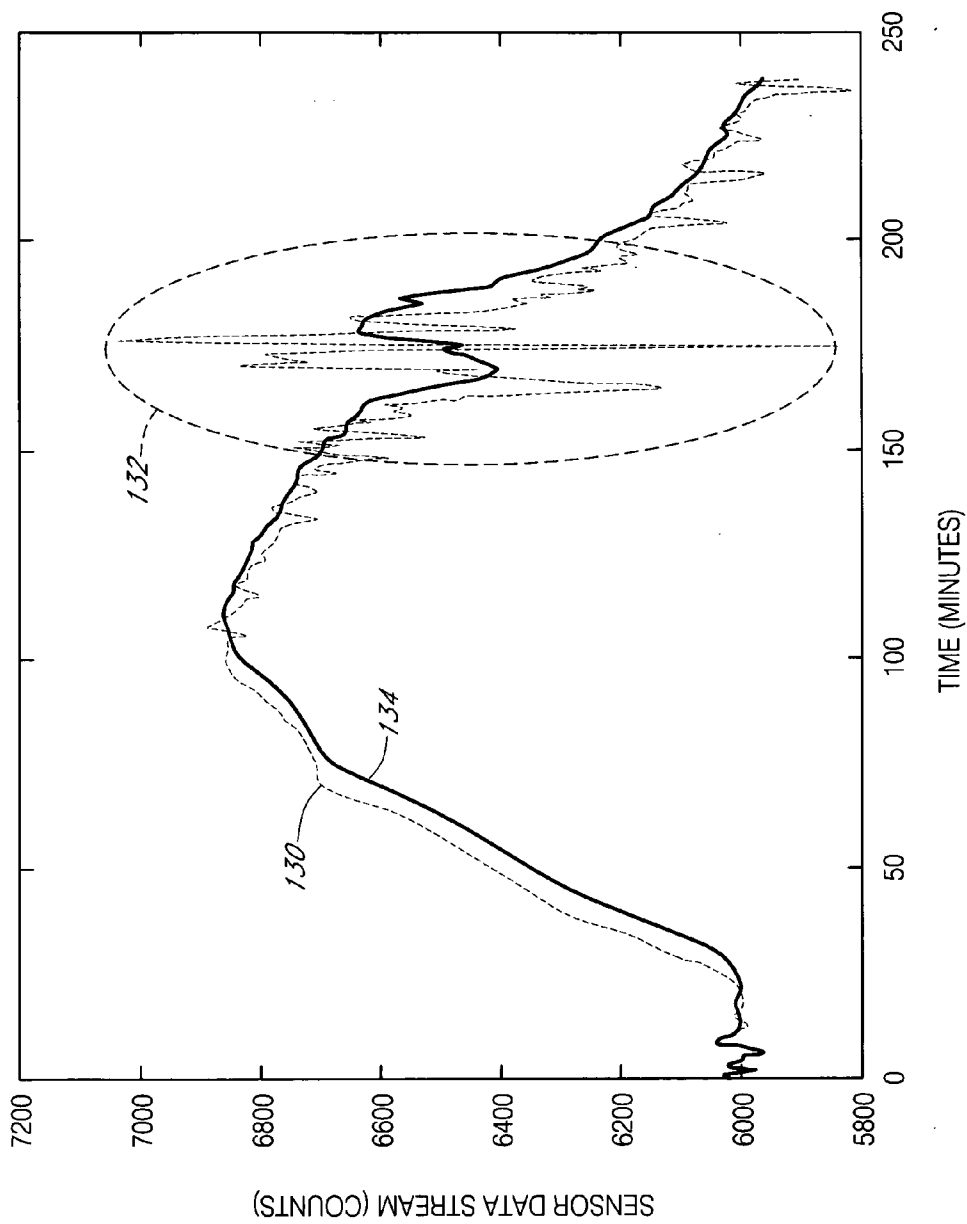

FIG. 13

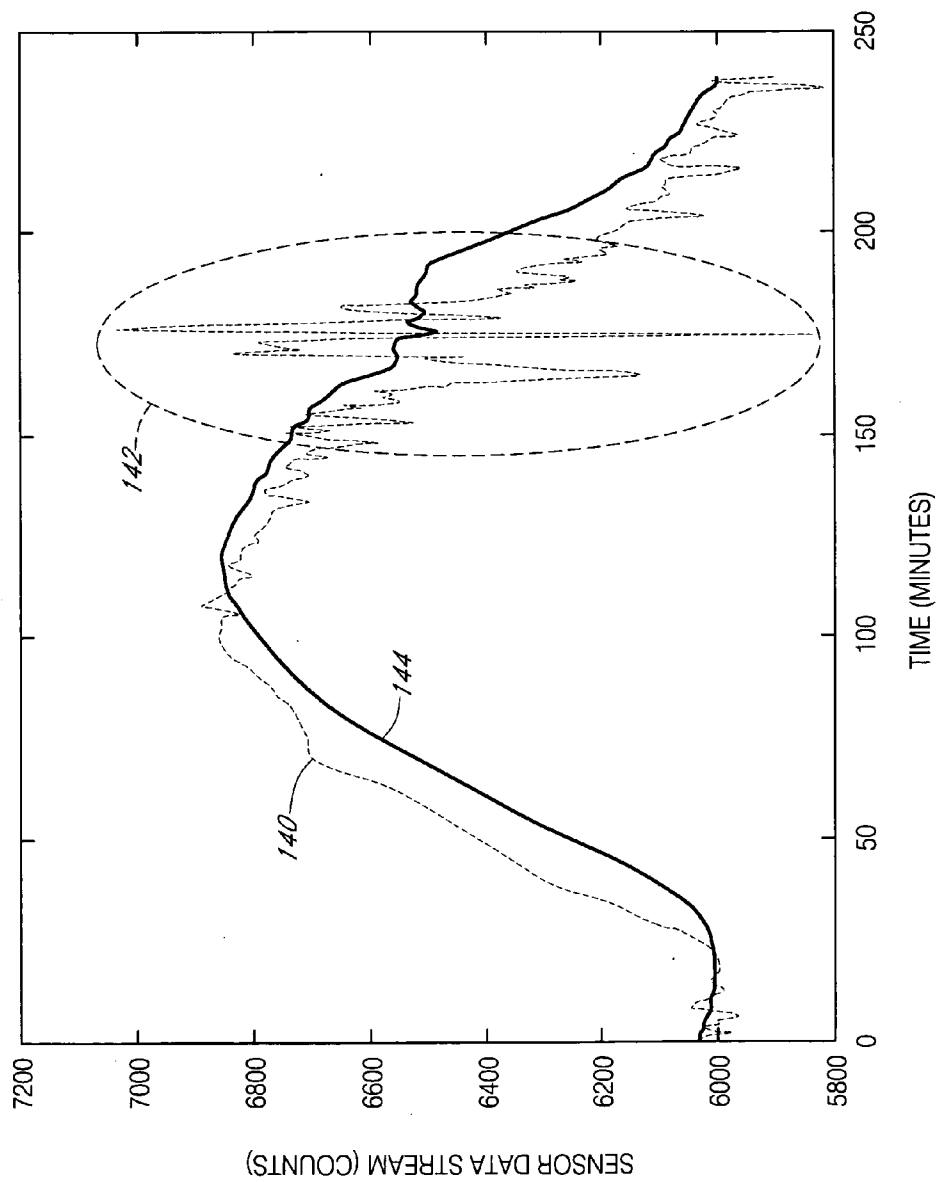

FIG. 14

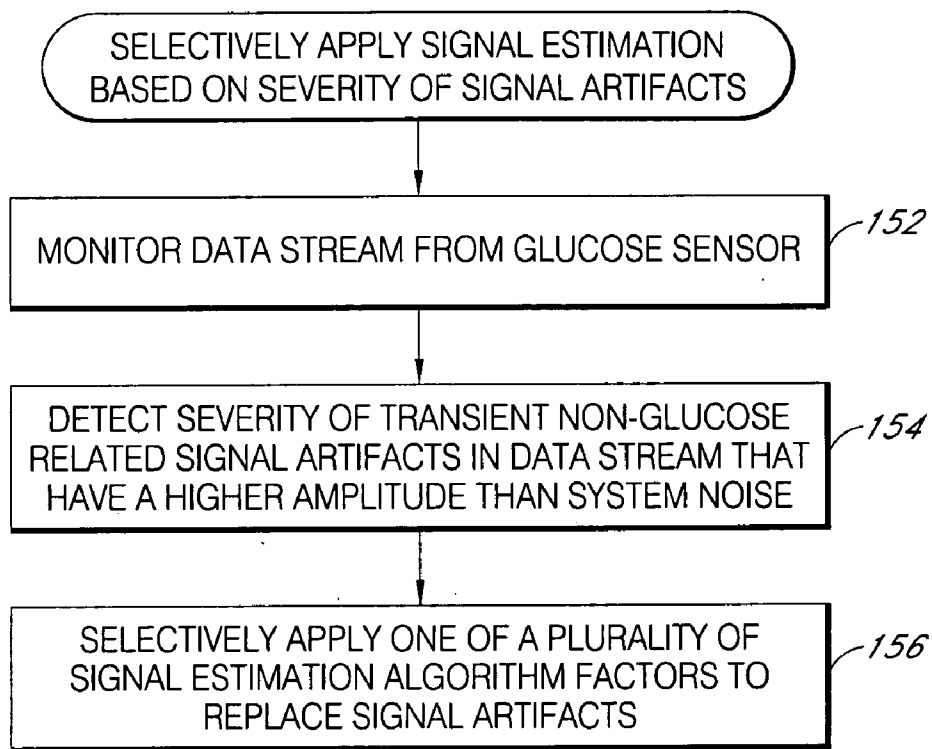

FIG. 15

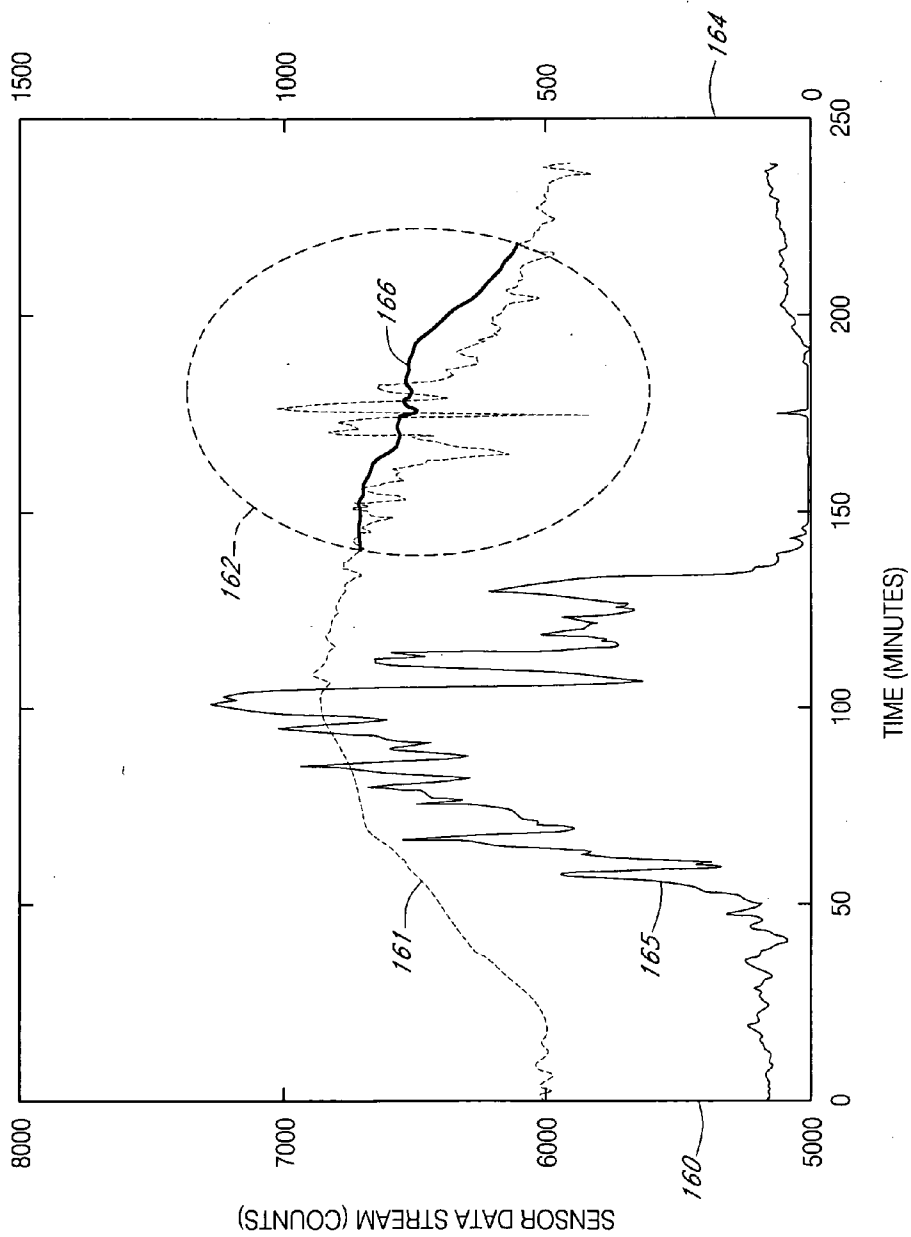

FIG. 16

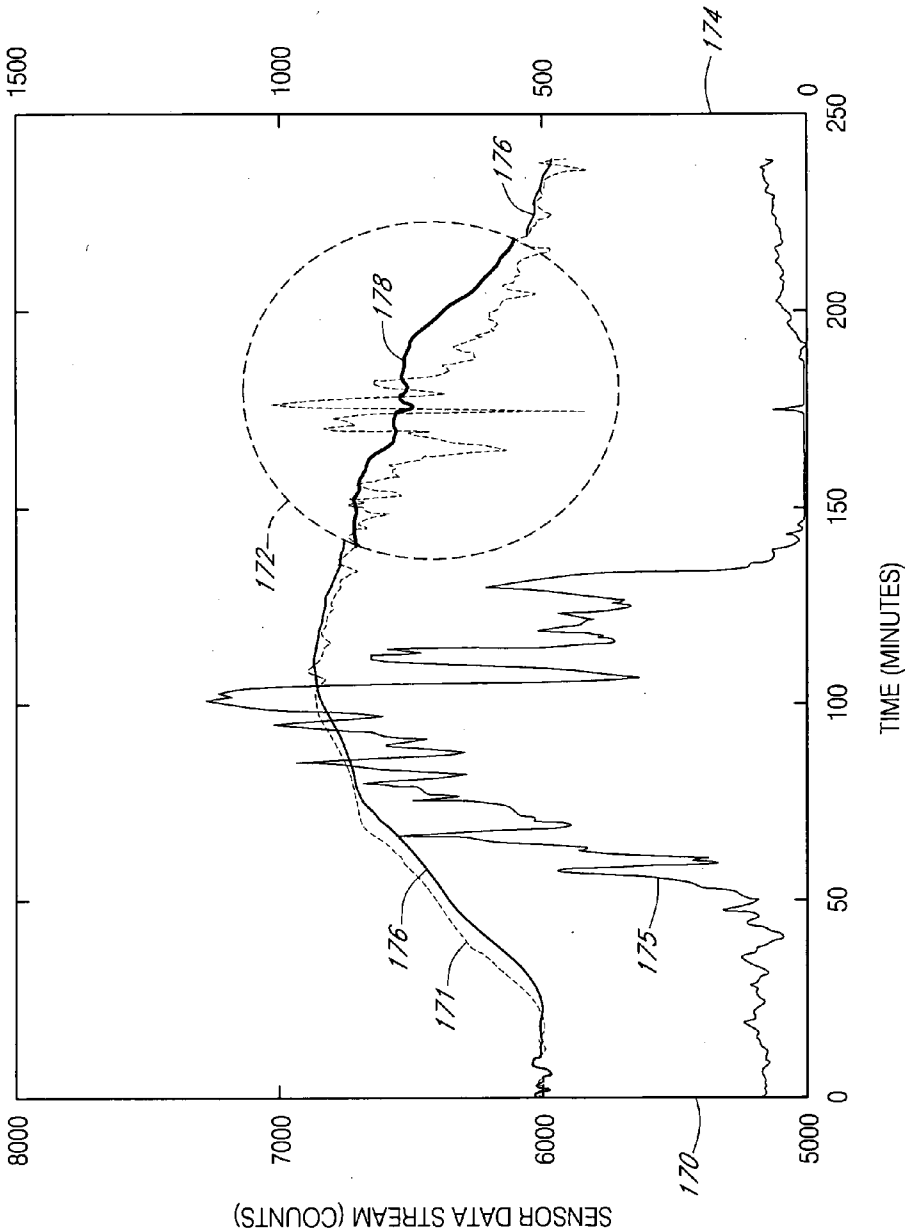

FIG. 17

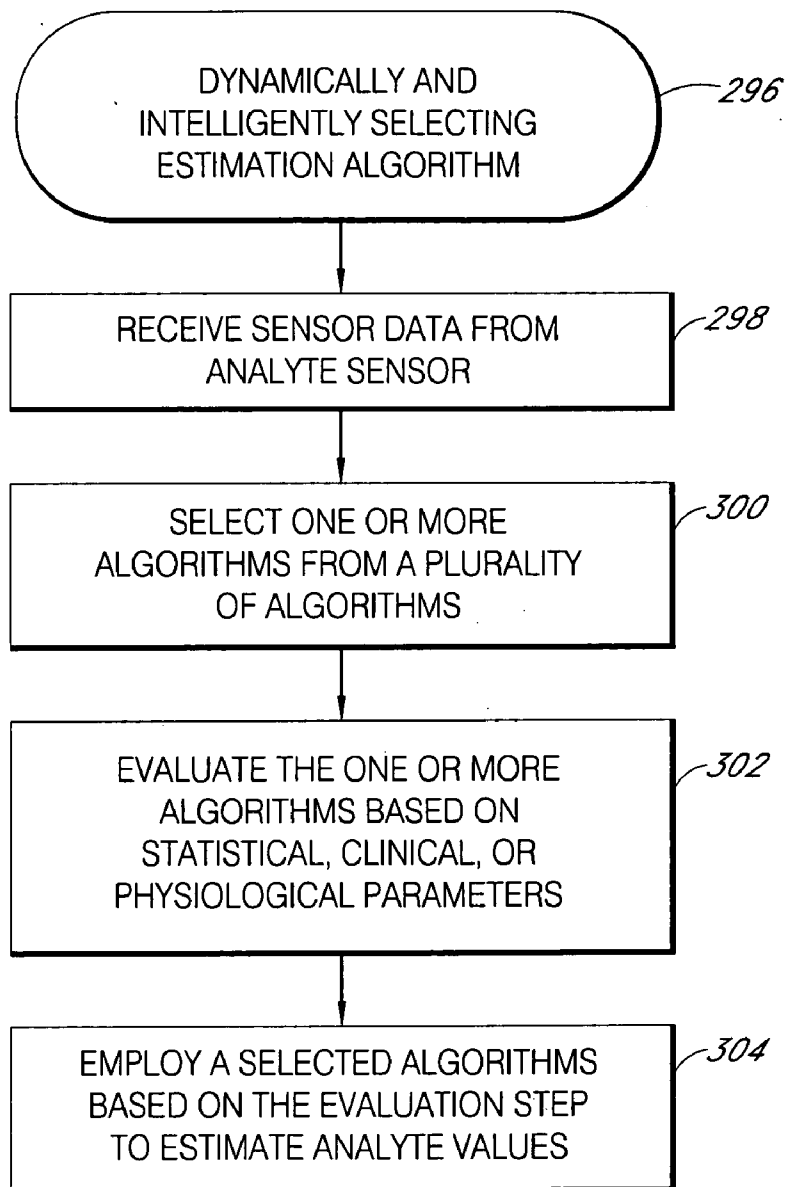

FIG. 18



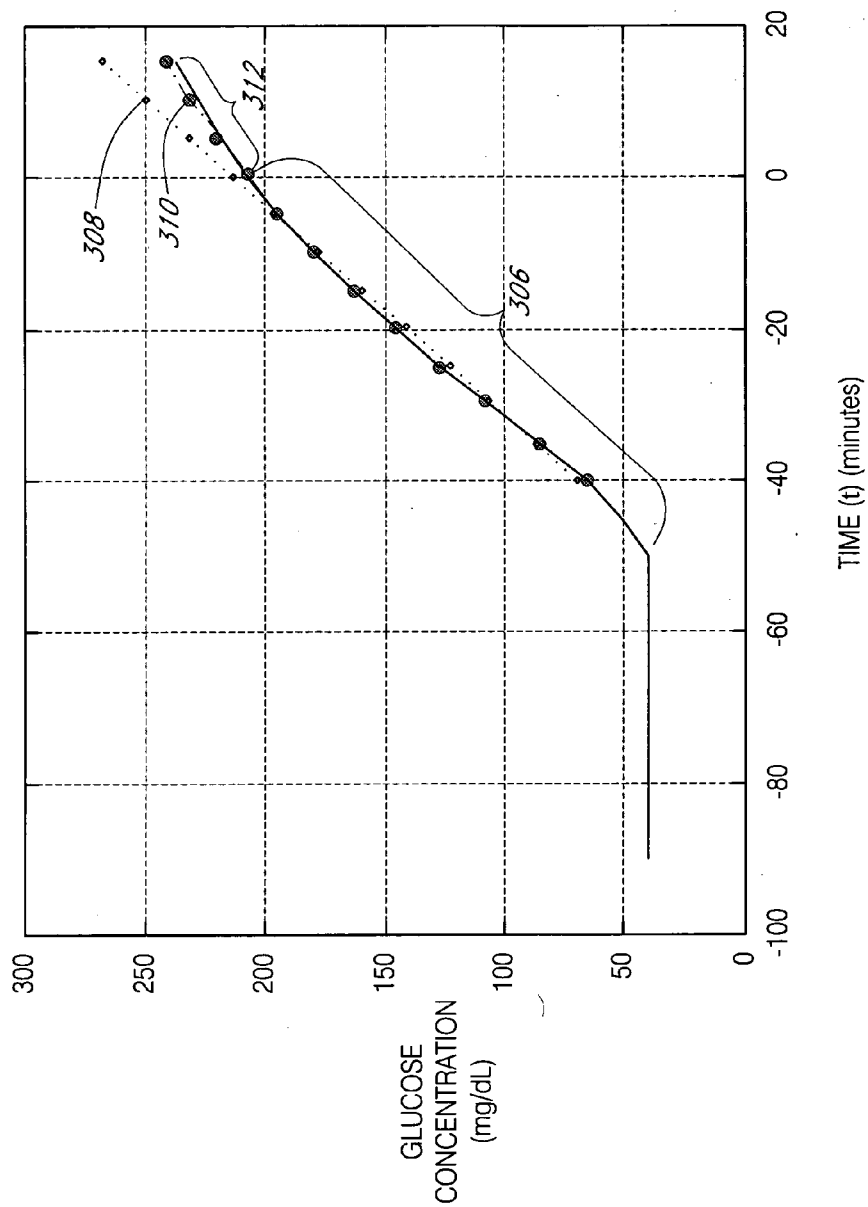

FIG. 19

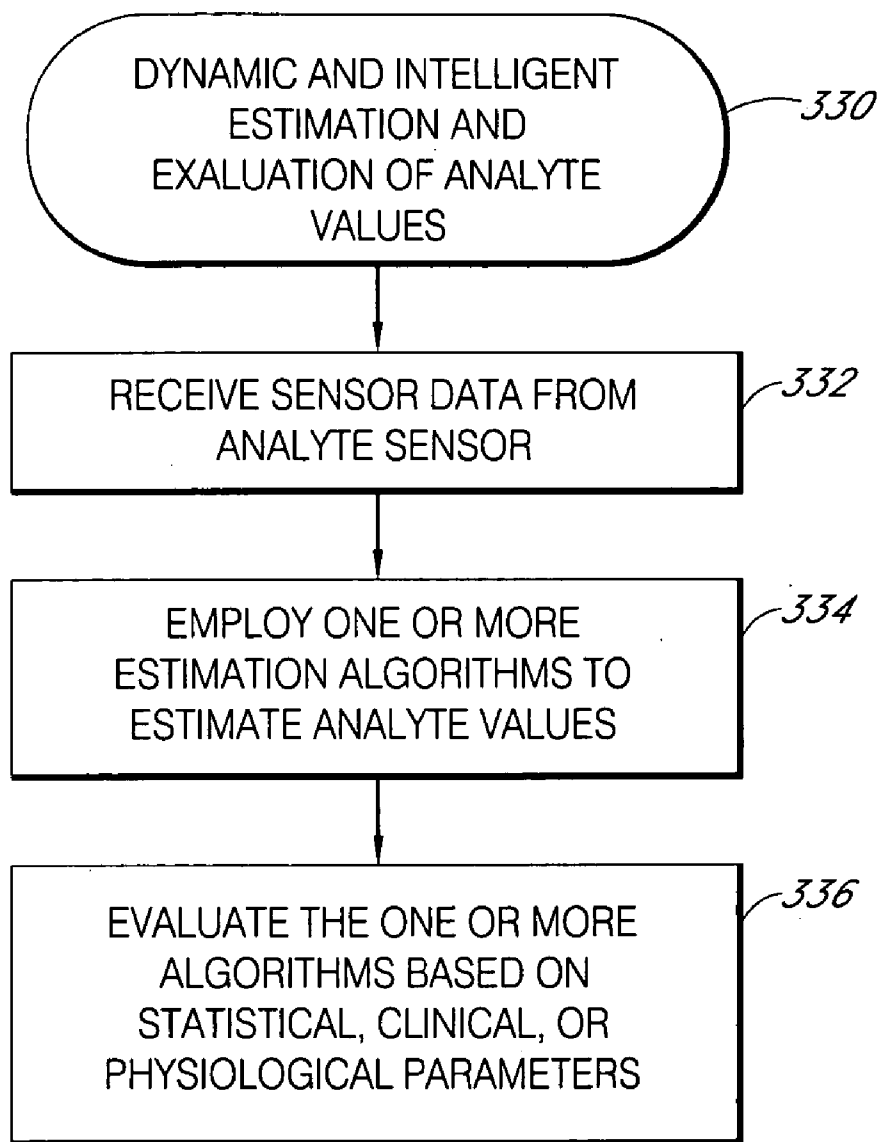

FIG. 20

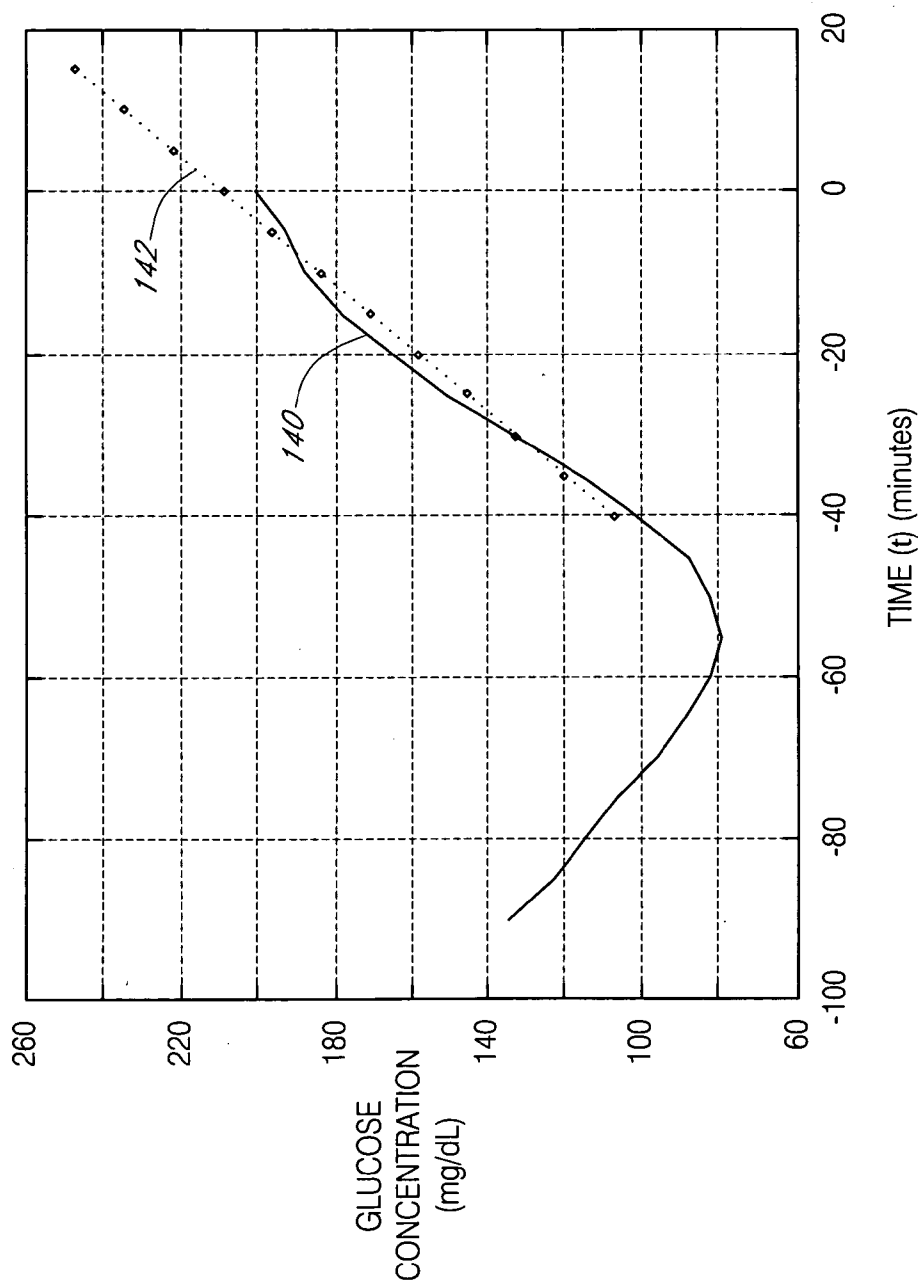

FIG. 21

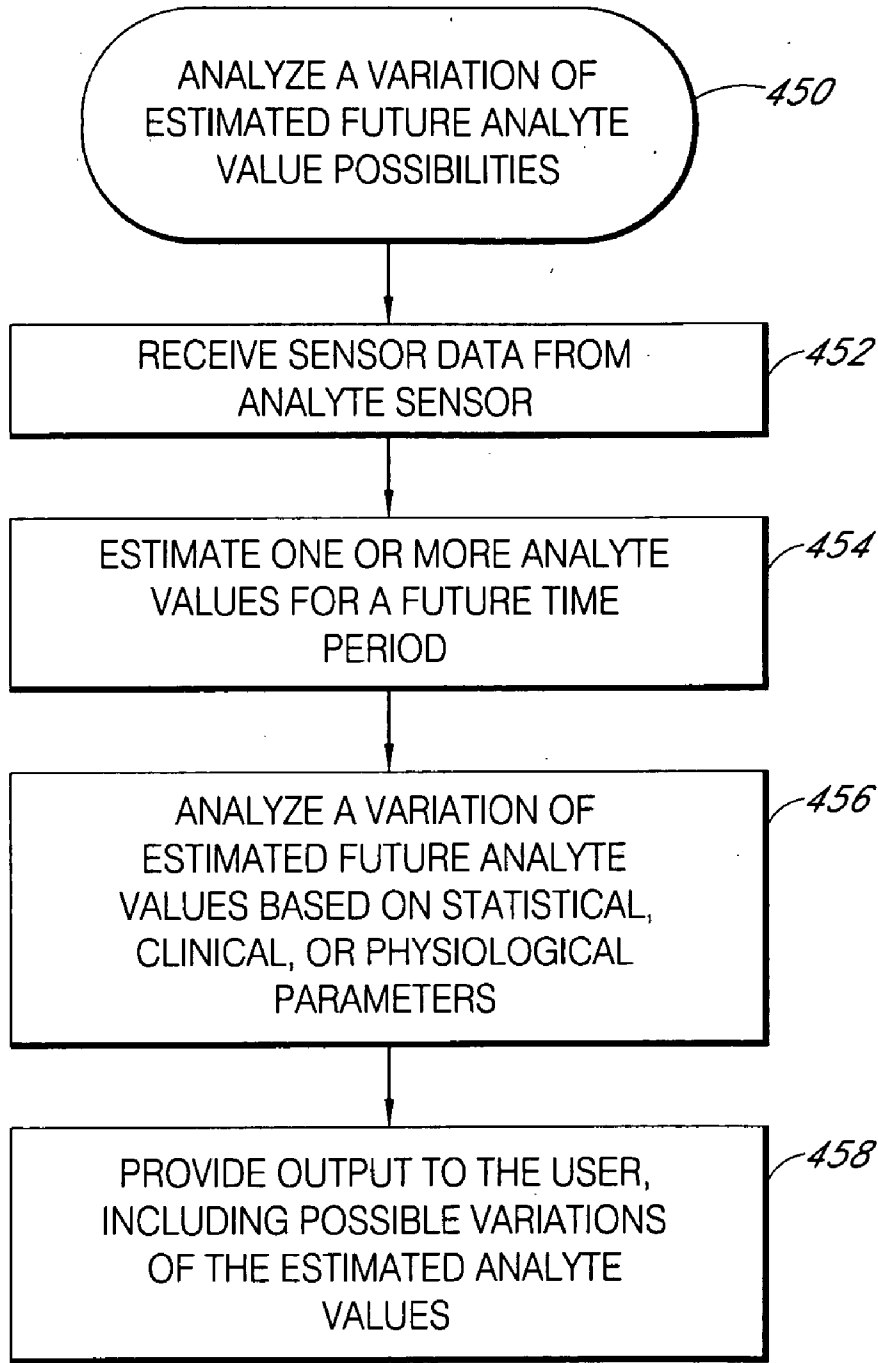

FIG. 22

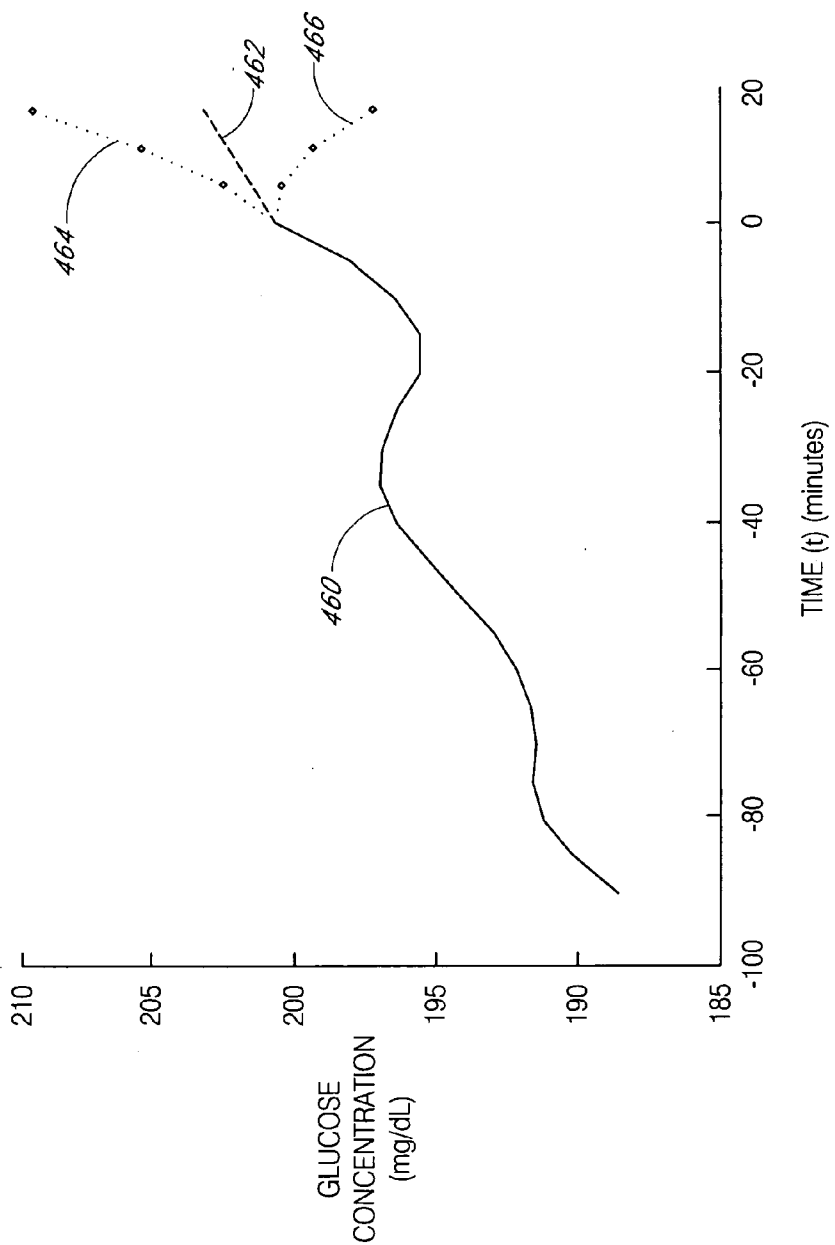

FIG. 23

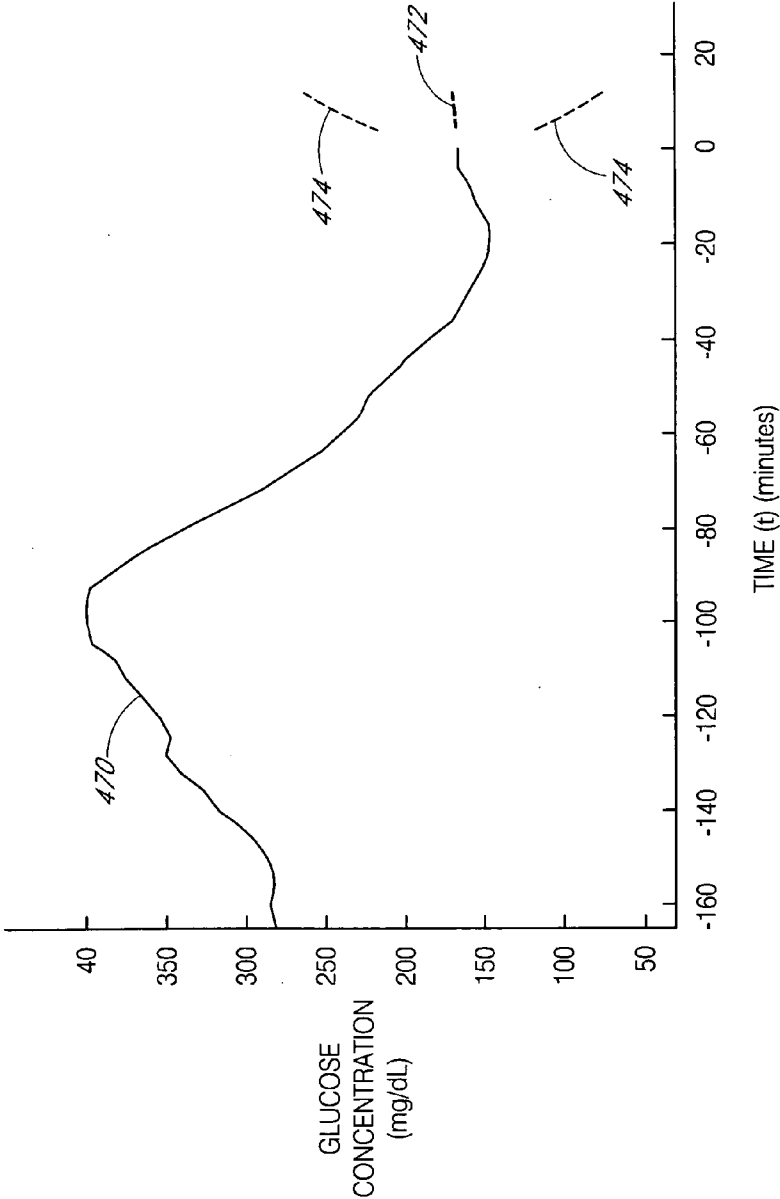

FIG. 24

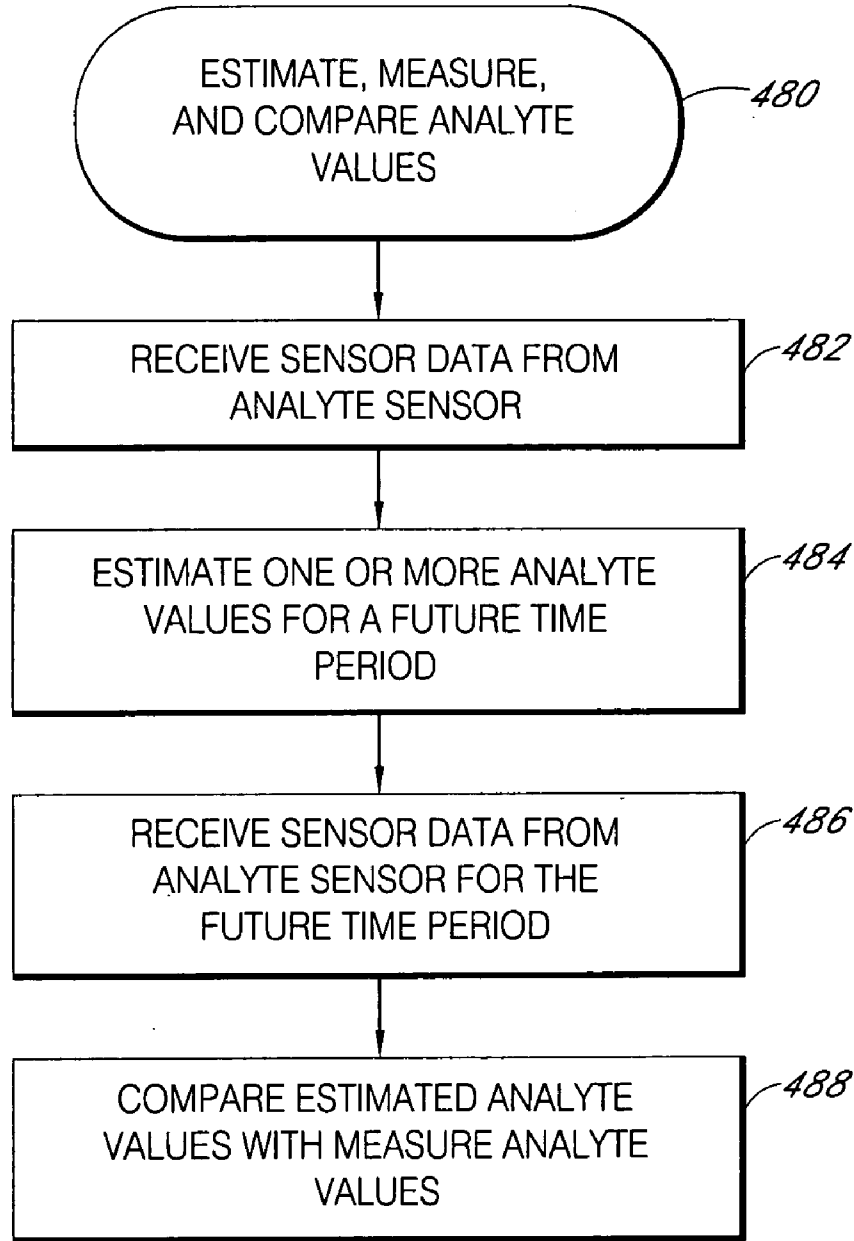

FIG. 25

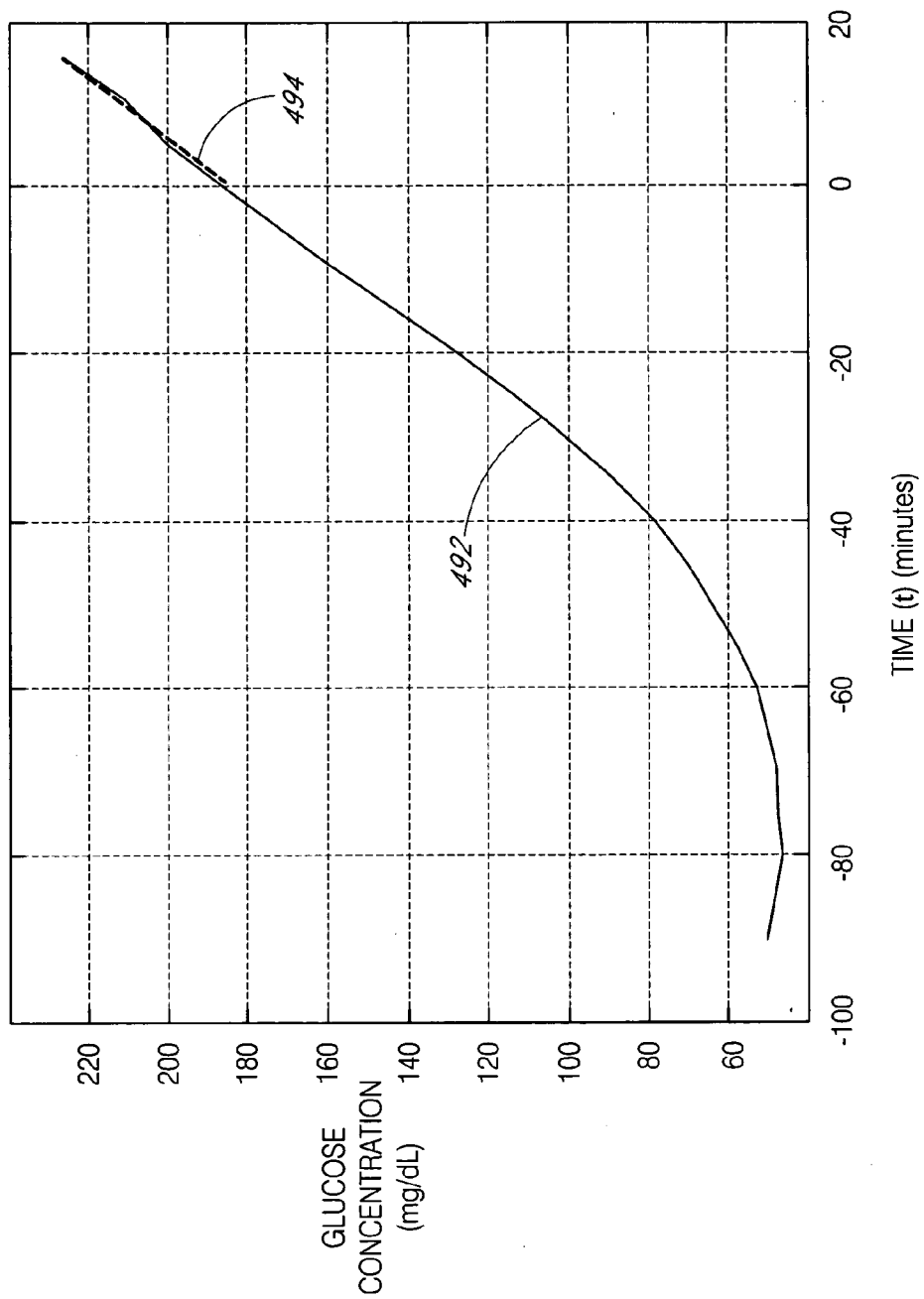

FIG. 26



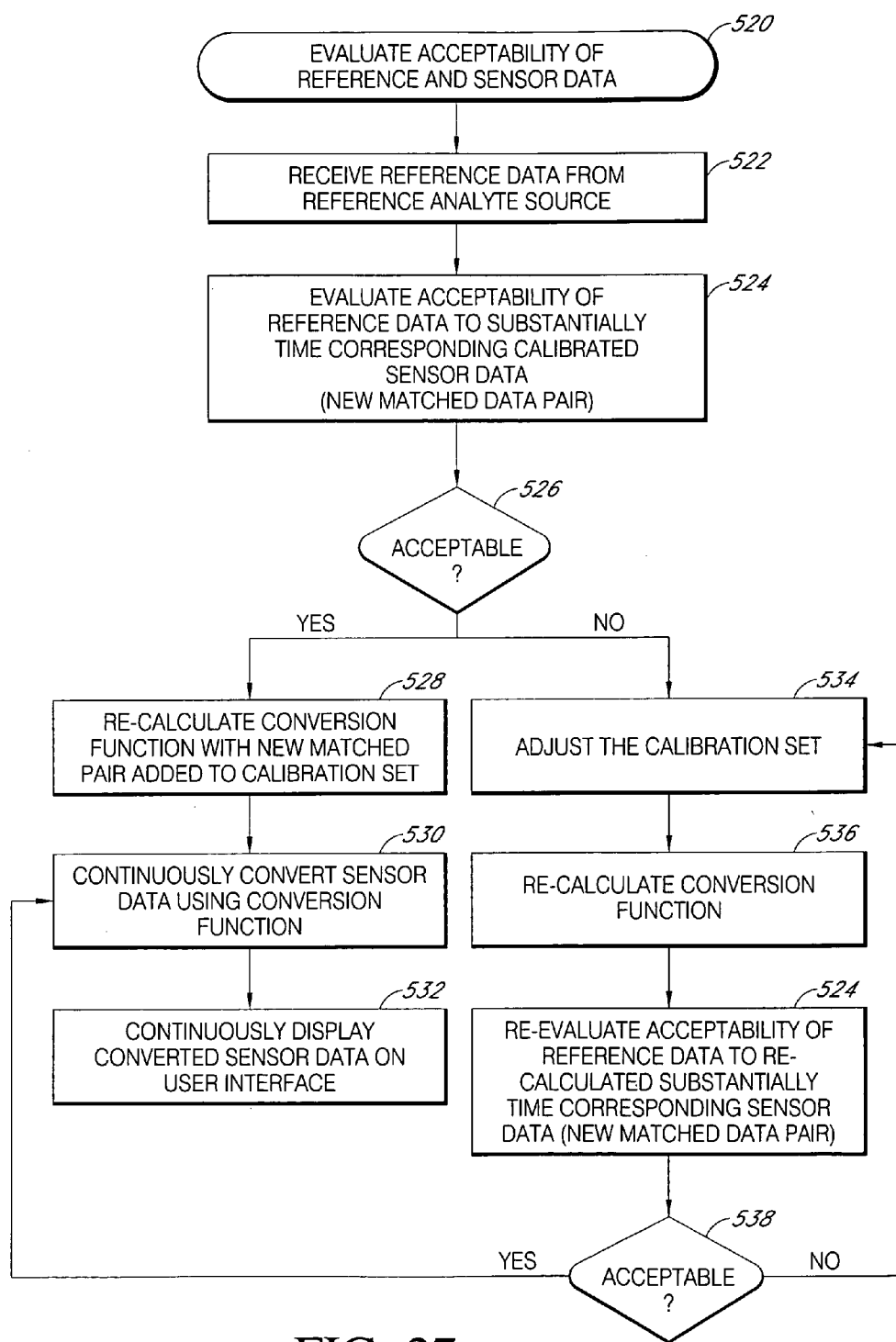

FIG. 27

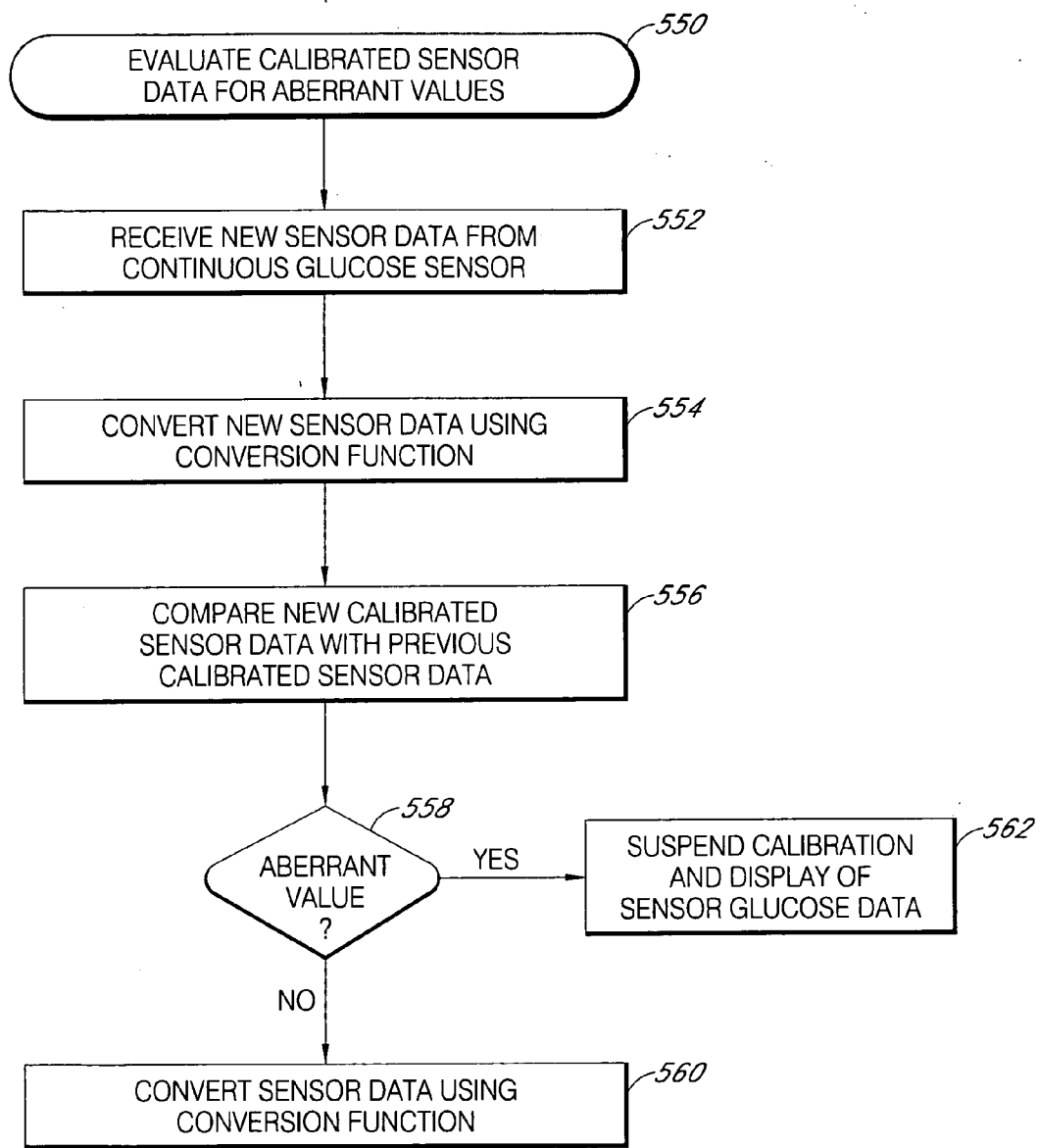

FIG. 28

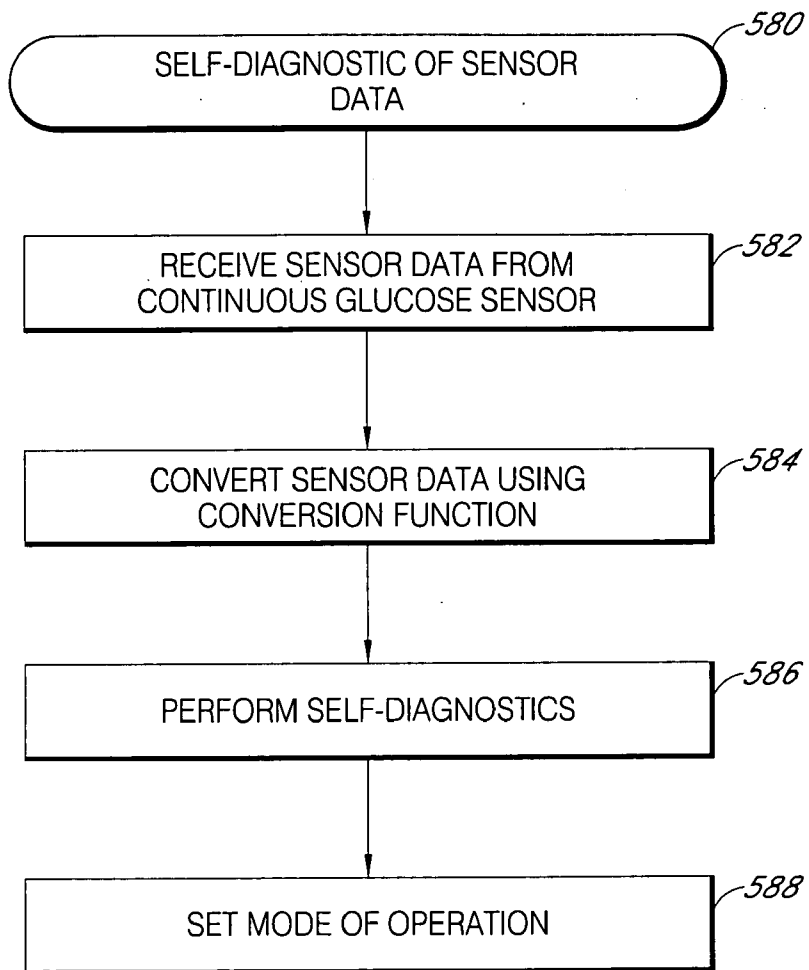

FIG. 29

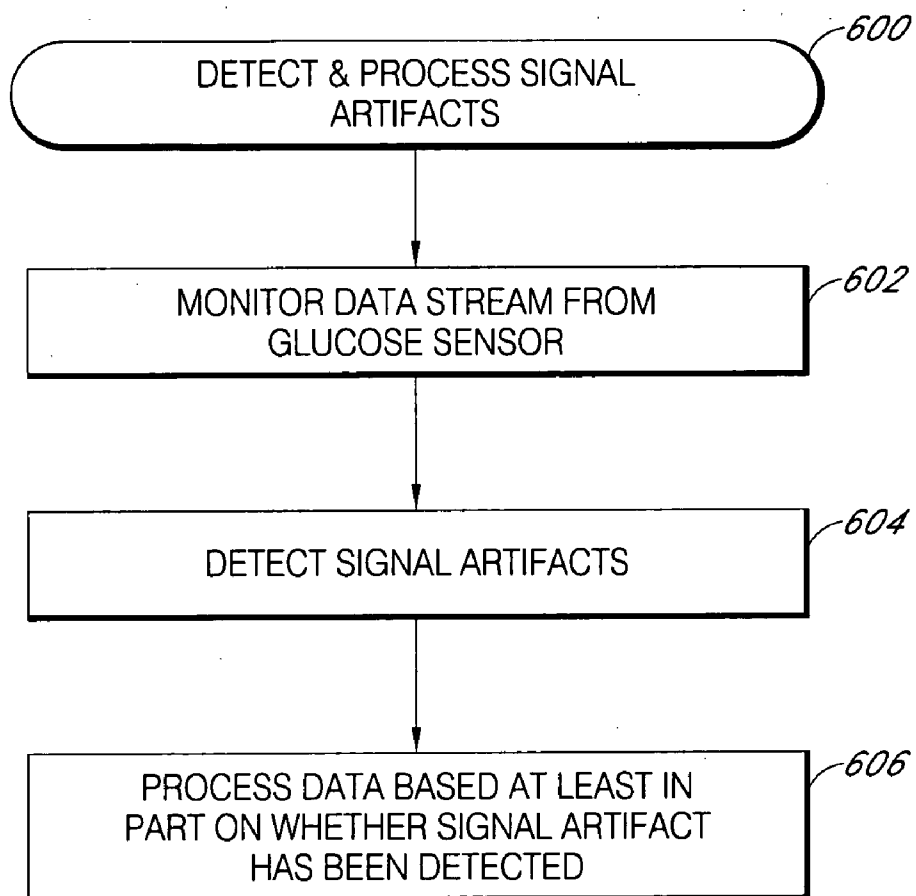

FIG. 30

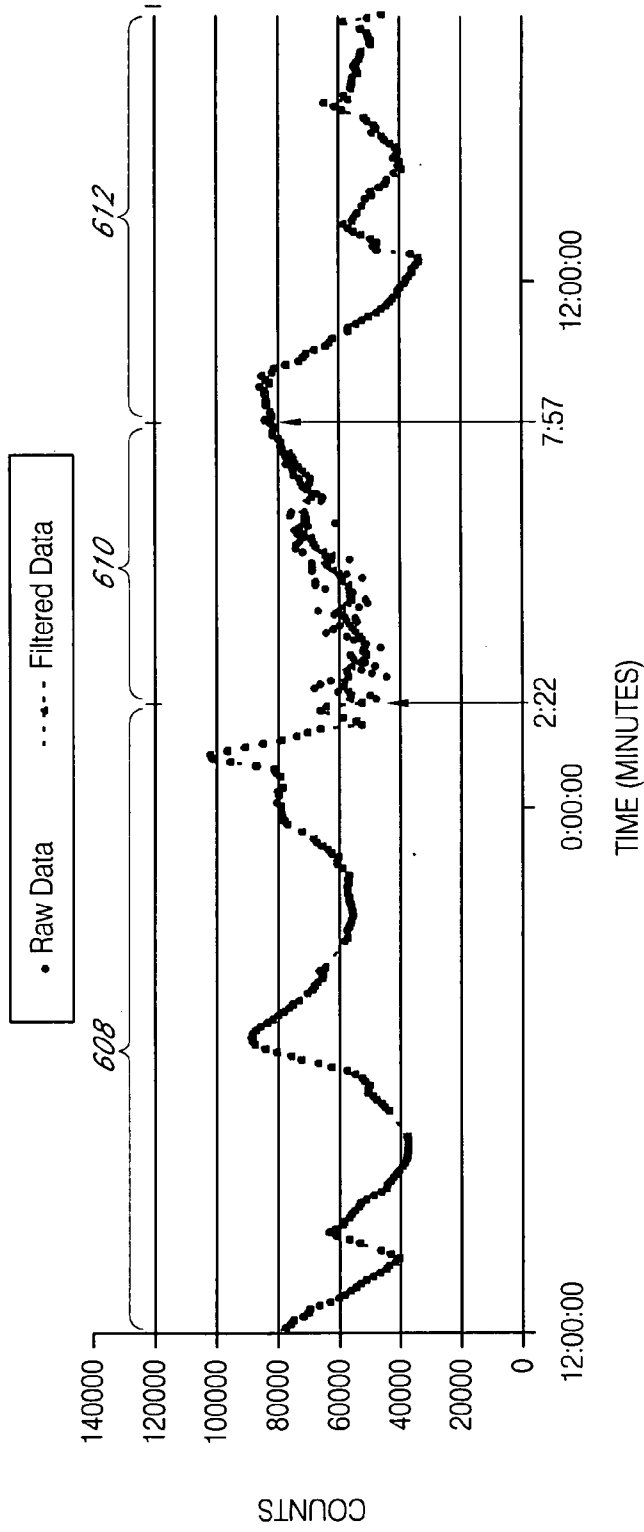

FIG. 31

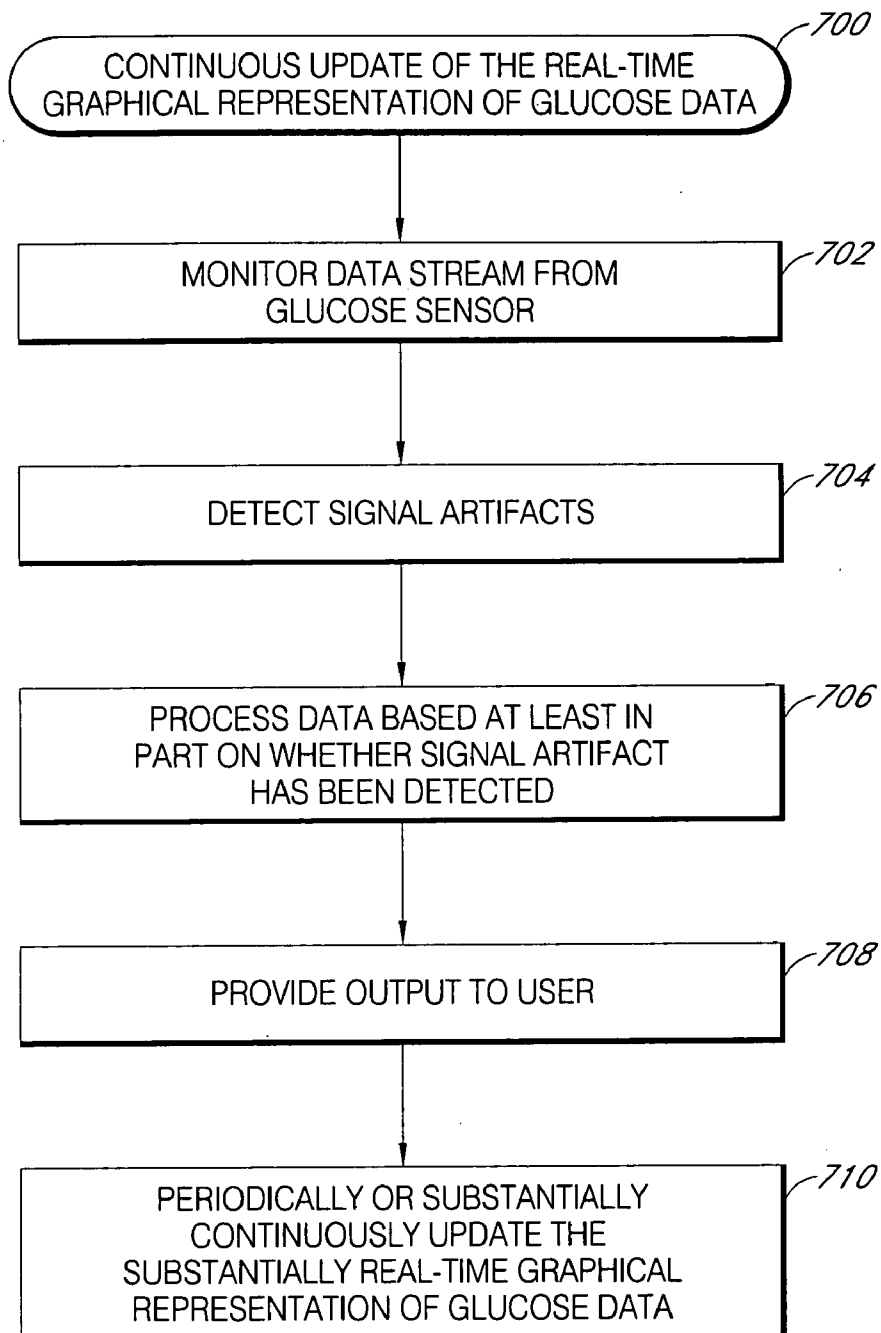

FIG. 32

## SYSTEMS AND METHODS FOR REPLACING SIGNAL ARTIFACTS IN A GLUCOSE SENSOR DATA STREAM

### RELATED APPLICATIONS

[0001] This application is a continuation-in-part of U.S. application Ser. No. 10/648,849, filed Aug. 22, 2003. This application is also a continuation-in-part of U.S. application Ser. No. 11/007,920, filed Dec. 8, 2004, which claims the benefit of U.S. Provisional Application No. 60/528,382 filed Dec. 9, 2003. This application is also a continuation-in-part of U.S. application Ser. No. 11/077,739, filed Mar. 10, 2005, which claims the benefit of U.S. Provisional Application No. 60/587,787 filed Jul. 13, 2004; U.S. Provisional Application No. 60/587,800 filed Jul. 13, 2004; U.S. Provisional Application No. 60/614,683 filed Sep. 30, 2004; and U.S. Provisional Application No. 60/614,764 filed Sep. 30, 2004. Each of the aforementioned applications is incorporated by reference herein in its entirety, and each is hereby expressly made a part of this specification.

### FIELD OF THE INVENTION

[0002] The present invention relates generally to systems and methods for processing data received from a glucose sensor. Particularly, the present invention relates to systems and methods for detecting and processing signal artifacts, including detecting, estimating, predicting, filtering, displaying, and otherwise minimizing the effects of signal artifacts in a glucose sensor data stream.

### BACKGROUND OF THE INVENTION

[0003] Diabetes mellitus is a disorder in which the pancreas cannot create sufficient insulin (Type I or insulin dependent) and/or in which insulin is not effective (Type 2 or non-insulin dependent). In the diabetic state, the victim suffers from high blood sugar, which causes an array of physiological derangements (kidney failure, skin ulcers, or bleeding into the vitreous of the eye) associated with the deterioration of small blood vessels. A hypoglycemic reaction (low blood sugar) is induced by an inadvertent overdose of insulin, or after a normal dose of insulin or glucose-lowering agent accompanied by extraordinary exercise or insufficient food intake.

[0004] Conventionally, a diabetic person carries a self-monitoring blood glucose (SMBG) monitor, which typically comprises uncomfortable finger pricking methods. Due to the lack of comfort and convenience, a diabetic will normally only measure his or her glucose level two to four times per day. Unfortunately, these time intervals are so far spread apart that the diabetic will likely find out too late, sometimes incurring dangerous side effects, of a hyperglycemic or hypoglycemic condition. In fact, it is not only unlikely that a diabetic will take a timely SMBG value, but additionally the diabetic will not know if their blood glucose value is going up (higher) or down (lower) based on conventional methods.

[0005] Consequently, a variety of transdermal and implantable electrochemical sensors are being developed for continuous detecting and/or quantifying blood glucose values. Many implantable glucose sensors suffer from complications within the body and provide only short-term and less-than-accurate sensing of blood glucose. Similarly,

transdermal sensors have run into problems in accurately sensing and reporting back glucose values continuously over extended periods of time. Some efforts have been made to obtain blood glucose data from implantable devices and retrospectively determine blood glucose trends for analysis; however these efforts do not aid the diabetic in determining real-time blood glucose information. Some efforts have also been made to obtain blood glucose data from transdermal devices for prospective data analysis, however similar problems have occurred.

[0006] Data streams from glucose sensors are known to have some amount of noise, caused by unwanted electronic and/or diffusion-related system noise that degrades the quality of the data stream. Some attempts have been made in conventional glucose sensors to smooth the raw output data stream representative of the concentration of blood glucose in the sample, for example by smoothing or filtering of Gaussian, white, random, and/or other relatively low amplitude noise in order to improve the signal to noise ratio, and thus data output.

### SUMMARY OF THE INVENTION

[0007] Systems and methods are provided that accurately detect signal noise that is caused by substantially non-glucose reaction rate-limiting phenomena, such as interfering species, ischemia, pH changes, temperature changes, pressure, and stress, for example, which are referred to herein as signal artifacts or "noise episodes". Detecting signal artifacts and processing the sensor data based on detection of signal artifacts provides accurate estimated glucose measurements to a diabetic patient so that they can proactively care for their condition to safely avoid hyperglycemic and hypoglycemic conditions.

[0008] Accordingly, in a first aspect, a method of analyzing data from an analyte sensor is provided, the method comprising receiving data from the analyte sensor, the data comprising at least one sensor data point; determining whether a signal artifact event has occurred; and processing the received data, wherein the processing is based at least in part upon whether the signal artifact event has occurred.

[0009] In an embodiment of the first aspect, the method further comprises filtering the received data to generate filtered data.

[0010] In an embodiment of the first aspect, determining whether a signal artifact has occurred comprises comparing the received data with the filtered data to obtain at least one residual.

[0011] In an embodiment of the first aspect, a signal artifact event is determined to have occurred if the residual is exceeds a threshold value.

[0012] In an embodiment of the first aspect, the method further comprises determining whether another signal artifact event has occurred, wherein another signal artifact event has occurred if the residual exceeds a second threshold value.

[0013] In an embodiment of the first aspect, a signal artifact event is determined to have occurred if the residual is exceeds a threshold value for a predetermined period of time or for a predetermined amount of data.

[0014] In an embodiment of the first aspect, determining whether a signal artifact has occurred further comprises determining whether a predetermined number of residuals exceed a threshold over a predetermined period of time, or whether a predetermined amount of data exceeds a threshold.

[0015] In an embodiment of the first aspect, determining whether a signal artifact event has occurred further comprises determining a differential between a first residual at a first time point and a second residual at a second time point.

[0016] In an embodiment of the first aspect, determining whether a signal artifact event has occurred further comprises determining whether a predetermined number of differentials exceed a threshold over a predetermined period of time, or whether an amount of data exceeds a threshold.

[0017] In an embodiment of the first aspect, the method further comprises receiving reference data from a reference analyte monitor, the reference data including at least one reference data point.

[0018] In an embodiment of the first aspect, processing the received data further comprises determining a reliability of the received data, wherein processing is conducted if the signal artifact event is determined to have not occurred.

[0019] In an embodiment of the first aspect, the method further comprises matching the reference data to substantially time corresponding received data to form a matching data pair, wherein the reference data is matched if the signal artifact event is determined to have not occurred.

[0020] In an embodiment of the first aspect, the method further comprises including the reference data in a calibration factor for use in calibrating the glucose sensor, wherein the reference data is included if the signal artifact event is determined to have not occurred.

[0021] In an embodiment of the first aspect, the method further comprises prompting a user for a reference glucose value, wherein prompting is conducted if the signal artifact event is determined to have not occurred.

[0022] In an embodiment of the first aspect, processing the received data comprises displaying a graphical representation of the received data.

[0023] In an embodiment of the first aspect, processing the received data comprises filtering the received data, wherein filtering is conducted if the signal artifact event is determined to have occurred.

[0024] In an embodiment of the first aspect, the method further comprises filtering the received data, wherein processing the received data comprises displaying a graphical representation of the filtered data, wherein processing is conducted if the signal artifact event is determined to have occurred.

[0025] In an embodiment of the first aspect, the method further comprises filtering the received data to generate filtered data, wherein determining whether a signal artifact event has occurred further comprises comparing the received data with the filtered data to obtain a residual, and wherein processing the received data comprises utilizing the residual to modify the filtered data.

[0026] In an embodiment of the first aspect, the method further comprises filtering the received data to generate filtered data, wherein determining whether a signal artifact event has occurred further comprises comparing the received data with the filtered data to obtain a residual and deriving a differential of the residual by calculating a first derivative of the residual, and wherein processing the received data comprises utilizing the differential to modify the filtered data.

[0027] In an embodiment of the first aspect, processing the received data comprises compensating for a time lag.

[0028] In an embodiment of the first aspect, processing the received data comprises displaying a graphical representation of the received data.

[0029] In an embodiment of the first aspect, the received data is an unfiltered digital signal.

[0030] In an embodiment of the first aspect, processing the received data comprises disabling display of a graphical representation of the received data, wherein processing is conducted if the signal artifact event is determined to have occurred.

[0031] In an embodiment of the first aspect, processing the received data comprises displaying a range of glucose values, wherein processing is conducted if the signal artifact event is determined to have occurred.

[0032] In an embodiment of the first aspect, processing the received data comprises displaying a graphical indication of glucose trend, wherein processing is conducted if the signal artifact event is determined to have occurred.

[0033] In an embodiment of the first aspect, processing the received data comprises generating at least one estimated glucose value and displaying a graphical representation of the estimated glucose value, wherein processing is conducted if the signal artifact event is determined to have occurred.

[0034] In an embodiment of the first aspect, processing the received data comprises generating a confidence interval for at least one estimated glucose value and displaying a graphical representation of the confidence interval, wherein processing is conducted if the signal artifact event is determined to have occurred.

[0035] In a second aspect, a method for processing data from a glucose sensor is provided, the method comprising receiving data from the glucose sensor, the received data comprising at least one sensor data point; displaying a graphical representation of the data corresponding to a time period; and post-processing the displayed graphical representation of the data corresponding to the time period.

[0036] In an embodiment of the second aspect, post-processing is conducted periodically.

[0037] In an embodiment of the second aspect, post-processing is conducted substantially continuously.

[0038] In an embodiment of the second aspect, the method further comprises determining whether a signal artifact event has occurred and processing the received data prior to the displaying step, wherein the processing is based at least in part upon whether the signal artifact event has occurred.



[0039] In an embodiment of the second aspect, post-processing comprises filtering the data to recalculate data corresponding to the time period and displaying a graphical representation of the recalculated data corresponding to the time period.

[0040] In an embodiment of the second aspect, the step of post-processing comprises recalculating data corresponding to the time period, wherein a time lag induced by real-time filtering is substantially removed from the data corresponding to the time period; and displaying a graphical representation of the recalculated data corresponding to the time period.

[0041] In an embodiment of the second aspect, recalculating the data comprises algorithmically smoothing at least one sensor data point over a moving window, wherein the moving window comprises time points before and after the sensor data point is obtained.

[0042] In an embodiment of the second aspect, the method further comprises displaying a current glucose value representative of the most recently obtained sensor data point.

[0043] In a third aspect, a system configured to process data from an analyte sensor is provided, the system comprising a data receiving module configured to receive sensor data from the analyte sensor, the data comprising at least one sensor data point; a signal artifacts module configured to detect a signal artifact in the sensor data; and a processor module configured to process the sensor data, wherein processing is dependent at least in part upon whether the signal artifact is detected.

[0044] In an embodiment of the third aspect, the signal artifacts module is configured to compare raw sensor data with filtered sensor data to determine a residual.

[0045] In an embodiment of the third aspect, the signal artifacts module is configured to detect a signal artifact if the residual exceeds a threshold value.

[0046] In an embodiment of the third aspect, the signal artifacts module is configured to detect a signal artifact if a predetermined number of residuals exceed a threshold value for a predetermined period of time or for a predetermined amount of data.

[0047] In an embodiment of the third aspect, the signal artifacts module is configured to compare a first residual with a second signal residual to determine a differential.

[0048] In an embodiment of the third aspect, the signal artifacts module is configured to detect a signal artifact if the differential exceeds a threshold value.

[0049] In an embodiment of the third aspect, the signal artifacts module is configured to detect a signal artifact if a predetermined number of differentials exceed a threshold value for a predetermined period of time or for a predetermined amount of data.

[0050] In an embodiment of the third aspect, the system further comprises a reference data module configured to receive reference data from a reference glucose monitor, the reference data comprising at least one reference data point.

[0051] In an embodiment of the third aspect, the signal artifacts module is configured to determine a reliability of the sensor data if the signal artifact is detected.

[0052] In an embodiment of the third aspect, the processor module is configured to form at least one matched data pair by matching reference data to substantially time corresponding sensor data.

[0053] In an embodiment of the third aspect, the processor module is configured to form a matching data pair if a signal artifact is not detected.

[0054] In an embodiment of the third aspect, the processor module is configured to utilize the reference data for calibrating the glucose sensor if a signal artifact is not detected.

[0055] In an embodiment of the third aspect, the processor module is configured to prompt a user for a reference glucose value if a signal artifact is not detected.

[0056] In an embodiment of the third aspect, the data receiving module is configured to receive raw sensor data.

[0057] In an embodiment of the third aspect, the raw sensor data comprises integrated digital data.

[0058] In an embodiment of the third aspect, the processor module is configured to display a graphical representation of the raw sensor data if a signal artifact is not detected.

[0059] In an embodiment of the third aspect, the data receiving module is configured to receive filtered sensor data.

[0060] In an embodiment of the third aspect, the processor module is configured to display a graphical representation of the filtered sensor data if a signal artifact is detected.

[0061] In an embodiment of the third aspect, the processor module is configured to filter the sensor data.

[0062] In an embodiment of the third aspect, the processor module is configured to display a graphical representation of the filtered sensor data if a signal artifact is detected.

[0063] In an embodiment of the third aspect, the processor module is configured to not display the sensor data if a signal artifact is detected.

[0064] In an embodiment of the third aspect, the processor module is configured to display a range of glucose values if a signal artifact is detected.

[0065] In an embodiment of the third aspect, the processor module is configured to display a directional indicator of glucose trend if a signal artifact is detected.

[0066] In an embodiment of the third aspect, the processor module is configured to display at least one estimated glucose value if a signal artifact is detected.

[0067] In an embodiment of the third aspect, the processor module is configured to display a confidence interval for at least one estimated glucose value if a signal artifact is detected.

[0068] In a fourth aspect, a system configured to process data from an analyte sensor is provided, the system comprising a data receiving module configured to receive sensor data from the analyte sensor, the data comprising at least one sensor data point; an output module configured to display a substantially real-time numerical value corresponding to a most recently received sensor data point and a graphical representation of sensor data corresponding to a time period; and a processor module configured to post-process the

graphical representation of the data corresponding to the time period, wherein the output module is configured to display the post-processed data.

[0069] In an embodiment of the fourth aspect, post-processing is conducted periodically.

[0070] In an embodiment of the fourth aspect, post-processing is conducted substantially continuously.

[0071] In an embodiment of the fourth aspect, the processor module is configured to automatically post-process the graphical representation of the data corresponding to the time period.

[0072] In an embodiment of the fourth aspect, the processor module is configured to post-process the graphical representation of the data corresponding to the time period responsive to a request.

[0073] In an embodiment of the fourth aspect, the output module is configured to automatically display the post-processed graphical representation of the data corresponding to the time period.

[0074] In an embodiment of the fourth aspect, the output module is configured to display the post-processed graphical representation of the data corresponding to the time period responsive to a request.

#### BRIEF DESCRIPTION OF THE DRAWINGS

[0075] FIG. 1A is an exploded perspective view of a glucose sensor in one embodiment.

[0076] FIG. 1B is side view of a distal portion of a transcutaneously inserted sensor in one embodiment.

[0077] FIG. 2 is a block diagram that illustrates sensor electronics in one embodiment.

[0078] FIGS. 3A to 3D are schematic views of a receiver in first, second, third, and fourth embodiments, respectively.

[0079] FIG. 4A is a block diagram of receiver electronics in one embodiment.

[0080] FIG. 4B is an illustration of the receiver in one embodiment showing an analyte trend graph, including measured analyte values, estimated analyte values, and a clinical risk zone.

[0081] FIG. 4C is an illustration of the receiver in another embodiment showing a representation of analyte concentration and directional trend using a gradient bar.

[0082] FIG. 4D is an illustration of the receiver in yet another embodiment, including a screen that shows a numerical representation of the most recent measured analyte value.

[0083] FIG. 5 is a flow chart that illustrates the process of calibrating the sensor data in one embodiment.

[0084] FIG. 6 is a graph that illustrates a linear regression used to calibrate the sensor data in one embodiment.

[0085] FIG. 7A is a graph that shows a raw data stream obtained from a glucose sensor over a 4 hour time span in one example.

[0086] FIG. 7B is a graph that shows a raw data stream obtained from a glucose sensor over a 36 hour time span in another example.

[0087] FIG. 8 is a flow chart that illustrates the process of detecting and replacing transient non-glucose related signal artifacts in a data stream in one embodiment.

[0088] FIG. 9 is a graph that illustrates the correlation between the counter electrode voltage and signal artifacts in a data stream from a glucose sensor in one embodiment.

[0089] FIG. 10A is a circuit diagram of a potentiostat that controls a typical three-electrode system in one embodiment.

[0090] FIG. 10B is a diagram known as Cyclic-Voltammetry (CV) curve, which illustrates the relationship between applied potential ( $V_{\text{BIAS}}$ ) and signal strength of the working electrode ( $I_{\text{SENSE}}$ ) and can be used to detect signal artifacts.

[0091] FIG. 10C is a diagram showing a CV curve that illustrates an alternative embodiment of signal artifacts detection, wherein pH and/or temperature can be monitoring using the CV curve.

[0092] FIG. 11 is a graph and spectrogram that illustrate the correlation between high frequency and signal artifacts observed by monitoring the frequency content of a data stream in one embodiment.

[0093] FIG. 12 is a graph that illustrates a data stream obtained from a glucose sensor and a signal smoothed by trimmed linear regression that can be used to replace some of or the entire raw data stream in one embodiment.

[0094] FIG. 13 is a graph that illustrates a data stream obtained from a glucose sensor and a FIR-smoothed data signal that can be used to replace some of or the entire raw data stream in one embodiment.

[0095] FIG. 14 is a graph that illustrates a data stream obtained from a glucose sensor and an IIR-smoothed data signal that can be used to replace some of or the entire raw data stream in one embodiment.

[0096] FIG. 15 is a flowchart that illustrates the process of selectively applying signal estimation based on the severity of signal artifacts on a data stream.

[0097] FIG. 16 is a graph that illustrates selectively applying a signal estimation algorithm responsive to positive detection of signal artifacts on the raw data stream.

[0098] FIG. 17 is a graph that illustrates selectively applying a plurality of signal estimation algorithm factors responsive to a severity of signal artifacts on the raw data stream.

[0099] FIG. 18 is a flow chart that illustrates dynamic and intelligent estimation algorithm selection process in an alternative embodiment.

[0100] FIG. 19 is a graph that illustrates dynamic and intelligent estimation algorithm selection applied to a data stream in one embodiment.

[0101] FIG. 20 is a flow chart that illustrates the process of dynamic and intelligent estimation and evaluation of analyte values in one embodiment.

[0102] FIG. 21 is a graph that illustrates an evaluation of the selected estimative algorithm in one embodiment.

[0103] FIG. 22 is a flow chart that illustrates the process of analyzing a variation of estimated future analyte value possibilities in one embodiment.

[0104] FIG. 23 is a graph that illustrates variation analysis of estimated glucose values in one embodiment.

[0105] FIG. 24 is a graph that illustrates variation of estimated analyte values in another embodiment.

[0106] FIG. 25 is a flow chart that illustrates the process of estimating, measuring, and comparing analyte values in one embodiment.

[0107] FIG. 26 is a graph that illustrates comparison of estimated analyte values in one embodiment.

[0108] FIG. 27 provides a flow chart that illustrates the evaluation of reference and/or sensor data for statistical, clinical, and/or physiological acceptability in one embodiment.

[0109] FIG. 28 is a flow chart that illustrates the evaluation of calibrated sensor data for aberrant values in one embodiment.

[0110] FIG. 29 provides a flow chart that illustrates a self-diagnostic of sensor data in one embodiment.

[0111] FIG. 30 is a flow chart that illustrates the process of detecting and processing signal artifacts in certain embodiments.

[0112] FIG. 31 is a graph that illustrates a raw data stream from a glucose sensor for approximately 24 hours with a filtered version of the same data stream superimposed on the same graph.

[0113] FIG. 32 is a flowchart that illustrates a method for processing data from a glucose sensor in certain embodiments.

#### DETAILED DESCRIPTION OF THE PREFERRED EMBODIMENTS

[0114] The following description and examples illustrate some exemplary embodiments of the disclosed invention in detail. Those of skill in the art will recognize that there are numerous variations and modifications of this invention that are encompassed by its scope. Accordingly, the description of a certain exemplary embodiment should not be deemed to limit the scope of the present invention.

#### Definitions

[0115] In order to facilitate an understanding of the preferred embodiments, a number of terms are defined below.

[0116] The term "analyte" as used herein is a broad term and is to be given its ordinary and customary meaning to a person of ordinary skill in the art (and is not to be limited to a special or customized meaning), and furthermore refers without limitation to a substance or chemical constituent in a biological fluid (for example, blood, interstitial fluid, cerebral spinal fluid, lymph fluid or urine) that can be analyzed. Analytes can include naturally occurring substances, artificial substances, metabolites, and/or reaction products. In some embodiments, the analyte for measurement by the sensor heads, devices, and methods is analyte. However, other analytes are contemplated as well, including but not limited to acarboxyprothrombin; acylcamitine;

adenine phosphoribosyl transferase; adenosine deaminase; albumin; alpha-fetoprotein; amino acid profiles (arginine (Krebs cycle), histidine/urocanic acid, homocysteine, phenylalanine/tyrosine, tryptophan); adrenostenedione; anti-pyrene; arabinitol enantiomers; arginase; benzoylcegonine (cocaine); biotinidase; biopterin; c-reactive protein; carnitine; camosinase; CD4; ceruloplasmin; chenodeoxycholic acid; chloroquine; cholesterol; cholinesterase; conjugated 1- $\beta$  hydroxy-cholic acid; cortisol; creatine kinase; creatine kinase MM isoenzyme; cyclosporin A; d-penicillamine; de-ethylchloroquine; dehydroepiandrosterone sulfate; DNA (acetylator polymorphism, alcohol dehydrogenase, alpha 1-antitrypsin, cystic fibrosis, Duchenne/Becker muscular dystrophy, analyte-6-phosphate dehydrogenase, hemoglobin A, hemoglobin S, hemoglobin C, hemoglobin D, hemoglobin E, hemoglobin F, D-Punjab, beta-thalassemia, hepatitis B virus, HCMV, HIV-1, HTLV-1, Leber hereditary optic neuropathy, MCAD, RNA, PKU, *Plasmodium vivax*, sexual differentiation, 21-deoxycortisol); desbutylhalofantrine; dihydropteridine reductase; diphtheria/tetanus antitoxin; erythrocyte arginase; erythrocyte protoporphyrin; esterase D; fatty acids/acylglycines; free  $\beta$ -human chorionic gonadotropin; free erythrocyte porphyrin; free thyroxine (FT4); free tri-iodothyronine (FT3); fumarylacetoacetase; galactose/gal-1-phosphate; galactose-1-phosphate uridylyltransferase; gentamicin; analyte-6-phosphate dehydrogenase; glutathione; glutathione peroxidase; glycocholic acid; glycosylated hemoglobin; halofantrine; hemoglobin variants; hexosaminidase A; human erythrocyte carbonic anhydrase I; 17-alpha-hydroxyprogesterone; hypoxanthine phosphoribosyl transferase; immunoreactive trypsin; lactate; lead; lipoproteins ((a), B/A-1,  $\beta$ ); lysozyme; mefloquine; netilmicin; phenobarbitone; phenyloloin; phytanic/pristanic acid; progesterone; prolactin; prolidase; purine nucleoside phosphorylase; quinine; reverse tri-iodothyronine (rT3); selenium; serum pancreatic lipase; sissomicin; somatomedin C; specific antibodies (adenovirus, anti-nuclear antibody, anti-zeta antibody, arbovirus, Aujeszky's disease virus, dengue virus, *Dracunculus medinensis*, *Echinococcus granulosus*, *Entamoeba histolytica*, enterovirus, *Giardia duodenalis*, *Helicobacter pylori*, hepatitis B virus, herpes virus, HIV-1, IgE (atopic disease), influenza virus, *Leishmania donovani*, *Leptospira*, measles/mumps/rubella, *Mycobacterium leprae*, *Mycoplasma pneumoniae*, Myoglobin, *Onchocerca volvulus*, parainfluenza virus, *Plasmodium falciparum*, poliovirus, *Pseudomonas aeruginosa*, respiratory syncytial virus, *Rickettsia* (scrub typhus), *Schistosoma mansoni*, *Toxoplasma gondii*, *Treponema pallidum*, *Trypanosoma cruzi/rangeli*, vesicular stomatitis virus, *Wuchereria bancrofti*, yellow fever virus); specific antigens (hepatitis B virus, HIV-1); succinylacetone; sulfadoxine; theophylline; thyrotropin (TSH); thyroxine (T4); thyroxine-binding globulin; trace elements; transferrin; UDP-galactose-4-epimerase; urea; uroporphyrinogen I synthase; vitamin A; white blood cells; and

[0117] zinc protoporphyrin. Salts, sugar, protein, fat, vitamins, and hormones naturally occurring in blood or interstitial fluids can also constitute analytes in certain embodiments. The analyte can be naturally present in the biological fluid, for example, a metabolic product, a hormone, an antigen, an antibody, and the like. Alternatively, the analyte can be introduced into the body, for example, a contrast agent for imaging, a radioisotope, a chemical agent, a fluorocarbon-based synthetic blood, or a drug or pharmaceutical composition, including but not limited to insulin;

ethanol; *cannabis* (marijuana, tetrahydrocannabinol, hashish); inhalants (nitrous oxide, amyl nitrite, butyl nitrite, chlorohydrocarbons, hydrocarbons); cocaine (crack cocaine); stimulants (amphetamines, methamphetamines, Ritalin, Cylert, Preludin, Didrex, PreState, Voranil, Sandrex, Plegine); depressants (barbituates, methaqualone, tranquilizers such as Valium, Librium, Miltown, Serax, Equanil, Tranxene); hallucinogens (phencyclidine, lysergic acid, mescaline, peyote, psilocybin); narcotics (heroin, codeine, morphine, opium, meperidine, Percocet, Percodan, Tussonex, Fentanyl, Darvon, Talwin, Lomotil); designer drugs (analogs of fentanyl, meperidine, amphetamines, methamphetamines, and phencyclidine, for example, Ecstasy); anabolic steroids; and nicotine. The metabolic products of drugs and pharmaceutical compositions are also contemplated analytes. Analytes such as neurochemicals and other chemicals generated within the body can also be analyzed, such as, for example, ascorbic acid, uric acid, dopamine, noradrenaline, 3-methoxytyramine (MT), 3,4-Dihydroxyphenylacetic acid (DOPAC), Homovanillic acid (HVA), 5-Hydroxytryptamine (5HT), and 5-Hydroxyindoleacetic acid (FHIAA).

[0118] The term “EEPROM” as used herein is a broad term and is to be given its ordinary and customary meaning to a person of ordinary skill in the art (and is not to be limited to a special or customized meaning), and furthermore refers without limitation to electrically erasable programmable read-only memory, which is user-modifiable read-only memory (ROM) that can be erased and reprogrammed (e.g., written to) repeatedly through the application of higher than normal electrical voltage.

[0119] The term “SRAM” as used herein is a broad term and is to be given its ordinary and customary meaning to a person of ordinary skill in the art (and is not to be limited to a special or customized meaning), and furthermore refers without limitation to static random access memory (RAM) that retains data bits in its memory as long as power is being supplied.

[0120] The term “ROM” as used herein is a broad term and is to be given its ordinary and customary meaning to a person of ordinary skill in the art (and is not to be limited to a special or customized meaning), and furthermore refers without limitation to read-only memory, which is a type of data storage device manufactured with fixed contents. ROM is broad enough to include EEPROM, for example, which is electrically erasable programmable read-only memory (ROM).

[0121] The term “RAM” as used herein is a broad term and is to be given its ordinary and customary meaning to a person of ordinary skill in the art (and is not to be limited to a special or customized meaning), and furthermore refers without limitation to a data storage device for which the order of access to different locations does not affect the speed of access. RAM is broad enough to include SRAM, for example, which is static random access memory that retains data bits in its memory as long as power is being supplied.

[0122] The term “A/D Converter” as used herein is a broad term and is to be given its ordinary and customary meaning to a person of ordinary skill in the art (and is not to be limited to a special or customized meaning), and

furthermore refers without limitation to hardware and/or software that converts analog electrical signals into corresponding digital signals.

[0123] The terms “microprocessor” and “processor” as used herein are broad terms and are to be given their ordinary and customary meaning to a person of ordinary skill in the art (and are not to be limited to a special or customized meaning), and furthermore refer without limitation to a computer system, state machine, and the like that performs arithmetic and logic operations using logic circuitry that responds to and processes the basic instructions that drive a computer.

[0124] The term “RF transceiver” as used herein is a broad term and is to be given its ordinary and customary meaning to a person of ordinary skill in the art (and is not to be limited to a special or customized meaning), and furthermore refers without limitation to a radio frequency transmitter and/or receiver for transmitting and/or receiving signals.

[0125] The term “jitter” as used herein is a broad term and is to be given its ordinary and customary meaning to a person of ordinary skill in the art (and is not to be limited to a special or customized meaning), and furthermore refers without limitation to noise above and below the mean caused by ubiquitous noise caused by a circuit and/or environmental effects; jitter can be seen in amplitude, phase timing, or the width of the signal pulse.

[0126] The terms “raw data stream” and “data stream” as used herein are broad terms and are to be given their ordinary and customary meaning to a person of ordinary skill in the art (and are not to be limited to a special or customized meaning), and furthermore refer without limitation to an analog or digital signal directly related to the measured glucose from the glucose sensor. In one example, the raw data stream is digital data in “counts” converted by an A/D converter from an analog signal (e.g., voltage or amps) and includes one or more data points representative of a glucose concentration. The terms broadly encompass a plurality of time spaced data points from a substantially continuous glucose sensor, which comprises individual measurements taken at time intervals ranging from fractions of a second up to, e.g., 1, 2, or 5 minutes or longer. In another example, the raw data stream includes an integrated digital value, wherein the data includes one or more data points representative of the glucose sensor signal averaged over a time period.

[0127] The term “calibration” as used herein is a broad term and is to be given its ordinary and customary meaning to a person of ordinary skill in the art (and is not to be limited to a special or customized meaning), and furthermore refers without limitation to the process of determining the relationship between the sensor data and the corresponding reference data, which can be used to convert sensor data into meaningful values substantially equivalent to the reference data. In some embodiments, namely, in continuous analyte sensors, calibration can be updated or recalibrated over time as changes in the relationship between the sensor data and reference data occur, for example, due to changes in sensitivity, baseline, transport, metabolism, and the like.

[0128] The terms “calibrated data” and “calibrated data stream” as used herein are broad terms and are to be given their ordinary and customary meaning to a person of ordi-

nary skill in the art (and are not to be limited to a special or customized meaning), and furthermore refer without limitation to data that has been transformed from its raw state to another state using a function, for example a conversion function, to provide a meaningful value to a user.

[0129] The terms “smoothed data” and “filtered data” as used herein are broad terms and are to be given their ordinary and customary meaning to a person of ordinary skill in the art (and are not to be limited to a special or customized meaning), and furthermore refer without limitation to data that has been modified to make it smoother and more continuous and/or to remove or diminish outlying points, for example, by performing a moving average of the raw data stream. Examples of data filters include FIR (finite impulse response), IIR (infinite impulse response), moving average filters, and the like.

[0130] The terms “smoothing” and “filtering” as used herein are broad terms and are to be given their ordinary and customary meaning to a person of ordinary skill in the art (and are not to be limited to a special or customized meaning), and furthermore refer without limitation to modification of a set of data to make it smoother and more continuous or to remove or diminish outlying points, for example, by performing a moving average of the raw data stream.

[0131] The term “algorithm” as used herein is a broad term and is to be given its ordinary and customary meaning to a person of ordinary skill in the art (and is not to be limited to a special or customized meaning), and furthermore refers without limitation to a computational process (for example, programs) involved in transforming information from one state to another, for example, by using computer processing.

[0132] The term “matched data pairs” as used herein is a broad term and is to be given its ordinary and customary meaning to a person of ordinary skill in the art (and is not to be limited to a special or customized meaning), and furthermore refers without limitation to reference data (for example, one or more reference analyte data points) matched with substantially time corresponding sensor data (for example, one or more sensor data points).

[0133] The term “counts” as used herein is a broad term and is to be given its ordinary and customary meaning to a person of ordinary skill in the art (and is not to be limited to a special or customized meaning), and furthermore refers without limitation to a unit of measurement of a digital signal. In one example, a raw data stream measured in counts is directly related to a voltage (e.g., converted by an A/D converter), which is directly related to current from the working electrode. In another example, counter electrode voltage measured in counts is directly related to a voltage.

[0134] The term “sensor” as used herein is a broad term and is to be given its ordinary and customary meaning to a person of ordinary skill in the art (and is not to be limited to a special or customized meaning), and furthermore refers without limitation to the component or region of a device by which an analyte can be quantified.

[0135] The term “needle” as used herein is a broad term and is to be given its ordinary and customary meaning to a person of ordinary skill in the art (and is not to be limited to a special or customized meaning), and furthermore refers

without limitation to a slender hollow instrument for introducing material into or removing material from the body.

[0136] The terms “glucose sensor” and “member for determining the amount of glucose in a biological sample,” as used herein, are broad terms and are used in an ordinary sense, including, without limitation, any mechanism (e.g., enzymatic or non-enzymatic) by which glucose can be quantified. For example, some embodiments utilize a membrane that contains glucose oxidase that catalyzes the conversion of oxygen and glucose to hydrogen peroxide and gluconate, as illustrated by the following chemical reaction:

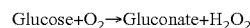

[0137] Because for each glucose molecule metabolized, there is a proportional change in the co-reactant  $\text{O}_2$  and the product  $\text{H}_2\text{O}_2$ , one can use an electrode to monitor the current change in either the co-reactant or the product to determine glucose concentration.

[0138] The terms “operably connected” and “operably linked” as used herein are broad terms and are to be given their ordinary and customary meaning to a person of ordinary skill in the art (and are not to be limited to a special or customized meaning), and furthermore refer without limitation to one or more components being linked to another component(s) in a manner that allows transmission of signals between the components. For example, one or more electrodes can be used to detect the amount of glucose in a sample and convert that information into a signal, e.g., an electrical or electromagnetic signal; the signal can then be transmitted to an electronic circuit. In this case, the electrode is “operably linked” to the electronic circuitry. These terms are broad enough to include wireless connectivity.

[0139] The term “electronic circuitry” as used herein is a broad term and is to be given its ordinary and customary meaning to a person of ordinary skill in the art (and is not to be limited to a special or customized meaning), and furthermore refers without limitation to the components of a device configured to process biological information obtained from a host. In the case of a glucose-measuring device, the biological information is obtained by a sensor regarding a particular glucose in a biological fluid, thereby providing data regarding the amount of that glucose in the fluid. U.S. Pat. Nos. 4,757,022, 5,497,772 and 4,787,398, which are hereby incorporated by reference, describe suitable electronic circuits that can be utilized with devices including the biointerface membrane of a preferred embodiment.

[0140] The term “substantially” as used herein is a broad term and is to be given its ordinary and customary meaning to a person of ordinary skill in the art (and is not to be limited to a special or customized meaning), and furthermore refers without limitation to being largely but not necessarily wholly that which is specified.

[0141] The term “proximal” as used herein is a broad term and is to be given its ordinary and customary meaning to a person of ordinary skill in the art (and is not to be limited to a special or customized meaning), and furthermore refers without limitation to near to a point of reference such as an origin, a point of attachment, or the midline of the body. For example, in some embodiments of a glucose sensor, wherein the glucose sensor is the point of reference, an oxygen sensor located proximal to the glucose sensor will be in

contact with or nearby the glucose sensor such that their respective local environments are shared (e.g., levels of glucose, oxygen, pH, temperature, etc. are similar).

[0142] The term “distal” as used herein is a broad term and is to be given its ordinary and customary meaning to a person of ordinary skill in the art (and is not to be limited to a special or customized meaning), and furthermore refers without limitation to spaced relatively far from a point of reference, such as an origin or a point of attachment, or midline of the body. For example, in some embodiments of a glucose sensor, wherein the glucose sensor is the point of reference, an oxygen sensor located distal to the glucose sensor will be sufficiently far from the glucose sensor such that their respective local environments are not shared (e.g., levels of glucose, oxygen, pH, temperature, etc. may not be similar).

[0143] The term “domain” as used herein is a broad term and is to be given its ordinary and customary meaning to a person of ordinary skill in the art (and is not to be limited to a special or customized meaning), and furthermore refers without limitation to a region of the membrane system that can be a layer, a uniform or non-uniform gradient (for example, an anisotropic region of a membrane), or a portion of a membrane.

[0144] The terms “in vivo portion” and “distal portion” as used herein are broad terms and are to be given their ordinary and customary meaning to a person of ordinary skill in the art (and are not to be limited to a special or customized meaning), and furthermore refer without limitation to the portion of the device (for example, a sensor) adapted for insertion into and/or existence within a living body of a host.

[0145] The terms “ex vivo portion” and “proximal portion” as used herein are broad terms and are to be given their ordinary and customary meaning to a person of ordinary skill in the art (and are not to be limited to a special or customized meaning), and furthermore refer without limitation to the portion of the device (for example, a sensor) adapted to remain and/or exist outside of a living body of a host.

[0146] The term “electrochemical cell” as used herein is a broad term and is to be given its ordinary and customary meaning to a person of ordinary skill in the art (and is not to be limited to a special or customized meaning), and furthermore refers without limitation to a device in which chemical energy is converted to electrical energy. Such a cell typically consists of two or more electrodes held apart from each other and in contact with an electrolyte solution. Connection of the electrodes to a source of direct electric current renders one of them negatively charged and the other positively charged. Positive ions in the electrolyte migrate to the negative electrode (cathode) and there combine with one or more electrons, losing part or all of their charge and becoming new ions having lower charge or neutral atoms or molecules; at the same time, negative ions migrate to the positive electrode (anode) and transfer one or more electrons to it, also becoming new ions or neutral particles. The overall effect of the two processes is the transfer of electrons from the negative ions to the positive ions, a chemical reaction.

[0147] The term “potentiostat” as used herein is a broad term and is to be given its ordinary and customary meaning

to a person of ordinary skill in the art (and is not to be limited to a special or customized meaning), and furthermore refers without limitation to an electrical system that controls the potential between the working and reference electrodes of a three-electrode cell at a preset value. It forces whatever current is necessary to flow between the working and counter electrodes to keep the desired potential, as long as the needed cell voltage and current do not exceed the compliance limits of the potentiostat.

[0148] The term “electrical potential” as used herein is a broad term and is to be given its ordinary and customary meaning to a person of ordinary skill in the art (and is not to be limited to a special or customized meaning), and furthermore refers without limitation to the electrical potential difference between two points in a circuit which is the cause of the flow of a current.

[0149] The term “host” as used herein is a broad term and is to be given its ordinary and customary meaning to a person of ordinary skill in the art (and is not to be limited to a special or customized meaning), and furthermore refers without limitation to mammals, particularly humans.

[0150] The term “continuous analyte (or glucose) sensor” as used herein is a broad term and is to be given its ordinary and customary meaning to a person of ordinary skill in the art (and is not to be limited to a special or customized meaning), and furthermore refers without limitation to a device that continuously or continually measures a concentration of an analyte, for example, at time intervals ranging from fractions of a second up to, for example, 1, 2, or 5 minutes, or longer. In one exemplary embodiment, the continuous analyte sensor is a glucose sensor such as described in U.S. Pat. No. 6,001,067, which is incorporated herein by reference in its entirety.

[0151] The term “continuous analyte (or glucose) sensing” as used herein is a broad term and is to be given its ordinary and customary meaning to a person of ordinary skill in the art (and is not to be limited to a special or customized meaning), and furthermore refers without limitation to the period in which monitoring of an analyte is continuously or continually performed, for example, at time intervals ranging from fractions of a second up to, for example, 1, 2, or 5 minutes, or longer.

[0152] The terms “reference analyte monitor,” “reference analyte meter,” and “reference analyte sensor” as used herein are broad terms and are to be given their ordinary and customary meaning to a person of ordinary skill in the art (and are not to be limited to a special or customized meaning), and furthermore refer without limitation to a device that measures a concentration of an analyte and can be used as a reference for the continuous analyte sensor, for example a self-monitoring blood glucose meter (SMBG) can be used as a reference for a continuous glucose sensor for comparison, calibration, and the like.

[0153] The terms “sensor head” and “sensing region” as used herein are broad terms and are to be given their ordinary and customary meaning to a person of ordinary skill in the art (and are not to be limited to a special or customized meaning), and furthermore refer without limitation to the region of a monitoring device responsible for the detection of a particular analyte. The sensing region generally comprises a non-conductive body, a working elec-

trode (anode), a reference electrode (optional), and/or a counter electrode (cathode) passing through and secured within the body forming electrochemically reactive surfaces on the body and an electronic connective means at another location on the body, and a multi-domain membrane affixed to the body and covering the electrochemically reactive surface.

**[0154]** The term “electrochemically reactive surface” as used herein is a broad term and is to be given its ordinary and customary meaning to a person of ordinary skill in the art (and is not to be limited to a special or customized meaning), and furthermore refers without limitation to the surface of an electrode where an electrochemical reaction takes place. In the case of the working electrode, the hydrogen peroxide produced by the enzyme catalyzed reaction of the glucose being detected reacts creating a measurable electronic current (e.g., detection of glucose utilizing glucose oxidase produces  $H_2O_2$  as a by product,  $H_2O_2$  reacts with the surface of the working electrode producing two protons ( $2H^+$ ), two electrons ( $2e^-$ ) and one molecule of oxygen ( $O_2$ ) which produces the electronic current being detected). In the case of the counter electrode, a reducible species, e.g.,  $O_2$  is reduced at the electrode surface in order to balance the current being generated by the working electrode.

**[0155]** The term “electronic connection” as used herein is a broad term and is to be given its ordinary and customary meaning to a person of ordinary skill in the art (and is not to be limited to a special or customized meaning), and furthermore refers without limitation to any electronic connection known to those in the art that can be utilized to interface the sensor head electrodes with the electronic circuitry of a device such as mechanical (e.g., pin and socket) or soldered.

**[0156]** The term “sensing membrane” as used herein is a broad term and is to be given its ordinary and customary meaning to a person of ordinary skill in the art (and is not to be limited to a special or customized meaning), and furthermore refers without limitation to a permeable or semi-permeable membrane that can be comprised of two or more domains and is typically constructed of materials of a few microns thickness or more, which are permeable to oxygen and may or may not be permeable to glucose. In one example, the sensing membrane comprises an immobilized glucose oxidase enzyme, which enables an electrochemical reaction to occur to measure a concentration of glucose.

**[0157]** The term “biointerface membrane” as used herein is a broad term and is to be given its ordinary and customary meaning to a person of ordinary skill in the art (and is not to be limited to a special or customized meaning), and furthermore refers without limitation to a permeable membrane that can be comprised of two or more domains and is typically constructed of materials of a few microns thickness or more, which can be placed over the sensor body to keep host cells (e.g., macrophages) from gaining proximity to, and thereby damaging, the sensing membrane or forming a barrier cell layer and interfering with the transport of glucose across the tissue-device interface.

**[0158]** The term “Clarke Error Grid” as used herein is a broad term and is to be given its ordinary and customary meaning to a person of ordinary skill in the art (and is not to be limited to a special or customized meaning), and furthermore refers without limitation to an error grid analy-

sis, which evaluates the clinical significance of the difference between a reference glucose value and a sensor generated glucose value, taking into account 1) the value of the reference glucose measurement, 2) the value of the sensor glucose measurement, 3) the relative difference between the two values, and 4) the clinical significance of this difference. See Clarke et al., “Evaluating Clinical Accuracy of Systems for Self-Monitoring of Blood Glucose,” *Diabetes Care*, Volume 10, Number 5, September-October 1987, which is incorporated by reference herein in its entirety.

**[0159]** The term “physiologically feasible” as used herein is a broad term and is to be given its ordinary and customary meaning to a person of ordinary skill in the art (and is not to be limited to a special or customized meaning), and furthermore refers without limitation to the physiological parameters obtained from continuous studies of glucose data in humans and/or animals. For example, a maximal sustained rate of change of glucose in humans of about 4 to 5 mg/dL/min and a maximum acceleration of the rate of change of about 0.1 to 0.2 mg/dL/min/min are deemed physiologically feasible limits. Values outside of these limits would be considered non-physiological and likely a result of signal error, for example. As another example, the rate of change of glucose is lowest at the maxima and minima of the daily glucose range, which are the areas of greatest risk in patient treatment, thus a physiologically feasible rate of change can be set at the maxima and minima based on continuous studies of glucose data. As a further example, it has been observed that the best solution for the shape of the curve at any point along glucose signal data stream over a certain time period (e.g., about 20 to 30 minutes) is a straight line, which can be used to set physiological limits.

**[0160]** The term “ischemia” as used herein is a broad term and is to be given its ordinary and customary meaning to a person of ordinary skill in the art (and is not to be limited to a special or customized meaning), and furthermore refers without limitation to local and temporary deficiency of blood supply due to obstruction of circulation to a part (e.g., sensor). Ischemia can be caused by mechanical obstruction (e.g., arterial narrowing or disruption) of the blood supply, for example.

**[0161]** The term “system noise” as used herein is a broad term and is to be given its ordinary and customary meaning to a person of ordinary skill in the art (and is not to be limited to a special or customized meaning), and furthermore refers without limitation to unwanted electronic or diffusion-related noise which can include Gaussian, motion-related, flicker, kinetic, or other white noise, for example.

**[0162]** The terms “noise,” “noise event(s),” “noise episode(s),” “signal artifact(s),” “signal artifact event(s),” and “signal artifact episode(s)” as used herein are broad terms and are to be given their ordinary and customary meaning to a person of ordinary skill in the art (and are not to be limited to a special or customized meaning), and furthermore refer without limitation to signal noise that is caused by substantially non-glucose related, such as interfering species, macro- or micro-motion, ischemia, pH changes, temperature changes, pressure, stress, or even unknown sources of mechanical, electrical and/or biochemical noise for example. In some embodiments, signal artifacts are transient and characterized by a higher amplitude than system noise, and described as “transient non-glucose related signal arti-

fact(s) that have a higher amplitude than system noise.” In some embodiments, noise is caused by rate-limiting (or rate-increasing) phenomena. In some circumstances, the source of the noise is unknown.

[0163] The terms “low noise” as used herein is a broad term and is to be given its ordinary and customary meaning to a person of ordinary skill in the art (and is not to be limited to a special or customized meaning), and furthermore refers without limitation to noise that substantially decreases signal amplitude.

[0164] The terms “high noise” and “high spikes” as used herein are broad terms and are to be given their ordinary and customary meaning to a person of ordinary skill in the art (and are not to be limited to a special or customized meaning), and furthermore refer without limitation to noise that substantially increases signal amplitude.

[0165] The term “frequency content” as used herein is a broad term and is to be given its ordinary and customary meaning to a person of ordinary skill in the art (and is not to be limited to a special or customized meaning), and furthermore refers without limitation to the spectral density, including the frequencies contained within a signal and their power.

[0166] The term “spectral density” as used herein is a broad term and is to be given its ordinary and customary meaning to a person of ordinary skill in the art (and is not to be limited to a special or customized meaning), and furthermore refers without limitation to power spectral density of a given bandwidth of electromagnetic radiation is the total power in this bandwidth divided by the specified bandwidth. Spectral density is usually expressed in Watts per Hertz (W/Hz).

[0167] The term “orthogonal transform” as used herein is a broad term and is to be given its binary and customary meaning to a person of ordinary skill in the art (and is not to be limited to a special or customized meaning), and furthermore refers without limitation to a general integral transform that is defined by  $g(\alpha) = \int_a^b f(t)K(\alpha, t)dt$ , where  $K(\alpha, t)$  represents a set of orthogonal basis functions.

[0168] The term “Fourier Transform” as used herein is a broad term and is to be given its ordinary and customary meaning to a person of ordinary skill in the art (and is not to be limited to a special or customized meaning), and furthermore refers without limitation to a technique for expressing a waveform as a weighted sum of sines and cosines.

[0169] The term “Discrete Fourier Transform” as used herein is a broad term and is to be given its ordinary and customary meaning to a person of ordinary skill in the art (and is not to be limited to a special or customized meaning), and furthermore refers without limitation to a specialized Fourier transform where the variables are discrete.

[0170] The term “wavelet transform” as used herein is a broad term and is to be given its ordinary and customary meaning to a person of ordinary skill in the art (and is not to be limited to a special or customized meaning), and furthermore refers without limitation to a transform which converts a signal into a series of wavelets, which in theory allows signals processed by the wavelet transform to be stored more efficiently than ones processed by Fourier

transform. Wavelets can also be constructed with rough edges, to better approximate real-world signals.

[0171] The term “chronoamperometry” as used herein is a broad term and is to be given its ordinary and customary meaning to a person of ordinary skill in the art (and is not to be limited to a special or customized meaning), and furthermore refers without limitation to an electrochemical measuring technique used for electrochemical analysis or for the determination of the kinetics and mechanism of electrode reactions. A fast-rising potential pulse is enforced on the working (or reference) electrode of an electrochemical cell and the current flowing through this electrode is measured as a function of time.

[0172] The term “pulsed amperometric detection” as used herein is a broad term and is to be given its ordinary and customary meaning to a person of ordinary skill in the art (and is not to be limited to a special or customized meaning), and furthermore refers without limitation to an electrochemical flow cell and a controller, which applies the potentials and monitors current generated by the electrochemical reactions. The cell can include one or multiple working electrodes at different applied potentials. Multiple electrodes can be arranged so that they face the chromatographic flow independently (parallel configuration), or sequentially (series configuration).

[0173] The term “linear regression” as used herein is a broad term and is to be given its ordinary and customary meaning to a person of ordinary skill in the art (and is not to be limited to a special or customized meaning), and furthermore refers without limitation to finding a line in which a set of data has a minimal measurement from that line. Byproducts of this algorithm include a slope, a y-intercept, and an R-Squared value that determine how well the measurement data fits the line.

[0174] The term “non-linear regression” as used herein is a broad term and is to be given its ordinary and customary meaning to a person of ordinary skill in the art (and is not to be limited to a special or customized meaning), and furthermore refers without limitation to fitting a set of data to describe the relationship between a response variable and one or more explanatory variables in a non-linear fashion.

[0175] The term “mean” as used herein is a broad term and is to be given its ordinary and customary meaning to a person of ordinary skill in the art (and is not to be limited to a special or customized meaning), and furthermore refers without limitation to the sum of the observations divided by the number of observations.

[0176] The term “trimmed mean” as used herein is a broad term and is to be given its ordinary and customary meaning to a person of ordinary skill in the art (and is not to be limited to a special or customized meaning), and furthermore refers without limitation to a mean taken after extreme values in the tails of a variable (e.g., highs and lows) are eliminated or reduced (e.g., “trimmed”). The trimmed mean compensates for sensitivities to extreme values by dropping a certain percentage of values on the tails. For example, the 50% trimmed mean is the mean of the values between the upper and lower quartiles. The 90% trimmed mean is the mean of the values after truncating the lowest and highest 5% of the values. In one example, two highest and two lowest measurements are removed from a data set and then the remaining measurements are averaged.



[0177] The term “non-recursive filter” as used herein is a broad term and is to be given its ordinary and customary meaning to a person of ordinary skill in the art (and is not to be limited to a special or customized meaning), and furthermore refers without limitation to an equation that uses moving averages as inputs and outputs.

[0178] The terms “recursive filter” and “auto-regressive algorithm” as used herein are broad terms and are to be given their ordinary and customary meaning to a person of ordinary skill in the art (and are not to be limited to a special or customized meaning), and furthermore refer without limitation to an equation in which includes previous averages are part of the next filtered output. More particularly, the generation of a series of observations whereby the value of each observation is partly dependent on the values of those that have immediately preceded it. One example is a regression structure in which lagged response values assume the role of the independent variables.

[0179] The term “signal estimation algorithm factors” as used herein is a broad term and is to be given its ordinary and customary meaning to a person of ordinary skill in the art (and is not to be limited to a special or customized meaning), and furthermore refers without limitation to one or more algorithms that use historical and/or present signal data stream values to estimate unknown signal data stream values. For example, signal estimation algorithm factors can include one or more algorithms, such as linear or non-linear regression. As another example, signal estimation algorithm factors can include one or more sets of coefficients that can be applied to one algorithm.

[0180] The term “variation” as used herein is a broad term and is to be given its ordinary and customary meaning to a person of ordinary skill in the art (and is not to be limited to a special or customized meaning), and furthermore refers without limitation to a divergence or amount of change from a point, line, or set of data. In one embodiment, estimated analyte values can have a variation including a range of values outside of the estimated analyte values that represent a range of possibilities based on known physiological patterns, for example.

[0181] The terms “physiological parameters” and “physiological boundaries” as used herein are broad terms and are to be given their ordinary and customary meaning to a person of ordinary skill in the art (and are not to be limited to a special or customized meaning), and furthermore refer without limitation to the parameters obtained from continuous studies of physiological data in humans and/or animals. For example, a maximal sustained rate of change of glucose in humans of about 4 to 5 mg/dL/min and a maximum acceleration of the rate of change of about 0.1 to 0.2 mg/dL/min are deemed physiologically feasible limits; values outside of these limits would be considered non-physiological. As another example, the rate of change of glucose is lowest at the maxima and minima of the daily glucose range, which are the areas of greatest risk in patient treatment, thus a physiologically feasible rate of change can be set at the maxima and minima based on continuous studies of glucose data. As a further example, it has been observed that the best solution for the shape of the curve at any point along glucose signal data stream over a certain time period (for example, about 20 to 30 minutes) is a straight line,

which can be used to set physiological limits. These terms are broad enough to include physiological parameters for any analyte.

[0182] The term “measured analyte values” as used herein is a broad term and is to be given its ordinary and customary meaning to a person of ordinary skill in the art (and is not to be limited to a special or customized meaning), and furthermore refers without limitation to an analyte value or set of analyte values for a time period for which analyte data has been measured by an analyte sensor. The term is broad enough to include data from the analyte sensor before or after data processing in the sensor and/or receiver (for example, data smoothing, calibration, and the like).

[0183] The term “estimated analyte values” as used herein is a broad term and is to be given its ordinary and customary meaning to a person of ordinary skill in the art (and is not to be limited to a special or customized meaning), and furthermore refers without limitation to an analyte value or set of analyte values, which have been algorithmically extrapolated from measured analyte values. Typically, estimated analyte values are estimated for a time period during which no data exists. However, estimated analyte values can also be estimated during a time period for which measured data exists, but is to be replaced by algorithmically extrapolated (e.g. processed or filtered) data due to noise or a time lag in the measured data, for example.

[0184] The terms “interferants” and “interfering species” as used herein are broad terms and are to be given their ordinary and customary meaning to a person of ordinary skill in the art (and are not to be limited to a special or customized meaning), and furthermore refer without limitation to effects and/or species that interfere with the measurement of an analyte of interest in a sensor to produce a signal that does not accurately represent the analyte concentration. In one example of an electrochemical sensor, interfering species are compounds with an oxidation potential that overlap that of the analyte to be measured, thereby producing a false positive signal.

[0185] As employed herein, the following abbreviations apply: Eq and Eqs (equivalents); mEq (milliequivalents); M (molar); mM (millimolar);  $\mu$ M (micromolar); N (Normal); mol (moles); mmol (millimoles);  $\mu$ mol (micromoles); nmol (nanomoles); g (grams); mg (milligrams);  $\mu$ g (micrograms); Kg (kilograms); L (liters); mL (milliliters); dL (deciliters);  $\mu$ L (microliters); cm (centimeters); mm (millimeters);  $\mu$ m (micrometers); nm (nanometers); h and hr (hours); min. (minutes); s and sec. (seconds); ° C. (degrees Centigrade).

#### Overview

[0186] The preferred embodiments relate to the use of a glucose sensor that measures a concentration of glucose or a substance indicative of the concentration or presence of the glucose. In some embodiments, the glucose sensor is a continuous device, for example a subcutaneous, transdermal, or intravascular device. In some embodiments, the device can analyze a plurality of intermittent blood samples. The glucose sensor can use any method of glucose-measurement, including enzymatic, chemical, physical, electrochemical, spectrophotometric, polarimetric, calorimetric, iontophoretic, radiometric, and the like.

[0187] The glucose sensor can use any known method, including invasive, minimally invasive, and non-invasive

sensing techniques, to provide a data stream indicative of the concentration of glucose in a host. The data stream is typically a raw data signal that is used to provide a useful value of glucose to a user, such as a patient or doctor, who may be using the sensor. It is well known that raw data streams typically include system noise such as defined herein; however the preferred embodiments address the detection and replacement of "signal artifacts" as defined herein. Accordingly, appropriate signal estimation (e.g., filtering, data smoothing, augmenting, projecting, and/or other methods) replace such erroneous signals (e.g., signal artifacts) in the raw data stream. Glucose Sensor

[0188] The glucose sensor can be any device capable of measuring the concentration of glucose. One exemplary embodiment is described below, which utilizes an implantable glucose sensor. However, it should be understood that the devices and methods described herein can be applied to any device capable of detecting a concentration of glucose and providing an output signal that represents the concentration of glucose.

[0189] In one preferred embodiment, the analyte sensor is an implantable glucose sensor, such as described with reference to U.S. Pat. No. 6,001,067 and U.S. Publication No. US-2005-0027463-A1. In another preferred embodiment, the analyte sensor is a transcutaneous glucose sensor, such as described with reference to U.S. Publication No. US-2006-0020187-A1. In one alternative embodiment, the continuous glucose sensor comprises a transcutaneous sensor such as described in U.S. Pat. No. 6,565,509 to Say et al., for example. In another alternative embodiment, the continuous glucose sensor comprises a subcutaneous sensor such as described with reference to U.S. Pat. No. 6,579,690 to Bonnacaze et al. or U.S. Pat. No. 6,484,046 to Say et al., for example. In another alternative embodiment, the continuous glucose sensor comprises a refillable subcutaneous sensor such as described with reference to U.S. Pat. No. 6,512,939 to Colvin et al., for example. In another alternative embodiment, the continuous glucose sensor comprises an intravascular sensor such as described with reference to U.S. Pat. No. 6,477,395 to Schulman et al., for example. In another alternative embodiment, the continuous glucose sensor comprises an intravascular sensor such as described with reference to U.S. Pat. No. 6,424,847 to Mastrototaro et al.

[0190] FIG. 1A is an exploded perspective view of one exemplary embodiment comprising an implantable glucose sensor **10** that utilizes amperometric electrochemical sensor technology to measure glucose concentration. In this exemplary embodiment, a body **12** and head **14** house the electrodes **16** and sensor electronics, which are described in more detail below with reference to FIG. 2. Three electrodes **16** are operably connected to the sensor electronics (FIG. 2) and are covered by a sensing membrane **17** and a biointerface membrane **18**, which are attached by a clip **19**.

[0191] In one embodiment, the three electrodes **16**, which protrude through the head **14**, include a platinum working electrode, a platinum counter electrode, and a silver/silver chloride reference electrode. The top ends of the electrodes are in contact with an electrolyte phase (not shown), which is a free-flowing fluid phase disposed between the sensing membrane **17** and the electrodes **16**. The sensing membrane **17** includes an enzyme, e.g., glucose oxidase, which covers

the electrolyte phase. The biointerface membrane **18** covers the sensing membrane **17** and serves, at least in part, to protect the sensor **10** from external forces that can result in environmental stress cracking of the sensing membrane **17**.

[0192] In the illustrated embodiment, the counter electrode is provided to balance the current generated by the species being measured at the working electrode. In the case of a glucose oxidase based glucose sensor, the species being measured at the working electrode is  $H_2O_2$ . Glucose oxidase catalyzes the conversion of oxygen and glucose to hydrogen peroxide and gluconate according to the following reaction:

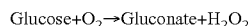

[0193] The change in  $H_2O_2$  can be monitored to determine glucose concentration because for each glucose molecule metabolized, there is a proportional change in the product  $H_2O_2$ . Oxidation of  $H_2O_2$  by the working electrode is balanced by reduction of ambient oxygen, enzyme generated  $H_2O_2$ , or other reducible species at the counter electrode. The  $H_2O_2$  produced from the glucose oxidase reaction further reacts at the surface of working electrode and produces two protons ( $2H^+$ ), two electrons ( $2e^-$ ), and one oxygen molecule ( $O_2$ ).

[0194] FIG. 1B is side view of a distal portion of a transcutaneously-inserted sensor **100** in one embodiment, showing working and reference electrodes. In preferred embodiments, the sensor **100** is formed from a working electrode **244** and a reference electrode **246** helically wound around the working electrode **244**. An insulator **245** is disposed between the working and reference electrodes to provide necessary electrical insulation therebetween. Certain portions of the electrodes are exposed to enable electrochemical reaction thereon, for example, a window **243** can be formed in the insulator to expose a portion of the working electrode **244** for electrochemical reaction.

[0195] In preferred embodiments, each electrode is formed from a fine wire with a diameter of from about 0.001 or less to about 0.010 inches or more, for example, and is formed from, e.g., a plated insulator, a plated wire, or bulk electrically conductive material. Although the illustrated electrode configuration and associated text describe one preferred method of forming a transcutaneous sensor, a variety of known transcutaneous sensor configurations can be employed with the transcutaneous analyte sensor system of the preferred embodiments, such as are described in U.S. Pat. No. 6,695,860 to Ward et al., U.S. Pat. No. 6,565,509 to Say et al., U.S. Pat. No. 6,248,067 to Causey III, et al., and U.S. Pat. No. 6,514,718 to Heller et al.

[0196] In preferred embodiments, the working electrode comprises a wire formed from a conductive material, such as platinum, platinum-iridium, palladium, graphite, gold, carbon, conductive polymer, alloys, and the like. Although the electrodes can be formed by a variety of manufacturing techniques (bulk metal processing, deposition of metal onto a substrate, and the like), it can be advantageous to form the electrodes from plated wire (e.g., platinum on steel wire) or bulk metal (e.g., platinum wire). It is believed that electrodes formed from bulk metal wire provide superior performance (e.g., in contrast to deposited electrodes), including increased stability of assay, simplified manufacturability, resistance to contamination (e.g., which can be introduced in deposition processes), and improved surface reaction (e.g., due to purity of material) without peeling or delamination.

[0197] The working electrode **244** is configured to measure the concentration of an analyte. In an enzymatic electrochemical sensor for detecting glucose, for example, the working electrode measures the hydrogen peroxide produced by an enzyme catalyzed reaction of the analyte being detected and creates a measurable electronic current. For example, in the detection of glucose wherein glucose oxidase produces hydrogen peroxide as a byproduct, hydrogen peroxide reacts with the surface of the working electrode producing two protons ( $2\text{H}^+$ ), two electrons ( $2\text{e}^-$ ) and one molecule of oxygen ( $\text{O}_2$ ), which produces the electronic current being detected.

[0198] In preferred embodiments, the working electrode **244** is covered with an insulating material **45**, for example, a non-conductive polymer. Dip-coating, spray-coating, vapor-deposition, or other coating or deposition techniques can be used to deposit the insulating material on the working electrode. In one embodiment, the insulating material comprises parylene, which can be an advantageous polymer coating for its strength, lubricity, and electrical insulation properties. Generally, parylene is produced by vapor deposition and polymerization of para-xylylene (or its substituted derivatives). However, any suitable insulating material can be used, for example, fluorinated polymers, polyethylene-terephthalate, polyurethane, polyimide, other nonconducting polymers, and the like. Glass or ceramic materials can also be employed. Other materials suitable for use include surface energy modified coating systems such as are marketed under the trade names AMC18, AMC148, AMC141, and AMC321 by Advanced Materials Components Express of Bellafonte, Pa. In some alternative embodiments, however, the working electrode may not require a coating of insulator.

[0199] The reference electrode **246**, which can function as a reference electrode alone, or as a dual reference and counter electrode, is formed from silver, silver/silver chloride, and the like. Preferably, the reference electrode **246** is juxtapositioned and/or twisted with or around the working electrode **244**; however other configurations are also possible. In the illustrated embodiments, the reference electrode **246** is helically wound around the working electrode **244**. The assembly of wires is then optionally coated or adhered together with an insulating material, similar to that described above, so as to provide an insulating attachment.

[0200] In embodiments wherein an outer insulator is disposed, a portion of the coated assembly structure can be stripped or otherwise removed, for example, by hand, excimer lasing, chemical etching, laser ablation, grit-blasting (e.g., with sodium bicarbonate or other suitable grit), and the like, to expose the electroactive surfaces. Alternatively, a portion of the electrode can be masked prior to depositing the insulator in order to maintain an exposed electroactive surface area. In one exemplary embodiment, grit blasting is implemented to expose the electroactive surfaces, preferably utilizing a grit material that is sufficiently hard to ablate the polymer material, while being sufficiently soft so as to minimize or avoid damage to the underlying metal electrode (e.g., a platinum electrode). Although a variety of "grit" materials can be used (e.g., sand, talc, walnut shell, ground plastic, sea salt, and the like), in some preferred embodiments, sodium bicarbonate is an advantageous grit-material because it is sufficiently hard to ablate, e.g., a parylene coating without damaging, e.g., an underlying platinum conductor. One additional advantage of sodium bicarbonate

blasting includes its polishing action on the metal as it strips the polymer layer, thereby eliminating a cleaning step that might otherwise be necessary.

[0201] In the embodiment illustrated in FIG. 1B, a radial window **243** is formed through the insulating material **245** to expose a circumferential electroactive surface of the working electrode. Additionally, sections **241** of electroactive surface of the reference electrode are exposed. For example, the 241 sections of electroactive surface can be masked during deposition of an outer insulating layer or etched after deposition of an outer insulating layer.

[0202] In some applications, cellular attack or migration of cells to the sensor can cause reduced sensitivity and/or function of the device, particularly after the first day of implantation. However, when the exposed electroactive surface is distributed circumferentially about the sensor (e.g., as in a radial window), the available surface area for reaction can be sufficiently distributed so as to minimize the effect of local cellular invasion of the sensor on the sensor signal. Alternatively, a tangential exposed electroactive window can be formed, for example, by stripping only one side of the coated assembly structure. In other alternative embodiments, the window can be provided at the tip of the coated assembly structure such that the electroactive surfaces are exposed at the tip of the sensor. Other methods and configurations for exposing electroactive surfaces can also be employed.

[0203] In some embodiments, the working electrode has a diameter of from about 0.001 inches or less to about 0.010 inches or more, preferably from about 0.002 inches to about 0.008 inches, and more preferably from about 0.004 inches to about 0.005 inches. The length of the window can be from about 0.1 mm (about 0.004 inches) or less to about 2 mm (about 0.078 inches) or more, and preferably from about 0.5 mm (about 0.02 inches) to about 0.75 mm (0.03 inches). In such embodiments, the exposed surface area of the working electrode is preferably from about 0.000013 in<sup>2</sup> (0.0000839 cm<sup>2</sup>) or less to about 0.0025 in<sup>2</sup> (0.016129 cm<sup>2</sup>) or more (assuming a diameter of from about 0.001 inches to about 0.010 inches and a length of from about 0.004 inches to about 0.078 inches). The preferred exposed surface area of the working electrode is selected to produce an analyte signal with a current in the picoAmp range, such as is described in more detail elsewhere herein. However, a current in the picoAmp range can be dependent upon a variety of factors, for example the electronic circuitry design (e.g., sample rate, current draw, A/D converter bit resolution, etc.), the membrane system (e.g., permeability of the analyte through the membrane system), and the exposed surface area of the working electrode. Accordingly, the exposed electroactive working electrode surface area can be selected to have a value greater than or less than the above-described ranges taking into consideration alterations in the membrane system and/or electronic circuitry. In preferred embodiments of a glucose sensor, it can be advantageous to minimize the surface area of the working electrode while maximizing the diffusivity of glucose in order to optimize the signal-to-noise ratio while maintaining sensor performance in both high and low glucose concentration ranges.

[0204] In some alternative embodiments, the exposed surface area of the working (and/or other) electrode can be increased by altering the cross-section of the electrode itself.

For example, in some embodiments the cross-section of the working electrode can be defined by a cross, star, cloverleaf, ribbed, dimpled, ridged, irregular, or other non-circular configuration; thus, for any predetermined length of electrode, a specific increased surface area can be achieved (as compared to the area achieved by a circular cross-section). Increasing the surface area of the working electrode can be advantageous in providing an increased signal responsive to the analyte concentration, which in turn can be helpful in improving the signal-to-noise ratio, for example.

[0205] In some alternative embodiments, additional electrodes can be included within the assembly, for example, a three-electrode system (working, reference, and counter electrodes) and/or an additional working electrode (e.g., an electrode which can be used to generate oxygen, which is configured as a baseline subtracting electrode, or which is configured for measuring additional analytes). U.S. Publication No. US-2005-0161346-A1 and U.S. Publication No. US-2005-0143635-A1 describe some systems and methods for implementing and using additional working, counter, and/or reference electrodes. In one implementation wherein the sensor comprises two working electrodes, the two working electrodes are juxtapositioned (e.g., extend parallel to each other), around which the reference electrode is disposed (e.g., helically wound). In some embodiments wherein two or more working electrodes are provided, the working electrodes can be formed in a double-, triple-, quad-, etc. helix configuration along the length of the sensor (for example, surrounding a reference electrode, insulated rod, or other support structure). The resulting electrode system can be configured with an appropriate membrane system, wherein the first working electrode is configured to measure a first signal comprising glucose and baseline and the additional working electrode is configured to measure a baseline signal consisting of baseline only (e.g., configured to be substantially similar to the first working electrode without an enzyme disposed thereon). In this way, the baseline signal can be subtracted from the first signal to produce a glucose-only signal that is substantially not subject to fluctuations in the baseline and/or interfering species on the signal.

[0206] Although the preferred embodiments illustrate one electrode configuration including one bulk metal wire helically wound around another bulk metal wire, other electrode configurations are also contemplated. In an alternative embodiment, the working electrode comprises a tube with a reference electrode disposed or coiled inside, including an insulator therebetween. Alternatively, the reference electrode comprises a tube with a working electrode disposed or coiled inside, including an insulator therebetween. In another alternative embodiment, a polymer (e.g., insulating) rod is provided, wherein the electrodes are deposited (e.g., electro-plated) thereon. In yet another alternative embodiment, a metallic (e.g., steel) rod is provided, coated with an insulating material, onto which the working and reference electrodes are deposited. In yet another alternative embodiment, one or more working electrodes are helically wound around a reference electrode.

[0207] Preferably, the electrodes and membrane systems of the preferred embodiments are coaxially formed, namely, the electrodes and/or membrane system all share the same central axis. While not wishing to be bound by theory, it is believed that a coaxial design of the sensor enables a

symmetrical design without a preferred bend radius. Namely, in contrast to prior art sensors comprising a substantially planar configuration that can suffer from regular bending about the plane of the sensor, the coaxial design of the preferred embodiments do not have a preferred bend radius and therefore are not subject to regular bending about a particular plane (which can cause fatigue failures and the like). However, non-coaxial sensors can be implemented with the sensor system of the preferred embodiments.

[0208] In addition to the above-described advantages, the coaxial sensor design of the preferred embodiments enables the diameter of the connecting end of the sensor (proximal portion) to be substantially the same as that of the sensing end (distal portion) such that the needle is able to insert the sensor into the host and subsequently slide back over the sensor and release the sensor from the needle, without slots or other complex multi-component designs.

[0209] In one such alternative embodiment, the two wires of the sensor are held apart and configured for insertion into the host in proximal but separate locations. The separation of the working and reference electrodes in such an embodiment can provide additional electrochemical stability with simplified manufacture and electrical connectivity. It is appreciated by one skilled in the art that a variety of electrode configurations can be implemented with the preferred embodiments.

[0210] Preferably, a membrane system is deposited over the electroactive surfaces of the sensor **100** and includes a plurality of domains or layers. The membrane system may be deposited on the exposed electroactive surfaces using known thin film techniques (for example, spraying, electro-depositing, dipping, and the like). In one exemplary embodiment, each domain is deposited by dipping the sensor into a solution and drawing out the sensor at a speed that provides the appropriate domain thickness. In general, the membrane system may be disposed over (deposited on) the electroactive surfaces using methods appreciated by one skilled in the art.

[0211] In one exemplary embodiment, the sensor is an enzyme-based electrochemical sensor, wherein the glucose-measuring working electrode measures the hydrogen peroxide produced by the enzyme catalyzed reaction of glucose being detected and creates a measurable electronic current (for example, detection of glucose utilizing glucose oxidase produces  $H_2O_2$  peroxide as a by product,  $H_2O_2$  reacts with the surface of the working electrode producing two protons ( $2H^+$ ), two electrons ( $2e^-$ ) and one molecule of oxygen ( $O_2$ ) which produces the electronic current being detected), such as described in more detail above and as is appreciated by one skilled in the art. Typically, the working and reference electrodes operatively connect with sensor electronics, such as described in more detail elsewhere herein. Additional aspects of the above-described transcatheter inserted sensor can be found in co-pending U.S. Publication No. US-2006-0020187-A1.

[0212] In some embodiments (e.g., sensors such as illustrated in FIGS. 1A and 1B), a potentiostat is employed to monitor the electrochemical reaction at the electrochemical cell. The potentiostat applies a constant potential to the working and reference electrodes to determine a current value. The current that is produced at the working electrode (and flows through the circuitry to the counter electrode) is

proportional to the amount of  $H_2O_2$  that diffuses to the working electrode. Accordingly, a raw signal can be produced that is representative of the concentration of glucose in the user's body, and therefore can be utilized to estimate a meaningful glucose value, such as described herein.

[0213] One problem with raw data stream output of enzymatic glucose sensors such as described above is caused by transient non-glucose reaction rate-limiting phenomenon. For example, if oxygen is deficient, relative to the amount of glucose, then the enzymatic reaction will be limited by oxygen rather than glucose. Consequently, the output signal will be indicative of the oxygen concentration rather than the glucose concentration, producing erroneous signals. Other non-glucose reaction rate-limiting phenomenon could include interfering species, temperature and/or pH changes, or even unknown sources of mechanical, electrical and/or biochemical noise, for example. Accordingly, reduction of signal noise, and particularly replacement of transient non-glucose related signal artifacts in the data stream that have a higher amplitude than system noise, can be performed in the sensor and/or in the receiver, such as described in more detail below in the sections entitled "Signal Artifacts Detection" and "Signal Artifacts Replacement," for example.

[0214] FIG. 2 is a block diagram that illustrates one possible configuration of the sensor electronics in one embodiment. In this embodiment, a potentiostat 20 is shown, which is operatively connected to an electrode system (FIG. 1A or 1B) and provides a voltage to the electrodes, which biases the sensor to enable measurement of a current value indicative of the analyte concentration in the host (also referred to as the analog portion). In some embodiments, the potentiostat includes a resistor (not shown) that translates the current into voltage. In some alternative embodiments, a current to frequency converter is provided that is configured to continuously integrate the measured current, for example, using a charge counting device. In the illustrated embodiment, an A/D converter 21 digitizes the analog signal into "counts" for processing. Accordingly, the resulting raw data stream in counts is directly related to the current measured by the potentiostat 20.

[0215] A processor module 22 is the central control unit that controls the processing of the sensor electronics. In some embodiments, the processor module includes a micro-processor, however a computer system other than a micro-processor can be used to process data as described herein, for example an ASIC can be used for some or all of the sensor's central processing. The processor typically provides semi-permanent storage of data, for example, storing data such as sensor identifier (ID) and programming to process data streams (for example, programming for data smoothing and/or replacement of signal artifacts such as is described in more detail elsewhere herein). The processor additionally can be used for the system's cache memory, for example for temporarily storing recent sensor data. In some embodiments, the processor module comprises memory storage components such as ROM, RAM, dynamic-RAM, static-RAM, non-static RAM, EEPROM, rewritable ROMs, flash memory, and the like. In one exemplary embodiment, EEPROM 23 provides semi-permanent storage of data, for example, storing data such as sensor identifier (ID) and programming to process data streams (e.g., programming for signal artifacts detection and/or replacement such as

described elsewhere herein). In one exemplary embodiment, SRAM 24 can be used for the system's cache memory, for example for temporarily storing recent sensor data.

[0216] In some embodiments, the processor module comprises a digital filter, for example, an IIR or FIR filter, configured to smooth the raw data stream from the A/D converter. Generally, digital filters are programmed to filter data sampled at a predetermined time interval (also referred to as a sample rate). In some embodiments, wherein the potentiostat is configured to measure the analyte at discrete time intervals, these time intervals determine the sample rate of the digital filter. In some alternative embodiments, wherein the potentiostat is configured to continuously measure the analyte, for example, using a current-to-frequency converter, the processor module can be programmed to request a digital value from the A/D converter at a predetermined time interval, also referred to as the acquisition time. In these alternative embodiments, the values obtained by the processor are advantageously averaged over the acquisition time due to the continuity of the current measurement. Accordingly, the acquisition time determines the sample rate of the digital filter. In preferred embodiments, the processor module is configured with a programmable acquisition time, namely, the predetermined time interval for requesting the digital value from the A/D converter is programmable by a user within the digital circuitry of the processor module. An acquisition time of from about 2 seconds to about 512 seconds is preferred; however any acquisition time can be programmed into the processor module. A programmable acquisition time is advantageous in optimizing noise filtration, time lag, and processing/battery power.

[0217] Preferably, the processor module is configured to build the data packet for transmission to an outside source, for example, an RF transmission to a receiver as described in more detail below. Generally, the data packet comprises a plurality of bits that can include a sensor ID code, raw data, filtered data, and/or error detection or correction. The processor module can be configured to transmit any combination of raw and/or filtered data.

[0218] A battery 25 is operatively connected to the processor 22 and provides the necessary power for the sensor (e.g., 10 or 100). In one embodiment, the battery is a Lithium Manganese Dioxide battery, however any appropriately sized and powered battery can be used (e.g., AAA, Nickel-cadmium, Zinc-carbon, Alkaline, Lithium, Nickel-metal hydride, Lithium-ion, Zinc-air, Zinc-mercury oxide, Silver-zinc, or hermetically-sealed). In some embodiments the battery is rechargeable. In some embodiments, a plurality of batteries can be used to power the system. In yet other embodiments, the receiver can be transcutaneously powered via an inductive coupling, for example. A Quartz Crystal 26 is operatively connected to the processor 22 and maintains system time for the computer system as a whole.

[0219] An RF module, (e.g., an RF Transceiver) 27 is operably connected to the processor 22 and transmits the sensor data from the sensor (e.g., 10 or 100) to a receiver (see FIGS. 3 and 4). Although an RF transceiver is shown here, some other embodiments can include a wired rather than wireless connection to the receiver. A second quartz crystal 28 provides the system time for synchronizing the data transmissions from the RF transceiver. It is noted that

the transceiver 27 can be substituted with a transmitter in other embodiments. In some alternative embodiments, however, other mechanisms, such as optical, infrared radiation (1R), ultrasonic, and the like, can be used to transmit and/or receive data.

[0220] In some embodiments, a Signal Artifacts Detector 29 is provided that includes one or more of the following: an oxygen detector 29a, a pH detector 29b, a temperature detector 29c, and a pressure/stress detector 29d, which is described in more detail with reference to signal artifacts detection. It is noted that in some embodiments the signal artifacts detector 29 is a separate entity (e.g., temperature detector) operatively connected to the processor, while in other embodiments, the signal artifacts detector is a part of the processor and utilizes readings from the electrodes, for example, to detect ischemia and other signal artifacts. Although the above description is focused on an embodiment of the Signal Artifacts Detector within the sensor, some embodiments provide for systems and methods for detecting signal artifacts in the sensor and/or receiver electronics (e.g., processor module) as described in more detail elsewhere herein.

#### Receiver

[0221] FIGS. 3A to 3D are schematic views of a receiver 30 including representations of estimated glucose values on its user interface in first, second, third, and fourth embodiments, respectively. The receiver 30 comprises systems to receive, process, and display sensor data from the glucose sensor (e.g., 10 or 100), such as described herein. Particularly, the receiver 30 can be a pager-sized device, for example, and comprise a user interface that has a plurality of buttons 32 and a liquid crystal display (LCD) screen 34, and which can optionally include a backlight. In some embodiments, the user interface can also include a keyboard, a speaker, and a vibrator, as described below with reference to FIG. 4A.

[0222] FIG. 3A illustrates a first embodiment wherein the receiver 30 shows a numeric representation of the estimated glucose value on its user interface, which is described in more detail elsewhere herein.

[0223] FIG. 3B illustrates a second embodiment wherein the receiver 30 shows an estimated glucose value and approximately one hour of historical trend data on its user interface, which is described in more detail elsewhere herein.

[0224] FIG. 3C illustrates a third embodiment wherein the receiver 30 shows an estimated glucose value and approximately three hours of historical trend data on its user interface, which is described in more detail elsewhere herein.

[0225] FIG. 3D illustrates a fourth embodiment wherein the receiver 30 shows an estimated glucose value and approximately nine hours of historical trend data on its user interface, which is described in more detail elsewhere herein.

[0226] In some embodiments, a user can toggle through some or all of the screens shown in FIGS. 3A to 3D using a toggle button on the receiver. In some embodiments, the user will be able to interactively select the type of output

displayed on their user interface. In other embodiments, the sensor output can have alternative configurations.

[0227] FIG. 4A is a block diagram that illustrates one possible configuration of the receiver's 30 electronics. It is noted that the receiver 30 can comprise a configuration such as described with reference to FIGS. 3A to 3D, above. Alternatively, the receiver 30 can comprise other configurations, including a desktop computer, laptop computer, a personal digital assistant (PDA), a server (local or remote to the receiver), and the like. In some embodiments, the receiver 30 can be adapted to connect (via wired or wireless connection) to a desktop computer, laptop computer, PDA, server (local or remote to the receiver), and the like, in order to download data from the receiver 30. In some alternative embodiments, the receiver 30 and/or receiver electronics can be housed within or directly connected to the sensor (e.g., 10 or 100) in a manner that allows sensor and receiver electronics to work directly together and/or share data processing resources. Accordingly, the receiver's electronics can be generally referred to as a "computer system."

[0228] A quartz crystal 40 is operatively connected to an RF transceiver 41 that together function to receive and synchronize data streams (e.g., raw data streams transmitted from the RF transceiver). Once received, a processor 42 processes the signals, such as described below.

[0229] The processor 42, also referred to as the processor module, is the central control unit that performs the processing, such as storing data, analyzing data streams, calibrating analyte sensor data, estimating analyte values, comparing estimated analyte values with time corresponding measured analyte values, analyzing a variation of estimated analyte values, downloading data, and controlling the user interface by providing analyte values, prompts, messages, warnings, alarms, and the like. The processor includes hardware and software that performs the processing described herein, for example flash memory provides permanent or semi-permanent storage of data, storing data such as sensor ID, receiver ID, and programming to process data streams (for example, programming for performing estimation and other algorithms described elsewhere herein) and random access memory (RAM) stores the system's cache memory and is helpful in data processing.

[0230] In one exemplary embodiment, the processor is a microprocessor that provides the processing, such as calibration algorithms stored within an EEPROM 43. The EEPROM 43 is operatively connected to the processor 42 and provides semi-permanent storage of data, storing data such as receiver ID and programming to process data streams (e.g., programming for performing calibration and other algorithms described elsewhere herein). In this exemplary embodiment, an SRAM 44 is used for the system's cache memory and is helpful in data processing.

[0231] A battery 45 is operatively connected to the processor 42 and provides power for the receiver. In one embodiment, the battery is a standard AAA alkaline battery, however any appropriately sized and powered battery can be used. In some embodiments, a plurality of batteries can be used to power the system. A quartz crystal 46 is operatively connected to the processor 42 and maintains system time for the computer system as a whole.

[0232] A user interface 47 comprises a keyboard 2, speaker 3, vibrator 4, backlight 5, liquid crystal display

(LCD 6), and one or more buttons 7. The components that comprise the user interface 47 provide controls to interact with the user. The keyboard 2 can allow, for example, input of user information about himself/herself, such as mealtime, exercise, insulin administration, and reference glucose values. The speaker 3 can provide, for example, audible signals or alerts for conditions such as present and/or predicted hyper- and hypoglycemic conditions. The vibrator 4 can provide, for example, tactile signals or alerts for reasons such as described with reference to the speaker, above. The backlight 5 can be provided, for example, to aid the user in reading the LCD in low light conditions. The LCD 6 can be provided, for example, to provide the user with visual data output such as is illustrated in FIGS. 3A to 3D. The buttons 7 can provide for toggle, menu selection, option selection, mode selection, and reset, for example.

[0233] In some embodiments, prompts or messages can be displayed on the user interface to convey information to the user, such as reference outlier values, requests for reference analyte values, therapy recommendations, deviation of the measured analyte values from the estimated analyte values, and the like. Additionally, prompts can be displayed to guide the user through calibration or trouble-shooting of the calibration.

#### Input and Output

[0234] In general, the above-described estimative algorithms, including estimation of measured analyte values and variation analysis of the estimated analyte values are useful when provided to a patient, doctor, family member, and the like. Even more, the estimative algorithms are useful when they are able to provide information helpful in modifying a patient's behavior so that they experience less clinically risky situations and higher quality of life than may otherwise be possible. Therefore, the above-described data analysis can be output in a variety of forms useful in caring for the health of a patient.

[0235] Output can be provided via a user interface, including but not limited to, visually on a screen, audibly through a speaker, or tactilely through a vibrator. Additionally, output can be provided via wired or wireless connection to an external device, including but not limited to, computer, laptop, server, personal digital assistant, modem connection, insulin delivery mechanism, medical device, or other device that can be useful in interfacing with the receiver.

[0236] Output can be continuously provided, or certain output can be selectively provided based on events, analyte concentrations and the like. For example, an estimated analyte path can be continuously provided to a patient on an LCD screen, while audible alerts can be provided only during a time of existing or approaching clinical risk to a patient. As another example, estimation can be provided based on event triggers (for example, when an analyte concentration is nearing or entering a clinically risky zone). As yet another example, analyzed deviation of estimated analyte values can be provided when a predetermined level of variation (for example, due to known error or clinical risk) is known.

[0237] In some embodiments, alarms prompt or alert a patient when a measured or projected analyte value or rate of change simply passes a predetermined threshold. In some embodiments, the clinical risk alarms combine intelligent

and dynamic estimative algorithms to provide greater accuracy, more timeliness in pending danger, avoidance of false alarms, and less annoyance for the patient. For example, clinical risk alarms of these embodiments include dynamic and intelligent estimative algorithms based on analyte value, rate of change, acceleration, clinical risk, statistical probabilities, known physiological constraints, and/or individual physiological patterns, thereby providing more appropriate, clinically safe, and patient-friendly alarms.

[0238] In some embodiments, clinical risk alarms can be activated for a predetermined time period to allow for the user to attend to his/her condition. Additionally, the clinical risk alarms can be de-activated when leaving a clinical risk zone so as not to annoy the patient by repeated clinical risk alarms, when the patient's condition is improving.

[0239] In some embodiments, the dynamic and intelligent estimation determines a possibility of the patient avoiding clinical risk, based on the analyte concentration, the rate of change, and other aspects of the dynamic and intelligent estimative algorithms of the preferred embodiments. If there is minimal or no possibility of avoiding the clinical risk, a clinical risk alarm will be triggered. However, if there is a possibility of avoiding the clinical risk, the system can wait a predetermined amount of time and re-analyze the possibility of avoiding the clinical risk. In some embodiments, when there is a possibility of avoiding the clinical risk, the system will further provide targets, therapy recommendations, or other information that can aid the patient in proactively avoiding the clinical risk.

[0240] In some embodiments, a variety of different display methods are used, such as described in the preferred embodiments, which can be toggled through or selectively displayed to the user based on conditions or by selecting a button, for example. As one example, a simple screen can be normally shown that provides an overview of analyte data, for example present analyte value and directional trend. More complex screens can then be selected when a user desires more detailed information, for example, historical analyte data, alarms, clinical risk zones, and the like.

[0241] FIG. 4B is an illustration of the receiver in one embodiment showing an analyte trend graph, including measured analyte values, estimated analyte values, and a clinical risk zone. The receiver 30 includes an LCD screen 34, buttons 7, and a speaker 3 and/or microphone. The screen 34 displays a trend graph in the form of a line representing the historical trend of a patient's analyte concentration. Although axes may or may not be shown on the screen 34, it is understood that a theoretical x-axis represents time and a theoretical y-axis represents analyte concentration.

[0242] In some embodiments such as shown in FIG. 4B, the screen shows thresholds, including a high threshold 200 and a low threshold 202, which represent boundaries between clinically safe and clinically risky conditions for the patients. In one exemplary embodiment, a normal glucose threshold for a glucose sensor is set between about 100 and 160 mg/dL, and the clinical risk zones 204 are illustrated outside of these thresholds. In alternative embodiments, the normal glucose threshold is between about 80 and about 200 mg/dL, between about 55 and about 220 mg/dL, or other threshold that can be set by the manufacturer, physician, patient, computer program, and the like. Although a few

examples of glucose thresholds are given for a glucose sensor, the setting of any analyte threshold is not limited by the preferred embodiments.

[0243] In some embodiments, the screen 34 shows clinical risk zones 204, also referred to as danger zones, through shading, gradients, or other graphical illustrations that indicate areas of increasing clinical risk. Clinical risk zones 204 can be set by a manufacturer, customized by a doctor, and/or set by a user via buttons 7, for example. In some embodiments, the danger zone 204 can be continuously shown on the screen 34, or the danger zone can appear when the measured and/or estimated analyte values fall into the danger zone 204. Additional information can be displayed on the screen, such as an estimated time to clinical risk. In some embodiments, the danger zone can be divided into levels of danger (for example, low, medium, and high) and/or can be color-coded (for example, yellow, orange, and red) or otherwise illustrated to indicate the level of danger to the patient. Additionally, the screen or portion of the screen can dynamically change colors or illustrations that represent a nearness to the clinical risk and/or a severity of clinical risk.

[0244] In some embodiments, such as shown in FIG. 4B, the screen 34 displays a trend graph of measured analyte data 206. Measured analyte data can be smoothed and calibrated such as described in more detail elsewhere herein. Measured analyte data can be displayed for a certain time period (for example, previous 1 hour, 3 hours, 9 hours, etc.) In some embodiments, the user can toggle through screens using buttons 7 to view the measured analyte data for different time periods, using different formats, or to view certain analyte values (for example, highs and lows).

[0245] In some embodiments such as shown in FIG. 4B, the screen 34 displays estimated analyte data 208 using dots. In this illustration, the size of the dots can represent the confidence of the estimation, a variation of estimated values, and the like. For example, as the time gets farther away from the present ( $t=0$ ) the confidence level in the accuracy of the estimation can decline as is appreciated by one skilled in the art. In some alternative embodiments, dashed lines, symbols, icons, and the like can be used to represent the estimated analyte values. In some alternative embodiments, shaded regions, colors, patterns, and the like can also be used to represent the estimated analyte values, a confidence in those values, and/or a variation of those values, such as described in more detail in preferred embodiments.

[0246] Axes, including time and analyte concentration values, can be provided on the screen, however are not required. While not wishing to be bound by theory, it is believed that trend information, thresholds, and danger zones provide sufficient information to represent analyte concentration and clinically educate the user. In some embodiments, time can be represented by symbols, such as a sun and moon to represent day and night. In some embodiments, the present or most recent measured analyte concentration, from the continuous sensor and/or from the reference analyte monitor can be continually, intermittently, or selectively displayed on the screen.

[0247] The estimated analyte values 208 of FIG. 4B include a portion, which extends into the danger zone 204. By providing data in a format that emphasizes the possibility of clinical risk to the patient, appropriate action can be taken by the user (for example, patient, or caretaker) and clinical risk can be preempted.

[0248] FIG. 4C is an illustration of the receiver in another embodiment showing a representation of analyte concentration and directional trend using a gradient bar. In this embodiment, the screen illustrates the measured analyte values and estimated analyte values in a simple but effective manner that communicates valuable analyte information to the user.

[0249] In this embodiment, a gradient bar 210 is provided that includes thresholds 212 set at high and lows such as described in more detail with reference to FIG. 4B, above. Additionally, colors, shading, or other graphical illustration can be present to represent danger zones 214 on the gradient bar 210 such as described in more detail with reference to FIG. 4B, above.

[0250] The measured analyte value is represented on the gradient bar 210 by a marker 216, such as a darkened or colored bar. By representing the measured analyte value with a bar 216, a low-resolution analyte value is presented to the user (for example, within a range of values). For example, each segment on the gradient bar 210 can represent about 10 mg/dL of glucose concentration. As another example, each segment can dynamically represent the range of values that fall within the "A" and "B" regions of the Clarke Error Grid. While not wishing to be bound by theory, it is believed that inaccuracies known both in reference analyte monitors and/or continuous analyte sensors are likely due to known variables such as described in more detail elsewhere herein, and can be de-emphasized such that a user focuses on proactive care of the condition, rather than inconsequential discrepancies within and between reference analyte monitors and continuous analyte sensors.

[0251] Additionally, the representative gradient bar communicates the directional trend of the analyte concentration to the user in a simple and effective manner, namely by a directional arrow 218. For example, in conventional diabetic blood glucose monitoring, a person with diabetes obtains a blood sample and measures the glucose concentration using a test strip, and the like. Unfortunately, this information does not tell the person with diabetes whether the blood glucose concentration is rising or falling. Rising or falling directional trend information can be particularly important in a situation such as illustrated in FIG. 4C, wherein if the user does not know that the glucose concentration is rising, he/she may assume that the glucose concentration is falling and not attend to his/her condition. However, because rising directional trend information 218 is provided, the person with diabetes can preempt the clinical risk by attending to his/her condition (for example, administer insulin). Estimated analyte data can be incorporated into the directional trend information by characteristics of the arrow, for example, size, color, flash speed, and the like.

[0252] In some embodiments, the gradient bar can be a vertical instead of horizontal bar. In some embodiments, a gradient fill can be used to represent analyte concentration, variation, or clinical risk, for example. In some embodiments, the bar graph includes color, for example the center can be green in the safe zone that graduates to red in the danger zones; this can be in addition to or in place of the divided segments. In some embodiments, the segments of the bar graph are clearly divided by lines; however color, gradation, and the like can be used to represent areas of the bar graph. In some embodiments, the directional arrow can



be represented by a cascading level of arrows to represent slow or rapid rate of change. In some embodiments, the directional arrow can be flashing to represent movement or pending danger.

[0253] The screen 34 of FIG. 4C can further comprise a numerical representation of analyte concentration, date, time, or other information to be communicated to the patient. However, a user can advantageously extrapolate information helpful for his/her condition using the simple and effective representation of this embodiment shown in FIG. 4C, without reading a numeric representation of his/her analyte concentration.

[0254] In some alternative embodiments, a trend graph or gradient bar, a dial, pie chart, or other visual representation can provide analyte data using shading, colors, patterns, icons, animation, and the like.

[0255] FIG. 4D is an illustration of a receiver 30 in another embodiment, including a screen 34 that shows a numerical representation of the most recent measured analyte value 252. This numerical value 252 is preferably a calibrated analyte value, such as described in more detail with reference to FIGS. 5 and 6. Additionally, this embodiment preferably provides an arrow 254 on the screen 34, which represents the rate of change of the host's analyte concentration. A bold "up" arrow is shown on the drawing, which preferably represents a relatively quickly increasing rate of change. The arrows shown with dotted lines illustrate examples of other directional arrows (for example, rotated by 45 degrees), which can be useful on the screen to represent various other positive and negative rates of change. Although the directional arrows shown have a relative low resolution (45 degrees of accuracy), other arrows can be rotated with a high resolution of accuracy (for example one degree of accuracy) to more accurately represent the rate of change of the host's analyte concentration. In some alternative embodiments, the screen provides an indication of the acceleration of the host's analyte concentration.

[0256] A second numerical value 256 is shown, which is representative of a variation of the measured analyte value 252. The second numerical value is preferably determined from a variation analysis based on statistical, clinical, or physiological parameters, such as described in more detail elsewhere herein. In one embodiment, the second numerical value 256 is determined based on clinical risk (for example, weighted for the greatest possible clinical risk to a patient). In another embodiment, the second numerical representation 256 is an estimated analyte value extrapolated to compensate for a time lag, such as described in more detail elsewhere herein. In some alternative embodiments, the receiver displays a range of numerical analyte values that best represents the host's estimated analyte value (for example, +/-10%). In some embodiments, the range is weighted based on clinical risk to the patient. In some embodiments, the range is representative of a confidence in the estimated analyte value and/or a variation of those values. In some embodiments, the range is adjustable.

[0257] Referring again to FIG. 4A, communication ports, including a PC communication (com) port 48 and a reference glucose monitor com port 49 can be provided to enable communication with systems that are separate from, or integral with, the receiver 30. The PC com port 48, for

example, a serial communications port, allows for communicating with another computer system (e.g., PC, PDA, server, and the like). In one exemplary embodiment, the receiver 30 is able to download historical data to a physician's PC for retrospective analysis by the physician. The reference glucose monitor com port 49 allows for communicating with a reference glucose monitor (not shown) so that reference glucose values can be downloaded into the receiver 30, for example, automatically. In one embodiment, the reference glucose monitor is integral with the receiver 30, and the reference glucose com port 49 allows internal communication between the two integral systems. In another embodiment, the reference glucose monitor com port 49 allows a wireless or wired connection to reference glucose monitor such as a self-monitoring blood glucose monitor (e.g., for measuring finger stick blood samples).

#### Calibration

[0258] Reference is now made to FIG. 5, which is a flow chart 50 that illustrates the process of initial calibration and data output of the glucose sensor (e.g., 10 or 100) in one embodiment.

[0259] Calibration of the glucose sensor comprises data processing that converts a sensor data stream into an estimated glucose measurement that is meaningful to a user. Accordingly, a reference glucose value can be used to calibrate the data stream from the glucose sensor. In one embodiment, the analyte sensor is a continuous glucose sensor and one or more reference glucose values are used to calibrate the data stream from the sensor. The calibration can be performed on a real-time basis and/or retrospectively recalibrated. However in alternative embodiments, other calibration techniques can be utilized, for example using another constant analyte (for example, folic acid, ascorbate, urate, and the like) as a baseline, factory calibration, periodic clinical calibration, oxygen calibration (for example, using a plurality of sensor heads), and the like can be used.

[0260] At block 51, a sensor data receiving module, also referred to as the sensor data module, or processor module, receives sensor data (e.g., a data stream), including one or more time-spaced sensor data points hereinafter referred to as "data stream," "sensor data," "sensor analyte data", "glucose signal," from a sensor via the receiver, which can be in wired or wireless communication with the sensor. The sensor data can be raw or smoothed (filtered), or include both raw and smoothed data. In some embodiments, raw sensor data may include an integrated digital data value, e.g., a value averaged over a time period such as by a charge capacitor. Smoothed sensor data point(s) can be filtered in certain embodiments using a filter, for example, a finite impulse response (FIR) or infinite impulse response (IIR) filter. Some or all of the sensor data point(s) can be replaced by estimated signal values to address signal noise such as described in more detail elsewhere herein. It is noted that during the initialization of the sensor, prior to initial calibration, the receiver 30 (e.g., computer system) receives and stores the sensor data, however it may not display any data to the user until initial calibration and eventually stabilization of the sensor has been determined.

[0261] At block 52, a reference data receiving module, also referred to as the reference input module, or the processor module, receives reference data from a reference glucose monitor, including one or more reference data

points. In one embodiment, the reference glucose points can comprise results from a self-monitored blood glucose test (e.g., from a finger stick test). In one such embodiment, the user can administer a self-monitored blood glucose test to obtain a glucose value (e.g., point) using any known glucose sensor, and enter the numeric glucose value into the computer system. In another such embodiment, a self-monitored blood glucose test comprises a wired or wireless connection to the receiver 30 (e.g. computer system) so that the user simply initiates a connection between the two devices, and the reference glucose data is passed or downloaded between the self-monitored blood glucose test and the receiver 30. In yet another such embodiment, the self-monitored glucose test is integral with the receiver 30 so that the user simply provides a blood sample to the receiver 30, and the receiver 30 runs the glucose test to determine a reference glucose value.

[0262] In some embodiments, the calibration process 50 monitors the continuous analyte sensor data stream to determine a preferred time for capturing reference analyte concentration values for calibration of the continuous sensor data stream. In an example wherein the analyte sensor is a continuous glucose sensor, when data (for example, observed from the data stream) changes too rapidly, the reference glucose value may not be sufficiently reliable for calibration due to unstable glucose changes in the host. In contrast, when sensor glucose data are relatively stable (for example, relatively low rate of change), a reference glucose value can be taken for a reliable calibration. In one embodiment, the calibration process 38 can prompt the user via the user interface to “calibrate now” when the analyte sensor is considered stable.

[0263] In some embodiments, the calibration process 50 can prompt the user via the user interface 47 to obtain a reference analyte value for calibration at intervals, for example when analyte concentrations are at high and/or low values. In some additional embodiments, the user interface 47 can prompt the user to obtain a reference analyte value for calibration based upon certain events, such as meals, exercise, large excursions in analyte levels, faulty or interrupted data readings, and the like. In some embodiments, the estimative algorithms can provide information useful in determining when to request a reference analyte value. For example, when estimated analyte values indicate approaching clinical risk, the user interface 47 can prompt the user to obtain a reference analyte value.

[0264] Certain acceptability parameters can be set for reference values received from the user. For example, in one embodiment, the receiver may only accept reference glucose values between about 40 and about 400 mg/dL.

[0265] In some embodiments, the calibration process 50 performs outlier detection on the reference data and time corresponding sensor data. Outlier detection compares a reference analyte value with a time corresponding measured analyte value to ensure a predetermined statistically, physiologically, or clinically acceptable correlation between the corresponding data exists. In an example wherein the analyte sensor is a glucose sensor, the reference glucose data is matched with substantially time corresponding calibrated sensor data and the matched data are plotted on a Clarke Error Grid to determine whether the reference analyte value is an outlier based on clinical acceptability, such as

described in more detail with reference U.S. Publication No. US-2005-0027463-A1. In some embodiments, outlier detection compares a reference analyte value with a corresponding estimated analyte value, such as described in more detail elsewhere herein and with reference to the above-described patent application, and the matched data is evaluated using statistical, clinical, and/or physiological parameters to determine the acceptability of the matched data pair. In alternative embodiments, outlier detection can be determined by other clinical, statistical, and/or physiological boundaries.

[0266] In some embodiments, outlier detection utilizes signal artifacts detection, described in more detail elsewhere herein, to determine the reliability of the reference data and/or sensor data responsive to the results of the signal artifacts detection. For example, if a certain level of signal artifacts is not detected in the data signal, then the sensor data is determined to be reliable. As another example, if a certain level of signal artifacts are detected in the data signal, then the reliability of the reference glucose data if the signal artifact is determined.

[0267] At block 53, a data matching module, also referred to as the processor module, matches reference data (e.g., one or more reference glucose data points) with substantially time corresponding sensor data (e.g., one or more sensor data points) to provide one or more matched data pairs. In one embodiment, one reference data point is matched to one time corresponding sensor data point to form a matched data pair. In another embodiment, a plurality of reference data points are averaged (e.g., equally or non-equally weighted average, mean-value, median, and the like) and matched to one time corresponding sensor data point to form a matched data pair. In another embodiment, one reference data point is matched to a plurality of time corresponding sensor data points averaged to form a matched data pair. In yet another embodiment, a plurality of reference data points are averaged and matched to a plurality of time corresponding sensor data points averaged to form a matched data pair.

[0268] In one embodiment, a time corresponding sensor data comprises one or more sensor data points that occur, for example,  $15 \pm 5$  min after the reference glucose data timestamp (e.g., the time that the reference glucose data is obtained). In this embodiment, the 15 minute time delay has been chosen to account for an approximately 10 minute delay introduced by the filter used in data smoothing and an approximately 5 minute diffusional time-lag (e.g., the time necessary for the glucose to diffusion through a membrane(s) of a glucose sensor). In alternative embodiments, the time corresponding sensor value can be more or less than in the above-described embodiment, for example  $\pm 60$  minutes. Variability in time correspondence of sensor and reference data can be attributed to, for example, a longer or shorter time delay introduced during signal estimation, or if the configuration of the glucose sensor incurs a greater or lesser physiological time lag.

[0269] In some practical implementations of the sensor, the reference glucose data can be obtained at a time that is different from the time that the data is input into the receiver 30. Accordingly, it should be noted that the “time stamp” of the reference glucose (e.g., the time at which the reference glucose value was obtained) may not be the same as the time at which the receiver 30 obtained the reference glucose data. Therefore, some embodiments include a time stamp require-

ment that ensures that the receiver **30** stores the accurate time stamp for each reference glucose value, that is, the time at which the reference value was actually obtained from the user.

[0270] In some embodiments, tests are used to evaluate the best-matched pair using a reference data point against individual sensor values over a predetermined time period (e.g., about 30 minutes). In one such embodiment, the reference data point is matched with sensor data points at 5-minute intervals and each matched pair is evaluated. The matched pair with the best correlation can be selected as the matched pair for data processing. In some alternative embodiments, matching a reference data point with an average of a plurality of sensor data points over a predetermined time period can be used to form a matched pair.

[0271] In some embodiments wherein the data signal is evaluated for signal artifacts, as described in more detail elsewhere herein, the processor module is configured to form a matching data pair only if a signal artifact is not detected. In some embodiments wherein the data signal is evaluated for signal artifacts, the processor module is configured to prompt a user for a reference glucose value during a time when one or more signal artifact(s) is not detected.

[0272] At block **54**, a calibration set module, also referred to as the processor module, forms an initial calibration set from a set of one or more matched data pairs, which are used to determine the relationship between the reference glucose data and the sensor glucose data, such as described in more detail with reference to block **55**, below.

[0273] The matched data pairs, which make up the initial calibration set, can be selected according to predetermined criteria. In some embodiments, the number (n) of data pair(s) selected for the initial calibration set is one. In other embodiments, n data pairs are selected for the initial calibration set wherein n is a function of the frequency of the received reference data points. In one exemplary embodiment, six data pairs make up the initial calibration set. In another embodiment, the calibration set includes only one data pair.

[0274] In some embodiments, the data pairs are selected only within a certain glucose value threshold, for example wherein the reference glucose value is between about 40 and about 400 mg/dL. In some embodiments, the data pairs that form the initial calibration set are selected according to their time stamp. In certain embodiments, the data pairs that form the initial calibration set are selected according to their time stamp, for example, by waiting a predetermined “break-in” time period after implantation, the stability of the sensor data can be increased. In certain embodiments, the data pairs that form the initial calibration set are spread out over a predetermined time period, for example, a period of two hours or more. In certain embodiments, the data pairs that form the initial calibration set are spread out over a predetermined glucose range, for example, spread out over a range of at least 90 mg/dL or more.

[0275] In some embodiments, wherein the data signal is evaluated for signal artifacts, as described in more detail elsewhere herein, the processor module is configured to utilize the reference data for calibration of the glucose sensor only if a signal artifact is not detected.

[0276] At block **55**, the conversion function module, also referred to as the processor module, uses the calibration set

to create a conversion function. The conversion function substantially defines the relationship between the reference glucose data and the glucose sensor data. A variety of known methods can be used with the preferred embodiments to create the conversion function from the calibration set. In one embodiment, wherein a plurality of matched data points form the initial calibration set, a linear least squares regression is performed on the initial calibration set such as described in more detail with reference to FIG. 6.

[0277] At block **56**, a sensor data transformation module, also referred to as the processor module, uses the conversion function to transform sensor data into substantially real-time glucose value estimates, also referred to as calibrated data, or converted sensor data, as sensor data is continuously (or intermittently) received from the sensor. For example, the sensor data, which can be provided to the receiver in “counts,” is translated in to estimate analyte value(s) in mg/dL. In other words, the offset value at any given point in time can be subtracted from the raw value (e.g., in counts) and divided by the slope to obtain the estimated glucose value:

$$\text{mg/dL} = \frac{(\text{rawvalue} - \text{offset})}{\text{slope}}$$

[0278] In some alternative embodiments, the sensor and/or reference glucose values are stored in a database for retrospective analysis.

[0279] At block **57**, an output module, also referred to as the processor module, provides output to the user via the user interface. The output is representative of the estimated glucose value, which is determined by converting the sensor data into a meaningful glucose value such as described in more detail with reference to block **56**, above. User output can be in the form of a numeric estimated glucose value, an indication of directional trend of glucose concentration, and/or a graphical representation of the estimated glucose data over a period of time, for example. Other representations of the estimated glucose values are also possible, for example audio and tactile.

[0280] In one embodiment, such as shown in FIG. 3A, the estimated glucose value is represented by a numeric value. In other exemplary embodiments, such as shown in FIGS. 3B to 3D, the user interface graphically represents the estimated glucose data trend over predetermined a time period (e.g., one, three, and nine hours, respectively). In alternative embodiments, other time periods can be represented. In alternative embodiments, other time periods can be represented. In alternative embodiments, pictures, animation, charts, graphs, ranges of values, and numeric data can be selectively displayed.

[0281] Accordingly, after initial calibration of the sensor, real-time continuous glucose information can be displayed on the user interface so that the user can regularly and proactively care for his/her diabetic condition within the bounds set by his/her physician.

[0282] In alternative embodiments, the conversion function is used to predict glucose values at future points in time. These predicted values can be used to alert the user of upcoming hypoglycemic or hyperglycemic events. Addi-

tionally, predicted values can be used to compensate for a time lag (e.g., 15 minute time lag such as described elsewhere herein), if any, so that an estimated glucose value displayed to the user represents the instant time, rather than a time delayed estimated value.

[0283] In some embodiments, the substantially real-time estimated glucose value, a predicted future estimated glucose value, a rate of change, and/or a directional trend of the glucose concentration is used to control the administration of a constituent to the user, including an appropriate amount and time, in order to control an aspect of the user's biological system. One such example is a closed loop glucose sensor and insulin pump, wherein the glucose data (e.g., estimated glucose value, rate of change, and/or directional trend) from the glucose sensor is used to determine the amount of insulin, and time of administration, that can be given to a diabetic user to evade hyper- and hypoglycemic conditions.

[0284] FIG. 6 is a graph that illustrates one embodiment of a regression performed on a calibration set to create a conversion function such as described with reference to FIG. 5, block 55, above. In this embodiment, a linear least squares regression is performed on the initial calibration set. The x-axis represents reference glucose data; the y-axis represents sensor data. The graph pictorially illustrates regression of matched pairs 66 in the calibration set. The regression calculates a slope 62 and an offset 64, for example, using the well-known slope-intercept equation ( $y=mx+b$ ), which defines the conversion function.

[0285] In alternative embodiments, other algorithms could be used to determine the conversion function, for example forms of linear and non-linear regression, for example fuzzy logic, neural networks, piece-wise linear regression, polynomial fit, genetic algorithms, and other pattern recognition and signal estimation techniques.

[0286] In yet other alternative embodiments, the conversion function can comprise two or more different optimal conversions because an optimal conversion at any time is dependent on one or more parameters, such as time of day, calories consumed, exercise, or glucose concentration above or below a set threshold, for example. In one such exemplary embodiment, the conversion function is adapted for the estimated glucose concentration (e.g., high vs. low). For example in an implantable glucose sensor it has been observed that the cells surrounding the implant will consume at least a small amount of glucose as it diffuses toward the glucose sensor. Assuming the cells consume substantially the same amount of glucose whether the glucose concentration is low or high, this phenomenon will have a greater effect on the concentration of glucose during low blood sugar episodes than the effect on the concentration of glucose during relatively higher blood sugar episodes. Accordingly, the conversion function can be adapted to compensate for the sensitivity differences in blood sugar level. In one implementation, the conversion function comprises two different regression lines, wherein a first regression line is applied when the estimated blood glucose concentration is at or below a certain threshold (e.g., 150 mg/dL) and a second regression line is applied when the estimated blood glucose concentration is at or above a certain threshold (e.g., 150 mg/dL). In one alternative implementation, a predetermined pivot of the regression line that

forms the conversion function can be applied when the estimated blood is above or below a set threshold (e.g., 150 mg/dL), wherein the pivot and threshold are determined from a retrospective analysis of the performance of a conversion function and its performance at a range of glucose concentrations. In another implementation, the regression line that forms the conversion function is pivoted about a point in order to comply with clinical acceptability standards (e.g., Clarke Error Grid, Consensus Grid, mean absolute relative difference, or other clinical cost function). Although only a few example implementations are described, other embodiments include numerous implementations wherein the conversion function is adaptively applied based on one or more parameters that can affect the sensitivity of the sensor data over time.

[0287] Additional methods for processing sensor glucose data are disclosed in U.S. Publication No. US-2005-0027463-A1. In view of the above-described data processing, it should be obvious that improving the accuracy of the data stream will be advantageous for improving output of glucose sensor data. Accordingly, the following description is related to improving data output by decreasing signal artifacts on the raw data stream from the sensor. The data smoothing methods of preferred embodiments can be employed in conjunction with any sensor or monitor measuring levels of an analyte in vivo, wherein the level of the analyte fluctuates over time, including but not limited to such sensors as described in U.S. Pat. No. 6,001,067 to Shults et al.; U.S. Patent Application 2003/0023317 to Brauker et al.; U.S. Pat. No. 6,212,416 to Ward et al.; U.S. Pat. No. 6,119,028 to Schulman et al.; U.S. Pat. No. 6,400,974 to Lesho; U.S. Pat. No. 6,595,919 to Berner et al.; U.S. Pat. No. 6,141,573 to Kurnik et al.; U.S. Pat. No. 6,122,536 to Sun et al.; European Patent Application EP 1153571 to Varall et al.; U.S. Pat. No. 6,512,939 to Colvin et al.; U.S. Pat. No. 5,605,152 to Slate et al.; U.S. Pat. No. 4,431,004 to Bessman et al.; U.S. Pat. No. 4,703,756 to Gough et al.; U.S. Pat. No. 6,514,718 to Heller et al; and U.S. Pat. No. 5,985,129 to Gough et al.

#### Signal Artifacts

[0288] Typically, a glucose sensor produces a data stream that is indicative of the glucose concentration of a host, such as described in more detail above. However, it is well known that the above described glucose sensors includes only a few examples of an abundance of glucose sensors that are able to provide raw data output indicative of the concentration of glucose. Thus, it should be understood that the systems and methods described herein, including signal artifacts detection, signal artifacts replacement, and other data processing, can be applied to a data stream obtained from any glucose sensor.

[0289] Raw data streams typically have some amount of "system noise," caused by unwanted electronic or diffusion-related noise that degrades the quality of the signal and thus the data. Accordingly, conventional glucose sensors are known to smooth raw data using methods that filter out this system noise, and the like, in order to improve the signal to noise ratio, and thus data output. One example of a conventional data-smoothing algorithm includes a finite impulse response filter (FIR), which is particularly suited for reducing high-frequency noise (see Steil et al. U.S. Pat. No. 6,558,351).

[0290] FIGS. 7A and 7B are graphs of raw data streams from an implantable glucose sensor prior to data smoothing. FIG. 7A is a graph that shows a raw data stream obtained from a glucose sensor over an approximately 4 hour time span in one example. FIG. 7B is a graph that shows a raw data stream obtained from a glucose sensor over an approximately 36 hour time span in another example. The x-axis represents time in minutes. The y-axis represents sensor data in counts. In these examples, sensor output in counts is transmitted every 30-seconds.

[0291] The “system noise” such as shown in sections 72a, 72b of the data streams of FIGS. 7A and 7B, respectively, illustrate time periods during which system noise can be seen on the data stream. This system noise can be characterized as Gaussian, Brownian, and/or linear noise, and can be substantially normally distributed about the mean. The system noise is likely electronic and diffusion-related, and the like, and can be smoothed using techniques such as by using an FIR filter. As another example, the raw data can be represented by an integrated value, for example, by integrating the signal over a time period (e.g., 30 seconds or 5 minutes), and providing an averaged (e.g., integrated) data point there from. The system noise such as shown in the data of sections 72a, 72b is a fairly accurate representation of glucose concentration and can be confidently used to report glucose concentration to the user when appropriately calibrated.

[0292] The “signal artifacts” such as shown in sections 74a, 74b of the data stream of FIGS. 7A and 7B, respectively, illustrate time periods during which “signal artifacts” can be seen, which are significantly different from the previously described system noise (sections 72a, 72b). This noise, such as shown in section 74a and 74b, is referred to herein as “signal artifacts” and may be described as “transient non-glucose dependent signal artifacts that have a higher amplitude than system noise.” At times, signal artifacts comprise low noise, which generally refers to noise that substantially decreases signal amplitude 76a, 76b herein, which is best seen in the signal artifacts 74b of FIG. 7B. Occasional high spikes 78a, 78b, which generally correspond to noise that substantially increases signal amplitude, can also be seen in the signal artifacts, which generally occur after a period of low noise. These high spikes are generally observed after transient low noise and typically result after reaction rate-limiting phenomena occur. For example, in an embodiment where a glucose sensor requires an enzymatic reaction, local ischemia creates a reaction that is rate-limited by oxygen, which is responsible for low noise. In this situation, glucose would be expected to build up in the membrane because it would not be completely catabolized during the oxygen deficit. When oxygen is again in excess, there would also be excess glucose due to the transient oxygen deficit. The enzyme rate would speed up for a short period until the excess glucose is catabolized, resulting in high noise. Additionally, noise can be distributed both above and below the expected signal.

[0293] Analysis of signal artifacts such as shown sections 74a, 74b of FIGS. 7A and 7B, respectively, indicates that the observed low noise is caused by substantially non-glucose reaction dependent phenomena, such as ischemia that occurs within or around a glucose sensor in vivo, for example, which results in the reaction becoming oxygen dependent. As a first example, at high glucose levels, oxygen can

become limiting to the enzymatic reaction, resulting in a non-glucose dependent downward trend in the data (best seen in FIG. 7B). As a second example, certain movements or postures taken by the patient can cause transient downward noise as blood is squeezed out of the capillaries resulting in local ischemia, and causing non-glucose dependent low noise. Because excess oxygen (relative to glucose) is necessary for proper sensor function, transient ischemia can result in a loss of signal gain in the sensor data. In this second example oxygen can also become transiently limited due to contracture of tissues around the sensor interface. This is similar to the blanching of skin that can be observed when one puts pressure on it. Under such pressure, transient ischemia can occur in both the epidermis and subcutaneous tissue. Transient ischemia is common and well tolerated by subcutaneous tissue.

[0294] In another example of non-glucose reaction rate-limiting phenomena, skin temperature can vary dramatically, which can result in thermally related erosion of the signal (e.g., temperature changes between 32 and 39 degrees Celsius have been measured in humans). In yet another embodiment, wherein the glucose sensor is placed intravenously, increased impedance can result from the sensor resting against wall of the blood vessel, for example, producing this non-glucose reaction rate-limiting noise due to oxygen deficiency.

[0295] Because signal artifacts are not mere system noise, but rather are caused by known or unknown non-glucose related mechanisms, methods used for conventional random noise filtration produce data lower (or in some cases higher) than the actual blood glucose levels due to the expansive nature of these signal artifacts. To overcome this, the preferred embodiments provide systems and methods for replacing at least some of the signal artifacts by estimating glucose signal values.

[0296] FIG. 8 is a flow chart that illustrates the process of detecting and replacing signal artifacts in certain embodiments. It is noted that “signal artifacts” particularly refers to the transient non-glucose related artifacts such as described in more detail elsewhere herein. Typically, signal artifacts are caused by non-glucose rate-limiting phenomenon such as described in more detail above.

[0297] At block 82, a sensor data receiving module, also referred to as the sensor data module 82, or processor module, receives sensor data (e.g., a data stream), including one or more time-spaced sensor data points. In some embodiments, the data stream is stored in the sensor for additional processing; in some alternative embodiments, the sensor periodically transmits the data stream to the receiver 30, which can be in wired or wireless communication with the sensor. In some embodiments, raw and/or filtered data is stored in the sensor and/or receiver.

[0298] At block 84, a signal artifacts detection module, also referred to as the signal artifacts detector 84 or signal reliability module, is programmed to detect transient non-glucose related signal artifacts in the data stream, such as described in more detail with reference to FIGS. 7A and 7B, above. The signal artifacts detector can comprise an oxygen detector, a pH detector, a temperature detector, and/or a pressure/stress detector, for example, the signal artifacts detector 29 in FIG. 2. In some embodiments, the signal artifacts detector at block 84 is located within the processor

22 in FIG. 2 and utilizes existing components of the glucose sensor to detect signal artifacts, for example by pulsed amperometric detection, counter electrode monitoring, reference electrode monitoring, and frequency content monitoring, which are described elsewhere herein. In yet other embodiments, the data stream can be sent from the sensor to the receiver which comprises programming in the processor 42 in FIG. 4 that performs algorithms to detect signal artifacts, for example such as described with reference to "Cone of Possibility Detection" method and/or by comparing raw data vs. filtered data, both of which are described in more detail below. Numerous embodiments for detecting signal artifacts are described in more detail in the section entitled, "Signal Artifacts Detection," all of which are encompassed by the signal artifacts detection at block 84.

[0299] In certain embodiments, the processor module in either the sensor electronics and/or the receiver electronics can evaluate an intermittent or continuous signal-to-noise measurement to determine aberrancy of sensor data responsive to a signal-to-noise ratio above a set threshold. In certain embodiments, signal residuals (e.g., by comparing raw and filtered data) can be intermittently or continuously analyzed for noise above a set threshold. In certain embodiments, pattern recognition can be used to identify noise associated with physiological conditions, such as low oxygen, or other known signal aberrancies. Accordingly, in these embodiments, the system can be configured, in response to aberrancies in the data stream, to trigger signal estimation, adaptively filter the data stream according to the aberrancy, and the like, as described in more detail elsewhere herein.

[0300] At block 86, the signal artifacts replacement module, also referred to as the signal estimation module, replaces some or an entire data stream with estimated glucose signal values using signal estimation. Numerous embodiments for performing signal estimation are described in more detail in the section entitled "Signal Artifacts Replacement," all of which are encompassed by the signal artifacts replacement module, block 86. It is noted that in some embodiments, signal estimation/replacement is initiated in response to positive detection of signal artifacts on the data stream, and subsequently stopped in response to detection of negligible signal artifacts on the data stream. In some embodiments, the system waits a predetermined time period (e.g., between 30 seconds and 30 minutes) before switching the signal estimation on or off to ensure that a consistent detection has been ascertained. In some embodiments, however, signal estimation/replacement can continuously or continually run.

[0301] Some embodiments of signal estimation can additionally include discarding data that is considered sufficiently unreliable and/or erroneous such that the data should not be used in a signal estimation algorithm. In these embodiments, the system can be programmed to discard outlier data points, for example data points that are so extreme that they can skew the data even with the most comprehensive filtering or signal estimation, and optionally replace those points with a projected value based on historical data or present data (e.g., linear regression, recursive filtering, and the like). One example of discarding sensor data includes discarding sensor data that falls outside of a "Cone of Possibility" such as described in more detail elsewhere herein. Another example includes discarding sensor data when signal artifacts detection detects values out-

side of a predetermined threshold (e.g., oxygen concentration below a set threshold, temperature above a certain threshold, signal amplitude above a certain threshold, etc). Any of the signal estimation/replacement algorithms described herein can then be used to project data values for those data that were discarded.

#### Signal Artifacts Detection

[0302] Analysis of signals from glucose sensors indicates at least two types of noise, which are characterized herein as 1) system noise and 2) signal artifacts, such as described in more detail above. It is noted that system noise is easily smoothed using the algorithms provided herein; however, the systems and methods described herein particularly address signal artifacts, by replacing transient erroneous signal noise caused by rate-limiting phenomenon (e.g., non-glucose related signal) with estimated signal values, for example.

[0303] In certain embodiments of signal artifacts detection, oxygen monitoring is used to detect whether transient non-glucose dependent signal artifacts due to ischemia. Low oxygen concentrations in or near the glucose sensor can account for a large part of the transient non-glucose related signal artifacts as defined herein on a glucose sensor signal, particularly in subcutaneously implantable glucose sensors. Accordingly, detecting oxygen concentration, and determining if ischemia exists can discover ischemia-related signal artifacts. A variety of methods can be used to test for oxygen. For example, an oxygen-sensing electrode, or other oxygen sensor can be employed. The measurement of oxygen concentration can be sent to a processor, which determines if the oxygen concentration indicates ischemia.

[0304] In some embodiments of ischemia detection, an oxygen sensor is placed proximal to or within the glucose sensor. For example, the oxygen sensor can be located on or near the glucose sensor such that their respective local environments are shared and oxygen concentration measurement from the oxygen sensor represents an accurate measurement of the oxygen concentration on or within the glucose sensor. In some alternative embodiments of ischemia detection, an oxygen sensor is also placed distal to the glucose sensor. For example, the oxygen sensor can be located sufficiently far from the glucose sensor such that their respective local environments are not shared and oxygen measurements from the proximal and distal oxygen sensors can be compared to determine the relative difference between the respective local environments. By comparing oxygen concentration at proximal and distal oxygen sensors, change in local (proximal) oxygen concentration can be determined from a reference (distal) oxygen concentration.

[0305] Oxygen sensors are useful for a variety of purposes. For example, U.S. Pat. No. 6,512,939 to Colvin et al., which is incorporated herein by reference, discloses an oxygen sensor that measures background oxygen levels. However, Colvin et al. rely on the oxygen sensor for the data stream of glucose measurements by subtraction of oxygen remaining after exhaustion of glucose by an enzymatic reaction from total unreacted oxygen concentration.

[0306] In another embodiment of ischemia detection, wherein the glucose sensor is an electrochemical sensor that includes a potentiostat, pulsed amperometric detection can be employed to determine an oxygen measurement. Pulsed

amperometric detection includes switching, cycling, or pulsing the voltage of the working electrode (or reference electrode) in an electrochemical system, for example between a positive voltage (e.g., +0.6 for detecting glucose) and a negative voltage (e.g., -0.6 for detecting oxygen). U.S. Pat. No. 4,680,268 to Clark, Jr., which is incorporated by reference herein, describes pulsed amperometric detection. In contrast to using signal replacement, Clark, Jr. addresses oxygen deficiency by supplying additional oxygen to the enzymatic reaction.

[0307] In another embodiment of ischemia detection, wherein the glucose sensor is an electrochemical sensor and contains a potentiostat, oxygen deficiency can be seen at the counter electrode when insufficient oxygen is available for reduction, which thereby affects the counter electrode in that it is unable to balance the current coming from the working electrode. When insufficient oxygen is available for the counter electrode, the counter electrode can be driven in its electrochemical search for electrons all the way to its most negative value, which could be ground or 0.0V, which causes the reference to shift, reducing the bias voltage such as described in more detail below. In other words, a common result of ischemia will be seen as a drop off in sensor current as a function of glucose concentration (e.g., lower sensitivity). This happens because the working electrode no longer oxidizes all of the  $H_2O_2$  arriving at its surface because of the reduced bias. In some extreme circumstances, an increase in glucose can produce no increase in current or even a decrease in current.

[0308] FIG. 9 is a graph that shows a comparison of sensor current and counter-electrode voltage in a host over time. The x-axis represents time in minutes. The first y-axis 91 represents sensor counts from the working electrode and thus plots a raw sensor data stream 92 for the glucose sensor over a period of time. The second y-axis 93 represents counter-electrode voltage 94 in counts. The graph illustrates the correlation between sensor data 92 and counter-electrode voltage 94; particularly, that erroneous counter electrode function 96 where the counter voltages drops approximately to zero substantially coincides with transient non-glucose related signal artifacts 98. In other words, when counter-electrode voltage is at or near zero, sensor data includes signal artifacts.

[0309] In another embodiment of ischemia detection, wherein the glucose sensor is an electrochemical sensor and contains a two- or three-cell electrochemical cell, signal artifacts are detected by monitoring the reference electrode. This "reference drift detection" embodiment takes advantage of the fact that the reference electrode will vary or drift in order to maintain a stable bias potential with the working electrode, such as described in more detail herein. This "drifting" generally indicates non-glucose reaction rate-limiting noise, for example due to ischemia. It is noted that the following example describes an embodiment wherein the sensor includes a working, reference, and counter electrodes, such as described in more detail elsewhere herein; however the principles of this embodiment are applicable to a two-cell (e.g., anode and cathode) electrochemical cell as is understood in the art.

[0310] FIG. 10A is a circuit diagram of a potentiostat that controls a typical three-electrode system, which can be employed with a glucose sensor such as described with

reference to FIGS. 1 and 2. The potentiostat includes a working electrode 100, a reference electrode 102, and a counter electrode 104. The voltage applied to the working electrode is a constant value (e.g., +1.2V) and the voltage applied to the reference electrode is also set at a constant value (e.g., +0.6V) such that the potential ( $V_{BIAS}$ ) applied between the working and reference electrodes is maintained at a constant value (e.g., +0.6V). The counter electrode is configured to have a constant current (equal to the current being measured by the working electrode), which is accomplished by varying the voltage at the counter electrode in order to balance the current going through the working electrode 100 such that current does not pass through the reference electrode 102. A negative feedback loop 107 is constructed from an operational amplifier (OP AMP), the reference electrode 102, the counter electrode 104, and a reference potential, to maintain the reference electrode at a constant voltage.

[0311] In practice, a glucose sensor of one embodiment comprises a membrane that contains glucose oxidase that catalyzes the conversion of oxygen and glucose to hydrogen peroxide and gluconate, such as described with reference to FIGS. 1 and 2. Therefore, for each glucose molecule metabolized there is a change equivalent in molecular concentration in the co-reactant  $O_2$  and the product  $H_2O_2$ . Consequently, one can use an electrode (e.g., working electrode 100) to monitor the concentration-induced current change in either the co-reactant or the product to determine glucose concentration.

[0312] One limitation of the electrochemistry is seen when insufficient negative voltage is available to the counter electrode 104 to balance the working electrode 100. This limitation can occur when insufficient oxygen is available to the counter electrode 104 for reduction, for example. When this limitation occurs, the counter electrode can no longer vary its voltage to maintain a balanced current with the working electrode and thus the negative feedback loop 107 used to maintain the reference electrode is compromised. Consequently, the reference electrode voltage will change or "drift," altering the applied bias potential (i.e., the potential applied between the working and reference electrodes), thereby decreasing the applied bias potential. When this change in applied bias potential occurs, the working electrode can produce erroneous glucose measurements due to either increased or decreased signal strength ( $I_{SENSE}$ ).

[0313] FIG. 10B a diagram referred to as Cyclic-Voltammetry (CV) curve, wherein the x-axis represents the applied potential ( $V_{BIAS}$ ) and the y-axis represents the signal strength of the working electrode ( $I_{SENSE}$ ). A curve 108 illustrates an expected CV curve when the potentiostat is functioning normally. Typically, desired bias voltage can be set (e.g.,  $V_{BIAS1}$ ) and a resulting current will be sensed (e.g.,  $I_{SENSE1}$ ). As the voltage decreases (e.g.,  $V_{BIAS2}$ ) due to reference voltage drift, for example, a new resulting current is sensed (e.g.,  $I_{SENSE2}$ ). Therefore, the change in bias is an indicator of signal artifacts and can be used in signal estimation and to replace the erroneous resulting signals. In addition to ischemia, the local environment at the electrode surfaces can affect the CV curve, for example, changes in pH, temperature, and other local biochemical species can significantly alter the location of the CV curve.

[0314] FIG. 10C is a CV curve that illustrates an alternative embodiment of signal artifacts detection, wherein pH

and/or temperature can be monitoring using the CV curve and diagnosed to detect transient non-glucose related signal artifacts. For example, signal artifacts can be attributed to thermal changes and/or pH changes in some embodiments because certain changes in pH and temperature affect data from a glucose sensor that relies on an enzymatic reaction to measure glucose. Signal artifacts caused by pH changes, temperature changes, changes in available electrode surface area, and other local biochemical species can be detected and signal estimation can be applied an/or optimized such as described in more detail elsewhere herein. In FIG. 10C, a first curve 108 illustrates an expected CV curve when the potentiostat is functioning normally. A second curve 109 illustrates a CV curve wherein the environment has changed as indicated by the upward shift of the CV curve.

[0315] In some embodiments, pH and/or temperature measurements are obtained proximal to the glucose sensor; in some embodiments, pH and/or temperature measurements are also obtained distal to the glucose sensor and the respective measurements compared, such as described in more detail above with reference to oxygen sensors.

[0316] In another implementation of signal artifacts detection, wherein temperature is detected, an electronic thermometer can be proximal to or within the glucose sensor, such that the temperature measurement is representative of the temperature of the glucose sensor's local environment. It is noted that accurate sensor function depends on diffusion of molecules from the blood to the interstitial fluid, and then through the membranes of the device to the enzyme membrane. Additionally, diffusion transport of hydrogen peroxide from the enzyme membrane to the electrode is required for accurate sensor function in some embodiments. Therefore, temperatures can be a rate determining parameter of diffusion. As temperature decreases, diffusion transport decreases. Under certain human conditions, such as hypothermia or fever, the variations can be considerably greater. Additionally, under normal conditions, the temperature of subcutaneous tissue is known to vary considerably more than core tissues (e.g., core temperature). Temperature thresholds can be set to detect signal artifacts accordingly.

[0317] In another implementation, a pH detector is used to detect signal artifacts. In glucose sensors that rely on enzymatic reactions, a pH of the fluid to be sensed can be within the range of about 5.5 to 7.5. Outside of this range, effects may be seen in the enzymatic reaction and therefore data output of the glucose sensor. Accordingly, by detecting if the pH is outside of a predetermined range (e.g., 5.5 to 7.5), a pH detector may detect transient non-glucose related signal artifacts such as described herein. It is noted that the pH threshold can be set at ranges other than provided herein without departing from the preferred embodiments.

[0318] In an alternative embodiment of signal artifacts detection, pressure and/or stress can be monitored using known techniques for example by a strain gauge placed on the sensor that detects stress/strain on the circuit board, sensor housing, or other components. A variety of microelectromechanical systems (MEMS) can be utilized to measure pressure and/or stress within the sensor.

[0319] In another alternative embodiment of signal artifacts detection, the processor in the sensor (or receiver) periodically evaluates the data stream for high amplitude noise, which is defined by noisy data wherein the amplitude

of the noise is above a predetermined threshold. For example, in the graph of FIGS. 7A and 7B, the system noise sections such as 72a and 72b have a substantially low amplitude noise threshold; in contrast to system noise, signal artifacts sections such as 74a and 74b have signal artifacts (noise) with an amplitude that is much higher than that of system noise. Therefore, a threshold can be set at or above the amplitude of system noise, such that when noisy data is detected above that amplitude, it can be considered "signal artifacts" as defined herein.

[0320] In another alternative embodiment of signal artifacts detection, a method hereinafter referred to as the "Cone of Possibility Detection Method," utilizes physiological information along with glucose signal values in order define a "cone" of physiologically feasible glucose signal values within a human, such that signal artifacts are detected whenever the glucose signal falls outside of the cone of possibility. Particularly, physiological information depends upon the physiological parameters obtained from continuous studies in the literature as well as our own observations. A first physiological parameter uses a maximal sustained rate of change of glucose in humans (e.g., about 4 to 5 mg/dL/min) and a maximum acceleration of that rate of change (e.g., about 0.1 to 0.2 mg/dL/min<sup>2</sup>). A second physiological parameter uses the knowledge that rate of change of glucose is lowest at the minima, which is the areas of greatest risk in patient treatment, and the maxima, which has the greatest long-term effect on secondary complications associated with diabetes. A third physiological parameter uses the fact that the best solution for the shape of the curve at any point along the curve over a certain time period (e.g., about 20-30 minutes) is a straight line. Additional physiological parameters can be incorporated and are within the scope of this embodiment.

[0321] In practice, the Cone of Possibility Detection Method combines any one or more of the above-described physiological parameters to form an algorithm that defines a cone of possible glucose levels for glucose data captured over a predetermined time period. In one exemplary implementation of the Cone of Possibility Detection Method, the system (processor in the sensor or receiver) calculates a maximum physiological rate of change and determines if the data falls within these physiological limits; if not, signal artifacts are identified. It is noted that the maximum rate of change can be narrowed (e.g., decreased) in some instances. Therefore, additional physiological data could be used to modify the limits imposed upon the Cone of Possibilities Detection Method for sensor glucose values. For example, the maximum per minute rate change can be lower when the subject is sleeping or hasn't eaten in eight hours; on the other hand, the maximum per minute rate change can be higher when the subject is exercising or has consumed high levels of glucose, for example. In general, it has been observed that rates of change are slowest near the maxima and minima of the curve, and that rates of change are highest near the midpoint between the maxima and minima. It should further be noted that rate of change limits are derived from analysis of a range of data significantly higher unsustained rates of change can be observed.

[0322] In another alternative embodiment of signal artifacts detection, examination of the spectral content (e.g., frequency content) of the data stream can yield measures useful in detecting signal artifacts. For example, data that



has high frequency, and in some cases can be characterized by a large negative slope, are indicative of signal artifacts and can cause sensor signal loss. Specific signal content can be monitored using an orthogonal transform, for example a Fourier transform, a Discrete Fourier Transform (DFT), or any other method known in the art.

[0323] FIG. 11 is a graph of 110 a raw data stream from a glucose sensor and a spectrogram 114 that shows the frequency content of the raw data stream in one embodiment. Particularly, the graph 110 illustrates the raw data stream 112 and includes an x-axis that represents time in hours and a y-axis that represents sensor data output in counts; the spectrogram 114 illustrates the frequency content 116 corresponding to the raw data stream 112 and includes an x-axis that represents time in hours corresponding to the x-axis of the graph 110 and a y-axis that represents frequency content in cycles per hour. The darkness of each point represents the amplitude of that frequency at that time. Darker points relate to higher amplitudes. Frequency content on the spectrogram 114 was obtained using a windowed Discrete Fourier transform.

[0324] The raw data stream in the graph 110 has been adjusted by a linear mapping similar to the calibration algorithm. In this example, the bias (or intercept) has been adjusted but not the proportion (or slope). The slope of the raw data stream would typically be determined by some calibration, but since the calibration has not occurred in this example, the gray levels in the spectrogram 114 indicate relative values. The lower values of the graph 110 are white. They are colored as white below a specific value, highlighting only the most intense areas of the graph.

[0325] By monitoring the frequency content 116, high frequency cycles 118 can be observed. The high frequency cycles 118 correspond to signal artifacts 119 such as described herein. Thus, signal artifacts can be detected on a data stream by monitoring frequency content and setting a threshold (e.g., 30 cycles per hour). The set threshold can vary depending on the signal source.

[0326] In another alternative embodiment of signal artifacts detection, examination of the signal information content can yield measures useful in detecting signal artifacts. Time series analysis can be used to measure entropy, approximate entropy, variance, and/or percent change of the information content over consecutive windows (e.g., 30 and 60 minute windows of data) of the raw data stream. In one exemplary embodiment, the variance of the raw data signal is measured over 15 minute and 45 minute windows, and signal artifacts are detected when the variance of the data within the 15-minute window exceeds the variance of the data within the 45-minute window. Alternatively, other methods of self-diagnosis can be performed on the signal to determine a level of signal artifacts. One example includes performing a first derivative analysis that compares consecutive points, and detects signal artifacts when point to point changes are above a physiologically feasible threshold, for example. Another example of signal self-diagnosis includes performing a second derivative analysis that considers turning points, for example, detects signal artifacts when changes are not sufficiently gradual (e.g., within thresholds), for example.

[0327] In yet another alternative embodiment of signal artifacts detection that utilizes examination or evaluation of

the signal information content, filtered (e.g., smoothed) data is compared to raw data (e.g., in sensor electronics or in receiver electronics). In one such embodiment, a signal residual is calculated as the difference between the filtered data and the raw data. For example, at one time point (or one time period that is represented by a single raw value and single filtered value), the filtered data can be measured at 50,000 counts and the raw data can be measured at 55,500 counts, which would result in a signal residual of 5,500 counts. In some embodiments, a threshold can be set (e.g., 5000 counts) that represents a first level of noise (e.g., signal artifact) in the data signal, when the residual exceeds that level. Similarly, a second threshold can be set (e.g., 8,000 counts) that represents a second level of noise in the data signal. Additional thresholds and/or noise classifications can be defined as is appreciated by one skilled in the art. Consequently, signal filtering, processing, and/or displaying decisions can be executed based on these conditions (e.g., the predetermined levels of noise).

[0328] Although the above-described example illustrates one method of determining a level of noise, or signal artifact(s), based on a comparison of raw vs. filtered data for a time point (or single values representative of a time period). In an alternative exemplary embodiment for determining noise, signal artifacts are evaluated for noise episodes lasting a certain period of time. For example, the processor (in the sensor or receiver) can be configured to look for a certain number of signal residuals above a predetermined threshold (representing noise time points or noisy time periods) for a predetermined period of time (e.g., a few minutes to a few hours or more).

[0329] In one exemplary embodiment, a processor is configured to determine a signal residual by subtracting the filtered signal from the raw signal for a predetermined time period. It is noted that the filtered signal can be filtered by any known smoothing algorithm such as described herein, for example a 3-point moving average-type filter. It is further noted that the raw signal can include an average value, e.g., wherein the value is integrated over a predetermined time period (such as 5-minutes). Furthermore, it is noted that the predetermined time period can be a time point or representative data for a time period (e.g., 5 minutes). In some embodiments, wherein a noise episode for a predetermined time period is being evaluated, a differential can be obtained by comparing a signal residual with a previous signal residual (e.g., a residual at time  $(t)=0$  as compared to a residual at  $(t)-5$  minutes.) Similar to the thresholds described above with regard to the signal residual, one or more thresholds can be set for the differentials, whereby one or more differentials above one of the predetermined differential thresholds defines a particular noise level. It has been shown in certain circumstances that a differential measurement as compared to a residual measurement as described herein, amplifies noise and therefore may be a more sensitive to noise episodes. Accordingly, a noise episode, or noise episode level, can be defined by one or more points (e.g., residuals or differentials) above a predetermined threshold, and in some embodiments, for a predetermined period of time. Similarly, a noise level determination can be reduced or altered when a different (e.g., reduced) number of points above the predetermined threshold are calculated in a predetermined period of time.

[0330] One or a plurality of the above signal artifacts detection models can be used alone or in combination to detect signal artifacts such as described herein. Accordingly, the data stream associated with the signal artifacts can be discarded, replaced, or otherwise processed in order to reduce or eliminate these signal artifacts and thereby improve the value of the glucose measurements that can be provided to a user.

#### Signal Artifacts Replacement

[0331] Signal Artifacts Replacement, such as described above, can use systems and methods that reduce or replace these signal artifacts that can be characterized by transience, high frequency, high amplitude, and/or substantially non-linear noise. Accordingly, a variety of filters, algorithms, and other data processing are provided that address the detected signal artifacts by replacing the data stream, or portion of the data stream, with estimated glucose signal values. It is noted that “signal estimation” as used herein, is a broad term, which includes filtering, data smoothing, augmenting, projecting, and/or other algorithmic methods that estimate glucose signal values based on present and historical data.

[0332] It is noted that a glucose sensor can contain a processor and the like that processes periodically received raw sensor data (e.g., every 30 seconds). Although a data point can be available constantly, for example by use of an electrical integration system in a chemo-electric sensor, relatively frequent (e.g., every 30 seconds), or less frequent data point (e.g., every 5 minutes), can be more than sufficient for patient use. It is noted that accordingly Nyquist Theory, a data point is required about every 10 minutes to accurately describe physiological change in glucose in humans. This represents the lowest useful frequency of sampling. However, it should be recognized that it is desirable to sample more frequently than the Nyquist minimum, to provide for sufficient data in the event that one or more data points are lost, for example. Additionally, more frequently sampled data (e.g., 30-second) can be used to smooth the less frequent data (e.g., 5-minute) that are transmitted. It is noted that in this example, during the course of a 5-minute period, 10 determinations are made at 30-second intervals.

[0333] In some embodiments of Signal Artifacts Replacement, signal estimation can be implemented in the sensor and transmitted to a receiver for additional processing. In some embodiments of Signal Artifacts Replacement, raw data can be sent from the sensor to a receiver for signal estimation and additional processing therein. In some embodiments of Signal Artifacts Replacement, signal estimation is performed initially in the sensor, with additional signal estimation in the receiver.

[0334] In some embodiments of Signal Artifacts Replacement, wherein the sensor is an implantable glucose sensor, signal estimation can be performed in the sensor to ensure a continuous stream of data. In alternative embodiments, data can be transmitted from the sensor to the receiver, and the estimation performed at the receiver; It is noted however that there can be a risk of transmit-loss in the radio transmission from the sensor to the receiver when the transmission is wireless. For example, in embodiments wherein a sensor is implemented in vivo, the raw sensor signal can be more consistent within the sensor (in vivo) than the raw signal transmitted to a source (e.g., receiver) outside the body (e.g., if a patient were to take the receiver off to shower,

communication between the sensor and receiver can be lost and data smoothing in the receiver would halt accordingly). Consequently, It is noted that a multiple point data loss in the filter can take for example, about 25 to about 40 minutes for the data to recover to near where it would have been had there been no data loss.

[0335] In some embodiments of Signal Artifacts Replacement, signal estimation is initiated only after signal artifacts are positively detected and stopped once signal artifacts are negligibly detected. In some alternative embodiments signal estimation is initiated after signal artifacts are positively detected and then stopped after a predetermined time period. In some alternative embodiments, signal estimation can be continuously or continually performed. In some alternative embodiments, one or more forms of signal estimation can be accomplished based on the severity of the signal artifacts, such as will be described with reference the section entitled, “Selective Application of Signal Artifacts Replacement.”

[0336] In some embodiments of Signal Artifacts Replacement, the processor performs a linear regression. In one such implementation, the processor performs a linear regression analysis of the  $n$  (e.g., 10) most recent sampled sensor values to smooth out the noise. A linear regression averages over a number of points in the time course and thus reduces the influence of wide excursions of any point from the regression line. Linear regression defines a slope and intercept, which is used to generate a “Projected Glucose Value,” which can be used to replace sensor data. This regression can be continually performed on the data stream or continually performed only during the transient signal artifacts. In some alternative embodiments, signal estimation can include non-linear regression.

[0337] In another embodiment of Signal Artifacts Replacement, the processor performs a trimmed regression, which is a linear regression of a trimmed mean (e.g., after rejecting wide excursions of any point from the regression line). In this embodiment, after the sensor records glucose measurements at a predetermined sampling rate (e.g., every 30 seconds), the sensor calculates a trimmed mean (e.g., removes highest and lowest measurements from a data set and then regresses the remaining measurements to estimate the glucose value.

[0338] FIG. 12 is a graph that illustrates a raw data stream from a glucose sensor and a trimmed regression that can be used to replace some of or the entire data stream. The x-axis represents time in minutes; the y-axis represents sensor data output in counts. A raw data signal 120, which is illustrated as a dotted line, shows a data stream wherein some system noise can be detected, however signal artifacts 122 can be particularly seen in a portion thereof (and can be detected by methods such as described above). The trimmed regression line 124, which is illustrated as a solid line, is the data stream after signal estimation using a trimmed linear regression algorithm, such as described above, and appears at least somewhat “smoothed” on the graph. In this particular example, the trimmed regression uses the most recent 60 points (30 minutes) and trims out the highest and lowest values, then uses the leftover 58 points to project the next point. It is noted that the trimmed regression 124 provides a good estimate throughout the majority data stream, however is only somewhat effective in smoothing the data in during signal artifacts 122. To provide an optimized estimate of the

glucose data values, the trimmed regression can be optimized by changing the parameters of the algorithm, for example by trimming more or less raw glucose data from the top and/or bottom of the signal artifacts **122** prior to regression. Additionally, trimmed regression, because of its inherent properties, can be particularly suited for noise of a certain amplitude and/or characteristic. In one embodiment, for example trimmed regression can be selectively applied based on the severity of the signal artifacts, which is described in more detail below with reference to FIGS. **15** to **17**.

[0339] In another embodiment of Signal Artifacts Replacement, the processor runs a non-recursive filter, such as a finite impulse response (FIR) filter. A FIR filter is a digital signal filter, in which every sample of output is the weighted sum of past and current samples of input, using only some finite number of past samples.

[0340] FIG. **13** is a graph that illustrates a raw data stream from a glucose sensor and an FIR-estimated signal that can be used to replace some of or the entire data stream. The x-axis represents time in minutes; the y-axis represents sensor data output in counts. A raw data signal **130**, which is illustrated as a dotted line, shows a data stream wherein some system noise can be detected, however signal artifacts **132** can be particularly seen in a portion thereof (and can be detected by methods such as described above). The FIR-estimated signal **134**, which is illustrated as a solid line, is the data stream after signal estimation using a FIR filter, such as described above, and appears at least somewhat "smoothed" on the graph. It is noted that the FIR-estimated signal provides a good estimate throughout the majority of the data stream; however like trimmed regression it is only somewhat effective in smoothing the data during signal artifacts **132**. To provide an optimized estimate of the glucose data values, the FIR filter can be optimized by changing the parameters of the algorithm, for example the tuning of the filter, particularly the frequencies of the pass band and the stop band. Additionally, it is noted that the FIR filter, because of its inherent properties, can be particularly suited for noise of a certain amplitude and/or characteristic. In one embodiment, for example the FIR filter can be selectively applied based on the severity of the signal artifacts, which is described in more detail below with reference to FIGS. **15** to **17**. It is noted that the FIR-estimated signal induces a time lag on the data stream, which can be increased or decreased in order to optimize the filtering or to minimize the time lag, for example.

[0341] In another embodiment of Signal Artifacts Replacement, the processor runs a recursive filter, such as an infinite impulse response (IIR) filter. An IIR filter is a type of digital signal filter, in which every sample of output is the weighted sum of past and current samples of input. In one exemplary implementation of an IIR filter, the output is computed using 6 additions/subtractions and 7 multiplications as shown in the following equation:

$$y(n) = \frac{a_0 * x(n) + a_1 * x(n-1) + a_2 * x(n-2) + a_3 * x(n-3) - b_1 * y(n-1) - b_2 * y(n-2) - b_3 * y(n-3)}{b_0}$$

This polynomial equation includes coefficients that are dependent on sample rate and frequency behavior of the

filter. Frequency behavior passes low frequencies up to cycle lengths of 40 minutes, and is based on a 30 second sample rate. In alternative implementations, the sample rate and cycle lengths can be more or less. See Lynn "Recursive Digital Filters for Biological Signals" Med. & Biol. Engineering, Vol. 9, pp. 37-43, which is incorporated herein by reference in its entirety.

[0342] FIG. **14** is a graph that illustrates a raw data stream from a glucose sensor and an IIR-estimated signal that can be used to replace some of or the entire data stream. The x-axis represents time in minutes; the y-axis represents sensor data output in counts. A raw data signal **140**, which is illustrated as a dotted line, shows a data stream wherein some system noise can be detected, however signal artifacts **142** can be particularly seen in a portion thereof (and can be detected by methods such as described above). The IIR-estimated signal **144**, which is illustrated as a solid line, represents the data stream after signal estimation using an IIR filter, such as described above, and appears at least somewhat "smoothed" on the graph. It is noted that the IIR-estimated signal induces a time lag on the data stream; however it appears to be a particularly good estimate of glucose data values during signal artifacts **142**, as compared to the FIR filter (FIG. **13**), for example.

[0343] To optimize the estimation of the glucose data values, the parameters of the IIR filter can be optimized, for example by increasing or decreasing the cycle lengths (e.g., 10 minutes, 20 minute, 40 minutes, 60 minutes) that are used in the algorithm. Although an increased cycle length can increase the time lag induced by the IIR filter, an increased cycle length can also better estimate glucose data values during severe signal artifacts. In other words, the IIR filter, because of its inherent properties, can be particularly suited for noise of a certain amplitude and/or characteristic. In one exemplary embodiment, the IIR filter can be continually applied, however the parameters such as described above can be selectively altered based on the severity of the signal artifacts; in another exemplary embodiment, the IIR filter can be applied only after positive detection of signal artifacts. Selective application of the IIR filter based on the severity of the signal artifacts is described in more detail below with reference to FIGS. **15** to **17**.

[0344] It is noted that a comparison of linear regression, an FIR filter, and an IIR filter can be advantageous for optimizing their usage in the preferred embodiments. That is, an understanding the design considerations for each algorithm can lead to optimized selection and implementation of the algorithm, as described in the section entitled, "Selective Application of Signal Replacement Algorithms" herein. During system noise, as defined herein, all of the above algorithms can be successfully implemented during system noise with relative ease. During signal artifacts, however, computational efficiency is greater with an IIR-filter as compared with linear regression and FIR-filter. Additionally, although the time lag associated with an IIR filter can be substantially greater than that of the linear regression or FIR-filter, this can be advantageous during severe signal artifacts in order to assign greater weight toward the previous, less noisy data in signal estimation.

[0345] In another embodiment of Signal Artifacts Replacement, the processor runs a maximum-average (max-average) filtering algorithm. The max-average algorithm

smoothes data based on the discovery that the substantial majority of signal artifacts observed after implantation of glucose sensors in humans, for example, is not distributed evenly above and below the actual blood glucose levels. It has been observed that many data sets are actually characterized by extended periods in which the noise appears to trend downwardly from maximum values with occasional high spikes such as described in more detail above with reference to FIG. 7B, section 74b, which is likely in response to limitations in the system that do not allow the glucose to fully react at the enzyme layer and/or proper reduction of  $H_2O_2$  at the counter electrode, for example. To overcome these downward trending signal artifacts, the max-average calculation tracks with the highest sensor values, and discards the bulk of the lower values. Additionally, the max-average method is designed to reduce the contamination of the data with non-physiologically high data from the high spikes.

[0346] The max-average calculation smoothes data at a sampling interval (e.g., every 30 seconds) for transmission to the receiver at a less frequent transmission interval (e.g., every 5 minutes) to minimize the effects of low non-physiological data. First, the processor finds and stores a maximum sensor counts value in a first set of sampled data points (e.g., 5 consecutive, accepted, thirty-second data points). A frame shift time window finds a maximum sensor counts value for each set of sampled data (e.g., each 5-point cycle length) and stores each maximum value. The processor then computes a rolling average (e.g., 5-point average) of these maxima for each sampling interval (e.g., every 30 seconds) and stores these data. Periodically (e.g., every 10<sup>th</sup> interval), the sensor outputs to the receiver the current maximum of the rolling average (e.g., over the last 10 thirty-second intervals as a smoothed value for that time period (e.g., 5 minutes)). In one example implementation, a 10-point window can be used, and at the 10<sup>th</sup> interval, the processor computes the average of the most recent 5 or 10 average maxima as the smoothed value for a 5 minute time period.

[0347] In some embodiments of the max-average algorithm, an acceptance filter can also be applied to new sensor data to minimize effects of high non-physiological data. In the acceptance filter, each sampled data point (e.g., every 30 seconds) is tested for acceptance into the maximum average calculation. Each new point is compared against the most representative estimate of the sensor curve at the previous sampling interface (e.g., 30-second time point), or at a projection to a current estimated value. To reject high data, the current data point is compared to the most recent value of the average maximum values over a time period (e.g., 5 sampled data points over a 2.5 minute period). If the ratio of current value to the comparison value is greater than a certain threshold (e.g., about 1.02), then the current data point is replaced with a previously accepted value (e.g., 30-second value). If the ratio of current value to the comparison value is in at or within a certain range (e.g., about 1.02 to 0.90), then the current data point is accepted. If the ratio of current value to the comparison value is less than a certain threshold (e.g., about 0.90), then the current data point is replaced with a previously accepted value. The acceptance filter step and max-average calculation are continuously run throughout the data set (e.g., fixed 5-minute windows) on a rolling window basis (e.g., every 30 seconds).

[0348] In some implementations of the acceptance filter, the comparison value for acceptance could also be the most recent maximum of 5 accepted sensor points (more sensitive) or the most recent average over 10 averages of 5 maximum values (least sensitive), for example. In some exemplary implementations of the acceptance filter, the projected value for the current time point can be based on regression of the last 4 accepted 30-second values and/or the last 2 to 4 (5 to 15 min) of the 5-minute smoothed values, for example. In some exemplary implementations of the acceptance filter, the percentage comparisons of +2% and -10% of counts value would be replaced by percentage comparisons based on the most recent 24 hour range of counts values; this method would provide improved sensor specificity as compared to a method based on total counts.

[0349] In another embodiment of Signal Artifacts Replacement, the processor runs a "Cone of Possibility Replacement Method." It is noted that this method can be performed in the sensor and/or in the receiver. The Cone of Possibility Detection Method utilizes physiological information along with glucose signal values in order to define a "cone" of physiologically feasible glucose signal values within a human. Particularly, physiological information depends upon the physiological parameters obtained from continuous studies in the literature as well as our own observations. A first physiological parameter uses a maximal sustained rate of change of glucose in humans (e.g., about 4 to 5 mg/dl/min) and a maximum sustained acceleration of that rate of change (e.g., about 0.1 to 0.2 mg/min/min). A second physiological parameter uses the knowledge that rate of change of glucose is lowest at the maxima and minima, which are the area of greatest risk in patient treatment, such as described with reference to Cone of Possibility Detection, above. A third physiological parameter uses the fact that the best solution for the shape of the curve at any point along the curve over a certain time period (e.g., about 20-25 minutes) is a straight line. It is noted that the maximum rate of change can be narrowed in some instances. Therefore, additional physiological data can be used to modify the limits imposed upon the Cone of Possibility Replacement Method for sensor glucose values. For example, the maximum per minute rate change can be lower when the subject is lying down or sleeping; on the other hand, the maximum per minute rate change can be higher when the subject is exercising, for example.

[0350] The Cone of Possibility Replacement Method utilizes physiological information along with blood glucose data in order to improve the estimation of blood glucose values within a human in an embodiment of Signal Artifacts Replacement. The Cone of Possibility Replacement Method can be performed on raw data in the sensor, on raw data in the receiver, or on smoothed data (e.g., data that has been replaced/estimated in the sensor or receiver by one of the methods described above) in the receiver.

[0351] In a first implementation of the Cone of Possibility Replacement Method, a centerline of the cone can be projected from a number of previous, optionally smoothed, incremental data points (e.g., previous four, 5-minute data points). Each predicted cone centerline point (e.g., 5 minute point) increases by the slope (S) (e.g., for the regression in counts/minute) multiplied by the data point increment (e.g., 5 minutes). Counts/mg/dL is estimated from glucose and sensor range calculation over the data set.

[0352] In this first implementation of the Cone of Possibility Replacement Method, positive and negative cone limits are simple linear functions. Periodically (e.g., every 5 minutes), each sensor data point (optionally smoothed) is compared to the cone limits projected from the last four points. If the sensor value observed is within the cone limits, the sensor value is retained and used to generate the cone for the next data point increment (e.g., 5-minute point). If the sensor value observed falls outside the high or low cone limit, the value is replaced by the cone limit value, and that value is used to project the next data point increment (e.g., 5 minute point, high point, or low point). For example, if the difference between two adjacent 5-minute points exceeds 20 mg/dL, then cone limits are capped at 20 mg/dL increments per 5 minutes, with the positive limit of the cone being generated by the addition of  $0.5 * A * t^2$  to mid cone value, where A is 0.1 mg/dL/min/min and t is 5 minute increments (A is converted to counts/min/min for the calculation), and the negative limit of the cone being generated by the addition of  $-0.5 * A * t^2$  to mid cone value. This implementation provides a high degree of accuracy and is minimally sensitive to non-physiological rapid changes.

[0353] The following Table 1 illustrates one example implementation of the Cone of Possibility Replacement Method, wherein the maximum sustained value observed for S is about  $\pm 4$  mg/dL/min and the maximum value observed for A is about  $\pm 0.1$  mg/dL/min<sup>2</sup>:

TABLE 1

Time	Mid line (mg/dL)	Positive Cone Limit	Negative Cone Limit
0	100	100	100
5	$100 + 5 * S$	$100 + 5 * S + 12.5 * A$	$100 + 5 * S - 12.5A$
10	$100 + 10 * S$	$100 + 10 * S + 50 * A$	$100 + 10 * S - 50 * A$
15	$100 + 15 * S$	$100 + 15 * S + 112.5 * A$	$100 + 15 * S - 112.5 * A$
20	$100 + 20 * S$	$100 + 20 * S + 200 * A$	$100 + 20 * S - 200 * A$
25	$100 + 25 * S$	$100 + 25 * S + 312.5 * A$	$100 + 25 * S - 312.5 * A$

[0354] The cone widens for each 5-minute increment for which a sensor value fails to fall inside the cone up to 30 minutes, such as can be seen in the table above. At 30 minutes, a cone has likely widened enough to capture an observed sensor value, which is used, and the cone collapses back to a 5-minute increment width. If no sensor values are captured within 30 minutes, the cone generation routine starts over using the next four observed points. In some implementations special rules can be applied, for example in a case where the change in counts in one 5-minute interval exceeds an estimated 30-mg/dL amount. In this case, the next acceptable point can be more than 20 to 30 minutes later. It is noted that an implementation of this algorithm includes utilizing the cone of possibility to predict glucose levels and alert patients to present or upcoming dangerous blood glucose levels.

[0355] In another alternative embodiment of cone widening, the cone can widen in set multiples (e.g., 20 mg/dL) of equivalent amounts for each additional time interval (e.g., 5 minutes), which rapidly widens the cone to accept data.

[0356] It is noted that the numerical parameters represent only one example implementation of the Cone of Possibility Replacement Method. The concepts can be applied to any numerical parameters as desired for various glucose sensor applications.

[0357] In another implementation of the Cone of Possibility Replacement Method, sensor calibration data is optimized using the Clarke Error Grid, the Consensus Grid, or an alternative error assessment that assigns risk levels based on the accuracy of matched data pairs. In an example using the Clarke Error Grid, because the 10 regions of the Clarke Error Grid are not all symmetric around the Y=X perfect regression, fits to the grid can be improved by using a multi-line regression to the data.

[0358] Accordingly the pivot point method for the counts vs. glucose regression fit can be used to optimize sensor calibration data to the Clarke Error Grid, Consensus Grid, or other clinical acceptability standard. First, the glucose range is divided according to meter values (e.g., at 200 mg/dL). Two linear fitting lines are used, which cross at the pivot point. The coordinates of the pivot point in counts and glucose value, plus the slope and intercept of the two lines are variable parameters. Some of pivot point coordinates (e.g., 4 out of 6) and slope or intercept of each line can be reset with each iteration, while the chosen coordinates define the remainder. The data are then re-plotted on the Clarke Error Grid, and changes in point placement and percentages in each region of the grid are evaluated. To optimize the fit of a data set to a Clark Error Grid, the regression of counts vs. reference glucose can be adjusted such that the maximum number of points are in the A+B zones without reducing the A+B percentage, and the number of points are optimized such that the highest percentage are in the A zone and lowest percentage are in the D, E and C zones. In general, the points should be distributed as evenly as possible around the Y=X line. In some embodiments, three distinct lines optimized for clinical acceptability can represent the regression line. In some embodiments, an additional useful criterion can be used to compute the root mean squared percentage bias for the data set. Better fits are characterized by reduction in the total root mean squared percentage bias. In an alternative implementation of the pivot point methods, a predetermined pivot (e.g., 10 degree) of the regression line can be applied when the estimated blood is above or below a set threshold (e.g., 150 mg/dL), wherein the pivot and threshold are determined from a retrospective analysis of the performance of a conversion function and its performance at a range of glucose concentrations.

[0359] In another embodiment of Signal Artifacts Replacement, reference changes in electrode potential can be used to estimate glucose sensor data during positive detection of signal artifacts from an electrochemical glucose sensor, the method hereinafter referred to as reference drift replacement. In this embodiment, the electrochemical glucose sensor comprises working, counter, and reference electrodes, such as described with reference to FIGS. 1, 2 and 10 above. This method exploits the function of the reference electrode as it drifts to compensate for counter electrode limitations during oxygen deficits, pH changes, and/or temperature changes such as described in more detail above with reference to FIGS. 10A, 10B, and 10C.

[0360] Such as described with in more detail with reference to FIG. 10A a potentiostat is generally designed so that

a regulated potential difference between the reference electrode **102** and working electrode **100** is maintained as a constant. The potentiostat allows the counter electrode voltage to float within a certain voltage range (e.g., from between close to the +1.2V observed for the working electrode to as low as battery ground or 0.0V). The counter electrode voltage measurement will reside within this voltage range dependent on the magnitude and sign of current being measured at the working electrode and the electroactive species type and concentration available in the electrolyte adjacent to the counter electrode **104**. This species will be electrochemically recruited (e.g., reduced/accepting electrons) to equal the current of opposite sign (e.g., oxidized/donating electrons) occurring at the working electrode **100**. It has been discovered that the reduction of dissolved oxygen or hydrogen peroxide from oxygen converted in the enzyme layer are the primary species reacting at the counter electrode to provide this electronic current balance in this embodiment. If there are inadequate reducible species (e.g., oxygen) available for the counter electrode, or if other non-glucose reaction rate limiting phenomena occur (e.g., temperature or pH), the counter electrode can be driven in its electrochemical search for electrons all the way to ground or 0.0V. However, regardless of the voltage in the counter electrode, the working and counter electrode currents must still maintain substantially equivalent currents. Therefore, the reference electrode **102** will drift upward creating new oxidizing and reducing potentials that maintain equal currents at the working and counter electrodes.

[0361] Because of the function of the reference electrode **102**, including the drift that occurs during periods of signal artifacts (e.g., ischemia), the reference electrode can be monitored to determine the severity of the signal artifacts on the data stream. Particularly, a substantially direct relationship between the reference electrode drift and signal artifacts has been discovered. Using the information contained within the CV curve (FIGS. **10B** and/or **10C**), the measured glucose signal ( $I_{\text{SENSE}}$ ) can be automatically scaled accordingly to replace these undesired transient effects on the data stream. It is noted that the circuit described with reference to FIG. **10A** can be used to determine the CV curve on a regularly scheduled basis or as needed. To this end, the desired reference voltage and applied potential are made variable, and the reference voltage can be changed at a defined rate while measuring the signal strength from the working electrode, which allows for generation of a CV curve while a sensor is in vivo.

[0362] In alternative implementations of the reference drift replacement method, a variety of algorithms can therefore be implemented that replaces the signal artifacts based on the changes measured in the reference electrode. Linear algorithms, and the like, are suitable for interpreting the direct relationship between reference electrode drift and the non-glucose rate limiting signal noise such that appropriate conversion to signal noise compensation can be derived.

[0363] In other embodiments of Signal Artifacts Replacement, prediction algorithms, also referred to as projection algorithms, can be used to replace glucose data signals for data which does not exist because 1) it has been discarded, 2) it is missing due to signal transmission errors and the like, or 3) it represents a time period (e.g., future) for which a data stream has not yet been obtained based on historic and/or present data. Prediction/projection algorithms include any of

the above described Signal Artifacts Replacement algorithms, and differ only in the fact that they are implemented to replace time points/periods during which no data is available (e.g., for the above-described reasons), rather than including that existing data, within the algorithmic computation.

[0364] In some embodiments, signal replacement/estimation algorithms are used to predict where the glucose signal should be, and if the actual data stream varies beyond a certain threshold of that projected value, then signal artifacts are detected. In alternative embodiments, other data processing can be applied alone, or in combination with the above-described methods, to replace data signals during system noise and/or signal artifacts.

#### Selective Application of Signal Replacement Algorithms

[0365] FIG. **15** is a flow chart that illustrates a process of selectively applying signal estimation in embodiments.

[0366] At block **152**, a sensor data receiving module, also referred to as the sensor data module, receives sensor data (e.g., a data stream), including one or more time-spaced sensor data points, such as described in more detail with reference to block **82** in FIG. **8**.

[0367] At block **154**, a signal artifacts detection module, also referred to as the signal artifacts detector **154**, is programmed to detect transient non-glucose related signal artifacts in the data stream that have a higher amplitude than system noise, such as described in more detail with reference to block **84** in FIG. **8**. However, the signal artifacts detector of this embodiment can additionally detect a severity of signal artifacts. In some embodiments, the signal artifacts detector has one or more predetermined thresholds for the severity of the signal artifacts (e.g., low, medium, and high). In some embodiments, the signal artifacts detector numerically represents the severity of signal artifacts based on a calculation for example, which representation can be used to apply to the signal estimation algorithm factors, such as described in more detail with reference to block **156**.

[0368] In one exemplary embodiment, the signal artifacts detection module evaluates the amplitude and/or frequency of the transient non-glucose related signal artifacts, which amplitude and/or frequency can be used to define the severity in terms of a threshold (e.g., high or low) or a numeric representation (e.g., a value from 1 to 10). In another exemplary embodiment, the signal artifacts detection module evaluates a duration of the transient non-glucose related signal artifacts, such that as the duration increases, a severity can be defined in terms of a threshold (e.g., short or long) or a numeric representation (e.g., 10, 20, 30, 40, 50, or 60 minutes). In another exemplary embodiment, the signal artifacts detection module evaluates the frequency content from a Fourier Transform and defines severity in terms of a threshold (e.g., above or below 30 cycles per hour) or a numeric representation (e.g., 50 cycles per hour). All of the signal artifacts detection methods described herein can be implemented to include determining a severity of the signal artifacts, threshold, and/or numerical representations.

[0369] At block **156**, the signal artifacts replacement module, also referred to as the signal estimation module, selectively applies one of a plurality of signal estimation algorithm factors in response to the severity of said signal artifacts.

[0370] In one embodiment, signal artifacts replacement is normally turned off, except during detected signal artifacts. In another embodiment, a first signal estimation algorithm (e.g., linear regression, FIR filter etc.) is turned on all the time, and a second signal estimation algorithm optimized for signal artifacts (e.g., IIR filter, Cone of Possibility Replacement Method, etc.) is turned on only during positive detection of signal artifacts.

[0371] In another embodiment, the signal replacement module comprises programming to selectively switch on and off a plurality of distinct signal estimation algorithms based on the severity of the detected signal artifacts. For example, the severity of the signal artifacts can be defined as high and low. In such an example, a first filter (e.g., trimmed regression, linear regression, FIR, Reference Electrode Method, etc.) can be applied during low signal artifacts and a second filter (e.g., IIR, Cone of Possibility Method, etc.) can be applied during high signal artifacts. It is noted that all of the above signal replacement algorithms can be selectively applied in this manner based on the severity of the detected signal artifacts.

[0372] FIG. 16 is a graph that illustrates an embodiment wherein the signal replacement module comprises programming to selectively switch on and off a signal artifacts replacement algorithm responsive to detection of signal artifacts. The x-axis represents time in minutes; the first y-axis 160 represents sensor data output in counts. A raw data signal 161, which is illustrated as a dotted line, shows a data stream wherein some system noise can be detected; however signal artifacts 162 can be particularly seen in a portion thereof. The second y-axis 164 represents counter-electrode voltage in counts; counter electrode voltage data 165 is illustrated as a solid line. It is noted that a counter voltage drop to approximately zero in this example, which is one of numerous methods provided for detecting signal artifacts, detects signal artifacts 162. Accordingly, when the system detects the signal artifacts 162, an IIR-filter is selectively switched on in order to replace the signal artifact with an IIR-estimated glucose signal 166, which is illustrated as a heavy solid line. The IIR filter is switched off upon detection of negligible signal artifacts (e.g., counter electrode voltage increasing from about zero in this embodiment).

[0373] FIG. 17 is a graph that illustrates an embodiment wherein the signal artifacts replacement module comprises programming to selectively apply different signal artifacts replacement algorithms responsive to detection of signal artifacts. The x-axis represents time in minutes; the first y-axis 170 represents sensor data output in counts. A raw data signal 171, which is illustrated as a dotted line, shows a data stream wherein some system noise can be detected; however signal artifacts 172 can be particularly seen in a portion thereof. The second y-axis 174 represents counter-electrode voltage in counts; counter electrode voltage data 175 is illustrated as a solid line. It is noted that a counter voltage drop to approximately zero in this example, which is one of numerous methods provided for detecting signal artifacts, detects signal artifacts 172.

[0374] In this embodiment, an FIR filter is applied to the data stream during detection of negligible or no signal artifacts (e.g., during no noise to system noise in the data stream). Accordingly, normal signal noise (e.g., system

noise) can be filtered to replace the data stream with an FIR-filtered data signal 176, which is illustrated by a slightly heavy solid line. However, upon positive detection of signal artifacts (e.g., detected by approximately zero counter electrode voltage in this embodiment), the FIR filter is switched off and an IIR-filter is switched on in order to replace the signal artifacts with an IIR-filtered glucose signal 178, which is illustrated as a heavy solid line. The IIR filter is subsequently switched off and the FIR filter is switched back on upon detection of negligible signal artifacts (e.g., counter electrode voltage increasing from about zero in this embodiment).

[0375] In another embodiment, the signal replacement module comprises programming to selectively apply different parameters to a single signal artifacts replacement algorithm (e.g., IIR, Cone of Possibility Replacement Method, etc.). As an example, the parameters of an algorithm can be switched according to signal artifacts detection; in such an example, an IIR filter with a 30-minute cycle length can be used during times of no noise or system noise and a 60-minute cycle length can be used during signal artifacts. As another example, the severity of the signal artifacts can be defined as short and long; in such an example, an IIR filter with a 30-minute cycle length can be used during the short signal artifacts and a 60-minute cycle length can be used during long signal artifacts. As yet another example, the severity of the signal artifacts can be defined by a numerical representation; in such an example, the numerical representation can be used to calculate the parameters of the signal replacement algorithm (e.g., IIR, Cone of Possibility Replacement Method, and Reference Drift Method).

[0376] FIG. 18 is a flow chart that illustrates dynamic and intelligent estimation algorithm selection process 296 in an alternative embodiment.

[0377] At block 298, the dynamic and intelligent estimation algorithm selection process 296 obtains sensor data, which can be raw, smoothed, and/or otherwise processed. In some embodiments, data matching can use data from a raw data stream received from an analyte sensor, such as described at block 53. In some embodiments, data matching can use calibrated data.

[0378] At block 300, the dynamic and intelligent estimation algorithm selection process 296 includes selecting one or more algorithms from a plurality of algorithms that best fits the measured analyte values. In some embodiments, the estimative algorithm can be selected based on physiological parameters; for example, in an embodiment wherein the analyte sensor is a glucose sensor, a first order regression can be selected when the rate of change of the glucose concentration is high, indicating correlation with a straight line, while a second order regression can be selected when the rate of change of the glucose concentration is low, indicating correlation with a curved line. In some embodiments, a first order regression can be selected when the reference glucose data is within a certain threshold (for example, 100 to 200 mg/dL), indicating correlation with a straight line, while a second order regression can be selected when the reference glucose data is outside of a certain threshold (for example, 100 to 200 mg/dL), indicating correlation with a curved line because the likelihood of the glucose concentration turning around (for example, having a curvature) is greatest at high and low values.

[0379] Generally, algorithms that estimate analyte values from measured analyte values include any algorithm that fits the measured analyte values to a pattern, and/or extrapolates estimated values for another time period (for example, for a future time period or for a time period during which data needs to be replaced). In some embodiments, a polynomial regression (for example, first order, second order, third order, etc.) can be used to fit measured analyte values to a pattern, and then extrapolated. In some embodiments, autoregressive algorithms (for example, IIR filter) can be used to fit measured analyte values to a pattern, and then extrapolated. In some embodiments, measured analyte values can be filtered by frequency before projection (for example, by converting the analyte values with a Fourier transform, filtering out high frequency noise, and converting the frequency data back to time values by using an inverse Fourier transform); this data can then be projected forward (extrapolated) along lower frequencies. In some embodiments, measured analyte values can be represented with a Wavelet transform (for example filtering out specific noise depending on wavelet function), and then extrapolate forward. In some alternative embodiments, computational intelligence (for example, neural network-based mapping, fuzzy logic based pattern matching, genetic-algorithms based pattern matching, and the like) can be used to fit measured analyte values to a pattern, and/or extrapolate forward. In yet other alternative embodiments, time-series forecasting is employed using methods such as moving average (single or double), exponential smoothing (single, double, or triple), time series decomposition, growth curves, Box-Jenkins, and the like. The plurality of algorithms of the preferred embodiments can utilize any one or more of the above-described algorithms, or equivalents, in order to intelligently select estimative algorithms and thereby estimate analyte values.

[0380] In some embodiments, estimative algorithms further include parameters that consider external influences, such as insulin therapy, carbohydrate consumption, and the like. In one such example, these additional parameters can be user input via the user interface 47 or transmitted from an external device, such as an insulin pump, remote device, or other computer system. By including such external influences in addition to historical trend data (measured analyte values), analyte concentration changes can be better anticipated.

[0381] At block 302, the selected one or more algorithms are evaluated based on statistical, clinical, or physiological parameters. In some embodiments, running each algorithm on the data stream tests each of the one or more algorithms, and the algorithmic result with the best correlation to the measured analyte values is selected. In some embodiments, the pluralities of algorithms are each compared for best correlation with physiological parameters (for example, within known or expected rates of change, acceleration, concentration, etc). In some embodiments, the pluralities of algorithms are each compared for best fit within a clinical error grid (for example, within "A" region of Clarke Error Grid). Although first and second order algorithms are exemplified herein, any two or more algorithms such as described in more detail below could be programmed and selectively used based on a variety of conditions, including physiological, clinical, and/or statistical parameters.

[0382] At block 304, the algorithm(s) selected from the evaluation step is employed to estimate analyte values for a time period. Accordingly, analyte values are more dynamically and intelligently estimated to accommodate the dynamic nature of physiological data. Additional processes, for example applying physiological boundaries, evaluation of the estimation algorithms after employing the algorithms, evaluating a variation of estimated analyte values, measuring and comparing analyte values, and the like (e.g., such as described in co-pending U.S. Published Patent Application 2005-0203360 to Brauker et al.) can be applied to the dynamic and intelligent estimative algorithms described herein

[0383] FIG. 19 is a graph that illustrates dynamic and intelligent estimation algorithm selection applied to a data stream in one embodiment showing first order estimation, second order estimation, and the measured glucose values for the time period, wherein the second order estimation shows a better correlation to the measured glucose data than the first order estimation. The x-axis represents time in minutes. The y-axis represents glucose concentration in mg/dL.

[0384] In the data of FIG. 19, measured (calibrated) sensor glucose data 306 was obtained up to time  $t=0$ . At  $t=0$ , a first order regression 308 was performed on the measured data 306 to estimate the upcoming 15-minute time period. A second order regression 310 was also performed on the data to estimate the upcoming 15-minute time period. The intelligent estimation of the preferred embodiments, such as described in more detail below, chose the second order regression 310 as the preferred algorithm for estimation based on programmed conditions (at  $t=0$ ). The graph of FIG. 19 further shows the measured glucose values 312 from  $t=0$  to  $t=15$  to illustrate that second order regression 310 does in fact more accurately correlate with the measured glucose data 312 than first order regression 308 from  $t=0$  to  $t=15$ .

[0385] In the example of FIG. 19, the dynamic and intelligent estimation algorithm selection determined that the second order regression 310 was the preferred algorithm for estimation at  $t=0$  based on conditions. A first condition was based on a set threshold that considers second order regression a better fit when measured glucose values are above 200 mg/dL and trending upwardly. A second condition verifies that the curvature of the second order regression line appropriately shows a deceleration above 200 mg/dL. Although two specific examples of conditions are described herein, dynamic and intelligent estimation can have as many or as few conditions programmed therein as can be imagined or contrived. Some additional examples of conditions for selecting from a plurality of algorithms are listed above, however the scope of this aspect of dynamic and intelligent estimation includes any conditional statements that can be programmed and applied to any algorithms that can be implemented for estimation.

[0386] FIG. 20 is a flow chart that illustrates the process 330 of dynamic and intelligent estimation and evaluation of analyte values in one embodiment, wherein the estimation algorithms are continuously, periodically, or intermittently evaluated based on statistical, clinical, or physiological parameters to maintain accuracy of estimation.



[0387] At block 332, the dynamic and intelligent estimation and evaluation process 130 obtains sensor data, which can be raw, smoothed, calibrated and/or otherwise processed.

[0388] At block 334, the dynamic and intelligent estimation and evaluation process 330 estimates one or more analyte values using one or more estimation algorithms. In some embodiments, this analyte value estimation uses conventional projection using first or second order regression, for example. In some embodiments, dynamically and intelligently selecting of one or more algorithms from a plurality of algorithms, dynamically and intelligently estimating analyte values within physiological boundaries, evaluating a variation of estimated analyte values, measuring and comparing analyte values, and the like (e.g., such as described in U.S. Publication No. US-2005-0203360-A1) can be applied to the dynamic and intelligent estimation and evaluation process described herein.

[0389] The estimative algorithms described elsewhere herein consider mathematical equations, for example, which may or may not be sufficient to accurately estimate analyte values in some circumstances due to the dynamic nature of mammalian behavior. For example, in a circumstance where a patient's glucose concentration is trending upwardly at a constant rate of change (for example, 120 mg/dL at 2 mg/dL/min), an expected physiological pattern would likely estimate a continued increase at substantially the same rate of change over the upcoming approximately 40 minutes, which would fall within physiological boundaries. However, if a person with diabetes were to engage in heavy aerobic exercise, which may not be known by the estimative algorithm, a slowing of the upward trend, and possibly a change to a downward trend can possibly result, leading to inaccuracies in the estimated analyte values. Numerous such circumstances can occur in the lifestyle of a person with diabetes. However, although analyte values can sometimes be estimated under "normal" circumstances, other circumstances exist that are not "normal" or "expected" and can result in estimative algorithms that produce apparently erroneous results, for example, if they are based solely on mathematical calculations and/or physiological patterns. Accordingly, evaluation of the estimative algorithms can be performed to ensure the accuracy or quantify a measure of confidence in the estimative algorithms.

[0390] At block 336, the dynamic and intelligent estimation and evaluation process 330 evaluates the estimation algorithms employed at block 334 to evaluate a "goodness" of the estimated analyte values. The evaluation process performs an evaluation of the measured analyte data with the corresponding estimated analyte data (e.g., by performing the algorithm on the data stream and comparing the measured with the corresponding analyte data for a time period). In some embodiments, evaluation can be performed continually or continuously so that the dynamic and intelligent algorithms are continuously adapting to the changing physiological analyte data. In some embodiments, the evaluation can be performed periodically so that the dynamic and intelligent algorithms are periodically and systematically adapting to the changing physiological analyte data. In some embodiments, evaluation can be performed intermittently, for example when an estimative algorithm is initiated or when other such triggers occur, so that the dynamic and

intelligent algorithms can be evaluated when new or updated data or algorithms are being processed.

[0391] This evaluation process 330 uses any known evaluation method, for example based on statistical, clinical, or physiological standards. One example of statistical evaluation is provided below with reference to FIG. 21; however other methods are also possible. In some embodiments, the evaluation process 330 determines a correlation coefficient of regression. In some embodiments wherein the sensor is a glucose sensor, the evaluation process 330 determines if the selected estimative algorithm shows that analyte values fall with the "A" and "B" regions of the Clarke Error Grid. Other parameters or methods for evaluation are considered within the scope of the preferred embodiments. In some embodiments, the evaluation process 330 includes performing a curvature formula to determine fiducial information about the curvature, which results in an evaluation of the amount of noise on the signal.

[0392] In some embodiments, the evaluation process 330 calculates physiological boundaries to evaluate whether the estimated analyte values fall within known physiological constraints. In this embodiment, the estimative algorithm(s) are evaluated to ensure that they do not allow estimated analyte values to fall outside of physiological boundaries, some examples of which are described in more detail elsewhere herein, and in co-pending U.S. Published Patent Application 2005-0203360 to Brauker et al., for example. In some alternative embodiments, clinical or statistical parameters can be used in a similar manner to bound estimated analyte values.

[0393] If the result of the evaluation is satisfactory (for example, 10% average deviation, correlation coefficient above 0.79, all estimated analyte values within A or B region of the Clarke Error Grid, all estimated analyte values within physiological boundaries, and the like), the processing continues to the next step, using the selected estimative algorithm. However, if the result of the evaluation is unsatisfactory, the process can start the algorithm selection process again, optionally considering additional information, or the processor can determine that estimation is not appropriate for a certain time period. In one alternative embodiment, a signal noise measurement can be evaluated, and if the signal to noise ratio is unacceptable, the processor can modify its estimative algorithm or other action that can help compensate for signal noise (e.g., signal artifacts, such as described elsewhere herein).

[0394] FIG. 21 is a graph that illustrates an evaluation of the selected estimative algorithm in one embodiment, wherein a correlation is measured to determine a deviation of the measured glucose data with the selected estimative algorithm, if any. The x-axis represents time in minutes. The y-axis represents glucose concentration in mg/dL. Measured glucose values 340 are shown for about 90 minutes up to  $t=0$ . At  $t=0$ , the selected algorithm is performed on 40 minutes of the measured glucose values 340 up to  $t=0$ , which is represented by a regression line 342 in this embodiment. A data association function is used to determine a goodness of fit of the estimative algorithm on the measured glucose data 340; namely, the estimative algorithm is performed retrospectively on the measured glucose data 340, and is hereinafter referred to as retrospectively estimated glucose data 342 (e.g., estimation prior to  $t=0$ ), after which a

correlation (or deviation) with the measured glucose data is determined. In this example, the goodness of fit shows a mean absolute relative difference (MARD) of 3.3% between the measured glucose data **340** and the retrospectively estimated glucose data **342**. While not wishing to be bound to theory, it is believed that this correlation of the measured glucose data **340** to the retrospectively estimated glucose data **342** can be indicative of the correlation of future estimated glucose data to the measured glucose data for that estimated time period.

[**0395**] Reference is now made to FIG. **22**, which is a flow chart that illustrates the process **450** of analyzing a variation of estimated future analyte value possibilities in one embodiment. This embodiment takes into consideration that analyte values are subject to a variety of external influences, which can cause the measured analyte values to alter from the estimated analyte values as the time period that was estimated passes. External influences include, but are not limited to, exercise, sickness, consumption of food and alcohol, injections of insulin, other medications, and the like. For a person with diabetes, for example, even when estimation does not accurately predict the upcoming measured analyte values, the estimated analyte values can be valuable to a patient in treatment and in fact can even alter the estimated path by encouraging proactive patient behavior that can cause the patient to avoid the estimated clinical risk. In other words, the deviation of measured analyte values from their corresponding estimated analyte values may not be an "error" in the estimative algorithm, and is in fact one of the benefits of the continuous analyte sensor of the preferred embodiments, namely encouraging patient behavior modification and thereby improving patient health through minimizing clinically risky analyte values. Proactive behavior modification (for example, therapies such as insulin injections, carbohydrate consumption, exercise, and the like) can cause the patient's measured glucose to change from the estimated path, and analyzing a variation that can be associated with the estimated analyte values can encompass many of these changes. Therefore, in addition to estimated analyte values, a variation can be calculated or estimated based on statistical, clinical, and/or physiological parameters that provides a range of values in which the estimated analyte values can fall.

[**0396**] At block **452**, the variation of possible estimated analyte values analysis process **450** obtains sensor data, which can be raw, smoothed, calibrated and/or otherwise processed.

[**0397**] At block **454**, the variation of possible estimated analyte values analysis process **450** estimates one or more analyte values using one or more estimation algorithms. In some embodiments, this analyte values estimation uses conventional projection using first or second order regression, for example. In some embodiments, dynamically and intelligently selecting of one or more algorithms from a plurality of algorithms, dynamically and intelligently estimating analyte values within physiological boundaries, dynamic and intelligent estimation and evaluation of estimated analyte values, measuring and comparing analyte values (e.g., such as described in U.S. Publication No. US-2005-0203360-A1), and the like can be applied to the dynamic and intelligent estimation and evaluation process described herein.

[**0398**] At block **456**, the variation of possible estimated analyte values evaluation process **450** analyzes a variation of the estimated analyte data. Particularly, a statistical, clinical, and/or physiological variation of estimated analyte values can be calculated when applying the estimative algorithms and/or can be calculated at regular intervals to dynamically change as the measured analyte values are obtained. In general, analysis of trends and their variation allows the estimation of the preferred embodiments to dynamically and intelligently anticipate upcoming conditions, by considering internal and external influences that can affect analyte concentration.

[**0399**] In some embodiments, physiological boundaries for analytes in mammals can be used to set the boundaries of variation. For example, known physiological boundaries of glucose in humans are discussed in detail with reference to U.S. Publication No. US-2005-0203360-A1, however any physiological parameters for any measured analyte can be implemented here to provide this variation of physiologically feasible analyte values.

[**0400**] In some embodiments, statistical variation can be used to determine a variation of possible analyte values. Statistical variation can be any known divergence or change from a point, line, or set of data based on statistical information. Statistical information includes patterns or data analysis resulting from experiments, published or unpublished, for example. In some embodiments, statistical information can include normal patterns that have been measured statistically in studies of analyte concentrations in mammals, for example. In some embodiments, statistical information can include errors observed and measured statistically in studies of analyte concentrations in mammals, for example. In some embodiments, statistical information can include predetermined statistical standards, for example, deviation less than or equal to 5% on the analyte value. In some embodiments, statistical variation can be a measured or otherwise known signal noise level.

[**0401**] In some embodiments, a variation is determined based on the fact that the conventional blood glucose meters are known to have up to a  $\pm 20\%$  error in glucose values (namely, on average in the hands of a patient). For example, gross errors in glucose readings are known to occur due to patient error in self-administration of the blood glucose test. In one such example, if the user has traces of sugar on his/her finger while obtaining a blood sample for a glucose concentration test, then the measured glucose value will likely be much higher than the measured glucose value in the blood. Additionally, it is known that self-monitored blood glucose tests (for example, test strips) are occasionally subject to manufacturing error. In view of this statistical information, in an embodiment wherein a continuous glucose sensor relies upon a conventional blood glucose meter for calibration, this  $\pm 20\%$  error should be considered because of the potential for translated effect on the calibrated sensor analyte data. Accordingly, this exemplary embodiment would provide for a  $\pm 20\%$  variation of estimated glucose values based on the above-described statistical information.

[**0402**] In some embodiments, a variation of estimated analyte values can be analyzed based on individual physiological patterns. Physiological patterns are affected by a combination of at least biological mechanisms, physiologi-

cal boundaries, and external influences such as exercise, sickness, consumption of food and alcohol, injections of insulin, other medications, and the like. Advantageously, pattern recognition can be used with continuous analyte sensors to characterize an individual's physiology; for example the metabolism of a person with diabetes can be individually characterized, which has been difficult to quantify with conventional glucose sensing mechanisms due to the unique nature of an individual's metabolism. Additionally, this information can be advantageously linked with external influences (for example, patient behavior) to better understand the nature of individual human physiology, which can be helpful in controlling the basal rate in a person with diabetes, for example.

[0403] While not wishing to be bound to theory, it is believed that monitoring of individual historical physiological analyte data can be used to recognize patterns that can be used to estimate analyte values, or ranges of values, in a mammal. For example, measured analyte data for a patient can show certain peaks of glucose levels during a specific time of day, "normal" AM and PM eating behaviors (for example, that follow a pattern), weekday versus weekend glucose patterns, individual maximum rate of change, and the like, that can be quantified using patient-dependent pattern recognition algorithms, for example. Pattern recognition algorithms that can be used in this embodiment include, but are not limited to, stochastic nonlinear time-series analysis, exponential (non-linear) autoregressive model, process feedback nonlinear autoregressive (PFNAR) model, neural networks, and the like.

[0404] Accordingly, statistically calculated patterns can provide information useful in analyzing a variation of estimated analyte values for a patient that includes consideration of the patient's normal physiological patterns. Pattern recognition enables the algorithmic analysis of analyte data to be customized to a user, which is useful when analyte information is variable with each individual user, such as has been seen in glucose in humans, for example.

[0405] In some embodiments, a variation of estimated analyte values is on clinical risk analysis. Estimated analyte values can have higher clinical risk in certain ranges of analyte values, for example analyte values that are in a clinically risky zone or analyte values that are changing at a clinically risky rate of change. When a measured analyte value or an estimated analyte value shows existing or approaching clinical risk, it can be important to analyze the variation of estimated analyte values in view of the clinical risk to the patient. For example, in an effort to aid a person with diabetes in avoiding clinically risky hyper- or hypoglycemia, a variation can be weighted toward the clinically risk zone, which can be used to emphasize the pending danger to the patient, doctor, or care taker, for example. As another example, the variation of measured or estimated analyte values can be based on values that fall within the "A" and/or "B" regions of an error grid Analysis Method.

[0406] In case of variation analysis based on clinical risk, the estimated analyte values are weighted in view of pending clinical risk. For example, if estimated glucose values show a trend toward hypoglycemia at a certain rate of change, a variation of possible trends toward hypoglycemia are weighted to show how quickly the glucose concentration could reach 40 mg/dL, for example. As another example, if

estimated glucose values show a trend toward hyperglycemia at a certain acceleration, a variation of possible trends toward hyperglycemia are weighted to show how quickly the glucose concentration could reach 200 mg/dL, for example.

[0407] In some embodiments, when a variation of the estimated analyte values shows higher clinical risk as a possible path within that variation analysis as compared to the estimated analyte path, the estimated analyte values can be adjusted to show the analyte values with the most clinical risk to a patient. While not wishing to be bound by theory, adjusting the estimated analyte values for the highest variation of clinical risk exploits the belief that by showing the patient the "worst case scenario," the patient is more likely to address the clinical risk and make timely behavioral and therapeutic modifications and/or decisions that will slow or reverse the approaching clinical risk.

[0408] At block 458, the variation of possible estimated analyte values evaluation process 150 provides output based on the variation analysis. In some embodiments, the result of this variation analysis provides a "zone" of possible values, which can be displayed to the user, considered in data analysis, and/or used in evaluating of performance of the estimation, for example.

[0409] FIG. 23 is a graph that illustrates variation analysis of estimated glucose values in one embodiment, wherein a variation of the estimated glucose values is analyzed and determined based on known physiological parameters. The x-axis represents time in minutes. The y-axis represents glucose concentration in mg/dL. In this embodiment, the known maximum rate of change and acceleration of glucose in humans are used to provide the variation about the estimated glucose path.

[0410] The measured glucose values 460 are shown for about 90 minutes up to  $t=0$ . At  $t=0$ , intelligent and dynamic estimation of the preferred embodiments is performed to obtain estimated glucose values 462. A variation of estimated glucose values is then determined based on physiological parameters, including an upper limit 464 and a lower limit 466 of variation defined by known physiological parameters, including rate of change and acceleration of glucose concentration in humans.

[0411] FIG. 24 is a graph that illustrates variation of estimated analyte values in another embodiment, wherein the variation is based on statistical parameters. The x-axis represents time in minutes and the y-axis represents glucose concentration in mg/dL. The measured glucose values 470 are shown for about 160 minutes up to  $t=0$ . At  $t=0$ , intelligent and dynamic estimation of the preferred embodiments is employed to obtain estimated glucose values 472. A variation is defined by upper and lower limits 474 that were determined using 95% confidence intervals. Bremer, T.; Gough, D. A. "Is blood glucose predictable from previous values? A solicitation for data." *Diabetes* 1999, 48, 445-451, which is incorporated by reference herein in its entirety, teaches a method of determining a confidence interval in one embodiment.

[0412] Although some embodiments have been described for a glucose sensor, any measured analyte pattern, data analysis resulting from an experiment, or otherwise known statistical information, whether official or unofficial, pub-

lished or unpublished, proven or anecdotal, and the like, can be used to provide the statistical variation described herein.

[0413] FIG. 25 is a flow chart that illustrates the process 480 of estimating, measuring, and comparing analyte values in one embodiment.

[0414] At block 482, the estimating, measuring, and comparing analyte values process 480 obtains sensor data, which can be raw, smoothed, calibrated and/or otherwise processed.

[0415] At block 484, the estimating, measuring, and comparing analyte values process 480 estimates one or more analyte values for a time period. In some embodiments, this analyte values estimation uses conventional projection using first or second order regression, for example. In some embodiments, dynamically and intelligently selecting of one or more algorithms from a plurality of algorithms, dynamically and intelligently estimating analyte values within physiological boundaries), dynamic and intelligent estimation and evaluation of estimated analyte values, variation analysis (e.g., such as described in co-pending U.S. Published Patent Application 2005-0203360 to Brauker et al.), and the like can be applied to the process described herein.

[0416] At block 486, the estimating, measuring, and comparing analyte values process 480 obtains sensor data for the time period for which the estimated analyte values were calculated at block 484. In some embodiments, the measured analyte data can be raw, smoothed, calibrated, and/or otherwise processed.

[0417] At block 488, the estimating, measuring, and comparing analyte values process 480 compares the estimated analyte data to the measured analyte data for that estimated time period. In general, it can be useful to compare the estimated analyte data to the measured analyte data for that estimated time period after estimation of analyte values. This comparison can be performed continuously, namely, at regular intervals as data streams are processed into measured analyte values. Alternatively, this comparison can be performed based on events, such as during estimation of measured analyte values, selection of an estimative algorithm, evaluation of estimative algorithms, variation analysis of estimated analyte values, calibration and transformation of sensor analyte data, and the like.

[0418] One embodiment is shown in FIG. 26, wherein MARD is used to determine a correlation (or deviation), if any, between the estimated and measured data sets. In other embodiments, other methods, such as linear regression, non-linear mapping/regression, rank (for example, non-parametric) correlation, least mean square fit, mean absolute deviation (MAD), and the like, can be used to compare the estimated analyte data to the measured analyte data to determine a correlation (or deviation), if any.

[0419] In one embodiment, wherein estimation is used in outlier detection and/or in matching data pairs for a continuous glucose sensor (see FIGS. 5 and 6), the estimated glucose data can be plotted against reference glucose data on a clinical error grid (for example, Clarke Error Grid or rate grid) and then compared to the measured glucose data for that estimated time period plotted against the same reference analyte data on the same clinical error grid. In alternative embodiments, other clinical error analysis methods can be used, such as Consensus Error Grid, rate of change calcu-

lation, consensus grid, and standard clinical acceptance tests, for example. The deviation can be quantified by percent deviation, or can be classified as pass/fail, for example.

[0420] In some embodiments, the results of the comparison provide a quantitative deviation value, which can be used to provide a statistical variation; for example, if the % deviation is calculated as 8%, then the statistical variation such as described with reference to FIG. 22 can be updated with a +/-8% variation. In some alternative embodiments, the results of the comparison can be used to turn on/off the estimative algorithms, estimative output, and the like. In general, the comparison produces a confidence interval (for example, +/-8% of estimated values) which can be used in data analysis, output of data to a user, and the like.

[0421] A resulting deviation from this comparison between estimated and corresponding measured analyte values may or may not imply error in the estimative algorithms. While not wishing to be bound by theory, it is believed that the deviation between estimated and corresponding measured analyte values is due, at least in part, to behavioral changes by a patient, who observes estimated analyte values and determines to change the present trend of analyte values by behavioral and/or therapeutic changes (for example, medication, carbohydrate consumption, exercise, rest, and the like). Accordingly, the deviation can also be used to illustrate positive changes resulting from the educational aspect of providing estimated analyte values to the user, for example.

[0422] FIG. 26 is a graph that illustrates comparison of estimated analyte values in one embodiment, wherein previously estimated analyte values are compared to time corresponding measured analyte values to determine a correlation (or deviation), if any. The x-axis represents time in minutes. The y-axis represents glucose concentration in mg/dL. The measured glucose values 492 are shown for about 105 minutes up to t=15. The estimated analyte values 494, which were estimated at t=0 for 15 minutes, are shown superimposed over the measured analyte values 492. Using a 3-point MARD for t=0 to t=15, the estimated analyte values 494 can be compared with the measured analyte values 492 to determine a 0.55% average deviation.

[0423] FIG. 27 provides a flow chart 520 that illustrates the evaluation of reference and/or sensor data for statistical, clinical, and/or physiological acceptability in one embodiment. Although some acceptability tests are disclosed herein, any known statistical, clinical, physiological standards and methodologies can be applied to evaluate the acceptability of reference and sensor analyte data.

[0424] One cause for discrepancies in reference and sensor data is a sensitivity drift that can occur over time, when a sensor is inserted into a host and cellular invasion of the sensor begins to block transport of the analyte to the sensor, for example. Therefore, it can be advantageous to validate the acceptability of converted sensor data against reference analyte data, to determine if a drift of sensitivity has occurred and whether the calibration should be updated.

[0425] In one embodiment, the reference analyte data is evaluated with respect to substantially time corresponding converted sensor data to determine the acceptability of the matched pair. For example, clinical acceptability considers a

deviation between time corresponding analyte measurements (for example, data from a glucose sensor and data from a reference glucose monitor) and the risk (for example, to the decision making of a person with diabetes) associated with that deviation based on the glucose value indicated by the sensor and/or reference data. Evaluating the clinical acceptability of reference and sensor analyte data, and controlling the user interface dependent thereon, can minimize clinical risk. Preferably, the receiver evaluates clinical acceptability each time reference data is obtained.

[0426] After initial calibration, such as is described in more detail with reference to FIG. 5, the sensor data receiving module receives substantially continuous sensor data (e.g., a data stream) via a receiver and converts that data into estimated analyte values. As used herein, the term “substantially continuous” is a broad term and is used in its ordinary sense, without limitation, to refer to a data stream of individual measurements taken at time intervals (e.g., time-spaced) ranging from fractions of a second up to, e.g., 1, 2, or 5 minutes or more. As sensor data is continuously converted, it can be occasionally recalibrated in response to changes in sensor sensitivity (drift), for example. Initial calibration and re-calibration of the sensor require a reference analyte value. Accordingly, the receiver can receive reference analyte data at any time for appropriate processing.

[0427] At block 522, the reference data receiving module, also referred to as the reference input module, receives reference analyte data from a reference analyte monitor. In one embodiment, the reference data comprises one analyte value obtained from a reference monitor. In some alternative embodiments however, the reference data includes a set of analyte values entered by a user into the interface and averaged by known methods, such as are described elsewhere herein. In some alternative embodiments, the reference data comprises a plurality of analyte values obtained from another continuous analyte sensor.

[0428] The reference data can be pre-screened according to environmental and physiological issues, such as time of day, oxygen concentration, postural effects, and patient-entered environmental data. In one exemplary embodiment, wherein the sensor comprises an implantable glucose sensor, an oxygen sensor within the glucose sensor is used to determine if sufficient oxygen is being provided to successfully complete the necessary enzyme and electrochemical reactions for accurate glucose sensing. In another exemplary embodiment, the patient is prompted to enter data into the user interface, such as meal times and/or amount of exercise, which can be used to determine likelihood of acceptable reference data. In yet another exemplary embodiment, the reference data is matched with time-corresponding sensor data, which is then evaluated on a modified clinical error grid to determine its clinical acceptability.

[0429] Some evaluation data, such as described in the paragraph above, can be used to evaluate an optimum time for reference analyte measurement. Correspondingly, the user interface can then prompt the user to provide a reference data point for calibration within a given time period. Consequently, because the receiver proactively prompts the user during optimum calibration times, the likelihood of error due to environmental and physiological limitations can decrease and consistency and acceptability of the calibration can increase.

[0430] At block 524, the evaluation module, also referred to as acceptability module, evaluates newly received reference data. In one embodiment, the evaluation module evaluates the clinical acceptability of newly received reference data and time corresponding converted sensor data (new matched data pair). In one embodiment, a clinical acceptability evaluation module 524 matches the reference data with a substantially time corresponding converted sensor value, and determines the Clarke Error Grid coordinates. In this embodiment, matched pairs that fall within the A and B regions of the Clarke Error Grid are considered clinically acceptable, while matched pairs that fall within the C, D, and E regions of the Clarke Error Grid are not considered clinically acceptable.

[0431] A variety of other known methods of evaluating clinical acceptability can be utilized. In one alternative embodiment, the Consensus Grid is used to evaluate the clinical acceptability of reference and sensor data. In another alternative embodiment, a mean absolute difference calculation can be used to evaluate the clinical acceptability of the reference data. In another alternative embodiment, the clinical acceptability can be evaluated using any relevant clinical acceptability test, such as a known grid (e.g., Clarke Error or Consensus), and additional parameters, such as time of day and/or the increase or decreasing trend of the analyte concentration. In another alternative embodiment, a rate of change calculation can be used to evaluate clinical acceptability. In yet another alternative embodiment, wherein the received reference data is in substantially real time, the conversion function could be used to predict an estimated glucose value at a time corresponding to the time stamp of the reference analyte value (this can be required due to a time lag of the sensor data such as described elsewhere herein). Accordingly, a threshold can be set for the predicted estimated glucose value and the reference analyte value disparity, if any. In some alternative embodiments, the reference data is evaluated for physiological and/or statistical acceptability as described in more detail elsewhere herein.

[0432] At decision block 526, results of the evaluation are assessed. If acceptability is determined, then processing continues to block 528 to re-calculate the conversion function using the new matched data pair in the calibration set.

[0433] At block 528, the conversion function module re-creates the conversion function using the new matched data pair associated with the newly received reference data. In one embodiment, the conversion function module adds the newly received reference data (e.g., including the matched sensor data) into the calibration set, and recalculates the conversion function accordingly. In alternative embodiments, the conversion function module displaces the oldest, and/or least concordant matched data pair from the calibration set, and recalculates the conversion function accordingly.

[0434] At block 530, the sensor data transformation module uses the new conversion function (from block 528) to continually (or intermittently) convert sensor data into estimated analyte values, also referred to as calibrated data, or converted sensor data, such as is described in more detail above.

[0435] At block 532, an output module provides output to the user via the user interface. The output is representative

of the estimated analyte value, which is determined by converting the sensor data into a meaningful analyte value. User output can be in the form of a numeric estimated analyte value, an indication of directional trend of analyte concentration, and/or a graphical representation of the estimated analyte data over a period of time, for example. Other representations of the estimated analyte values are also possible, for example audio and tactile.

[0436] If, however, acceptability is determined at decision block 526 as negative (unacceptable), then the processing progresses to block 534 to adjust the calibration set. In one embodiment of a calibration set adjustment, the conversion function module removes one or more oldest matched data pair(s) and recalculates the conversion function accordingly. In an alternative embodiment, the conversion function module removes the least concordant matched data pair from the calibration set, and recalculates the conversion function accordingly.

[0437] At block 536, the conversion function module re-creates the conversion function using the adjusted calibration set. While not wishing to be bound by theory, it is believed that removing the least concordant and/or oldest matched data pair(s) from the calibration set can reduce or eliminate the effects of sensor sensitivity drift over time, adjusting the conversion function to better represent the current sensitivity of the sensor.

[0438] At block 524, the evaluation module re-evaluates the acceptability of newly received reference data with time corresponding converted sensor data that has been converted using the new conversion function (block 536). The flow continues to decision block 538 to assess the results of the evaluation, such as described with reference to decision block 526, above. If acceptability is determined, then processing continues to block 530 to convert sensor data using the new conversion function and continuously display calibrated sensor data on the user interface.

[0439] If, however, acceptability is determined at decision block 526 as negative, then the processing loops back to block 534 to adjust the calibration set once again. This process can continue until the calibration set is no longer sufficient for calibration, for example, when the calibration set includes only one or no matched data pairs with which to create a conversion function. In this situation, the system can return to the initial calibration or start-up mode, which is described in more detail with reference to FIGS. 16 and 19, for example. Alternatively, the process can continue until inappropriate matched data pairs have been sufficiently purged and acceptability is positively determined.

[0440] In alternative embodiments, the acceptability is determined by a quality evaluation, for example, calibration quality can be evaluated by determining the statistical association of data that forms the calibration set, which determines the confidence associated with the conversion function used in calibration and conversion of raw sensor data into estimated analyte values. See, e.g., U.S. Publication No. US-2005-0027463-A1.

[0441] Alternatively, each matched data pair can be evaluated based on clinical or statistical acceptability such as described above; however, when a matched data pair does not pass the evaluation criteria, the system can be configured to ask for another matched data pair from the user. In this

way, a secondary check can be used to determine whether the error is more likely due to the reference glucose value or to the sensor value. If the second reference glucose value substantially correlates to the first reference glucose value, it can be presumed that the reference glucose value is more accurate and the sensor values are errant. Some reasons for errancy of the sensor values include a shift in the baseline of the signal or noise on the signal due to low oxygen, for example. In such cases, the system can be configured to re-initiate calibration using the secondary reference glucose value. If, however, the reference glucose values do not substantially correlate, it can be presumed that the sensor glucose values are more accurate and the reference glucose values eliminated from the algorithm.

[0442] FIG. 28 is a flow chart 550 that illustrates the evaluation of calibrated sensor data for aberrant values in one embodiment. Although sensor data are typically accurate and reliable, it can be advantageous to perform a self-diagnostic check of the calibrated sensor data prior to displaying the analyte data on the user interface.

[0443] One reason for anomalies in calibrated sensor data includes transient events, such as local ischemia at the implant site, which can temporarily cause erroneous readings caused by insufficient oxygen to react with the analyte. Accordingly, the flow chart 550 illustrates one self-diagnostic check that can be used to catch erroneous data before displaying it to the user.

[0444] At block 552, a sensor data receiving module, also referred to as the sensor data module, receives new sensor data from the sensor.

[0445] At block 554, the sensor data transformation module continuously (or intermittently) converts new sensor data into estimated analyte values, also referred to as calibrated data.

[0446] At block 556, a self-diagnostic module compares the new calibrated sensor data with previous calibrated sensor data, for example, the most recent calibrated sensor data value. In comparing the new and previous sensor data, a variety of parameters can be evaluated. In one embodiment, the rate of change and/or acceleration (or deceleration) of change of various analytes, which have known physiological limits within the body, and sensor data can be evaluated accordingly. For example, a limit can be set to determine if the new sensor data is within a physiologically feasible range, indicated by a rate of change from the previous data that is within known physiological (and/or statistical) limits. Similarly, any algorithm that predicts a future value of an analyte can be used to predict and then compare an actual value to a time corresponding predicted value to determine if the actual value falls within a statistically and/or clinically acceptable range based on the predictive algorithm, for example. In certain embodiments, identifying a disparity between predicted and measured analyte data can be used to identify a shift in signal baseline responsive to an evaluated difference between the predicted data and time-corresponding measured data. In some alternative embodiments, a shift in signal baseline and/or sensitivity can be determined by monitoring a change in the conversion function; namely, when a conversion function is re-calculated using the equation  $y=mx+b$ , a change in the values of  $m$  (sensitivity) or  $b$  (baseline) above a pre-selected "normal" threshold, can be used to trigger a fail-safe or further diagnostic evaluation.

[0447] Although the above-described self-diagnostics are generally employed with calibrated sensor data, some alternative embodiments are contemplated that check for aberrancy of consecutive sensor values prior to sensor calibration, for example, on the raw data stream and/or after filtering of the raw data stream. In certain embodiments, an intermittent or continuous signal-to-noise measurement can be evaluated to determine aberrancy of sensor data responsive to a signal-to-noise ratio above a set threshold. In certain embodiments, signal residuals (e.g. by comparing raw and filtered data) can be intermittently or continuously analyzed for noise above a set threshold. In certain embodiments, pattern recognition can be used to identify noise associated with physiological conditions, such as low oxygen or other known signal aberrancies. Accordingly, in these embodiments, the system can be configured, in response to aberrancies in the data stream, to trigger signal estimation, adaptively filter the data stream according to the aberrancy, and the like, as described in more detail herein.

[0448] In another embodiment, reference analyte values are processed to determine a level of confidence, wherein reference analyte values are compared to their time-corresponding calibrated sensor values and evaluated for clinical or statistical accuracy. In yet another alternative embodiment, new and previous reference analyte data are compared in place of or in addition to sensor data. In general, there exist known patterns and limitations of analyte values that can be used to diagnose certain anomalies in raw or calibrated sensor and/or reference analyte data.

[0449] At decision block 558, the system determines whether the comparison returned aberrant values. In one embodiment, the slope (rate of change) between the new and previous sensor data is evaluated, wherein values greater than  $\pm 10$ , 15, 20, 25, or 30% or more change and/or  $\pm 2$ , 3, 4, 5, 6 or more mg/dL/min, more preferably  $\pm 4$  mg/dL/min, rate of change are considered aberrant. In certain embodiments, other known physiological parameters can be used to determine aberrant values. However, a variety of comparisons and limitations can be set.

[0450] At block 560, if the values are not found to be aberrant, the sensor data transformation module continuously (or intermittently) converts received new sensor data into estimated analyte values, also referred to as calibrated data;

[0451] At block 562, if the values are found to be aberrant, the system goes into a suspended mode, also referred to as fail-safe mode in some embodiments, which is described in more detail below with reference to FIG. 29. In general, suspended mode suspends display of calibrated sensor data and/or insertion of matched data pairs into the calibration set. Preferably, the system remains in suspended mode until received sensor data is not found to be aberrant. In certain embodiments, a time limit or threshold for suspension is set, after which system and/or user interaction can be required, for example, requesting additional reference analyte data, replacement of the electronics unit, and/or reset.

[0452] In some alternative embodiments, in response to a positive determination of aberrant value(s), the system can be configured to estimate one or more glucose values for the time period during which aberrant values exist. Signal estimation generally refers to filtering, data smoothing, augmenting, projecting, and/or other methods for estimating

glucose values based on historical data, for example. In one implementation of signal estimation, physiologically feasible values are calculated based on the most recent glucose data, and the aberrant values are replaced with the closest physiologically feasible glucose values. See also U.S. Publication No. US-2005-0027463-A1.

[0453] FIG. 29 provides a flow chart 580 that illustrates a self-diagnostic of sensor data in one embodiment. Although reference analyte values can be useful for checking and calibrating sensor data, self-diagnostic capabilities of the sensor provide for a fail-safe for displaying sensor data with confidence and enable minimal user interaction (for example, requiring reference analyte values only as needed).

[0454] At block 582, a sensor data receiving module, also referred to as the sensor data module, receives new sensor data from the sensor.

[0455] At block 584, the sensor data transformation module continuously (or intermittently) converts received new sensor data into estimated analyte values, also referred to as calibrated data.

[0456] At block 586, a self-diagnostics module, also referred to as a fail-safe module, performs one or more calculations to determine the accuracy, reliability, and/or clinical acceptability of the sensor data. Some examples of the self-diagnostics module are described above, with reference to block 556. The self-diagnostics module can be further configured to run periodically (e.g., intermittently or in response to a trigger), for example, on raw data, filtered data, calibrated data, predicted data, and the like.

[0457] In certain embodiments, the self-diagnostics module evaluates an amount of time since sensor insertion into the host, wherein a threshold is set for the sensor's usable life, after which time period the sensor is considered to be unreliable. In certain embodiments, the self-diagnostics module counts the number of times a failure or reset is required (for example, how many times the system is forced into suspended or start-up mode), wherein a count threshold is set for a predetermined time period, above which the system is considered to be unreliable. In certain embodiments, the self-diagnostics module compares newly received calibrated sensor data with previously calibrated sensor data for aberrant values, such as is described in more detail elsewhere herein. In certain embodiments, the self-diagnostics module evaluates clinical acceptability, such as is described in more detail with reference to FIG. 28, above. In certain embodiments, diagnostics, such as are described in U.S. Publication No. US-2005-0161346-A1 and U.S. Publication No. US-2005-0143635-A1, can be incorporated into the systems of preferred embodiments for system diagnosis, for example, for identifying interfering species on the sensor signal and for identifying drifts in baseline and sensitivity of the sensor signal.

[0458] At block 588, a mode determination module, which can be a part of the sensor evaluation module 524, determines in which mode the sensor should be set (or remain). In some embodiments, the system is programmed with three modes: 1) start-up mode; 2) normal mode; and 3) suspended mode. Although three modes are described herein, the preferred embodiments are limited to the number or types of modes with which the system can be programmed. In some embodiments, the system is defined as "in-cal" (in calibra-

tion) in normal mode; otherwise, the system is defined as “out-of-cal” (out of calibration) in start-up and suspended mode. The terms as used herein are meant to describe the functionality and are not limiting in their definitions.

[0459] Preferably, a start-up mode is provided, wherein the start-up mode is set when the system determines that it can no longer remain in suspended or normal mode (for example, due to problems detected by the self-diagnostics module, such as described in more detail above) and/or wherein the system is notified that a new sensor has been inserted. Upon initialization of start-up mode, the system ensures that any old matched data pairs and/or calibration information is purged. In start-up mode, the system initializes the calibration set, such as described in more detail with reference to U.S. Publication No. 2006-0036142-A1. Once the calibration set has been initialized, sensor data is ready for conversion and the system is set to normal mode.

[0460] Preferably, a normal mode is provided, wherein the normal mode is set when the system is accurately and reliably converting sensor data, for example, wherein clinical acceptability is positively determined, aberrant values are negatively determined, and/or the self-diagnostics modules confirms reliability of data. In normal mode, the system continuously (or intermittently) converts (calibrates) sensor data. Additionally, reference analyte values received by the system are matched with sensor data points and added to the calibration set.

[0461] In certain embodiments, the calibration set is limited to a predetermined number of matched data pairs, after which the systems purges old or less desirable matched data pairs when a new matched data pair is added to the calibration set. Less desirable matched data pairs can be determined by inclusion criteria, which include one or more criteria that define a set of matched data pairs that form a substantially optimal calibration set.

[0462] One inclusion criterion comprises ensuring the time stamp of the matched data pairs (that make up the calibration set) span at least a preselected time period (e.g., three hours). Another inclusion criterion comprises ensuring that the time stamps of the matched data pairs are not more than a preselected age (e.g., one week old). Another inclusion criterion ensures that the matched pairs of the calibration set have a substantially evenly distributed amount of high and low raw sensor data points, estimated sensor analyte values, and/or reference analyte values. Another criterion comprises ensuring all raw sensor data, estimated sensor analyte values, and/or reference analyte values are within a predetermined range (e.g., 40 mg/dL to 400 mg/dL for glucose values). Another criterion comprises evaluating the rate of change of the analyte concentration (e.g., from sensor data) during the time stamp of the matched pair(s). For example, sensor and reference data obtained during the time when the analyte concentration is undergoing a slow rate of change can be less susceptible to inaccuracies caused by time lag and other physiological and non-physiological effects. Another criterion comprises evaluating the congruence of respective sensor and reference data in each matched data pair; the matched pairs with the most congruence can be chosen. Another criterion comprises evaluating physiological changes (e.g., low oxygen due to a user’s posture, position, or motion that can cause pressure on the sensor and effect the function of a subcutaneously implantable analyte

sensor, or other effects) to ascertain a likelihood of error in the sensor value. Evaluation of calibration set criteria can comprise evaluating one, some, or all of the above described inclusion criteria. It is contemplated that additional embodiments can comprise additional inclusion criteria not explicitly described herein.

[0463] Unfortunately, some circumstances can exist wherein a system in normal mode can be changed to start-up or suspended mode. In general, the system is programmed to change to suspended mode when a failure of clinical acceptability, aberrant value check and/or other self-diagnostic evaluation is determined, such as described in more detail above, and wherein the system requires further processing to determine whether a system re-start is required (e.g., start-up mode). In general, the system will change to start-up mode when the system is unable to resolve itself in suspended mode and/or when the system detects a new sensor has been inserted (e.g., via system trigger or user input).

[0464] Preferably, a suspended mode is provided wherein the suspended mode is set when a failure of clinical acceptability, aberrant value check, and/or other self-diagnostic evaluation determines unreliability of sensor data. In certain embodiments, the system enters suspended mode when a predetermined time period passes without receiving a reference analyte value. In suspended mode, the calibration set is not updated with new matched data pairs, and sensor data can optionally be converted, but not displayed on the user interface. The system can be changed to normal mode upon resolution of a problem (positive evaluation of sensor reliability from the self-diagnostics module, for example). The system can be changed to start-up mode when the system is unable to resolve itself in suspended mode and/or when the system detects a new sensor has been inserted (via system trigger or user input).

[0465] The systems of preferred embodiments, including a transcutaneous analyte sensor, mounting unit, electronics unit, applicator, and receiver for inserting the sensor, and measuring, processing, and displaying sensor data, provide improved convenience and accuracy because of their designed stability within the host’s tissue with minimum invasive trauma, while providing a discreet and reliable data processing and display, thereby increasing overall host comfort, confidence, safety, and convenience. Namely, the geometric configuration, sizing, and material of the sensor of the preferred embodiments enable the manufacture and use of an atraumatic device for continuous measurement of analytes, in contrast to conventional continuous glucose sensors available to persons with diabetes, for example. Additionally, the sensor systems of preferred embodiments provide a comfortable and reliable system for inserting a sensor and measuring an analyte level for up to 7 days or more without surgery. The sensor systems of the preferred embodiments are designed for host comfort, with chemical and mechanical stability that provides measurement accuracy. Furthermore, the mounting unit is designed with a miniaturized and reusable electronics unit that maintains a low profile during use. The usable life of the sensor can be extended by incorporation of a bioactive agent into the sensor that provides local release of an anti-inflammatory, for example, in order to slow the subcutaneous foreign body response to the sensor.

[0466] After the usable life of the sensor (for example, due to a predetermined expiration, potential infection, or level of



inflammation), the host can remove the sensor and mounting from the skin, and dispose of the sensor and mounting unit (preferably saving the electronics unit for reuse). Another sensor system can be inserted with the reusable electronics unit and thus provide continuous sensor output for long periods of time.

[0467] FIG. 30 is a flow chart 600 that illustrates the process of detecting and processing signal artifacts in some embodiments.

[0468] At block 602, a sensor data receiving module, also referred to as the sensor data module, or processor module, receives sensor data (e.g., a data stream), including one or more time-spaced sensor data points. In some embodiments, the data stream is stored in the sensor for additional processing; in some alternative embodiments, the sensor periodically transmits the data stream to the receiver, which can be in wired or wireless communication with the sensor. In some embodiments, raw and/or filtered data is stored in the sensor and/or transmitted and stored in the receiver, as described in more detail elsewhere herein.

[0469] At block 604, a signal artifacts detection module, also referred to as the signal artifacts detector, or signal reliability module, is programmed to detect transient non-glucose related signal artifacts in the data stream. In some embodiments, the signal artifacts detector can comprise an oxygen detector, a pH detector, a temperature detector, and/or a pressure/stress detector, for example, the signal artifacts detector 29 in FIG. 2. In some embodiments, the signal artifacts detector is located within the processor 22 (FIG. 2) and utilizes existing components of the glucose sensor to detect signal artifacts, for example by pulsed amperometric detection, counter electrode monitoring, reference electrode monitoring, and frequency content monitoring, which are described elsewhere herein. In yet other embodiments, the data can be sent from the sensor to the receiver which comprises programming in the processor 42 (FIG. 4) that performs algorithms to detect signal artifacts, for example such as described with reference to "Cone of Possibility Detection" method and/or by comparing raw data vs. filtered data, both of which are described in more detail elsewhere herein.

[0470] In some exemplary embodiments, the processor module in either the sensor electronics and/or the receiver electronics evaluates an intermittent or continuous signal-to-noise measurement to determine aberrancy of sensor data responsive to a signal-to-noise ratio above a set threshold. In some exemplary embodiments, signal residuals (e.g., by comparing raw and filtered data) are intermittently or continuously analyzed for noise above a set threshold. In some exemplary embodiments, pattern recognition can be used to identify noise associated with physiological conditions, such as low oxygen, or other known signal aberrancies. Accordingly, in these embodiments, the system can be configured, in response to aberrancies in the data stream, to trigger signal estimation, adaptively filter the data stream according to the aberrancy, and the like, as described in more detail elsewhere herein.

[0471] In some embodiments, one or more signal residuals are obtained by comparing received data with filtered data, whereby a signal artifact can be determined. In some embodiments, a signal artifact event is determined to have occurred if the residual is greater than a threshold. In some

exemplary embodiments, another signal artifact event is determined to have occurred if the residual is greater than a second threshold. In some exemplary embodiments, a signal artifact event is determined to have occurred if the residual is greater than a threshold for a period of time or amount of data. In some exemplary embodiments, a signal artifact event is determined to have occurred if a predetermined number of signal residuals above a predetermined threshold occur within a predetermined time period (or amount of data). In some exemplary embodiments, an average of a plurality of residuals is evaluated over a period of time or amount of data to determine whether a signal artifact has occurred. The use of residuals for noise detection can be preferred in circumstances where data gaps (non-continuous) data exists.

[0472] In some exemplary embodiments, a differential, also referred to as a derivative of the residual, is determined by comparing a first residual (e.g., at a first time point) and a second residual (e.g., at a second time point), wherein a signal artifact event is determined to have occurred when the differential is above a predetermined threshold. In some exemplary embodiments, a signal artifact event is determined to have occurred if the differential is greater than a threshold for a period of time or amount of data. In some exemplary embodiments, an average of a plurality of differentials is calculated over a period of time or amount of data to determine whether a signal artifact has occurred.

[0473] Numerous embodiments for detecting signal artifacts are described in more detail in the section entitled, "Signal Artifacts Detection," all of which are encompassed by the signal artifacts detection at block 604.

[0474] At block 606, the processor module is configured to process the sensor data based at least in part on whether the signal artifact event has occurred.

[0475] In some embodiments, the sensor data is filtered in the receiver processor to generate filtered data if the signal artifact event is determined to have occurred; filtering can be performed either on the raw data, or can be performed to further filter received filtered data, or both.

[0476] In some embodiments, signal artifacts detection and processing is utilized in outlier detection, such as described in more detail elsewhere herein, wherein a disagreement between time corresponding reference data and sensor data can be analyzed, e.g., noise analysis data (e.g., signal artifacts detection and signal processing) can be used to determine which value is likely more reliable (e.g., whether the sensor data and/or reference data can be used for processing). In some exemplary embodiments wherein the processor module receives reference data from a reference analyte monitor, a reliability of the received data is determined based on signal artifacts detection (e.g., if a signal artifact event is determined to have occurred.) In some exemplary embodiments, a reliability of the sensor data is determined based on signal artifacts detection (e.g., if the signal artifact event is determined to have not occurred.) The term "reliability," as used herein, is a broad term and is used in its ordinary sense, including, without limitation, a level of confidence in the data (e.g., sensor or reference data), for example, a positive or negative reliance on the data (e.g., for calibration, display, and the like) and/or a rating (e.g., of at least 60%, 70%, 80%, 90% or 100% confidence thereon.)

[0477] In some embodiments wherein a matching data pair is formed by matching reference data to substantially time

corresponding sensor data (e.g., for calibration and/or outlier detection) described in more detail elsewhere herein, matching of a data pair can be configured to occur based on signal artifacts detection (e.g., only if a signal artifact event is determined to have not occurred.) In some embodiments wherein the reference data is included in a calibration factor for use in calibration of the glucose sensor as described in more detail elsewhere herein, the reference data can be configured to be included based on signal artifacts detection (e.g., only if the signal artifact event is determined to have not occurred.) In general, results of noise analysis (e.g., signal artifact detection and/or signal processing) can be used to determine when to use or eliminate a matched pair for use in calibration (e.g., calibration set).

[0478] In some embodiments, a user is prompted for a reference glucose value based on signal artifacts detection (e.g., only if a signal artifact event is determined to have not occurred.) While not wishing to be bound by theory, it is believed certain more preferable times for calibration (e.g., not during noise episodes) can be detected and processed by prompting the user for calibration during those times.

[0479] In some embodiments, results of noise analysis (e.g., signal artifact detection and/or signal processing) can be used to determine how to process the sensor data. For example, different levels of signal processing and display (e.g., raw data, integrated data, filtered data utilizing a first filter, filtered data utilizing a second filter, which may be "more aggressive" than the first filter by filtering over a larger time period, and the like.) Accordingly, the different levels of signal processing and display can be selectively chosen responsive to a reliability measurement, a positive or negative determination of signal artifact, and/or signal artifacts above first and second predetermined thresholds.

[0480] In some embodiments, results of noise analysis (e.g., signal artifact detection and/or signal processing) can be used to determine when to utilize and/or display different representations of the sensor data (e.g., raw vs. filtered data), when to turn filters on and/or off (e.g., processing and/or display of certain smoothing algorithms), and/or when to further process the sensor data (e.g., filtering and/or displaying). In some embodiments, the display of the sensor data is dependent upon the determination of signal artifact(s). For example, when a certain predetermined threshold of signal artifacts have been detected (e.g., noisy sensor data), the system is configured to modify or turn off a particular display of the sensor data (e.g., display filtered data, display processed data, disable display of sensor data, display range of possible data values, display indication of direction of glucose trend data, replace sensor data with predicted/estimated sensor data, and/or display confidence interval representative of a level of confidence in the sensor data.) In some exemplary embodiments, a graphical representation of filtered sensor data is displayed if the signal artifact event is determined to have occurred. Alternatively, when a certain predetermined threshold of signal artifacts has not been detected (e.g., minimal, insignificant, or no noise in the data signal), the system is configured to modify or turn on a particular display of the sensor data (e.g., display unfiltered (e.g., raw or integrated) data, a single data value, an indication of direction of glucose trend data, predicted glucose data for a future time period and/or a confidence interval representative of a level of confidence in the sensor data.)

[0481] In some embodiments wherein a residual (or differential) is determined as described in more detail elsewhere herein, the residual (or differential) is used to modify the filtered data during signal artifact event(s). In one such exemplary embodiment, the residual is measured and then added back into the filtered signal. While not wishing to be bound by theory, it is believed that some smoothing algorithms may result in some loss of dynamic behavior representative of the glucose concentration, which disadvantage may be reduced or eliminated by the adding of the residual back into the filtered signal in some circumstances.

[0482] In some embodiments, the sensor data can be modified to compensate for a time lag, for example by predicting or estimating an actual glucose concentration for a time period considering a time lag associated with diffusion of the glucose through the membrane, digital signal processing, and/or algorithmically induced time lag, for example.

[0483] FIG. 31 is a graph that illustrates a raw data stream from a glucose sensor for approximately 24 hours with a filtered version of the same data stream superimposed on the same graph. Additionally, this graph illustrates a noise episode, the beginning and end of which was detected by a noise detection algorithm of the preferred embodiments, and during which a particular filter was applied to the data. The x-axis represents time in minutes; the y-axis represents the raw and filtered data values in counts. In this example, the raw data stream was obtained in 5 minute intervals from a transcutaneous glucose sensor such as described in more detail above, with reference to FIG. 1B and in U.S. Publication No. US-2006-00201087-A1.

[0484] In section 608 of the data, which encompasses an approximately 14 hour period up to time=2:22, the filtered data was obtained by applying a 3-point moving average window to the raw data. During that period, the noise detection algorithm was applied to detect a noise episode. In this example, the algorithm included the following: calculating a residual signal by subtracting the filtered data from the raw data (e.g., for each 5-minute point); calculating a differential by subtracting the residual for each 5-minute point from its previous 5-minute residual; determining if each differential exceeds a threshold of 5000 counts (and declaring a noisy point if so); and determining whether 6 out of 12 points in the past 1 hour exceed that threshold (and declaring a noise episode if so). Accordingly, a noise episode was declared at time=2:22 and a more aggressive filter was applied as described with reference to section 610.

[0485] In section 610 of the data, also referred to as a noise episode, which encompasses an approximately 5½ hour period up to time=7:57, the filtered data was obtained by applying a 7-point moving average window to the raw data. The 7-point moving average window was in this example was an effective filter in smoothing out the noise in the data signal as can be seen on the graph. During that period, an algorithm was applied to detect when the noise episode had ended. In this example, the algorithm included the following: calculating a residual signal by subtracting the filtered data (using the 3-point moving average filter described above) from the raw data (e.g., for each 5-minute point); calculating a differential of the residual by subtracting the residual for each 5-minute point from its previous 5-minute residual; determining if each differential exceeds a threshold

of 5000 counts (and declaring a noisy point if so); and determining whether less than 2 noisy points had occurred in the past hour (and declaring the noise episode over if so). Accordingly, the noise episode was declared as over at time-7:57 and the less aggressive filter (e.g., 3-point moving average) was again applied with the noise detection algorithm as described with reference to section 608, above.

[0486] In section 612 of the data, which encompasses more than 4 hours of data, the filtered data was obtained by applying a 3-point moving average window to the raw data. During that period, the noise detection algorithm (described above) did not detect a noise episode. Accordingly, raw or minimally filtered data could be displayed to the patient during this time period.

[0487] It was shown that the above-described example provided smoother glucose information during noise episodes, by applying a more aggressive filter to smooth out the noise. It is believed that when displayed, the smoother data will avoid presenting potentially misleading or inaccurate information to the user. Additionally, it was shown in the above-described example that during non-noisy periods (when noise episodes are not detected), raw or less aggressively filtered data can be displayed to the user in order to provide more accurate data with minimal or no associated filter-induced time lag in the data. Furthermore, it is believed that proper detection of noise episodes aids in determining proper times for calibration, ensuring more accurate calibration than may otherwise be possible.

[0488] In the above-described example, the criteria for the onset & offset of noise episodes were different; for example, the onset criteria included 6 out of 12 points in the past 1 hour exceeding a threshold, while the offset criteria included less than 2 noisy points in the past 1 hour. In this example, these different criteria were found to create smoother transitions in the data between the raw and filtered data and avoided false detections of noise episodes.

[0489] FIG. 32 is a flowchart 700 that illustrates a method for processing data from a glucose sensor in certain embodiments. In general, prior art systems display either real-time sensor data (e.g., prospectively calibrated/analyzed) or historical sensor data (e.g., retrospectively calibrated/analyzed). Regarding real-time sensor data display, the sensor data is typically prospectively processed (e.g., calibrated, smoothed, etc) in substantially real-time by a predetermined algorithm, wherein the real-time prospectively processed data are displayed periodically or substantially continuously based on that prospective analysis. Regarding historical sensor data display, the sensor data is typically retrospectively processed (e.g., calibrated, smoothed, etc) after collection of an entire sensor data set, wherein the historical retrospectively processed data are displayed based on the retrospective analysis.

[0490] In contrast to the prior art, the preferred embodiments describe systems and methods for periodically or substantially continuously post-processing (e.g., updating) the substantially real-time graphical representation of glucose data (e.g., trend graph representative of glucose concentration over a previous number of minutes or hours) with processed data, wherein the data has been processed responsive to detection of signal artifacts.

[0491] At block 702, a sensor data receiving module, also referred to as the sensor data module, or processor module,

receives sensor data (e.g., a data stream), including one or more time-spaced sensor data points. In some embodiments, the data stream is stored in the sensor for additional processing; in some alternative embodiments, the sensor periodically transmits the data stream to the receiver, which can be in wired or wireless communication with the sensor. In some embodiments, raw and/or filtered data is stored in the sensor and/or transmitted and stored in the receiver, as described in more detail elsewhere herein.

[0492] At block 704, a signal artifacts detection module, also referred to as the signal artifacts detector, or signal reliability module, optionally detects transient non-glucose related signal artifacts in the data stream, such as described in more detail above with reference to block 604.

[0493] At block 706, the processor module is configured to optionally process the sensor data based at least in part on whether the signal artifact event has occurred, such as described in more detail with reference to block 606 above.

[0494] At block 708, an output module, also referred to as the processor module, provides output to the user via the user interface. The output is representative of the estimated glucose value, which is determined by converting the sensor data into a meaningful glucose value such as described in more detail elsewhere herein. User output can be in the form of a numeric estimated glucose value, an indication of directional trend of glucose concentration, and/or a graphical representation of the estimated glucose data over a period of time, for example. Other representations of the estimated glucose values are also possible, for example audio and tactile. In some embodiments, the output module displays both a "real-time" glucose value (e.g., a number representative of the most recently measure glucose concentration) and a graphical representation of the post-processed sensor data, which is described in more detail, below.

[0495] In one embodiment, such as shown in FIG. 3A, the estimated glucose value is represented by a numeric value. In other exemplary embodiments, such as shown in FIGS. 3B to 3D, the user interface graphically represents the estimated glucose data trend over predetermined a time period (e.g., one, three, and nine hours, respectively). In alternative embodiments, other time periods can be represented. In some embodiments, the measured analyte value is represented by a numeric value. In alternative embodiments, other time periods can be represented. In alternative embodiments, pictures, animation, charts, graphs, ranges of values, and numeric data can be selectively displayed.

[0496] At block 710, the processor module is configured to periodically or substantially continuously post-process (e.g., update) the displayed graphical representation of the data corresponding to the time period according to the received data. For example, the glucose trend information (e.g., for the previous 1-, 3-, or 9-hour trend graphs shown in FIGS. 3B to 3D) can be updated to better represent actual glucose values during signal artifacts. In some embodiments, the processor module post-processes segments of data (e.g., 1-, 3-, or 9-hour trend graph data) every few seconds, minutes, hours, days, or anywhere in between, and/or when requested by a user (e.g., in responsive to a button-activation such as a request for display of a 3-hour trend graph screen).

[0497] In general, post-processing includes the processing performed by the processor module (e.g., within the hand-

held receiver unit) on “recent” sensor data (e.g., data that is inclusive of time points within the past few minutes to few hours) after its initial display of the sensor data and prior to what is generally termed “retrospective analysis” in the art (e.g., analysis that is typically accomplished retrospectively at one time, in contrast to intermittently, periodically, or continuously, on an entire data set, such as for display of sensor data for physician analysis). Post-processing can include programming performed to recalibrate the sensor data (e.g., to better match to reference values), fill in data gaps (e.g., data eliminated due to noise or other problems), smooth out (filter) sensor data, compensate for a time lag in the sensor data, and the like, which is described in more detail, below. Preferably, the post-processed data is displayed on a personal hand-held unit (e.g., such as on the 1-, 3-, and 9-hour trend graphs of the receiver of FIGS. 3A to 3D) in “real time” (e.g., inclusive of recent data within the past few minutes or hours) and can be updated (post-processed) automatically (e.g., periodically, intermittently, or continuously) or selectively (e.g., responsive to a request) when new or additional information is available (e.g., new reference data, new sensor data, etc). In some alternative embodiments, post-processing can be triggered dependent upon the duration of a noise episode; for example, data associated with noise events extending past about 30 minutes can be processed and/or displayed differently than data during the initial 30 minutes of a noise episode.

[0498] In one exemplary embodiment, the processor module filters the data stream to recalculate data for a previous time period and periodically or substantially continuously displays a graphical representation of the recalculated data for that time period (e.g., trend graph).

[0499] In another exemplary embodiment, the processor module adjusts the data for a time lag (e.g., removes a time lag induced by real-time filtering) from data for a previous time period and displays a graphical representation of the time lag adjusted data for that time period (e.g., trend graph).

[0500] In another exemplary embodiment, the processor module algorithmically smoothes one or more sensor data points over a moving window (e.g., including time points before and after the one or more sensor data points) for data for a previous time period and displays a graphical representation of the updated, smoothed data for that time period (e.g., trend graph).

[0501] Although a few examples of post-processing are described herein, one skilled in the art appreciates a variety of data processing that can be applied to these systems and methods, including any of the processing steps described in more detail elsewhere herein.

[0502] Methods and devices that are suitable for use in conjunction with aspects of the preferred embodiments are disclosed in U.S. Pat. No. 4,994,167; U.S. Pat. No. 4,757,022; U.S. Pat. No. 6,001,067; U.S. Pat. No. 6,741,877; U.S. Pat. No. 6,702,857; U.S. Pat. No. 6,558,321; U.S. Pat. No. 6,931,327; and U.S. Pat. No. 6,862,465.

[0503] Methods and devices that are suitable for use in conjunction with aspects of the preferred embodiments are disclosed in U.S. Publication No. US-2005-0176136-A1; U.S. Publication No. US-2005-0251083-A1; U.S. Publication No. US-2005-0143635-A1; U.S. Publication No. US-2005-0181012-A1; U.S. Publication No. US-2005-

0177036-A1; U.S. Publication No. US-2005-0124873-A1; U.S. Publication No. US-2005-0051440-A1; U.S. Publication No. US-2005-0115832-A1; U.S. Publication No. US-2005-0245799-A1; U.S. Publication No. US-2005-0245795-A1; U.S. Publication No. US-2005-0242479-A1; U.S. Publication No. US-2005-0182451-A1; U.S. Publication No. US-2005-0056552-A1; U.S. Publication No. US-2005-0192557-A1; U.S. Publication No. US-2005-0154271-A1; U.S. Publication No. US-2004-0199059-A1; U.S. Publication No. US-2005-0054909-A1; U.S. Publication No. US-2005-0112169-A1; U.S. Publication No. US-2005-0051427-A1; U.S. Publication No. US-2003-0032874-A1; U.S. Publication No. US-2005-0103625-A1; U.S. Publication No. US-2005-0203360-A1; U.S. Publication No. US-2005-0090607-A1; U.S. Publication No. US-2005-0187720-A1; U.S. Publication No. US-2005-0161346-A1; U.S. Publication No. US-2006-0015020-A1; U.S. Publication No. US-2005-0043598-A1; U.S. Publication No. US-2003-0217966-A1; U.S. Publication No. US-2005-0033132-A1; U.S. Publication No. US-2005-0031689-A1; U.S. Publication No. US-2004-0045879-A1; U.S. Publication No. US-2004-0186362-A1; U.S. Publication No. US-2005-0027463-A1; U.S. Publication No. US-2005-0027181-A1; U.S. Publication No. US-2005-0027180-A1; U.S. Publication No. US-2006-0020187-A1; U.S. Publication No. US-2006-0036142-A1; U.S. Publication No. US-2006-0020192-A1; U.S. Publication No. US-2006-0036143-A1; U.S. Publication No. US-2006-0036140-A1; U.S. Publication No. US-2006-0019327-A1; U.S. Publication No. US-2006-0020186-A1; U.S. Publication No. US-2006-0020189-A1; U.S. Publication No. US-2006-0036139-A1; U.S. Publication No. US-2006-0020191-A1; U.S. Publication No. US-2006-0020188-A1; U.S. Publication No. US-2006-0036141-A1; U.S. Publication No. US-2006-0020190-A1; U.S. Publication No. US-2006-0036145-A1; U.S. Publication No. US-2006-0036144-A1; U.S. Publication No. US-2006-0016700-A1; U.S. Publication No. US-2006-0142651-A1; U.S. Publication No. US-2006-0086624-A1; U.S. Publication No. US-2006-0068208-A1; U.S. Publication No. US-2006-0040402-A1; U.S. Publication No. US-2006-0036142-A1; U.S. Publication No. US-2006-0036141-A1; U.S. Publication No. US-2006-0036143-A1; U.S. Publication No. US-2006-0036140-A1; U.S. Publication No. US-2006-0036139-A1; U.S. Publication No. US-2006-0142651-A1; U.S. Publication No. US-2006-0036145-A1; and U.S. Publication No. US-2006-0036144-A1.

[0504] Methods and devices that are suitable for use in conjunction with aspects of the preferred embodiments are disclosed in U.S. application Ser. No. 09/447,227 filed Nov. 22, 1999 and entitled “DEVICE AND METHOD FOR DETERMINING ANALYTE LEVELS”; U.S. application Ser. No. 11/335,879 filed Jan. 18, 2006 and entitled “CELLULOSE-BASED INTERFERENCE DOMAIN FOR AN ANALYTE SENSOR”; U.S. application Ser. No. 11/334,876 filed Jan. 18, 2006 and entitled “TRANSCUTANEOUS ANALYTE SENSOR”; U.S. application Ser. No. 11/333,837 filed Jan. 17, 2006 and entitled “LOW OXYGEN IN VIVO ANALYTE SENSOR”.

[0505] All references cited herein, including but not limited to published and unpublished applications, patents, and literature references, are incorporated herein by reference in their entirety and are hereby made a part of this specification. To the extent publications and patents or patent appli-

cations incorporated by reference contradict the disclosure contained in the specification, the specification is intended to supersede and/or take precedence over any such contradictory material.

[0506] The term “comprising” as used herein is synonymous with “including,” “containing,” or “characterized by,” and is inclusive or open-ended and does not exclude additional, unrecited elements or method steps.

[0507] All numbers expressing quantities of ingredients, reaction conditions, and so forth used in the specification are to be understood as being modified in all instances by the term “about.” Accordingly, unless indicated to the contrary, the numerical parameters set forth herein are approximations that may vary depending upon the desired properties sought to be obtained. At the very least, and not as an attempt to limit the application of the doctrine of equivalents to the scope of any claims in any application claiming priority to the present application, each numerical parameter should be construed in light of the number of significant digits and ordinary rounding approaches.

[0508] The above description discloses several methods and materials of the present invention. This invention is susceptible to modifications in the methods and materials, as well as alterations in the fabrication methods and equipment. Such modifications will become apparent to those skilled in the art from a consideration of this disclosure or practice of the invention disclosed herein. Consequently, it is not intended that this invention be limited to the specific embodiments disclosed herein, but that it cover all modifications and alternatives coming within the true scope and spirit of the invention.

What is claimed is:

1. A method of analyzing data from an analyte sensor, the method comprising:

receiving data from the analyte sensor, the data comprising at least one sensor data point;

determining whether a signal artifact event has occurred; and

processing the received data, wherein the processing is based at least in part upon whether the signal artifact event has occurred.

2. The method of claim 1, further comprising filtering the received data to generate filtered data.

3. The method of claim 2, wherein determining whether a signal artifact has occurred comprises comparing the received data with the filtered data to obtain at least one residual.

4. The method of claim 3, wherein a signal artifact event is determined to have occurred if the residual exceeds a threshold value.

5. The method of claim 4, further comprising determining whether another signal artifact event has occurred, wherein another signal artifact event has occurred if the residual exceeds a second threshold value.

6. The method of claim 3, wherein a signal artifact event is determined to have occurred if the residual exceeds a threshold value for a predetermined period of time or for a predetermined amount of data.

7. The method of claim 6, wherein determining whether a signal artifact has occurred further comprises determining whether a predetermined number of residuals exceeds a

threshold over a predetermined period of time, or whether a predetermined amount of data exceeds a threshold.

8. The method of claim 3, wherein determining whether a signal artifact event has occurred further comprises determining a differential between a first residual at a first time point and a second residual at a second time point.

9. The method of claim 8, wherein determining whether a signal artifact event has occurred further comprises determining whether a predetermined number of differentials exceeds a threshold over a predetermined period of time, or whether an amount of data exceeds a threshold.

10. The method of claim 1, further comprising receiving reference data from a reference analyte monitor, the reference data including at least one reference data point.

11. The method of claim 10, wherein processing the received data further comprises determining a reliability of the received data, wherein processing is conducted if the signal artifact event is determined to have not occurred.

12. The method of claim 10, further comprising matching the reference data to substantially time corresponding received data to form a matching data pair, wherein the reference data is matched if the signal artifact event is determined to have not occurred.

13. The method of claim 10, further comprising including the reference data in a calibration factor for use in calibrating the glucose sensor, wherein the reference data is included if the signal artifact event is determined to have not occurred.

14. The method of claim 1, further comprising prompting a user for a reference glucose value, wherein prompting is conducted if the signal artifact event is determined to have not occurred.

15. The method of claim 1, wherein processing the received data comprises displaying a graphical representation of the received data.

16. The method of claim 1, wherein processing the received data comprises filtering the received data, wherein filtering is conducted if the signal artifact event is determined to have occurred.

17. The method of claim 1, further comprising filtering the received data, wherein processing the received data comprises displaying a graphical representation of the filtered data, wherein processing is conducted if the signal artifact event is determined to have occurred.

18. The method of claim 1, further comprising filtering the received data to generate filtered data, wherein determining whether a signal artifact event has occurred further comprises comparing the received data with the filtered data to obtain a residual, and wherein processing the received data comprises utilizing the residual to modify the filtered data.

19. The method of claim 1, further comprising filtering the received data to generate filtered data, wherein determining whether a signal artifact event has occurred further comprises comparing the received data with the filtered data to obtain a residual and deriving a differential of the residual by calculating a first derivative of the residual, and wherein processing the received data comprises utilizing the differential to modify the filtered data.

20. The method of claim 1, wherein processing the received data comprises compensating for a time lag.

21. The method of claim 1, wherein processing the received data comprises displaying a graphical representation of the received data.

22. The method of claim 21, wherein the received data is an unfiltered digital signal.

23. The method of claim 1, wherein processing the received data comprises disabling display of a graphical representation of the received data, wherein processing is conducted if the signal artifact event is determined to have occurred.

24. The method of claim 1, wherein processing the received data comprises displaying a range of glucose values, wherein processing is conducted if the signal artifact event is determined to have occurred.

25. The method of claim 1, wherein processing the received data comprises displaying a graphical indication of glucose trend, wherein processing is conducted if the signal artifact event is determined to have occurred.

26. The method of claim 1, wherein processing the received data comprises generating at least one estimated glucose value and displaying a graphical representation of the estimated glucose value, wherein processing is conducted if the signal artifact event is determined to have occurred.

27. The method of claim 26, wherein processing the received data comprises generating a confidence interval for at least one estimated glucose value and displaying a graphical representation of the confidence interval, wherein processing is conducted if the signal artifact event is determined to have occurred.

28. A method for processing data from a glucose sensor, the method comprising:

receiving data from the glucose sensor, the received data comprising at least one sensor data point;

displaying a graphical representation of the data corresponding to a time period; and

post-processing the displayed graphical representation of the data corresponding to the time period.

29. The method of claim 28, wherein post-processing is conducted periodically.

30. The method of claim 28, wherein post-processing is conducted substantially continuously.

31. The method of claim 28, further comprising determining whether a signal artifact event has occurred and processing the received data prior to the displaying step, wherein the processing is based at least in part upon whether the signal artifact event has occurred.

32. The method of claim 28, wherein post-processing comprises filtering the data to recalculate data corresponding to the time period and displaying a graphical representation of the recalculated data corresponding to the time period.

33. The method of claim 28, wherein the step of post-processing comprises:

recalculating data corresponding to the time period, wherein a time lag induced by real-time filtering is substantially removed from the data corresponding to the time period; and

displaying a graphical representation of the recalculated data corresponding to the time period.

34. The method of claim 33, wherein recalculating the data comprises algorithmically smoothing at least one sensor data point over a moving window, wherein the moving window comprises time points before and after the sensor data point is obtained.

35. The method of claim 28, further comprising displaying a current glucose value representative of the most recently obtained sensor data point.

36. A system configured to process data from an analyte sensor, the system comprising:

a data receiving module configured to receive sensor data from the analyte sensor, the data comprising at least one sensor data point;

a signal artifacts module configured to detect a signal artifact in the sensor data; and

a processor module configured to process the sensor data, wherein processing is dependent at least in part upon whether the signal artifact is detected.

37. The system of claim 36, wherein the signal artifacts module is configured to compare raw sensor data with filtered sensor data to determine a residual.

38. The system of claim 37, wherein the signal artifacts module is configured to detect a signal artifact if the residual exceeds a threshold value.

39. The system of claim 37, wherein the signal artifacts module is configured to detect a signal artifact if a predetermined number of residuals exceed a threshold value for a predetermined period of time or for a predetermined amount of data.

40. The system of claim 37, wherein the signal artifacts module is configured to compare a first residual with a second signal residual to determine a differential.

41. The system of claim 40, wherein the signal artifacts module is configured to detect a signal artifact if the differential exceeds a threshold value.

42. The system of claim 40, wherein the signal artifacts module is configured to detect a signal artifact if a predetermined number of differentials exceed a threshold value for a predetermined period of time or for a predetermined amount of data.

43. The system of claim 36, further comprising a reference data module configured to receive reference data from a reference glucose monitor, the reference data comprising at least one reference data point.

44. The system of claim 43, wherein the signal artifacts module is configured to determine a reliability of the sensor data if the signal artifact is detected.

45. The system of claim 43, wherein the processor module is configured to form at least one matched data pair by matching reference data to substantially time corresponding sensor data.

46. The system of claim 45, wherein the processor module is configured to form a matching data pair if a signal artifact is not detected.

47. The system of claim 43, wherein the processor module is configured to utilize the reference data for calibrating the glucose sensor if a signal artifact is not detected.

48. The system of claim 43, wherein the processor module is configured to prompt a user for a reference glucose value if a signal artifact is not detected.

49. The system of claim 36, wherein the data receiving module is configured to receive raw sensor data.

50. The system of claim 49, wherein the raw sensor data comprises integrated digital data.

51. The system of claim 49, wherein the processor module is configured to display a graphical representation of the raw sensor data if a signal artifact is not detected.

52. The system of claim 49, wherein the data receiving module is configured to receive filtered sensor data.

53. The system of claim 52, wherein the processor module is configured to display a graphical representation of the filtered sensor data if a signal artifact is detected.

54. The system of claim 36, wherein the processor module is configured to filter the sensor data.

55. The system of claim 54, wherein the processor module is configured to display a graphical representation of the filtered sensor data if a signal artifact is detected.

56. The system of claim 36, wherein the processor module is configured to not display the sensor data if a signal artifact is detected.

57. The system of claim 36, wherein the processor module is configured to display a range of glucose values if a signal artifact is detected.

58. The system of claim 36, wherein the processor module is configured to display a directional indicator of glucose trend if a signal artifact is detected.

59. The system of claim 36, wherein the processor module is configured to display at least one estimated glucose value if a signal artifact is detected.

60. The system of claim 36, wherein the processor module is configured to display a confidence interval for at least one estimated glucose value if a signal artifact is detected.

61. A system configured to process data from an analyte sensor, the system comprising:

a data receiving module configured to receive sensor data from the analyte sensor, the data comprising at least one sensor data point;

an output module configured to display a substantially real-time numerical value corresponding to a most

recently received sensor data point and a graphical representation of sensor data corresponding to a time period; and

a processor module configured to post-process the graphical representation of the data corresponding to the time period, wherein the output module is configured to display the post-processed data.

62. The system of claim 61, wherein post-processing is conducted periodically.

63. The system of claim 61, wherein post-processing is conducted substantially continuously.

64. The system of claim 61, wherein the processor module is configured to automatically post-process the graphical representation of the data corresponding to the time period.

65. The system of claim 61, wherein the processor module is configured to post-process the graphical representation of the data corresponding to the time period responsive to a request.

66. The system of claim 61, wherein the output module is configured to automatically display the post-processed graphical representation of the data corresponding to the time period.

67. The system of claim 61, wherein the output module is configured to display the post-processed graphical representation of the data corresponding to the time period responsive to a request.

\* \* \* \* \*