



US 20070148690A1

(19) **United States**

(12) **Patent Application Publication**

Shao et al.

(10) **Pub. No.: US 2007/0148690 A1**

(43) **Pub. Date: Jun. 28, 2007**

(54) **ANALYSIS OF GENE EXPRESSION PROFILES USING SEQUENTIAL HYBRIDIZATION**

(76) Inventors: **Zhifeng Shao**, Charlottesville, VA (US);
Sitong Sheng, Charlottesville, VA (US);
Shoudan Liang, Palo Alto, CA (US)

Correspondence Address:
MORRISON & FOERSTER LLP
12531 HIGH BLUFF DRIVE
SUITE 100
SAN DIEGO, CA 92130-2040 (US)

(21) Appl. No.: **11/703,921**

(22) Filed: **Feb. 6, 2007**

Related U.S. Application Data

(62) Division of application No. 10/222,459, filed on Aug. 16, 2002, now Pat. No. 7,189,509.

(60) Provisional application No. 60/312,696, filed on Aug. 16, 2001.

Publication Classification

(51) **Int. Cl.**
C12Q 1/68 (2006.01)
C12M 3/00 (2006.01)
(52) **U.S. Cl.** **435/6; 435/287.2; 356/319**

(57) **ABSTRACT**

This invention relates generally to analysis of gene expression profiles. In particular, the present invention provides a method for a method for analyzing gene expression profiles of a cell, which method comprises: a) providing for isolated mRNA or cDNA target sequences from a cell; b) sequentially hybridizing said isolated mRNA or cDNA target sequences with a plurality of nucleotide probes; and c) assessing the sequential hybridization between said isolated mRNA or cDNA target sequences and said plurality of nucleotide probes to analyze gene expression profiles of said cell. Systems for analyzing gene expression profiles are also provided. Optical devices for detecting hybridization signal are further provided.

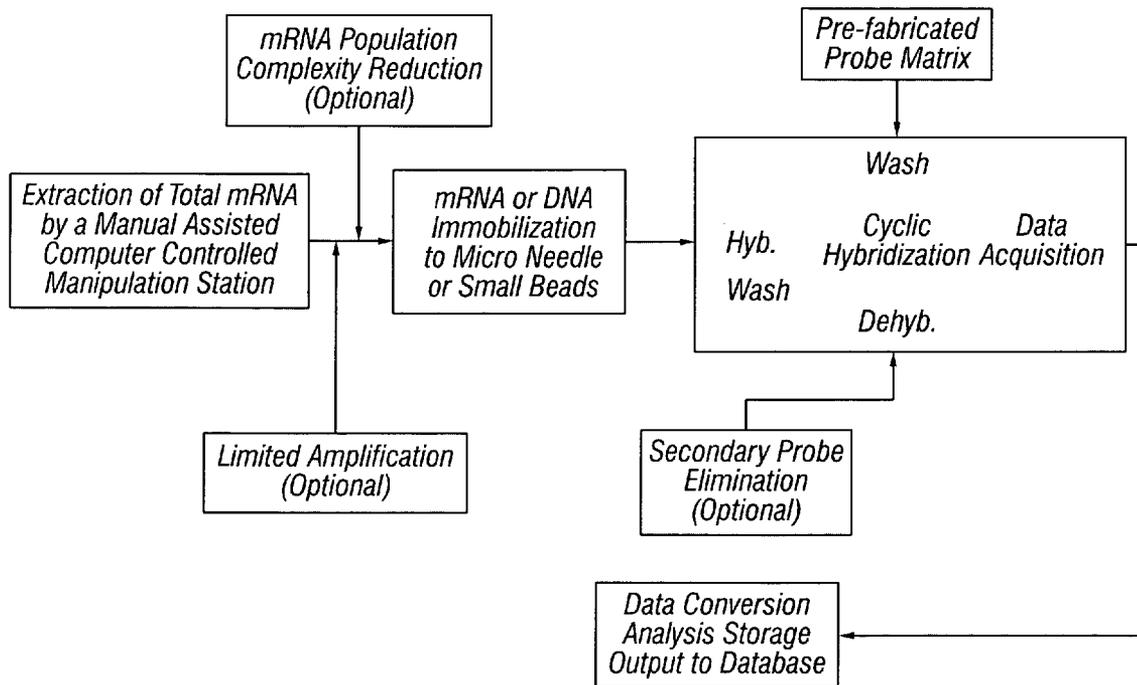

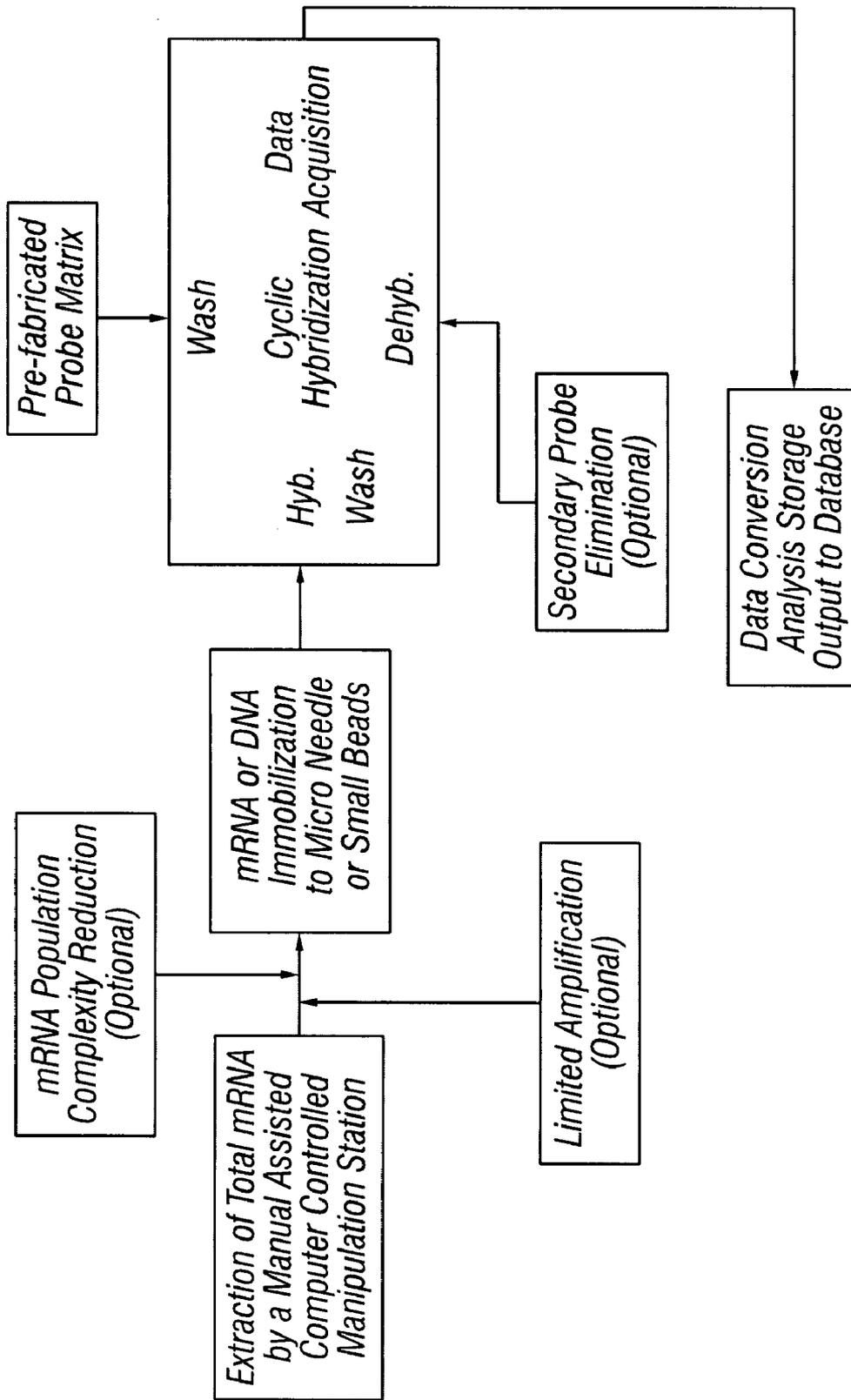
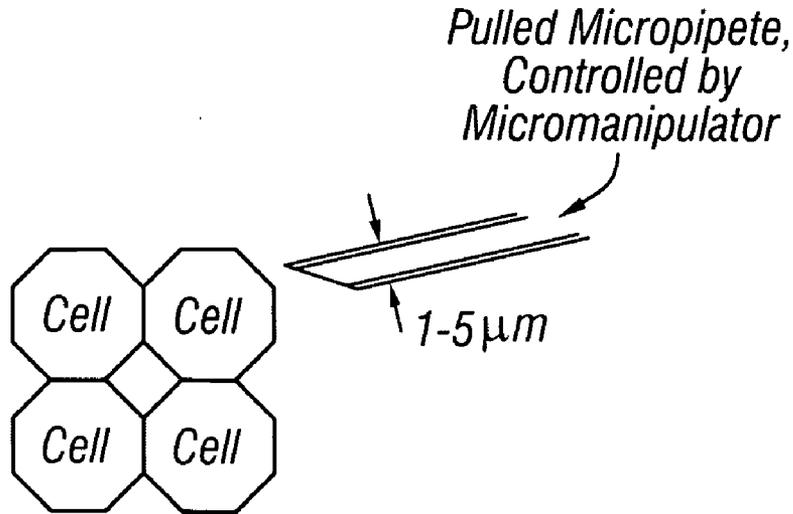

FIG. 1



Stage (A) Obtaining Material

Method 1. In situ Extraction of Cellular Content

- 1. Insertion of Micropipette into Individual Cells*
- 2. Extraction of Cytosol by Sucktion and Mixing with Buffer*
- 3. Transfer into a Micro Well at Step a in (B)*

Method 2. Release Cellular Content in Micro Well

- 1. Isolate Individual Cells by Microdissection, or Flowcytometry*
- 2. Pick Up with a Micropipette by Sucktion*
- 3. Release into Micro Well at Step a in (B)*

FIG. 2A

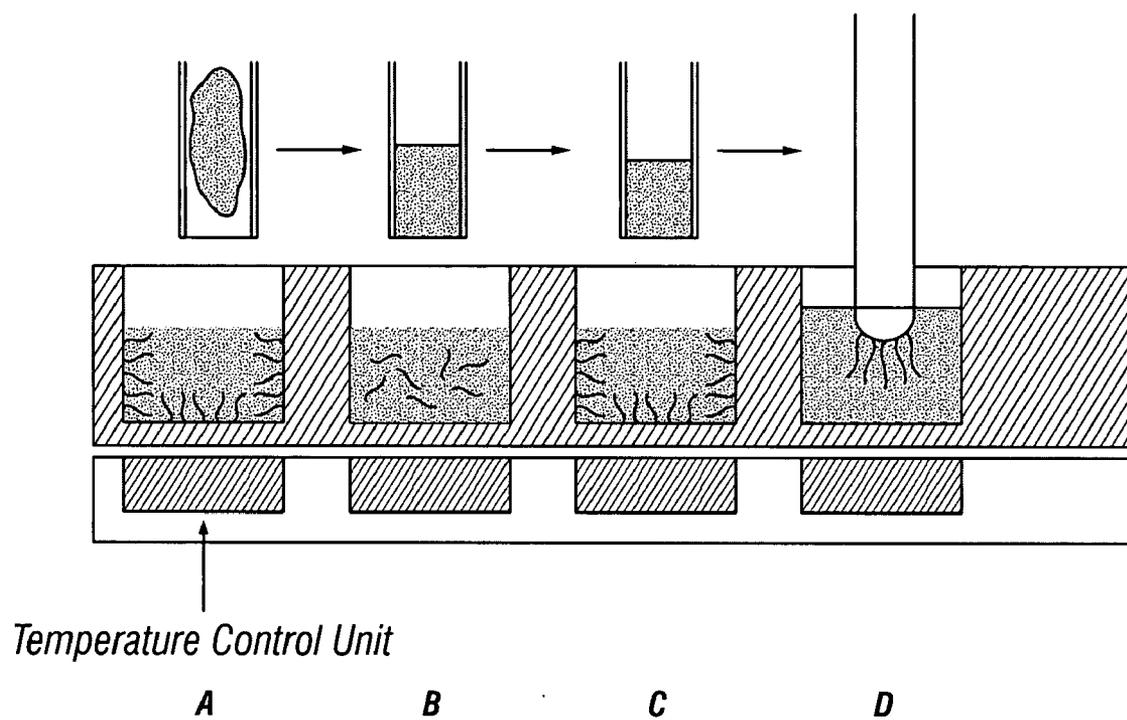

Stage (B) Extraction, Isolation, and Immobilization of mRNA, cDNA

FIG. 2B

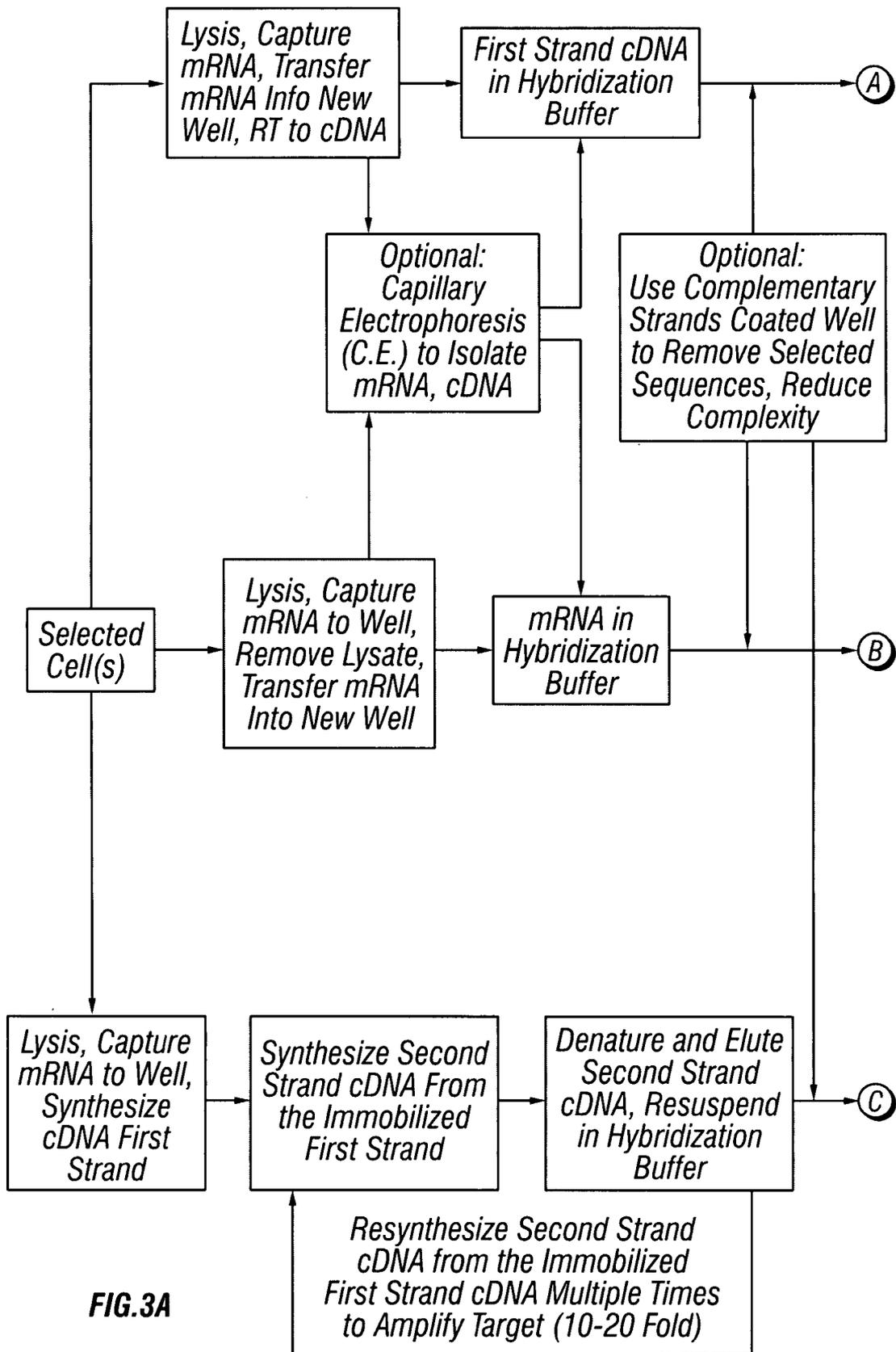

FIG. 3A

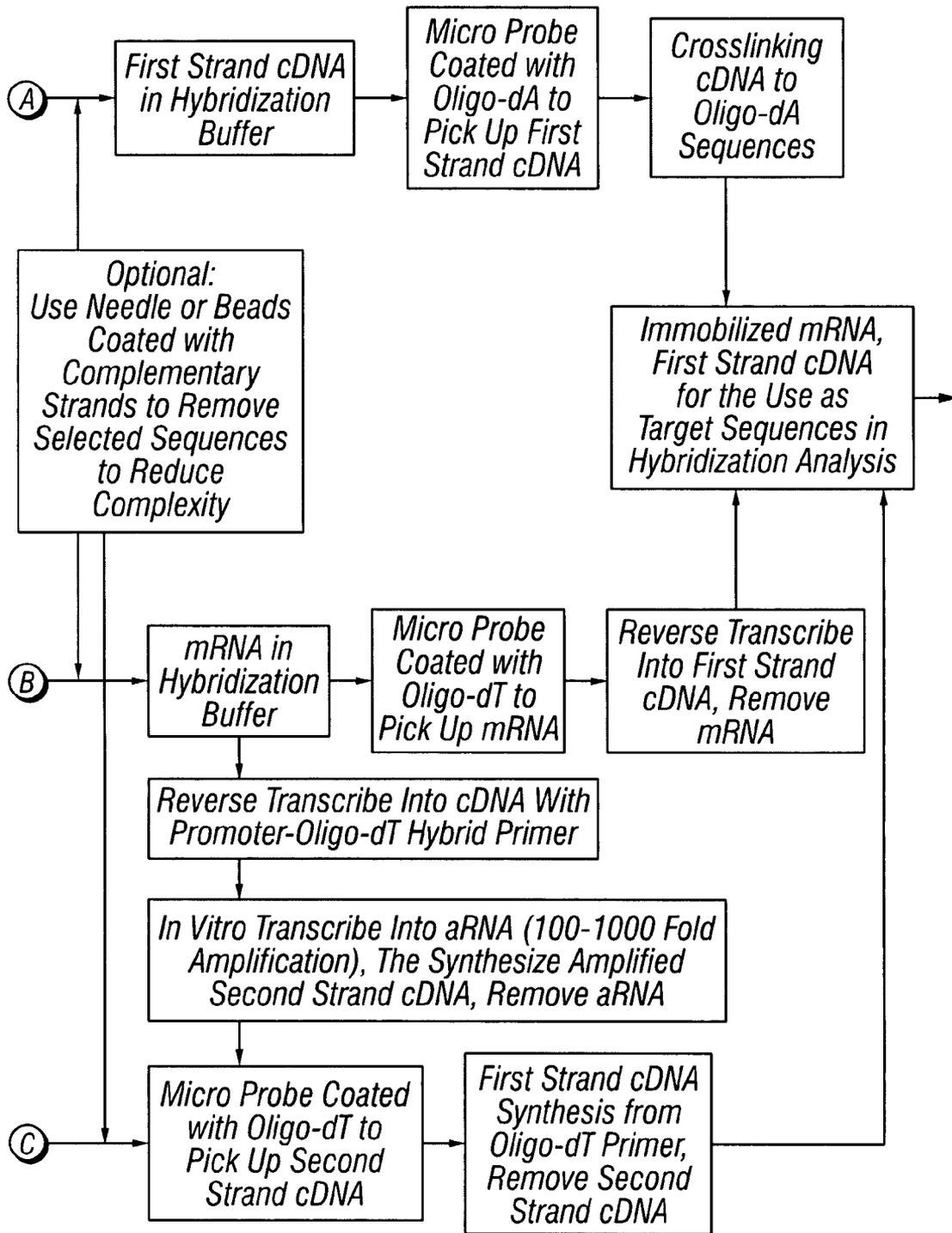
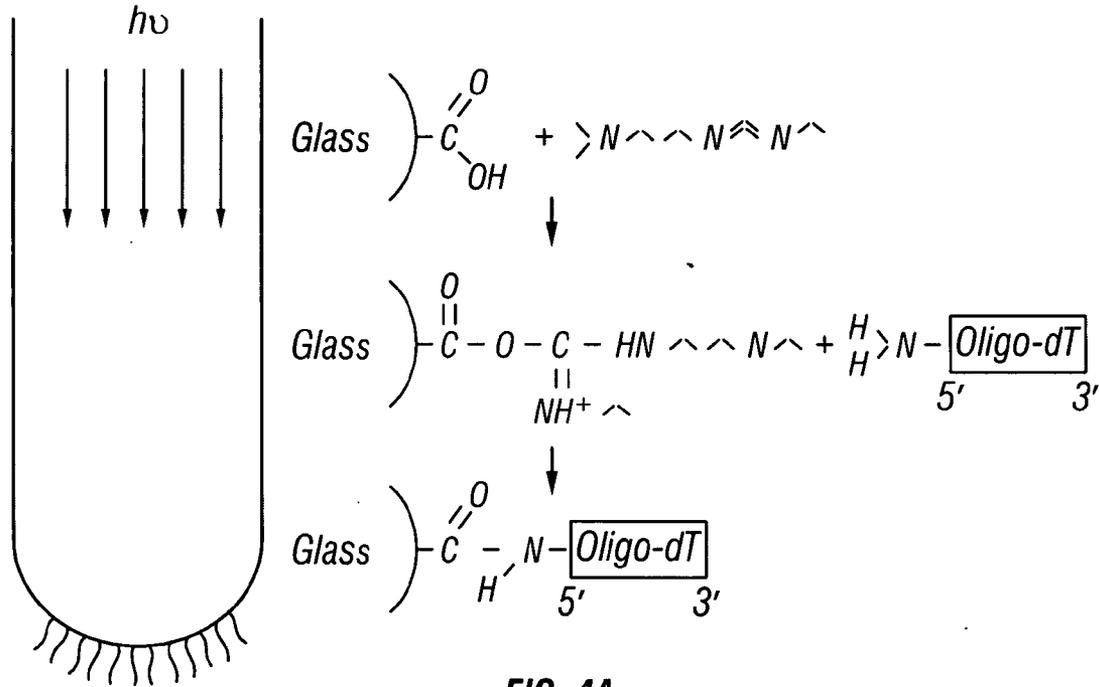
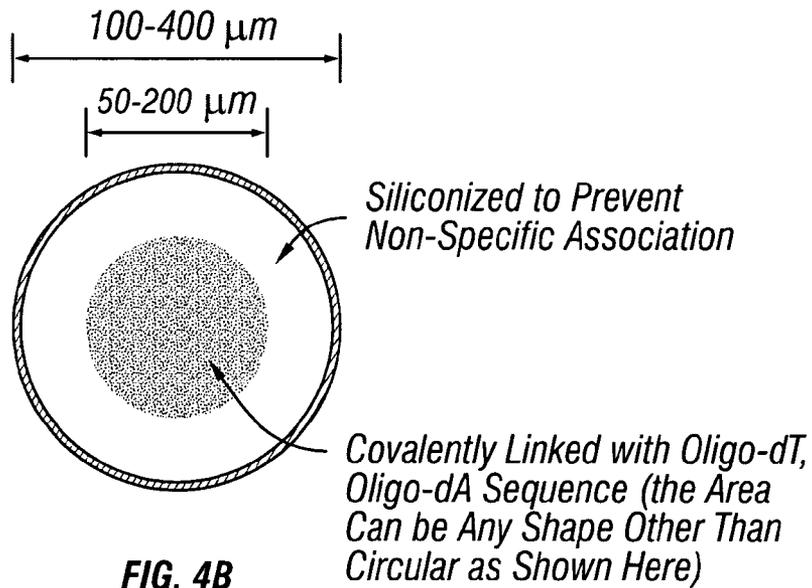

FIG.3B

Covalently Link Oligo-dT to Glass Carboxylated Glass Surface (Micro Needle) Using Following Procedure:



“ ” : Oligo-dT (15-40); Oligo-dA (15-40) Sequences
Covalently Linked on Glass/Quartz Surface



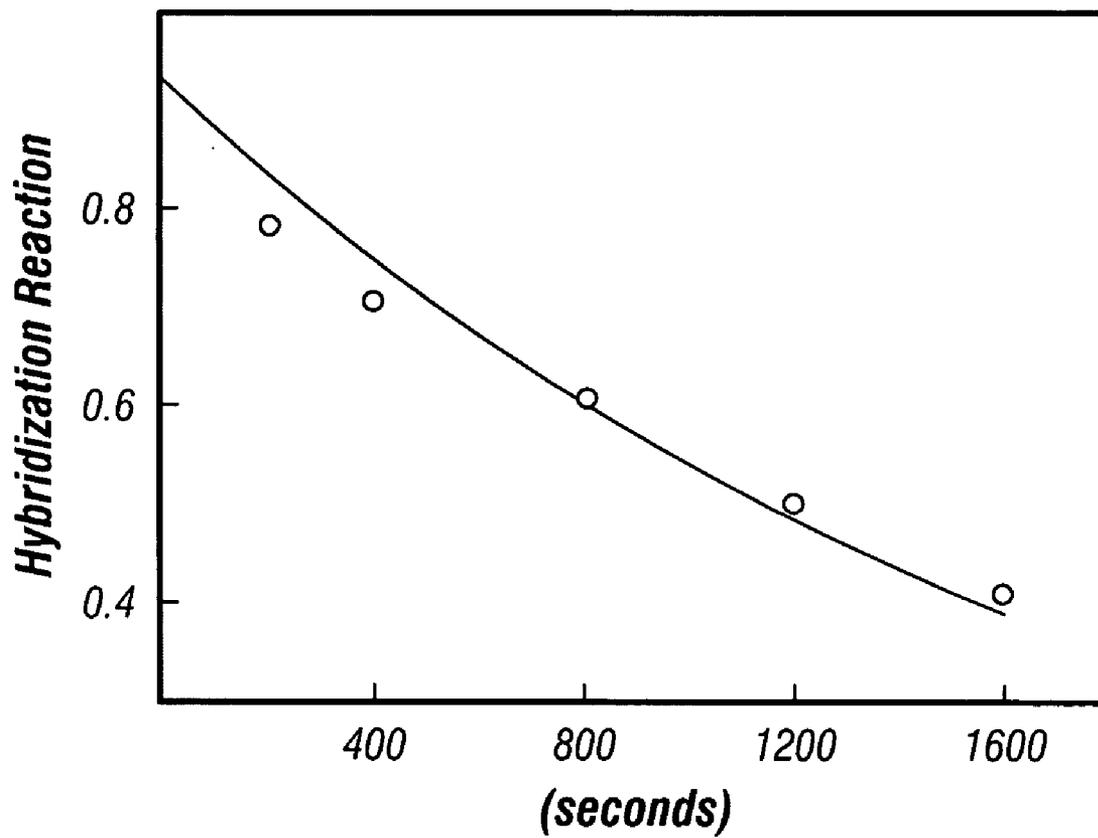
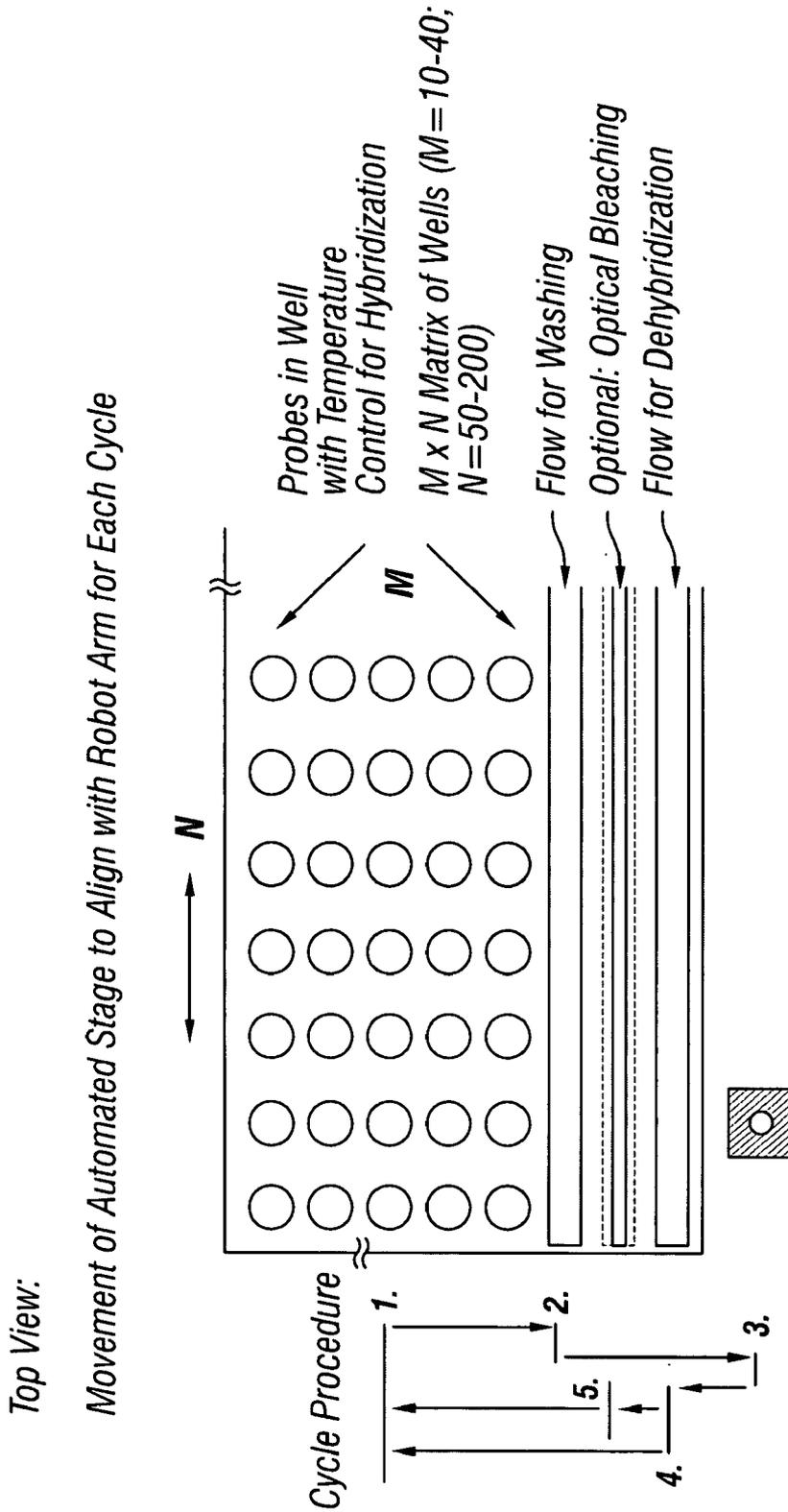

FIG.6



Analytical Cycle: 1. Hybridization, 2. Washing, 3. Detection, 4. Dehybridization, 5. Photobleaching (optional). 4.->1. & 5.->1. Start Next Cycle

FIG.7A

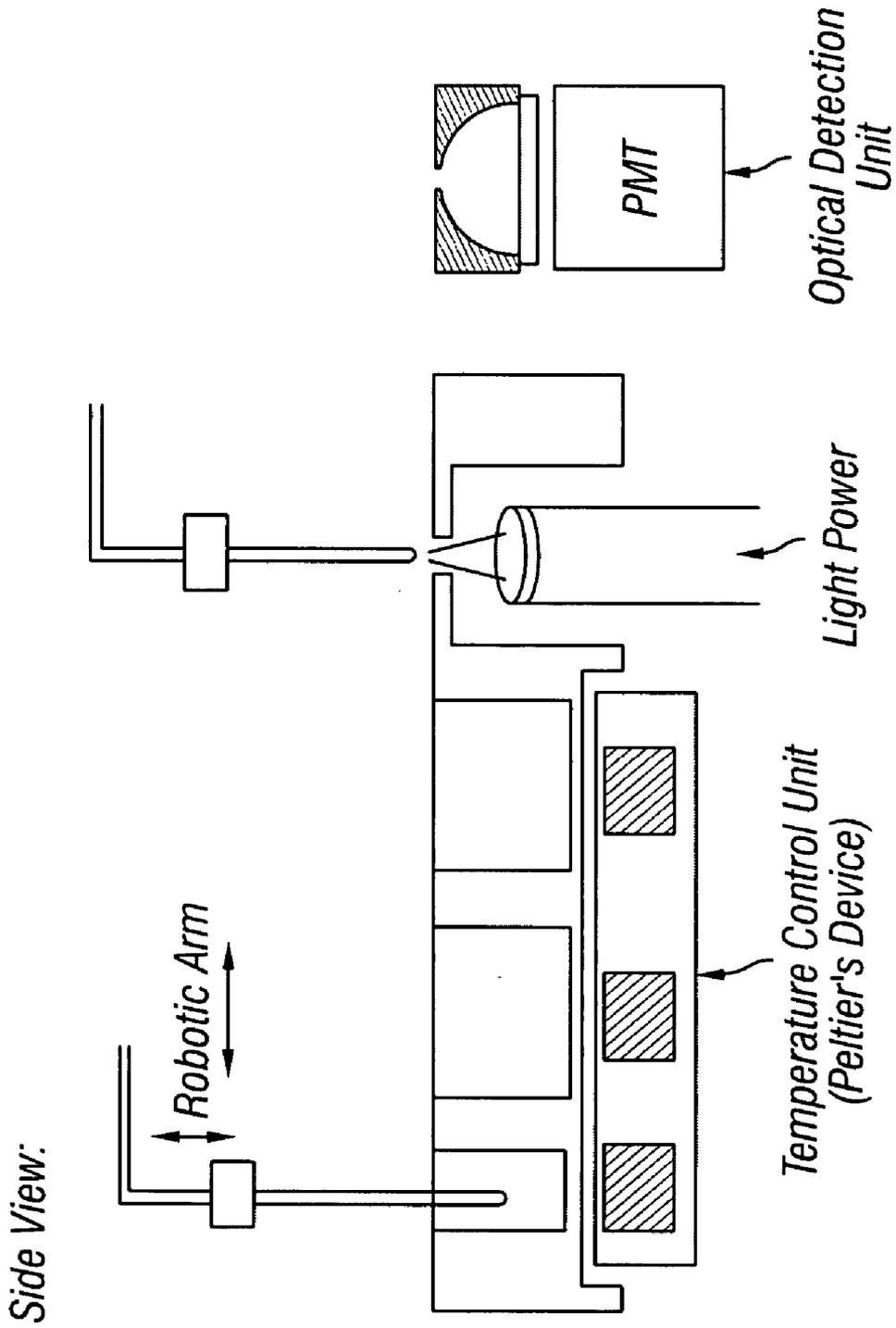

FIG. 7B

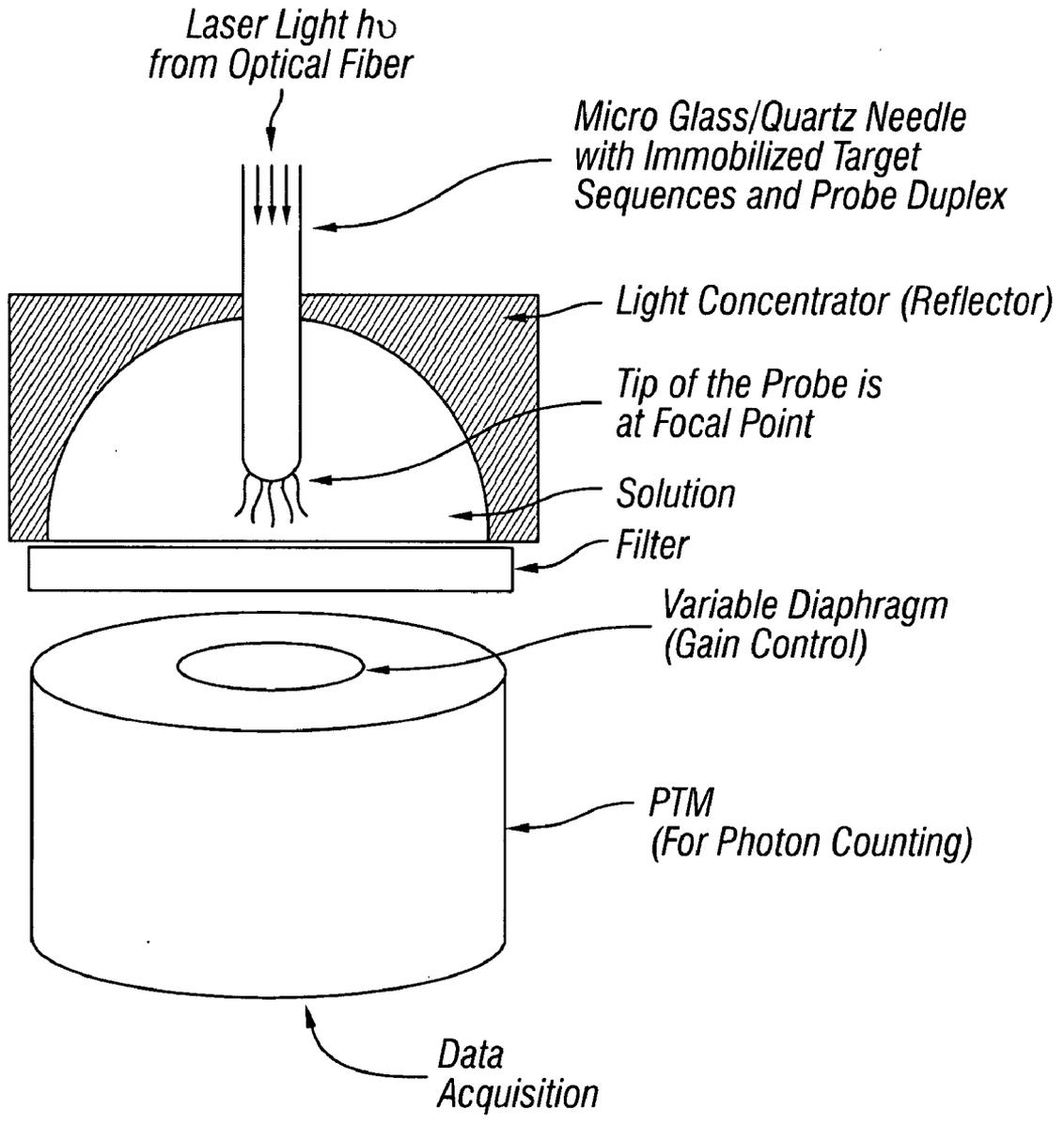

FIG.8A

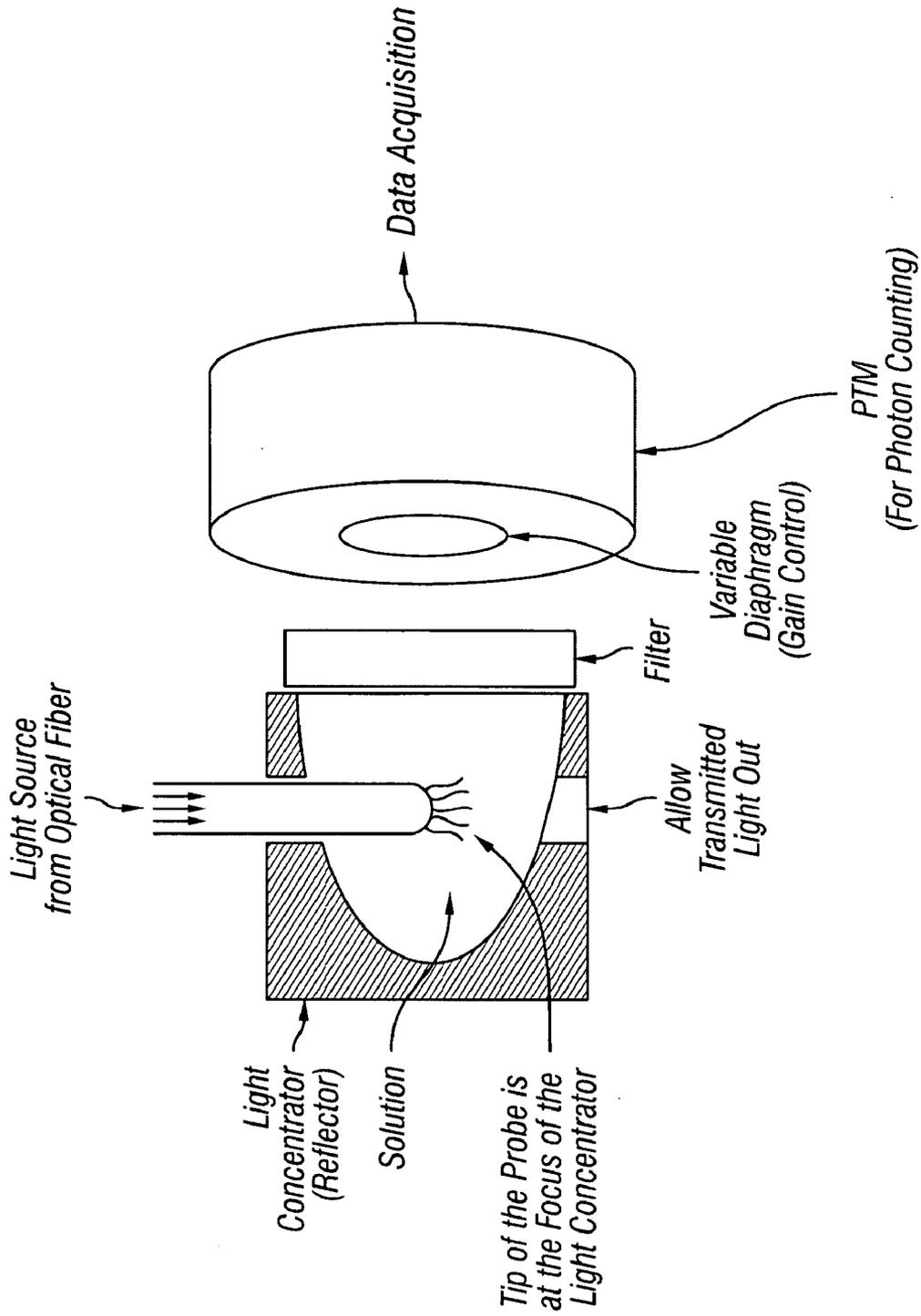

FIG. 8B

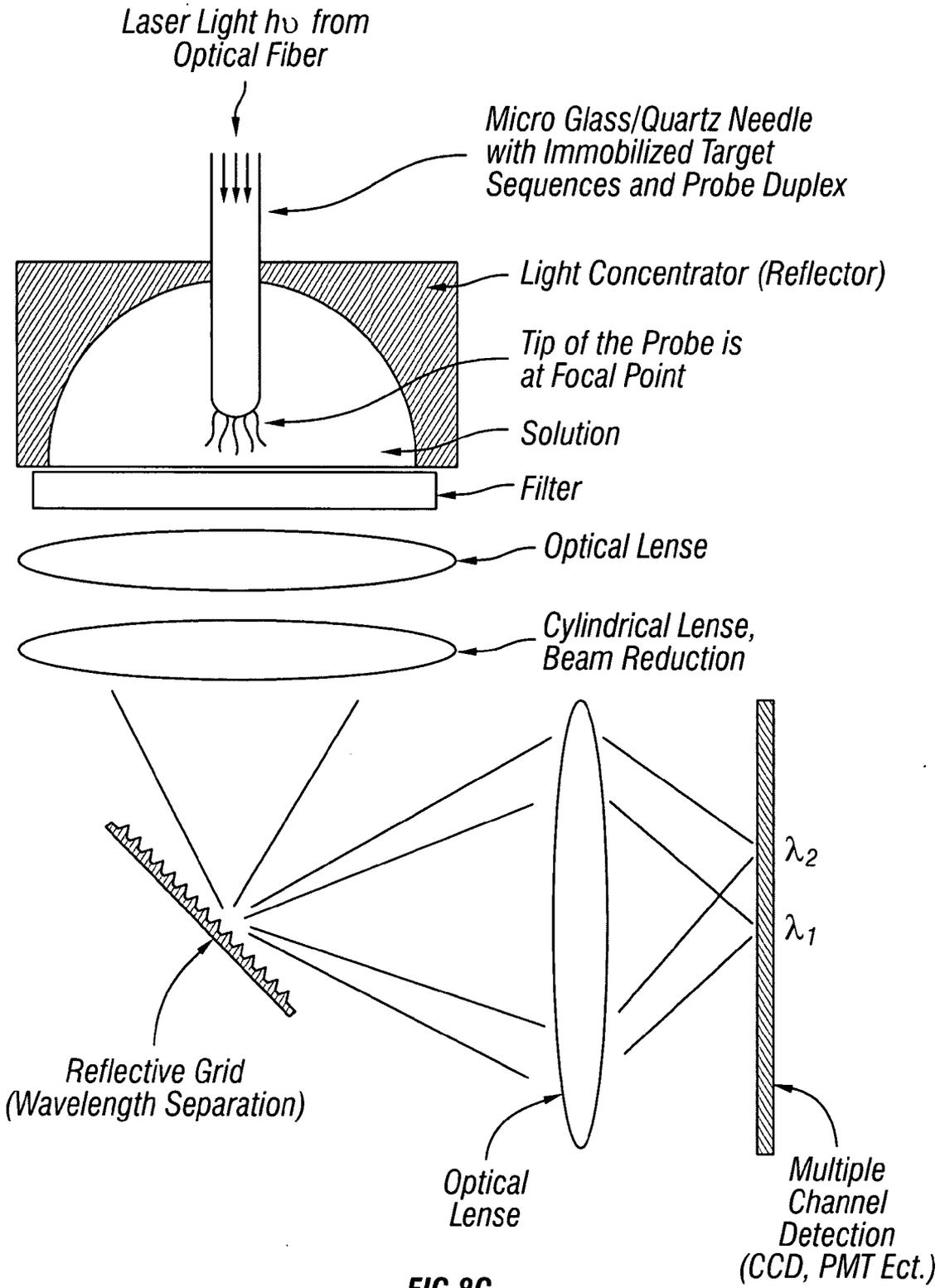

FIG.8C

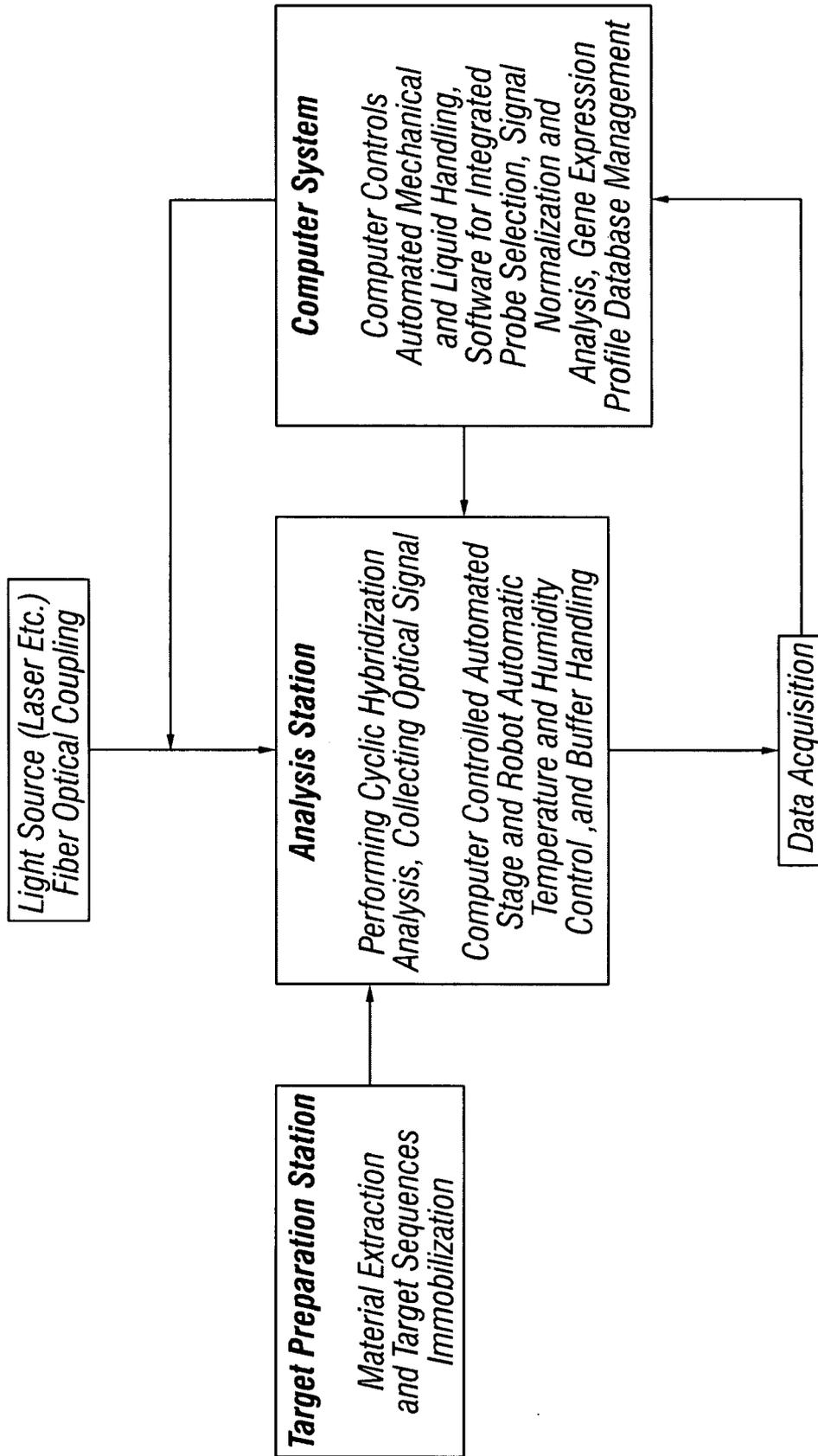

FIG.9

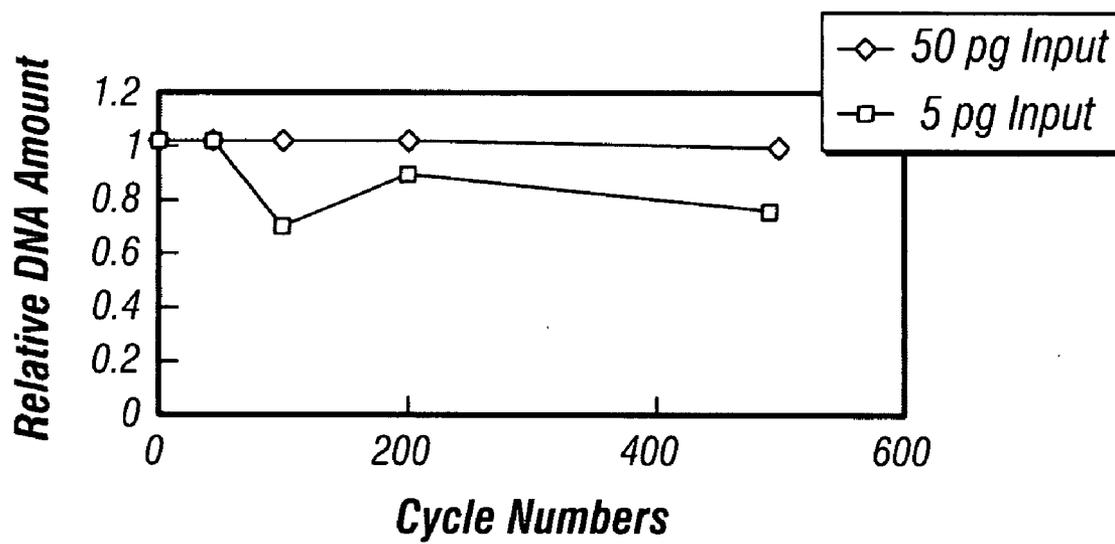

FIG.10

