



US 20050148391A1

(19) **United States**

(12) **Patent Application Publication**
Tain

(10) **Pub. No.: US 2005/0148391 A1**

(43) **Pub. Date: Jul. 7, 2005**

(54) **POKER DEALING DEVICE INCORPORATED WITH DIGITAL RECORDER SYSTEM**

(52) **U.S. Cl. 463/42; 273/149 P**

(76) **Inventor: Liu Gui Tain, Los Angeles, CA (US)**

(57) **ABSTRACT**

Correspondence Address:
DAVID AND RAYMOND PATENT GROUP
1050 OAKDALE LANE
ARCADIA, CA 91006 (US)

A poker dealing device includes a housing and a card reader. The housing has a receiving cavity for receiving cards, and a dispensing slot communicating with the receiving cavity for allowing the cards to be dispensed therethrough in a one-by-one manner. The card reader is provided at the dispensing slot at a position out of the receiving cavity for reading a card value when the card is dispensed out of the receiving cavity through the dispensing slot. As a result, it is guaranteed that the card values of the cards in the receiving cavity would be kept in a secrete manner until the cards are dispensed out of the receiving cavity through the dispensing slot.

(21) **Appl. No.: 10/749,966**

(22) **Filed: Jan. 2, 2004**

Publication Classification

(51) **Int. Cl.⁷ A63F 9/24**

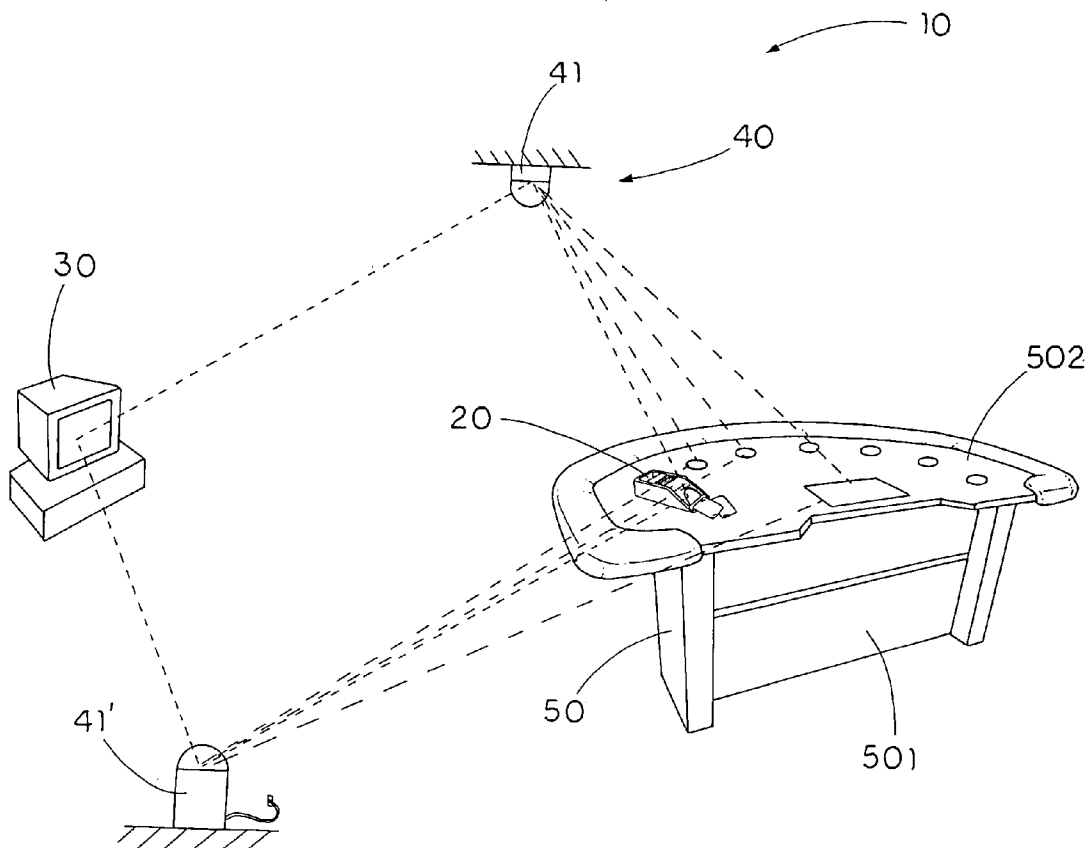

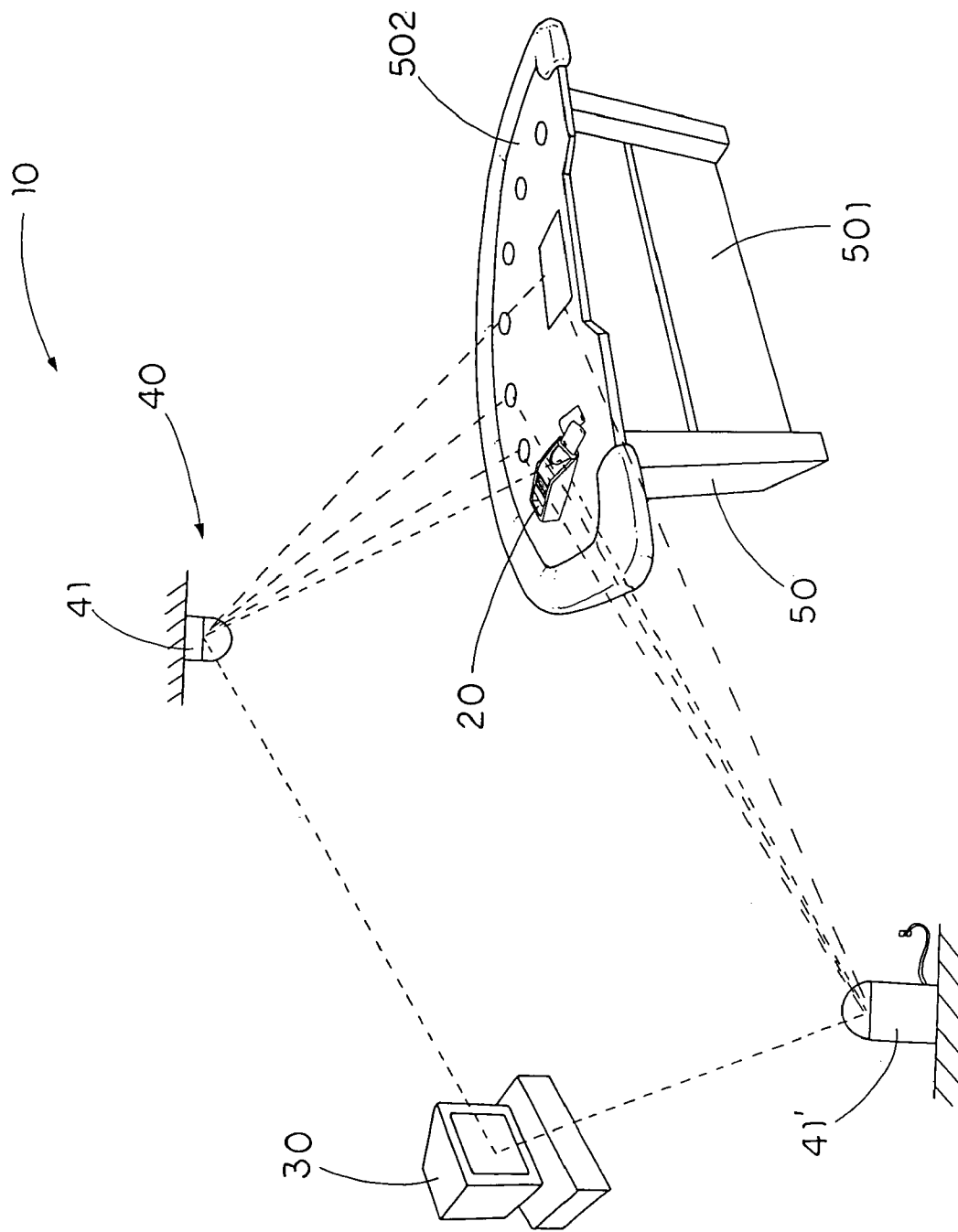

FIG. 1

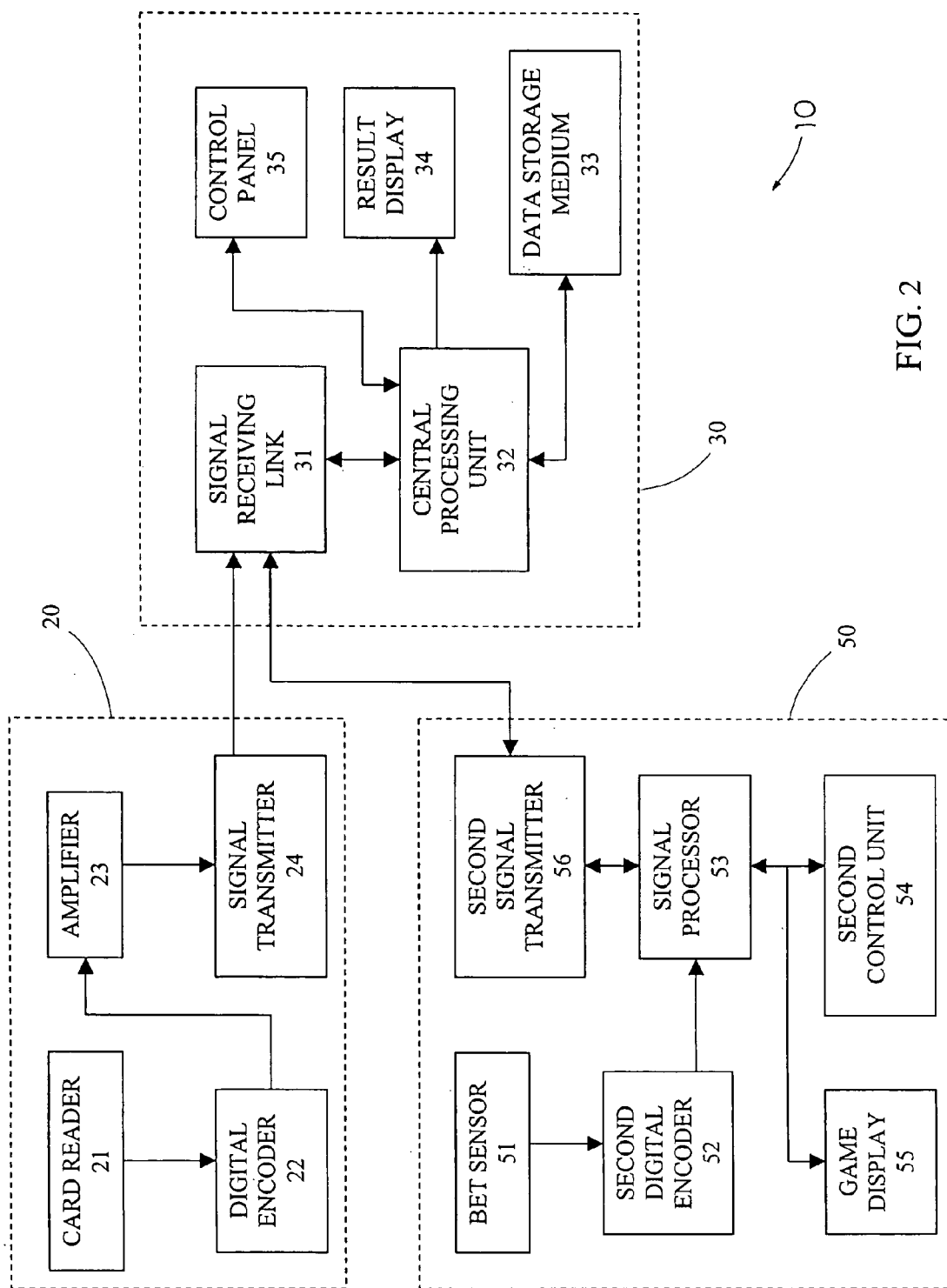

FIG. 2

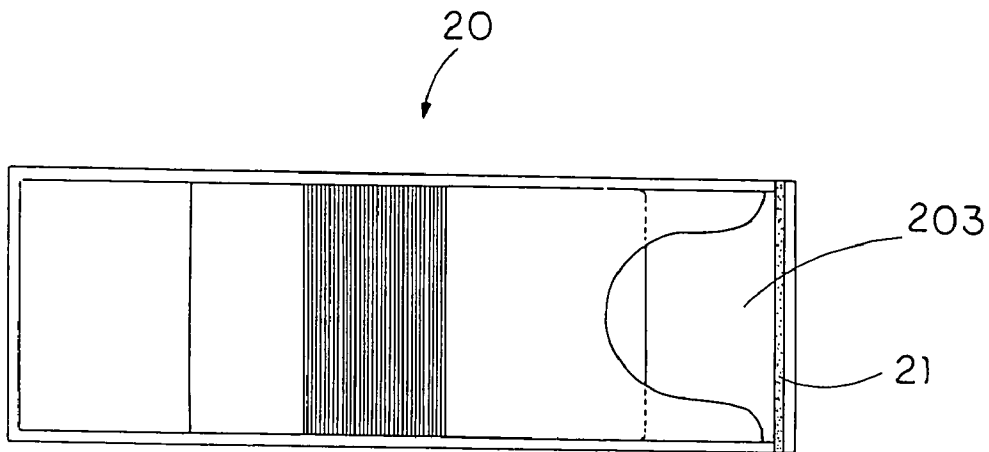

FIG. 3

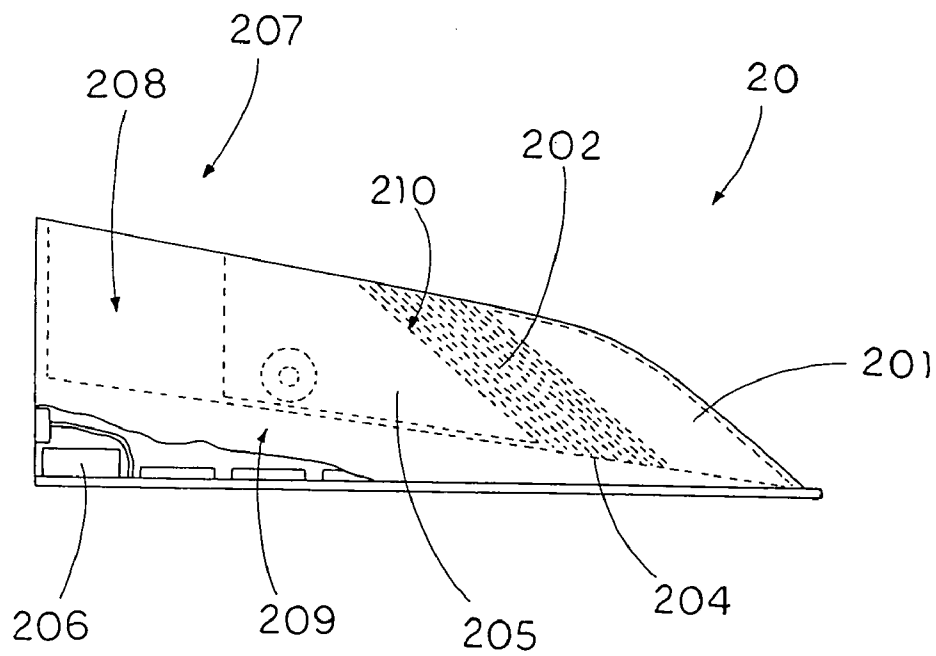

FIG. 4

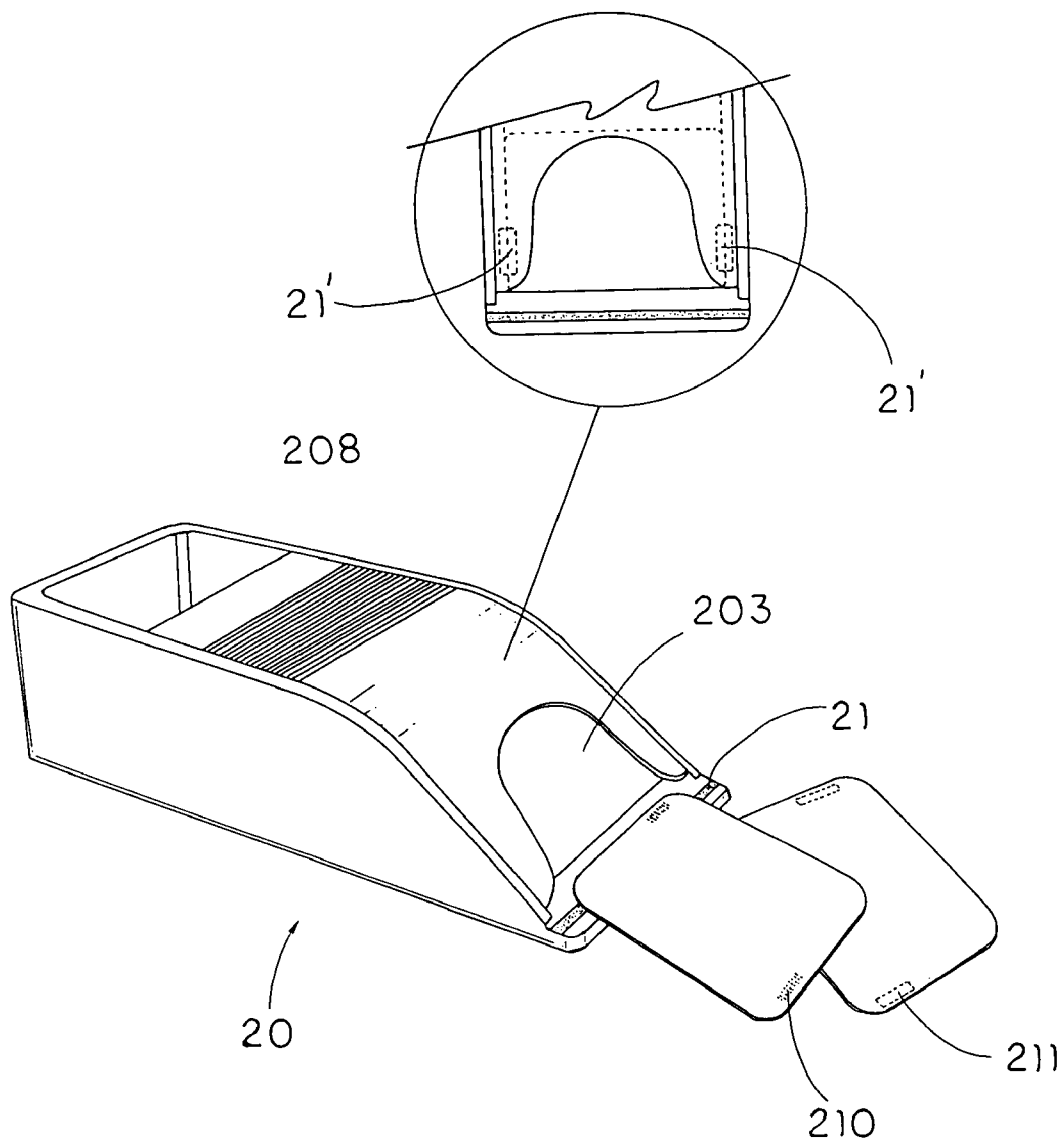

FIG. 5

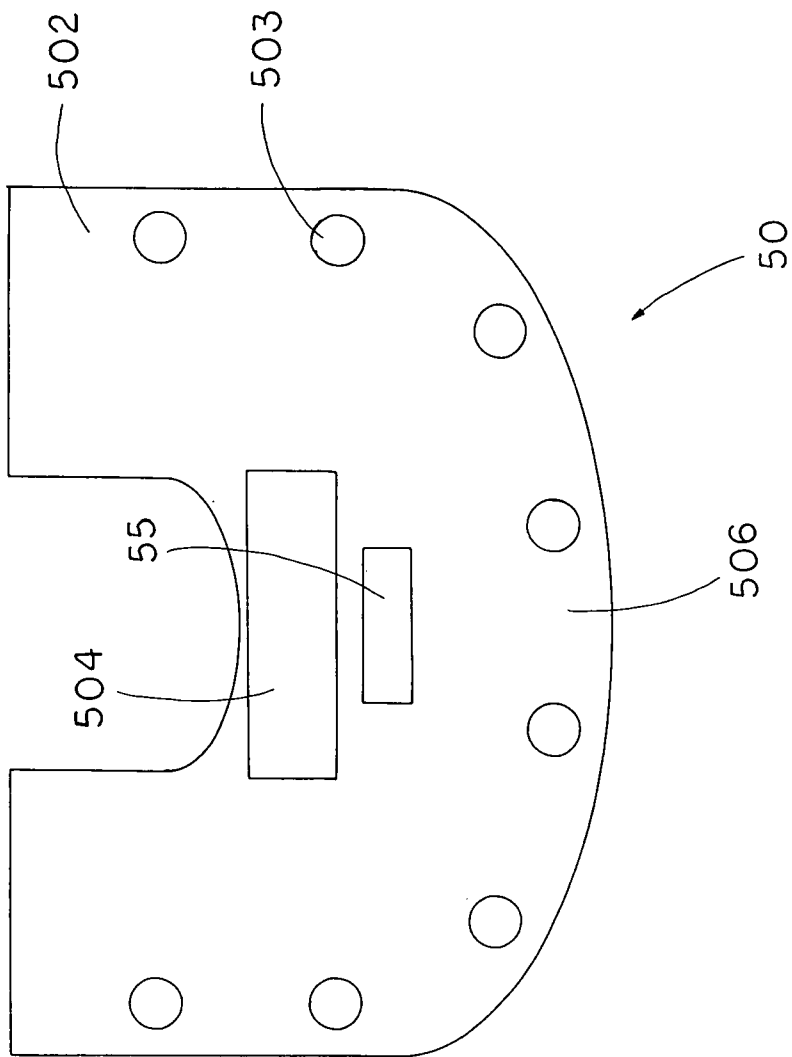

FIG. 6

**POKER DEALING DEVICE INCORPORATED
WITH DIGITAL RECORDER SYSTEM**

**BACKGROUND OF THE PRESENT
INVENTION**

[0001] 1. Field of Invention

[0002] The present invention is related to a poker dealing device for dispensing playing cards, and more particularly to a poker dealing device capable of automatically reading the value of the playing card that is being dispensed through a dispensing slot of the poker dealing device for further processing for management purposes.

[0003] 2. Description of Related Arts

[0004] Card games have a long history as an entertainment, and many of them are potentially suitable for gambling. Poker, baccarat and blackjack are among the most popular mean of gambling in casinos. In spite of their own rules, they all based on a standard deck of playing cards, which includes fifty-two cards separated into four suits, clubs, spades, hearts and diamonds. The cards are ranked from high to low in the order of Ace, King, Queen, Jack, 10, 9, 8, 7, 6, 5, 4, 3 and 2. Sometimes, more than one deck of cards is used for certain card games. According to the rules, the combination of the plays cards determines who wins and who loses.

[0005] In a poker game, each player places an initial bet into the pot before the cards are dealt. The dealer then deals the cards face down around the table to the player for many times until each player has five cards, i.e., a hand. In the course of dealing the cards, the players decide to place bets or withdraw from the game and the winner takes the pot. The values of hands are ranked from high to low in the following order: Royal Flush, Straight Flush, Four of a Kind, Full House, Flush, Straight, Three of a Kind, Two Pair and One Pair. Royal Flush is composed of 10, Jack, Queen, King and Ace in the same suit. Straight Flush is composed of five cards in numerical order, all of the same suit. Four of a Kind is composed of four cards of the same numerical rank and another random card. Full House is composed of three cards having the same numerical rank, and two remaining cards also having the same numerical rank. Flush is composed of five cards of the same suit. Straight is composed of five cards in numerical order, regardless of their suits. Three of a Kind is composed of three cards of the same numerical rank, and two random cards that are not a pair. Two Pair is composed of two sets of pairs, and another random card. One pair is composed of one pair and three random cards.

[0006] In a Blackjack game, all face cards have a value of 10. Aces have a value of either 1 or 10, and other cards are worth their face value. The dealer deals card to players until they are satisfied. If the total value of the player's cards exceed 21, the player "bust" and loses her bet. If the total value is higher than that of the dealer, the player wins. If the total value is lower than that of the dealer, the player loses. If the player has the same total value as the dealer, it is a push. The dealer must draw cards until she has at least 17 or higher. In other words, if the dealer gets 16, she must draw another card.

[0007] The goal of Baccarat is to assemble a hand of two or three cards with a point value as close to nine as possible. Usually, the game is played by a banker and player. The

banker deals two hands of two cards each, face down. These hands are for the banker plus the dealer's own hand. Other participants at the table may bet on either hand or both to beat the banker's hand. If the player declares "banco", it means they are betting the total value of the bank's funds and all other bets are withdrawn.

[0008] All the abovementioned card games require extensive dealing of cards and lengthened procedure of betting, in which some game participants may be able to gain illegitimate advantages by cheating. In order to make cheating more difficult, nowadays, most casinos are using card dealing shoe to reduce the exposure of the cards to the participant's hands. Traditionally, the card dealing shoe is shaped as an elongated box having a cavity for receiving cards. A chute is disposed in the cavity in a downhill manner and a wedge is placed on the chute pushing the cards received therein against a dispensing slot of card dealing shoe. The dealer slides one card through the dispensing slot at one time and delivers the dispensed card to the players and herself. Because the cards are preserved in the cavity of card dealing shoe, they are protected from tempering by the participants of the card game. Furthermore, the card is dispensed in such a way the each card leaving the card dispensing shoe has its face down on the table. In other words, no one is able to learn the value the dispensed card by a quick glance. Thus, the card dealing shoe reduces the risk of cheating in a card game.

[0009] Although the card dealing shoe helps reduce cheating for card games, it is not perfect. Some skillful people may be capable of switching the dealt cards with prepared substitutes and therefore acquires a better hand in violation of the game rules. Sometimes, the cheating is even done by the dealer, who is usually an employee of casino. For example, the dealer may conspire with a player and intentionally commits certain technical faults in dealing the cards. As a general practice, if a round of dealing of cards is faulty, the players of the round can challenge it and may be able to set aside the result of the round. The secret knowledge that a technical fault is committed gives the player an illegitimate advantage that she may be willing to place a big bet because she knows that once she loses, she can challenge the round and has a good chance to successfully set aside the result. These are the forms of cheating that the traditional dealing shoe is not capable of remedying.

[0010] A conventional solution to the aforementioned issues can be found in U.S. Pat. No. 6,582,301 (hereinafter as "the '301 patent") entitled as "System Including Card Game Dispensing Shoe With Barrier And Scanner, And Enhanced Card Gaming Table Enabling Waging By Remote Bettors." The patent discloses a game monitoring and display device for a card game, which comprises a shoe including a housing having an outlet slot, and a scanner disposed in the housing to scan each card dispensed through the outlet slot and to generate a scanner signal representative of identity of each card.

[0011] Although the '301 patent provides a scanner to the card dealing shoe to scan the cards and therefore allowing a player to participate a card game remotely, it has some drawbacks. The scanner is disposed in the housing of card dealing shoe, so that there is a chance that the card received in the housing would be scanned by the scanner, either accidentally or intentionally. The dealer may have a chance

to know the values of the cards before they are dealt out of the card dealing shoe. As a result, there is a light risk of cheating with the card dealing shoe. In order to get the value of the cards, the scanner scans the image first to generate image signals and some circuitry provided within the card dealing shoe processes the image signals for recognition of the values they represent. The image recognition process is time-consuming and computing-resource-demanding. Further, it is not unusual that the results of the image recognition would be incorrect.

[0012] In addition to reducing the risk of cheating, the casino may want to collect as much information as possible for card games. Because a card game is basically gambling on probability, by collecting the information the card game for analytical and managerial purposes, the casino may be able to better understand the profitability of the tables on which the card games are played. The collected information also helps the casino to early identify unusually happenings that may indicate managerial problems.

[0013] Thus, what is needed is an apparatus and system that is capable of identifying the values of the card dealt in a card game for further processing for management purposes and preventing cheating.

SUMMARY OF THE PRESENT INVENTION

[0014] An objective of the present invention is to provide a poker dealing device for dispensing playing cards, wherein the poker dealing device is capable of automatically reading the value of the playing card that is being dispensed through a dispensing slot of the poker dealing device in order to prevent cheating in a card game.

[0015] An another objective of the present invention is to provide a poker dealing device for dispensing special playing cards having card indicators representing the values of playing card, so as to ease the recognition process for the playing cards when the playing card is being dispensed through a dispensing slot of the poker dealing device.

[0016] Another objective of the present invention is to provide a poker dealing device for dispensing playing cards, wherein the poker dealing device is capable of automatically reading the value of the playing card that is being dispensed through a dispensing slot of the poker dealing device for further processing for management purposes.

[0017] Another objective of the present invention is to provide a poker dealing device for dispensing playing cards, wherein the poker dealing device is capable of automatically reading the value of the playing card that is being dispensed through a dispensing slot and transmitting signals representing the values of the playing cards dispensed to a remote location for further processing for management purposes.

[0018] Another objective of the invention is to provide a card dealing system comprising a central management unit in association with the previously mentioned poker dealing device for recoding and processing the values of the playing cards dispensed for prevention of cheating and better management.

[0019] Another objective of the invention is to provide a card dealing system comprising a poker table and card dealing system in association with the previously mentioned

poker dealing device for determining the winners and losers and calculating odds and rewards for each player in a card game.

[0020] Accordingly, in order to accomplish the above objects, the present invention provides a poker dealing device for dispensing playing cards, each having a face side and a card value provided thereon, wherein the poker dealing device comprises:

[0021] a housing having a receiving cavity for receiving the playing cards, and a dispensing slot communicating with the receiving cavity for allowing the playing cards to be dispensed therethrough in a one-by-one manner; and

[0022] a card reader provided at the dispensing slot at a position out of the receiving cavity for reading the card value of said playing card at a time when the playing card is dispensed out of the receiving cavity through the dispensing slot, so as to guarantee said card values of the playing cards in the receiving cavity in a secrete manner until the playing cards are dispensed out of the receiving cavity through the dispensing slot.

[0023] In addition, the present invention also discloses a card dealing system for management and regulation of a card game, comprising: the poker dealing device; a central management for generating a game record regarding the playing cards that have been dealt in the card game, and communication means for communicatively transmitting the card signal from the card reading device to the central management unit in such a manner that the game record is generated at the central management unit based on the card signal read from the card reader with respect to the playing cards dispensed from the poker dealing device in the card game.

[0024] These and other objectives, features, and advantages of the present invention will become apparent from the following detailed description, the accompanying drawings, and the appended claims.

BRIEF DESCRIPTION OF THE DRAWINGS

[0025] FIG. 1 is an exemplary illustration of a card dealing system comprising the poker dealing device, according to a preferred embodiment of the present invention.

[0026] FIG. 2 is a functional block diagram of the card dealing system that comprises a poker dealing device, central management unit and poker table, according to the preferred embodiment of the present invention.

[0027] FIG. 3 is a top view of the poker dealing device according to the preferred embodiment of the present invention.

[0028] FIG. 4 is a side view of the poker dealing device according to the preferred embodiment of the present invention.

[0029] FIG. 5 is a perspective view of the poker dealing device according to the preferred embodiment of the present invention.

[0030] FIG. 6 is a top view of an exemplary poker table according to the preferred embodiment of the present invention.

DETAILED DESCRIPTION OF THE
PREFERRED EMBODIMENT

[0031] Referring to FIG. 1, a card dealing system 10 employed in a casino for better managing and regulating a card game, according to one preferred embodiment of the present invention. The card dealing system 10 comprises a poker dealing device 20, a central management unit 30, a computerized device, communication means 40 and a poker table 50.

[0032] Accordingly, the card game is incorporated with at least a deck of playing cards 202 each having a face side and a card value provided thereon. Each deck of playing cards 202 includes four sets of face cards and four sets of numerical value cards. Each set of the face cards includes an Ace, a Jack card, a Queen card, and a King card and each of said numerical value cards includes a 2 card, a 3 card, a 4 card, a 5 card, a 6 card, a 7 card, a 8 card, and a 9 card. The four sets of numerical value cards and the four sets of face cards of each deck can also be identified by different face signs to include a SPADE group set, a HEART group set, a CLUB group set, and a DIAMOND group set or other kinds of signs.

[0033] The poker dealing device 20 is capable of dispensing playing cards to the participants, including the players and dealers, of the card game. The participants sit around the poker table 50, receive playing cards dealt from the dealer and place bets on the poker table 50.

[0034] According to the preferred embodiment, the poker dealing device 20 comprises a housing 201 having a receiving cavity 207 for receiving the playing cards 202, and a dispensing slot 203 communicating with the receiving cavity 207 for allowing the playing cards 202 to be dispensed therethrough in a one-by-one manner.

[0035] The housing 201 further comprises a circuit chamber 209 and a divider 204 inclinedly disposed in the receiving cavity 207 into a card chamber 208 for receiving the playing cards 202 therein. A wedge 205 having a sloped front side 210 is slidably placed on the divider 204 behind the playing cards 202 with respect to the dispensing slot 203. The gravity of the wedge 205 and slope of the divider 204 pushes the playing cards 202 against the dispensing slot 203, so as to allow the playing cards being dispensed through the dispensing slot 203 in a one-by-one manner, as shown in FIGS. 3 and 4.

[0036] The poker dealing device 20 further comprises a card reading device comprising a card reader 21 provided at the dispensing slot 203 at a position out of the receiving cavity 207 for reading the card value of the playing card 202 at a time when the playing card 202 is dispensed out of the receiving cavity 207 through the dispensing slot 203, so as to guarantee the card values of the playing cards 202 in the receiving cavity 207 in a secrete manner until the playing cards 202 are dispensed out of the receiving cavity 207 through the dispensing slot 203.

[0037] Referring to FIG. 5, the card reader 21 is disposed out of the receiving cavity 207 at the front line of dispensing slot 203, wherein the card reader 21 is activated only when a playing card 202 moves thereacross. The playing cards 202 are dispensed with their faces facing down. This arrangement allows the card reader 21 to read the playing card 202 that is dispensing through the dispensing slot 203, and the

playing cards 202 stored in the card chamber 208 remains secret. As a result, the chance of cheating by a dealer or casino personnel stealthily learns the values of cards received in the receiving cavity 207 with the card reader 21. As an alternative, the card reader 21' may be place at two front sides of dispensing slot 203, wherein the card reader 21' is also activated only when a playing card 202 moves thereacross.

[0038] The card reading device further comprises an electric circuitry 206 supported within the circuit chamber 209 of the housing 201 to electrically connect with the card reader 21 for communicating with the computerized device. The electric circuitry 206 comprises a digital encoder 22 encoding a card signal read from the card reader 21 in a digital form and a signal transmitter 24 electrically connected to the digital encoder 22 for transmitting the card signal to the computerized device.

[0039] The arrangement of card reader 21 makes sure that only the playing cards that have already been dealt would be read and understood. Thus, there is no risk that the dealer would know the values and suits of all playing cards stored in the card chamber 208 before they are dispensed, so that the public can be sure that the dealer cannot cheat via the card reader 21. Moreover, the poker dealing device 20 is so programmed that the card signals representing the values of the playing cards that are already dealt would not be transmitted until all the cards are dealt for a card game when no one can gain illegitimate advantages by intercepting the transmitted card signals. As a result, the disclosed poker dealing device 20 is able to gain the public's faith in the fairness of card games and eventually make a contribution to the casino's success.

[0040] According to preferred embodiment, the card reader 21 is used in association with a card indicator disposed in association with the playing cards 202 for facilitating the card reading of the card reader 21. The card indicator is adapted for forming at the face side of each of the playing cards 202 to represent the card value thereof, wherein the card indicator is positioned aligning with the card reader 21 such that the card reader 21 reads the card indicator when the respective playing card 202 is dispensed out of the receiving cavity 207 through the dispensing slot 203.

[0041] Two solutions are provided for the card indicators. According to one solution, the card indicators are embodied as a set of barcode indicators, each of which represents the value and suit of its respective playing card 202. The card indicator comprises a barcode 210 adapted for printing on the face side of each of the playing cards 202 to represent the card value thereof, wherein the card reader 21 is an optical scanning device reading the barcode 210 of the card indicator on each of the playing cards 202.

[0042] Each barcode 210 is attached on the face side of its respective playing card 202. When the playing card 202 moves across the card reader 21, it projects a beam to the barcode 210 of the card indicator and receives the reflection of the beam to generate the analog card signal representing the value and suit of the playing card 202.

[0043] According to another solution, the card reader 21 communicates with the card indicators by means of magnetic communication, each of which represents the value

and suit of its respective playing card. The card indicator comprises a magnetic-sensitive layer **211** adapted for attaching on the face side of each of the playing cards **202** to represent the card value thereof, wherein the card reader **21** is a magnetic-sensor reading the magnetic-sensitive layer **211** of the card indicator on each of the playing cards **202**.

[**0044**] Each magnetic-sensitive layer **211** is disposed between a face layer and a back layer of its respective playing card. When the playing card **202** moves across the card reader **21**, it identifies the value and suit represented by the magnetic-sensitive layer **211** to generate the analog card signal representing the value and suit of the playing card.

[**0045**] The card indicators ease the process of card reading by avoiding excessive imaging processing. Otherwise, the card reader **21** would have had to catch the whole image data of playing card, and analyze the image data to know what the value and suit of the playing card are. Thus, the card indicators may save the processing time to provide better real-time management, and reduce the manufacturing cost. It is noted that, the card reader **21** can be any traditional image sensor that detects the image of the playing cards **202** to generate image signals for further processing of image recognition.

[**0046**] The digital encoder **22** comprises an analog/digital converter converting the analog card signal into the digital card signal for purposes of quality of signal communication and ease of data processing. The electric circuitry **206** further comprises an amplifier **23** amplifying the digital card signal as an amplified digital card signal that is more recognizable for a circuitry, and therefore promoting the convenience of signal communication and data processing. The amplified digital card signal has the advantages of less susceptible to noise than an analog signal in the course of signal communication, and compatible for calculation of processors.

[**0047**] The signal transmitter **24** transmits the amplified digital card signal to a remote location, where the central management unit **30** locates at the computerized device, for further data processing. The transmission of the amplified digital card signal is in the form of either infrared signal or radio frequency. It is noted that the signal transmitter **24** may transmit the amplified digital card signal by means of wire connection.

[**0048**] Accordingly, the signal transmitter **24** is an infrared transmitting device adapted for sending the card signal as an infrared signal to the computerized device, such that the signal transmitter **24** functions as a wireless communication link for wirelessly communicating the card reading device with the computerized device.

[**0049**] Alternatively, the signal transmitter **24** is a radio frequency transmitting device adapted for sending the card signal as a radio frequency to the computerized device, such that the signal transmitter **24** functions as a wireless communication link for wirelessly communicating the card reading device with the computerized device.

[**0050**] The communication means **40** is arranged for communicatively transmitting the card signal from the card reading device to the central management unit **30** in such a manner that a game record is generated at the central management unit **30** based on the card signal read from the

card reader **21** with respect to the playing cards **202** dispensed from the poker dealing device **20** in the card game.

[**0051**] The communication means **40** comprises a signal receiver **41** receiving the card signal from the poker dealing device **20** wherein the signal receiver **41** is linked to the central management unit **30** such that the card signal sent from the poker dealing device **20** is sent to the central management unit **30** through the communication means **40**. In other words, the communication means **40** is capable of receiving signals from the poker dealing device **20** and transmitting the same to the central management unit **30** so as to extend the communication range of the central management unit **30** and the poker dealing device **20**.

[**0052**] According to the preferred embodiment, the signal receiver **41** is affixed on the roof of a game room hosting the poker table **50** and poker dealing device **20**, as shown in **FIG. 1**. The signal receiver **41'** can also be placed on the ground of the game room as an alternative of the preferred embodiment.

[**0053**] Accordingly, the signal receiver **41** is embodied as an infrared receiver linked with the central management unit **30**, such that the signal transmitter **24** functions as a wireless communication link between the card reading device and the central management unit **30** through the signal receiver **41** of the communication means **40**.

[**0054**] Alternatively, the signal receiver **41** is a radio frequency receiver linked with the central management unit **30**, such that the signal transmitter **24** functions as a wireless communication link between the card reading device and the central management unit **30** through the signal receiver **41** of the communication means **40**. It is worth to mention that the communication means **40** can be a set of wires connecting the above-mentioned elements together instead of wireless communication.

[**0055**] The central management unit **30** is arranged for generating the game record regarding the playing cards **202** that have been dealt in the card game. The central management unit **30** comprises a signal receiving link **31**, a central processing unit **32**, data storage medium **33**, a result display **34** and a control panel **35**. The signal receiving link **31** receives the amplified digital data signal transmitted from the signal transmitter **24** through the signal receiver **41** of the communication means **40**, and forwards the signal to the central processing unit **32**, which responds to the amplified digital card signal to perform several functions. Accordingly, a game rule is preloaded in the central processing unit **32** such that the card signal is input into the central processing unit to generate the game record regarding the playing cards **202** that have been dealt in the card game.

[**0056**] The information related to the playing cards is recorded in the data storage medium **23**, wherein the records comprise the value and suit of each playing card dealt from the poker dealing device **20**, the order of card, the relationship of the card in association with other cards for making up a hand for a particular round of card game, and status of winning and losing for a round of card game.

[**0057**] According to the preferred embodiment, the result display **34** displays the game record regarding the status of winning and losing and odds after the round of card game is over. The result display **34**, which is linked to the central processing unit **32**, selectively shows the records of infor-

mation regarding the playing cards **202** on a screen according to a predetermined program that is performed by the central processing unit **32**.

[0058] The control panel **35** receives input commands of handling the records regarding the value and suit of each playing card dealt from the poker dealing device **20**, the order of card, the relationship of the card in association with other cards for making up a hand for a particular round of card game, and status of winning and losing for a round of card game. Some input commands may be converted into digital command signals, which are transmitted by the signal receiving link **31** to a remote place where the card game under the monitor of the central management unit **30** is going on, so that the dealer may take certain actions to improve or remedy the card game according to the input commands.

[0059] The association of the poker dealing device **20** with the central management unit **30** provides certain advantages. Because the value and suit of each playing card **202** that has been dispensed from the poker dealing device **20** is known by the central management unit **30**, the chance of cheating by secretly switching the playing card **202** is reduced. The records preserved in the data storage medium **33** provides trusted history of every card games as a basis for challenges by the players. This reduces the chance of cheating that the dealer and players conspire to challenge the card games in order to invalidate results of card games. Because the fairness of card games is one of the most important factors contributing to public's faith on the games, the present invention helps to build up public's faith and therefore contributing to the success of a casino that adopts the card dealing system.

[0060] As shown in FIGS. 1 and 6, the poker table **50** comprises a tabletop **502** having a top surface **506** for dealing the playing cards **202** and placing bets, and supporting member **501** for structurally supporting the tabletop **506**, wherein a plurality of betting areas **503** are provided on the tabletop **502** restricting a bet within one of the betting areas **503**.

[0061] Accordingly, the bet sensor **51** detects the bets placed by players and dealer to generate analog bet signals representing the values of the placed bets, as shown in FIG. 2. In this preferred embodiment, the bet sensor **51** detects the weight of chips wagered to generate the analog bet signal representing the value of the placed bet. It is noted that other solutions may be adopted for the bet sensor **51** to detect the value of the placed bets. For example, the bet sensor **51** may detect the magnetic or optical-sensitive indicators provided for chips wagered to generate the analog bet signal representing the value of the placed bet. In other words, the bet sensors **51** are disposed in association with the betting areas **503** for detecting the placed bets to generate the bet signal representing the values of placed bets. In addition, a concave portion **504** is formed on the top surface **506** of tabletop **502** for receiving chips, which may be implemented with optical-sensitive or magnetic indicators for facilitating the bet sensors **51** to read the values of placed bets.

[0062] As mentioned above, the bet sensors can simply be weight sensors that detect the weight of the chips to determine the value of the placed bets. A game display **55** is provided on the top surface **506** of tabletop **502** for showing information generated by the poker table **50** and received from the central management unit **30**.

[0063] The poker table **50** further comprises a second digital encoder **52**, a signal processor **53**, a control unit **54**, game display **55**, and a second signal transmitter **56**.

[0064] The second digital encoder **52** is embodied as an analog/digital converter converting the analog bet signal into a digital bet signal for convenience of signal communication and data processing. Accordingly, the second digital encoder **52** can be embodied as the digital encoder **22** of the poker dealing device **20** such that the bet sensor **51** is electrically linked to the digital encoder **22** of the poker dealing device **20** to encode the bet signal into the digital form.

[0065] The signal processor **53** responds to the digital bet signal to generate a bet management signal representing information that includes status of winning and losing, odds, and rewards for the placed bet. The game display **55** is adaptive to selectively display the bet management signal, and the control unit **54** is adaptive to receive input commands to direct the signal processor **53** in handling the bet management signal. The second signal transmitter **56** is adaptive to transmit the bet management signal to and receive a control signal from the central management unit **30** through the communication means **40** so that the central management unit **30** and dealer can communicate real-time in the course of the card game.

[0066] For example, the central processing unit **32** of central management unit **30** may include a program that calculates the odds and monetary results for winning and losing parties of the card games, and the calculated results may be transmitted from the signal receiving link **31** to the second signal transmitter **56** and displayed on the game display **55**. Thus, the risk of miscalculating of the odds and winning or losing results by the dealer would be reduced. It is worth to mention that the second transmitter **56** can be embodied as the signal transmitter **24** of the poker dealing device **20** such that the bet sensor **51** is electrically linked with the signal transmitter **24** of the poker dealing device **20** to transmit the bet signal to the central management unit **30** so as to minimize the component of the present invention.

[0067] In view of the foregoing description, the disclosed poker dealing device has the following advantages. First, the poker dealing device is capable reading the value and suit of a play card that is dispensing through its dispensing slot, so that a record tracking the dealt playing card is therefore available. This reduces the chance of cheating and promotes the public's faith on the card games that adopt the disclosed poker dealing device. Furthermore, the poker dealing device may be used in association with a deck of special playing cards, wherein each playing card has a card indicator representing its value and suit so as to ease the processing of the recognition of cards. The central management unit and poker table make enhanced managerial functions possible, wherein the calculation of status of winning and losing, odds, rewards and placed bets can be done accurately by the central management unit and the related information can be provided to the dealer immediately. Thus, the disclosed card dealing system greatly helps the success of casinos' business.

[0068] One skilled in the art will understand that the embodiment of the present invention as shown in the drawings and described above is exemplary only and not intended to be limiting.

[0069] It will thus be seen that the objects of the present invention have been fully and effectively accomplished. It

embodiments have been shown and described for the purposes of illustrating the functional and structural principles of the present invention and is subject to change without departure from such principles. Therefore, this invention includes all modifications encompassed within the spirit and scope of the following claims.

What is claimed is:

1. A poker dealing device for dispensing playing cards, each having a face side and a card value provided thereon, wherein said poker dealing device comprises:

a housing having a receiving cavity for receiving said playing cards, and a dispensing slot communicating with said receiving cavity for allowing said playing cards to be dispensed therethrough in a one-by-one manner; and

a card reading device comprising a card reader provided at said dispensing slot at a position out of said receiving cavity for reading said card value of said playing card at a time when said playing card is dispensed out of said receiving cavity through said dispensing slot, so as to guarantee said card values of said playing cards in said receiving cavity in a secrete manner until said playing cards are dispensed out of said receiving cavity through said dispensing slot.

2. The poker dealing device, as recited in claim 1, further comprising a card indicator adapted for forming at said face side of each of said playing cards to represent said card value thereof, wherein said card indicator is positioned aligning with said card reader such that said card reader reads said card indicator when said respective playing card is dispensed out of said receiving cavity through said dispensing slot.

3. The poker dealing device, as recited in claim 2, wherein said card indicator comprises a barcode adapted for printing on said face side of each of said playing cards to represent said card value thereof, wherein said card reader is an optical scanning device reading said barcode of said card indicator on each of said playing cards.

4. The poker dealing device, as recited in claim 2, wherein said card indicator comprises a magnetic-sensitive layer adapted for attaching on said face side of each of said playing cards to represent said card value thereof, wherein said card reader is a magnetic-sensor reading said magnetic-sensitive layer of said card indicator on each of said playing cards.

5. The poker dealing device, as recited in claim 1, wherein said housing further comprising a divider inclinedly supported in said receiving cavity to divide said receiving cavity into a circuit chamber and a card chamber for receiving said playing cards therein, wherein said card reading device further comprises an electric circuitry supported within said circuit chamber to electrically connect with said card reader for communicating with a computerized device.

6. The poker dealing device, as recited in claim 3, wherein said housing further comprising a divider inclinedly supported in said receiving cavity to divide said receiving cavity into a circuit chamber and a card chamber for receiving said playing cards therein, wherein said card reading device further comprises an electric circuitry supported within said circuit chamber to electrically connect with said card reader for communicating with a computerized device.

7. The poker dealing device, as recited in claim 5, wherein said electric circuitry comprises a digital encoder encoding

a card signal read from said card reader in a digital form and a signal transmitter electrically connected to said digital encoder for transmitting said card signal to said computerized device.

8. The poker dealing device, as recited in claim 6, wherein said electric circuitry comprises a digital encoder encoding a card signal read from said card reader in a digital form and a signal transmitter electrically connected to said digital encoder for transmitting said card signal to said computerized device.

9. The poker dealing device, as recited in claim 7, wherein said signal transmitter is an infrared transmitting device adapted for sending said card signal as an infrared signal to said computerized device, such that said signal transmitter functions as a wireless communication link for wirelessly communicating said card reading device with said computerized device.

10. The poker dealing device, as recited in claim 8, wherein said signal transmitter is an infrared transmitting device adapted for sending said card signal as an infrared signal to said computerized device, such that said signal transmitter functions as a wireless communication link for wirelessly communicating said card reading device with said computerized device.

11. The poker dealing device, as recited in claim 7, wherein said signal transmitter is a radio frequency transmitting device adapted for sending said card signal as a radio frequency to said computerized device, such that said signal transmitter functions as a wireless communication link for wirelessly communicating said card reading device with said computerized device.

12. The poker dealing device, as recited in claim 8, wherein said signal transmitter is a radio frequency transmitting device adapted for sending said card signal as a radio frequency to said computerized device, such that said signal transmitter functions as a wireless communication link for wirelessly communicating said card reading device with said computerized device.

13. A card dealing system for management and regulation of a card game incorporating with a plurality of playing cards each having a face side and a card value provided thereon, wherein said card dealing system comprises:

a poker dealing device, comprising:

a housing having a receiving cavity for receiving said playing cards and a dispensing slot communicating with said receiving cavity for allowing said playing cards to be dispensed therethrough in a one-by-one manner; and

a card reading device comprising a card reader provided at said dispensing slot at a position out of said receiving cavity for reading said card value of said playing card to generate a card signal at a time when said playing card is dispensed out of said receiving cavity through said dispensing slot, so as to guarantee said card values of said playing cards in said receiving cavity in a secrete manner until said playing cards are dispensed out of said receiving cavity through said dispensing slot;

a central management unit for generating a game record regarding said playing cards that have been dealt in said card game; and

communication means for communicatively transmitting said card signal from said card reading device to said central management unit in such a manner that said game record is generated at said central management unit based on said card signal read from said card reader with respect to said playing cards dispensed from said poker dealing device in said card game.

14. The card dealing system, as recited in claim 13, further comprising a card indicator adapted for forming at said face side of each of said playing cards to represent said card value thereof, wherein said card indicator is positioned aligning with said card reader such that said card reader reads said card indicator when said respective playing card is dispensed out of said receiving cavity through said dispensing slot.

15. The card dealing system, as recited in claim 13, wherein said card reading device further comprises a digital encoder which is supported within said receiving cavity and electrically connected with said card reader to encode said card signal therefrom, and a signal transmitter electrically connected to said digital encoder to transmit said card signal to said central management unit through said communication means.

16. The card dealing system, as recited in claim 15, wherein said signal transmitter is an infrared transmitting device adapted to sending said card signal as an infrared signal to said central management unit, and said communication means comprises an infrared receiver linked with said central management unit, such that said signal transmitter functions as a wireless communication link between said card reading device and said central management unit through said infrared receiver.

17. The card dealing system, as recited in claim 15, wherein said signal transmitter is a radio frequency transmitting device adapted for sending said card signal as a radio frequency to said central management unit, and said communication means comprises a radio frequency receiver linked with said central management unit, such that said signal transmitter functions as a wireless communication link between said card reading device and said central management unit through said radio frequency receiver.

18. The card dealing system, as recited in claim 16, wherein said housing further comprising a divider inclinedly supported in said receiving cavity to divide said receiving cavity into a circuit chamber for said signal transmitter receiving therein and a card chamber for receiving said playing cards therein.

19. The card dealing system, as recited in claim 17, wherein said housing further comprising a divider inclinedly supported in said receiving cavity to divide said receiving cavity into a circuit chamber for said signal transmitter receiving therein and a card chamber for receiving said playing cards therein.

20. The card dealing system, as recited in claim 13, wherein said central management unit comprises a central processing unit responsive to said card signal to generate said game record regarding said card values of said playing cards dispensed from said poker dealing device and status of winning and losing and odds for said card game.

21. The card dealing system, as recited in claim 15, wherein said central management unit comprises a central

processing unit responsive to said card signal to generate said game record regarding said card values of said playing cards dispensed from said poker dealing device and status of winning and losing and odds for said card game.

22. The card dealing system, as recited in claim 20, wherein said central management unit further comprises a result display displaying said game record regarding said status of winning and losing and odds after said card game is over.

23. The card dealing system, as recited in claim 21, wherein said central management unit further comprises a result display displaying said game record regarding said status of winning and losing and odds after said card game is over.

24. The card dealing system, as recited in claim 13, further comprising a poker table for hosting said card game, wherein said poker table comprises a tabletop defining a betting area for restricting a bet therewithin, and a bet sensor disposed in association with said betting area for detecting said bet therewith to generate a bet signal representing a value of said bet, wherein said bet signal is transmitted to said central management unit such that said game record is generated at said central management unit based on said bet signal corresponding to said card signal.

25. The card dealing system, as recited in claim 15, further comprising a poker table for hosting said card game, wherein said poker table comprises a tabletop defining a betting area for restricting a bet therewithin, and a bet sensor disposed in association with said betting area for detecting said bet therewith to generate a bet signal representing a value of said bet, wherein said bet signal is transmitted to said central management unit such that said game record is generated at said central management unit based on said bet signal corresponding to said card signal.

26. The card dealing system, as recited in claim 21, further comprising a poker table for hosting said card game, wherein said poker table comprises a tabletop defining a betting area for restricting a bet therewithin, and a bet sensor disposed in association with said betting area for detecting said bet therewith to generate a bet signal representing a value of said bet, wherein said bet signal is transmitted to said central management unit such that said game record is generated at said central management unit based on said bet signal corresponding to said card signal.

27. The card dealing system, as recited in claim 24, wherein said bet sensor detects a weight of chips as said bet placed within said betting area to generate said bet signal representing said value of said chips.

28. The card dealing system, as recited in claim 25, wherein said bet sensor detects a weight of chips as said bet placed within said betting area to generate said bet signal representing said value of said chips.

29. The card dealing system, as recited in claim 26, wherein said bet sensor detects a weight of chips as said bet placed within said betting area to generate said bet signal representing said value of said chips.