



(86) Date de dépôt PCT/PCT Filing Date: 2014/03/14  
(87) Date publication PCT/PCT Publication Date: 2014/09/18  
(45) Date de délivrance/Issue Date: 2021/06/22  
(85) Entrée phase nationale/National Entry: 2015/08/10  
(86) N° demande PCT/PCT Application No.: US 2014/028750  
(87) N° publication PCT/PCT Publication No.: 2014/144370  
(30) Priorité/Priority: 2013/03/15 (US61/802,113)

(51) Cl.Int./Int.Cl. *A61L 27/36* (2006.01),  
*A61L 27/50* (2006.01)  
(72) Inventeurs/Inventors:  
CHUTKA, MICHELLE, US;  
HILES, MICHAEL C., US  
(73) Propriétaire/Owner:  
COOK BIOTECH INCORPORATED, US  
(74) Agent: KIRBY EADES GALE BAKER

(54) Titre : COMPOSITIONS D'IMPLANT ECM ET PROCEDES  
(54) Title: ECM IMPLANT COMPOSITIONS AND METHODS

(57) **Abrégé/Abstract:**

Described our medical compositions and methods including a particulate extracellular matrix tissue in admixture with sugar. Such medical compositions, dried forms, can demonstrate enhanced rehydration properties. Medical compositions and products as described herein find particular use in treating diseased and/or damaged tissue, such as wound repair. Related methods of manufacture and use are also described.

(12) INTERNATIONAL APPLICATION PUBLISHED UNDER THE PATENT COOPERATION TREATY (PCT)

(19) World Intellectual Property  
Organization  
International Bureau(10) International Publication Number  
**WO 2014/144370 A1**(43) International Publication Date  
18 September 2014 (18.09.2014)

WIPO | PCT

- (51) International Patent Classification:  
*A61L 27/36* (2006.01) *A61L 27/50* (2006.01)
- (21) International Application Number:  
PCT/US2014/028750
- (22) International Filing Date:  
14 March 2014 (14.03.2014)
- (25) Filing Language: English
- (26) Publication Language: English
- (30) Priority Data:  
61/802,113 15 March 2013 (15.03.2013) US
- (71) Applicant: **COOK BIOTECH INCORPORATED**  
[US/US]; 1425 Innovation Place, West Lafayette, IN  
47906 (US).
- (72) Inventors: **CHUTKA, Michelle**; 2113 Marconi Court,  
West Lafayette, IN 47906 (US). **HILES, Michael C.**; 4326  
South 900 East, West Lafayette, IN 47905 (US).
- (74) Agents: **GANDY, Kenneth A.** et al.; Woodard, Emhardt,  
Moriarty, Mcnett & Henry LLP, 111 Monument Circle,  
Suite 3700, Indianapolis, IN 46204 (US).
- (81) Designated States (*unless otherwise indicated, for every  
kind of national protection available*): AE, AG, AL, AM,  
AO, AT, AU, AZ, BA, BB, BG, BH, BN, BR, BW, BY,  
BZ, CA, CH, CL, CN, CO, CR, CU, CZ, DE, DK, DM,

DO, DZ, EC, EE, EG, ES, FI, GB, GD, GE, GH, GM, GT,  
HN, HR, HU, ID, IL, IN, IR, IS, JP, KE, KG, KN, KP, KR,  
KZ, LA, LC, LK, LR, LS, LT, LU, LY, MA, MD, ME,  
MG, MK, MN, MW, MX, MY, MZ, NA, NG, NI, NO, NZ,  
OM, PA, PE, PG, PH, PL, PT, QA, RO, RS, RU, RW, SA,  
SC, SD, SE, SG, SK, SL, SM, ST, SV, SY, TH, TJ, TM,  
TN, TR, TT, TZ, UA, UG, US, UZ, VC, VN, ZA, ZM,  
ZW.

- (84) Designated States (*unless otherwise indicated, for every  
kind of regional protection available*): ARIPO (BW, GH,  
GM, KE, LR, LS, MW, MZ, NA, RW, SD, SL, SZ, TZ,  
UG, ZM, ZW), Eurasian (AM, AZ, BY, KG, KZ, RU, TJ,  
TM), European (AL, AT, BE, BG, CH, CY, CZ, DE, DK,  
EE, ES, FI, FR, GB, GR, HR, HU, IE, IS, IT, LT, LU, LV,  
MC, MK, MT, NL, NO, PL, PT, RO, RS, SE, SI, SK, SM,  
TR), OAPI (BF, BJ, CF, CG, CI, CM, GA, GN, GQ, GW,  
KM, ML, MR, NE, SN, TD, TG).

**Declarations under Rule 4.17:**

- *as to applicant's entitlement to apply for and be granted a  
patent (Rule 4.17(ii))*
- *as to the applicant's entitlement to claim the priority of the  
earlier application (Rule 4.17(iii))*

**Published:**

- *with international search report (Art. 21(3))*



WO 2014/144370 A1

(54) Title: ECM IMPLANT COMPOSITIONS AND METHODS

(57) Abstract: Described our medical compositions and methods including a particulate extracellular matrix tissue in admixture with sugar. Such medical compositions, dried forms, can demonstrate enhanced rehydration properties. Medical compositions and products as described herein find particular use in treating diseased and/or damaged tissue, such as wound repair. Related methods of manufacture and use are also described.

## ECM IMPLANT COMPOSITIONS AND METHODS

### REFERENCE TO RELATED APPLICATIONS

The present application claims the benefit of U.S. Provisional Patent  
5 Application Ser. No. 61/802,113 filed March 15, 2013 entitled ECM IMPLANT  
COMPOSITIONS AND METHODS.

### BACKGROUND

The present invention resides generally in the field of medical  
10 compositions and in particular aspects to medical compositions that incorporate  
extracellular matrix materials.

As further background, a variety of extracellular matrix (ECM) materials  
have been proposed for use in medical grafting, cell culture, and other related  
applications. For instance, medical grafts and cell culture materials containing  
15 submucosa derived from small intestine, stomach, or urinary bladder tissues, have  
been proposed. *See, e.g.* U.S. Pat. Nos. 4,902,508, 4,956,178, 5,281,422,  
5,554,389, 6,099,567 and 6,206,931. Medical materials derived from liver  
basement membrane have also been proposed, for example in U.S. Pat. No.  
6,379,710. As well, ECM materials derived from amnion (*see e.g.* U.S. Pat. Nos.  
20 4,361,552 and 6,576,618) and from renal capsule membrane (*see* International  
PCT Patent Application No. WO/03/002165 published Jan. 9, 2003) have been  
proposed for medical and/or cell culture applications. In addition, Cook Biotech  
Incorporated, West Lafayette, Indiana, currently manufactures a variety of medical  
products based upon small intestinal submucosa under the trademarks  
25 SURGISIS®, STRATASIS® and OASIS®.

In certain applications, medical materials have been formed into fluidized  
compositions and used in conjunction with a variety of components directed  
towards treating a particular condition. For example, U.S. Pat. No. 6,206,931  
describes forming a fluidized composition from an extracellular matrix material.  
30 Such fluidized compositions are typically formed into gels for use as an injectable  
graft. Similarly, International PCT Application No. WO 05/020847 discloses an  
ECM material formed as a gel and including a bioactive component, such as FGF-

2. This gel material can also include a particulate ECM material, which is suggested to provide additional material that can function to provide bioactivity to the gel and/or serve as scaffolding material for tissue ingrowth.

5 A need remains for additional medical compositions and products that can be used in a wide variety of medical applications. The present invention provides such medical compositions and products, as well as methods for preparing and using the same.

## SUMMARY

In certain aspects, the present disclosure pertains to formable medical compositions that include a particulate ECM tissue material. The formable composition may for example be a shape retaining but formable putty material.

Some embodiments herein provide a medical composition including a particulate of a collagenous extracellular matrix (ECM) material, where the composition has enhanced rehydration properties. In accordance with some forms of the disclosure, such medical compositions comprise a particulate ECM tissue and a sugar, preferably fructose. The compositions are in dry form, but are wettable with an aqueous medium, and the compositions may be in the form of a dried porous body. Such wetting, with an appropriate amount of the aqueous medium, can form a shape retaining but formable putty material. Such a putty material can include particles of the particulate ECM tissue bound in slidable relation with one another by an aqueous solution of the fructose and/or other sugar

Other embodiments of the present disclosure provide methods for preparing a material for treatment of diseased or damaged tissue. In one form, the methods comprise drying an admixture of materials including a particulate of comminuted extracellular matrix material, a sugar such as fructose, and a liquid, preferably to form a porous body. The drying step may comprise lyophilization of the admixture.

In other embodiments, the disclosure provides methods of preparing a material for treating diseased or damaged tissue. The methods comprise rehydrating a dried body comprising a particulate ECM tissue and a sugar, preferably fructose. In one form, the rehydrating comprises contacting the dried body with an aqueous medium. The aqueous medium may in some embodiments comprise blood or a blood fraction, including for example serum or platelet-rich plasma. In certain embodiments, the blood or blood fraction may be autologous or allogenic to an intended recipient subject, such as a human subject, for the material. In accordance with certain inventive variants, the method further includes applying the material to diseased or damaged tissue of a recipient subject.

In still further embodiments, the disclosure provides a putty comprising a particulate ECM tissue, a sugar (preferably fructose), and an aqueous medium. The putty is desirably shape retaining but formable. The putty can include particles of the particulate ECM tissue bound in slidable relation with one another by an aqueous solution of the fructose and/or other sugar. The aqueous medium can in some embodiments include blood or a blood fraction, including for example serum or platelet-rich plasma. The blood or blood fraction, when used, may be autologous or allogenic to an intended recipient subject, such as a human subject, for the material.

In accordance with any of the method or product compositions disclosed herein, one or more of the following additional features may be included:

(a) the particulate ECM tissue can include at least one growth factor retained from a source tissue for the particulate ECM tissue;

(b) the method or product is for treatment of diseased and/or damaged tissue, for example a wound or a cutaneous ulcer;

(c) the particulate ECM tissue comprises submucosa, such as intestinal, urinary bladder, stomach, or small intestinal submucosa (SIS);

(d) the method or product can incorporate fructose as the only sugar in the composition, or fructose can be used in combination with one or more other sugars;

(e) the particulate ECM tissue and sugar may be included in any ratio with respect to one another disclosed herein;

(f) a putty material can have any of the ratios or compositional levels of particulate ECM tissue, sugar, and/or aqueous medium disclosed herein.

Additional embodiments, as well as features and advantages of embodiments of the invention, will be apparent from the description herein.

**BRIEF DESCRIPTION OF THE DRAWINGS**

- FIG. 1 is a perspective view of one embodiment of a dried body of the present disclosure.
- 5 FIG. 2 is a perspective view of one embodiment of a dried body of the present disclosure including one form of packing the device.
- FIG. 3 is a graphical representation of rehydration time data per fructose concentration.
- FIG. 4 is a graphical representation of serum uptake data per fructose  
10 concentration.

## DESCRIPTION OF THE SELECTED EMBODIMENTS

For the purposes of promoting an understanding of the principles of the disclosure, reference will now be made to the embodiments illustrated in the drawings and specific language will be used to describe the same. It will  
5 nevertheless be understood that no limitation of the scope of the claims is thereby intended, and alterations and modifications in the illustrated device, and further applications of the principles of the disclosure as illustrated therein are herein contemplated as would normally occur to one skilled in the art to which the  
10 disclosure relates.

As disclosed above, aspects of the present disclosure relate to novel methods and materials for treating diseased or damaged tissue in a patient. In certain aspects, the disclosure relates to materials comprising a particulate ECM tissue and a sugar, preferably fructose. As will be discussed herein, it has been  
15 found that addition of substantial amounts of sugar to a composition including the particulate ECM material results in accelerated rehydration times and increased aqueous medium uptake by the particulate.

The ECM tissue used to prepare the particulate ECM is typically a collagenous material. For example, suitable collagenous ECM materials include  
20 those comprising submucosa, renal capsule membrane, dermal collagen, dura mater, pericardium, fascia lata, serosa, peritoneum or basement membrane layers, including liver basement membrane. These or other ECM materials that occur as connective tissue sheets in soft tissue of the patient, and that can be isolated as such sheets, are preferred. Suitable submucosa-containing ECM materials for  
25 these purposes include, for instance, ECMs including intestinal submucosa (e.g. small intestinal submucosa), stomach submucosa, urinary bladder submucosa, and uterine submucosa. Collagenous ECM materials comprising submucosa (potentially along with other associated tissues) useful in the present invention can be obtained by harvesting such tissue sources and delaminating the submucosa-  
30 containing matrix from smooth muscle layers, mucosal layers, and/or other layers occurring in the tissue source. For additional information as to some of the materials useful in the present invention, and their isolation and treatment,



reference can be made, for example, to U.S. Patent Nos. 4,902,508, 5,554,389, 5,993,844, 6,206,931, and 6,099,567.

Submucosa-containing or other ECM tissue used in the invention is preferably highly purified, for example, as described in U.S. Patent No. 6,206,931 to Cook et al. Thus, preferred ECM material will exhibit an endotoxin level of less than about 12 endotoxin units (EU) per gram, more preferably less than about 5 EU per gram, and most preferably less than about 1 EU per gram. As additional preferences, the submucosa or other ECM material may have a bioburden of less than about 1 colony forming units (CFU) per gram, more preferably less than about 0.5 CFU per gram. Fungus levels are desirably similarly low, for example less than about 1 CFU per gram, more preferably less than about 0.5 CFU per gram. Nucleic acid levels are preferably less than about 5 µg/mg, more preferably less than about 2 µg/mg, and virus levels are preferably less than about 50 plaque forming units (PFU) per gram, more preferably less than about 5 PFU per gram. These and additional properties of submucosa or other ECM tissue taught in U.S. Patent No. 6,206,931 may be characteristic of any ECM tissue used in the present invention.

In some aspects, a typical layer thickness for an isolated submucosa or other ECM connective tissue layer used in the invention ranges from about 50 to about 250 microns when fully hydrated, more typically from about 50 to about 200 microns when fully hydrated, although isolated layers having other thicknesses may also be obtained and used. These layer thicknesses may vary with the type and age of the animal used as the tissue source. As well, these layer thicknesses may vary with the source of the tissue obtained from the animal source.

The ECM tissue layers utilized desirably retain a structural microarchitecture from the source tissue, including structural fiber proteins such as collagen and/or elastin that are non-randomly oriented. Such non-random collagen and/or other structural protein fibers can in certain embodiments provide an ECM tissue that is non-isotropic in regard to tensile strength, thus having a tensile strength in one direction that differs from the tensile strength in at least one other direction. When processed to a particulate ECM tissue, at least some of this structural microarchitecture can remain in the individual particles.

The particulate ECM tissue is advantageously a remodelable material that promotes the formation of new tissue in the patient as the implanted or applied ECM tissue is resorbed. The particulate ECM material can exhibit angiogenic properties and promote cellular invasion and ingrowth.

5           The particulate ECM tissue material may include one or more bioactive factors. Suitable bioactive agents may include one or more bioactive factors native to the source tissue for the ECM tissue. For example, a submucosa or other ECM tissue material may retain one or more native growth factors such as but not limited to basic fibroblast growth factor (FGF-2), transforming growth factor beta  
10 (TGF-beta), epidermal growth factor (EGF), cartilage derived growth factor (CDGF), and/or platelet derived growth factor (PDGF). As well, submucosa or other ECM materials may retain other native bioactive factors such as but not limited to proteins, glycoproteins, proteoglycans, and glycosaminoglycans. For example, ECM materials may include native heparin, heparin sulfate, hyaluronic  
15 acid, fibronectin, cytokines, and the like. Thus, generally speaking, a particulate submucosal or other particulate ECM tissue material may retain one or more bioactive components that induce, directly or indirectly, a cellular response such as a change in cell morphology, proliferation, growth, and protein or gene expression.

          Particulate ECM materials used in the invention will typically include  
20 abundant collagen, most commonly being constituted at least about 80% by weight collagen on a dry weight basis. Naturally-derived ECM materials typically include collagen fibers that are non-randomly oriented, for instance occurring as generally uniaxial or multi-axial but regularly oriented fibers. When processed to retain native bioactive factors, the ECM material can retain these factors interspersed as  
25 solids between, upon and/or within the collagen fibers. Particularly desirable naturally-derived ECM materials for use in the invention will include significant amounts of such interspersed, non-collagenous solids that are readily ascertainable under light microscopic examination with appropriate staining. Such non-collagenous solids can constitute a significant percentage of the dry weight of the  
30 ECM material in certain inventive embodiments, for example at least about 1%, at least about 3%, and at least about 5% by weight in various embodiments of the invention.

Remodelable ECM materials having a relatively more open matrix structure (i.e., higher porosity) are capable of exhibiting different material properties than those having a relatively more closed or collapsed matrix structure. For example, an ECM material having a relatively more open matrix structure is generally softer and more readily compliant to an implant site than one having a relatively more closed matrix structure. Also, the rate and amount of tissue growth in and/or around a remodelable material can be influenced by a number of factors, including the amount of open space available in the material's matrix structure for the infusion and support of a patient's tissue-forming components, such as fibroblasts. Therefore, a more open matrix structure can provide for quicker, and potentially more, growth of patient tissue in and/or around the remodelable material, which in turn, can lead to quicker remodeling of the material by patient tissue.

The particulate ECM material will typically be porous. The porosity of the ECM material can be controlled to some extent by processing techniques. For example the porosity of the ECM material can be reduced by drying the material under compression, for example by drying a starting material ECM layer prior to comminution, or the formed particulate, under compression. On the other hand, an relatively higher porosity ECM material can be prepared by drying the ECM material by lyophilization, for example by freeze drying or evaporative cooling techniques. Such porosity-reducing or porosity-maintaining or porosity-increasing techniques can be used to provide the particulate ECM material with a desired level of porosity for a particular application.

The submucosa-containing or other ECM material used in the present invention may also exhibit an angiogenic character and thus be effective to induce angiogenesis in a host treated with the material. In this regard, angiogenesis is the process through which the body makes new blood vessels to generate increased blood supply to tissues. Thus, angiogenic materials, when contacted with host tissues, promote or encourage the formation of new blood vessels into the materials. Methods for measuring in vivo angiogenesis in response to biomaterial implantation have recently been developed. For example, one such method uses a subcutaneous implant model to determine the angiogenic character of a material. See, C. Heeschen et al., *Nature Medicine* 7 (2001), No. 7, 833-839. When

combined with a fluorescence microangiography technique, this model can provide both quantitative and qualitative measures of angiogenesis into biomaterials. C. Johnson et al., *Circulation Research* 94 (2004), No. 2, 262-268.

Further, in addition or as an alternative to the inclusion of such native  
5 bioactive components, non-native bioactive components such as those synthetically produced by recombinant technology or other methods (e.g., genetic material such as DNA), may be incorporated into an ECM material. These non-native bioactive components may be naturally-derived or recombinantly produced proteins that correspond to those natively occurring in an ECM tissue, but perhaps of a different  
10 species. These non-native bioactive components may also be drug substances. Illustrative drug substances that may be added to materials include, for example, anti-clotting agents, e.g. heparin, antibiotics, anti-inflammatory agents, thrombus-promoting substances such as blood clotting factors, e.g., thrombin, fibrinogen, and the like, and others. Such non-native bioactive components can be incorporated  
15 into and/or onto ECM material in any suitable manner, for example, by surface treatment (e.g., spraying) and/or impregnation (e.g., soaking), just to name a few. Also, these substances may be applied to the ECM material in a premanufacturing step, immediately prior to the procedure, or during or after application of the material to the patient.

20 The particulate ECM material used in aspects herein can be xenogenic, allogenic, or autologous relative to the treated patient. As well, additional materials incorporated in the compositions herein may also be animal-derived, and may be xenogenic, allogenic, or autologous relative to the treated patient. In certain aspects, a human patient will be treated with a composition comprising a  
25 xenogenic particulate ECM tissue (e.g. porcine-, bovine- or ovine-derived) that is combined in the composition with a human material(s) that is/are autologous or allogenic relative to the human patient.

With respect to the particulate, it particulate can be formed by cutting, tearing, grinding or otherwise, comminuting a larger, decellularized ECM  
30 connective tissue layer material as described above to form a particulate. For example, cryogrinding or milling operations can be used to form the particulate ECM tissue material from larger layer. These comminution processes can form

random fragments of the ECM tissue layer. The particle size of the particulate ECM tissue can vary. In preferred aspects, the average particle size of the particulate ECM tissue will be in the range of about 20 microns to about 500 microns, more preferably about 50 microns to about 400 microns. The particulate ECM tissue incorporated into compositions of this disclosure can be an unfractionated particle population prepared by the comminution, or can be a fractions of the particle population prepared by the comminution. Such fractions can for example be obtained by conventional techniques such as screening or sieving.

As disclosed above, compositions of the invention also include a (at least one) sugar. The sugar may, for example, be a simple sugar such as fructose or glucose, or another sugar such as sucrose. These or other monosaccharide or disaccharide sugars are preferred, and fructose is particularly preferred. Such sugars are generally available commercially (including United States Pharmacopeia (USP) grade) as powders, and can be used in that form herein, at least as starting materials or as materials incorporated into dry compositions herein. Fructose is preferred for inclusion in or as the sugar component of the dried compositions or putties herein, and can constitute at least 50% of the sugar, at least 75% of the sugar, at least 90% of the sugar, at least 99% of the sugar, or all or essentially all of the sugar included in the dried composition or putty composition.

The incorporation of a sugar such as fructose in dried compositions disclosed herein can not only improve rehydration rate but can also increase the aqueous medium (e.g. serum, blood, saline, water) uptake of the compositions. Additionally or alternatively, the incorporation of the fructose and/or other sugar can also improve the physical characteristics of the dried composition and of a putty prepared from the dried composition. For example, dried bodies including the sugar and the particulate ECM tissue can be less friable and less prone to contact-initiated surface disintegration than corresponding dried bodies including only the particulate ECM tissue. As well, superior shape retaining but formable putties can result from hydration of a material including the sugar and the

particulate ECM tissue than from hydration of a corresponding material including only the particulate ECM tissue.

To prepare dried compositions herein, the sugar, particulate ECM material, and any other components to be included in the dried composition, can be admixed in any suitable fashion. Illustratively, the materials can be formed into an admixture by dry mixing the particulate ECM material with the sugar and potentially other dry ingredients, or by combining a solution or suspension of one or more of the components with another solution or dry material. Where a dried body composition is to be prepared, the admixed materials, while hydrated with water or another suitable liquid, can be subjected to drying conditions, preferably lyophilization, to form the dried body. This drying can be conducted with the hydrated admixture in a mold or form to result in a regularly shaped dried body that takes on contours imparted by the mold or form. The dried body is desirably porous. According to certain non limiting embodiments, the composite dried body may be spherical, tablet shaped, oblong, or cylindrical. In preferred embodiments, the dried body is shaped as a disc. In some forms, a dried body herein will weigh about 0.5g to 5g. In certain preferred forms, the dried body weighs about 1g to about 3g. Such dried bodies can be formulated to form a shape retaining but formable putty upon hydration with a liquid such as described herein. In some forms the dried body is sterilized. The dried body can thus be sterilely enclosed in a medical package to provide a medical product.

A variety of aqueous media or other materials including biocompatible liquids can be used in the preparation of putty compositions herein. Examples of suitable aqueous mediums include but are not limited to: water, saline, blood or blood fractions, blood serum, platelet rich plasma, serum albumin, bone marrow, bone marrow fractions, cell-containing (including stem-cell containing) preparations isolated from the patient or another subject, and phosphate buffered saline (PBS). Combinations of these mediums with each other or with other suitable liquid mediums may also be used. It will be understood that aqueous or other mediums that can be combined with dried materials herein may include non-liquid components, but will nonetheless include liquid component(s) that will provide the liquid content of the prepared putty compositions as specified herein.

Putty compositions of the invention can include appropriate ratios of particulate ECM tissue, sugar, and liquid to one another, and appropriate overall levels of these components in the putty composition, in order to provide the desired physical properties to the putty. The preferred putty composition is shape retaining, but formable to a new shape by application of force. Still further, the preferred putty can exhibit cohesiveness such that upon deformation the putty does not form cracks but instead flows to a new shape while retaining an intact continuous material matrix. For solid components such as the ECM particulate and sugar, unless indicated otherwise, the ratios and percentages expressed herein are expressed on a dry weight basis.

In certain aspects, the weight ratio of liquid to total solids in the putty is about 3:1 to about 7:1, or about 4:1. Additionally or alternatively, the weight ratio of liquid to particulate ECM tissue in the putty is about 5:1 to about 10:1, or about 6:1. Additionally or alternatively, the weight ratio of particulate ECM tissue to sugar (expressed as total sugars when more than one is included) in the putty can be about 10:1 to about 1:1, about 5:1 to about 1:1, about 3:1 to about 1:1, or about 2:1 (these particulate ECM tissue:sugar weight ratios also apply to dried compositions, e.g. dried bodies, herein).

In respect of overall composition levels of these components, the putty can be constituted about 70% to about 90% by weight of liquid, or about 75% to about 85% of liquid, or about 80% of liquid. Additionally or alternatively, the putty can be constituted about 5% to about 20% by weight of the particulate ECM tissue, or about 10% to about 15% of the particulate ECM tissue, or about 13% of the particulate ECM tissue. Additionally or alternatively, the putty can be constituted about 2% to about 10% by weight of the sugar, or about 5% to about 8%, or about 6% to about 8%.

It will be understood that the putty may include materials other than the liquid, the particulate ECM tissue, and the sugar. In preferred forms, however, the liquid, the particulate ECM tissue, and the sugar, will constitute at least about 70% by weight of the putty, at least about 80% of the putty, at least about 90% of the putty, at least about 95% of the putty, at least about 99% of the putty, or all or essentially all of the weight of the putty, in various embodiments. Additionally or

alternatively, for dried bodies or other dried compositions herein, in preferred  
embodiments, the particulate ECM and the sugar will at least about 70% by weight  
of the dried composition, at least about 80% of the dried composition, at least  
about 90% of the dried composition, at least about 95% of the dried composition,  
5 at least about 99% of the dried composition, or all or essentially all of the weight of  
the dried composition, in various embodiments.

Other materials that may be included in the dried compositions and/or the  
putty composition include, as examples, bioactive components as identified in  
discussions above, sclerosants such as sodium tetradecyl sulfate, additional  
10 scaffolding and/or bioactive materials including for example bone particles,  
demineralized bone matrix particles, calcium phosphate particles, ceramic  
particles, cells (including but not limited to stem cells), osteogenic particles or  
other substances, and others. These materials may be included in the putty in any  
suitable fashion, for example either as materials within dried compositions to be  
15 rehydrated, or as materials dissolved or suspended in rehydrating mediums, or as  
materials added separately to a formed putty.

In some forms, the present disclosure relates to compositions as discussed  
above that have been sterilized or methods which include sterilizing such a  
composition. Sterilization may be conducted in any suitable manner, including for  
20 example ethylene oxide sterilization and/or irradiative sterilization, e.g. gamma ray  
or electron beam sterilization.

The discussions below refer to embodiments depicted in the Figures. It will  
be understood that these specific disclosed embodiments can include any of the  
compositional or technique features disclosed hereinabove, and similarly that the  
25 compositions and methods disclosed above can include any feature depicted in the  
Figures or specifically described in conjunction with the Figures.

Turning now to **Figure 1**, illustrated is a dried body **100** in accordance  
with some forms of the disclosed, dried composition. In some forms the dried  
body **100** comprises a porous composite material **101** comprising an admixture of a  
30 particulate ECM mixed with fructose and/or another sugar. In some forms, the  
dried body **100** is substantially flat, having at least a planar surface **110**, and an  
edge surface **112**.



In accordance with certain inventive variants, the dried body **100** of the present disclosure may be packaged in a sterilized container, as shown in **Figure 2**. In some forms the container **200** is a tray, or saucer. In certain forms, the container comprises polystyrene or any other suitable material compatible with sterilization. In some forms, the tray may be sealed within a sterilizable medical packaging pouch **300**. It will be understood for aspects herein that medical packaging other than that specifically shown in **Figure 2**, that also sterilely encloses the dried body **100** or any other inventive composition described herein, may be used.

In some forms, the disclosure also relates to a method of preparing a material for treating diseased and/or damaged tissue. In certain embodiments, the method comprises obtaining a dried body comprising extracellular matrix particulate and fructose. In some forms, the dried body is substantially as described above. In accordance with certain modes of practicing the disclosed method, the dried body is rehydrated, for example with an aqueous medium as described herein, to form a paste. The composition formed by the rehydration of the dried body may be of any suitable consistency for treated the targeted tissue.

In further embodiments, a putty composition as described herein is applied to a patient, such as a human or veterinary patient, for instance to treat diseased and/or damaged tissue. The composition may be applied by any suitable technique including, for example, injecting, spreading, infusing, filling, compressing, packing and/or engrafting. A diseased or damaged tissue to be treated may be any of a variety of such tissues, including soft and hard tissues such as skin, muscle, body wall tissue, connective tissue, ligaments, tendons, bone, and others. Illustratively, in some forms the putty can be forced into contact with tissue surfaces so as to conform to those tissues and promote repair, which repair may include the development of new tissue of the patient. In certain preferred treatments, the putty is applied to an open cutaneous wound of a patient, for example a cutaneous ulcer such as a diabetic ulcer, a burn, or other partial or full-thickness cutaneous wound.

To promote a further understanding of embodiments disclosed herein and their features and advantages, the following specific Examples are provided. It will be understood that these examples are illustrative, and not limiting, in nature.

## EXAMPLE 1

## Rehydration Time of Extracellular Matrix Particulate

Frozen particulate extracellular matrix tissue (comminuted small intestine submucosa) was provided as a starting material. The frozen particulate was divided into 10g portions and thawed. 50mg, 100mg, 200mg, or 500mg D-Fructose USP was added to each 10g portion of hydrated particulate ECM tissue (which equaled about 1 g dry weight of particulate ECM tissue). The combined materials were mixed in back and forth via two luer-locked syringes and dispensed into a 3.5" x 3.5" x 1" polystyrene weigh boat. The mixture was then lyophilized in the weigh boat to create a flat, dried, porous body.

The dried bodies were rehydrated using 6mL of 4% BSA in 1 x phosphate buffered saline. A metal spatula was used as needed to manipulate the sample and submerge in fluid. A timer was used to measure the time elapsed between addition of the fluid to when the sample was fully rehydrated as evidenced by the capacity to form a cohesive, shape-retaining ball. The results of the rehydration assay are reported in **Figure 3**. Illustratively, the samples containing 500mg of fructose exhibited an average rehydration time of 1:46, control samples without fructose exhibited an average rehydration time of 3:05.

20

## EXAMPLE 2

## Serum Uptake of Extracellular Matrix Particulate

Dried bodies prepared as in Example 1 were first rehydrated using 6mL of 4% BSA in 1xPBS as described in Example 1. To the rehydrated bodies was added additional fluid in 1mL increments until the sample could no longer retain a cohesive shape. The total amount of fluid each sample could uptake before losing its cohesive shape was recorded. The results of the serum uptake assay are reported in **Figure 4**. Illustratively, the samples containing 200mg of fructose were able to remain cohesive while absorbing an average of 9.6mL of fluid, control samples without fructose absorbed an average of 9.4mL of fluid.

30

The use of the terms "a" and "an" and "the" and similar referents in the context of describing the invention especially in the context of the following claims) are to be construed to cover both the singular and the plural, unless

otherwise indicated herein or clearly contradicted by context. Recitation of ranges of values herein are merely intended to serve as a shorthand method of referring individually to each separate value falling within the range, unless otherwise indicated herein, and each separate value is incorporated into the specification as if it were individually recited herein. All methods described herein can be performed in any suitable order unless otherwise indicated herein or otherwise clearly contradicted by context. The use of any and all examples, or exemplary language (e.g., “such as”) provided herein, is intended merely to better illuminate the invention and does not pose a limitation on the scope of the invention unless otherwise claimed. No language in the specification should be construed as indicating any non-claimed element as essential to the practice of the invention.

Further, any theory, mechanism of operation, proof, or finding stated herein is meant to further enhance understanding of the present invention, and is not intended to limit the present invention in any way to such theory, mechanism of operation, proof, or finding. While the invention has been illustrated and described in detail in the drawings and foregoing description, the same is to be considered as illustrative and not restrictive in character, it being understood that only selected embodiments have been shown and described and that all equivalents, changes, and modifications that come within the spirit of the inventions as defined herein or by the following claims are desired to be protected.

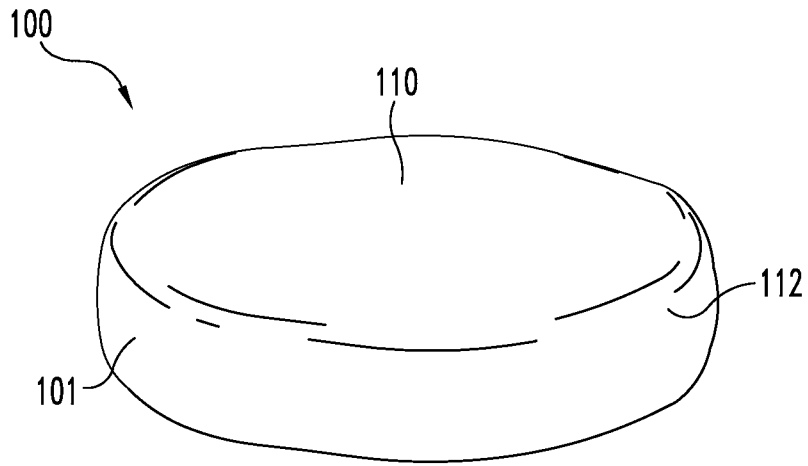
**CLAIMS**

1. A method of preparing a material, comprising:  
drying an admixture of materials comprising a particulate extracellular  
matrix tissue, sugar, and a liquid, so as to form a dried porous body, and wherein  
5 said dried porous body is wettable with an aqueous medium to form a shape-  
retainable formable putty.
2. The method of claim 1, wherein:  
said drying comprises lyophilizing.
3. The method of claim 1 or 2, further comprising locating the admixture in a  
10 mold, and wherein said drying is conducted with the admixture in the mold.
4. The method of any one of claims 1 to 3, wherein:  
said dried porous body has a mass of about 0.5g to about 5g.
5. The method of any one of claims 1 to 4, wherein:  
said particulate extracellular matrix tissue comprises submucosa.
- 15 6. The method of claim 5, wherein:  
said submucosa comprises intestinal, urinary bladder, stomach submucosa,  
or small intestinal submucosa (SIS).
7. The method of any one of claims 1 to 6, further comprising:  
sterilizing said dried porous body.
- 20 8. The method of any one of claims 1 to 7, wherein:  
said sugar comprises fructose.
9. The method of claim 8, wherein:  
said sugar is constituted of at least 50% of fructose.
10. The method of any one of claims 1 to 9, wherein the particulate ECM tissue  
25 and the sugar are present in a weight ratio of about 10:1 to about 1:1.
11. The method of claim 10, wherein the weight ratio of the particulate ECM  
tissue to the sugar is about 5:1 to about 1:1.
12. The method of claim 11, wherein the weight ratio of the particulate ECM  
tissue to the sugar is about 3:1 to about 1:1.

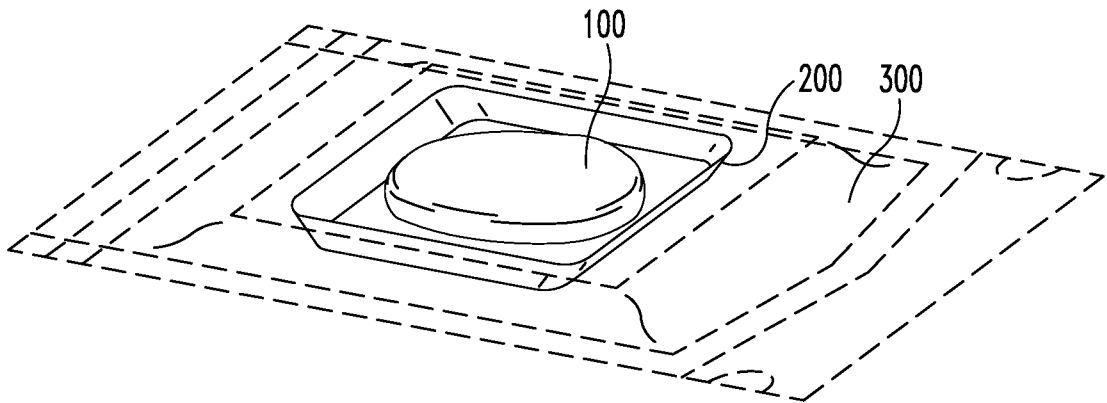
30

13. A method of preparing a material for treating a patient, comprising:  
rehydrating a dried body comprising an admixture of a particulate  
extracellular matrix tissue and sugar by combining an aqueous medium with the  
dried body to form a shape-retaining but formable putty.
- 5 14. The method of claim 13, wherein:  
said aqueous medium is or comprises blood or a blood fraction.
15. The method of claim 14, wherein:  
said blood or blood fraction is autologous to a subject that is to be treated  
with the material.
- 10 16. The method of claim 14 or 15, wherein:  
said aqueous medium is or comprises blood serum.
17. The method of any one of claims 13 to 16, wherein:  
said aqueous medium has a volume of about 5ml to about 10ml.
18. The method of any one of claims 13 to 17, wherein said material is  
15 formulated for administration to the patient.
19. Use of the material prepared according to the method of any one of claims  
13 to 18 for treating a patient.
20. A medical composition, comprising:  
an admixture comprising a particulate extracellular matrix (ECM) tissue  
20 and sugar, wherein said admixture is in the form of a dried porous body wettable  
with an aqueous medium to form a shape-retaining but formable putty, or in the  
form of a shape-retaining but formable putty also comprising an aqueous medium.
21. The medical composition of claim 20, wherein said admixture is in the  
form of the dried, porous body.
- 25 22. The medical composition of claim 21, wherein:  
said dried, porous body is lyophilized material.
23. The medical composition of claim 21 or 22, wherein:  
said dried, porous body has been sterilized.
24. The medical composition of any one of claims 20 to 23, wherein:  
30 the particulate ECM tissue and the sugar are present at a weight ratio of  
about 10:1 to about 1:1.

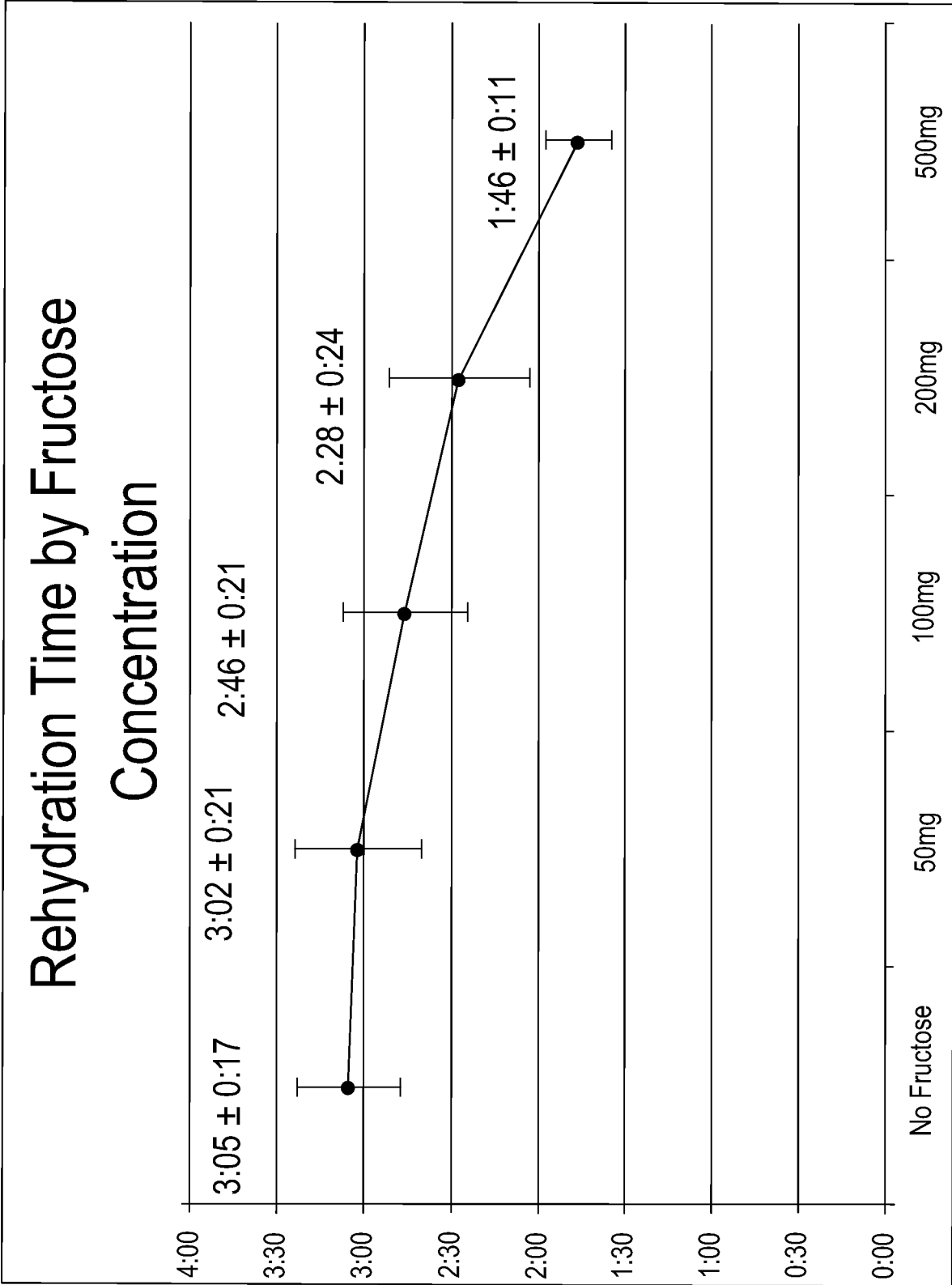
25. The medical composition of claim 24, wherein the weight ratio of the particulate ECM tissue to the sugar is about 5:1 to about 1:1.
26. The medical composition of claim 25, wherein the weight ratio of the particulate ECM tissue to the sugar is about 3:1 to about 1:1.
- 5 27. The medical composition of any one of claims 20 to 26, wherein:  
said composition is in the form of the shape-retaining but formable putty,  
and wherein the putty is constituted with about 70% to about 90% liquid.
28. The medical composition of any one of claims 20 to 26, wherein:  
said admixture is present in the dried, porous body, and wherein the dried  
10 porous body has a mass of about 0.5g to about 5g.
29. The medical composition of any one of claims 20 to 28, wherein:  
said particulate extracellular matrix tissue comprises submucosa.
30. The medical composition of claim 29, wherein:  
said submucosa comprises intestinal, urinary bladder, stomach submucosa,  
15 or small intestinal submucosa (SIS).
31. The medical composition of any one of claims 20 to 30, wherein:  
said sugar comprises fructose.
32. The medical composition of any one of claims 20 to 31, wherein:  
said particulate extracellular matrix tissue comprises at least one native  
20 growth factor retained from a source tissue for the extracellular matrix tissue.
33. The medical composition according to any one of claims 20 to 32, for  
treatment of a cutaneous wound.
34. The medical composition according to claim 33, for treatment of a  
cutaneous ulcer.



**Fig. 1**

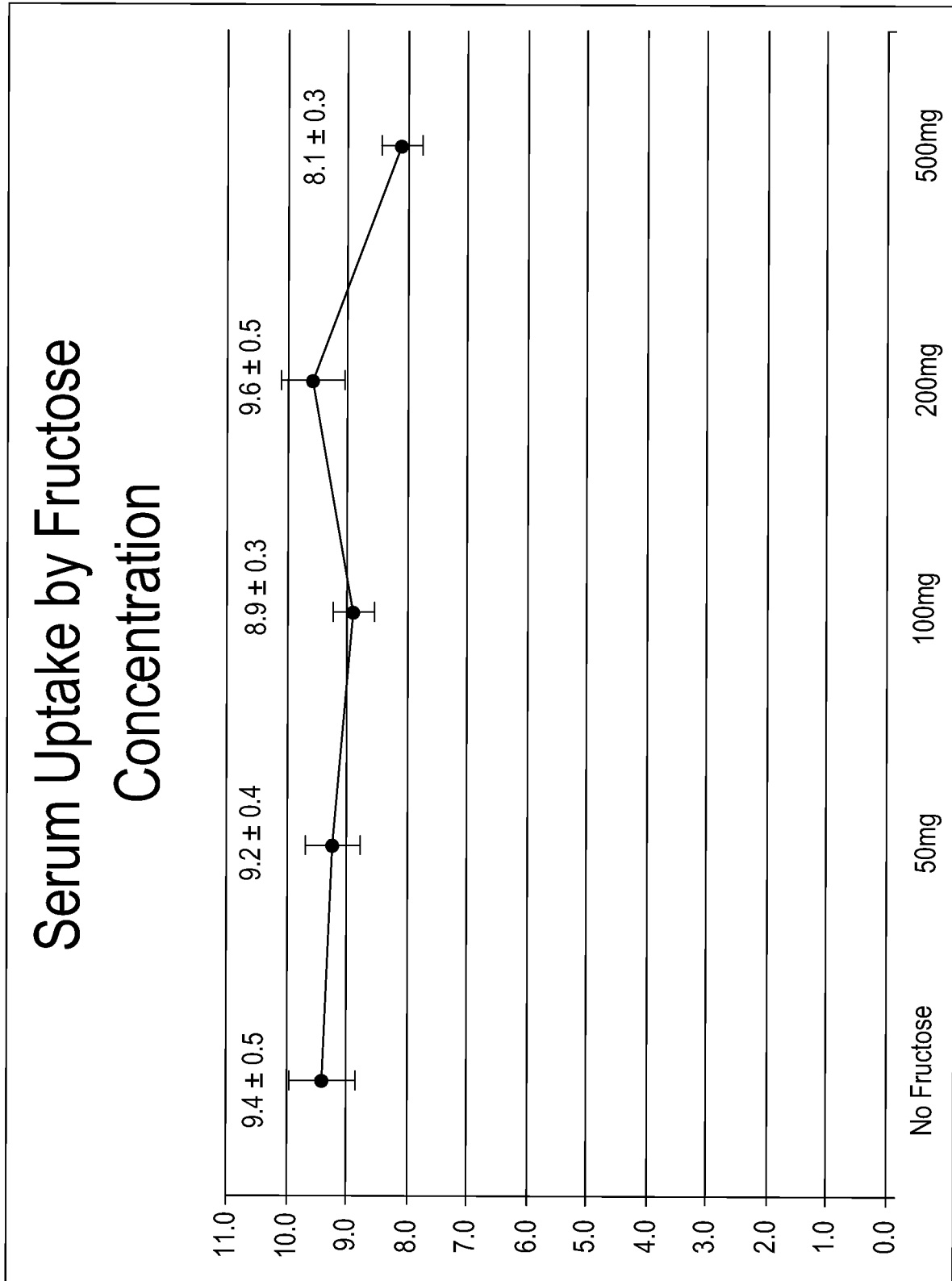


**Fig. 2**



**Fig. 3**





**Fig. 4**