



(19) **United States**

(12) **Patent Application Publication**
Candelore

(10) **Pub. No.: US 2009/0210346 A1**

(43) **Pub. Date: Aug. 20, 2009**

(54) **MULTIPLE DRM MANAGEMENT**

(52) **U.S. Cl. 705/57; 705/59; 705/51**

(76) **Inventor: Brant L. Candelore, Escondido, CA (US)**

(57) **ABSTRACT**

Correspondence Address:
MILLER PATENT SERVICES
2500 DOCKERY LANE
RALEIGH, NC 27606 (US)

A method for enabling a single assembly of content to be played on a plurality of player devices, each having at least one available DRM algorithm, wherein the DRM algorithms for the player devices need not necessarily be the same involves registering a plurality of player devices associated with a client with a database registry residing in a programmed processor, wherein each of the plurality of player devices is enabled to play content using at least one DRM algorithm when an appropriate license has been secured; registering the one or more associated DRM algorithms with each player device; upon receipt of a request for delivery of specified content to the client, searching the database registry for a list of compatible devices and compatible DRM algorithms for the content; obtaining a plurality of licenses to the content, at least one for each DRM algorithm for the player devices associated with the client; obtaining the content from a content provider; obtaining a shared key from a key generator for the one or more DRM algorithms; and encrypting the content under each of the DRM algorithms using the shared key to produce encrypted content. This abstract is not to be considered limiting, since other embodiments may deviate from the features described in this abstract.

(21) **Appl. No.: 12/386,632**

(22) **Filed: Apr. 21, 2009**

Related U.S. Application Data

(62) **Division of application No. 11/365,564, filed on Mar. 1, 2006, now Pat. No. 7,555,464.**

Publication Classification

(51) **Int. Cl. G06F 21/00 (2006.01)**

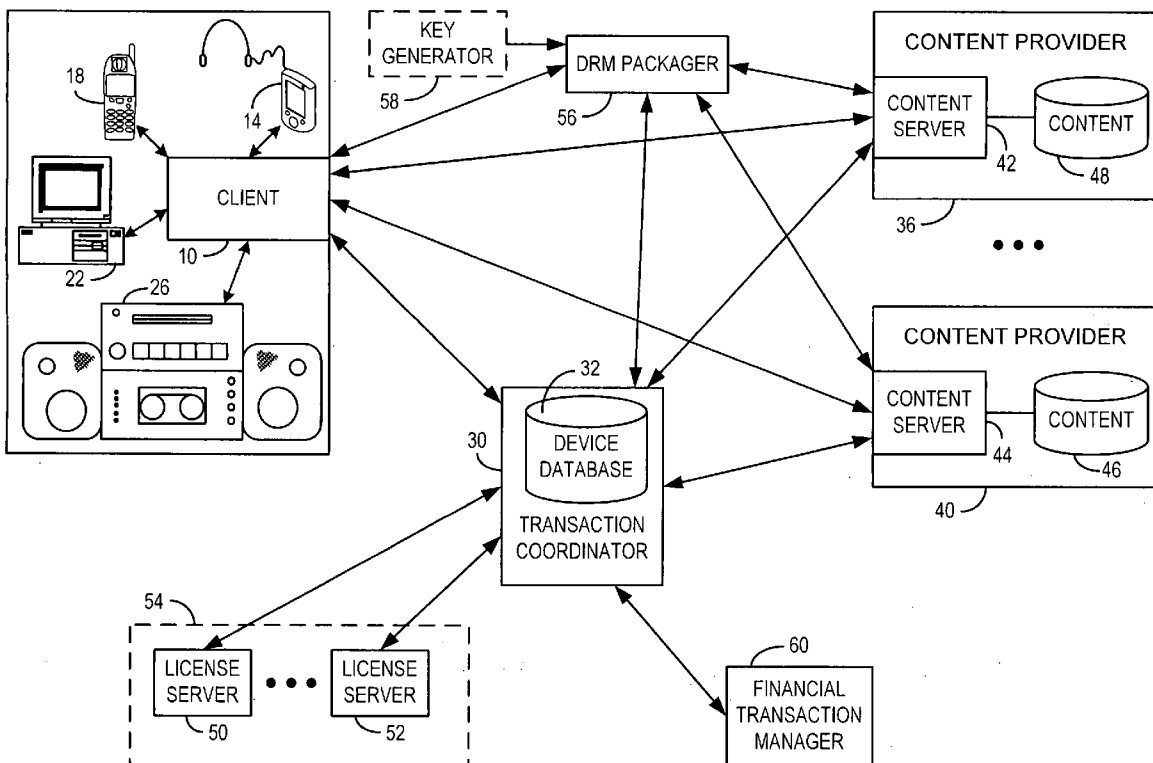

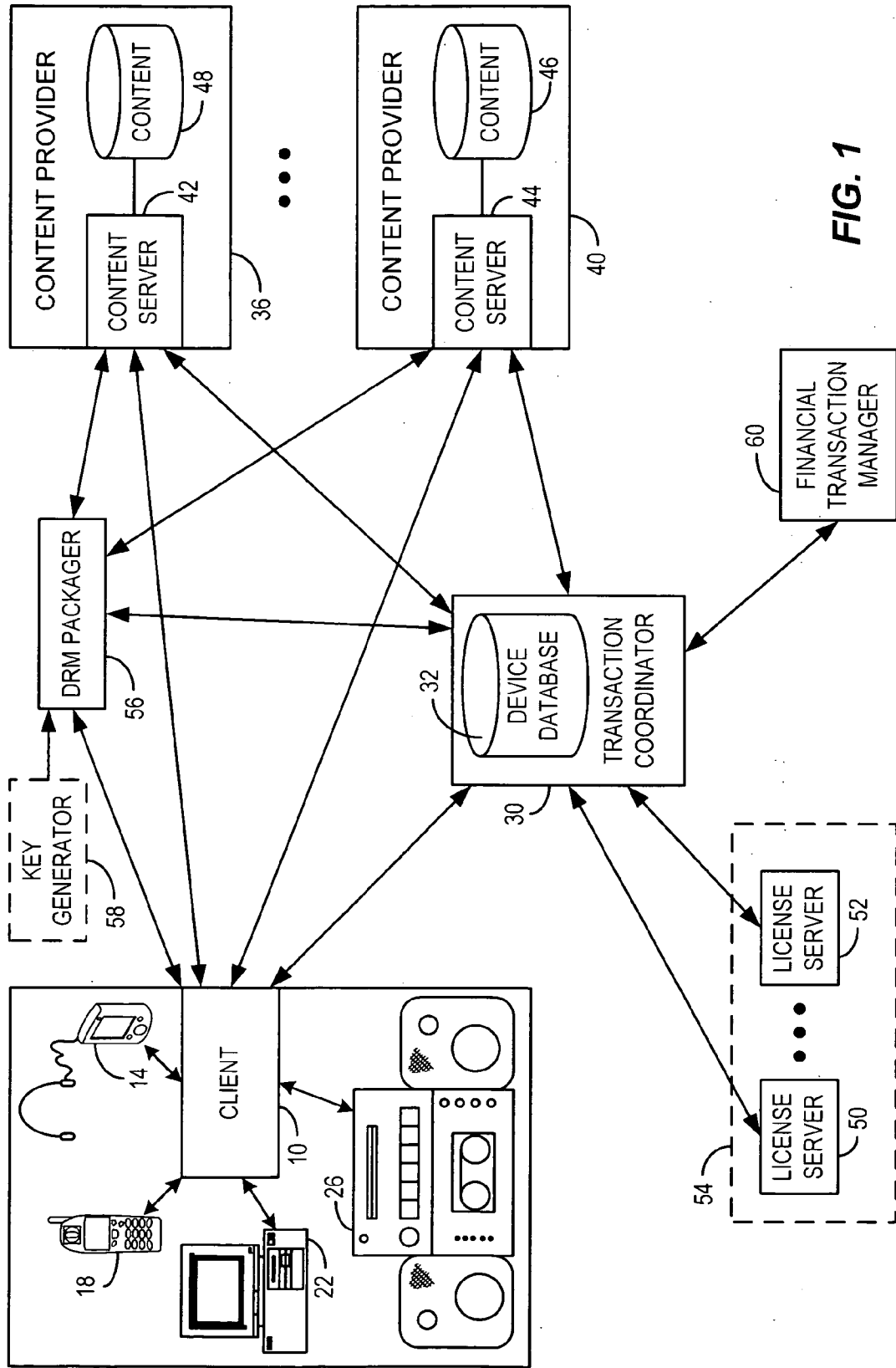

FIG. 1

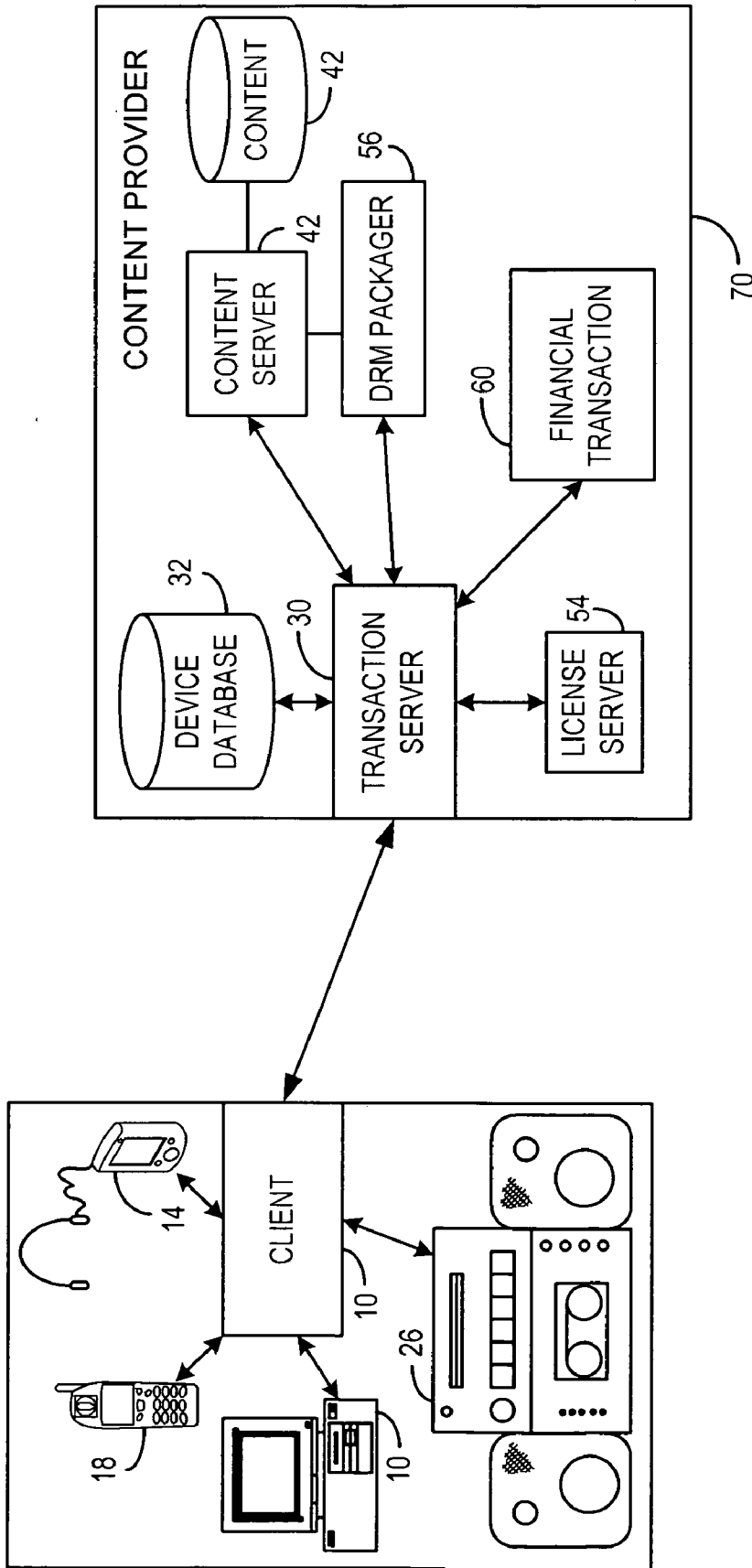
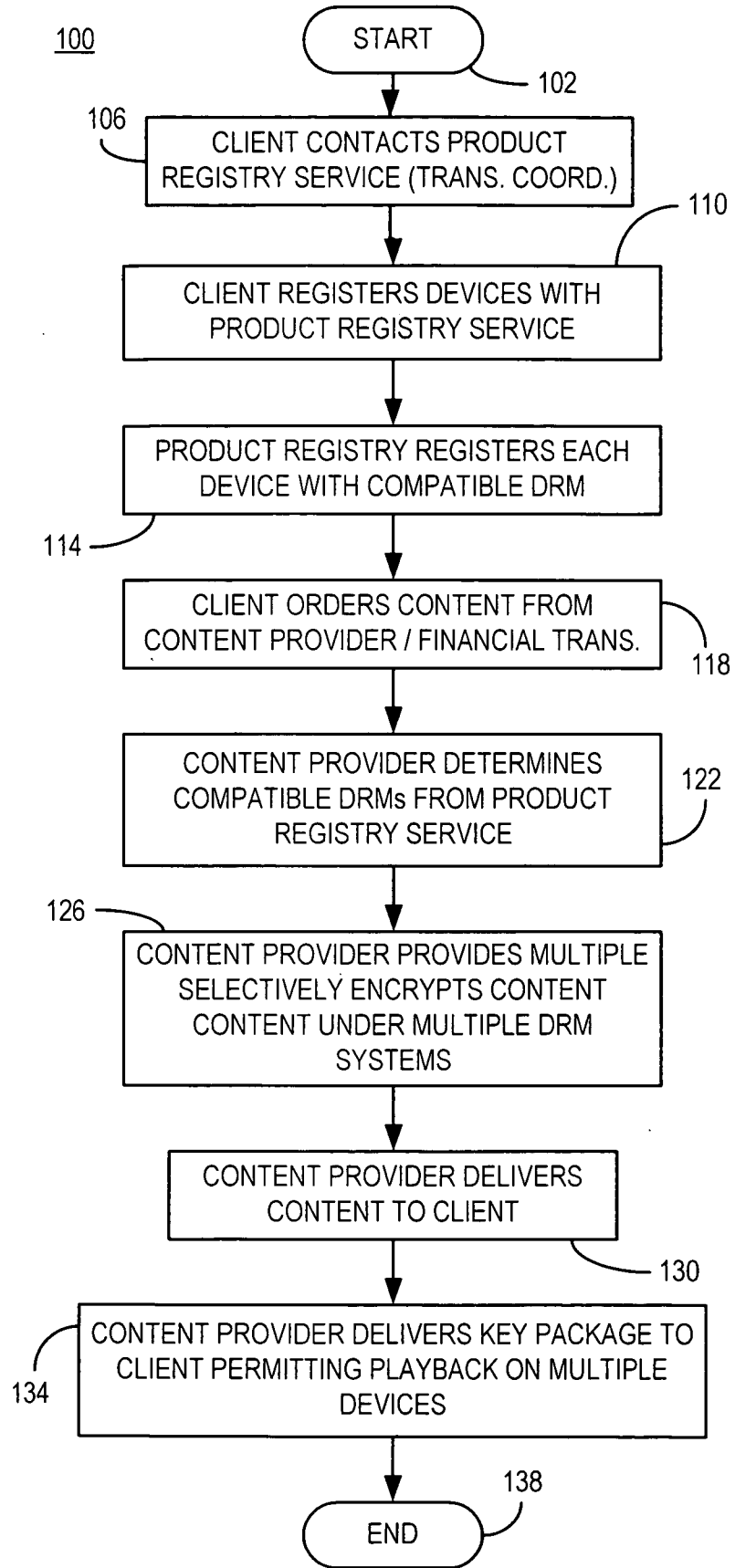

FIG. 2

FIG. 3



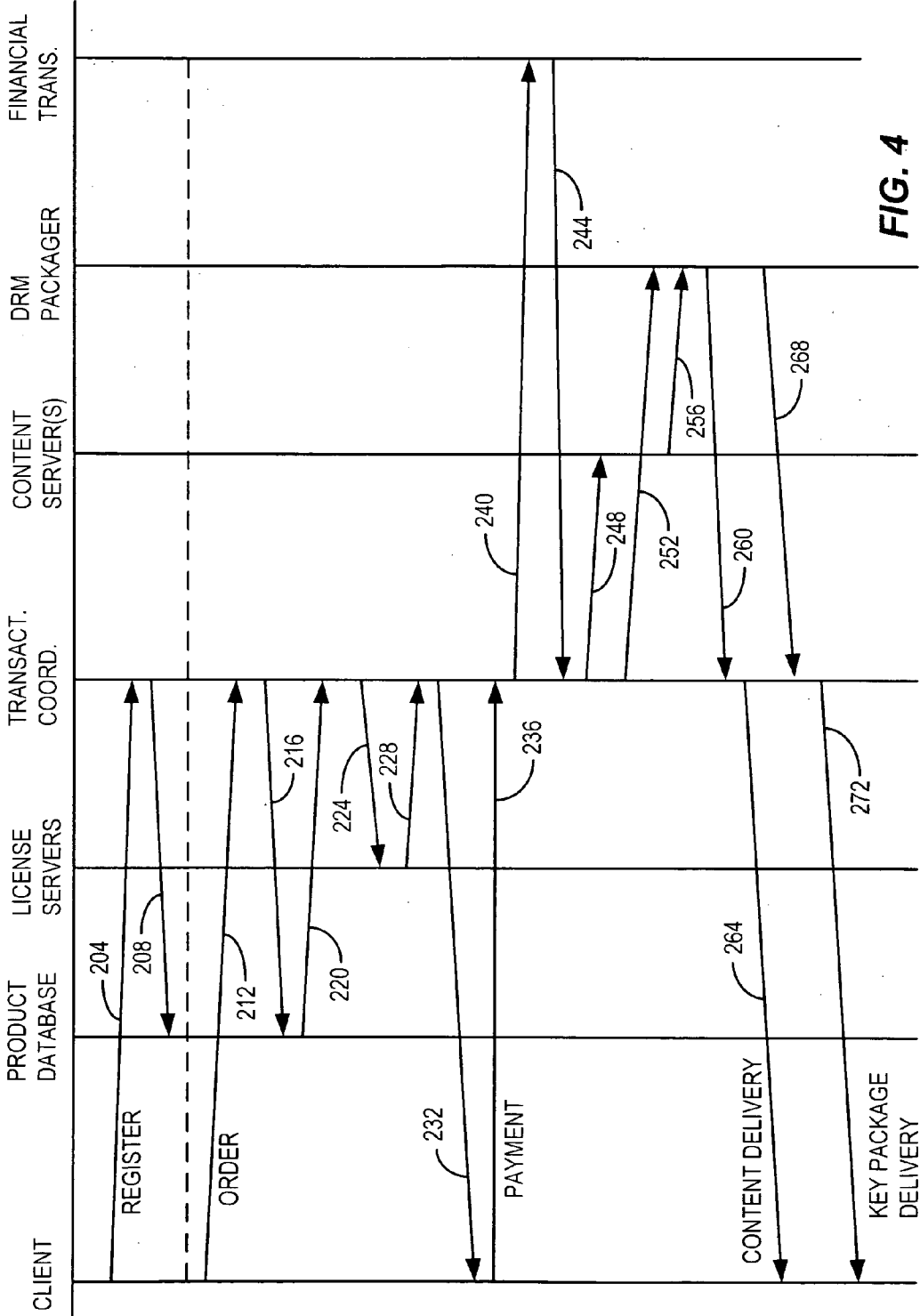

FIG. 4

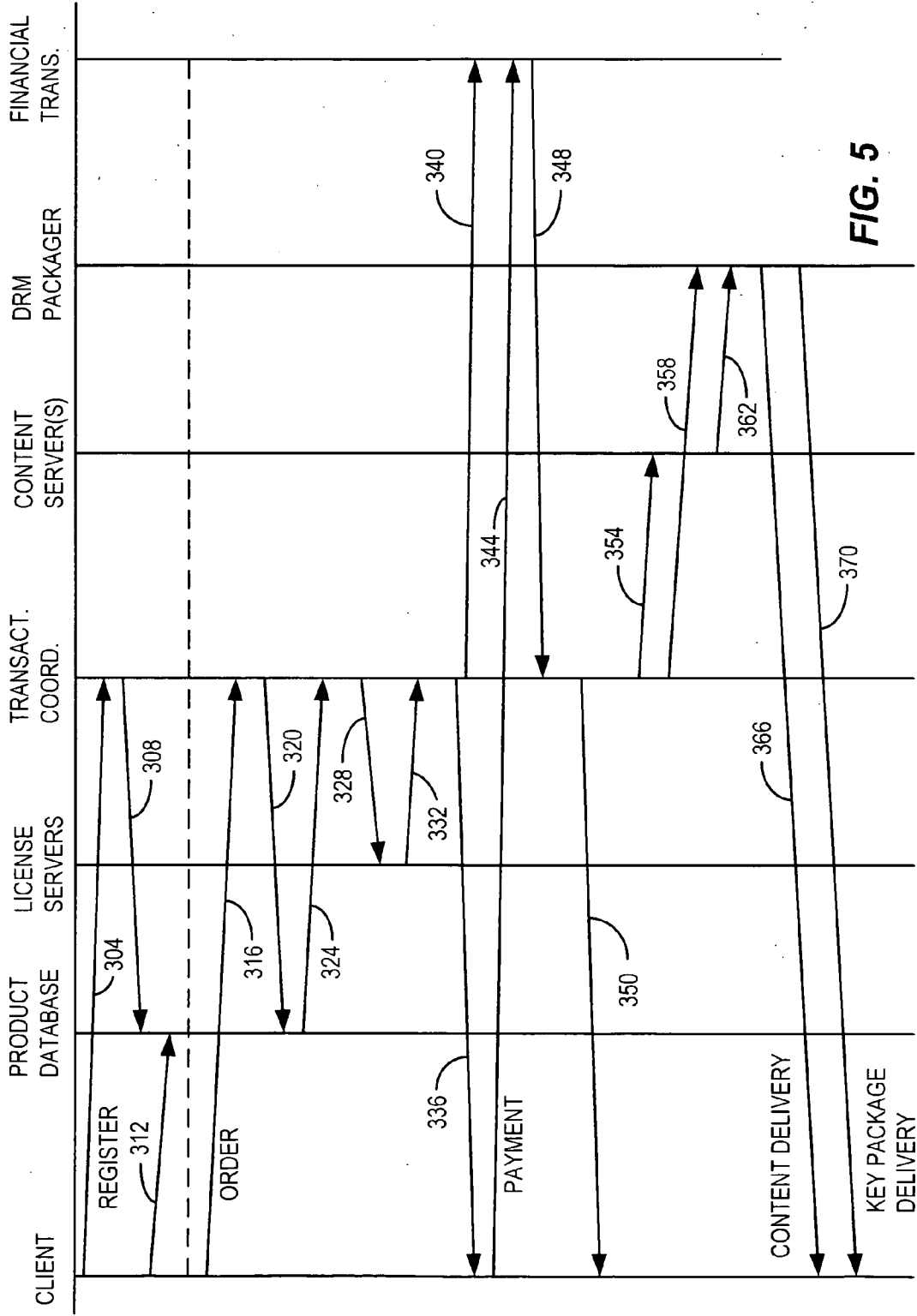

FIG. 5

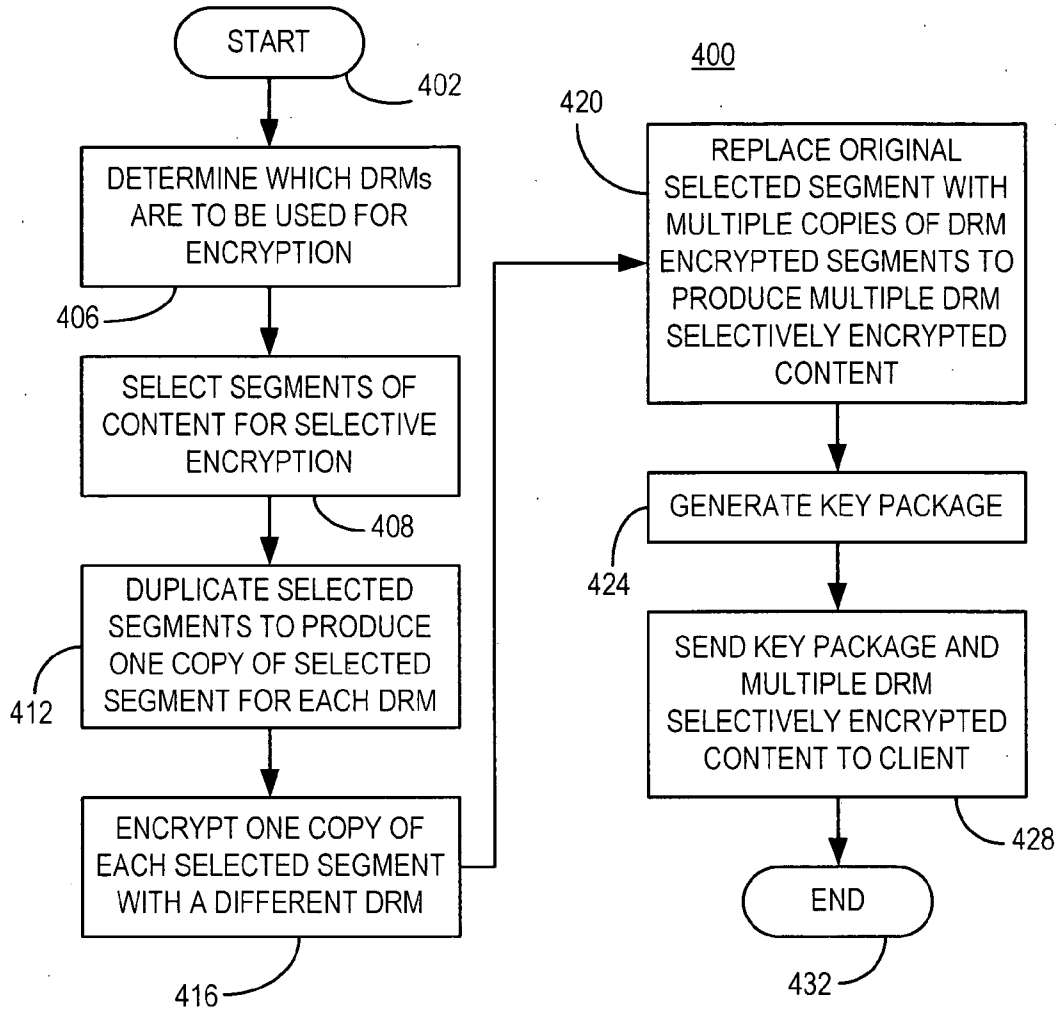

FIG. 6

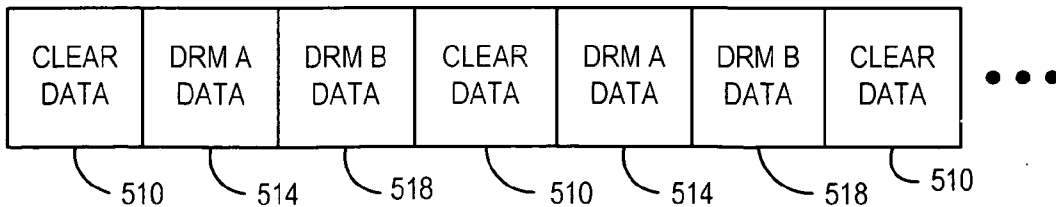

FIG. 7

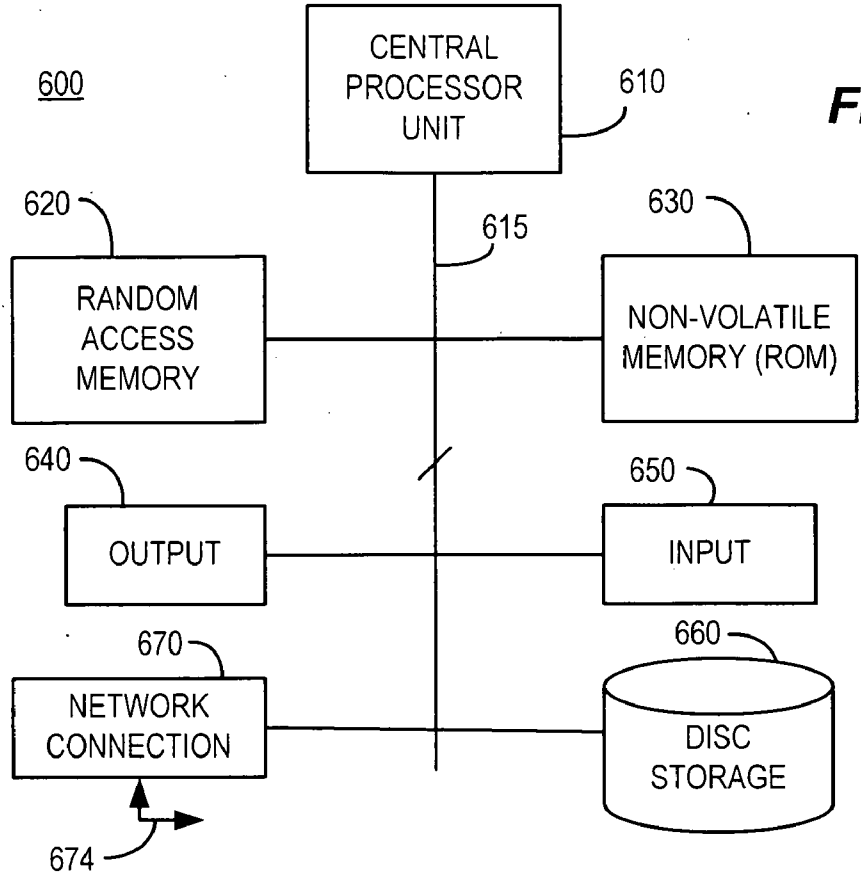

FIG. 8

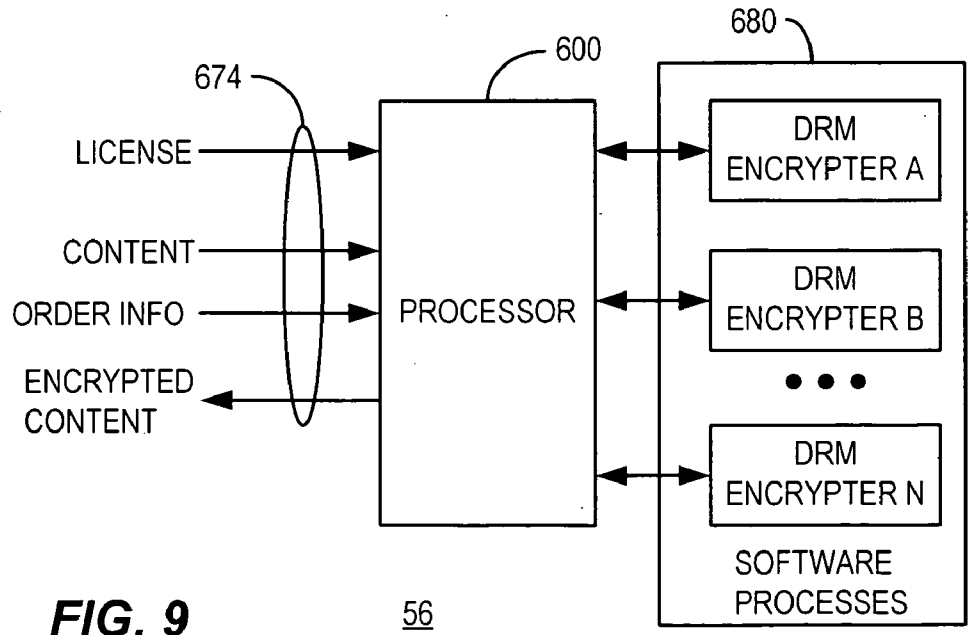

FIG. 9

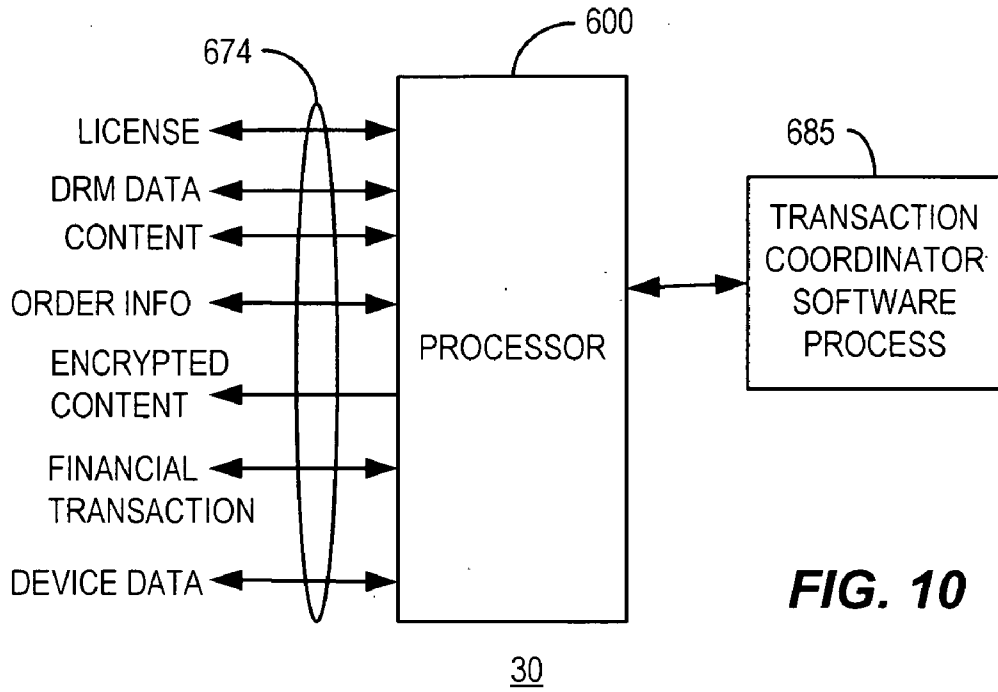

FIG. 10

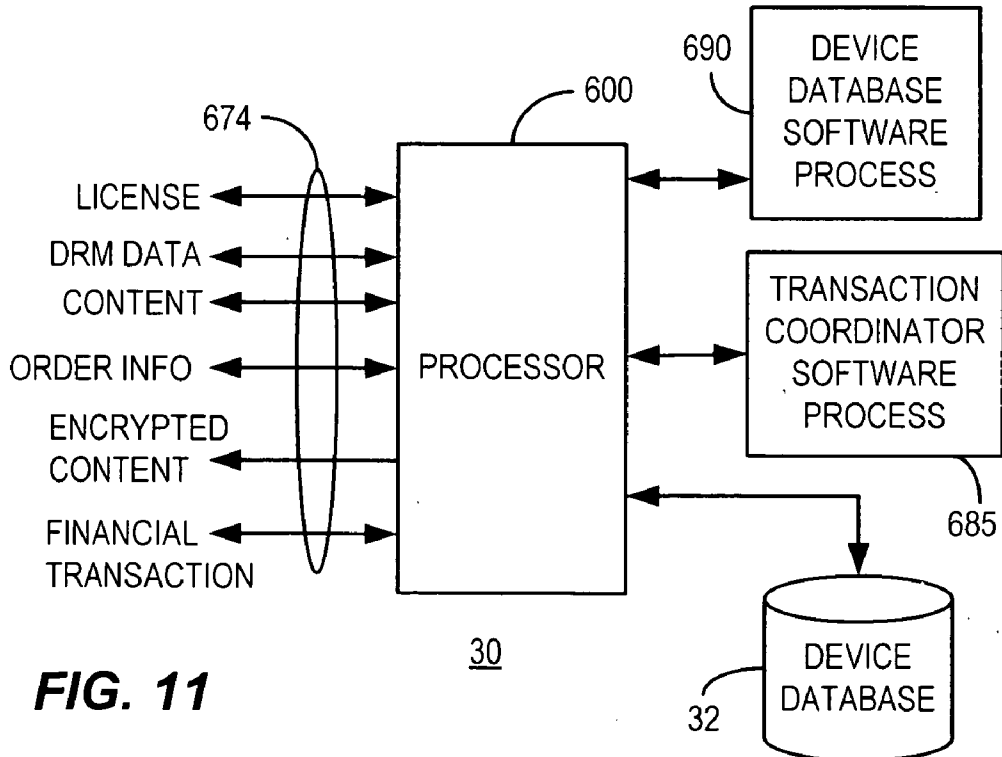

FIG. 11

MULTIPLE DRM MANAGEMENT

CROSS REFERENCE TO RELATED DOCUMENTS

[0001] This application is a divisional of allowed U.S. patent application Ser. No. 11/365,564 filed Mar. 1, 2006 and is related to published U.S. patent applications US2004/0049694, US2005/0192904 and US2005/0169473, to Brant L. Candelore which are hereby incorporated by reference.

COPYRIGHT NOTICE

[0002] A portion of the disclosure of this patent document contains material which is subject to copyright protection. The copyright owner has no objection to the facsimile reproduction of the patent document or the patent disclosure, as it appears in the Patent and Trademark Office patent file or records, but otherwise reserves all copyright rights whatsoever.

BACKGROUND

[0003] Currently, there are a number of competing digital rights management (DRM) algorithms that incorporate encryption for protection of copyrighted material. In general, such DRM algorithms are incompatible, and, therefore, content that is protected using a particular DRM algorithm cannot be played back on a device that does not incorporate an appropriate combination of hardware and software that is compatible with such DRM algorithm. In the case of a personal computer or similar device, DRM algorithms can often be downloaded or otherwise obtained and loaded into the computer's disc drive and memory in order to permit the personal computer to operate under any given DRM algorithm. However, some devices are designed to operate exclusively with a particular DRM algorithm. Those devices may be unable to upgrade or change DRM algorithms to match a particular item of content that a user wishes to play back. Additionally, some content may not be available encrypted using a particular type of DRM that is compatible with a playback device, and some DRM algorithms may be more desirable to some users or for a particular playback device for some reason than others.

[0004] A consumer of DRM protected content may wish to have the ability to play back that content on a number of different playback hardware devices. For example, video content or movies may be played back using a personal computer, a digital video recorder, a personal digital assistant, or even a cellular telephone. The flexibility needed to provide for a playback in any of an assortment of player devices is not currently well provided for in the marketplace.

BRIEF DESCRIPTION OF THE DRAWINGS

[0005] Certain illustrative embodiments illustrating organization and method of operation, together with objects and advantages may be best understood by reference detailed description that follows taken in conjunction with the accompanying drawings in which:

[0006] FIG. 1 is a first exemplary system block diagram of a multiple DRM selective encryption system arrangement consistent with certain embodiments of the present invention.

[0007] FIG. 2 is a second exemplary system block diagram of a multiple DRM selective encryption system arrangement consistent with certain embodiments of the present invention.

[0008] FIG. 3 is a flow chart depicting one embodiment of a method consistent with certain embodiments of the present invention.

[0009] FIG. 4 is an exemplary signal flow diagram depicting one embodiment consistent with the present invention.

[0010] FIG. 5 is another exemplary signal flow diagram depicting one embodiment consistent with the present invention.

[0011] FIG. 6 is a flow chart of a process consistent with certain embodiments of the present invention.

[0012] FIG. 7 is a diagram illustrating a multiple DRM encrypted data stream process consistent with certain embodiments of the present invention.

[0013] FIG. 8 is a block diagram of a computer system suitable for use in realizing certain of the blocks of FIG. 1 in a manner consistent with certain embodiments of the present invention.

[0014] FIG. 9 is a block diagram of a DRM packager consistent with certain embodiments of the present invention.

[0015] FIG. 10 is a block diagram of a transaction coordinator consistent with certain embodiments of the present invention.

[0016] FIG. 11 is a block diagram of a transaction coordinator with integral device database consistent with certain embodiments of the present invention.

DETAILED DESCRIPTION

[0017] While this invention is susceptible of embodiment in many different forms, there is shown in the drawings and will herein be described in detail specific embodiments, with the understanding that the present disclosure of such embodiments is to be considered as an example of the principles and not intended to limit the invention to the specific embodiments shown and described. In the description below, like reference numerals are used to describe the same, similar or corresponding parts in the several views of the drawings.

[0018] The terms "a" or "an", as used herein, are defined as one or more than one. The term "plurality", as used herein, is defined as two or more than two. The term "another", as used herein, is defined as at least a second or more. The terms "including" and/or "having", as used herein, are defined as comprising (i.e., open language). The term "coupled", as used herein, is defined as connected, although not necessarily directly, and not necessarily mechanically.

[0019] The term "program" or "computer program" or similar terms, as used herein, is defined as a sequence of instructions designed for execution on a computer system. A "program", or "computer program", may include a subroutine, a function, a procedure, an object method, an object implementation, in an executable application, an applet, a servlet, a source code, an object code, a shared library/dynamic load library and/or other sequence of instructions designed for execution on a computer system.

[0020] The term "program", as used herein, may also be used in a second context (the above definition being for the first context). In the second context, the term is used in the sense of a "television program", "radio program" or other similar content. In this context, the term is used to mean any coherent sequence of audio and/or video content which would be interpreted as and reported in a program guide, listing or catalog as a single program, without regard for whether the content is a movie, sporting event, segment of a multi-part series, news broadcast, etc. This term can also be used to refer to an installment of a "Podcast" or other elec-

tronic program material. The term “content” is used as generic to programs, videos, albums, computer programs, electronic games, songs, movies, electronic books and other types of material that is subject to copyright and/or may be protected by a digital rights management (DRM) arrangement.

[0021] Reference throughout this document to “one embodiment”, “certain embodiments”, “an embodiment” or similar terms means that a particular feature, structure, or characteristic described in connection with the embodiment is included in at least one embodiment of the present invention. Thus, the appearances of such phrases or in various places throughout this specification are not necessarily all referring to the same embodiment. Furthermore, the particular features, structures, or characteristics may be combined in any suitable manner in one or more embodiments without limitation.

[0022] The term “or” as used herein is to be interpreted as an inclusive or meaning any one or any combination. Therefore, “A, B or C” means “any of the following: A; B; C; A and B; A and C; B and C; A, B and C”. An exception to this definition will occur only when a combination of elements, functions, steps or acts are in some way inherently mutually exclusive.

[0023] The term digital rights management (DRM) is used herein as in the art to refer to various encryption and conditional access techniques used to establish security for content against piracy of the content while also governing the conditions of use of the content by authorized (e.g., paying) users. Various DRM algorithms and techniques are currently in use in the industry and are generally incompatible with each other. Several examples include, but are not limited to: Marlin DRM (Marlin Joint Development Association), Real Player DRM and Helix DRM (Real Networks, Inc.), Windows Media Player DRM (Microsoft Corp.), Secure Video Processor DRM (NDS), and OMA DRM (Open Mobile Alliance). The term DRM embraces these technologies as well as similar ones that exist or are devised in the future.

[0024] Referring now to FIG. 1, a particular individual or family (collectively referred to as client **10**) may have a variety of playback mechanisms at his disposal. For example, as depicted in FIG. 1, an exemplary client **10** has at his or her disposal a portable content player **14**, a wireless telephone **18**, a personal computer **22**, and a stereo system **26**. Other types of player devices include, but are not limited to, personal digital assistants (PDA), television receivers, digital video recorders (DVR or PVR), among others. For purposes of illustrating the current embodiments of the present invention, assume that each of client **10**'s available hardware devices are capable of operating on only a single DRM algorithm for playback of DRM protected content (this is not a necessary condition for realizing embodiments consistent with the present invention). If a client wishes to have the capability of playing back content (for example, a downloaded music file, video, radio program or television program), this would be virtually impossible under the current assumptions, that is, a single DRM encoded program that is playable on each of the client's player devices.

[0025] Therefore, if client **10** wishes to play the same content on all four devices, under the current assumptions, four separate sets of content generally must be obtained. This is not only costly, but involves four separate downloads and requires approximately four times as much storage space. In some circumstances, the problem can be ameliorated by

downloading new DRM algorithms for one or more of the devices so that the content is no longer exclusively usable on a single device (of course, this is contrary to the assumptions for this example). However, even under such circumstance, multiple copies of the content may be required if the user desires to play the content back on any of the available playback devices at his or her disposal.

[0026] In accordance with certain embodiments consistent with the present invention, a transaction coordinator **30** (or similar functional entity) used in conjunction with multiple DRM selective encryption as described in the above referenced patented publications provides a mechanism wherein a single unit or assembly of content (for example a song file) can be made usable on any number of the client's playback devices. In accordance with the current embodiment, client **10** makes contact with transaction coordinator **30** in order to carry out a registration process (e.g., wherein the transaction coordinator **30** operates as a part of a registration services) in which the client's playback devices **14**, **18**, **22** and **26** are registered with the transaction coordinator **30**. Upon registration of the device or devices, the transaction coordinator **30** stores identifying information in a device database **32** relating to client **10**, as well as the collection of playback devices available to client **10**. Then, either as a result of client **10** supplying information for the database **32** or by the database **32** independently determining the information, the particular DRM algorithm associated with each client device is tabulated and registered in device database **32** (which functions as a registry of the information). In this manner, client **10** can utilize transaction coordinator **30** in a process of acquisition of content such that the content is playable on each of the client's player devices.

[0027] In certain instances, for example for devices that are only enabled to utilize a single type of DRM, the transaction coordinator **30** can maintain a library of devices by model, manufacturer, etc. and can relate that model to the single type of DRM that is applicable to the device. In the case of a general purpose device such as a PDA, personal computer or other device that can be enabled by download of a particular DRM and operate under any one of a number of DRMs, transaction coordinator **30** can query the client **10** as to which types of DRM are available. Transaction coordinator may further request the preferred DRM if multiple DRMs are available.

[0028] Once a registration process is completed, client **10** may wish to place an order for a particular piece of content, such as a song or a movie. In so doing, transaction coordinator **30** either directly or indirectly coordinates the transaction in a manner that permits the content to be acquired in a form that is playable on all of the client's playback devices which are compatible with the type of content (i.e., video, audio, games, software, electronic book, movies, etc.). In some instances, content may only be playable on a single device (e.g., a proprietary game player), but in others, the content may be playable on two or more devices. While the transaction coordinator **30** can facilitate download of content for a single device, the more interesting aspect of certain embodiments occurs when multiple devices having differing DRM capability are being serviced.

[0029] An order is placed either to a content provider such as **36** or **40**. At each of a plurality of content providers, a content server such as **42** or **44** is provided which can access content from content databases such as **46** and **48**. When content is ordered by client **10**, the transaction coordinator **30**

looks up client **10** in its device database **32** to determine what DRM algorithms are needed to provide the client **10** with content that is playable on a selection of multiple devices. Once transaction coordinator **30** determines which DRM algorithms are needed, the transaction coordinator **30** can directly or indirectly obtain licenses from one or more license servers such as **50** and **52** (collectively **54**) and convey information associated with the acquired licenses to a DRM packager **56**. The DRM packager **56** obtains content from content server **42** or **44**, for example, and then formats the retrieved content. In a first exemplary embodiment consistent with the present invention the content is formatted as multiple DRM selectively encrypted content. With this embodiment, the DRM systems do not need to share content encryption keys or content encryption algorithms. Content encryption is independently handled by each DRM system. In a second embodiment consistent with the invention, the content is encrypted with a common content key, which is obtained from a Key Generator **58** which is shared between the DRM systems. In that alternative embodiment, the content encryption method must be common.

[0030] The DRM packager **56** packages the content for the client **10** by use of the license information obtained from the license servers **54** to determine how (i.e., using what encryption algorithm) to encrypt the content, and what digital rights to embed in the DRM encoding. The DRM packager then either, in the first exemplary embodiment, multiple DRM selectively encrypts the content for delivery to the client **10**, or in the second exemplary embodiment of the invention, encrypts the content (using a shared content key generated by key generator **58**) for delivery to the client **10**. This encrypted content is then transferred to the client **10** (either directly from the DRM packager, via one of the content providers or via transaction coordinator **30** or other intermediary). The client **10** is able to recover the appropriate content key from the licenses and then able to play the content on any appropriate playback device compatible with any of the DRM algorithms.

[0031] Multiple selective DRM encryption, used by one of the embodiments of the invention, is described in substantial detail in the above referenced patent applications, taken together with their parent or referenced patent applications. The process as it relates to the present process will be described in greater detail later.

[0032] In order for the playback devices to be able to play back the encrypted content, DRM packager **56** also transmits to the client **10** a key package. Such key package incorporates the decryption keys needed to decrypt the DRM encrypted content, and may also include digital rights limitations on the use of the content. Even if the content keys are shared, the content keys are encrypted or encoded by each DRM system. Thus, with both embodiments of the invention, using selective multiple DRM encryption and key sharing approaches, if three DRMs are utilized with multiple DRM selective encryption, at least three encrypted or encoded keys are sent to the client for use in either decrypting the content or decrypting a key used to decrypt the content. For purposes of this document, both possibilities and combinations thereof are to be considered equivalent.

[0033] In addition to the above, it is noted that most such downloaded transactions for playable content are carried out using the Internet. Moreover, a financial transaction manager **60** is generally involved in the process. Transaction coordinator **30** can either coordinate the financial transaction with financial transaction manager **60** or act as an intermediary for

the financial transaction manager **60** by actually collecting funds from the client and forwarding the funds or an appropriate portion thereof to the financial transaction recipient for use of the content. Such financial transaction may be carried out as an integral part of the present process and may be intimately involved with obtaining licenses for the content under the various DRM algorithms.

[0034] In FIG. 1, many of the elements utilized to accomplish the transaction and delivery of content as described above are depicted as being carried out at separate entities (DRM packager, content provider, license server, etc.). However, this need not be the case. Any or all of the entities beyond the client can be merged into a single entity or multiple entities that can efficiently carry out the process described. For example, the transaction coordinator can also be integrated with a plurality of license servers, and the DRM packager **56** may form a part of the same entity or may be part of a content provider. Numerous other arrangements are possible. FIG. 1 takes one extreme or near extreme view of the arrangement of the various entities associated with this transaction. In FIG. 1, each entity is depicted as a separate entity for purposes of carrying out the transaction.

[0035] Referring now to FIG. 2, another extreme of the possibility for arrangement of the various entities is depicted. In this depiction, content provider **70** is configured to carry out all of the functions described by the individual entities as previously described. In this embodiment, the transaction server **30** carries on all direct communication with client **10**. The device database **32** and license server **54**, as well as the financial transaction entity, are all packaged together as a seamless unit for supplying the DRM encrypted content to the client **10**. Content provider **70** further warehouses and supplies the electronic content in database **48** and maintains device database **32** which tracks the client's hardware and software capabilities.

[0036] Referring now to FIG. 3, a process **100** starting at **102** is presented which generally describes an exemplary overall process utilized in conjunction with embodiments consistent with the present invention. It should be noted, however, that many variations in this process are possible, including the ordering of the steps in the process. At **106**, the client **10** contacts the product registry service or transaction manager **30** in order to register the hardware and DRM capabilities available to the client. At **110**, the client **10** registers the devices with the product registry service (e.g., a transaction coordinator) so that later orders can be facilitated. At **114**, the product registry registers each device of the client and associates it with a compatible DRM. The compatible DRM may be either obtained by virtue by a lookup table or database used by the transaction manager **30** or may be independently supplied by the client **10**. At this point, the registration process is complete for registering the client's hardware and software.

[0037] At **118**, the client may place an order for content from the content provider and carry out an associated financial transaction. The content provider then determines compatible DRM from the product registry service at **122**. The client, at this point or some other convenient point in the process, may be asked to select any or all of the available content player devices for the selected content. The content provider at **126** provides encrypted content for the multiple DRM systems determined from the product registry database at **126**. At **130**, the content provider delivers content to the

client 10. At 134, the content provider delivers a key package to the client that permits playback on multiple devices. The process then ends at 138.

[0038] As previously noted, there are many configurations of transaction manager 30, content provider, and DRM packaging, etc. that are possible within the bounds of embodiments consistent with the present invention. Therefore, references in FIG. 3 to a particular entity are intended to be illustrative only and not limiting. For example, block 126 indicates that the content provider provides the multiple DRM selective encryption in the first embodiment of the invention. However, a separate DRM packager 56 may be utilized to do the multiple DRM selective encryption. Similarly, delivery of keys, as in block 134, may be carried out directly from the content provider, through a transaction coordinator, or through a DRM packager. No limitations on the source or arrangement of the services described should be implied from the particular illustrative embodiments set forth herein.

[0039] To further illustrate the diversity of arrangements that can be utilized to provide the services described herein, FIG. 4 provides a signal flow diagram that illustrates the registration and product delivery processes. In this embodiment, at 204, the client 10 sends registration information to a transaction coordinator 30. Transaction coordinator 30 then registers the data submitted by the client in a product database 32 at 208 to complete the registration process. Upon entry into the product database, the database is provided with hardware and software available to the client, as well as applicable DRM algorithms associated with each playback device.

[0040] When an order is to be placed, the client 10 again contacts the transaction coordinator 30 at 212 to place the order. At 216, the transaction coordinator 30 refers to the product database 32 to determine which DRM algorithms are applicable to the current order. At 220, the transaction coordinator 30 receives the DRM information requested. At 224, the transaction coordinator 30 coordinates with license servers 54 (or other licensing entities) to request the DRM information and licenses necessary to complete the order. Such information is then communicated back to the transaction coordinator at 228. It is envisioned that the licensing charges for a particular item of content may vary depending on how many and which licenses are necessary. Therefore, at 232, the transaction coordinator 30 may convey a price for the licenses to the client 10. (At this point, for example, the client may wish to specify which devices the content should be encoded for playback, or which DRMs should be used.) The client may then, at 236, provide payment to the transaction coordinator 30. The transaction coordinator 30 may then forward all or a portion of the payment to the entity or entities that are to be compensated in the financial transaction at 240.

[0041] Upon confirmation of receipt of the payment at 244, the transaction coordinator requests content from the content server at 248. The transaction coordinator 30 further requests DRM packaging from the DRM packager 56 at 252, and the content server delivers the content to the DRM packager 56 at 256. At 260, the DRM packager 56 delivers the content to the transaction coordinator who at 264 forwards the content to the client 10. At this point, the client 10 possesses the content, but is still unable to utilize it until the DRM packager 56 sends the key package to transaction coordinator 30 at 268, and the transaction coordinator 30 delivers the key package to the client at 272. At this point, in the first embodiment, the assembled content includes unencrypted content, as well as

content that is multiple DRM encrypted under multiple DRM algorithms for each of a plurality of segments of selected portions of the content. In the second embodiment, the content may be fully encrypted (using a shared content key). Thus, a single unified file or other unit of content can be utilized at the client 10 on any of a plurality of devices having incompatible DRM algorithms as their capability.

[0042] By way of illustrating an alternative, FIG. 5 depicts an arrangement wherein the transaction coordinator 30 is utilized in a slightly different manner and many of the transactions carried on by the client 10 are carried out more directly with the other entities as depicted in FIG. 1. In this embodiment, again a registration process is utilized starting at 304 where the client 10 contacts a transaction coordinator 30 to arrange registration in a product database 32 of his or her various playback devices (hardware and software). The transaction coordinator 30 at 308 informs the product database 32 of the desire for registration by the client 10, and the client 10 at 312 directly interacts with an entity that maintains the product database 32. At this point, the registration process is complete.

[0043] In order to place an order, the client 10 again contacts the transaction coordinator 30 at 316 (or in another embodiment contacts product database directly), and the transaction coordinator 30 obtains the DRM information at 320 from the product database 32. The product database 32 replies at 324 with the appropriate DRM data. Transaction coordinator 30 then solicits appropriate licenses at 328 from license servers 54, and at 322 receives the license information necessary to complete the transaction. At 336, the transaction coordinator 30 informs the client 10 that the appropriate licenses have been obtained and makes arrangements for a financial transaction at 340. At 344, the client 10 interacts directly with the financial transaction manager 60 to make payment for the content which has been ordered. Upon completion of this financial transaction, the financial transaction manager 60 coordinates with the transaction coordinator 30 at 348 to advise the transaction coordinator 30 that payment has been received. This is confirmed at 352 with the transaction coordinator 30 informing the client 10 that the transaction is complete and download is about to begin. At 354, the transaction coordinator 30 notifies the content server that the financial transaction has been completed and forwards appropriate licensing information to the content server.

[0044] At 358, the transaction coordinator 30 similarly informs the DRM packager 56 of the completion of the transaction and provides the DRM packager with appropriate data for the final packaging of the content in multiple DRM selectively encrypted form. At 362, the content server delivers the content to the DRM packager 56, and the DRM packager 56 packages the content with the appropriate multiple DRM selective encryption at 366 and forwards the content to the client 10. At 370, the DRM packager forwards the key package to the client. At this point, the client has everything needed to decrypt and utilize the content. As previously noted, key package delivery can entail delivery of keys to content, or a keys or keys to a key to content (or some combination thereof) using any suitable mechanism.

[0045] Referring now to FIG. 6, by way of a brief explanation for the first embodiment of the invention, a selective encryption technique as utilized herein to protect content from unauthorized copying is explained starting at 400. At 406, the transaction coordinator 30 or equivalent entity determines which DRMs are to be used for the multiple DRM

selective encryption. At **408**, as a part of the encryption technique, certain packets or other data units of the content are selected according to a selection criterion. This selection criterion can be any of a number of a selection criteria, but suffice it to say that if the segments of content that are selected by the selection criterion are encrypted, then the content itself will be unusable or seriously handicapped in use by anyone attempting to use the content in an unauthorized manner.

[0046] Once the segments of content are selected for encryption, those segments of content are duplicated at **412** to produce one copy for each DRM algorithm that is to be incorporated in the final assembly of content. Thus, if three DRM algorithms are to be utilized, a total of three identical copies of the selected content are encrypted using one DRM algorithm for each copy. The duplicated selected content is then encrypted with each copy being encrypted using a different DRM at **416**. The content is then reassembled with the originally selected portions removed and replaced by multiple copies of DRM encrypted selected segments at **420**. In this manner, portions of the content are multiply encrypted under three, in this case, different DRM algorithms. Where a single segment of content resides in the original content, three differently encrypted segments of content are inserted. A key package is then generated at **424** and the key package and multiple DRM selectively encrypted content is sent to the client at **428**. The process then ends at **432**.

[0047] This process results in a content stream that resembles that of FIG. 7. In this example, two DRMs are utilized and the resulting stream includes segments of clear content **510** followed by content encrypted under a first DRM (DRM A) and then content encrypted under a second DRM (DRM B). Using this technique, most playback devices will simply ignore packets or other segments of content that it cannot properly decode, and decode those segments that can be decoded or decrypted under a particular DRM algorithm. Thus, any of the available playback devices of client **10** can be utilized for playback of content.

[0048] It is noted that a content player may be a programmable device such as a programmable personal computer that is capable of operation under any one of a plurality of programmed DRM algorithms. As such, a single content player that operates under multiple DRM algorithms can be considered to be the equivalent of multiple content players. Delivery of the content can equivalently be accomplished via download, streaming or delivery of packaged media.

[0049] Thus, in one embodiment, a method for enabling a single assembly of content to be played on a plurality of player devices, each having at least one available digital rights management (DRM) algorithm, wherein the DRM algorithms for the player devices need not necessarily be the same involves registering a plurality of player devices associated with a client with a database registry, wherein each of the plurality of player devices is enabled to play content using at least one (DRM) algorithm when an appropriate license has been secured; upon registering the plurality of player devices, registering the one or more associated DRM algorithms with each player device; upon receipt of a request for delivery of specified content to the client, searching the database registry for a list of compatible devices and compatible DRM algorithms for the content; obtaining a plurality of licenses to the content, at least one for each DRM algorithm for the player devices associated with the client; obtaining the content from a content provider; and encrypting the content under each of the DRM algorithms to produce multiple DRM selectively

encrypted content, wherein the multiple DRM selectively encrypted content comprises: segments of the specified content that are unencrypted, and selected segments of the content which are duplicated to produce one copy of the selected content for each of the DRM algorithms with each duplicate copy of the selected segments encrypted under a different one of the DRM algorithms, and wherein, the unencrypted segments of content are assembled together with each of the DRM encrypted duplicate selected segments to produce a single unified content assembly that can be played on any of the player devices.

[0050] In certain embodiments, the method further involves delivering the multiple DRM selective encrypted content to the client. In certain embodiments, the method further involves the delivering of the content by at least one of download, streaming or delivery of packaged media. In certain embodiments, the plurality of licenses is obtained from at least one licensing server. In certain embodiments, the content is multiple DRM selective encrypted at a DRM packager. In certain embodiments, the DRM packager delivers the multiple DRM selective encrypted content directly to the client. In certain embodiments, the DRM packager delivers the multiple DRM selective encrypted content to the client via a transaction manager. A computer readable storage medium can store instructions which, when executed on a programmed processor, carry out any of these processes.

[0051] Another method consistent with certain embodiments for enabling a single assembly of content to be played on a plurality of player devices, each having at least one available digital rights management (DRM) algorithm, wherein the DRM algorithms for the player devices need not necessarily be the same, involves registering a plurality of player devices associated with a client with a database registry, wherein each of the plurality of player devices is enabled to play content using at least one (DRM) algorithm when an appropriate license has been secured; upon registering the plurality of player devices, registering the one or more associated DRM algorithms with each player device; upon receipt of a request for delivery of specified content to the client, searching the database registry for a list of compatible devices and compatible DRM algorithms for the content; obtaining a plurality of licenses to the content from at least one license server, at least one for each DRM algorithm for the player devices associated with the client; obtaining the content from a content provider; and at a DRM packager, encrypting the content under each of the DRM algorithms to produce multiple DRM selectively encrypted content, wherein the multiple DRM selectively encrypted content comprises: segments of the specified content that are unencrypted, and selected segments of the content which are duplicated to produce one copy of the selected content for each of the DRM algorithms with each duplicate copy of the selected segments encrypted under a different one of the DRM algorithms, and wherein, the unencrypted segments of content are assembled together with each of the DRM encrypted duplicate selected segments to produce a single unified content assembly that can be played on any of the player devices; the DRM packager electronically delivering the multiple DRM selective encrypted content directly to the client by either download or streaming.

[0052] A system, consistent with certain embodiments, for enabling a single assembly of content to be played on a plurality of player devices, each having at least one available digital rights management (DRM) algorithm has a database

that registers a plurality of player devices associated with a client with a database registry, wherein each of the plurality of player devices is enabled to play content using at least one (DRM) algorithm when an appropriate license has been secured. The database further registers one or more associated DRM algorithms with each player device. A transaction coordinator, upon receipt of a request for delivery of specified content to the client, obtains from the database a list of compatible devices and compatible DRM algorithms for the ordered content. The transaction coordinator further obtains a plurality of licenses to the content, at least one for each DRM algorithm for the player devices associated with the client. A content provider that provides the content, and a DRM packager that encrypts the content under each of the DRM algorithms to produce multiple DRM selectively encrypted content, wherein the multiple DRM selectively encrypted content comprises: segments of the specified content that are unencrypted, and selected segments of the content which are duplicated to produce one copy of the selected content for each of the DRM algorithms with each duplicate copy of the selected segments encrypted under a different one of the DRM algorithms, and wherein, the unencrypted segments of content are assembled together with each of the DRM encrypted duplicate selected segments to produce a single unified content assembly that can be played on any of the player devices.

[0053] In certain embodiments, the system further has at least one licensing server that provides a plurality of licenses to the content to the transaction coordinator. In certain embodiments, the system further has means for delivering the multiple DRM selective encrypted content to the client. In certain embodiments, the delivering of the content is by at least one of download, streaming or delivery of packaged media. In certain embodiments, the DRM packager delivers the multiple DRM selective encrypted content directly to the client. In certain embodiments, the DRM packager delivers the multiple DRM selective encrypted content to the client via the transaction manager. In certain embodiments, the database operates under control of the transaction manager. In certain embodiments, any or all of the transaction manager, DRM packager and license server operate under control of the content provider. In certain embodiments, the DRM packager operates under control of the content provider.

[0054] In another embodiment, a system for enabling a single assembly of content to be played on a plurality of player devices, each having at least one available digital rights management (DRM) algorithm has a database that registers a plurality of player devices associated with a client with a database registry, wherein each of the plurality of player devices is enabled to play content using at least one (DRM) algorithm when an appropriate license has been secured. The database further registers one or more associated DRM algorithms with each player device. A transaction coordinator, upon receipt of a request for delivery of specified content to the client, obtains from the database a list of compatible devices and compatible DRM algorithms for the ordered content. The transaction coordinator further obtains a plurality of licenses to the content, at least one for each DRM algorithm for the player devices associated with the client. A content provider provides the content and a DRM packager encrypts the content under each of the DRM algorithms to produce multiple DRM selectively encrypted content, wherein the multiple DRM selectively encrypted content comprises: segments of the specified content that are un-

encrypted, and selected segments of the content which are duplicated to produce one copy of the selected content for each of the DRM algorithms with each duplicate copy of the selected segments encrypted under a different one of the DRM algorithms, and wherein, the unencrypted segments of content are assembled together with each of the DRM encrypted duplicate selected segments to produce a single unified content assembly that can be played on any of the player devices. At least one licensing server provides a plurality of licenses to the content to the transaction coordinator. The multiple DRM selective encrypted content is delivered to the client by at least one of download, streaming or delivery of packaged media.

[0055] Those skilled in the art will recognize, upon consideration of the above teachings, that certain of the above exemplary embodiments are based upon use of a programmed processor. However, the invention is not limited to such exemplary embodiments, since other embodiments could be implemented using hardware component equivalents such as special purpose hardware and/or dedicated processors. Similarly, general purpose computers, microprocessor based computers, micro-controllers, optical computers, analog computers, dedicated processors, application specific circuits and/or dedicated hard wired logic may be used to construct alternative equivalent embodiments.

[0056] The processes previously described in connection with any of the transaction coordinator **30**, device database **32**, DRM packager **56**, financial transaction manager **60** and license server **54** can be carried out on a programmed general purpose computer system, such as the exemplary computer system **600** depicted in FIG. **8**. Computer system **600** has a central processor unit (CPU) **610** with an associated bus **615** used to connect the central processor unit **610** to Random Access Memory **620** and/or Non-Volatile Memory **630** in a known manner. An output mechanism at **640** may be provided in order to display and/or print output for the computer user. Similarly, input devices such as keyboard and mouse **650** may be provided for the input of information by the computer user. Computer **600** also may have disc storage **660** for storing large amounts of information including, but not limited to, program files and data files. Computer system **600** may be coupled to a local area network (LAN) and/or wide area network (WAN) and/or the Internet using a network connection **670** such as an Ethernet adapter coupling computer system **600**, possibly through a fire wall. The exact arrangement of the components of FIG. **8** will depend upon the function carried out in the particular one of the devices implemented. Additionally, the network connection **670** and network interface may depend upon whether the associated components are situated locally or remotely, with data passing to and from the processor system **600** via line **674**.

[0057] By way of example, FIG. **9** depicts a functional block diagram of one embodiment of a DRM packager **56** implemented in a processor system **600**. In this embodiment, license information, order information and content are received at **674** and the finally encrypted content is transmitted out at **674**. Processor **600** operates using software encryption processes **680** to carry out the DRM encryption as required.

[0058] FIG. **10** similarly illustrates one configuration and operation of a transaction coordinator **30** implemented using a processor system such as **600**. In this embodiment, network interface **670** communicates via network medium **674** to receive license data from the license servers **54** and sends

requests thereto. This interface also receives DRM data from the license server or transaction manager and content from the content provider. Order information, and financial transaction confirmations may also be received along with device/DRM data from the device database 32 when requested. The encrypted content is delivered via this interface. This operation is carried out under control of processor 600 running transaction coordinator software 685.

[0059] FIG. 11 similarly illustrates one configuration and operation of a transaction coordinator 30 implemented using a processor system such as 600 which additionally functions as the device database. In this embodiment, functions as described in connection with FIG. 10 are similarly carried out except that device data correlating devices to DRM algorithms are stored locally in device database 32 and processor 600 also functions as the database manager by running device database software 690.

[0060] Other arrangements can also be used by those skilled in the art upon consideration of the present teachings. For example, license servers 54 and financial transaction manager 60 may be similarly configured using general purpose processing components and may be integrated with certain of the other components.

[0061] Thus, a transaction manager consistent with certain embodiments has means for storing information in a database that registers a plurality of player devices associated with a client in a database, wherein each of the plurality of player devices is enabled to play content using at least one (DRM) algorithm when an appropriate license has been secured. One or more associated DRM algorithms with each said player device is stored in the database. The database software determines one or more compatible DRM algorithm associated with the client's player device from the database, upon receipt of a request for delivery of content to the client.

[0062] In certain embodiments, the transaction manager further has a mechanism for obtaining a plurality of licenses to the content, at least one for each DRM algorithm for a plurality of player devices associated with the client. In certain embodiments, the transaction manager may further arrange delivery of the content requested for delivery by the user from a content provider. In certain embodiments, the transaction manager arranges encryption by a DRM packager that encrypts the content under each of the DRM algorithms to produce encrypted content. The encrypted content may be multiple DRM selected encryption. The database may operate under control of the transaction manager. Any or all of the transaction manager, DRM packager and license server may operate under control of the content provider.

[0063] Furthermore, a DRM registry consistent with certain embodiments receives information relating a plurality of player devices associated with a client and storing the information in a database. The DRM registry software determines which of one or more DRM algorithms can be used with each of the player devices and storing the information in the database. The DRM registry retrieves one or more DRM algorithms associated with one or more player devices upon receipt of an inquiry. In certain embodiments, the DRM registry further has a transaction coordinator that, upon receipt of a request for delivery of specified content to the client, issues a query to the database to obtain from the database a list of compatible devices and compatible DRM algorithms for the ordered content.

[0064] A DRM packager consistent with certain embodiments has a processor that receives licensing information

including a plurality of encryption keys for a corresponding plurality of DRM encryption algorithms. The DRM packager receives content from a content provider. An encrypter encrypts the content under each of the plurality of DRM algorithms to produce multiple DRM selectively encrypted content, wherein the multiple DRM selectively encrypted content as previously described. In certain embodiments, at least one licensing server provides the license information to the DRM packager. In certain embodiments the DRM packager further has means for delivering the multiple DRM selective encrypted content to a client by at least one of download, streaming or delivery of packaged media, and means for delivering a key package to the client. The DRM packager may deliver the multiple DRM selective encrypted content directly to a client, or, the DRM packager may deliver the multiple DRM selective encrypted content to the client via a transaction manager.

[0065] A method for enabling a single assembly of content to be played on a plurality of player devices, each having at least one available digital rights management (DRM) algorithm, consistent with certain embodiments, involves registering a plurality of player devices associated with a client with a database registry, wherein each of the plurality of player devices is enabled to play content using at least one (DRM) algorithm when an appropriate license has been secured; upon registering the plurality of player devices, registering the one or more associated DRM algorithms with each player device; upon receipt of a request for delivery of specified content to the client, searching the database registry for a list of compatible devices and compatible DRM algorithms for the content; obtaining a plurality of licenses to the content, at least one for each DRM algorithm for the player devices associated with the client; obtaining the content from a content provider; obtaining a shared key from a key generator for the one or more DRM algorithms; and encrypting the content under each of the DRM algorithms using the shared key to produce encrypted content.

[0066] In certain embodiments, the method also involves delivering the encrypted content to the client. In certain embodiments, the plurality of licenses is obtained from at least one licensing server. In certain embodiments, the encrypted content is delivered to the client via a transaction manager. A computer readable storage medium storing instructions which, when executed on a programmed processor, can carry out the above process.

[0067] In another embodiment consistent with the present invention, a system for enabling a single assembly of content to be played on a plurality of player devices, each having at least one available digital rights management (DRM) algorithm has a database that registers a plurality of player devices associated with a client with a database registry, wherein each of the plurality of player devices is enabled to play content using at least one (DRM) algorithm when an appropriate license has been secured. The database further registers one or more associated DRM algorithms with each player device. A transaction coordinator, upon receipt of a request for delivery of specified content to the client, obtains from the database a list of compatible devices and compatible DRM algorithms for the ordered content. The transaction coordinator further obtains a plurality of licenses to the content, at least one for each DRM algorithm for the player devices associated with the client. A content provider provides the content and a key generator generates a key shared among the DRM algorithms.

A DRM packager encrypts the content using the key shared among the DRM algorithms to produce encrypted content.

[0068] In certain embodiments, the system also has at least one licensing server that provides a plurality of licenses to the content to the transaction coordinator. In certain embodiments, the system also delivers the encrypted content to the client. In certain embodiments, the DRM packager-delivers the encrypted content directly to the client. In certain embodiments, the DRM packager delivers the encrypted content to the client via the transaction manager.

[0069] Software and/or firmware embodiments may be implemented using a programmed processor executing programming instructions that in certain instances are broadly described above in flow chart and signal flow diagram form that can be stored on any suitable electronic or computer readable storage medium (such as, for example, disc storage, Read Only Memory (ROM) devices, Random Access Memory (RAM) devices, network memory devices, optical storage elements, magnetic storage elements, magneto-optical storage elements, flash memory, core memory and/or other equivalent volatile and non-volatile storage technologies) and/or can be transmitted over any suitable electronic communication medium. However, those skilled in the art will appreciate, upon consideration of the present teaching, that the processes described above can be implemented in any number of variations and in many suitable programming languages without departing from embodiments of the present invention. For example, the order of certain operations carried out can often be varied, additional operations can be added or operations can be deleted without departing from certain embodiments of the invention. Error trapping can be added and/or enhanced and variations can be made in user interface and information presentation without departing from certain embodiments of the present invention. Such variations are contemplated and considered equivalent.

[0070] While certain illustrative embodiments have been described, it is evident that many alternatives, modifications, permutations and variations will become apparent to those skilled in the art in light of the foregoing description.

What is claimed is:

1. A method for enabling a single assembly of content to be played-on a plurality of player devices, each having at least one available digital rights management (DRM) algorithm, wherein the DRM algorithms for the player devices need not necessarily be the same, comprising:

registering a plurality of player devices associated with a client with a database registry residing in a programmed processor, wherein each of the plurality of player devices is enabled to play content using at least one (DRM) algorithm when an appropriate license has been secured;

upon registering the plurality of player devices, registering the one or more associated DRM algorithms with each player device;

upon receipt of a request for delivery of specified content to the client, searching the database registry for a list of compatible devices and compatible DRM algorithms for the content;

obtaining a plurality of licenses to the content, at least one for each DRM algorithm for the player devices associated with the client;

obtaining the content from a content provider; obtaining a shared key from a key generator for the one or more DRM algorithms; and encrypting the content under each of the DRM algorithms using the shared key to produce encrypted content.

2. The method according to claim 1, further comprising delivering the encrypted content to the client.

3. The method according to claim 1, wherein the plurality of licenses are obtained from at least one licensing server.

4. The method according to claim 1, wherein the encrypted content is delivered to the client via a transaction manager.

5. A computer readable storage medium storing instructions which, when executed on a programmed processor, carry out a process according to claim 1.

6. A system for enabling a single assembly of content to be played on a plurality of player devices, each having at least one available digital rights management (DRM) algorithm, wherein the DRM algorithms for the player devices need not necessarily be the same, comprising:

a programmed processor having a database that registers a plurality of player devices associated with a client with a database registry, wherein each of the plurality of player devices is enabled to play content using at least one (DRM) algorithm when an appropriate license has been secured;

the database further registering one or more associated DRM algorithms with each player device;

a transaction coordinator that, upon receipt of a request for delivery of specified content to the client, obtains from the database a list of compatible devices and compatible DRM algorithms for the ordered content;

the transaction coordinator further obtaining a plurality of licenses to the content, at least one for each DRM algorithm for the player devices associated with the client;

a content provider that provides the content;

a key generator that generates a key shared among the DRM algorithms; and

a DRM packager that encrypts the content using a key shared among the DRM algorithms to produce encrypted content.

7. The system according to claim 6, further comprising at least one licensing server that provides a plurality of licenses to the content to the transaction coordinator.

8. The system according to claim 6, further comprising means for delivering the encrypted content to the client.

9. The system according to claim 6, wherein the DRM packager delivers the encrypted content directly to the client.

10. The system according to claim 6, wherein the DRM packager delivers the encrypted content to the client via the transaction manager.

11. The system according to claim 6, wherein the database operates under control of the transaction manager.

12. The system according to claim 6, wherein the transaction manager, DRM packager and license server operate under control of the content provider.

13. The system according to claim 6, wherein the DRM packager operates under control of the content provider.

* * * * *