



US 20170020697A1

(19) **United States**

(12) **Patent Application Publication**
HOSSAINY et al.

(10) **Pub. No.: US 2017/0020697 A1**

(43) **Pub. Date: Jan. 26, 2017**

(54) **40-O-(2-HYDROXY)ETHYL-RAPAMYCIN
COATED STENT**

(22) Filed: **Sep. 30, 2016**

Related U.S. Application Data

(71) Applicant: **Advanced Cardiovascular Systems
Inc.**, Santa Clara, CA (US)

(63) Continuation of application No. 10/108,004, filed on
Mar. 27, 2002, now abandoned.

Publication Classification

(72) Inventors: **Syed F.A. HOSSAINY**, Fremont, CA
(US); **Gordon STEWART**, San
Francisco, CA (US); **Mark A.
WILLIAMS**, Redwood City, CA (US);
Jeff ROYAL, San Francisco, CA (US);
Paul M. CONSIGNY, San Jose, CA
(US); **Dorrie M. HAPP**, Madison, WI
(US); **Kurt SCHEINPFLUG**,
Sunnyvale, CA (US); **Ty HU**, Mountain
View, CA (US)

(51) **Int. Cl.**
A61F 2/844 (2006.01)
A61L 31/16 (2006.01)
(52) **U.S. Cl.**
CPC *A61F 2/844* (2013.01); *A61L 31/16*
(2013.01); *A61L 2300/606* (2013.01); *A61L*
2300/416 (2013.01); *A61F 2250/0067*
(2013.01)

(21) Appl. No.: **15/282,971**

(57) **ABSTRACT**

A method and coating for reducing the release rate of an
active agent from an implantable device, such as a stent, is
disclosed.

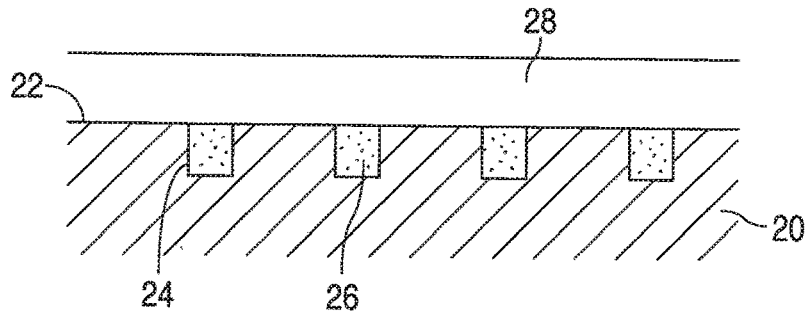

FIG. 1A

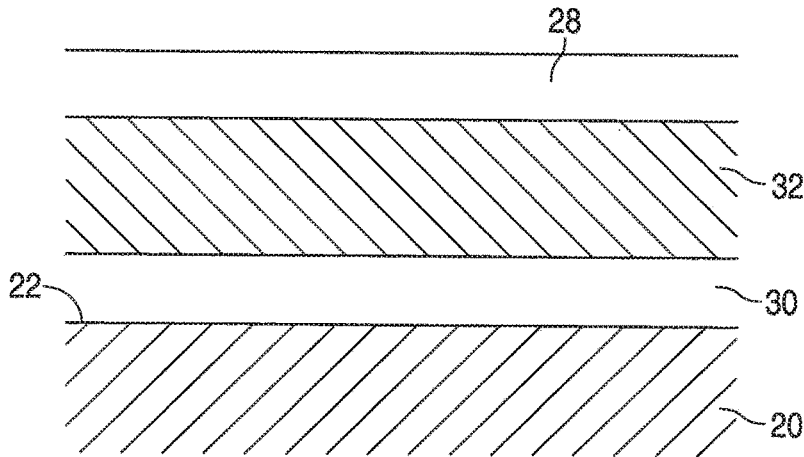

FIG. 1B

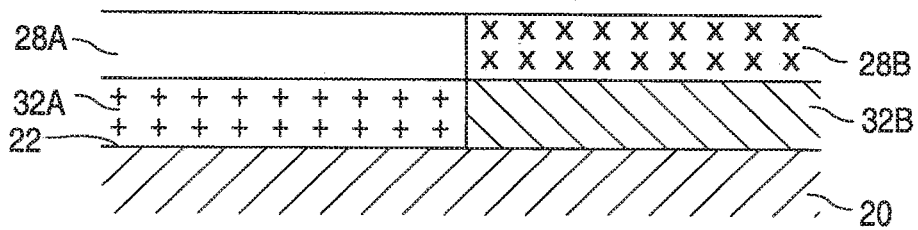

FIG. 1C

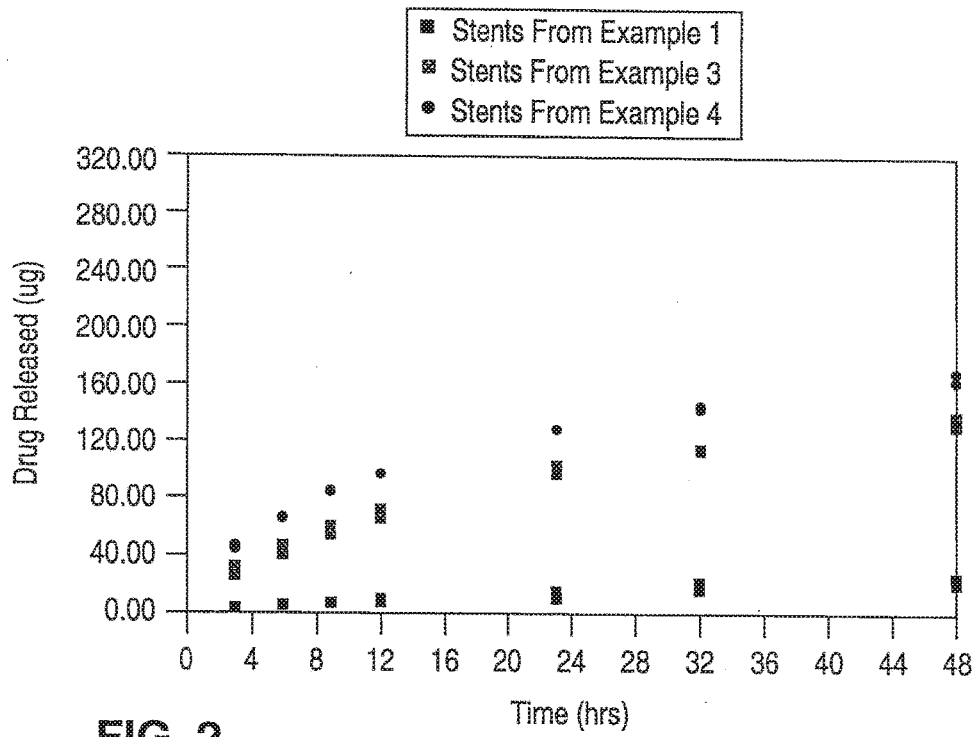

FIG. 2

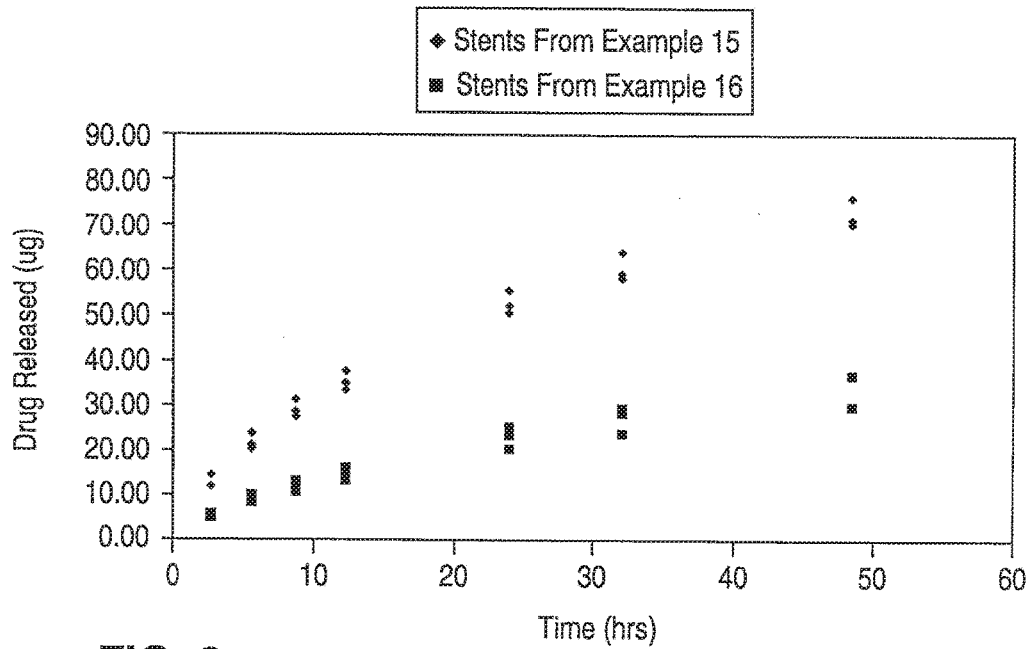

FIG. 3

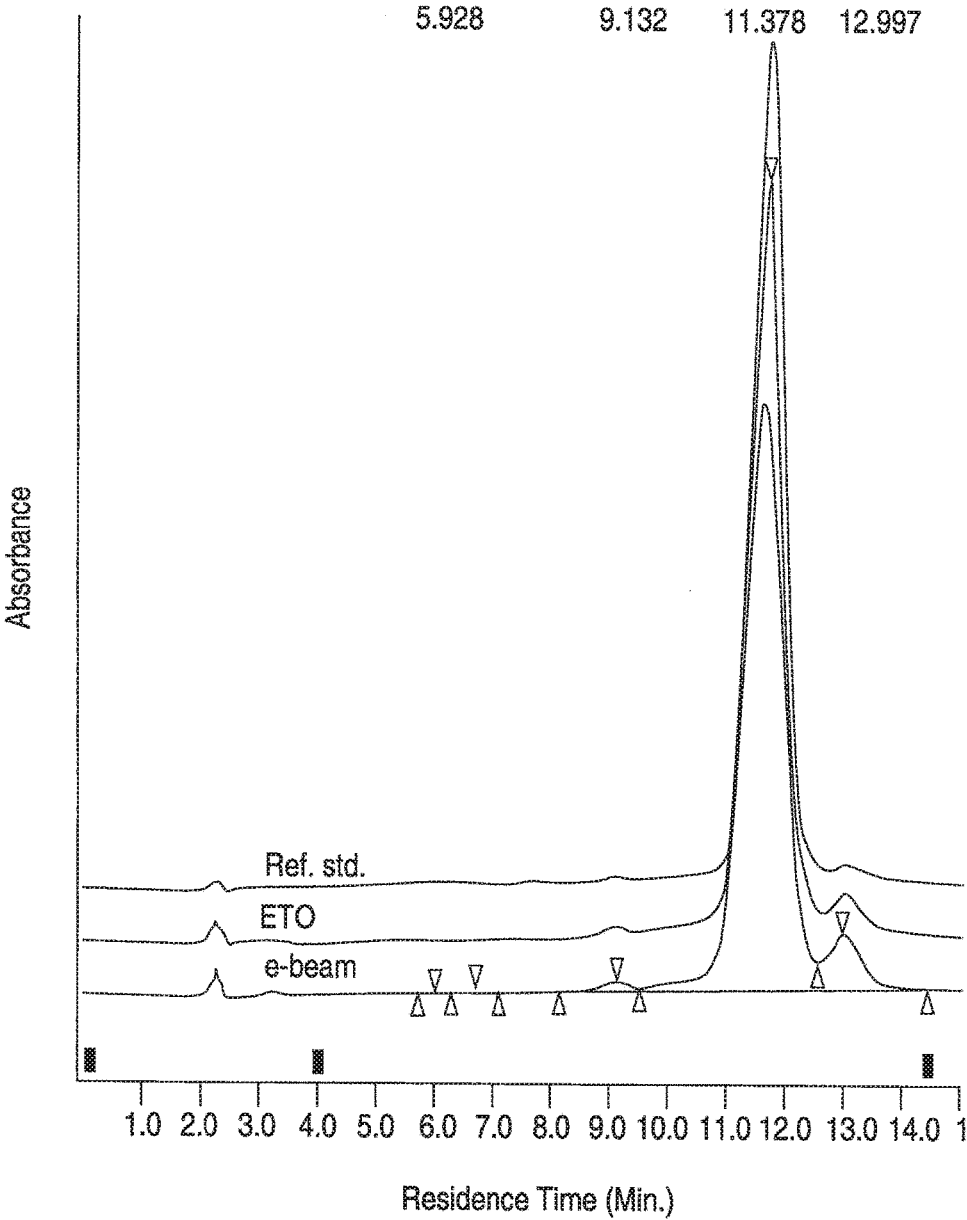

FIG. 4

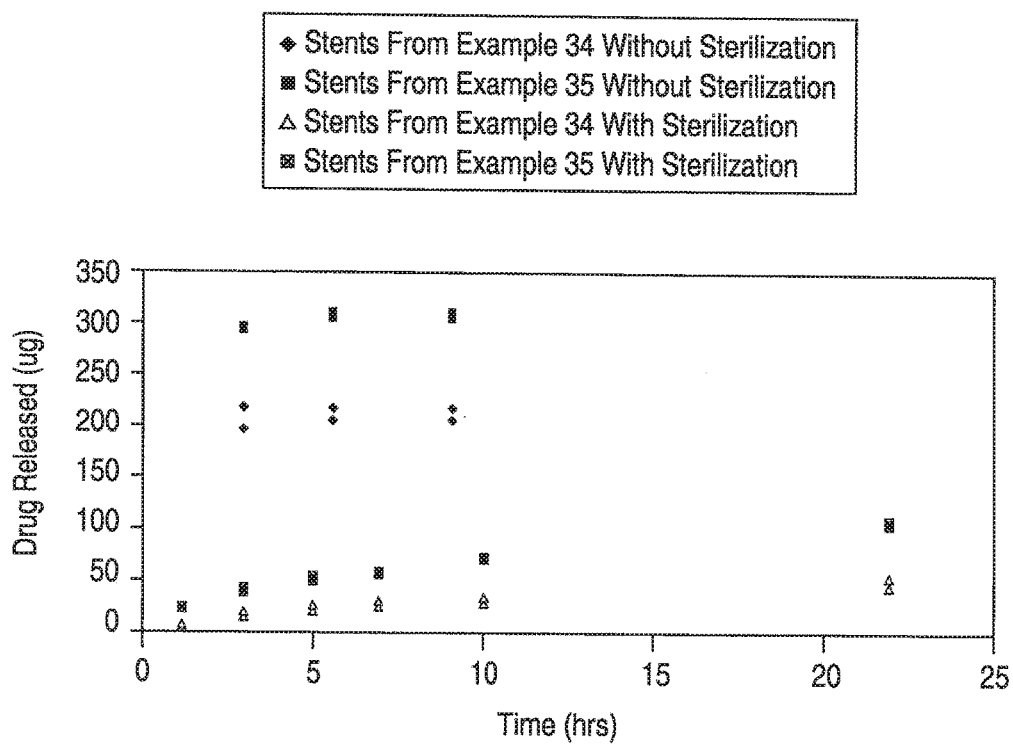

FIG. 5

40-O-(2-HYDROXY)ETHYL-RAPAMYCIN COATED STENT

BACKGROUND OF THE INVENTION

[0001] Field of the Invention

[0002] The invention relates to drug eluting implantable devices, one example of which is a stent. More particularly, the invention relates to sustained delivery of 40-O-(2-hydroxy)ethyl-rapamycin from a stent.

[0003] Description of the Background

[0004] Percutaneous transluminal coronary angioplasty (PTCA) is a procedure for treating heart disease. A catheter assembly having a balloon portion is introduced percutaneously into the cardiovascular system of a patient via the brachial or femoral artery. The catheter assembly is advanced through the coronary vasculature until the balloon portion is positioned across the occlusive lesion. Once in position across the lesion, the balloon is inflated to a predetermined size to remodel the vessel wall. The balloon is then deflated to a smaller profile to allow the catheter to be withdrawn from the patient's vasculature.

[0005] A problem associated with the above procedure includes formation of intimal flaps or torn arterial linings, which can collapse and occlude the conduit after the balloon is deflated. Vasospasms and recoil of the vessel wall also threaten vessel closure. Moreover, thrombosis and restenosis of the artery may develop over several months after the procedure, which may necessitate another angioplasty procedure or a surgical by-pass operation. To reduce the partial or total occlusion of the artery by the collapse of arterial lining and to reduce the chance of the development of thrombosis and restenosis, an expandable, intraluminal prosthesis, also known as a stent, is implanted in the lumen to maintain the vascular patency.

[0006] Stents act as scaffoldings, functioning to physically hold open and, if desired, to expand the wall of the passageway. Typically, stents are capable of being compressed so that they can be inserted through small lumens via catheters and then expanded to a larger diameter once they are at the desired location. Mechanical intervention via stents has reduced the rate of restenosis as compared to balloon angioplasty. Yet, restenosis is still a significant clinical problem with rates ranging from 20-40%. When restenosis does occur in the stented segment, its treatment can be challenging, as clinical options are more limited as compared to lesions that were treated solely with a balloon.

[0007] Stents are used not only for mechanical intervention but also as vehicles for providing biological therapy. Biological therapy can be achieved by medicating the stents. Medicated stents provide for the local administration of a therapeutic substance at the diseased site. In order to provide an efficacious concentration to the treated site, systemic administration of such medication often produces adverse or even toxic side effects for the patient. Local delivery is a preferred method of treatment in that smaller total levels of medication are administered in comparison to systemic dosages, but are concentrated at a specific site. Local delivery thus produces fewer side effects and achieves more favorable results.

[0008] One proposed method of medicating stents involves the use of a polymeric carrier coated onto the surface of the stent. A composition including a solvent, a polymer dissolved in the solvent, and a therapeutic substance dispersed in the blend is applied to the stent by

immersing the stent in the composition or by spraying the composition onto the stent. The solvent is allowed to evaporate, leaving on the stent strut surfaces a coating of the polymer and the therapeutic substance impregnated in the polymer.

[0009] A potential shortcoming of the foregoing method of medicating stents is that the release rate of the therapeutic substance may be too high to provide an efficacious treatment. This shortcoming may be especially pronounced with certain therapeutic substances. For instance, it has been found that the release rate of 40-O-(2-hydroxy)ethyl-rapamycin from a standard polymeric coating is greater than 50% in about 24 hours. Thus, there is a need for a coating that reduces the release rate of 40-O-(2-hydroxy)ethyl-rapamycin in order to provide a more efficacious release rate profile. The present invention provides a coating to meet this need.

SUMMARY

[0010] In accordance with one aspect of the invention, a stent is disclosed including a radially expandable body and a coating covering at least a portion of the body, the coating having 40-O-(2-hydroxy)ethyl-rapamycin, or an analog or derivative thereof, wherein the release rate of the 40-O-(2-hydroxy)ethyl-rapamycin, or the analog or derivative thereof, in 24 hours after the implantation of the stent is less than about 50% of the total amount contained in the coating.

[0011] In accordance with a further aspect of the present invention, a method of inhibiting or eliminating the development of restenosis following a stent placement procedure is disclosed including implanting a stent which can elude 40-O-(2-hydroxy)ethyl-rapamycin, or an analog or derivative thereof, at a release rate of less than 50% of the total amount of the drug carried by the stent in a 24 hour period following the implantation procedure.

[0012] In a further aspect, a method of providing drug delivery capability for a stent is disclosed including coating a stent with a polymer containing 40-O-(2-hydroxy)ethyl-rapamycin, or analog or derivative thereof, wherein the coating has an in vivo release rate of less than 50% of the total amount of the 40-O-(2-hydroxy)ethyl-rapamycin, or analog or derivative thereof, in a 24 hour period.

[0013] In yet another aspect of the present invention, a method of treating a polymeric coating on a stent to reduce the rate of release of the drug from the coating is disclosed including exposing the coating to a temperature of a sufficient degree to cause modifications in the structure of the polymer which allows for the reduction of the release rate of the drug through the polymer.

[0014] Also disclosed, in another aspect, is a method of treating a coated stent containing a therapeutic substance to reduce the rate of release of the therapeutic substance from the coating including subjecting the coating to a stimuli so as to change the property of at least a region of the coating such that the change of the property of the region of the coating causes the therapeutic substance to be released more slowly from the region that has the changed property.

[0015] In another aspect of the present invention, a method of preparing a coated stent containing 40-O-(2-hydroxy)ethyl-rapamycin, or analog or derivative thereof, for an implantation procedure is disclosed including sterilizing the stent while maintaining the peak purity of the 40-O-(2-hydroxy)ethyl-rapamycin, or analog or derivative thereof, at a level greater than 90%.

BRIEF DESCRIPTION OF THE FIGURES

[0016] FIGS. 1A-1C illustrate coatings deposited over an implantable medical substrate in accordance with various embodiments of the present invention;

[0017] FIGS. 2-3 are graphs showing the release rate of 40-O-(2-hydroxy)ethyl-rapamycin from stent coatings in accordance with embodiments of the present invention;

[0018] FIG. 4 is a chromatograph as referred to in Examples 32 and 33; and

[0019] FIG. 5 is a graph showing the release rate of 40-O-(2-hydroxy)ethyl-rapamycin from stent coatings in accordance with an embodiment of the present invention.

DETAILED DESCRIPTION

Forming an Active Ingredient-Containing Coating

[0020] Herein is disclosed a method of forming a coating for an implantable device including applying a first composition with 40-O-(2-hydroxy)ethyl-rapamycin, or a functional analog or structural derivative thereof, to at least a portion of an implantable device to form a first layer. The release rate of 40-O-(2-hydroxy)ethyl-rapamycin is advantageously controlled by various methods and coatings as described below. In particular, by using the methods and coatings of the present invention, the release rate of the 40-O-(2-hydroxy)ethyl-rapamycin, or analog or derivative thereof, can be less than about 50% in 24 hours.

[0021] 40-O-(2-hydroxy)ethyl-rapamycin is an immunosuppressant which is under investigation primarily for use with cyclosporine/steroids to prevent acute rejection episodes in renal transplant recipients. 40-O-(2-hydroxy)ethyl-rapamycin is also under investigation for rejection prophylaxis following other types of transplantation (e.g., lung, liver). The chemical structure for 40-O-(2-hydroxy)ethyl-rapamycin is as follows:

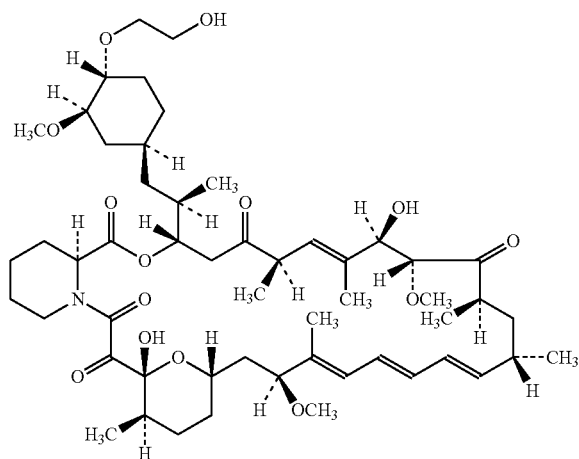

Examples of analogs or derivatives of 40-O-(2-hydroxy)ethyl-rapamycin include but are not limited to 40-O-(3-hydroxy)propyl-rapamycin and 40-O-[2-(2-hydroxy)ethoxy]ethyl-rapamycin.

[0022] 40-O-(2-hydroxy)ethyl-rapamycin binds to the cytosolic immunophilin FKBP12 and inhibits growth factor-driven cell proliferation, including that of T-cells and vascular smooth muscle cells. The actions of 40-O-(2-

hydroxy)ethyl-rapamycin occur late in the cell cycle (i.e., late G1 stage) compared to other immunosuppressive agents such as tacrolimus or cyclosporin which block transcriptional activation of early T-cell-specific genes. Since 40-O-(2-hydroxy)ethyl-rapamycin can act as a potent anti-proliferative agent, it is believed that 40-O-(2-hydroxy)ethyl-rapamycin can be an effective agent to treat restenosis by being delivered to a local treatment site from a polymeric coated implantable device such as a stent.

[0023] The composition including 40-O-(2-hydroxy)ethyl-rapamycin can be applied to the implantable device in various ways. In one embodiment, a first layer can be formed on the implantable device by (1) immersing the implantable device into a solution containing 40-O-(2-hydroxy)ethyl-rapamycin dissolved in a suitable solvent, or (2) spray coating the implantable device with the same solution containing 40-O-(2-hydroxy)ethyl-rapamycin to form a reservoir layer. In this embodiment, the implantable device can include cavities or micro-pores for containing the 40-O-(2-hydroxy)ethyl-rapamycin.

[0024] The 40-O-(2-hydroxy)ethyl-rapamycin can also be blended with a polymer and applied to the implantable device to form the reservoir layer. "Polymer," "poly" and "polymeric" are defined as compounds that are the product of a polymerization reaction and are inclusive of homopolymers, copolymers, terpolymers etc., including random, alternating, block, and graft variations thereof. The polymers should have a high capacity of adherence to the surface of an implantable device, such as a metallic surface of a stent, and a high capacity of adherence to polymeric surfaces.

[0025] In accordance with one embodiment, when the 40-O-(2-hydroxy)ethyl-rapamycin is blended with a polymer for the reservoir layer, the ratio of 40-O-(2-hydroxy)ethyl-rapamycin, or analog or derivative thereof, to polymer by weight in the reservoir layer is about 1:2.8 to about 1:1. It has been found that this particular range of 40-O-(2-hydroxy)ethyl-rapamycin:polymer ratio provides a beneficial release rate of the 40-O-(2-hydroxy)ethyl-rapamycin from the polymer matrix.

[0026] In accordance with another embodiment, when the 40-O-(2-hydroxy)ethyl-rapamycin is blended with a polymer for the reservoir layer, the 40-O-(2-hydroxy)ethyl-rapamycin, or analog or derivative thereof, is in the amount of about 50 μ g to about 500 μ g, more narrowly about 90 μ g to about 350 μ g, and the polymer is in the amount of about 50 μ g to about 1000 μ g, more narrowly about 90 μ g to about 500 μ g. These particular ranges of amounts for 40-O-(2-hydroxy)ethyl-rapamycin and a polymer can provide a beneficial release rate of the 40-O-(2-hydroxy)ethyl-rapamycin from the polymer matrix.

[0027] When the polymer solution is being prepared, a predetermined amount of a polymer can be added to a predetermined amount of a compatible solvent. "Solvent" is defined as a liquid substance or composition that is compatible with the components of the composition and is capable of dissolving the component(s) at the concentration desired in the composition. Representative examples of solvents include chloroform, acetone, water (buffered saline), dimethylsulfoxide (DMSO), propylene glycol methyl ether (PM), iso-propylalcohol (IPA), n-propylalcohol, methanol, ethanol, tetrahydrofuran (THF), dimethylformamide (DMF), dimethylacetamide (DMAC), benzene, toluene, xylene, hexane, cyclohexane, pentane, heptane,

octane, nonane, decane, decalin, ethyl acetate, butyl acetate, isobutyl acetate, isopropyl acetate, butanol, diacetone alcohol, benzyl alcohol, 2-butanone, cyclohexanone, dioxane, methylene chloride, carbon tetrachloride, tetrachloroethylene, tetrachloro ethane, chlorobenzene, 1,1,1-trichloroethane, formamide, hexafluoroisopropanol, 1,1,1-trifluoroethanol, and hexamethyl phosphoramidate and a combination thereof.

[0028] The polymer can be added to the solvent at ambient pressure and under anhydrous atmosphere. If necessary, gentle heating and stirring and/or mixing can be employed to effect dissolution of the polymer into the solvent, for example 12 hours in a water bath at about 60° C.

[0029] Sufficient amounts of 40-O-(2-hydroxy)ethyl-rapamycin can then be dispersed in the blended composition of the polymer and the solvent. The polymer can comprise from about 0.1% to about 35%, more narrowly from about 0.5% to about 20% by weight of the total weight of the composition, the solvent can comprise from about 59.9% to about 99.8%, more narrowly from about 79% to about 99% by weight of the total weight of the composition, and the 40-O-(2-hydroxy)ethyl-rapamycin can comprise from about 0.1% to about 40%, more narrowly from about 1% to about 9% by weight of the total weight of the composition. More than 9% by weight of the 40-O-(2-hydroxy)ethyl-rapamycin could adversely affect characteristics that are desirable in the polymeric coating, such as adhesion of the coating to the device. With the use of the optional primer layer, weight ratios of more than 9% for the active ingredient are achievable without compromising the effectiveness of the adhesion. Selection of a specific weight ratio of the polymer and solvent is dependent on factors such as, but not limited to, the material from which the device is made, the geometrical structure of the device, and the type and amount of the active ingredient employed.

[0030] Optionally, a second solvent, such as tetrahydrofuran (THF) or dimethylformamide (DMF), can be used to improve the solubility of the 40-O-(2-hydroxy)ethyl-rapamycin in the composition. The second solvent can be added to the composition or the 40-O-(2-hydroxy)ethyl-rapamycin can be added to the second solvent prior to mixture with the blend.

[0031] The 40-O-(2-hydroxy)ethyl-rapamycin should be in true solution or saturated in the blended composition. If the 40-O-(2-hydroxy)ethyl-rapamycin is not completely soluble in the composition, operations including mixing, stirring, and/or agitation can be employed to effect homogeneity of the residues. The 40-O-(2-hydroxy)ethyl-rapamycin can also be first added to the second solvent prior to admixing with the composition. The 40-O-(2-hydroxy)ethyl-rapamycin may be added so that the dispersion is in fine particles.

[0032] Representative examples of polymers that can be combined with 40-O-(2-hydroxy)ethyl-rapamycin for the reservoir layer include ethylene vinyl alcohol copolymer (commonly known by the generic name EVOH or by the trade name EVAL), poly(hydroxyvalerate); poly(L-lactic acid); polycaprolactone; poly(lactide-co-glycolide); poly(hydroxybutyrate); poly(hydroxybutyrate-co-valerate); polydioxanone; polyorthoester; polyanhydride; poly(glycolic acid); poly(D,L-lactic acid); poly(glycolic acid-co-trimethylene carbonate); polyphosphoester; polyphosphoester urethane; poly(amino acids); cyanoacrylates; poly(trimethylene carbonate); poly(iminocarbonate); copoly

(ether-esters) (e.g. PEO/PLA); polyalkylene oxalates; polyphosphazenes; biomolecules, such as fibrin, fibrinogen, cellulose, starch, collagen and hyaluronic acid; polyurethanes; silicones; polyesters; polyolefins; polyisobutylene and ethylene-alphaolefin copolymers; acrylic polymers and copolymers; vinyl halide polymers and copolymers, such as polyvinyl chloride; polyvinyl ethers, such as polyvinyl methyl ether; polyvinylidene halides, such as polyvinylidene fluoride and polyvinylidene chloride; polyacrylonitrile; polyvinyl ketones; polyvinyl aromatics, such as polystyrene; polyvinyl esters, such as polyvinyl acetate; copolymers of vinyl monomers with each other and olefins, such as ethylene-methyl methacrylate copolymers, acrylonitrile-styrene copolymers, ABS resins, and ethylene-vinyl acetate copolymers; polyamides, such as Nylon 66 and polycaprolactam; alkyd resins; polycarbonates; polyoxymethylenes; polyamides; polyethers; epoxy resins; polyurethanes; rayon; rayon-triacetate; cellulose acetate; cellulose butyrate; cellulose acetate butyrate; cellophane; cellulose nitrate; cellulose propionate; cellulose ethers; and carboxymethyl cellulose.

[0033] Ethylene vinyl alcohol is functionally a very suitable choice of polymer. Ethylene vinyl alcohol copolymer refers to copolymers comprising residues of both ethylene and vinyl alcohol monomers. One of ordinary skill in the art understands that ethylene vinyl alcohol copolymer may also be a terpolymer so as to include small amounts of additional monomers, for example less than about five (5) mole percentage of styrenes, propylene, or other suitable monomers. Ethylene vinyl alcohol copolymers are available commercially from companies such as Aldrich Chemical Company, Milwaukee, Wis., or EVAL Company of America, Lisle, Ill., or can be prepared by conventional polymerization procedures that are well known to one of ordinary skill in the art.

[0034] The copolymer of EVAL allows for good control capabilities of the release rate of the 40-O-(2-hydroxy)ethyl-rapamycin. As a general rule, an increase in the amount of the ethylene comonomer content decreases the rate that the 40-O-(2-hydroxy)ethyl-rapamycin is released from the copolymer matrix. The release rate of the 40-O-(2-hydroxy)ethyl-rapamycin typically decreases as the hydrophilicity of the copolymer decreases. An increase in the amount of the ethylene comonomer content increases the overall hydrophobicity of the copolymer, especially as the content of vinyl alcohol is concomitantly reduced. It is also thought that the release rate and the cumulative amount of the active ingredient that is released is directly proportional to the total initial content of the ingredient in the copolymer matrix. Accordingly, a wide spectrum of release rates can be achieved by modifying the ethylene comonomer content and the initial amount of the 40-O-(2-hydroxy)ethyl-rapamycin.

[0035] Besides 40-O-(2-hydroxy)ethyl-rapamycin, another active agent can also be added to the first composition. The additional active agent may be any substance capable of exerting a therapeutic or prophylactic effect in the practice of the present invention. Examples of such active agents include antiproliferative, antineoplastic, antiinflammatory, antiplatelet, anticoagulant, antifibrin, antithrombin, antimetabolic, antibiotic, and antioxidant substances as well as combinations thereof. A suitable example of an antiproliferative substance is actinomycin D, or derivatives and analogs thereof (manufactured by Sigma-Aldrich 1001 West Saint Paul Avenue, Milwaukee, Wis. 53233; or COSMEGEN available from Merck). Synonyms of actinomycin D include dactinomycin, actinomycin IV, actinomycin I,

actinomycin X₁, and actinomycin C₁. Examples of suitable antineoplastics include paclitaxel and docetaxel. Examples of suitable antiplatelets, anticoagulants, antifibrins, and anti-thrombins include aspirin, sodium heparin, low molecular weight heparin, hirudin, argatroban, forskolin, vapiprost, prostacyclin and prostacyclin analogs, dextran, D-phe-pro-arg-chloromethylketone (synthetic antithrombin), dipyridamole, glycoprotein IIb/IIIa platelet membrane receptor antagonist, recombinant hirudin, thrombin inhibitor (available from Biogen), and 7E-3B® (an antiplatelet drug from Centocor). Examples of suitable antimitotic agents include methotrexate, azathioprine, vincristine, vinblastine, fluorouracil, adriamycin, and mutamycin. Examples of suitable cytostatic or antiproliferative agents include angiopeptin (a somatostatin analog from Ibsen), angiotensin converting enzyme inhibitors such as CAPTOPRIL, (available from Squibb), CILAZAPRIL (available from Hoffman-LaRoche), or LISINOPRIL (available from Merck & Co., Whitehouse Station, N.J.); calcium channel blockers (such as Nifedipine), colchicine, fibroblast growth factor (FGF) antagonists, histamine antagonist, LOVASTATIN (an inhibitor of HMG-CoA reductase, a cholesterol lowering drug from Merck & Co.), monoclonal antibodies (such as PDGF receptors), nitroprusside, phosphodiesterase inhibitors, prostaglandin inhibitor (available from Glazo), Seramin (a PDGF antagonist), serotonin blockers, thioprotease inhibitors, triazolopyrimidine (a PDGF antagonist), and nitric oxide. Other therapeutic substances or agents that may be appropriate include alpha-interferon; genetically engineered epithelial cells; dexamethasone; rapamycin; estradiol; clobetasol propionate; cisplatin; insulin sensitizers; receptor tyrosine kinase inhibitors; and carboplatin. Exposure of the composition to the active ingredient should not adversely alter the active ingredient's composition or characteristic. Accordingly, the particular active ingredient is selected for compatibility with the blended composition.

[0036] The dosage or concentration of 40-O-(2-hydroxy)ethyl-rapamycin or other active agent required to produce a therapeutic effect should be less than the level at which the 40-O-(2-hydroxy)ethyl-rapamycin or other active agent produces unwanted toxic effects and greater than the level at which non-therapeutic results are obtained. The dosage or concentration of 40-O-(2-hydroxy)ethyl-rapamycin or other active agent required to inhibit the desired cellular activity of the vascular region, for example, can depend upon factors such as the particular circumstances of the patient; the nature of live trauma; the nature of the therapy desired; the time over which the ingredient administered resides at the vascular site; and if other bioactive substances are employed, the nature and type of the substance or combination of substances. Therapeutically effective dosages can be determined empirically, for example by infusing vessels from suitable animal model systems and using immunohistochemical, fluorescent or electron microscopy methods to detect the agent and its effects, or by conducting suitable *in vitro* studies. Standard pharmacological test procedures to determine dosages are understood by one of ordinary skill in the art.

Forming a Barrier Layer to Reduce the Rate of Release

[0037] In some coatings, the release rate of the 40-O-(2-hydroxy)ethyl-rapamycin may be too high to be clinically useful. For example, in Example 22 below, the percentage of

40-O-(2-hydroxy)ethyl-rapamycin in released from a stent coating without a barrier layer in 24 hours was determined to be 58.55 as measured in a porcine serum release rate procedure. The release rate from the coating of Example 22 may be too high for a treatment using 40-O-(2-hydroxy)ethyl-rapamycin as the active agent. The barrier layer of the present invention can reduce the rate of release or delay the time at which the 40-O-(2-hydroxy)ethyl-rapamycin is released from the reservoir layer.

[0038] In accordance with one embodiment, the barrier layer can be applied on a selected region of the reservoir layer to form a rate reducing member. The composition for the barrier layer can be substantially free of active agents. Alternatively, for maximum blood compatibility, compounds such as polyethylene glycol, heparin, heparin derivatives having hydrophobic counterions, or polyethylene oxide can be added to the barrier layer.

[0039] The choice of polymer for the barrier layer can be the same as the selected polymer for the reservoir. The use of the same polymer, as described for some of the embodiments, significantly reduces or eliminates any interfacial incompatibilities, such as lack of adhesion, which may exist in the employment of two different polymeric layers.

[0040] Representative examples of polymers that can be used for a barrier layer can include polytetrafluoroethylene, perfluoro elastomers, ethylene-tetrafluoroethylene copolymer, fluoroethylene-alkyl vinyl ether copolymer, polyhexafluoropropylene, low density linear polyethylenes having high molecular weights, ethylene-olefin copolymers, atactic polypropylene, polyisobutene, polybutylenes, polybutenes, styrene-ethylene-styrene block copolymers, styrene-butylene-styrene block copolymers, styrene-butadiene-styrene block copolymers, and ethylene methacrylic acid copolymers of low methacrylic acid content.

[0041] Ethylene vinyl alcohol is functionally a very suitable choice of polymer. The copolymer allows for good control capabilities over the release rate of the 40-O-(2-hydroxy)ethyl-rapamycin. As a general rule, an increase in the amount of the ethylene comonomer content decreases the rate that the 40-O-(2-hydroxy)ethyl-rapamycin is released from the copolymer matrix. The release rate of the 40-O-(2-hydroxy)ethyl-rapamycin decreases as the hydrophilicity of the polymer decreases. An increase in the amount of the ethylene comonomer content increases the overall hydrophobicity of the copolymer, especially as the content of vinyl alcohol is concomitantly reduced.

[0042] Fluoropolymers are also a suitable choice for the barrier layer composition. For example, polyvinylidene fluoride (otherwise known as KYNAR, available from ATOFINA Chemicals, Philadelphia, Pa.) can be dissolved in HFE FLUX REMOVER (Techspray, Amarillo, Tex.) and can optionally be combined with EVAL to form the barrier layer composition. Also, solution processing of fluoropolymers is possible, particularly the low crystallinity varieties such as CYTOP available from Asahi Glass and TEFLON AF available from DuPont. Solutions of up to about 15% (wt/wt) are possible in perfluoro solvents, such as FC-75 (available from 3M under the brand name FLUORINERT), which are non-polar, low boiling solvents. Such volatility allows the solvent to be easily and quickly evaporated following the application of the polymer-solvent solution to the implantable device.

[0043] In one embodiment, polybutylmethacrylate can be used for the barrier layer. Polybutylmethacrylate, for

example, can be dissolved in a solution of xylene, acetone and HFE FLUX REMOVER.

[0044] The barrier layer can also be styrene-ethylene/butylene-styrene block copolymer. Styrene-ethylene/butylene-styrene block copolymer, e.g., Kraton G-series, can be dissolved in non-polar solvents such as, but not limited to, toluene, xylene, and decalin.

[0045] Other choices of polymers for the rate-limiting membrane include, but are not limited to, ethylene-anhydride copolymers; ethylene vinyl acetate copolymers having, for example, a mol % of vinyl acetate of from about 9% to about 25%; and ethylene-acrylic acid copolymers having, for example, a mol % of acrylic acid of from about 2% to about 25%. The ethylene-anhydride copolymer available from Bynel adheres well to EVAL and thus would function well as a barrier layer over a reservoir layer made from EVAL. The copolymer can be dissolved in organic solvents, such as dimethylsulfoxide and dimethylacetamide. Ethylene vinyl acetate polymers can be dissolved in organic solvents, such as toluene and n-butyl acetate. Ethylene-acrylic acid copolymers can be dissolved in organic solvents, such as methanol, isopropyl alcohol, and dimethylsulfoxide.

[0046] Yet another choice of polymer for the rate-limiting membrane is a cross-linked silicone elastomer. Loose silicone and silicone with very low cross-linking are thought to cause an inflammatory biological response. However, it is believed that a thoroughly cross-linked silicone elastomer, having low levels of leachable silicone polymer and oligomer, is an essentially non-inflammatory substance. Silicone elastomers, such as Nusil MED-4750, MED-4755, or MED2-6640, having high tensile strengths, for example between 1200 psi and 1500 psi, will likely have the best durability during crimping, delivery, and expansion of a stent as well as good adhesion to a reservoir layer, e.g., EVAL or the surface of an implantable device.

[0047] The embodiments of the composition for a rate-reducing membrane or diffusion barrier layer are prepared by methods wherein all components are combined, then blended. More particularly, a predetermined amount of a polymer can be added to a predetermined amount of a compatible solvent. The selected solvent should be capable of placing the polymer into solution at the concentration desired.

[0048] The polymer can be added to the solvent at ambient pressure and under anhydrous atmosphere. If necessary, gentle heating and stirring and/or mixing can be employed to effect dissolution of the polymer into the solvent, for example 12 hours in a water bath at about 60° C. The polymer can comprise from about 0.1% to about 35%, more narrowly from about 1% to about 20% by weight of the total weight of the composition, and the solvent can comprise from about 65% to about 99.9%, more narrowly from about 80% to about 98% by weight of the total weight of the composition. Selection of a specific weight ratio of the polymer and solvent is dependent on factors such as, but not limited to, the type of polymer and solvent employed, the type of underlying reservoir layer, and the method of application.

[0049] In an embodiment, the barrier layer contains a polymer in the amount of about 25 µg to about 500 µg, more narrowly about 65 µg to about 350 µg. This particular range for the amount of barrier polymer can provide a beneficial release rate of the 40-O-(2-hydroxy)ethyl-rapamycin from the polymer matrix.

Forming a Primer Layer

[0050] The presence of an active ingredient in a polymeric matrix can interfere with the ability of the matrix to adhere effectively to the surface of the device. Increasing the quantity of the active ingredient reduces the effectiveness of the adhesion. High drug loadings in the coating can hinder the retention of the coating on the surface of the device. A primer layer can serve as a functionally useful intermediary layer between the surface of the device and an active ingredient-containing or reservoir coating. The primer layer provides an adhesive tie between the reservoir coating and the device—which, in effect, would also allow for the quantity of the active ingredient in the reservoir coating to be increased without compromising the ability of the reservoir coating to be effectively contained on the device during delivery and, if applicable, expansion of the device.

[0051] The composition for a primer layer is prepared by conventional methods wherein all components are combined, then blended. More particularly, a predetermined amount of a polymer or a prepolymer can be added to a predetermined amount of a solvent or a combination of solvents. The mixture can be prepared at ambient pressure and under anhydrous atmosphere. Heating and stirring and/or mixing can be employed to effect dissolution of the polymer into the solvent.

[0052] Representative examples of suitable polymers for the primer layer include, but are not limited to, polyisocyanates, such as triisocyanurate and polyisocyanate polyether polyurethanes based on diphenylmethane diisocyanate; acrylates, such as copolymers of ethyl acrylate and methacrylic acid; titanates, such as tetra-isopropyl titanate and tetra-n-butyl titanate; zirconates, such as n-propyl zirconate and n-butyl zirconate; silane coupling agents, such as 3-aminopropyltriethoxysilane and (3-glycidoxypropyl) methyl diethoxysilane; high amine content polymers, such as polyethyleneamine, polyallylamine, and polylysine; polymers with a high content of hydrogen bonding groups, such as polyethylene-co-polyvinyl alcohol, ethylene vinyl acetate, and melamine formaldehydes; and unsaturated polymers and prepolymers, such as polycaprolactone diacrylates, polyacrylates with at least two acrylate groups, and polyacrylated polyurethanes. With the use of unsaturated prepolymers, a free radical or UV initiator can be added to the composition for the thermal or UV curing or cross-linking process, as is understood by one of ordinary skill in the art.

[0053] Representative examples of polymers that can be used for the primer material also include those polymers that can be used for the reservoir layer as described above. The use of the same polymer significantly reduces or eliminates any interfacial incompatibilities, such as lack of an adhesive tie or bond, which may exist with the employment of two different polymeric layers.

[0054] Ethylene vinyl alcohol is a very suitable choice of polymer for the primer layer. The copolymer possesses good adhesive qualities to the surface of a stent, particularly stainless steel surfaces, and has illustrated the ability to expand with a stent without any significant detachment of the copolymer from the surface of the stent. The copolymer can comprise a mole percent of ethylene of from about 27% to about 48%.

[0055] By way of example, and not limitation, the polymer can comprise from about 0.1% to about 35%, more narrowly from about 1% to about 20% by weight of the total weight of the composition, and the solvent can comprise from about

65% to about 99.9%, more narrowly from about 80% to about 98% by weight of the total weight of the primer composition. A specific weight ratio is dependent on factors such as the material from which the implantable device is made, the geometrical structure of the device, the choice of polymer-solvent combination, and the method of application.

[0056] In accordance with another embodiment, a fluid can be added to the composition to enhance the wetting of the primer composition for a more uniform coating application. To enhance the wetting of the composition, a suitable fluid typically has a high capillary permeation. Capillary permeation or wetting is the movement of a fluid on a solid substrate driven by interfacial energetics. Capillary permeation is quantitated by a contact angle, defined as an angle at the tangent of a droplet in a fluid phase that has taken an equilibrium shape on a solid surface. A low contact angle indicates a higher wetting liquid. A suitably high capillary permeation corresponds to a contact angle less than about 90°. The wetting fluid, typically, should have a viscosity not greater than about 50 centipoise, narrowly about 0.3 to about 5 centipoise, more narrowly about 0.4 to about 2.5 centipoise. The wetting fluid, accordingly, when added to the composition, reduces the viscosity of composition.

[0057] The wetting fluid should be compatible with the polymer and the solvent and should not precipitate the polymer. The wetting fluid can also act as the solvent. Useful examples of the wetting fluid include, but are not limited to, tetrahydrofuran (THF), dimethylformamide (DMF), 1-butanol, n-butyl acetate, dimethyl acetamide (DMAC), and mixtures and combinations thereof.

Forming a Finishing Layer

[0058] Depending on the polymer used for the reservoir or barrier layers, it may be advantageous to form a finishing layer that is especially biocompatible on the surface of the coating that is exposed to the biological lumen when inserted into a patient. Representative examples of suitable biocompatible polymers or biocompatible agents for the finishing layer include, but are not limited to ethylene vinyl alcohol copolymer, polyethylene oxide, polyethylene glycol, hyaluronic acid, polyvinyl pyrrolidone, heparin, heparin derivatives such as those having hydrophobic counterions, and phosphylcholine.

Methods for Applying the Compositions to the Device

[0059] Application of the composition can be by any conventional method, such as by spraying the composition onto the prosthesis or by immersing the prosthesis in the composition. Operations such as wiping, centrifugation, blowing, or other web-clearing acts can also be performed to achieve a more uniform coating. Briefly, wiping refers to physical removal of excess coating from the surface of the stent; centrifugation refers to rapid rotation of the stent about an axis of rotation; and blowing refers to application of air at a selected pressure to the deposited coating. Any excess coating can also be vacuumed off the surface of the device. The addition of a wetting fluid leads to a consistent application of the composition which also causes the coating to be uniformly deposited on the surface of the prosthesis.

[0060] With the use of the thermoplastic polymers for the primer, such as ethylene vinyl alcohol copolymer, poly-

caprolactone, poly(lactide-co-glycolide), poly(hydroxybutyrate), etc., the deposited primer composition should be exposed to a heat treatment at a temperature range greater than about the glass transition temperature (T_g) and less than about the melting temperature (T_m) of the selected polymer. Unexpected results have been discovered with treatment of the composition under this temperature range, specifically strong adhesion or bonding of the coating to the metallic surface of a stent. The device should be exposed to the heat treatment for any suitable duration of time that would allow for the formation of the primer coating on the surface of the device as well as for the evaporation of the solvent or combination of solvent and wetting fluid. It is understood that essentially all of the solvent and the wetting fluid will be removed from the composition, but traces or residues may remain blended with the polymer.

[0061] Table 1 lists the T_g and T_m for some of the polymers used in the embodiments of the present invention. T_g and T_m of polymers are attainable by one of ordinary skill in the art. The cited exemplary temperature and time for exposure are provided by way of illustration and are not meant to be limiting.

TABLE 1

Polymer	T_g (° C.)	T_m (° C.)	Exemplary Temperature (° C.)	Exemplary Duration of Time For Heating
EVAL	55	165	140	4 hours
polycaprolactone	-60	60	50	2 hours
ethylene vinyl acetate (e.g., 33% vinyl acetate content)	36	63	45	2 hours
Polyvinyl alcohol	75-85*	200-220*	165	2 hours

*Exact temperature depends on the degree of hydrolysis which is also known as the amount of residual acetate.

[0062] With the use of one of the aforementioned thermoset primer polymers, the use of initiators may be required. By way of example, epoxy systems consisting of diglycidyl ether of bisphenol A resins can be cured with amine curatives, thermoset polyurethane prepolymers can be cured with polyols, polyamines, or water (moisture), and acrylated urethane can be cured with UV light. If baked, the temperature can be above the T_g of the selected polymer.

[0063] With the use of the inorganic primer polymers, such as silanes, titanates, and zirconates, the solvent is allowed to evaporate.

[0064] The composition containing the active ingredient can be applied to a designated region of the primer coating or the surface of the device. The solvent(s) or the combination of solvent(s) and the wetting fluid is removed from the composition by allowing the solvent(s) or combination of the solvent(s) and the wetting fluid to evaporate. The evaporation can be induced by heating the device at a predetermined temperature for a predetermined period of time. For example, the device can be heated at a temperature of about 60° C. for about 12 hours to about 24 hours. The heating can be conducted in an anhydrous atmosphere and at ambient pressure and should not exceed the temperature which would adversely affect the active ingredient. The heating can also be conducted under a vacuum condition. It is understood that essentially all of the solvent and the

wetting fluid will be removed from the composition, but traces or residues may remain blended with the polymer.

[0065] The diffusion barrier layer can be formed on a designated region of the active ingredient-containing coating subsequent to the evaporation of the solvent(s) or solvent(s)/wetting fluid and the drying of the polymer for the active ingredient-containing coating. Alternatively, in embodiments in which a polymeric reservoir coating is not employed, the rate-reducing membrane may be formed directly over active-ingredient containing cavities within the surface of the prosthesis. The diffusion barrier layer can be applied by spraying the composition onto the device or immersing the device in the composition, then drying the polymer. The above-described processes can be similarly repeated for the formation of the diffusion barrier layer.

Thermal Treatment of the Coating

[0066] After the coating has been formed on the implantable device, depending on the polymers used in the coating, the 40-O-(2-hydroxy)ethyl-rapamycin can diffuse from the polymer matrix at a rate that could be too high for certain clinical conditions. Accordingly, the coating can be exposed to a temperature that is effective to decrease the diffusion rate of the 40-O-(2-hydroxy)ethyl-rapamycin from the polymer matrix. In particular, the coating can be exposed to a sufficient temperature effective to decrease the release rate of the 40-O-(2-hydroxy)ethyl-rapamycin, or analog or derivative thereof, by about 50% as compared to a control group, as demonstrated in Example 17 below.

[0067] Typically, the temperature will be between the glass transition temperature (T_g) and the melting temperature (T_m) of the polymer. For example, the temperature can be the annealing temperature of the polymer (about equal to $T_g + T_m/2$). The thermal treatment can be conducted in an anhydrous atmosphere and at ambient pressure. The treatment can also be conducted under a vacuum condition.

[0068] The exposure temperature should not adversely affect the characteristics of the 40-O-(2-hydroxy)ethyl-rapamycin or other active agents present in the coating. In order to prevent possible degradation of the active agents or the polymers in the coating, additives can be mixed with the polymer before or during the coating process to shift the thermal profile of the polymer (i.e., decrease the T_g and T_m of the polymer). For example, a plasticizer, which is usually a low molecular weight nonvolatile molecule, can be dissolved with the polymer before the application process. The plasticizer can be an active agent. A representative example of an additive is dioctyl phthalate.

[0069] In one embodiment, one of the polymers in the coating exposed to the temperature is a semi-crystalline (e.g., polyvinyl chloride and EVAL) polymer. Without being bound by any particular theory, it is believed that the diffusion rate of the active agent from the polymer is decreased because the thermal radiation increases the percent crystallinity of the polymer. Others types of energy, such as RF energy, can also be used to increase the percent crystallinity. "Percent crystallinity" refers to the percentage of the polymer material that is in a crystalline form. Those of ordinary skill in the art understand that there are several methods for determining the percent crystallinity in polymers. These methods are, for example, described in L. H. Sperline, Introduction to Physical Polymer Science (3rd ed. 2001). The first involves the determination of the heat of fusion of the whole sample by calorimetric methods. The

heat of fusion per mole of crystalline material can be estimated independently by melting point depression experiments.

[0070] A second method involves the determination of the density of the crystalline portion via X-ray analysis of the crystal structure, and determining the theoretical density of a 100% crystalline material. The density of the amorphous material can be determined from an extrapolation of the density from the melt to the temperature of interest. Then the percent crystallinity is given by:

$$\% \text{ Crystallinity} = \frac{\rho_{\text{expt}} - \rho_{\text{amorph}}}{\rho_{100\% \text{ cryst}} - \rho_{\text{amorph}}} \times 100$$

where ρ_{expt} represents the experimental density, and ρ_{amorph} and $\rho_{100\% \text{ cryst}}$ are the densities of the amorphous and crystalline portions, respectively.

[0071] A third method stems from the fact that X-ray diffraction depends on the number of electrons involved and is thus proportional to the density. Besides Bragg diffraction lines for the crystalline portion, there is an amorphous halo caused by the amorphous portion of the polymer. The amorphous halo occurs at a slightly smaller angle than the corresponding crystalline peak, because the atomic spacings are larger. The amorphous halo is broader than the corresponding crystalline peak, because of the molecular disorder. This third method can be quantified by the crystallinity index, CI, where

$$CI = \frac{A_c}{A_a + A_c}$$

and where A_c and A_a represent the area under the Bragg diffraction line and corresponding amorphous halo, respectively.

[0072] The heat emitter used to thermal treat the coating can be any apparatus that emits thermal radiation. For example, the heat emitter can be a cauterizer tip. The heat emitter can also be a blower that includes a heating device so that the blower can direct a warm gas (e.g., air, argon or nitrogen) onto the implantable device. The heating device can be any heating device as known by those of ordinary skill in the art. For example, the heating device can be an electric heater incorporating heating coils.

[0073] In one embodiment of the present invention, the thermal radiation from the heat emitter can be directed to only certain portions of the implantable device or only for certain durations so that the diffusion rates of the 40-O-(2-hydroxy)ethyl-rapamycin from the polymer differs in various portions of the coating. In one example, the implantable device can have two or more segments along the longitudinal axis of the implantable device, such as a first segment, a second segment and a third segment. The thermal radiation could be directed substantially only at the first segment and the third segment, for instance, by using a cauterizer tip. Alternatively, the thermal radiation could be set higher for the first and third segments, or the thermal radiation could be directed at the first and third segments for a longer duration than the second segment. As a result, the polymer along the first segment and the third segment would have a greater percent crystallinity than the polymer along the second

segment. Therefore, the diffusion rates of the active agent from the polymer matrix along the first segment and the third segment would be less than the diffusion rate along the second segment.

[0074] In another embodiment, by limiting the time that the coating is exposed to thermal radiation so that the percent crystallinity is not maximized throughout the entire thickness of the coating, the shallower regions of the coating will have a higher percent crystallinity than the deeper regions. In a particular example, if the coating has four regions with the fourth region as the deepest, by limiting the thermal treatment, the first or shallowest region would have a higher percent crystallinity than the fourth or deepest region. One of ordinary skill in the art will understand that the duration and temperature of the exposure will depend on the desired diffusion rate of the polymer, and the inherent characteristics of the polymers used in the coating.

Sterilization of the Implantable Device

[0075] After the implantable device has been coated according to the various embodiments of the present invention, the implantable device can be sterilized by various methods. According to conventional thought, a coating containing 40-O-(2-hydroxy)ethyl-rapamycin cannot be sterilized with many techniques because the 40-O-(2-hydroxy)ethyl-rapamycin is degraded by the processes. For example, it was thought that a polymer coating containing 40-O-(2-hydroxy)ethyl-rapamycin could not be sterilized with an e-beam procedure because the free radicals produced during the process would degrade the 40-O-(2-hydroxy)ethyl-rapamycin. Similarly, it has been thought that exposing a coating with 40-O-(2-hydroxy)ethyl-rapamycin to ethylene oxide or peroxide gas would also degrade the 40-O-(2-hydroxy)ethyl-rapamycin. However, it has unexpectedly been found that the coatings of the present invention protect the 40-O-(2-hydroxy)ethyl-rapamycin during sterilization procedures (e.g., using an e-beam or ethylene oxide process). In fact, subsequent to sterilization, the peak purity of the 40-O-(2-hydroxy)ethyl-rapamycin has been greater than 90% when included in the coatings of the present invention.

[0076] In an embodiment of the present invention, the particular procedure used to sterilize the coating can also be used to expose the coating to a temperature that is effective to decrease the diffusion rate of the 40-O-(2-hydroxy)ethyl-rapamycin from the polymer matrix. In particular, during the sterilization procedure (e.g., the ethylene oxide procedure) the coating can be exposed to a sufficient temperature effective to decrease the release rate of the 40-O-(2-hydroxy)ethyl-rapamycin, or analog or derivative thereof, by about 50% as compared to a control group.

Examples of the Device

[0077] The device or prosthesis coated in accordance with embodiments of the present invention may be any suitable medical substrate that can be implanted in a human or veterinary patient. Examples of such implantable devices include self-expandable stents, balloon-expandable stents, stent-grafts, grafts (e.g., aortic grafts), artificial heart valves, cerebrospinal fluid shunts, pacemaker electrodes, and endocardial leads (e.g., FINELINE and ENDOTAK, available from Guidant Corporation, Santa Clara, Calif.). The underlying structure of the device can be of virtually any design.

The device can be made of a metallic material or an alloy such as, but not limited to, cobalt chromium alloy (ELGILOY), stainless steel (316L), high nitrogen stainless steel, e.g., BIODUR 108, cobalt chrome alloy L-605, "MP35N," "MP20N," ELASTINITE (Nitinol), tantalum, nickel-titanium alloy, platinum-iridium alloy, gold, magnesium, or combinations thereof. "MP35N" and "MP20N" are trade names for alloys of cobalt, nickel, chromium and molybdenum available from Standard Press Steel Co., Jenkintown, Pa. "MP35N" consists of 35% cobalt, 35% nickel, 20% chromium, and 10% molybdenum. "MP20N" consists of 50% cobalt, 20% nickel, 20% chromium, and 10% molybdenum. Devices made from bioabsorbable or biostable polymers could also be used with the embodiments of the present invention.

[0078] The embodiments of the present invention may be particularly useful for the coatings of small vessel stents. Small vessel stents can be generally categorized as having inner diameters of less than 2.5 mm in an expanded state. Because of their small size, small vessel stents offer unique challenges for drug delivery. In particular, as compared to conventionally sized stents, small vessel stents have a greater surface:volume ratio. Therefore, when a small vessel stent is inserted into a biological lumen, the vessel tissue surrounding a small vessel stent is exposed to a greater concentration of polymer and active agent.

[0079] The various embodiments of the present invention can be used to address some of the challenges offered by the use of small vessel stents. For example, it is thought that it is especially important that small vessel stents have lower amounts of polymer in their coatings, as compared to larger sized stents, in order to reduce the risk of an inflammatory response by the vessel tissue. However, it may also be important to have a barrier layer on the stent coating in order to have a low release rate of the active agents, such as 40-O-(2-hydroxy)ethyl-rapamycin. With the inclusion of the barrier layer, the amount of polymer on the coating may be sufficient to cause an unwanted inflammatory response. In order to address these countervailing concerns, one approach would be to provide a thinner barrier layer on the polymer matrix as compared to larger sized stents, and then heat treat the barrier layer to increase the crystallinity of the barrier layer polymer, thereby decreasing the release rate of the active agent from the reservoir region. In an alternative embodiment, the polymer used for the barrier layer can initially have a very high percent crystallinity. In yet another embodiment, the reservoir layer can be heat treated to reduce the release rate of active agent from the reservoir region without the use of a barrier layer.

[0080] In another particular example, it is thought that it is especially important for small vessel stems to have a biocompatible coating. One approach to address this need is to provide a finishing layer on the stent that contains a highly biocompatible polymer such as polyethylene glycol, or biocompatible agents such as heparin. For example, a finishing layer can be applied over a barrier layer so that the coating offers a usefully low release rate of an active agent and also provides a highly biocompatible coating.

Coating

[0081] Some of the various embodiments of the present invention are illustrated by FIGS. 1A, 1B, and 1C. The

Figures have not been drawn to scale, and the thickness of the various layers have been over or under emphasized for illustrative purposes.

[0082] Referring to FIG. 1A, a body of a medical substrate **20**, such as a stent, is illustrated having a surface **22**. Medical substrate **20** includes cavities or micropores **24** formed in the body for releasably containing an active ingredient, as illustrated by dotted region **26**. A barrier layer or rate-reducing membrane **28** is disposed on surface **22** of medical substrate **20**, covering cavities **24**. Barrier layer **28** functions to reduce the rate of release of an active agent (e.g., 40-O-(2-hydroxy)ethyl-rapamycin) from medical substrate **20**.

[0083] Referring to FIG. 1B, medical substrate **20** is illustrated having a primer layer **30** formed on surface **22**. An active agent-containing or reservoir coating **32** is deposited on primer layer **30**. Primer layer **30** serves as an intermediary layer for increasing the adhesion between reservoir coating **32** and surface **22**. Increasing the amount of active ingredient admixed within the polymer diminishes the adhesiveness of reservoir layer **32** to surface **22**. Accordingly, using an active agent-free polymer as an intermediary primer layer **30** allows for a higher active ingredient content for reservoir layer **32**. Barrier layer **28** is formed over at least a selected portion of reservoir layer **32**. One of ordinary skill in the art can appreciate that barrier layer **28** can be deposited only on selected areas of reservoir layer **32** so as to provide a variety of selected release parameters. Such selected patterns may become particularly useful if a combination of active agents are used, each of which requires a different release parameter.

[0084] FIG. 1C illustrates medical substrate **20** having a first reservoir layer **32A** disposed on a selected portion of surface **22** of medical substrate **20**. First reservoir layer **32A** contains a first active agent, e.g., 40-O-(2-hydroxy)ethyl-rapamycin. A second reservoir layer **32B** can also be disposed on surface **22**. Second reservoir layer **32B** contains a second active ingredient, e.g., taxol. First and second reservoir layers **32A** and **32B** are covered by first and second barrier layers **28A** and **28B**, respectively. In accordance with one embodiment, the polymeric material in barrier layer **28B** has been exposed to thermal treatment, whereas the polymeric material in barrier layer **28A** has not. As a result, the polymeric material in barrier **28B** has a higher percent crystallinity than the polymeric material in barrier layer **28A**. Accordingly, by producing a coating such as the one shown in FIG. 1C, a wide array of release parameters can be obtained for any selected combination of active agents.

[0085] Barrier layer **28** can have any suitable thickness, as the thickness of barrier layer **28** is dependent on parameters such as, but not limited to, the desired rate of release and the procedure for which the stent will be used. For example, barrier layer **28** can have a thickness of about 0.1 to about 10 microns, more narrowly from about 0.25 to about 5 microns.

[0086] By way of example, and not limitation, the impregnated reservoir layer **32** can have a thickness of about 0.5 microns to about 1.5 microns. The particular thickness of reservoir layer **32** is based on the type of procedure for which medical substrate **20** is employed and the amount of the active agent to be delivered. The amount of the active agent to be included on the prosthesis can be further increased by applying a plurality of reservoir layers **32** on top of one another. The optional primer layer **30** can have

any suitable thickness, examples of which can be in range of about 0.1 to about 10 microns, more narrowly about 0.1 to about 2 microns.

Method of Use

[0087] In accordance with the above-described method, the active agent can be applied to a device, e.g., a stent, retained on the device during delivery and released at a desired control rate and for a predetermined duration of time at the site of implantation. A stent having the above-described coating layers is useful for a variety of medical procedures, including, by way of example, treatment of obstructions caused by tumors in bile ducts, esophagus, trachea/bronchi and other biological passageways. A stent having the above-described coating layers is particularly useful for treating occluded regions of blood vessels caused by abnormal or inappropriate migration and proliferation of smooth muscle cells, thrombosis, and restenosis. Stents may be placed in a wide array of blood vessels, both arteries and veins. Representative examples of sites include the iliac, renal, and coronary arteries.

[0088] Briefly, an angiogram is first performed to determine the appropriate positioning for stent therapy. Angiography is typically accomplished by injecting a radiopaque contrasting agent through a catheter inserted into an artery or vein as an x-ray is taken. A guidewire is then advanced through the lesion or proposed site of treatment. Over the guidewire is passed a delivery catheter, which allows a stent in its collapsed configuration to be inserted into the passageway. The delivery catheter is inserted either percutaneously, or by surgery, into the femoral artery, brachial artery, femoral vein, or brachial vein, and advanced into the appropriate blood vessel by steering the catheter through the vascular system under fluoroscopic guidance. A stent having the above-described coating layers may then be expanded at the desired area of treatment. A post insertion angiogram may also be utilized to confirm appropriate positioning.

EXAMPLES

[0089] The embodiments of the present invention will be illustrated by the following set forth examples.

Example 1

[0090] 35 13 mm PENTA stents (available from Guidant Corporation) were coated by spraying a 2% (w/w) solution of poly(ethylene-co-vinyl alcohol) (44 mole % ethylene) ("EVAL") in 98% (w/w) dimethylacetamide. The solvent was removed by baking at 140° C. for 2 hours. A solution of 1.9% (w/w) EVAL and 0.7% (w/w) 40-O-(2-hydroxy)ethyl-rapamycin in a mixture of 68.2% (w/w) dimethylacetamide and 29.2% (w/w) ethanol was spray coated onto the stents to a thickness with a target of 175 µg of 40-O-(2-hydroxy)ethyl-rapamycin on each stent. The stents were then baked at 50° C. for 2 hours. A barrier layer was formed by spraying the stents with a 4% (w/w) solution of EVAL in a mixture of 76% (w/w) dimethylacetamide and 20% (w/w) pentane. Another 2 hour bake at 50° C. was performed to remove the solvent.

[0091] A select number of stents were analyzed to compare the target coating formulation with the final coating formulation. The results are as follows: For the primer layer, there was a target dry weight of 40 µg of polymer, and a measured average dry weight of 43±3 µg of polymer. For the

reservoir layer, the target drug:polymer ratio was 1:2.857, the target dry weight for the entire reservoir coating was 675 μg and the average actual dry weight was 683 ± 19 μg . Also for the reservoir layer, the average total drug content of the stent coatings was determined by the process described in Example 2. The average drug content was 133 μg or 152 $\mu\text{g}/\text{cm}^2$. For the barrier layer, the target dry weight of polymer was 300 μg and the measured average dry weight was 320 ± 13 μg .

Example 2

[0092] A drug-coated stent was placed in a volumetric flask. An appropriate amount of the extraction solvent acetonitrile with 0.02% BHT as protectant was added (e.g., in a 10 ml volumetric flask, with about 9 ml solvent added). The flask was sonicated for a sufficient time to extract all of the drug from the reservoir region. Then, the solution in the flask was filled to mark with the solvent solution. The drug solution was analyzed by HPLC. The HPLC system consisted of a Waters 2690 system with an analytical pump, a column compartment (set at 40° C.), an auto-sampler, and a 996 PDA detector. The column was an YMC Pro C18 (150 mm \times 4.6 I.D., 3 μm particle size), maintained at a temperature of 40° C. The mobile phase consisted of 75% acetonitrile and 25% 20 mMolar ammonium acetate. The flow rate was set on 1 ml/min. The HPLC release rate results were quantified by comparing the results with a reference standard. The total drug content of the stent was then calculated.

Example 3

[0093] 34 13 mm PENTA stents were coated by spraying a 2% (w/w) solution of EVAL and 98% (w/w) dimethylacetamide. The solvent was removed by baking at 140° C. for 2 hours. A solution of 1.9% (w/w) EVAL and 1.1% (w/w) 40-O-(2-hydroxy)ethyl-rapamycin in a mixture of 67.9% (w/w) dimethylacetamide and 29.1% (w/w) ethanol was spray coated onto the stents to a thickness with a target of 275 μg of 40-O-(2-hydroxy)ethyl-rapamycin on each stent. The stents were then baked at 50° C. for 2 hours. A barrier layer was formed by spraying the stents with a 4% (w/w) solution of EVAL in a mixture of 76 % (w/w) dimethylacetamide and 20% (w/w) pentane. Another 2 hour bake at 50° C. was performed to remove the solvent.

[0094] A select number of stents were analyzed to compare the target coating formulation with the final coating formulation. The results are as follows: For the primer layer, there was a target dry weight of 40 μg of polymer, and a measured average dry weight of 43 ± 3 μg of polymer. For the reservoir layer, the target drug:polymer ratio was 1:1.75, the target dry weight for the entire reservoir coating was 757 μg and the average actual dry weight was 752 ± 23 μg . Also for the reservoir layer, the average total drug content of the stent coatings was determined by the process described in Example 2. The average drug content was 205 μg or 235 $\mu\text{g}/\text{cm}^2$. For the barrier layer, the target dry weight of polymer was 200 μg and the measured average dry weight was 186 ± 13 μg .

Example 4

[0095] 24 13 mm PENTA stents were coated by spraying a 2% (w/w) solution of EVAL and 98% (w/w) dimethylacetamide. The solvent was removed by baking at 140° C. for 2 hours. A solution of 1.9% (w/w) EVAL and 1.2% (w/w)

40-O-(2-hydroxy)ethyl-rapamycin in a mixture of 67.8% (w/w) dimethylacetamide and 29.1% (w/w) ethanol was spray coated onto the stents to a thickness with a target of 325 μg of 40-O-(2-hydroxy)ethyl-rapamycin on each stent. The stents were then baked at 50° C. for 2 hours. A barrier layer was formed by spraying the stents with a 4% (w/w) solution of EVAL in a mixture of 76 % (w/w) dimethylacetamide and 20% (w/w) pentane. Another 2 hour bake at 50° C. was performed to remove the solvent.

[0096] A select number of stents were analyzed to compare the target coating formulation with the final coating formulation. The results are as follows: For the primer layer, there was a target dry weight of 40 μg of polymer, and a measured average dry weight of 41 ± 2 μg of polymer. For the reservoir layer, the target drug:polymer ratio was 1:1.6, the target dry weight for the entire reservoir coating was 845 μg and the average actual dry weight was 861 ± 16 μg . Also for the reservoir layer, the average total drug content of the stent coatings was determined by the process described in Example 2. The average drug content was 282 μg or 323 $\mu\text{g}/\text{cm}^2$. For the barrier layer, the target dry weight of polymer was 125 μg and the measured average dry weight was 131 ± 9 μg .

Example 5

[0097] This Example 5 is referred to as the "Release Rate Profile Procedure." A drug-coated stent was placed on a stent holder of a Vankel Bio-Dis release rate tester (Vankel, Inc., Cary, N.C.). The stent was dipped into an artificial medium which stabilizes the 40-O-(2-hydroxy)ethyl-rapamycin in the testing solution, including a phosphate buffer saline solution (10 mM, pH 7.4) with 1% TRITON X-100 (Sigma Corporation), for a designated amount of time (e.g., 3 hours). Then the solution was analyzed for the amount of drug released from the stent coating using an HPLC process. The HPLC system consisted of a Waters 2690 system with an analytical pump, a column compartment (set at 40° C.), an auto-sampler, and a 996 PDA detector. The column was an YMC Pro C18 (150 mm \times 4.6 I.D., 3 μm particle size), maintained at a temperature of 40° C. The mobile phase consisted of 75% acetonitrile and 25% 20 mMolar ammonium acetate. The flow rate was set on 1 ml/min. After the drug solution was analyzed by HPLC the results were quantified by comparing the release rate results with a reference standard.

[0098] If the experimental protocol required that the stent coating be subjected to experimental conditions for an additional time, the stent was then dipped in a fresh medium solution for the necessary amount of time (e.g., another 3 hours) and the drug released in the solution was analyzed again according to the HPLC procedure described above. The procedure was repeated according to the number of data points required. The release rate profile could then be generated by plotting cumulative drug released in the medium vs. time.

Example 6

[0099] The release rate of 40-O-(2-hydroxy)ethyl-rapamycin from the stents with coatings produced by the processes under Examples 1, 3 and 4 were tested using the in vitro HPLC process as described in Example 5. The solution for each stent underwent two HPLC runs, and the results were averaged.

[0100] The following Table 2 summarizes the results of the release rate procedure for two stents from Example 1:

TABLE 2

Time (hrs)	3	6	9	12	23	32	48
Cumulative Release from Stent 1 (µg)	3.72	5.62	7.12	8.43	12.28	15.31	20.28
Cumulative Release from Stent 2 (µg)	4.18	6.53	8.54	10.29	15.64	19.66	26.3

[0101] The following Table 3 summarizes the results of the release rate procedure for two stents from Example 3:

TABLE 3

Time (hrs)	3	6	9	12	23	32	48
Cumulative Release from Stent 1 (µg)	29.73	45.35	57.79	68.19	95.2	110.85	130.75
Cumulative Release from Stent 2 (µg)	26.36	41.2	53.5	63.99	93.93	112.31	135.7

[0102] The following Table 4 summarizes the results of the release rate procedure for two stents from Example 4:

TABLE 4

Time (hrs)	3	6	9	12	23	32	48
Cumulative Release from Stent 1 (µg)	46.24	67.4	82.79	94.92	124.72	141.96	165.12
Cumulative Release from Stent 2 (µg)	44.66	66.74	82.26	94.49	123.92	140.07	159.65

[0103] A comparison of the release rates for tita stents from Examples 1, 3 and 4 is graphically shown in FIG. 2.

Example 7

[0104] The following Example 7 is referred to as the “3 day In Vivo Release Rate Procedure” or the “9 day In Vivo Release Rate Procedure,” depending on the number of days the stents are inserted into the experimental animal. The following are the materials used for this Example:

- [0105]** 1. Experimental animal: One 30-45 kg Yorkshire cross pig;
- [0106]** 2. BMW™ wires 0.014", 190 cm;
- [0107]** 3. Guide wire 0.035", 190 cm;
- [0108]** 4. Viking guide catheters, 7F;
- [0109]** 5. Introducer sheaths (8-10F);
- [0110]** 6. ACS 20/20 Indeflator™ Inflation Device;
- [0111]** 7. Saline; solution with heparin;
- [0112]** 8. Nitroglycerin, Lidocaine, other inotropic/chronotropic drugs;
- [0113]** 9. Standard surgical equipment, anesthetic, and medications as necessary;

- [0114]** 10. Respiratory and hemodynamic monitoring systems;
 - [0115]** 11. Positive pressure ventilator and associated breathing circuits;
 - [0116]** 12. ACT machine and accessories;
 - [0117]** 13. PTCA accessories;
 - [0118]** 14. Ambulatory defibrillator;
 - [0119]** 15. Fluoroscopy equipment; and
 - [0120]** 16. Non-ionic contrast agent;
- [0121]** The following was the procedure used for this Example:

A. Animal Preparation.

- [0122]** 1. Administer Aspirin (325 mg PO) once daily starting one day prior to stent implantation.
- [0123]** 2. Sedate the pig.
- [0124]** 3. Intubate the trachea via an oral approach.
- [0125]** 4. Deliver isoflurane (up to about 5%) to achieve and maintain an adequate plane of anesthesia.
- [0126]** 5. Shave the sheath introduction area free of hair and scrub the surgical site with surgical soap and/or antiseptic solution.
- [0127]** 6. Place a 7F introducer sheath into the right or left femoral artery.
- [0128]** 7. Obtain an arterial blood sample for a baseline ACT.
- [0129]** 8. Administer heparin 200 units/kg IV (not to exceed 100,000 units) and obtain a blood sample for measurement of ACT 5-10 minutes later.
- [0130]** 9. Repeat heparin as needed to maintain ACT ≥ 300 seconds.
- [0131]** 10. Measure and record arterial blood pressure, heart rate and electrocardiogram (ECG).

B. Angiography for Vessel Selection.

- [0132]** 1. Advance the guiding catheter over the guide-wire into the aortic arch and cannulate the desired vessel.
- [0133]** 2. Administer nitroglycerin (200 µg) intra-luminally prior to baseline angiography.
- [0134]** 3. Perform baseline angiogram and record images on cine.
- [0135]** 4. With the diameter of the guiding catheter as a reference, select vasculature that will allow a target stent to artery ratio of about 1.1:1.0.

C. Stent Preparation and Deployment.

- [0136]** 1. Perform online QCA and measure baseline proximal, target, and distal reference sites.
- [0137]** 2. Administer nitroglycerin (200 µg) intra-luminally prior to stent deployment, then as needed to control coronary artery vasospasm.
- [0138]** 3. Inspect the stent delivery system. Ensure that the stent is correctly positioned on the balloon. Inspect the stent for any abnormalities.
- [0139]** 4. Flush guidewire lumen with heparinized saline until fluid exits the guidewire notch.
- [0140]** 5. Prepare Indeflator/syringe with diluted (approximately 50:50) contrast medium.
- [0141]** 6. Attach syringe to test catheter inflation port; use standard techniques to fill the inflation lumen with diluted contrast.

- [0142] 7. Purge syringe and test catheter inflation lumen of all air.
- [0143] 8. Purge Deflator of all air and attach to test catheter inflation port.
- [0144] 9. Position an appropriate guidewire in the distal bed of the target artery.
- [0145] 10. Insert the stent delivery system through the guiding catheter over the guidewire.
- [0146] 11. Advance the stent delivery system to the pre-selected arterial deployment site.
- [0147] 12. Position balloon for inflation.
- [0148] 13. Refer to IFU for inflation strategy. If no IFU available, inflate the balloon at a slow steady rate to a pressure that expands the stent to the desired diameter. Hold at this pressure for 30 seconds.
- [0149] 14. Record inflated balloon by pulling image on cine. Perform on-line QCA and measure the inflated balloon diameter.
- [0150] 15. Deflate balloon by pulling negative pressure. While withdrawing the system, observe tactually and fluoroscopically. Record any resistance.
- [0151] 16. Administer nitroglycerin (200 µg) intraluminally.
- [0152] 17. Assess patency, deployment and placement of stent via coronary angiography.
- [0153] 18. Assess TIMI angiographic low grade.
- [0154] 19. Record on cine and video.
- [0155] 20. Measure post-proximal, target, and distal MLD with QCA.
- [0156] 21. Repeat Section C with remaining stent delivery system.
- [0157] 22. Measure and record heart rate, arterial blood pressure and electrocardiogram (ECG).

D. Stent Procedure End.

- [0158] 1. Remove the guidewire, guiding catheter and introducer sheath.
- [0159] 2. Remove introducer sheath from the femoral artery.
- [0160] 3. Apply pressure to the femoral artery at the side of sheath entry.
- [0161] 4. Allow the animal to recover from anesthesia in an individual cage.
- [0162] 5. Give Buprenorphine (0.05 mg/kg) PRN as needed for pain.
- [0163] 6. Administer Ticiopidine (250 mg PO) and aspirin (325 mg PO) once daily until date of follow-up angiography.

E. Study End.

- [0164] 1. Euthanize the pig with an overdose of barbiturates and/or potassium chloride.
- [0165] 2. Excise the heart without flushing the vessels.
- [0166] 3. Harvest all stented arteries.
- [0167] 4. Remove the stent from all treated arteries and place them in dark colored amber vials for subsequent drug concentration analysis.
- [0168] 5. Snap freeze the arterial tissue in liquid nitrogen and store at -70° C. until subsequent analysis of tissue for drug concentrations as determined by HPLC.
- [0169] The stents harvested from the experimental animals were tested using an HPLC procedure to determine how much drug remained on the stents. A drug-coated stent

removed from the experimental animal was placed in a volumetric flask. An appropriate amount of the extraction solvent acetonitrile with 0.02% BHT as protectant was added (e.g., in a 10 ml volumetric flask, with about 9 ml solvent added). The flask was sonicated for a sufficient time to extract all of the drug from the reservoir region. Then, the solution in the flask, was filled to mark with the solvent solution. The HPLC system consisted of a Waters 2690 system with an analytical pump, a column compartment (set at 40° C.), an auto-sampler, and a 996 PDA detector. The column was an YMC Pro C18 (150 mm×4.6 I.D., 3 µm particle size), maintained at a temperature of 40° C. The mobile phase consisted of 75% acetonitrile and 25% 20 mMolar ammonium acetate. The flow rate was set on 1 ml/min. The HPLC release rate results were quantified by comparing the results with a reference standard. The total drug released in vivo was the difference between the average drug loaded on the stents and the amount of drug remaining on the stents after the stent implantation into the experimental animal.

Example 8

[0170] The release rate of 40-O-(2-hydroxy)ethyl-rapamycin from the stents with coatings produced by the process under Example 1 were tested using a 3 day in vivo process as described in Example 7. In particular, stents from Example 1 were implanted into experimental animals and then the stents were tested by HPLC to determine how much 40-O-(2-hydroxy)ethyl-rapamycin diffused from the stent coating into the blood vessel. According to the HPLC analysis, 21.8 µg of the 40-O-(2-hydroxy)ethyl-rapamycin was released from the coating in 3 days, or 16.4% of the total drug content of the coating.

Example 9

[0171] The release rate of 40-O-(2-hydroxy)ethyl-rapamycin from the stents with coatings produced by the process under Example 3 were tested using a 3 day in vivo process as described in Example 7. In particular, stents from Example 3 were implanted into experimental animals and then the stents were tested by HPLC to determine how much 40-O-(2-hydroxy)ethyl-rapamycin diffused from the stent coating into the blood vessel. According to the HPLC analysis, 7.8 µg of the 40-O-(2-hydroxy)ethyl-rapamycin was released from the coating in 3 days, or 3.8% of the total drug content of the coating.

Example 10

[0172] The release rate of 40-O-(2-hydroxy)ethyl-rapamycin from the stents with coatings produced by the process under Example 4 were tested using a 3 day in vivo process as described in Example 7. In particular, stents from Example 4 were implanted into experimental animals and then the stents were tested by HPLC to determine how much 40-O-(2-hydroxy)ethyl-rapamycin diffused from the stent coating into the blood vessel. According to the HPLC analysis, 50.8 µg of the 40-O-(2-hydroxy)ethyl-rapamycin was released from the coating in 3 days, or 18% of the total drug content of the coating.

Example 11

[0173] The release rate of 40-O-(2-hydroxy)ethyl-rapamycin from the stents with coatings produced by the

process under Example 3 were tested using a 9 day in vivo process as described in Example 7. In particular, stents from Example 3 were implanted into experimental animals and then the stents were tested by HPLC to determine how much 40-O-(2-hydroxy)ethyl-rapamycin diffused from the stent coating into the blood vessel. According to the HPLC analysis, 29.7%, of the 40-O-(2-hydroxy)ethyl-rapamycin was released from the coating in 9 days.

Example 12

[0174] The release rate of 40-O-(2-hydroxy)ethyl-rapamycin from the stents with coatings produced by the process under Example 4 were tested using a 9 day in vivo process as described in Example 7. In particular, stents from Example 4 were implanted into experimental animals and then the stents were tested by HPLC to determine how much 40-O-(2-hydroxy)ethyl-rapamycin diffused from the stent coating into the blood vessel. According to the HPLC analysis, 39.4% of the 40-O-(2-hydroxy)ethyl-rapamycin was released from the coating in 9 days.

Example 13

[0175] A 13 mm PIXEL stent (available from Guidant Corporation) was coated. The stent had a yellowish-gold coating that included ethylene vinyl alcohol copolymer and actinomycin D. The ends of the stent were heated with a cauterizer tip for fifteen (15) seconds at a current setting of 2.2 Amps, which corresponded to a temperature of about 106° C. at a distance of about 0.006 inches from the stent.

[0176] After the stent was exposed to heat from the cauterizer tip, the stent was submerged in a 50% (w/w) methanol:water bath. After twenty-four (24) hours, the stent was observed to have drug present at the stent end rings as indicated by a yellowish hue. The middle section of the stent, however, was clear, indicating that the drug had been released through the polymer. This process was repeated on 40 stents yielding similar results for all the stents.

Example 14

[0177] 13 mm PIXEL stents were coated. The stents had yellowish-gold coatings that included ethylene vinyl alcohol copolymer and actinomycin D. The stents were separated into three experimental groups, and the ends of the stents were heated with a cauterizer tip according to the parameters shown in Table 5 for each group. After the stents were exposed to heat from the cauterizer tip, the stent was submerged in a 50% (w/w) methanol:water bath. After twenty-four (24) hours, the stents were observed as summarized in Table 5.

TABLE 5

Experimental Group	Current (Amps)	Exposure Time (Seconds)	Observation
1	2.0	10	Least gold coloration in the end sections compared to the stents from Experimental Groups 2 and 3, indicating the least amount of drug remaining in the stent coating.
2	2.2	8	Moderate gold coloration in the end sections.

TABLE 5-continued

Experimental Group	Current (Amps)	Exposure Time (Seconds)	Observation
3	2.4	5	Most gold coloration in the end sections compared to the stents from Experimental Groups 1 and 2 indicating the most amount of drug remaining in the stent coating.

[0178] It was observed that the coating in the middle section of the stents, which did not have significant exposure to heat from the cauterizer tip, was clear. This indicates that the drug had been eluted from the stents. On the other hand, the end rings of the stents which had been exposed to heat from the cauterizer tip still appeared gold in color, indicating the presence of drug in the stent coating. The results above indicate that varying the amount of time and heat exposure can modify the elution rate of drug from the stent.

Example 15

[0179] 8 mm PIXEL stents were coated by spraying a 2% (w/w) solution of EVAL and 98% (w/w) dimethylacetamide. The solvent was removed by baking at 140° C. for 2 hours. A solution of EVAL and 40-O-(2-hydroxy)ethyl-rapamycin in a mixture of 70% (w/w) dimethylacetamide and 30% (w/w) ethanol was spray coated onto the stents. The stents were then baked at 50° C. for 2 hours. A barrier layer was formed by spraying the stents with a solution of EVAL in a mixture of 80% (w/w) dimethylacetamide and 20% (w/w) pentane. Another 2 hour bake at 50° C. was performed to remove the solvent.

[0180] A select number of stents were analyzed to compare the target coating formulation with the final coating formulation. The results are as follows: For the primer layer, there was a target dry weight of 26 µg of polymer, and a measured average dry weight of 28±3 µg of polymer. For the reservoir layer, the target drug:polymer ratio was 1:1.25, and the measured average drug content was 128 µg. For the barrier layer, the measured average dry weight was 84 µg.

Example 16

[0181] 8 mm PIXEL stents were coated by spraying a 2% (w/w) solution of EVAL and 98% (w/w) dimethylacetamide. The solvent was removed by baking at 140° C. for 2 hours. A solution of EVAL and 40-O-(2-hydroxy)ethyl-rapamycin in a mixture of 70% (w/w) dimethylacetamide and 30% (w/w) ethanol was spray coated onto the stents. The stents were then baked at 50° C. for 2 hours. A barrier layer was formed by spraying the stents with a solution of EVAL in a mixture of 80% (w/w) dimethylacetamide and 20% (w/w) pentane. Another 2 hour bake at 50° C. was performed to remove the solvent.

[0182] A select number of stents were analyzed to compare the target coating formulation with the final coating formulation. The results are as follows: For the primer layer, there was a target dry weight of 26 µg of polymer, and a measured average dry weight of 28±2 µg of polymer. For the reservoir layer, the target drug:polymer ratio was 1:1.5, and the measured average drug content was 130 µg. For the barrier layer, the measured average dry weight was 81 µg.

[0183] After the solvent had been substantially removed and the coatings had been formed, a select number of stents were then heat treated by exposing the stents to a heat of 80° C. for 2 hours.

Example 17

[0184] The release rate of 40-O-(2-hydroxy)ethyl-rapamycin from the stents with coatings produced by the processes under Examples 15 and 16 were tested using the process described in Example 5. The following Table 6 summarizes the results of the release rate procedure for three stents from Example 15:

TABLE 6

Time (hrs)	3	6	9	12	24	32	48
Cumulative Release from Stent 1 (µg)	15.44	24.63	32.20	38.43	56.04	64.81	77.36
Cumulative Release from Stent 2 (µg)	12.70	21.29	28.57	34.55	51.19	59.27	71.15
Cumulative Release from Stent 3 (µg)	13.00	21.92	29.31	35.40	52.55	60.48	72.05

[0185] The following Table 7 summarizes the results of the release rate procedure for three stents from Example 16:

TABLE 7

Time (hrs)	3	6	9	12	24	32	48
Cumulative Release from Stent 1 (µg)	5.52	9.37	12.73	15.71	24.33	29.20	38.02
Cumulative Release from Stent 2 (µg)	6.73	10.86	14.39	17.41	25.99	30.29	38.00
Cumulative Release from Stent 3 (µg)	5.76	9.14	12.02	14.50	21.21	24.61	31.23

[0186] A comparison of the release rates for the stents from Examples 15-16 is graphically shown in FIG. 3. The results unexpectedly show that the stent coatings that were exposed to thermal treatment in Example 16 have a significantly lower release rate than the stent coatings of Example 15.

Example 18

[0187] This Example 18 is referred to as the "Porcine Serum Release Rate Procedure." A drug-coated stent was placed on a stent holder of a Vankel Bio-Dis release rate tester. The stent was dipped into porcine serum, with 0.1% sodium azide added, for 24 hrs. The stent was removed from the porcine serum and the drug solution analyzed by an HPLC procedure to determine how much drug was released into the porcine serum. The HPLC system consisted of a Waters 2690 system with an analytical pump, a column compartment (set at 40° C.), an auto-sampler, and a 996 PDA detector. The column was an YMC Pro C18 (150

mm×4.6 I.D., 3 µm particle size), maintained at a temperature of 40° C. The mobile phase consisted of 75% acetonitrile and 25% 20 mMolar ammonium acetate. The flow rate was set on 1 ml/min. The HPLC release rate results were quantified by comparing the results with a reference standard.

Example 19

[0188] 13 mm PENTA stents were coated by spraying a 2% (w/w) solution of EVAL and 98% (w/w) dimethylacetamide. The solvent was removed by baking at 140° C. for 2 hours. A solution of EVAL and 40-O-(2-hydroxy)ethyl-rapamycin in a mixture of 70% (w/w) dimethylacetamide and 30% (w/w) ethanol was spray coated onto the stents. The stents were then baked at 50° C. for 2 hours. A barrier layer was formed by spraying the stents with a solution of EVAL in a mixture of 80% (w/w) dimethylacetamide and 20% (w/w) pentane. Another 2 hour bake at 50° C. was performed to remove the solvent.

[0189] A select number of stents were analyzed to quantify the coating components. For the primer layer, there was a target dry weight of 40 µg of polymer, and a measured average dry weight of 45±1 µg of polymer. For the reservoir layer, the drug:polymer ratio was 1:1, and the measured average drug content was 151 µg as determined by Example 2. For the barrier layer, the measured average dry weight was 234 µg.

[0190] After the coatings were formed on the stents, a select number of stents were tested for the drug release rate from the coatings according to the procedure described in Example 18. It was determined that the average drug released in 24 hours was 32.6 µg, or 21.6% of the total.

Example 20

[0191] 13 mm PENTA stents were coated by spraying a 2% (w/w) solution of EVAL and 98% (w/w) dimethylacetamide. The solvent was removed by baking at 140° C. for 2 hours. A solution of EVAL and 40-O-(2-hydroxy)ethyl-rapamycin in a mixture of 70% (w/w) dimethylacetamide and 30% (w/w) ethanol was spray coated onto the stents. The stents were then baked at 50° C. for 2 hours. A barrier layer was formed by spraying the stents with a solution of EVAL in a mixture of 80% (w/w) dimethylacetamide and 20% (w/w) pentane. Another 2 hour bake at 50° C. was performed to remove the solvent.

[0192] A select number of stents were analyzed to quantify the coating components. For the primer layer, there was a target dry weight of 40 µg of polymer, and a measured average dry weight of 44±3 µg of polymer. For the reservoir layer, the drug:polymer ratio was 1:1.8, and the measured average drug content was 97 µg as determined by Example 2. For the barrier layer, the measured average dry weight was 184 µg.

[0193] After the coatings were formed on the stents, a select number of stents were tested for the drug release rate from the coatings according to the procedure described in Example 18. It was determined that the average drug released in 24 hours was 24.1 µg, or 24.8% of the total.

Example 21

[0194] 13 mm PENTA stents were coated by spraying a 2% (w/w) solution of EVAL and 98% (w/w) dimethylacetamide. The solvent was removed by baking at 140° C. for 2

hours. A solution of EVAL and 40-O-(2-hydroxy)ethyl-rapamycin in a mixture of 70% (w/w) dimethylacetamide and 30% (w/w) ethanol was spray coated onto the stents. The stents were then baked at 50° C. for 2 hours. A barrier layer was formed by spraying the stents with a solution of EVAL in a mixture of 80% (w/w) dimethylacetamide and 20% (w/w) pentane. Another 2 hour bake at 50° C. was performed to remove the solvent.

[0195] A select number of stents were analyzed to quantify the coating components. For the primer layer, there was a target dry weight of 40 µg of polymer, and a measured average dry weight of 41±1 µg of polymer. For the reservoir layer, the drug:polymer ratio was 1:1.8, and the measured average drug content was 227 µg as determined by Example 2. For the barrier layer, the measured average dry weight was 181 µg.

[0196] After the coatings were formed on the stents, a select number of stents were tested for the drug release rate from the coatings according to the procedure described in Example 18. It was determined that the average drug released in 24 hours was 27.5 µg, or 12.1% of the total.

Example 22

[0197] 13 mm PENTA stents were coated by spraying a 2% (w/w) solution of EVAL and 98% (w/w) dimethylacetamide. The solvent was removed by baking at 140° C. for 2 hours. A solution of EVAL and 40-O-(2-hydroxy)ethyl-rapamycin in a mixture of 70% (w/w) dimethylacetamide and 30% (w/w) ethanol was spray coated onto the stents. The stents were then baked at 50° C. for 2 hours. No barrier layer was applied for this Example.

[0198] A select number of stents were analyzed to quantify the coating components. For the primer layer, there was a target dry weight of 40 µg of polymer, and a measured average dry weight of 44±2 µg of polymer. For the reservoir layer, the drug:polymer ratio was 1:1.8, and the measured average drug content was 221 µg as determined by Example 2.

[0199] After the coatings were formed on the stents, a select number of stents were tested for the drug release rate from the coatings according to the procedure described in Example 18. It was determined that the average drug released in 24 hours was 129.4 µg, or 58.55% of the total.

Example 23

[0200] 13 mm PENTA stents were coated by spraying a 2% (w/w) solution of EVAL and 98% (w/w) dimethylacetamide. The solvent was removed by baking at 140° C. for 2 hours. A solution of EVAL and 40-O-(2-hydroxy)ethyl-rapamycin in a mixture of 70% (w/w) dimethylacetamide and 30% (w/w) ethanol was spray coated onto the stents. The stents were then baked at 50° C. for 2 hours. A barrier layer was formed by spraying the stents with a solution of EVAL in a mixture of 80% (w/w) dimethylacetamide and 20% (w/w) pentane. Another 2 hour bake at 50° C. was performed to remove the solvent.

[0201] A select number of stents were analyzed to quantify the coating components. For the primer layer, there was a target dry weight of 40 µg of polymer, and a measured average dry weight of 42 µg of polymer. For the reservoir layer, the drug:polymer ratio was 1:1.5, and the measured

average drug content was 184 µg as determined by Example 2. For the barrier layer, the measured average dry weight was 81 µg.

[0202] After the coatings were formed on the stents, a select number of stents were tested for the drug release rate from the coatings according to the procedure described in Example 18. It was determined that the average drug released in 24 hours was 70.1 µg, or 38.1% of the total.

Example 24

[0203] 8 mm PIXEL stents were coated by spraying a 2% (w/w) solution of EVAL and 98% (w/w) dimethylacetamide. The solvent was removed by baking at 140° C. for 2 hours. A solution of EVAL and 40-O-(2-hydroxy)ethyl-rapamycin in a mixture of 70% (w/w) dimethylacetamide and 30% (w/w) ethanol was spray coated onto the stents. The stents were then baked at 50° C. for 2 hours. A barrier layer was formed by spraying the stents with a solution of EVAL in a mixture of 80% (w/w) dimethylacetamide and 20% (w/w) pentane. Another 2 hour bake at 50° C. was performed to remove the solvent.

[0204] A select number of stents were analyzed to quantify the coating components. For the primer layer, there was a target dry weight of 40 µg of polymer, and a measured average dry weight of 45±1 µg of polymer. For the reservoir layer, the drug:polymer ratio was 1:1.75, and the measured average drug content was 200 µg as determined by Example 2. For the barrier layer, the measured average dry weight was 180 µg.

[0205] After the coatings were formed on the stents, a select number of stents were tested for the drug release rate from the coatings according to the procedure described in Example 18. It was determined that the average drug released in 24 hours was 39.0 µg, or 19.5% of the total.

Example 25

[0206] 8 mm PIXEL stents were coated by spraying a 2% (w/w) solution of EVAL and 98% (w/w) dimethylacetamide. The solvent was removed by baking at 140° C. for 2 hours. A solution of EVAL and 40-O-(2-hydroxy)ethyl-rapamycin in a mixture of 70% (w/w) dimethylacetamide and 30% (w/w) ethanol was spray coated onto the stents. The stents were then baked at 50° C. for 2 hours. A barrier layer was formed by spraying the stents with a solution of EVAL in a mixture of 80% (w/w) dimethylacetamide and 20% (w/w) pentane. Another 2 hour bake at 50° C. was performed to remove the solvent.

[0207] A select number of stents were analyzed to quantify the coating components. For the primer layer, there was a target dry weight of 40 µg of polymer, and a measured average dry weight of 41±4 µg of polymer. For the reservoir layer, the drug:polymer ratio was 1:1, and the measured average drug content was 167 µg as determined by Example 2. For the barrier layer, the measured average dry weight was 184 µg.

[0208] After the coatings were formed on the stents, a select number of stents were tested for the drug release rate from the coatings according to the procedure described in Example 18. It was determined that the average drug released in 24 hours was 6.0 µg, or 3.6% of the total.

Example 26

[0209] 8 mm PIXEL stents were coated by spraying a 2% (w/w) solution of EVAL and 98% (w/w) dimethylacetamide. The solvent was removed by baking at 140° C. for 2 hours. A solution of EVAL and 40-O-(2-hydroxy)ethyl-rapamycin in a mixture of 70% (w/w) dimethylacetamide and 30% (w/w) ethanol was spray coated onto the stents. The stents were then baked at 50° C. for 2 hours. A barrier layer was formed by spraying the stents with a solution of EVAL in a mixture of 80% (w/w) dimethylacetamide and 20% (w/w) pentane. Another 2 hour bake at 50° C. was performed to remove the solvent.

[0210] A select number of stents were analyzed to quantify the coating components. For the primer layer, there was a target dry weight of 26 µg of polymer, and a measured average dry weight of 24±2 µg of polymer. For the reservoir layer, the drug:polymer ratio was 1:1.25, and the measured average drug content was 120 µg as determined by Example 2. For the barrier layer, the measured average dry weight was 138 µg.

[0211] After the coatings were formed on the stents, a select number of stents were tested for the drug release rate from the coatings according to the procedure described in Example 18. It was determined that the average drug released in 24 hours was 11.0 µg, or 9.2% of the total.

Example 27

[0212] 13 mm PENTA stents were coated by spraying a 2% (w/w) solution of EVAL and 98% (w/w) dimethylacetamide. The solvent was removed by baking at 140° C. for 2 hours. A solution of EVAL and 40-O-(2-hydroxy)ethyl-rapamycin in a mixture of 70% (w/w) dimethylacetamide and 30% (w/w) ethanol was spray coated onto the stents. The stents were then baked at 50° C. for 2 hours. A barrier layer was formed by spraying the stents with a solution of 1% (w/w) polybutylmethacrylate, 5.7% (w/w) acetone, 50% (w/w) xylene and 43.3% (w/w) HFE FLUX REMOVER (Techspray, Amarillo, Tex.). Another 2 hour bake at 50° C. was performed to remove the solvent.

[0213] A select number of stents were analyzed to quantify the coating components. For the primer layer, there was a target dry weight of 40 µg of polymer, and a measured average dry weight of 44±4 µg of polymer. For the reservoir layer, the drug:polymer ratio was 1:1, and the measured average drug content was 183 µg as determined by Example 2. For the barrier layer, the measured average dry weight was 168 µg.

[0214] After the coatings were formed on the stents, a select number of stents were tested for the drug release rate from the coatings according to the procedure described in Example 18. It was determined that the average drug released in 24 hours was 21.6 µg, or 11.8% of the total.

Example 28

[0215] 13 mm PENTA stents were coated by spraying a 2% (w/w) solution of EVAL and 98% (w/w) dimethylacetamide. The solvent was removed by baking at 140° C. for 2 hours. A solution of EVAL and 40-O-(2-hydroxy)ethyl-rapamycin in a mixture of 70% (w/w) dimethylacetamide and 30% (w/w) ethanol was spray coated onto the stents. The stents were then baked at 50° C. for 2 hours. A barrier layer was formed by spraying the stents with a solution of 1% (w/w) polybutylmethacrylate, 5.7% (w/w) acetone, 50%

(w/w) xylene and 43.3% (w/w) HFE FLUX REMOVER. Another 2 hour bake at 50° C. was performed to remove the solvent.

[0216] A select number of stents were analyzed to quantify the coating components. For the primer layer, there was a target dry weight of 40 µg of polymer, and a measured average dry weight of 41±2 µg of polymer. For the reservoir layer, the drug:polymer ratio was 1:1.8, and the measured average drug content was 102 µg as determined by Example 2. For the barrier layer, the measured average dry weight was 97 µg.

[0217] After the coatings were formed on the stents, a select number of stents were tested for the drug release rate from the coatings according to the procedure described in Example 18. It was determined that the average drug released in 24 hours was 9.1 µg, or 8.9% of the total.

Example 29

[0218] 8 mm PIXEL stents were coated by spraying a 2% (w/w) solution of EVAL and 98% (w/w) dimethylacetamide. The solvent was removed by baking at 140° C. for 2 hours. A solution of EVAL and 40-O-(2-hydroxy)ethyl-rapamycin in a mixture of 70% (w/w) dimethylacetamide and 30% (w/w) ethanol was spray coated onto the stents. The stents were then baked at 50° C. for 2 hours. A barrier layer was formed by spraying the stems with a solution of 1% (w/w) polybutylmethacrylate, 5.7% (w/w) acetone, 50% (w/w) xylene and 43.3% (w/w) HFE FLUX REMOVER (Techspray, Amarillo, Tex.). Another 2 hour bake at 50° C. was performed to remove the solvent.

[0219] A select number of stents were analyzed to quantify the coating components. For the primer layer, there was a target dry weight of 26 µg of polymer, and a measured average dry weight of 27±2 µg of polymer. For the reservoir layer, the drug:polymer ratio was 1:1.25, and the measured average drug content was 120 µg as determined by Example 2. For the barrier layer, the measured average dry weight was 68 µg.

[0220] After the coatings were formed on the stents, a select number of stents were tested for the drug release rate from the coatings according to the procedure described in Example 18. It was determined that the average drug released in 24 hours was 22.0 µg, or 18.3% of the total.

Example 30

[0221] A select number of stents from Example 3 were tested for the drug release rate from the coatings according to the procedure described in Example 18. It was determined that the average drug released in 24 hours was 22.8 µg, or 11.1% of the total.

Example 31

[0222] A select number of stents from Example 4 were tested for the drug release rate from the coatings according to the procedure described in Example 18. It was determined that the average drug released in 24 hours was 57.0 µg, or 20.2% of the total.

Example 32

[0223] Two stents were coated by spraying a 2% (w/w) solution of EVAL and 98% (w/w) dimethylacetamide to form a primer layer. For the primer layer, there was a target dry weight of 100 µg of polymer, and the measured dry

weights were 93 μg and 119 μg , respectively. The two stents were then coated with an EVAL-40-O-(2-hydroxy)ethyl-rapamycin blend at a drug:polymer ratio of 2:1 to produce a reservoir layer. After application, it was determined that the reservoir layers had weights of 610 μg and 590 μg , respectively. From the total weight of the reservoir layers and the drug:polymer ratio, it was estimated that the coatings contained about 407 μg and 393 μg of 40-O-(2-hydroxy)ethyl-rapamycin, respectively. Polymeric barrier layers were also applied to the stents and it was determined that the weights of the barrier layers were 279 μg and 377 μg , respectively.

[0224] The stents from this Example were then sterilized using an ethylene oxide sterilization process. In particular, the stents were placed in a chamber and exposed to ethylene oxide gas for 6 hours at 130-140° F., with a relative humidity of 45-80%. The stents were then aerated for about 72 hours at 110-130° F.

[0225] After sterilization, the coatings were then analyzed using an HPLC to determine the peak purity of the drug in the stent coatings. It was determined that the 40-O-(2-hydroxy)ethyl-rapamycin in the coatings had peak purities of about greater than 95%. FIG. 4 is a chromatograph showing the peak purity the 40-O-(2-hydroxy)ethyl-rapamycin in one of the coatings, labeled "ETO," as compared to a reference standard for 40-O-(2-hydroxy)ethyl-rapamycin, labeled "Ref. Std."

Example 33

[0226] Two stents were coated by spraying a 2% (w/w) solution of EVAL and 98% (w/w) dimethylacetamide to form a primer layer. For the primer layer, there was a target dry weight of 100 μg of polymer, and the measured dry weights were 99 μg and 94 μg , respectively. The two stents were then coated with an EVAL-40-O-(2-hydroxy)ethyl-rapamycin blend at a drug:polymer ratio of 2:1 to produce a reservoir layer. After application, it was determined that the reservoir layers had weights of 586 μg and 588 μg , respectively. From the total weight of the reservoir layers and the drug:polymer ratio, it was estimated that the coatings contained about 391 μg and 392 μg of 40-O-(2-hydroxy)ethyl-rapamycin, respectively. Polymeric barrier layers were also applied to the stents and it was determined that the weights of the barrier layers were 380 μg and 369 μg , respectively.

[0227] The stents from this Example were then sterilized using an e-beam sterilization process. In particular, the stents were placed in a stent container which was run through an e-beam chamber. While moving through the e-beam chamber via a conveyor belt, the stent container was exposed to an e-beam with a constant energy level so that the stent container received between 33.11 and 46.24 KGy. The stent therefore at any point along the length of the stent received at a minimum 25 KGy.

[0228] After sterilization, the coating was then analyzed using an HPLC to determine the peak purity of the drug in the stent coating. It was determined that the 40-O-(2-hydroxy)ethyl-rapamycin in the coating had a peak purity of about greater than 95%. FIG. 4 is a chromatograph showing the peak purity the 40-O-(2-hydroxy)ethyl-rapamycin in one of the coatings, labeled "e-beam," as compared to a reference standard for 40-O-(2-hydroxy)ethyl-rapamycin, labeled "Ref. Std."

Example 34

[0229] 13 mm PENTA stents were coated by spraying a 2% (w/w) solution of EVAL and 98% (w/w) dimethylacet-

amide. The solvent was removed by baking at 140° C. for 2 hours. A solution of EVAL and 40-O-(2-hydroxy)ethyl-rapamycin in a mixture of 70% (w/w) dimethylacetamide and 30% (w/w) ethanol was spray coated onto the stents. The stents were then baked at 50° C. for 2 hours. A barrier layer was formed by spraying the stents with a solution of EVAL in a mixture of 80% (w/w) dimethylacetamide and 20% (w/w) pentane. Another 2 hour bake at 50° C. was performed to remove the solvent.

[0230] A select number of stems were analyzed to quantify the coating components. For the primer layer, there was a target dry weight of 40 μg of polymer, and a measured average dry weight of 44 \pm 3 μg of polymer. For the reservoir layer, the drug:polymer ratio was 1:2, and the measured average drug content was 245 μg as determined by Example 2. For the barrier layer, the measured average dry weight was 104 μg .

[0231] After the coatings were formed on the stents, a select number of stents were tested for the drug release rate from the coatings according to the procedure described in Example 18. It was determined that the average drug released in 24 hours was 23.5 μg , or 9.6% of the total.

Example 35

[0232] 13 mm PENTA stents were coated by spraying a 2% (w/w) solution of EVAL and 98% (w/w) dimethylacetamide. The solvent was removed by baking at 140° C. for 2 hours. A solution of EVAL and 40-O-(2-hydroxy)ethyl-rapamycin in a mixture of 70% (w/w) dimethylacetamide and 30% (w/w) ethanol was spray coated onto the stents. The stents were then baked at 50° C. for 2 hours. A barrier layer was formed by spraying the stents with a solution of EVAL in a mixture of 80% (w/w) dimethylacetamide and 20% (w/w) pentane. Another 2 hour bake at 50° C. was performed to remove the solvent.

[0233] A select number of stents were analyzed to quantify the coating components. For the primer layer, there was a target dry weight of 40 μg of polymer, and a measured average dry weight of 45 \pm 3 μg of polymer. For the reservoir layer, the drug:polymer ratio was 1:1.5, and the measured average drug content was 337 μg as determined by Example 2. For the barrier layer, the measured average dry weight was 169 μg .

[0234] After the coatings were formed on the stents, a select number of stents were tested for the drug release rate from the coatings according to the procedure described in Example 18. It was determined that the average drug released in 24 hours was 37.1 μg , or 11.0% of the total.

Example 36

[0235] Stents from Example 34 and stents from Example 35 were sterilized according to the process described in Example 32. The released rates of the drug in the stent coatings of sterilized stents and non-sterilized were then tested according to the process described in Example 5. The results of the release rate test are graphically shown in FIG. 5.

Example 37

[0236] A 13 mm PENTA stent can be coated by spraying a solution of EVAL, 40-O-(2-hydroxy)ethyl-rapamycin and ethanol onto the stent. The stent is then baked at 50° C. for 2 hours to yield a reservoir coating with 300 μg of EVAL and

300 µg of 40-O-(2-hydroxy)ethyl-rapamycin. A barrier layer can be formed by spraying the stent with a solution of EVAL and pentane. A second 2 hour bake at 50° C. can be performed to remove the solvent to yield a barrier coating with 320 µg of EVAL.

Example 38

[0237] A 13 mm PENTA stent can be coated by spraying a solution of EVAL and DMAC onto the stent. The solvent is removed by baking at 140° C. for 2 hours to yield a primer coating with 100 µg of EVAL. A reservoir layer can be applied by spraying a solution of EVAL, 40-O-(2-hydroxy)ethyl-rapamycin and ethanol onto the stent. The stent is then baked at 50° C. for 2 hours to yield a reservoir coating with 200 µg of EVAL and 400 µg of 40-O-(2-hydroxy)ethyl-rapamycin. A barrier layer can be formed by spraying the stent with a solution of EVAL and pentane. A second 2 hour bake at 50° C. is performed to remove the solvent to yield a barrier coating with 350 µg of EVAL.

Example 39

[0238] A 13 mm PENTA stent can be coated by spraying a solution of EVAL, 40-O-(2-hydroxy)ethyl-rapamycin and ethanol onto the stent. The stent is then baked at 50° C. for 2 hours to yield a reservoir coating with 500 µg of EVAL and 250 µg of 40-O-(2-hydroxy)ethyl-rapamycin. A barrier layer can be formed by spraying the stent with a solution of EVAL and pentane. A second 2 hour bake at 50° C. is performed to remove the solvent to yield a barrier coating with 300 µg of EVAL.

Example 40

[0239] A 13 mm PENTA stent can be coated by spraying a solution of EVAL, 40-O-(2-hydroxy)ethyl-rapamycin and ethanol onto the stent. The stent is then baked at 50° C. for 2 hours to yield a reservoir coating with 475 µg of EVAL and 175 µg of 40-O-(2-hydroxy)ethyl-rapamycin. A barrier layer can be formed by spraying the stent with a solution of EVAL and pentane. A second 2 hour bake at 50° C. is performed to remove the solvent to yield a barrier coating with 300 µg of EVAL.

Example 41

[0240] An 8 mm PIXEL stent can be coated by spraying a solution of EVAL and 40-O-(2-hydroxy)ethyl-rapamycin in a mixture of dimethylacetamide and ethanol onto the stent. The stent is then baked at 50° C. for 2 hours to yield a reservoir coating with 400 µg of EVAL and 200 µg of 40-O-(2-hydroxy)ethyl-rapamycin. A barrier layer can be formed by spraying the stent with a solution of EVAL and a mixture of dimethylacetamide and pentane. A second 2 hour bake at 50° C. is performed to remove the solvent to yield a barrier coating with 300 µg of EVAL.

Example 42

[0241] An 8 mm Pixel stent can be coated by spraying a solution of EVAL and 40-O-(2-hydroxy)ethyl-rapamycin in a mixture of dimethylacetamide and ethanol onto the stent. The stent is then baked at 50° C. for 2 hours to yield a reservoir coating with 400 µg of EVAL and 200 µg of 40-O-(2-hydroxy)ethyl-rapamycin. A barrier layer can be formed by spraying the stent with a solution of polybutyl-

methacrylate ("PBMA") and HFE FLUX REMOVER. A second 2 hour bake at 50° C. is performed to remove the solvent to yield a barrier coating with 150 µg of PBMA.

Example 43

[0242] An 8 mm PIXEL stent can be coated by spraying a solution of EVAL and 40-O-(2-hydroxy)ethyl-rapamycin in a mixture of dimethylacetamide and ethanol onto the stent. The stent is then baked at 50° C. for 2 hours to yield a reservoir coating with 200 µg of EVAL and 200 µg of 40-O-(2-hydroxy)ethyl-rapamycin. A barrier layer can be formed by spraying the stent with a solution of EVAL and a mixture of dimethylacetamide and pentane. A second 2 hour bake at 50° C. is performed to remove the solvent to yield a barrier coating with 200 µg of EVAL.

Example 44

[0243] An 8 mm PIXEL stent can be coated by spraying a solution of EVAL and 40-O-(2-hydroxy)ethyl-rapamycin in a mixture of dimethylacetamide and ethanol onto the stent. The stent is then baked at 50° C. for 2 hours to yield a reservoir coating with 200 µg of EVAL and 200 µg of 40-O-(2-hydroxy)ethyl-rapamycin. A barrier layer can be formed by spraying the stent with a solution of PBMA and HFE FLUX REMOVER. A second 2 hour bake at 50° C. is performed to remove the solvent to yield a barrier coating with 150 µg of PBMA.

Example 45

[0244] An 8 mm PIXEL stent can be coated by spraying a solution of EVAL and 40-O-(2-hydroxy)ethyl-rapamycin in a mixture of dimethylacetamide and ethanol onto the stent. The stent is then baked at 50° C. for 2 hours to yield a reservoir coating with 200 µg of EVAL and 200 µg of 40-O-(2-hydroxy)ethyl-rapamycin. A barrier layer can be formed by spraying the stent with a solution of EVAL and a mixture of dimethylacetamide and pentane. A second 2 hour bake at 50° C. is performed to remove the solvent to yield a barrier coating with 200 µg of EVAL.

Example 46

[0245] An 8 mm PIXEL stent can be coated by spraying a solution of EVAL and 40-O-(2-hydroxy)ethyl-rapamycin in a mixture of dimethylacetamide and ethanol onto the stent. The stent is then baked at 50° C. for 2 hours to yield a reservoir coating with 200 µg of EVAL and 200 µg of 40-O-(2-hydroxy)ethyl-rapamycin. A barrier layer can be formed by spraying the stent with a solution of PBMA and HFE FLUX REMOVER. A second 2 hour bake at 50° C. is performed to remove the solvent to yield a barrier coating with 100 µg of PBMA.

Example 47

[0246] An 8 mm PIXEL stent can be coated by spraying a solution of EVAL and 40-O-(2-hydroxy)ethyl-rapamycin in a mixture of dimethylacetamide and ethanol onto the stent. The stent is then baked at 50° C. for 2 hours to yield a reservoir coating with 270 µg of EVAL and 150 µg of 40-O-(2-hydroxy)ethyl-rapamycin. A barrier layer can be formed by spraying the stent with a solution of EVAL and a mixture of dimethylacetamide and pentane. A second 2 hour

bake at 50° C. is performed to remove the solvent to yield a barrier coating with 150 µg of EVAL.

Example 48

[0247] An 8 mm PIXEL stent can be coated by spraying a solution of EVAL and 40-O-(2-hydroxy)ethyl-rapamycin in a mixture of dimethylacetamide and ethanol onto the stent. The stent is then baked at 50° C. for 2 hours to yield a reservoir coating with 170 µg of EVAL and 150 µg of 40-O-(2-hydroxy)ethyl-rapamycin. A barrier layer can be formed by spraying the stent with a solution of PBMA and HFE FLUX REMOVER. A second 2 hour bake at 50° C. is performed to remove the solvent to yield a barrier coating with 75 µg of PBMA.

Example 49

[0248] An 8 mm PIXEL stent can be coated by spraying a solution of EVAL and 40-O-(2-hydroxy)ethyl-rapamycin in a mixture of dimethylacetamide and ethanol onto the stent. The stent is then baked at 50° C. for 2 hours to yield a reservoir coating with 150 µg of EVAL and 150 µg of 40-O-(2-hydroxy)ethyl-rapamycin. A barrier layer can be formed by spraying the stent with a solution of EVAL and a mixture of dimethylacetamide and pentane. A second 2 hour bake at 50° C. is performed to remove the solvent to yield a barrier coating with 200 µg of EVAL. A finishing layer can then be applied by spraying the stent with a solution of EVAL, polyethyleneoxide (molecular weight of 17.5 K) ("PEO") and dimethylacetamide. The stent is baked at 50° C. for 2 hours to remove the solvent to yield a finishing coating with 83 µg of EVAL and 17 µg of PEO.

Example 50

[0249] An 8 mm PIXEL stent can be coated by spraying a solution of EVAL and 40-O-(2-hydroxy)ethyl-rapamycin in a mixture of dimethylacetamide and ethanol onto the stent. The stent is then baked at 50° C. for 2 hours to yield a reservoir coating with 270 µg of EVAL and 150 µg of 40-O-(2-hydroxy)ethyl-rapamycin. A barrier layer can be formed by spraying the stent with a solution of EVAL and a mixture of dimethylacetamide and pentane. A second 2 hour bake at 50° C. is performed to remove the solvent to yield a barrier coating with 150 µg of EVAL. A finishing layer can then be applied by spraying the stem with a solution of EVAL, PEO and dimethylacetamide. The stent is baked at 50° C. for 2 hours to remove the solvent to yield a finishing coating with 83 µg of EVAL and 17 µg of PEO.

Example 51

[0250] An 8 mm PIXEL stent can be coated by spraying a solution of EVAL and 40-O-(2-hydroxy)ethyl-rapamycin in a mixture of dimethylacetamide and ethanol onto the stent. The stent is then baked at 50° C. for 2 hours to yield a reservoir coating with 200 µg of EVAL and 200 µg of 40-O-(2-hydroxy)ethyl-rapamycin. A barrier layer can be formed by spraying the stent with a solution of EVAL and a mixture of dimethylacetamide and pentane. A second 2 hour bake at 50° C. is performed to remove the solvent to yield a barrier coating with 100 µg of EVAL.

Example 52

[0251] An 8 mm PIXEL stent can be coated by spraying a solution of EVAL and 40-O-(2-hydroxy)ethyl-rapamycin in a mixture of dimethylacetamide and ethanol onto the stent. The stent is then baked at 50° C. for 2 hours to yield a reservoir coating with 200 µg of EVAL and 200 µg of 40-O-(2-hydroxy)ethyl-rapamycin. A barrier layer can be formed by spraying the stent with a solution of EVAL, KYNAR and HFE FLUX REMOVER. A second 2 hour bake at 50° C. is performed to remove the solvent to yield a barrier coating with 50 µg of EVAL and 50 µg of KYNAR.

Example 53

[0252] An 8 mm PIXEL stent can be coated by spraying a solution of EVAL and 40-O-(2-hydroxy)ethyl-rapamycin in a mixture of dimethylacetamide and ethanol onto the stent. The stent is then baked at 50° C. for 2 hours to yield a reservoir coating with 350 µg of EVAL and 200 µg of 40-O-(2-hydroxy)ethyl-rapamycin. A barrier layer is formed by spraying the stent with a solution of EVAL and a mixture of dimethylacetamide and pentane. A second 2 hour bake at 50° C. is performed to remove the solvent to yield a barrier coating with 200 µg of EVAL.

Example 54

[0253] An 8 mm PIXEL stent can be coated by spraying a solution of EVAL and 40-O-(2-hydroxy)ethyl-rapamycin in a mixture of dimethylacetamide and ethanol onto the stent. The stent is then baked at 50° C. for 2 hours to yield a reservoir coating with 350 µg of EVAL and 200 µg of 40-O-(2-hydroxy)ethyl-rapamycin. A barrier layer can be formed by spraying the stent with a solution of PBMA and HFE FLUX REMOVER. A second 2 hour bake at 50° C. is performed to remove the solvent to yield a barrier coating with 100 µg of PBMA.

Example 55

[0254] An 8 mm PIXEL stent can be coated by spraying a solution of EVAL and 40-O-(2-hydroxy)ethyl-rapamycin in a mixture of dimethylacetamide and ethanol onto the stent. The stent is then baked at 50° C. for 2 hours to yield a reservoir coating with 350 µg of EVAL and 200 µg of 40-O-(2-hydroxy)ethyl-rapamycin. A barrier layer can be formed by spraying the stent with a solution of EVAL and a mixture of dimethylacetamide and pentane. A second 2 hour bake at 50° C. is performed to remove the solvent to yield a barrier coating with 200 µg of EVAL.

Example 56

[0255] An 8 mm PIXEL stent is coated by spraying a solution of EVAL and 40-O-(2-hydroxy)ethyl-rapamycin in a mixture of dimethylacetamide and ethanol onto the stent. The stent is then baked at 50° C. for 2 hours to yield a reservoir coating with 350 µg of EVAL and 200 µg of 40-O-(2-hydroxy)ethyl-rapamycin. A barrier layer can be formed by spraying the stent with a solution of EVAL and a mixture of dimethylacetamide and pentane. A second 2 hour bake at 50° C. is performed to remove the solvent to yield a barrier coating with 100 µg of EVAL. A finishing layer can then be applied by spraying the stent with a solution of EVAL, PEO and dimethylacetamide. The stent is baked at

50° C. for 2 hours to remove the solvent to yield a finishing coating with 83 µg of EVAL and 17 µg of PEO.

Example 57

[0256] An 8 mm PIXEL stent can be coated by spraying a solution of EVAL and 40-O-(2-hydroxy)ethyl-rapamycin in a mixture of dimethylacetamide and ethanol onto the stent. The stent is then baked at 50° C. for 2 hours to yield a reservoir coating with 350 µg of EVAL and 200 µg of 40-O-(2-hydroxy)ethyl-rapamycin. A barrier layer can be formed by spraying the stent with a solution of PBMA and HFE FLUX REMOVER. A second 2 hour bake at 50° C. is performed to remove the solvent to yield a barrier coating with 75 µg of PBMA. A finishing layer can then be applied by spraying the stent with a solution of PBMA, PEO and dimethylacetamide. The stent is baked at 50° C. for 2 hours to remove the solvent to yield a finishing coating with 62.5 µg of PBMA and 12.5 µg of PEO.

[0257] While particular embodiments of the present invention have been shown and described, it will be obvious to those skilled in the art that changes and modifications can be made without departing from this invention in its broader aspects.

What is claimed is:

1. A stent comprising a radially expandable body and a coating covering at least a portion of the body, the coating containing 40-O-(2-hydroxy)ethyl-rapamycin, or an analog or derivative thereof, wherein the release rate of the 40-O-(2-hydroxy)ethyl-rapamycin, or the analog or derivative thereof, in 24 hours after the implantation of the stent is less than about 50% of the total amount contained in the coating.
2. The stent of claim 1, wherein the derivative or analogue of 40-O-(2-hydroxy)ethyl-rapamycin includes 40-O-(3-hydroxy)propyl-rapamycin and 40-O-[2-(2-hydroxy)ethoxy]ethyl-rapamycin.
3. The stent of claim 1, wherein the coating comprises an ethylene vinyl alcohol copolymer.
4. The stent of claim 1, wherein the coating is made from a polymer including a first region having a first degree of crystallinity and a second region having a second degree of crystallinity, the second degree of crystallinity being greater than the first degree of crystallinity.
5. The stent of claim 4, wherein the second region is positioned beneath the first region.

* * * * *