



2d

1 .

2 .

\*\*\*

\*\*\*

21 : 22 :

23 : 24 :

25 : 26 : 1

27 : / 28 : 2

29 : / 30 :

31 : 32 :

/ ,  
(Replacement Gate Process)

가 .(IEDM98 p.777) , 가

가 .(ED - 42)  
(1) p.94, EDL - 17(4) 0.157, IEDM97 p.821, IEDM98 p.785)

1a 1d .

(2)가 (4) (1) (3) (4) , 가  
(4) (3)

(1) / (5) 1 ;  
(6) , 가 2 ;  
(4) (3) , (1) (7) (1) 3  
; (8) , (6)

4 .

, 1a (2)가 (1) (3), (4)  
, 가 (4) (3) .

(5) , (1) /

, / (5) (5) . 가가

, 1b (6) ,

가

, 1c (4) (3) ,

(1) (7) (1) .

, , / (7) (5) .

가 ,

, 1d (8) , (6)

. (7)

(7) .

/

가 ,  
가 가 ,

가가 / ,

, 가

, 가 1 ;

1 / 1 , 2  
 1 / 2 ; ,  
 3 ; 가 4 ,  
 2a 2d  
 , 2a 가 (22)가 (21) (23), (24)  
 , (21) (24) (23)  
 (25) (23)  
 (25) (23)  
 , 2b 1 (26) , 1 (21) /  
 (27) .  
 1 (26) / (27)  
 / (27)  
 , (23) / 가  
 , 2 1 (26) 2  
 (28) (21) / (29)  
 , / (27), / (29)  
 (25) (21) .  
 , 2c 가 (24) (30) (24)  
 , 2d (Vth) , (31) (23) (21)  
 (30) (32)  
 , (23) (24) , (31)  
 (31) (31)  
 (31) / (27,29) (23) / (27,29)

가 / , , 2 /  
/ , 가 .

(57)

1.

가 , , 가  
1 ; 1  
1 , 2 1 / 2 2  
; , 3 ; 가  
4 , .

2.

1 , 4 , .

1a

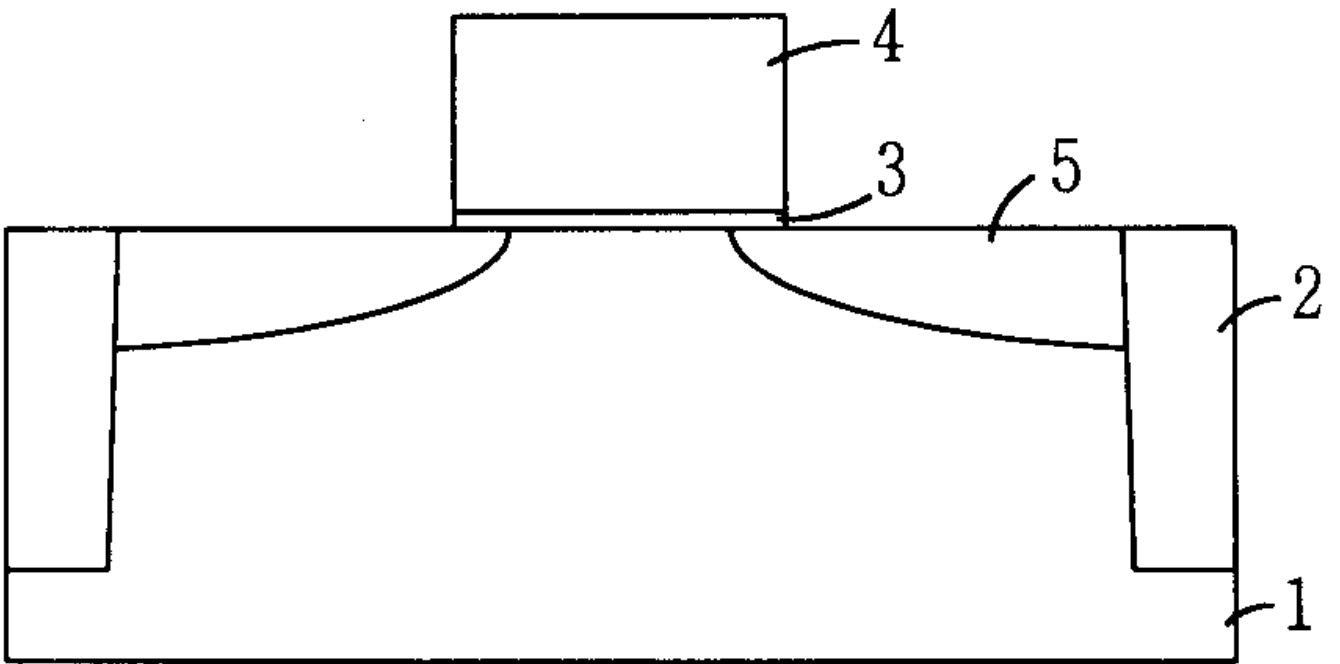

1b

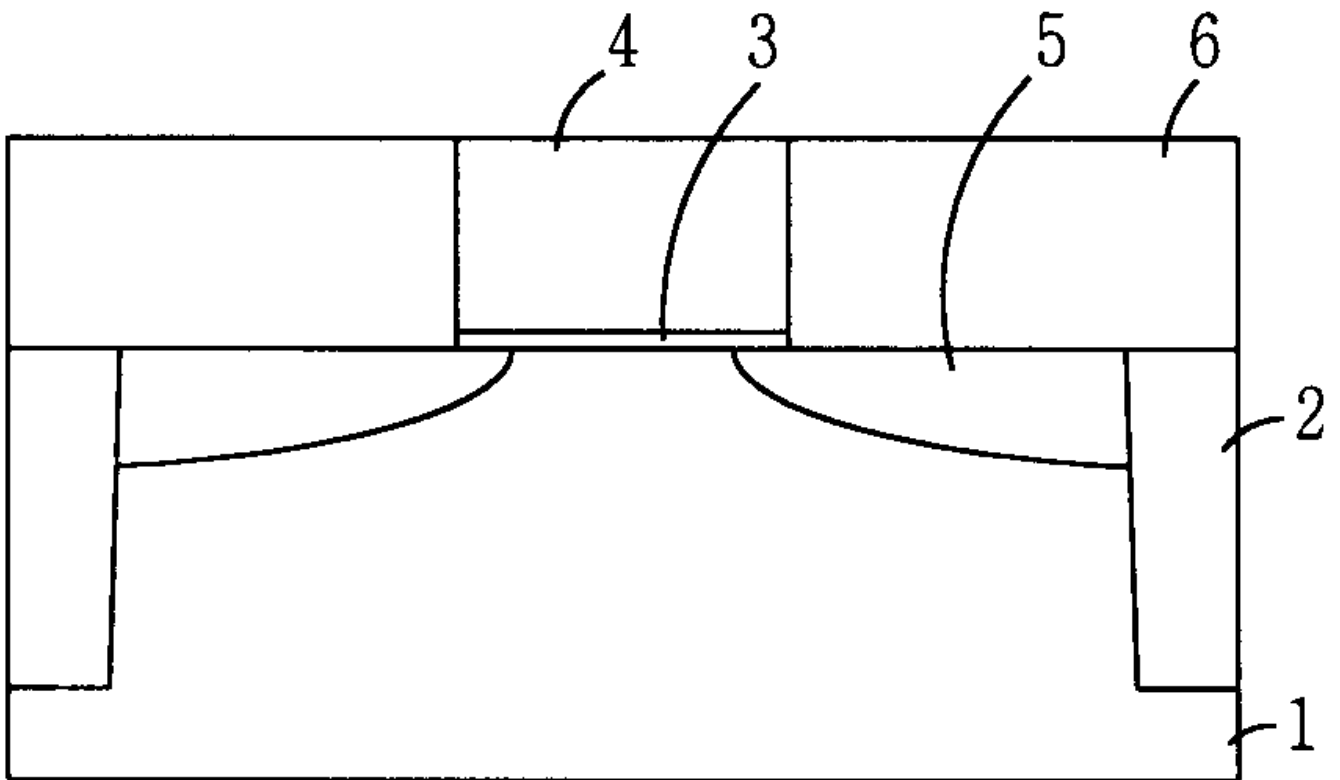

1c

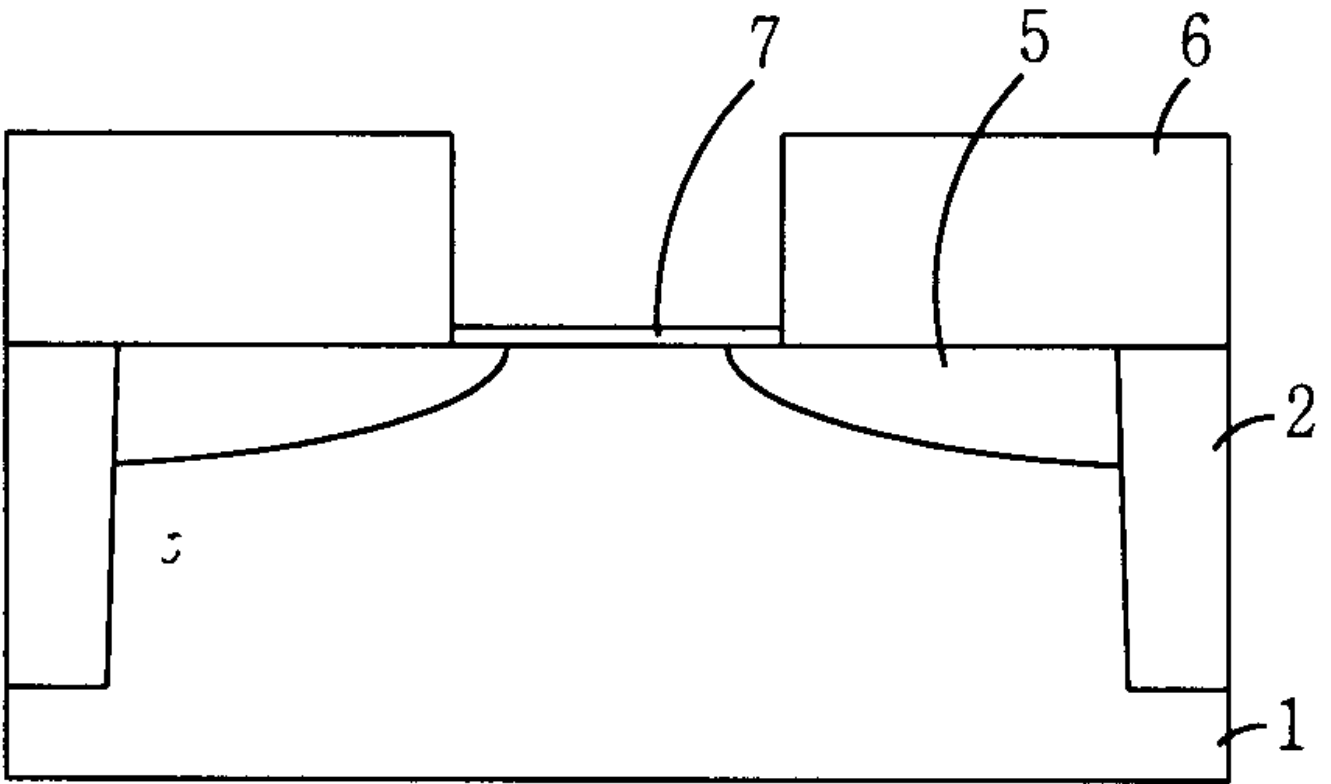

1d

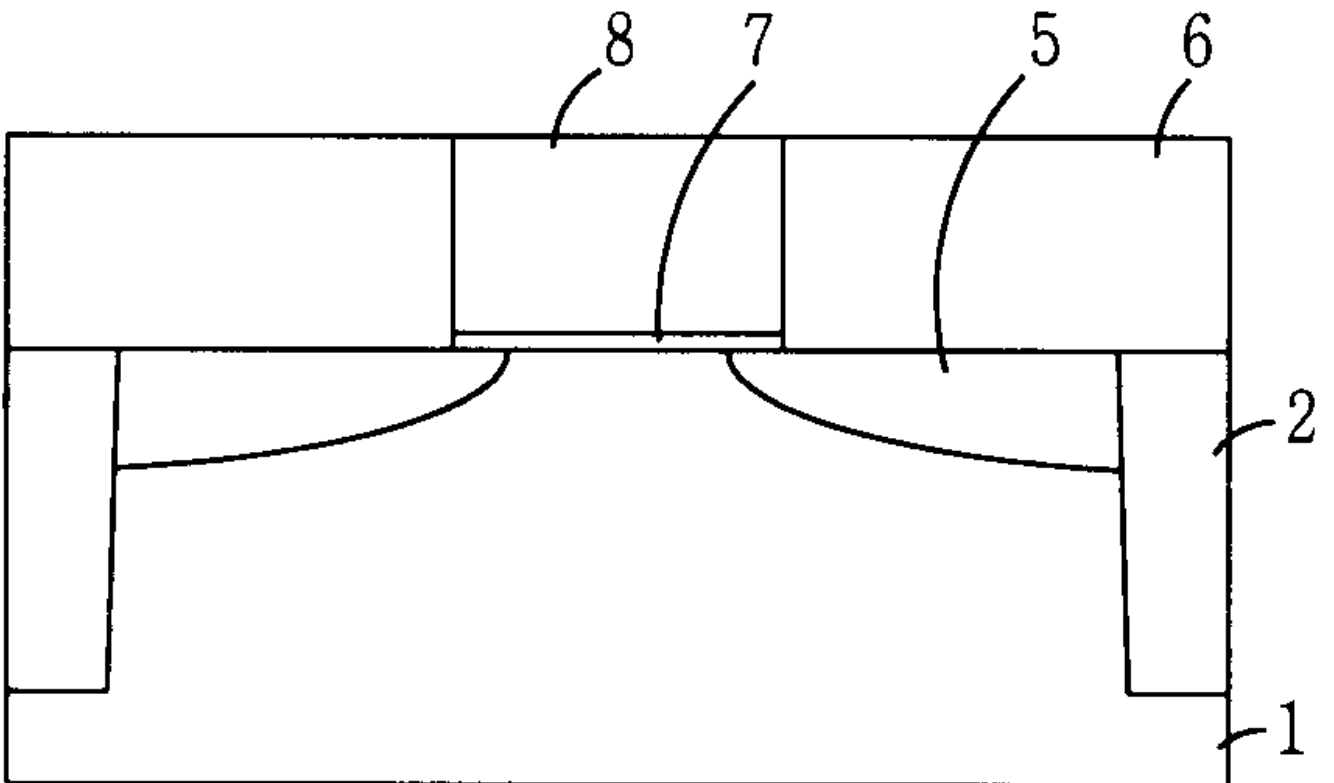

2a

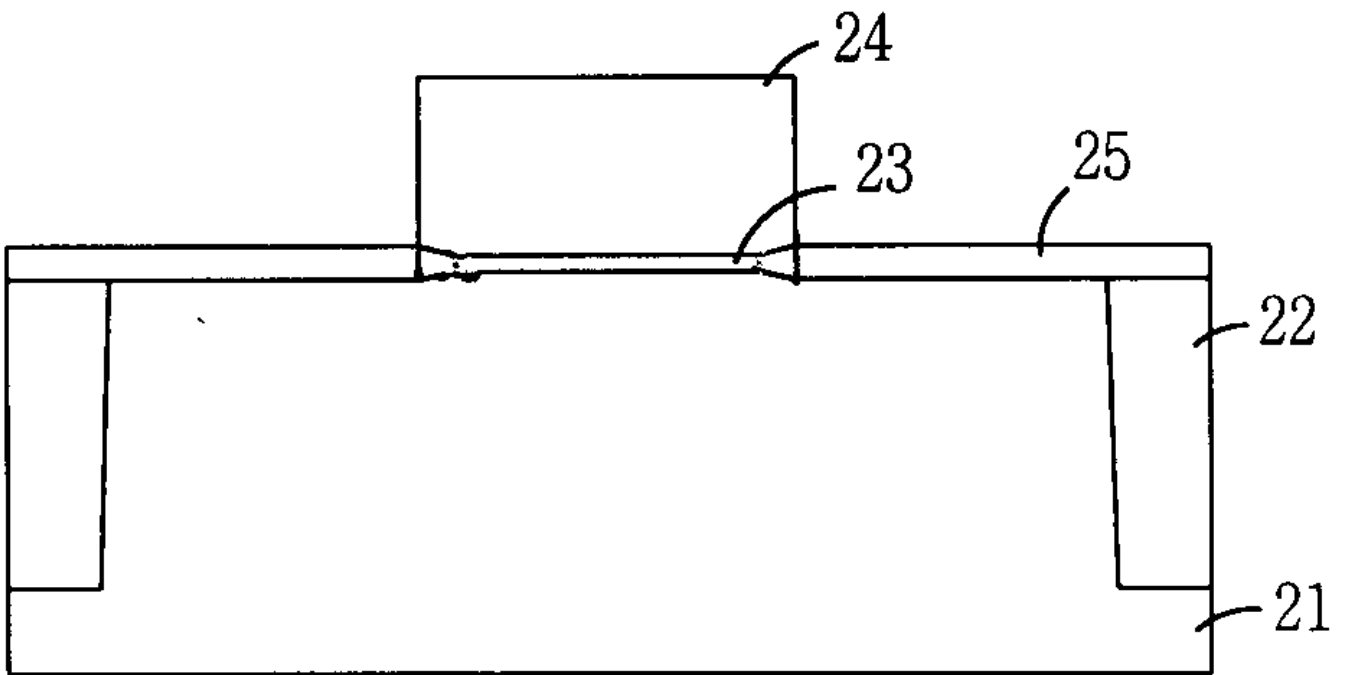

2b

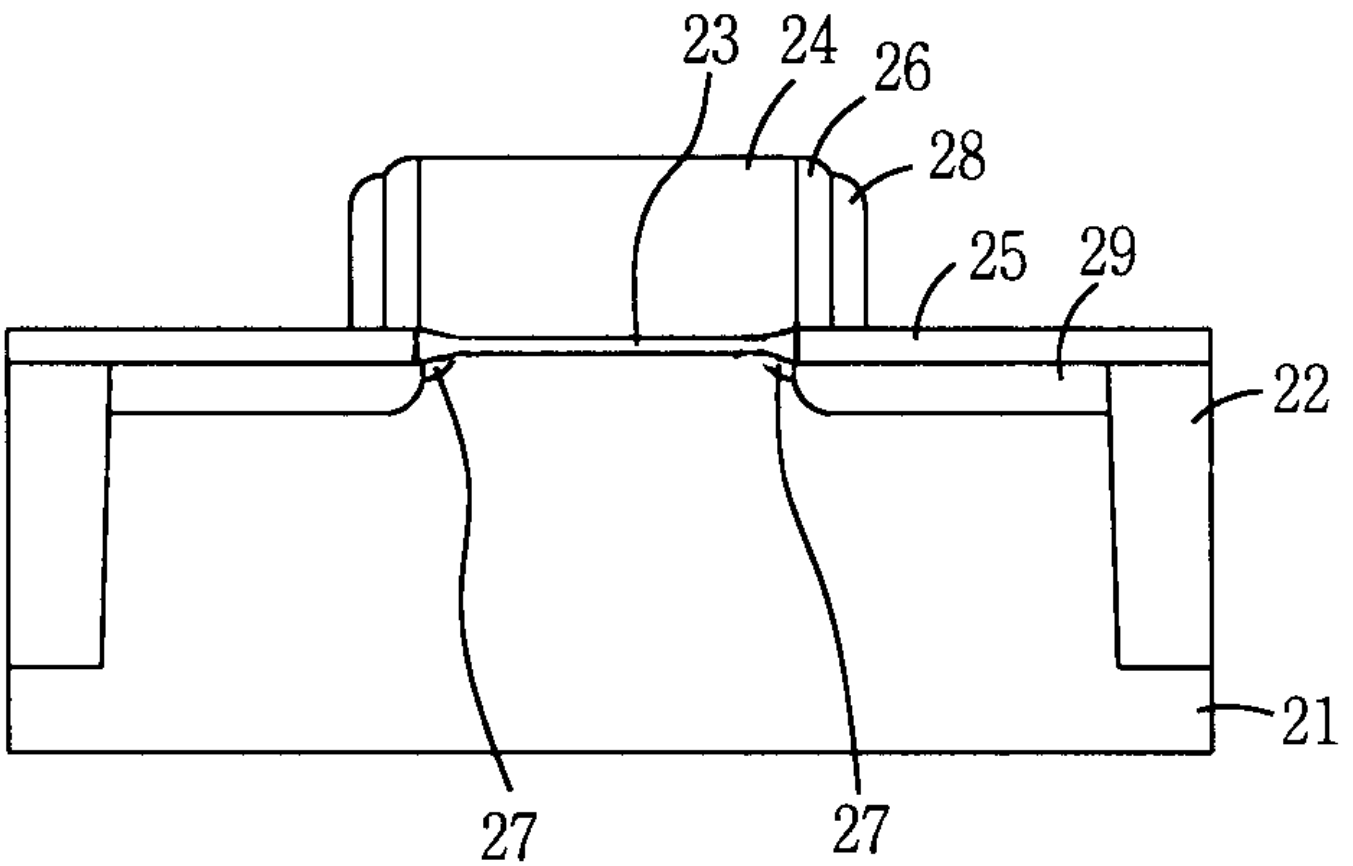



2c

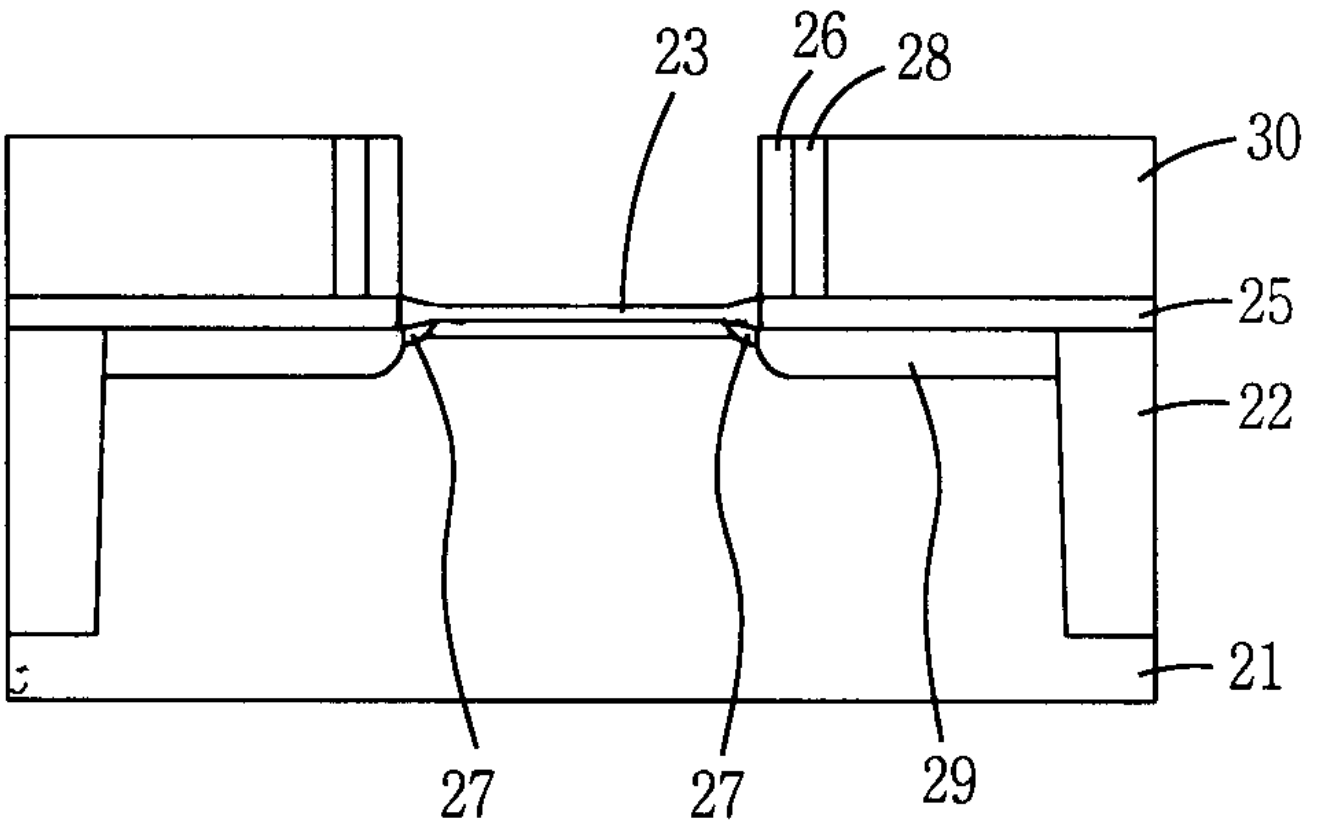

2d

