

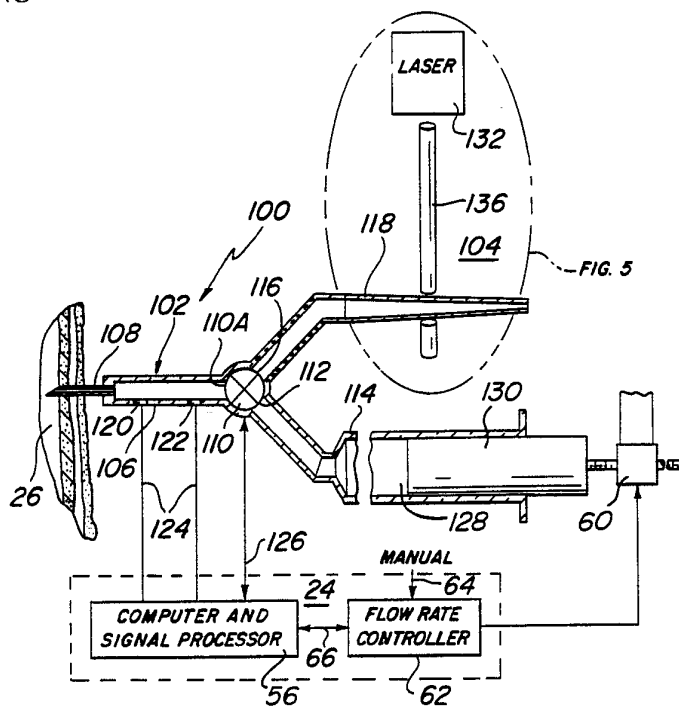

INTERNATIONAL APPLICATION PUBLISHED UNDER THE PATENT COOPERATION TREATY (PCT)

<p>(51) International Patent Classification ⁵ : G01N 33/49</p>	<p>A1</p>	<p>(11) International Publication Number: WO 92/15878 (43) International Publication Date: 17 September 1992 (17.09.92)</p>
<p>(21) International Application Number: PCT/US92/01251 (22) International Filing Date: 19 February 1992 (19.02.92) (30) Priority data: 663,990 4 March 1991 (04.03.91) US (71) Applicant: KENSEY NASH CORPORATION [US/US]; Marsh Creek Corporate Center, 55 East Uwchlan Avenue, Suite 204, Exton, PA 19341 (US). (72) Inventors: CHO, Young ; 8 Niamoa Drive, Cherry Hill, NJ 08003 (US). KENSEY, Kenneth ; 8 Hickory Lane, Chester Springs, PA 19425 (US). (74) Agent: FAIGUS, Martin, L.; Caesar, Rivise, Bernstein, Cohen & Pokotilow, Ltd., 12th Floor, Seven Penn Center, 1635 Market Street, Philadelphia, PA 19103-2212 (US).</p>		<p>(81) Designated States: AT (European patent), AU, BB, BE (European patent), BF (OAPI patent), BG, BJ (OAPI patent), BR, CA, CF (OAPI patent), CG (OAPI patent), CH (European patent), CI (OAPI patent), CM (OAPI patent), DE (European patent), DK (European patent), ES (European patent), FI, FR (European patent), GA (OAPI patent), GB (European patent), GN (OAPI patent), GR (European patent), HU, IT (European patent), JP, KP, KR, LK, LU (European patent), MC (European patent), MG, ML (OAPI patent), MR (OAPI patent), MW, NL (European patent), NO, RO, RU, SD, SE (European patent), SN (OAPI patent), TD (OAPI patent), TG (OAPI patent).</p> <p>Published <i>With international search report.</i> <i>Before the expiration of the time limit for amending the claims and to be republished in the event of the receipt of amendments.</i></p>

(54) Title: APPARATUS AND METHOD FOR DETERMINING DEFORMABILITY OF RED BLOOD CELLS OF A LIVING BEING



(57) Abstract

Apparatus (20, 100) and methods for determining the deformability of the red blood cells of a living being. In one embodiment the apparatus (20) comprises a sampling unit (22) arranged to be coupled to a blood vessel (26) of the being for withdrawing a portion of the blood of the being at substantially the time that said portion of said blood is flowing through said vessel to calculate the deformability of red blood cells. In another embodiment the apparatus (100) comprises a viewing system (104) to provide direct visualization of the red blood cells and also includes a unit (24) for calculating blood viscosity to correlate that information with the perceived red blood cell deformability.

FOR THE PURPOSES OF INFORMATION ONLY

Codes used to identify States party to the PCT on the front pages of pamphlets publishing international applications under the PCT.

AT	Austria	FI	Finland	MI	Mali
AU	Australia	FR	France	MN	Mongolia
BB	Barbados	GA	Gabon	MR	Mauritania
BE	Belgium	GB	United Kingdom	MW	Malawi
BF	Burkina Faso	GN	Guinea	NI	Netherlands
BG	Bulgaria	GR	Greece	NO	Norway
BJ	Benin	HU	Hungary	PL	Poland
BR	Brazil	IE	Ireland	RO	Romania
CA	Canada	IT	Italy	RU	Russian Federation
CF	Central African Republic	JP	Japan	SD	Sudan
CG	Congo	KP	Democratic People's Republic of Korea	SE	Sweden
CH	Switzerland	KR	Republic of Korea	SN	Senegal
CI	Côte d'Ivoire	LI	Liechtenstein	SU	Soviet Union
CM	Cameroon	LK	Sri Lanka	TD	Chad
CS	Czechoslovakia	LU	Luxembourg	TG	Togo
DE	Germany	MC	Monaco	US	United States of America
DK	Denmark	MG	Madagascar		
ES	Spain				

1

APPARATUS AND METHOD FOR
DETERMINING DEFORMABILITY OF
RED BLOOD CELLS OF A LIVING BEING

Field of the Invention

This invention relates generally to medical instruments for and methods of determining the deformability of red blood cells in a living being.

Background of the invention

Conventional wisdom in the medical community used to be that heart attacks and strokes were primarily attributable to severe narrowing of the arteries due to vascular disease, e.g., atherosclerosis and/or arteriosclerosis. However, it has been found that even in some patient's free of substantial arterial disease, or other high risk factors, e.g., high cholesterol, high blood pressure, etc., the risk of heart attack/stroke is still great. Thus, today many investigators are focussing upon the blood's constituents, physical characteristics, and its effects (sometimes referred to as "hemodynamic effects") upon the vascular system and associated organs to identify heart attack/stroke risk factors and from that knowledge develop effective therapy. Moreover, hemodynamic effects of the blood may, per se, play a role in the etiology of arterial disease.

Thus, one characteristic of the blood now being investigated from a hemodynamic standpoint to determine its affect on vascular disease and the risk of heart attack and/or stroke is the effect of the deformability of the red blood cells on the being.

Objects of the Invention

Accordingly, it is the general object of this invention to provide apparatus and methods of determining the deformability of the red blood cells of a living being.

It is a further object of this invention to provide apparatus and methods of determining the deformability of the red blood cells of a living being at substantially the time that those cells flow through the body of the being.

It is still a further object of this invention to provide apparatus for determining the deformability of the red blood cells of a living being, which apparatus is simple in construction, easy to use, and accurate.

Summary of the Invention

These and other objects of the instant invention are achieved by providing apparatus and a method for determining the deformability of the red blood cells of a living being.

The apparatus basically comprises sampling means arranged to be coupled to a blood vessel of the being for monitoring a portion of the being's blood at substantially the time that portion of the blood is flowing through the blood vessel to determine the deformability of red blood cells.

In one embodiment of the apparatus the sampling means comprises means, e.g., a needle, to enable the portion of the blood to flow into passageway means. That means comprises first and second passageways for the red blood cells to freely flow therethrough, and a restricted passageway between the first and second passageways. The cross sectional area of the restricted passageway is smaller than that of a typical red blood cell. First means, e.g., a pair of solid state transducers, are provided for determining a pressure differential between two longitudinally spaced apart points in the first passageway. Second means, e.g., another pair of solid state transducers, are provided for determining a pressure differential between two longitudinally spaced apart points in the second passageway. Third means is provided for establishing the flow rate of the portion of blood flowing through the sampling means adjacent the points. The pressure differentials enable the deformability of the red blood cells to be determined.

In another embodiment of the apparatus the sampling means comprises means, e.g., a needle, to enable the portion of the blood to flow into passageway means. The passageway means comprises a passageway for the red blood

cells to flow therethrough and is of tapering cross sectional area between a distal end whose cross sectional area is greater than that of a typical red blood cell and a proximal end whose cross sectional area is less than that of a typical red blood cell. Viewing means, e.g., a microscope, is provided to view the red blood cells at different longitudinal positions along the tapering passageway to thereby enable the direct visual determination of their deformability.

Brief Description of the Drawings

Other objects and many of the attendant advantages of this invention will be readily appreciated as the same becomes better understood by reference to the following detailed description when considered in connection with the accompanying drawings wherein:

Fig. 1 is a sectional view, partially schematic, showing one embodiment of the apparatus of this invention and for carrying out one method of this invention;

Fig. 2 is an enlarged sectional view taken along lines 2 - 2 of Fig. 1;

Fig. 3 is an enlarged sectional view taken along lines 3 - 3 of Fig. 1;

Fig. 4 is a view, similar to that of Fig. 1, but showing an alternative embodiment of the apparatus of this invention and for carrying out another method of this invention; and

Fig. 5 is an enlarged view, partially in section, showing a portion of the details of the apparatus shown in Fig. 4.

Detailed Description of The Preferred Embodiment

Referring now in detail to the various figures of the drawing wherein like reference characters refer to like parts, there is shown at 20 in Fig. 1 one embodiment of apparatus constructed in accordance with the subject invention. The apparatus 20 is arranged for withdrawing a sample of the blood of a living being at a controlled rate and determining the deformability of the red blood cells

thereof substantially contemporaneously with the flow of such cells within the being's body, e.g., from a few milliseconds to a few seconds after withdrawal.

The apparatus 20 basically comprises a pair of components, namely, a sampling unit 22, and an associated control/analysis unit 24.

The sampling unit 22 will be described in detail later. Suffice it for now to state that it includes a hypodermic needle arranged to be inserted within a suitable blood vessel 26 of the being to withdraw a sample of blood at a controlled rate and to pass that sample through a constriction while monitoring pressure drops on either side of the constriction to provide electric signals to the control/analysis unit 24. That unit is arranged to be located remote from the sampling unit and utilizes the signals from the sampling unit to calculate the deformability of the red blood cells. In particular the deformability of the red blood cells is readily calculated by the unit 24 using software in it, without requiring manual interaction.

The sampling unit 22 basically comprises a syringe-like body 28 having a hypodermic needle 30 located at its free end. The syringe-like body 28 includes a hollow rear portion 32, formed of any suitable material, e.g., glass, in which a moveable piston 34 is disposed. The front of the body is in the form of a pair of axially aligned tube sections 36 and 38, each of a predetermined inner diameter, e.g., 2 to 3 mm, and length, e.g., 3 cm, and which are connected by a substantially reduced inner diameter capillary tube section 40. The tube section 40 merges into the tube sections 36 and 38 via respective conical sections 42 and 44, respectively, with the total length of the sections 40, 42 and 44 being approximately 4 cm.

The tube section 40 is of constant inner diameter and is smaller than the diameter of a typical red blood cell so that in order for red blood cells to pass therethrough they will have to deform. In accordance with a preferred embodiment of this invention the inner diameter of the

capillary tube section 40 is 5 μm (a typical red blood cell has a diameter of approximately 8 μm). All of the tube sections 36-44 are in fluid communication with each other, with the hypodermic needle 30, and with the interior of the body portion 32.

The needle 30 is arranged to be inserted through the skin of the being into the interior of his/her blood vessel 26, e.g., an artery in the arm, and the apparatus operated (as will be described later) to withdraw blood at a controlled rate from the vessel through the tube sections 36-44. Means are provided associated with the tube sections 36 and 38 to provide signals indicative of pressure drops along predeterminedly spaced sensors located in those tube sections. These signals, coupled with signals indicative of the flow rate of blood through those tube sections (to be described later), are utilized by the control/analysis unit 24 to calculate the deformability of the red blood cells.

As will be appreciated by those skilled in the art if the blood of the being contains deformable red blood cells those cells will be able to freely pass through the capillary tube section 40, whereupon the pressure drop in sections 36 and 38 will be the same. If however, the red blood cells exhibit some non-deformability their passage through the capillary tube section will be impeded by the small diameter of that tube section, whereupon the pressure drop in section 38 will be less than that in section 36. If the red blood cells are non-deformable the pressure drop in section 38 will be significantly less than that in section 36.

The signals indicative of the pressure drops in the tube sections 36 and 38 are provided by two pairs of solid state, e.g., piezoelectric crystal, pressure transducers. In this regard a pair of solid state transducers 46 and 48 are located within the sidewall of the tube section 36 and are flush with the inner surface thereof. A similar pair of transducers 50 and 52 are located within the sidewall of the tube section 38 and are flush with the inner surface thereof.

The transducers 46 and 48 are longitudinally spaced from each other by a fixed, predetermined distance L, e.g., 1.5 cm.

Each transducer 46 and 48 is electrically coupled, via an associated conductor 54, to the control/analysis unit 24 to provide signals indicative of the drop in the pressure of the blood in the distance L between the two transducers. In particular, these signals, are provided to a computer and signal processor 56 forming a portion of the unit 24. In a similar manner the transducers 50 and 52 are longitudinally spaced from each other in the tube section 38 by the same fixed, predetermined distance L and each is electrically coupled, via an associated conductor 58, to the computer and signal processor 56 to provide signals indicative of the drop in the pressure of the blood in the distance L between those two transducers.

The computer and signal processor 56 can be of any suitable construction, e.g., a microprocessor and associated storage means, having software in it to effect the calculation of the red blood cell deformability from the electrical signals provided to via conductors 54 and 58 and from electrical signals indicative of the flow rate of the blood through the tube sections adjacent the transducers.

The rate at which the blood is withdrawn by the apparatus 20 is established by the rate of rearward movement of the piston 34 within the syringe body 32. That rate is established by driver means comprising a driver motor and an associated rack and pinion assembly 60. Signals to control the speed of operation of the drive motor and rack and pinion assembly 60 are provided from a flow rate controller 62. The flow rate controller forms a portion of the control/analysis unit 24. In accordance with a preferred embodiment of this invention the piston 34 can be moved at one of various different speeds in accordance with either manual input signals 64 provided to the controller 62 or by automated signals from the computer and signal processor 56 via lines 66. Those lines also serve to carry signals indicative of

the flow rate (as established by the flow rate controller) to the control/analysis unit.

In Figs. 4 and 5 there is shown an alternative embodiment of apparatus 100 for effecting the determination of the deformability of the red blood cells of the living being. The apparatus 100 differs from apparatus 20 in that apparatus 100 determines deformability by direct visualization of the red blood cells. The apparatus 100 basically comprises a blood sampling unit 102, and an associated visualization system 104. The sampling unit 102 is arranged for withdrawing blood at a controlled rate from a blood vessel 26 of the being to selectively determine the viscosity of a portion of blood withdrawn and to provide another portion of the blood withdrawn to the visualization system 104 where the deformability of its constituent red blood cells are visually examined.

The sampling unit 102 is in the form of an elongated, e.g., 3 cm long, hollow body or tube 106 formed of any suitable material, e.g., stainless steel, and having a constant internal diameter, e.g., 4 mm. A hypodermic needle 108 is mounted on the end of the tube 106 and is in fluid communication with the tube's interior. The sampling unit 102 also includes a two-way, diverter valve 110 which is connected to the tube 104. In particular the valve 110 is mounted so that its common input port 110A is in fluid communication with the interior of the tube 104. The valve 110 includes a pair of output ports. One outlet port 112 is connected to and in fluid communication with a syringe-like member 114 also forming a part of the sampling unit 102.

The other outlet port 116 of the valve 110 is connected to the input to the visualization system 104. That system will be described in detail later. Suffice it for now to state that the visualization system includes a tubular, conically shaped, passageway 118 formed of a transparent material, e.g., glass, and whose internal diameter tapers downward linearly to a size which is smaller than the diameter of a typical red blood cell. In the embodiment

shown herein the passageway tapers from a maximum internal diameter of approximately 20 μm to a minimum internal diameter of approximately 5 μm . The passageway 118 serves as a conduit through which red blood cells are selectively drawn to enable them to be viewed directly as they deform or attempt to deform to pass out of the small end of the passageway.

The apparatus 100, in addition to providing for direct visualization of the deformability of the red blood cells also effects the calculation of the viscosity of the blood portion withdrawn by the apparatus. This data is correlated to the perceived (viewed) deformability to provide very meaningful data regarding the deformability of those cells.

The apparatus 100 includes a pair of piezoelectric crystal pressure transducers 120 and 122 are disposed within respective holes in the sidewall of the tube 106 flush with the inner surface thereof (like the transducers 46 and 48 described with reference to apparatus 20). The transducers 120 and 122 are longitudinally spaced apart by a predetermined distance, L, e.g., 1.5 cm and are connected via respective conductors 124 to a control/analysis unit 24 (like that described heretofore). In particular the conductors 124 are connected to a signal processor 56 to provide signals indicative of the drop in the pressure of the blood in the distance L between the two transducers as blood is withdrawn by the apparatus 100. The computer and signal processor 56 can be of any suitable construction, e.g., a microprocessor and associated storage means, having software in it to effect the calculation of the viscosity from the electrical signals provided to it. Those signals constitute the pressure drop signals provided from the transducers, as well as electrical signals indicative of the flow rate of the blood adjacent the transducers and the other parameters (to be described later). In addition the computer and signal processor 56 provides signals to the valve 110 via lines 126 to control operation of the valve. Signals indicative of the valve's state are

provided via those lines back to the computer and signal processor 56.

The computer and signal processor 56 has stored therein data representing the value of the distance separating the transducers 120 and 122. That data, together with the flow rate Q of the blood (provided via a signal from the flow rate controller 62) enables the computer and signal processor to calculate the viscosity of the blood. In particular the instantaneous blood viscosity, η , is calculated by the computer and signal processor 56 in accordance with the following formula where D is the inner diameter of the tube 106, ΔP is the pressure drop between transducers 120 and 122, L is the distance between the transducers, and Q is the blood volume flow rate:

$$\eta = \frac{\pi D^4 \Delta P}{128 L Q}$$

As can be seen in Fig. 2 the syringe-like unit 114 basically comprises a tubular body 128 in which a piston 130 is located. The piston is similar to that described heretofore with reference to the apparatus 20 and is driven by similar driver means under the control of the flow rate controller 62. Thus, with the diverter valve adjusted to connect its input port to the syringe-like unit 114 and with the hypodermic needle disposed within a suitable blood vessel, e.g., artery, 26 the rearward movement of the piston 134 withdraws some blood from the artery at a controlled rate and causes that blood to pass through the tubular portion 106 of the apparatus where the pressure drop across the transducers is monitored. From those signals the apparatus 100 calculates the viscosity of the withdrawn blood.

The visualization system 104 comprises the heretofore identified tapered passageway 118, red blood cell illuminating means 132, and viewing means 134 (Fig. 5). The illuminating means preferably comprises a conventional laser, e.g., a 10mW green laser, for producing a small diameter, e.g., 20 μm , laser beam 136 and directing that beam through the tapered passageway 118 to illuminate the red blood cells

140 passing through the beam. The viewing means 134 comprises any suitable device such as an optical microscope and/or a video or still camera to enable the illuminated red blood cells to be examined visually and, if desired, recorded on some media, e.g., film, magnetic tape, etc.

In accordance with a preferred embodiment of this invention the passageway 118 is arranged to be shifted longitudinally so that the laser beam 136 can pass through any portion of the tapered passageway 118. Thus, the deformability of the red blood cells can be quickly determined and correlated to the viscosity of the blood withdrawn to provide meaningful information.

Without further elaboration, the forgoing will so fully illustrate my invention that others may, by applying current or future knowledge, readily adopt the same for use under various conditions of service.

CLAIMS

What is claimed is:

1. Apparatus for determining in vivo the deformability of the red blood cells of a living being, said apparatus comprising sampling means arranged to be coupled to a blood vessel of said being for monitoring a portion of the blood of said being at substantially the time that said portion of said blood is flowing through said vessel to determine the deformability of said red blood cells, said sampling means comprising at least one passageway through which said portion of said blood of said being flows therethrough, said sampling means providing information indicative of the deformability of said red blood cells as said portion of said blood flows through said passageway.

2. The apparatus of Claim 1 wherein said apparatus is arranged to maintain the temperature of said blood as it is monitored by said sampling means.

3. The apparatus of Claim 1 wherein said apparatus is arranged to isolate said portion of said blood from the ambient atmosphere.

4. The apparatus of Claim 2 wherein said apparatus is arranged to isolate said portion of said blood from the ambient atmosphere.

5. The apparatus of Claim 1 wherein said information provided by said sampling means is an electrical signal.

6. The apparatus of Claim 2 wherein said information provided by said sampling means is an electrical signal.

7. The apparatus of Claim 3 wherein said information provided by said sampling means is an electrical signal.

8. The apparatus of Claim 4 wherein said information provided by said sampling means is an electrical signal.

9. The apparatus of Claim 1 wherein said sampling means is arranged to withdraw said portion of said blood from said vessel.

10. The apparatus of Claim 5 wherein said sampling means is arranged to withdraw said portion of said blood from said vessel.

11. The apparatus of Claim 6 wherein said sampling means is arranged to withdraw said portion of said blood from said vessel.

12. The apparatus of Claim 7 wherein said sampling means is arranged to withdraw said portion of said blood from said vessel.

13. The apparatus of Claim 8 wherein said sampling means is arranged to withdraw said portion of said blood from said vessel.

14. The apparatus of Claim 9 wherein said sampling means comprises a first passageway for said red blood cells to freely flow therethrough, first means for determining a pressure differential between two longitudinally spaced apart points in said first passageway, restricted passageway means coupled to said first passageway and whose cross sectional area is smaller than that of a typical red blood cell, second passageway means coupled to said restricted passageway means for said red blood cells to freely flow therethrough, second means for determining a pressure differential between two longitudinally spaced apart points in said second passageway, and third means for establishing the flow rate of said portion of said blood flowing through said sampling means adjacent said points.

15. The apparatus of Claim 10 wherein said sampling means comprises a first passageway for said red blood cells to freely flow therethrough, first means for determining a pressure differential between two longitudinally spaced apart points in said first passageway, restricted passageway means coupled to said first passageway and whose cross sectional area is smaller than that of a typical red blood cell, second passageway means coupled to said restricted passageway means for said red blood cells to freely flow therethrough, second means for determining a pressure differential between two longitudinally spaced apart points in said second passageway, and third means for establishing the flow rate of said portion of said blood flowing through said sampling means adjacent said points.

16. The apparatus of Claim 11 wherein said sampling means comprises a first passageway for said red blood cells to freely flow therethrough, first means for determining a pressure differential between two longitudinally spaced apart points in said first passageway, restricted passageway means coupled to said first passageway and whose cross sectional area is smaller than that of a typical red blood cell, second passageway means coupled to said restricted passageway means for said red blood cells to freely flow therethrough, second means for determining a pressure differential between two longitudinally spaced apart points in said second passageway, and third means for establishing the flow rate of said portion of said blood flowing through said sampling means adjacent said points.

17. The apparatus of Claim 12 wherein said sampling means comprises a first passageway for said red blood cells to freely flow therethrough, first means for determining a pressure differential between two longitudinally spaced apart points in said first passageway, restricted passageway means coupled to said first passageway and whose cross sectional area is smaller than that of a typical red blood cell, second passageway means coupled to said restricted passageway means for said red blood cells to freely flow therethrough, second means for determining a pressure differential between two longitudinally spaced apart points in said second passageway, and third means for establishing the flow rate of said portion of said blood flowing through said sampling means adjacent said points.

18. The apparatus of Claim 13 wherein said sampling means comprises a first passageway for said red blood cells to freely flow therethrough, first means for determining a pressure differential between two longitudinally spaced apart points in said first passageway, restricted passageway means coupled to said first passageway and whose cross sectional area is smaller than that of a typical red blood cell, second passageway means coupled to said restricted passageway means for said red blood cells to freely flow therethrough, second means for determining a pressure differential between two longitudinally spaced apart points in said second passageway, and third means for establishing the flow rate of said portion of said blood flowing through said sampling means adjacent said points.

19. The apparatus of Claim 14 wherein each of said first means and second means comprises a pair of solid state transducers.

20. The apparatus of Claim 15 wherein each of said first means and second means comprises a pair of solid state transducers.

21. The apparatus of Claim 16 wherein each of said first means and second means comprises a pair of solid state transducers.

22. The apparatus of Claim 17 wherein each of said first means and second means comprises a pair of solid state transducers.

23. The apparatus of Claim 18 wherein each of said first means and second means comprises a pair of solid state transducers.

24. The apparatus of Claim 9 wherein said sampling means comprises a first passageway for said red blood cells to flow therethrough said first passageway being of tapering cross sectional area and having a distal end whose cross sectional area is greater than that of a typical red blood cell and having a proximal end whose cross sectional area is less than that of a typical red blood cell, and viewing means to view said red blood cells at different longitudinal positions along said first passageway.

25. The apparatus of Claim 24 additionally comprising means for establishing the flow rate of said portion of said blood through said first passageway.

26. The apparatus of Claim 24 wherein said viewing means comprises a microscope.

27. A method of determining in vivo the deformability of red blood cells of a living being comprising the steps of:

- (a) coupling sampling means having a passageway to a blood vessel of said being to permit the monitoring of a portion of the blood of said being flowing through said passageway at substantially the time that said portion of said blood is flowing through said vessel;
- (b) monitoring said portion of said blood flowing through said passageway at said time; and
- (c) determining the deformability of the red blood cells as a result thereof.

28. The method of Claim 27 additionally comprising maintaining the temperature of said blood portion as it is monitored.

29. The method of Claim 27 additionally comprising isolating said portion of said blood from the ambient atmosphere as it is monitored.

30. The method of Claim 28 additionally comprising isolating said portion of said blood from the ambient atmosphere as it is monitored.

31. A method of determining in vivo the deformability of red blood cells in the blood of a living being, said method comprising the steps of:

- (a) extracting a portion of said blood from said being into receiving means, said receiving means comprising a first passageway for said red blood cells to freely flow therethrough, a restricted passageway coupled to said first passageway and whose cross sectional area is smaller than that of a typical red blood cell, and a second passageway coupled to said restricted passageway for said red blood cells to freely flow therethrough;
- (b) causing said portion of blood to flow through said passageways at a controlled rate;
- (c) determining a first pressure differential between two longitudinally spaced apart points in said first passageway;
- (d) determining a second pressure differential between two longitudinally spaced apart points in said second passageway; and
- (e) comparing said first and second pressure differentials to provide an indication of the deformability of said red blood cells.

32. A method of determining in vivo the deformability of red blood cells in the blood of a living being comprising the steps of:

- (a) extracting a portion of said blood from said being into receiving means, said receiving means comprising a first passageway for said red blood cells to flow therethrough said first passageway being of tapering cross sectional area and having an upstream end whose cross sectional area is greater than that of a typical red blood cell and having a downstream end whose cross sectional area is less than that of a typical red blood cell;
- (b) causing said portion of blood to flow through said passageway; and
- (c) viewing said red blood cells at different longitudinal positions along said passageway to provide an indication of the deformability of said red blood cells.

33. The method of Claim 31 additionally comprising the step of maintaining the temperature of said blood portion as it is monitored.

34. The method of Claim 33 additionally comprising the step of isolating said portion of said blood from the ambient atmosphere as it is monitored.

35. The method of Claim 32 additionally comprising the step of maintaining the temperature of said blood portion as it is monitored.

36. The method of claim 35 additionally comprising the step of isolating said portion of said blood from the ambient atmosphere as it is monitored.

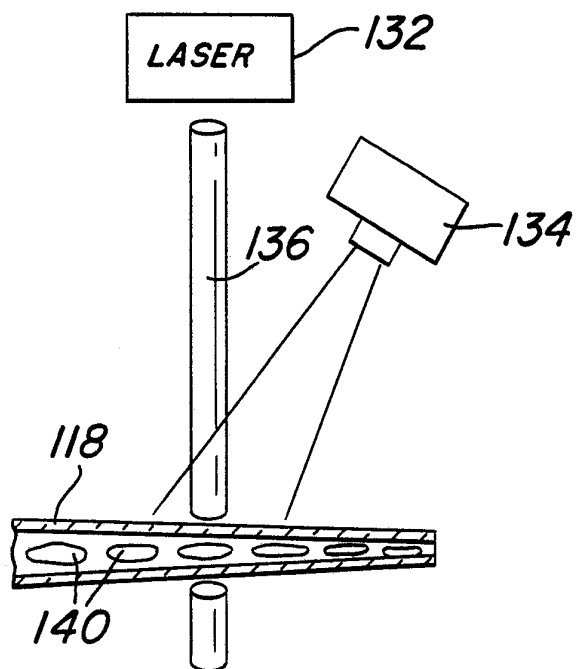
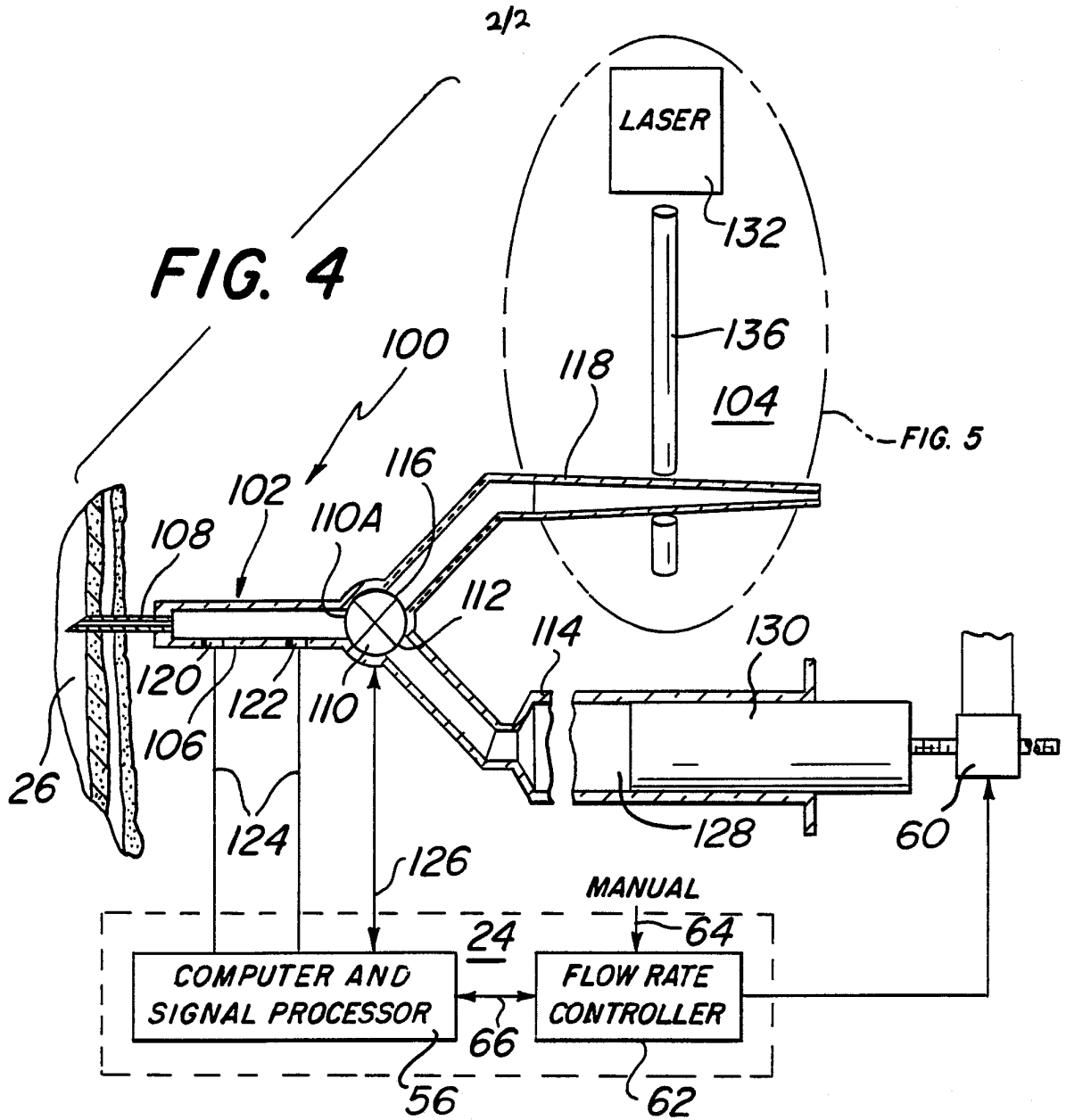

INTERNATIONAL SEARCH REPORT

PCT/US 92/01251

International Application No

I. CLASSIFICATION OF SUBJECT MATTER (if several classification symbols apply, indicate all) ⁶		
According to International Patent Classification (IPC) or to both National Classification and IPC		
Int.Cl. 5 G01N33/49		
II. FIELDS SEARCHED		
Minimum Documentation Searched ⁷		
Classification System	Classification Symbols	
Int.Cl. 5	G01N	
Documentation Searched other than Minimum Documentation to the Extent that such Documents are Included in the Fields Searched ⁸		
III. DOCUMENTS CONSIDERED TO BE RELEVANT⁹		
Category ¹⁰	Citation of Document, ¹¹ with indication, where appropriate, of the relevant passages ¹²	Relevant to Claim No. ¹³
Y	EP,A,0 368 241 (HITACHI, LTD.) 16 May 1990	1-23, 27-31
A	see column 3, line 44 - column 10, line 15; figures	24-26, 32-36

Y	US,A,3 900 290 (HORNSTRA) 19 August 1975	1-23, 27-31
A	see column 1, line 64 - column 2, line 63; figure	24-26, 32-36

P,Y	WO,A,9 113 338 (HATFIELD POLYTECHNIC HIGHER EDUCATION CORPORATION) 5 September 1991	14-23
P,A	see page 6, line 14 - page 11, line 21; figures	1-13, 24-36

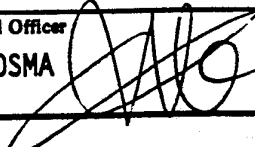
	-/--	
<p>¹⁰ Special categories of cited documents:</p> <p>"A" document defining the general state of the art which is not considered to be of particular relevance</p> <p>"E" earlier document but published on or after the international filing date</p> <p>"L" document which may throw doubts on priority claim(s) or which is cited to establish the publication date of another citation or other special reason (as specified)</p> <p>"O" document referring to an oral disclosure, use, exhibition or other means</p> <p>"P" document published prior to the international filing date but later than the priority date claimed</p> <p>"T" later document published after the international filing date or priority date and not in conflict with the application but cited to understand the principle or theory underlying the invention</p> <p>"X" document of particular relevance; the claimed invention cannot be considered novel or cannot be considered to involve an inventive step</p> <p>"Y" document of particular relevance; the claimed invention cannot be considered to involve an inventive step when the document is combined with one or more other such documents, such combination being obvious to a person skilled in the art.</p> <p>"&" document member of the same patent family</p>		
IV. CERTIFICATION		
Date of the Actual Completion of the International Search	Date of Mailing of this International Search Report	
24 JULY 1992	24. 08. 92	
International Searching Authority	Signature of Authorized Officer	
EUROPEAN PATENT OFFICE	R. A. P. BOSMA 	

III. DOCUMENTS CONSIDERED TO BE RELEVANT (CONTINUED FROM THE SECOND SHEET)		Relevant to Claim No.
Category °	Citation of Document, with indication, where appropriate, of the relevant passages	
A	CLINICAL CHEMISTRY. vol. 26, no. 10, September 1980, WINSTON US pages 1435 - 1442; W. GRONER, ET AL.: 'NEW OPTICAL TECHNIQUE FOR MEASURING ERYTHROCYTE DEFORMABILITY WITH THE EKTACYTOMETER'	1-36
A	--- MEDICAL AND BIOLOGICAL ENGINEERING. vol. 21, no. 3, May 1983, STEVENAGE GB pages 270 - 276; Y. KIKUCHI, ET AL.: 'IMPROVED FILTRATION METHOD FOR RED CELL DEFORMABILITY MEASUREMENT'	1-36
A	--- FR,A,2 345 716 (WEBER AND PETER) 21 October 1977 see page 5, line 4 - page 12, line 36; figures	1-36
A	--- EP,A,0 209 711 (HOECHST AG) 28 January 1987 see page 3, line 10 - page 5, line 14; figures 1,2	1,27,31, 32
A	--- EP,A,0 092 775 (KIESEWETTER) 2 November 1983 see the whole document	1,27,31, 32

**ANNEX TO THE INTERNATIONAL SEARCH REPORT
ON INTERNATIONAL PATENT APPLICATION NO. US 9201251
SA 58509**

This annex lists the patent family members relating to the patent documents cited in the above-mentioned international search report. The members are as contained in the European Patent Office EDP file on The European Patent Office is in no way liable for these particulars which are merely given for the purpose of information. 24/07/92

Patent document cited in search report	Publication date	Patent family member(s)	Publication date
EP-A-0368241	16-05-90	JP-A- 2130471	18-05-90
		US-A- 5023054	11-06-91
US-A-3900290	19-08-75	AT-B- 331420	25-08-76
		CA-A- 1007482	29-03-77
		DE-A- 2410945	19-09-74
		FR-A, B 2221732	11-10-74
		GB-A- 1469151	30-03-77
		JP-A- 50048778	01-05-75
		NL-A- 7303522	17-09-74
		SE-B- 409624	27-08-79
		SE-A- 7403082	22-12-74
WO-A-9113338	05-09-91	AU-A- 7340891	18-09-91
FR-A-2345716	21-10-77	DE-A- 2613212	06-10-77
		DE-A- 2658799	29-06-78
		CH-A- 614046	31-10-79
		GB-A- 1566154	30-04-80
		JP-A- 53004588	17-01-78
		NL-A- 7703231	29-09-77
		SE-A- 7703449	28-09-77
		US-A- 4165632	28-08-79
EP-A-0209711	28-01-87	DE-A- 3522186	02-01-87
		JP-A- 62182654	11-08-87
		US-A- 4797606	10-01-89
EP-A-0092775	02-11-83	DE-A- 3215719	03-11-83
		JP-A- 59015849	26-01-84
		US-A- 4521729	04-06-85