



INTERNATIONAL APPLICATION PUBLISHED UNDER THE PATENT COOPERATION TREATY (PCT)

(51) International Patent Classification⁶ : A61B	A2	(11) International Publication Number: WO 98/11814 (43) International Publication Date: 26 March 1998 (26.03.98)
(21) International Application Number: PCT/US97/16990 (22) International Filing Date: 19 September 1997 (19.09.97) (30) Priority Data: 08/717,492 20 September 1996 (20.09.96) US 08/933,294 18 September 1997 (18.09.97) US (71) Applicant: UNITED STATES SURGICAL CORPORATION [US/US]; 150 Glover Avenue, Norwalk, CT 06856 (US). (72) Inventors: HOLSTEN, Henry, E.; 25 Cedar Avenue, Wolcott, CT 06716 (US). SAVAGE, Robert, C.; 136 Floral Way, Stratford, CT 06497 (US). MARKUS, Richard, L.; 27 Evening Drive, Milford, CT 06460 (US). (74) Agents: BARRESE, Rocco, S. et al.; Dilworth & Barrese, 33 Earle Ovington Boulevard, Uniondale, NY 11553 (US).		(81) Designated States: AU, CA, JP, European patent (AT, BE, CH, DE, DK, ES, FI, FR, GB, GR, IE, IT, LU, MC, NL, PT, SE). Published <i>Without international search report and to be republished upon receipt of that report.</i>
(54) Title: COIL FASTENER APPLIER AND REMOVER		
(57) Abstract <p>There is provided a surgical coil fastener applier for use in applying helical coil fasteners in surgical procedures, such as hernia repair, to affix surgical mesh to tissue. The coil fastener applier includes a housing having a handle extending therefrom and a trigger pivotally mounted on the housing. An elongated tubular portion extends from the housing and includes a drive rod rotatably supported therein and slidably supporting a plurality of coil fasteners thereon. A drive assembly is provided within the housing to rotate the drive rod and coil fasteners. The drive assembly includes an anti-reverse mechanism to allow rotation of the drive rod in only one direction. An actuation assembly is provided within the housing to convert the motion of the trigger into rotary motion for supply to the drive assembly. The drive assembly includes structure to limit the amount of rotary motion supplied to the drive assembly. The drive assembly further includes a ratchet and pawl mechanism to prevent a partial cycling of the coil fastener applier. Also provided are various coil fasteners for use with the coil fastener applier. The surgical coil fastener applier is configured and dimensioned to remove a coil fastener from tissue or drive a fastener previously applied to tissue further into the tissue. A lockout mechanism is provided to immobilize the drive rod relative to the elongated tubular portion.</p>		

FOR THE PURPOSES OF INFORMATION ONLY

Codes used to identify States party to the PCT on the front pages of pamphlets publishing international applications under the PCT.

AL	Albania	ES	Spain	LS	Lesotho	SI	Slovenia
AM	Armenia	FI	Finland	LT	Lithuania	SK	Slovakia
AT	Austria	FR	France	LU	Luxembourg	SN	Senegal
AU	Australia	GA	Gabon	LV	Latvia	SZ	Swaziland
AZ	Azerbaijan	GB	United Kingdom	MC	Monaco	TD	Chad
BA	Bosnia and Herzegovina	GE	Georgia	MD	Republic of Moldova	TG	Togo
BB	Barbados	GH	Ghana	MG	Madagascar	TJ	Tajikistan
BE	Belgium	GN	Guinea	MK	The former Yugoslav Republic of Macedonia	TM	Turkmenistan
BF	Burkina Faso	GR	Greece	ML	Mali	TR	Turkey
BG	Bulgaria	HU	Hungary	MN	Mongolia	TT	Trinidad and Tobago
BJ	Benin	IE	Ireland	MR	Mauritania	UA	Ukraine
BR	Brazil	IL	Israel	MW	Malawi	UG	Uganda
BY	Belarus	IS	Iceland	MX	Mexico	US	United States of America
CA	Canada	IT	Italy	NE	Niger	UZ	Uzbekistan
CF	Central African Republic	JP	Japan	NL	Netherlands	VN	Viet Nam
CG	Congo	KE	Kenya	NO	Norway	YU	Yugoslavia
CH	Switzerland	KG	Kyrgyzstan	NZ	New Zealand	ZW	Zimbabwe
CI	Côte d'Ivoire	KP	Democratic People's Republic of Korea	PL	Poland		
CM	Cameroon	KR	Republic of Korea	PT	Portugal		
CN	China	KZ	Kazakstan	RO	Romania		
CU	Cuba	LC	Saint Lucia	RU	Russian Federation		
CZ	Czech Republic	LI	Liechtenstein	SD	Sudan		
DE	Germany	LK	Sri Lanka	SE	Sweden		
DK	Denmark	LR	Liberia	SG	Singapore		
EE	Estonia						

COIL FASTENER APPLIER AND REMOVER

This application is a continuation-in-part of U.S. Application Serial No. 08/717,492, filed September 20, 1996, entitled Coil Fastener Applier, the disclosure of which is incorporated by reference herein.

BACKGROUND**1. Technical Field**

This disclosure relates generally to surgical apparatus for fastening objects to body tissue and, more particularly, to a coil fastener applier configured to apply helical coil fasteners to surgical mesh and tissue during surgical repair of the body tissue in procedures such as hernia repair and to a surgical apparatus and method of removing the helical coil fasteners from tissue.

2. Background of Related Art

Various surgical procedures require instruments capable of applying fasteners to tissue to form tissue connections or to secure objects to tissue. For example, during hernia repair it is often desirable to fasten a mesh to body tissue. In certain hernias, such as direct or indirect inguinal hernias, a part of the intestine protrudes through a defect in the support abdominal wall to form a hernial sac. The defect may be repaired using an open surgery procedure in which a relatively large incision is made and the hernia is closed off outside the abdominal wall by suturing. The mesh is attached with sutures over the opening to provide reinforcement.

Less invasive surgical procedures are currently available to repair a hernia. In laparoscopic procedures surgery is performed in the abdomen through a small incision while in endoscopic procedures, surgery is performed through narrow endoscopic tubes or cannulas inserted through small incisions in the body. Laparoscopic and endoscopic procedures generally require long and narrow instruments capable of reaching deep within the body and configured to seal with the incision or tube they are inserted through. Additionally, the instruments must be capable of being actuated remotely, that is, from outside the body.

Currently endoscopic techniques for hernia repair utilize fasteners, such as, surgical staples or clips, to secure the mesh to the tissue to provide reinforcement to the repair and structure for encouraging tissue ingrowth. The staples or clips need to be compressed against the tissue and mesh to secure the two together.

5 One other type of fastener suited for use in affixing mesh to tissue, during procedures such as hernia repair, is a coil fastener having a helically coiled body portion terminating in a tissue penetrating tip. An example of this type of fastener is disclosed in U.S. Patent No. 5,258,000.

10 Thus, there exists a need for an improved applier device for applying coil type fasteners to tissue. Since it is often desirable to remove previously positioned or partially inserted coil fasteners from tissue, it would be advantageous if such device enabled removal of the coil type fasteners from tissue if desired. There also exists a need for an applier device which can reengage a coil fastener previously applied to tissue and drive the coil fastener further into the tissue.

15 **SUMMARY**

20 There is provided a surgical coil fastener applier for use in applying coil fasteners to tissue and, in particular, for use in surgical procedures such as hernia repair to affix surgical mesh to tissue. The coil fastener applier includes a housing having a handle extending therefrom and a trigger pivotally mounted on the housing. An elongated tubular portion extends from the housing and includes a drive rod rotatably supported therein. The drive rod is provided to drive the coil fasteners into tissue. The drive rod slidably supports a plurality of coil fasteners thereon and includes a slot to engage tangs of the coil fasteners to rotate the fasteners within a sleeve. Preferably a spring insert is permanently affixed within the sleeve to guide
25 the coil fastener distally as the drive rod is rotated.

A drive assembly is provided within the housing to rotate the drive rod in a first direction. The drive assembly includes intermeshed first and second bevelled gears oriented perpendicular to each other. The first bevelled gear engages

and rotates the drive rod while the second bevelled gear receives rotary motion from an actuation assembly. Preferably, the drive assembly includes an anti-reverse mechanism to allow rotation of the drive rod in only one direction, i.e. the first direction. The anti-reverse mechanism is formed by providing a gap between the
5 second beveled gear and a hub provided to rotate the second beveled gear. A plurality of roller pins are provided within the gap and move between reduced cross-sectional areas of the gap to engage the hub with the second beveled gear and areas of increased cross-sectional areas to release the second beveled gear from the hub. This arrangement forms a roller clutch to prevent rotation of the second beveled gear in an
10 opposite direction thereby preventing reversal of the rotation of the drive rod and withdrawal of a coil fastener partially driven into tissue.

The actuation assembly is provided within the housing to convert the pivotal motion of the trigger into rotary motion for supply to the drive assembly. The actuation assembly generally includes a ratchet-plate gear and an idler gear. The
15 ratchet-plate gear engages the trigger and is rotated thereby. The ratchet-plate gear rotates the idler gear which in turn rotates a gear attached to the hub. The idler gear includes stops which cooperate with a blocking member formed on the housing to limit the degree of rotation imparted to the gear on the hub. This ensures that only one coil fastener at a time is driven from elongated tubular portion during a single
20 cycling or depression of the trigger.

The drive assembly further includes a ratchet and pawl mechanism to prevent a partial cycling of the coil fastener applier. Ratchet teeth on the ratchet-plate gear engage a pawl on the housing preventing return of the trigger to an initial start
25 position before a complete cycle or depression of the trigger has occurred. This prevents a coil fastener from being only partially rotated out of the elongated tubular portion and thus only partially rotated into tissue.

Also provided are coil fasteners for use with the coil fastener applier. In one embodiment the coil fastener is formed with a helical coil body portion having

a single tissue penetrating point at an end thereof. A straight tang is formed at the opposite end of the body portion and extends inwardly across the center of a circle formed by the coils. The tang is provided to engage a slot in the drive rod and allow the coil fastener to be rotated by the drive rod.

5 In an alternate embodiment, the coil fastener is formed with a straight backspan and helical coil body portions extending from each end of the back span. A tissue penetrating point is provided at a free end of each body portion. The backspan engages a slot extending completely through a drive rod and is slidably supported therein. Rotation of the drive rod rotates the coil fastener within the sleeve and into
10 tissue.

 In a further alternative embodiment, the coil fastener is formed with a straight backspan having a straight leg extending from each end of the backspan and which are parallel to each other. A semi-circular tissue penetrating portion terminating in a tissue penetrating point extends from a free end of each leg. The
15 semi-circular tissue penetrating portions are in a common plane which is generally parallel to the backspan. The backspan of the coil fastener also engages a completely slotted drive rod and is rotated thereby.

 There is also provided a surgical coil fastener applier which is configured to remove coil fasteners from tissue. The coil fastener applier has an
20 elongated tubular portion with a coiled spring affixed therein which forms a helical inner surface and which terminates in a distalmost tip. The coil fastener applier is configured to engage a tang of the coil fastener when positioned over a coil fastener. The distal end of the coil fastener applier is dimensioned such that the distance between the distalmost tip of the elongated tubular portion and a distalmost end of a
25 drive rod is at least half the predetermined wire diameter of a coil fastener. In this manner, upon positioning the distal end of the coil fastener applier over a coil fastener positioned in tissue, the tang of the coil fastener will be engaged by a slot in the drive rod. Specifically, the slot in the drive rod engages at least half the diameter of the

tang. Further, the angle between the distalmost tip of the helical surface and the slot when the trigger is in an unfired position is approximately 110°.

5 The coil fastener applier for use in removing coil fasteners further includes a lockout mechanism which is engagable to immobilize the drive rod relative to the tubular portion allowing the entire instrument to be rotated to remove the coil fastener. Preferably, the lockout mechanism includes a lockout button movably mounted on the housing and a blocking member which is movable into engagement of the drive assembly to immobilize the drive rod. The blocking member preferably is a leaf spring affixed within the housing and having a hook engagable with a gear assembly of the drive assembly. The lockout button is provided with a cam to force the hook into engagement with teeth on the gear of the drive assembly.

10 Alternatively, a portion of the trigger may be configured to engage the leaf spring and pivot the leaf spring about a pivot point to engage the hook with the teeth on the drive assembly as the trigger is fully depressed during a firing cycle.

15 There is also disclosed a method of removing a coil fastener from tissue which includes providing a coil fastener applier having an elongated tubular portion with a helical inner surface and a drive rod rotatably mounted within the tubular portion. The drive rod has a slot for engaging the tang and the coil fastener. The method further includes the steps of immobilizing the drive relative to the tubular portion, engaging the coil fastener with the drive rod, and rotating the coil fastener applier to remove the coil fastener from tissue.

20 In another embodiment of a coil fastener applier, a threaded surface is roll formed in an interior surface of the elongated tubular portion. The roll formed threaded surface replaces the coil spring of previous embodiments and serves to thread coil fasteners out of the elongated tubular portion. Additionally, a ratchet plate clutch mechanism is substituted for the roller clutch of previous embodiments.

25 Further, additional structure is provided on the ratchet plate gear to engage and block the second bevelled gear from rotating when the applier is in the unfired position.

BRIEF DESCRIPTION OF THE DRAWINGS

A preferred embodiment of a helical coil fastener applier is described below with reference to the drawings wherein:

5 FIG. 1 is a perspective view of a preferred embodiment of a coil fastener applier;

FIG. 2 is a perspective view of a helical coil fastener utilized with the coil fastener applier of FIG. 1;

FIG. 3 is a perspective view of a distal portion of a drive rod and a helical coil fastener;

10 FIG. 4 is a perspective view of the distal portion of the drive rod with a plurality of helical coil fasteners loaded thereon;

FIG. 5 is a perspective view, with parts separated, of an elongated tubular portion, a spring and the drive rod with a plurality of helical coil fasteners loaded on the distal portion thereof;

15 FIG. 6 is a sectional view of a distal portion of the elongated tubular portion with the spring installed therein;

FIG. 7 is a perspective view of the elongated tubular portion with the drive rod inserted therein;

20 FIG. 8 is a perspective view, with parts separated, of a housing portion of the coil fastener applier of FIG. 1;

FIG. 9 is a perspective view of the housing portion of the coil fastener applier of FIG. 1 with the housing half removed;

FIG. 10 is a perspective view of a housing half illustrating the positioning of the idler gear and the ratchet-plate gear;

25 FIG. 11 is a perspective view of the assembled idler gear and ratchet-plate gear;

FIG. 12 is a sectional view taken along line 12-12 of FIG. 8 and illustrating a roller clutch mechanism;

FIG. 13 is a side view, with a housing half removed, of the housing portion of the coil fastener applier in an initial position;

FIG. 14 is a partial side view, showing the positioning of the idler gear and ratchet-plate gear in an initial position corresponding to FIG. 13;

5 FIG. 15 is a perspective view, partially shown in cross-section, of a distal end portion of the coil fastener applier corresponding to FIG. 13;

FIG. 16 is a view similar to FIG. 13 showing initial actuation of the coil fastener applier;

10 FIG. 17 is a view similar to FIG. 14 and corresponding to the position of FIG. 16;

FIG. 18 is a sectional view of the roller clutch corresponding to FIG. 16;

15 FIG. 19 is a perspective view, partially shown in cross-section, illustrating a helical coil fastener being driven out of the distal end of the coil fastener applier;

FIG. 20 is a side view of the housing portion, with a housing half removed, illustrating initial release of a trigger and positioning of the idler gear and the ratchet-plate gear;

20 FIG. 21 is a sectional view of the roller clutch corresponding to FIG. 20;

FIG. 22 is a partial side view showing the positioning of the idler gear and ratchet-plate gear along with a pawl corresponding to the position of FIG. 20;

FIG. 23 is a view similar to FIG. 22 after complete release of the trigger;

25 FIG. 24 is a perspective view showing the use of the coil fastener applier in the patient;

FIG. 25 is a perspective view of a tissue section and a surgical mesh secured to the tissue section by a plurality of helical coil fasteners;

FIG. 26 is a perspective view of an alternate coil fastener;
FIG. 27 is a perspective view of another alternate coil fastener;
FIG. 28 is an end view of the distal end of an alternate embodiment of a coil fastener applier;

5 FIG. 29 is a sectional view of the distal end of the coil fastener applier of FIG. 28 taken along line 29-29 of FIG. 28;

FIG. 30 is an isolated view of FIG. 29 illustrating the distal end of the elongated tubular portion relative to the distal end of a coiled spring affixed therein;

10 FIG. 31 is a view of the proximal portion of a coil fastener applier of FIG. 28 including a lock mechanism;

FIG. 32 is a partial side view of the embodiment of FIG. 31 with the lock mechanism in an engaged condition;

FIG. 33 is a sectional view of the distal end being advanced toward a coil fastener applied to tissue;

15 FIG. 34 is a view similar to FIG. 33 and illustrating the distal end of the fastener applier engaged with the coil fastener;

FIG. 35 is a perspective view of a patient and rotation of the coil fastener applier to withdraw the coil fastener;

20 FIG. 36 is a sectional view of the distal end of the fastener applier with the coil fastener partially removed from the tissue;

FIG. 37 is a side view of the coil fastener applier of FIG. 31 illustrating an alternate method of engaging the lock mechanism;

FIG. 38 is a perspective view of an alternate embodiment of a coil fastener applier;

25 FIG. 38A is an enlarged perspective view of the distal end of the embodiment of FIG. 38;

FIG. 39 is a perspective view of an elongated tubular portion and a drive rod having a plurality of fasteners supported thereon;

FIG. 40 is a sectional view of a distal end portion of the elongated tubular portion of FIG. 39;

FIG. 41 is a perspective view, with parts separated, of a housing portion of the coil fastener applier of FIG. 38;

5

FIG. 42 is a plan view of a first ratchet plate;

FIG. 43 is a sectional view taken along line 43-43 of FIG. 42;

FIG. 44 is a plan view of a second ratchet plate;

FIG. 45 is a sectional view taken along line 45-45 of FIG. 44;

10

FIG. 46 is a perspective view of a second bevelled gear with a ratchet plate clutch positioned thereon;

FIG. 47 is a perspective view of the ratchet plate clutch including the first and second ratchet plates;

FIG. 48 is a perspective view of an assembled idler gear, ratchet plate gear and trigger gear;

15

FIG. 49 is an end view of the distal end of the coil fastener applier of FIG. 38;

FIG. 50 is a view partially shown in section of the distal end of the coil fastener applier taken along line 50-50 of FIG. 49;

20

FIG. 51 is a view, partially shown in section of the housing portion of the embodiment of FIG. 38 and illustrating an anti-reverse leaf spring engaged with teeth on the second bevelled gear;

FIG. 52 is a view similar to FIG. 51 and showing initial actuation of the embodiment of FIG. 51;

25

FIG. 53 is a side elevational view showing the first and second ratchet plates of the ratchet plate clutch in an engaged condition;

FIG. 54 is a perspective view, partially shown in cross-section, illustrating a helical coil fastener being driven out of the distal end of the coil fastener applier of FIG. 38;

FIG. 55 is a view similar to FIG. 51 illustrating release of a trigger of the housing portion;

FIG. 56 is a side elevational view of the ratchet plate clutch illustrating the first and second ratchet plate in slipping engagement; and

5 FIG. 57 is a partial side view illustrating a stud on the ratchet plate gear engaged in a notch on the second bevelled gear.

DETAILED DESCRIPTION OF PREFERRED EMBODIMENTS

10 With reference now to the drawings wherein like numerals represent like elements throughout the several views and initially with respect to FIG. 1, there is disclosed a preferred embodiment of a coil fastener applier 10. Coil fastener applier 10 is provided to apply helical-shaped coil fasteners to tissue or to secure mesh to tissue during surgical procedures such as hernia repair. Coil fastener applier 10 generally includes a housing 12 which may be formed as two separate housing halves 12a and 12b and a handle portion 14 extending from housing 12. A trigger 15 16 is movably mounted to housing 12. Preferably, trigger 16 is pivotally connected to housing 12 with a free end of trigger 16 spaced from a free end of handle portion 14. This arrangement provides an ergonomic advantage and positive secure control of trigger 16 and coil fastener applier 10. Coil fastener applier 10 also includes an elongated tubular portion 18 extending distally from housing 12. The elongated tubular portion 18 is provided to retain a plurality of coil fasteners for application to 20 body tissue. Elongated tubular portion 18 is preferably dimensioned to fit through conventional cannula structure. As used herein the term "distal" refers to that portion of the applier, or component thereof, further from the user while the term "proximal" refers to that portion of the applier or component thereof, closer to the user.

25 Referring now to FIG. 2, there is illustrated a helical-shaped coil fastener suitable for use with coil fastener applier 10. Coil fastener 20 is designed to be applied to tissue by rotating the coil into and through the tissue. Coil fastener 20

generally includes a coil body portion 22, preferably having approximately 2 1/2 coils and terminating in a sharp tissue penetrating point 24. A tang 26 is provided at an opposite end of coil body portion 22. Tang 26 extends generally inwardly toward the center of coil body portion 22 as shown. Coil fastener 20 is preferably formed of a suitable biocompatible material, such as, for example, titanium. However, coil fastener 20 may alternatively be formed of various elastomeric or polymeric materials and in addition may be formed of various bioabsorbable or biodegradable materials.

Referring now to FIG. 3, a distal portion 28 of a drive rod 30 associated with coil fastener applier 10 is provided to retain and drive coil fasteners 20. Distal portion 28 generally includes a longitudinally extending slot 32 extending along the length of distal portion 28. Slot 32 is provided to receive tang 26 therein such that upon rotation of drive rod 30 coil fastener 20 is similarly rotated. While slot 32 is illustrated as extending partially across drive rod 30, slot 32 may be formed completely through drive rod 30 to accommodate other types of coil or rotatable fasteners. A flat 34 extends adjacent slot 32 in distal portion 28.

As best shown in FIG. 4, a plurality of coil fasteners 20 may be arranged in a series longitudinally along the length of distal portion 28 of drive rod 30. Each coil fastener 20 has its associated tang 26 positioned within slot 32 of drive rod 30.

Referring now to FIG. 5, and as noted above, elongated tubular portion 18 contains a plurality of coil fasteners 20 and structure to drive coil fasteners 20 into tissue. A proximal portion 36 of drive rod 30 is of a generally solid circular cross-section such that slot 32 stops distally of proximal portion 36. A bent or L-shaped proximal end 38 of drive rod 30 is provided to assist in rotating drive rod 30 to advance coil fasteners 20 through elongated tubular portion 18 and drive coil fasteners 20 into tissue. Elongated tubular portion 18 also includes a generally tubular sleeve 40 defining a bore 42 therethrough and having a proximal end 44 and a distal end 46. Drive rod 30 is freely rotatable within bore 42 of tubular sleeve 40.

As best shown in FIGS. 5 and 6, in order to move successive coil fasteners 20 in a distal direction upon rotation of drive rod 30 there is provided a coil spring 48 which is preferably braised or welded to an inner surface 50 of tubular sleeve 40. Coil spring 48 creates a helical longitudinally extending surface 52
5 configured for engagement with the coil body portions 22 of coil fasteners 20. Thus, upon rotation of drive rod 30 coil fasteners 20 are moved along surface 52 and through tubular sleeve 40.

As best seen in FIG. 7, when assembled, L-shaped proximal end 38 of drive rod 30 extends out of proximal end 44 of tubular sleeve 40 for engagement with
10 a drive assembly described hereinbelow.

Referring now to FIGS. 8 and 9, coil fastener applier 10 is provided with a hollow bearing 54 having a port 56 formed in one side thereof. Port 56 is provided to receive proximal end 38 of drive rod 30 in order to rotate drive rod 30 as bearing 54 is rotated. Hollow bearing 54 additionally includes a keyed opening 58
15 formed in a proximal face thereof. A first bevelled gear 62 is provided to rotate bearing 54 and generally includes a plurality of teeth 64 and a shaft 66 extending distally from teeth 64. First bevelled gear 62 includes a keyed distal end 68 which is configured to securely engage the keyed opening 58 in hollow bearing 54. Thus, upon rotation of first bevelled gear 62 drive rod 30 is rotated. As best seen in FIG.
20 8, first beveled gear 62 is oriented perpendicular to, and rotates about, a longitudinal axis x of elongated tubular portion 18. A hollow sleeve 70 is provided having a flange 72 which engages slots 74 in housing halves 12a and 12b. Sleeve 70 rotatably supports first bevelled gear 62 within housing 12.

First bevelled gear 62 forms a part of a drive assembly 76 provided to
25 rotate drive rod 30 in a single direction. Drive assembly 76 additionally includes a second bevelled gear 78 having a plurality of teeth 80 configured to engage teeth 64 of first bevelled gear 62. As shown, first bevelled gear 62 is oriented perpendicularly to second bevelled gear 78. Thus, second bevelled gear 78 rotates in a plane parallel

to longitudinal axis x. Second bevelled gear 78 is rotatably supported within housing 12 by means of a hub 82. A shaft 84 is secured within a bore 88 of hub 82. Shaft 84 includes a keyed end 86. A drive gear 90 is provided to rotate the drive assembly 76 and includes a keyed opening 92 for engagement with keyed end 86 of shaft 84. Drive gear 90 includes a plurality of teeth 94.

Coil fastener applier 10 additionally includes an actuation assembly 96 which, in combination with drive assembly 76, convert longitudinal motion of trigger 16 into rotary motion of drive rod 30. Actuation assembly 96 generally includes a ratchet-plate gear 98 and an idler gear 100, which are rotatably supported on a stud 102 formed in housing half 12a. A compression spring 104 is provided between ratchet-plate gear 98 and idler gear 100 in a manner described in more detail hereinbelow. A pair of trigger gears 106 are affixed to ratchet-plate gear 98 on either side thereof. It should be noted that trigger gears 106 as well as ratchet-plate gear 98, idler gear 100 and drive gear 90 all rotate in planes parallel to that of second bevelled gear 62 and thus of longitudinal axis x of elongated tubular portion 18.

As noted hereinabove, trigger 16 is movably mounted on housing 12. Trigger 16 is pivotably mounted about a stud 108 formed in housing halves 12a and 12b. Trigger 16 is provided with a pair of spaced apart gear portions 110 each having a plurality of teeth 112 which cooperate to engage and rotate teeth 114 on trigger gears 106. Thus, by pivoting trigger 16 about stud 108, gear portions 110 rotate trigger gears 106 and thus ratchet-plate gear 98 and idler gear 100. As shown, idler gear 100 includes a plurality of teeth 116 on an edge thereof. Teeth 116 are configured for engagement with drive gear 90 such that upon actuation of trigger 16 idler gear 100 is rotated to cause rotation of drive gear 90 and thus of drive rod 30. A return spring 118 is provided to bias trigger 16 into an initial position spaced apart from handle 14. Return spring 118 is affixed at one end to a stud 120 on housing half 12a and is affixed at an opposite end to a stud 122 on trigger 16.

Actuation assembly 96 additionally includes a ratchet and pawl mechanism which prevents return of trigger 16 to an initial position until trigger 16 has been fully depressed. Ratchet teeth 124 are preferably formed along an edge of ratchet-plate gear 98. A pawl 126 is pivotally mounted about a stud 128 on housing half 12a and is engageable with ratchet teeth 124. Further, a biasing spring 130 is provided to bias pawl 126 into engagement with ratchet teeth 124. Biasing spring 130 is mounted about a stud 132 on housing half 12a and generally includes a first end 134 configured to engage pawl 126 and a second end 136 which is affixed within a slot 138 formed in housing 12a.

Referring now to FIG. 10, structure is provided to prevent more than one coil fastener 20 from being driven out of coil fastener applier 10 upon a single pull of trigger 16. Housing half 12b includes a blocking member 140 fixedly mounted to housing half 12b. Blocking member 140 is configured to engage first and second stops 142 and 144, respectively, formed on idler gear 100. Second stop 144 limits the degree of rotation of idler gear 100 during actuation of coil fastener applier 10 to install a coil fastener 20 and first stop 142 limits the rotation of idler gear 100 upon release of trigger 16 enabling coil fastener applier 20 to return to an initial position ready to install another coil fastener 20. By providing first and second stops 142 and 144 and blocking member 140, the operator can be assured that drive rod 30 will be rotated a predetermined number of times and that only a single coil fastener 20 will be driven from coil fastener applier 10 at a single time.

Turning now to FIGS. 10 and 11, ratchet-plate gear 98 is formed with a slot 146 which is configured to receive a compression spring 104 in a first portion 150 of slot 146. Compression spring 104 allows a slight amount of rotational movement to occur between ratchet-plate gear 98 and idler gear 100 during actuation and release of trigger 16 in a manner described in more detail hereinbelow. Idler gear 100 is formed with an engagement tab 152 projecting from a side thereof. Engagement tab 152 is positionable within a second portion 154 of slot 146. A first

edge 156 of engagement tab 152 directly engages an edge 148 of ratchet-plate gear 98 while a second edge 158 of engagement tab 152 engages compression spring 104.

5 Referring now to FIG. 12, coil fastener applier 10 includes an anti-reverse mechanism which provides for a free return of hub 82 independent of second bevelled gear 78. This allows hub 82 to rotate second bevelled gear 78 in a driving or first direction when hub 82 is rotated in the first direction to thereby drive coil fastener 20 from coil fastener applier 10. The anti-reverse mechanism disengages hub 82 from second bevelled gear 78 when hub 82 is rotated in a second direction. This is desirable so as to prevent rotation of drive rod 30 in a direction opposite that of its driving direction which would rotate coil fastener 20 such that coil fastener 20 is withdrawn from tissue or mesh or is further withdrawn within tubular portion 18. The anti-reverse mechanism is a roller clutch which is formed between hub 82 and second bevelled gear 78. A plurality of roller pins 160 are provided in a circumferential space or gap 162 defined between hub 82 and second bevelled gear 78. Gap 162 includes enlarged release areas 164 and reduced grasping areas 166. Thus, as hub 82 is rotated in a first direction to move roller pins 160 into the grasping areas 166, roller pins 160 are cammed within grasping areas 166 to form a solid connection between hub 82 and second bevelled gear 78. Alternatively, when hub 82 is rotated in the opposite or second direction, it moves roller pins 160 into enlarged release areas 164 allowing hub 82 to rotate freely and independently of second bevelled gear 78.

15 The operation of coil fastener applier 10 will now be described. Referring initially to FIG. 13, in an initial or starting position, trigger 16 is biased away from handle 14 due to the force of return spring 118. As shown, teeth 112 of trigger 16 are engaged with teeth 114 of trigger gears 106. Ratchet-plate gear 98 is in a counterclockwise most position, as viewed in FIG. 13, and pawl 126 is disengaged from teeth 124 of ratchet-plate gear 98. As best shown in FIG. 14, in the initial or starting position, blocking member 140 is engaged with first stop 142. In

this position, with ratchet-plate gear in its counterclockwise most position and blocking member 140 engaged with first stop 142 of idler gear 100, engagement tab 152 is not engaged with edge 148 of ratchet-plate gear 98 but rather provides a slight compression to compression spring 104 as shown.

5 Referring to FIG. 15, within distal end 46 of tubular sleeve 40, a plurality of coil fasteners 20 are slidably mounted about drive rod 30 and positioned within tubular sleeve 40. Each coil body portion 22 of each coil fastener 20 engages surface 52 of coil spring 48 which, as noted above, is firmly secured to inner surface 50 of tubular sleeve 40.

10 Referring now to FIG. 16, to actuate coil fastener applicator 10, trigger 16 is drawn toward handle 14 against the bias of return spring 118. As trigger 16 is moved, teeth 112 on gear portions 110 of trigger 16 engage and rotate teeth 114 of trigger gears 106 clockwise as seen in FIG. 16. As shown in FIGS. 16 and 17, rotation of trigger gears 106, rotates ratchet-plate gear 98 such that first edge 156 of engagement tab 152 engages ratchet-plate gear 98. Idler gear 100 thus rotates with ratchet-plate gear 98 allowing a short expansion of compression spring 104. As idler gear 100 is rotated in a clockwise direction, as viewed in FIG. 16, teeth 116 of idler gear 100 engaged and rotate drive gear teeth 94 of drive gear 90 counterclockwise.

15 Referring now for the moment to FIG. 18, as drive gear 90 and thus hub 82, are rotated in a counterclockwise direction, the rotation of hub 82 causes roller pins 160 to be forced into the reduced grasping areas 166 of gap 162. Once moved into grasping areas 166, roller pins 160 form a solid and secure connection between hub 82 and second bevelled gear 78. Thus, second bevelled gear 78 is rotated in a counterclockwise direction as shown in FIGS. 16 and 18. Referring now again to FIG. 16, upon rotation of second bevelled gear 78 in a counterclockwise direction, teeth 80 of second bevelled gear 78 engage teeth 64 of first bevelled gear 62 to thereby rotate drive rod 30 within tubular sleeve 40.

Referring now to FIG. 19, as drive rod 30 is rotated within tubular sleeve 40, drive rod 30 rotates coil fasteners 20. Coil fasteners 20, being engaged with surface 52 of coil spring 48, are moved distally within tubular sleeve 40 by engagement of coil body portions 22 with surface 52. Thus, rotation of drive rod 30 rotates or screws a coil fastener out of the distal end of elongated tubular portion 18. As shown, this rotation of drive rod 30 also moves a next successive coil fastener 20 into position to be applied to tissue during a next cycling of coil fastener applier 10.

Referring back to FIG. 16, it should be noted that upon a complete depression of trigger 16, drive rod 30 is rotated precisely a predetermined amount such that only one coil fastener 20 is driven out of the distal end of elongated tubular portion 18. During compression of trigger 16, pawl 126 engages and rides over teeth 124 of ratchet-plate gear 98. Should handle 16 be stopped during depression at any intermediate position, pawl 126 is engaged with teeth 124 to ensure that ratchet-plate gear 98 and idler gear 100 are not rotated in an opposite direction thereby preventing only partial insertion or withdrawal of coil fastener 20, i.e. preventing a partial drive cycle. As shown in FIG. 16, upon complete depression of trigger 16, pawl 126 passes over teeth 124 and is disengaged therefrom.

Referring to FIG. 17, upon a complete depression of trigger 16, idler gear 100 rotates between a position wherein first stop 142 is rotated away from blocking member 140 until a position where blocking member 140 engages second stop 144 to thereby prevent further rotation of idler gear 100. This degree of rotation of idler gear 100 corresponds exactly to the amount of rotation of drive rod 30 necessary to completely drive a single coil fastener 20 out of elongated tubular portion 18 and into tissue.

Referring now to FIG. 20, once trigger 16 had been completely depressed and a coil fastener 20 has been driven from elongated tubular portion 18 into tissue mesh or other suitable structure, trigger 16 may be released. Trigger 16 is then biased to an open or initial position due to the force of return spring 118. As

trigger 16 is moved to an open position, teeth 112 of gear portions 110 rotate teeth 114 of trigger gears 106 counterclockwise, as viewed in FIG. 20, and thus ratchet-plate gear 98 in a counterclockwise direction. As ratchet-plate gear 98 is rotated in a counterclockwise direction, compression spring 104 forces idler gear 100 also in a counterclockwise direction. With idler gear 100 rotating in a counterclockwise direction, teeth 116 of idler gear 100 rotate drive gear 90 in a clockwise direction.

Referring now for the moment to FIG. 21, as noted hereinabove, coil fastener applier 10 includes an anti-reverse mechanism or roller clutch which disengages drive rod 30 from rotation upon release of trigger 16 and allows a free return of drive gear 90 to a start position. Thus, upon clockwise rotation of hub 82, hub 82 moves roller pins 160 into the enlarged release areas 164. Since clutch pins 160 no longer form a solid firm contact between hub 82 and second bevelled gear 78, hub 82 is free to rotate independently of second bevelled gear 78 thereby preventing any rotation of drive rod 30.

Referring to FIGS. 20 and 22 and 23, during release of trigger 16, pawl 126 moves along teeth 124 of ratchet-plate gear 98 until pawl 126 rests on a last tooth 168. This corresponds with the engagement of blocking member 140 with first stop 142 to thereby prevent any further rotation of idler gear 100. Once pawl 126 has reached its position on last tooth 168, the tension of return spring 118, being greater than the force of compression spring 104, forces trigger 16 a little further allowing trigger gears 106 to move ratchet-plate gear 98 slightly against the force of compression spring 104. As best shown in FIG. 23, the force of return spring 118 overcomes the force of compression spring 104 forcing engagement tab 152 to compress return spring 104. This compression of return spring 118 allows ratchet-plate gear 98 to move slightly enabling pawl 126 to move off of last tooth 168 of ratchet-plate gear 98. Thus, coil fastener apparatus 10 is returned to initial position ready to be actuated again and install another coil fastener.

Referring now to FIG. 24, coil fastener applier 10 is shown positioned through a small incision A made in a patient B for use in a surgical procedure, such as, for example, hernia repair.

5 Referring now to FIG. 25, when used for hernia repair, surgical coil fastener applier 10 may be utilized to affix a portion of a suture mesh 170 to a tissue section 172. As shown in FIG. 25, several coil fasteners 20 may be utilized to secure mesh 170 to tissue 172. Preferably, in applying coil fasteners 20, coil fasteners 20 are rotated through mesh 170 and tissue 172 such that only approximately 180° of coil body portion 22 along with tang 26 extend externally of the mesh 170. 10 Tang 26 provides an anchoring or securing mechanism to prevent mesh 170 from sliding off of coil body portion 22 of coil fastener 20.

Referring now to FIGS. 26 and 27, there are disclosed alternate embodiments of coil fasteners suitable for use with coil fastener applier 10. Referring first to FIG. 26, an alternate embodiment coil fastener 174 is formed with a straight 15 backspan 176 and helical coil body portions 178, 180 extending from each end of back span 176. Tissue penetrating points 182, 184 is provided at a free end of respective body portions 178, 180. Backspan 176 engages a slot extending completely through a drive rod (not shown) and is slidably supported thereon. Rotation of the drive rod rotates coil fastener 174 within sleeve 40 of coil fastener applier 10 and into 20 tissue.

Referring now to FIG. 27, in a further alternative embodiment, a coil fastener 186 is formed with a straight backspan 188 having straight legs 190, 192 extending from each end of backspan 188 and which are parallel to each other. Semi-circular tissue penetrating portions 194, 196 terminating in tissue penetrating points 25 198, 199 extend from a free end of respective leg 190, 192. Semi-circular tissue penetrating portions 194, 196 are located in a common plane which is generally parallel to backspan 188. The backspan of the coil fastener also engages a completely slotted drive rod (not shown) and is rotated thereby.

Referring now to FIGS. 28-37, there is disclosed an alternate embodiment of a coil fastener applier. Coil fastener applier 200, as described herein is substantially structurally and functionally identical to that described hereinabove including all the components included therein and can be used in exactly the same fashion to apply coil fasteners to tissue. Coil fastener applier 200 however includes additional structure, in the form of a locking mechanism, such that a drive rod 202 may be immobilized with respect to a tubular sleeve 204 thereby allowing coil fastener applier 200 to engage and remove a coil fastener, such as coil fastener 20, from tissue. Moreover, the design and dimensions of coil fastener applier 200 are such that elongated tubular portion 206 may be positioned over a coil fastener 20 which has been applied to tissue and engage a tang 26 of coil fastener 20 with a slot 208 in drive rod 202. The entire coil fastener applier 200 may then be rotated to remove coil fastener 20 from tissue.

Referring to FIGS. 28-30, a distal end 210 of tubular sleeve 204 terminates in a distalmost edge 212. As with coil fastener applier 10 above, a coil spring 214 is braised or welded to form a helical surface 216 within bore 218 of tubular sleeve 204. Coil spring 214 includes a distal end 220 which terminates in a distal tip 222. Distal end 220 has a flat ground surface 224 which sections or reduces the diameter of tip 222. Drive rod 202 terminates in a distal face 226. As shown in FIG. 28, slot 208 forms an angle of approximately 110° with distal tip 222 of coil spring 214. This angle allows the coil fastener to rotate three full turns in order to be released from coiled spring 214.

As illustrated in FIG. 29, in order to enable a tang 26 of a coil fastener 20 to enter slot 208, the distance "d" between distalmost edge 212 of tubular sleeve 204 and distal face 226 of drive rod 202 must be at least the wire diameter of a surgical fastener 20.

Preferably, this distance "d" is approximately 0.030 inches and at least approximately 0.025 inches depending on the particular coil fastener being used. The

distance between distal face 226 of drive rod 202 and distalmost edge 212 of tubular sleeve 204 in combination with the 110° angle between distal tip 222 and slot 208 of drive rod 202 (FIG. 28) enables slot 208 and drive rod 202 to engage at least half of the wire diameter of a tang 26 as elongated tubular portion 206 is positioned about a coil fastener 20 (FIG. 33) previously applied in tissue. FIGS. 29 and 30 illustrate a second coil fastener 20b positioned within elongated tubular portion 206 such that a tang 26b engages slot 208. A point 24b of second coil fastener 206 is in an initial position prior to actuation of coil fastener applier 200 and remote from distal face 226 of drive rod 202.

As noted above, in order to utilize coil fastener applier 200 to remove a coil fastener 20 from tissue, it is preferable to immobilize drive rod 202 relative to tubular sleeve 204. This can be accomplished by blocking the drive assembly, and, in particular, second bevelled gear 230, against movement thereby preventing rotation of drive rod 202 (FIG. 31).

Referring now to FIGS. 31 and 32, coil fastener applier 200 may be provided with a housing 232 containing a slot 234 in which a lockout button 236 is slidably mounted. Lockout button 236 is provided to immobilize drive rod 202 and, additionally, may serve as a shipping interlock to prevent actuation of coil fastener applier 200 prior to desired use. Lockout button 236 includes a finger surface 238 projecting outwardly away from housing 232. Lockout button 236 also includes cam 240 projecting into housing 232.

A blocking member or leaf spring 242 is provided and is affixed at its proximal end 244 to housing 232. A hook 246 may be provided at a distal end 248 of leaf spring 242 and is configured to engage teeth 250 of second bevelled gear 230. When hook 246 engages teeth 250, second bevelled gear 230, and thus drive rod 202, is prevented from rotation. In order to move hook 246 into engagement with teeth 250, a pivot 252 is rotatably mounted about a pivot pin 254 provided on housing 232. As shown in FIG. 31, in a proximalmost position, lockout button 236 and thus cam

240 does not engage leaf spring 242. Referring to FIG. 32, as lockout button 236 is moved in a distal direction, cam 240 drives hook 246 on distal end 248 into engagement with teeth 250 on second bevelled gear 230 thereby immobilizing drive rod 202. Additionally, hook 246 may be moved into engagement with teeth 250 by a complete firing of trigger 256 as described hereinbelow.

Referring now to FIGS. 32-36, use of coil fastener applier 200 to remove a coil fastener 20 which had previously been imbedded in tissue will now be described. Initially, lockout button 236 is moved distally to engage hook 246 with teeth 250 thereby immobilizing drive rod 202 (FIG. 32). Elongated tubular portion 206 is advanced toward a coil fastener 20a previously positioned in a tissue T and tubular sleeve 204 is positioned about coil fastener 20a such that a tang 26a of coil fastener 20a is positioned within slot 208 in drive rod 202. (See FIGS. 33 and 34).

Referring now to FIGS. 35 and 36, the entire coil fastener applier 200 may be rotated to drive coil fastener 20 further into tissue T or to withdraw coil fastener 20 from tissue T. Coil fastener applier 200 is rotated to rotate elongated tubular portion 206 and thus drive rod 202, simultaneously with tubular sleeve 204, to withdraw coil fastener 20a from tissue T. In this manner, coil fastener applier 200 is uniquely configured and dimensioned to re-engage a tang 26a of coil fastener 20a previously applied to tissue and rotate coil fastener 20a out of tissue.

FIG. 37 illustrates an alternative method of engaging hook 246 with teeth 250 on second bevelled gear 230 is shown. Specifically, lockout button 236 is in a proximalmost or free to fire position. Once trigger 256 has been pulled to a full firing stroke, idler gear 258 engages a proximal portion 260 of leaf spring 242 thereby pivoting leaf spring 242 about pivot 252. As leaf spring 242 is pivoted about pivot 252, hook 246 is driven into engagement with teeth 250 on second bevelled gear 230. Thus, at the end of any individual firing stroke, drive rod 202 is immobilized with respect to tubular sleeve 204 and the entire instrument 200 may be rotated to either further advance or retract a coil fastener 20 with respect to tissue.

Alternatively, trigger 256 may be released to an initial position to begin a second firing stroke.

Referring now to FIGS. 38 to 57, there is disclosed an alternate embodiment of a coil fastener applier. Coil fastener applier 300, as described herein, is substantially structurally and functionally identical to the embodiments described hereinabove. Any structural or functional variations therefrom are described in detail hereinbelow.

Referring initially to FIG. 38, coil fastener applier 300 generally includes a housing 302 which may be formed as separate halves and a handle portion 304 extending from housing 302. A trigger 306 is movably mounted to housing 302. An elongated tubular portion 308 extends distally from housing 302.

Referring to FIG. 38A, elongated tubular portion 308 includes threads 314 therein to facilitate rotating coil fasteners out of elongated tubular portion 308.

Referring now to FIG. 39, elongated tubular portion 308 includes a drive rod 316 rotatably mounted therein. Drive rod 316 supports a plurality of coil fasteners, such as, for example, coil fasteners 20 described hereinabove. As shown in FIG. 40, and in contrast to previous embodiments, threads 314 are integrally formed in an inner surface 318 of elongated tubular portion 308. Threads 314 may be formed within elongated tubular portion 308 by known machining or die stamping methods and are preferably formed by roll-forming threads 314 into elongated tubular portion 308. Threads 314 do not extend completely to distal end 312 of elongated tubular portion 308.

Referring now to FIG. 41, as noted hereinabove, coil fastener applier 300 is substantially structurally identical to previous embodiments. Thus, coil fastener applier 300 is provided with trigger 306 pivotally mounted to housing 302. A spring 320 is provided between trigger 306 and handle 304. Trigger 306 includes gear portions 322 which are configured to engage and rotate a trigger gear 324 mounted to a ratchet plate gear 326. An idler gear 328 is also provided. A spring

330 is positioned between ratchet plate gear 326 and idler gear 328. Ratchet plate gear 326 differs from ratchet plate gears above in a manner described in more detail below. Idler gear 328 is engageable with a drive gear 332 to rotate a second bevelled gear 334. Drive gear 332 is mounted on a shaft 336. In a variation from previous
5 embodiments, the roller-type clutch is replaced with a ratchet plate clutch 338. Ratchet plate clutch 338, including a first ratchet plate 340, a second ratchet plate 342 and a spring 344, is provided to engage and disengage drive gear 332 from second bevelled gear 334 as described hereinbelow.

10 Second bevelled gear 334 drives a first beveled gear 346. Rotation of first bevelled gear 346 rotates a hollow sleeve 348 and a hollow bearing 350 and thus drive rod 316 in a manner substantially identical to that described hereinabove with respect to previous embodiments. As with previous embodiments first and second bevelled gears, 340 and 334, form part of a drive assembly 352 while idler gear 328 and ratchet plate gear 326 form part of an actuation assembly 354.

15 Housing 302 additionally includes a pawl 356 engagable with ratchet plate gear 326. Pawl 356 is biased toward ratchet plate gear 326 by a spring 358. A leaf spring 360 may optionally be provided to engage second bevelled gear 334.

20 Notably, coil fastener applier 300 includes an anti-reverse mechanism for second bevelled gear 334 which differs from that provided on previous embodiments. A blocking spring 362 is mounted to housing 302 and is configured to engage teeth 364 on second bevelled gear 334. Blocking spring 362 allows rotation of second bevelled gear 334 in a first direction to drive coil fasteners from elongated tubular portion 308 while blocking second bevelled gear 334 from rotating in a second and opposite direction.

25 Turning now to FIGS. 42-47, the details of ratchet plate clutch 338 including first and second ratchet plates 340 and 342, respectively, will now be described. Referring to FIGS. 42 and 43 first ratchet plate 340 is formed as a cylinder having an outer surface 366 which is dimensioned and configured to firmly

5 seat within a bore 368 of second bevelled gear 334 (FIG. 41). First ratchet plate 340 defines a bore 370 within which shaft 336 is received. First ratchet plate 340 freely rotates about shaft 336. In order to engage second ratchet plate 342 and thereby alternately fixedly and releasably engage second bevelled gear 334 with shaft 336, first ratchet plate 340 is provided with four equally spaced ratchet teeth 370 on an end face 372 thereof. Ratchet teeth 370 are preferably spaced 90° apart and extend across end face 372 from bore 386 radially outwardly toward outer surface 366. Each of ratchet teeth 370 includes a block portion 374 having an engagement face 376 and an angled surface 378 which slopes from block portion 374 to end face 372. Ratchet teeth 370 cooperate with corresponding teeth on second ratchet plate 342 to alternately fixedly and releasably engage first ratchet plate 340 with second ratchet plate 342.

10 Referring now to FIGS. 44 and 45, second ratchet plate 342 defines a bore 380 which is configured to fixedly receive shaft 336. Specifically, bore 380 includes a keyed or flat surface 382 which engages a corresponding keyed or flat surface 384 on shaft 336 (FIG. 46). Second ratchet plate 342 includes a cylinder 386 and a larger diameter portion 388. Larger diameter portion 388 provides an abutment surface against which spring 344 can bias second ratchet plate 342 toward first ratchet plate 340. Ratchet teeth 390 are provided on an end face 392 of larger diameter portion 388. Ratchet teeth 390 are similar and complimentary to ratchet teeth 370 on first end plate 340. Specifically, each of ratchet teeth 390 includes a block portion 392 having an engagement face 394 and an angled surface 396.

15 FIG. 46 illustrates first ratchet plate 340 positioned within second bevelled gear 334 and shaft 336 positioned within second ratchet plate 342. Second bevelled gear 334 includes two notches 398 for receipt of blocking structure formed on ratchet plate gear 326 as described hereinbelow.

20 Referring to FIG. 47, ratchet teeth 370 on first ratchet plate 340 are configured to fixedly engage ratchet teeth 390 on second bevelled gear 342 when second bevelled gear 342 is rotated in a first direction corresponding to actuation of

coil fastener applier 300. Ratchet teeth 370 sidlingly or releasably engage ratchet teeth 390 when second ratchet plate 342 is rotated in a second and opposite direction corresponding to release and return of trigger 306 after firing coil fastener applier 300. Specifically, engagement faces 376 fixedly engage engagement faces 394 when
5 second ratchet plate 342 is rotated in the first direction and angled surface 378 slide over or releasably engage angled surfaces 396 when second ratchet plate 342 is rotated in the second direction. While constrained to rotate with shaft 336, second ratchet plate 342 is free to slide along the length of shaft 336 against the bias of spring 344 when rotated in the second direction.

10 As noted above, blocking structure is provided on ratchet plate gear 326 to engage notches 396 on second bevelled gear 334. Referring now to FIG. 48, ratchet plate gear 326 includes a stud 400 which engages one of notches 396 when coil fastener applier 300 is in an unfired condition.

15 As with the previous embodiment, coil fastener applier 300 is designed such that elongated tubular portion 308 may be positioned over a coil fastener 20 which has been applied to tissue and engage a tang 26 of coil fastener 20 with a slot 402 in drive rod 316 (FIG. 49). The entire coil fastener applier 300 may then be rotated to remove coil fastener applier 20 from tissue. Additionally, coil fastener applier 300 is designed to engage tang 26 of coil fastener 20 previously applied to
20 tissue and drive coil fastener 20 further into the tissue.

Referring now to FIG. 49, distal end 312 of elongated tubular portion 308 terminates in a distalmost edge 404. Threads surface or threads 314 are roll formed into elongated tubular portion 308 and terminate in a distal tip 406. Drive rod 316 terminates in a distal face 408. As shown, slot 402 forms an angle β with distal tip 406 of thread 314. In order to ensure a sufficient grip on tang 26 of coil fastener 20 previously applied to tissue β is approximately 110° .
25

Referring to FIG. 50, in order to enable tang 26 of coil fastener 20 to enter sot 402 of drive rod 316, the distance d_2 between distalmost edge 404 of

5 elongated tubular portion 308 and distal face 408 of drive rod 316 is approximately 0.030 inches and at least 0.025 inches depending upon the wire diameter of coil fastener 20. As shown, threads 314 end proximally of distal face 408 of drive rod 316. As noted above, the specific combination of β and d_2 enables slot 402 in drive rod 316 to engage tang 26 of a coil fastener 20 previously applied to tissue and withdraw or drive in further coil fastener 20 as coil fastener applier 300 is rotated.

10 The operation of the coil fastener applier 300 to eject a coil fastener 20 therefrom will now be described. Referring to FIG. 51, in an initial and unfired position, stud 400 is positioned within notch 398 of second bevelled gear 334 thereby preventing inadvertent rotation of drive rod 316. Additionally, blocking spring 362 engages teeth 364 of second bevelled gear 334 thereby preventing rotation of second bevelled gear 334 in a second direction. Turning now to FIG. 52, as trigger 306 is depressed towards handle 304, trigger gear portion 322 drives trigger gear 324 and thus ratchet plate gear 326 in a manner similar to that described hereinabove. Stud 15 400 is rotated out of engagement of notch 398 in second bevelled gear 334. As second bevelled gear 334 rotates in the first direction, blocking spring 362 rides over teeth 364. Rotation of idler gear 328 rotates drive gear 332 similar to that described hereinabove and thus rotates shaft 336.

20 Referring now to FIG. 53, the operation of ratchet plate clutch 338 will now be described. Second ratchet plate 342, which is constrained to rotate with shaft 336, is biased against first ratchet plate 340 by spring 344. Thus, engagement face 394 of second ratchet plate 342 engages engagement face 376 of first ratchet plate 340 causing first ratchet plate 340 to rotate with second ratchet plate 342. First ratchet plate 340 rotates second bevelled gear 334 therewith. Rotation of second bevelled gear 25 334 in a first direction rotates drive rod 316 in a manner similar to that described hereinabove with respect to previous embodiments to eject a coil fastener 20.

Referring now to FIG. 54, as drive rod 316 is rotated, a coil fastener 20 is threaded out of distal end of elongated tubular portion 308 by engagement with

threads 314. In this manner, coil fastener applier may be actuated to drive a coil fastener 20 into tissue and/or through hernia mesh and into tissue.

Referring now to FIG. 55, upon release of trigger 306, trigger 306 is biased away from handle 304 by means of spring 320. Release of trigger 306 causes ratchet plate gear 326 to rotate such that stud 400 advances towards notch 398 in second bevelled gear 334. Notably, second bevelled gear 334 is prevented from rotation by engagement of blocking spring 362 with teeth 364 on second bevelled gear 334. Rotation of idler gear 328 rotates drive gear 332 and thus, drive shaft 336.

Referring now to FIG. 56, as drive shaft 336 is rotated in a second direction, it causes rotation of second ratchet plate 342 in a second direction. Rotation of ratchet plate 342 in a second direction causes engagement of angled surface 396 of second ratchet plate 342 with angled surface 378 of first ratchet plate 340. As second bevelled gear 334 is constrained from rotation by means of blocking spring 362 (FIG. 55), second ratchet plate 342 moves longitudinally with respect to shaft 336 and against the bias of spring 344.

Upon complete release of trigger 306, stud 400 re-engages notch 398 in second bevelled gear 334 to there again secure second bevelled gear 334 against rotation (FIG. 57).

As noted hereinabove, at this point, the entire coil fastener applier 300 may be rotated to further drive a coil fastener 20 deeper into tissue or may be utilized to re-engage a tang 26 of coil fastener 20 previously applied and remove coil fastener 20 from tissue. When coil fastener 20 are removed from tissue, an accessory instrument such as, for example, grasping instrumentation may be utilized to remove the unthreaded coil fastener from the surgical site.

It will be understood that various modifications may be made to the embodiments disclosed herein. For example, a shorter elongated tubular portion containing more or less coil fasteners may be provided for greater ease of handling during open surgery. Various articulations may be provided along the length of the

5

elongated tubular portion to facilitate positioning of the coil fastener applier within the body. Additionally various configurations of the drive rod and slots or fastener retaining structure may be provided to accommodate various types of rotary fasteners. Further, alternate mechanisms may be provided to immobilize the drive rod relative to the elongated tubular portion or housing. Therefore, the above description should not be construed as limiting, but merely as exemplifications of preferred embodiments. Those skilled in the art will envision other modifications within the scope and spirit of the claims appended hereto.

WHAT IS CLAIMED IS:

- 5 1. A coil fastener applier comprising:
 a housing having a stationary handle affixed to the housing;
 an elongated tubular portion extending distally from the housing;
 a drive rod rotatably mounted within the elongated tubular portion and
 having at least one coil fastener releasably mounted on the drive rod;
 a drive assembly including a plurality of gears, at least one of the
 gears engageable with the drive rod for rotating the drive rod, the drive assembly
 including an anti-reverse mechanism;
10 an actuation assembly engageable with the drive assembly; and
 a trigger movably mounted on the housing and engageable with the
 actuator assembly, wherein movement of the trigger in a first direction rotates the
 drive rod to drive a coil fastener into tissue, and movement of the trigger in a second
 direction causes the anti-reverse mechanism to disable the actuation assembly from
15 rotating the drive rod.
2. The coil fastener applier of Claim 1, wherein the interior of the
 elongated tubular portion contains a surface which engages a body portion of the at
 least one coil fastener, the surface forcing the at least coil fastener distally as the
 drive rod is rotated in the first direction.
- 20 3. The coil fastener applier of Claim 1, wherein the drive rod extends
 through a center of the at least one coil fastener.
4. The coil fastener applier of Claim 3, wherein the drive rod includes
 a slot for receipt of a tang portion of a coil fastener.

5. The coil fastener applier of Claim 1, wherein the drive assembly includes a first bevelled gear attached to the drive rod and a second bevelled gear engageable with the first bevelled gear and oriented perpendicularly to the first bevelled gear.

5 6. The coil fastener applier of Claim 5, wherein the anti-reverse mechanism includes a plurality of roller pins positioned within a gap defined between the second bevelled gear and a hub, the roller pins engaging the second bevelled gear with the hub when the roller pins are in a reduced area of the gap and releasing the second bevelled gear from engagement with the hub when the roller pins are moved
10 into enlarged areas of the gap.

7. The coil fastener applier of Claim 1, wherein a plurality of coil fasteners are releasably mounted on the drive rod.

8. The coil fastener applier as recited in Claim 6, wherein the drive assembly includes a drive gear affixed to the hub and engageable with the actuation
15 assembly.

9. The coil fastener applier of Claim 1, further comprising a return spring affixed at one end to the housing and at an opposed end to the trigger.

20 10. A coil fastener applier comprising:
a housing having a stationary handle;
a trigger pivotably mounted to the housing;
an elongated tubular portion extending from the housing;
a drive rod rotatably mounted within the elongated tubular portion, the drive rod slidably supporting a plurality of coil fasteners such that rotation of the

drive rod within the elongated tubular portion moves the plurality of coil fasteners toward a distal end of the elongated tubular portion;

a drive assembly rotatably mounted within the housing and engageable with the drive rod to rotate the drive rod;

5 an actuation assembly having an idler gear engageable with the drive assembly and a ratchet-plate gear engageable with the trigger, the idler gear being operatively associated with the ratchet-plate gear.

10 11. The coil fastener applier of Claim 10, wherein the idler gear is rotatably mounted with respect to the housing, the idler gear including first and second stops engageable with a blocking member formed on the housing such that the degree of rotation of the idler gear is limited to that amount necessary to drive a single coil fastener out of the elongated tubular portion.

15 12. The coil fastener applier of Claim 10, wherein the ratchet-plate gear defines a slot and the idler gear includes a tab projecting therefrom and engageable with an edge of the slot.

13. The coil fastener applier of Claim 12, further comprising a compression spring positioned within the slot, the compression spring urging the tab into engagement with the edge of the slot.

20 14. The coil fastener applier of Claim 12, further comprising a pawl mounted on the housing and engageable with ratchet teeth formed on the ratchet-plate gear.

15. The coil fastener applier of Claim 10, wherein the ratchet-plate gear includes a trigger gear having teeth engageable with teeth formed on the trigger,

such that pivoting the trigger with respect to the housing rotates the ratchet-plate gear within a plane parallel to the longitudinal axis of the drive rod.

5 16. The coil fastener applier of Claim 15, wherein the drive assembly includes a first gear rotatable in the plane of the ratchet-plate gear and engageable therewith and a second gear rotatable about the longitudinal axis of the drive rod and affixed thereto, the first gear and second gear being engaged with each other.

10 17. The coil fastener applier of Claim 10, wherein each coil fastener of the plurality of coil fastener includes a coil body portion slidably mounted about the drive rod and terminating in a tissue penetrating tip at one end, the coil body portion including a tang at an opposite end, the tang engageable with a slot formed in the drive rod.

18. A coil fastener applier comprising:

a housing;

15 an elongated tubular portion extending distally from the housing, the elongated tubular portion having a threaded inner surface terminating in a distalmost tip;

20 a drive rod rotatably mounted within the elongated tubular portion and having at least one coil fastener releasably mounted on the drive rod, the at least one coil fastener having a predetermined cross section, the cross section having a width diameter;

a drive assembly for rotating the drive rod;

an actuation assembly engagable with the drive assembly; and

25 a trigger movably mounted on the housing and engageable with the actuator assembly to drive the at least one coil fastener from the elongated tubular portion upon movement of the trigger relative to the housing;

wherein the distance between a distalmost tip of the drive rod and the distalmost tip of the elongated tubular portion is at least equal to half the predetermined width of the at least one coil fastener.

5 19. The coil fastener applier as recited in Claim 18, wherein a tang of the at least one coil fastener is retained within a slot in the drive rod, the angle between the distalmost tip of the threaded surface and the slot when the trigger is in an unfired position is approximately 110°.

10 20. The coil fastener applier as recited in Claim 18, further comprising a lockout mechanism engagable with the drive assembly to immobilize the drive rod relative to the elongated tubular portion.

21. The coil fastener applier as recited in Claim 20, wherein the lockout mechanism includes a lockout button movably mounted on the housing and a blocking member movable into engagement with the drive assembly in response to movement of the lockout button.

15 22. The coil fastener applier as recited in Claim 21, wherein the blocking member is a leaf spring affixed at a first end to the housing and having a second end engagable with the drive assembly.

20 23. The coil fastener as recited in Claim 22, wherein the lockout button includes a cam engagable with the leaf spring to drive the second end into engagement with the drive assembly in response to movement of the lockout button.

24. The apparatus as recited in Claim 23, wherein the second end of the leaf spring includes a hook engagable with teeth on a gear of the drive assembly.

25. The coil fastener applier as recited in Claim 20, wherein the lockout mechanism includes a blocking member movable into engagement with the drive assembly in response to movement of the trigger.

5 26. The coil fastener applier as recited in Claim 25, wherein the blocking member pivots about a pivot point in response to movement of the trigger.

27. A method of removing a coil fastener having a tang from tissue comprising the steps of:

10 a) providing a coil fastener applier having an elongated tubular portion with a threaded inner surface and a drive rod rotatably mounted within the tubular portion, the drive rod having a slot for engaging a tang of a coil fastener previously applied to tissue;

b) immobilizing the drive rod relative to the tubular portion;

c) engaging the coil fastener with the drive rod; and

15 d) rotating the coil fastener applier to remove the coil fastener from the tissue.

28. The method according to Claim 27, wherein the step of engaging includes engaging a tang of the coil fastener within a slot formed in the drive rod.

29. A coil fastener applier comprising:

a housing;

20 an elongated tubular portion extending distally from the housing, the elongated tubular portion having a threaded inner surface terminating in a distalmost tip;

a drive rod rotatably mounted within the elongated tubular portion and having at least one coil fastener releasably mounted on the drive rod, the at least one coil fastener having a predetermined diameter;

a drive assembly for rotating the drive rod;

5 an actuation assembly engagable with the drive assembly;

a trigger movably mounted on the housing and engagable with the actuator assembly to drive the at least one coil fastener from the elongated tubular portion upon movement of the trigger relative to the housing; and

10 means for grasping a tang of an at least one coil fastener positioned in tissue.

30. The coil fastener applier as recited in Claim 29, wherein the means for grasping includes the distance between a distalmost end of the drive rod and a distalmost end of the elongated tubular portion, the distance being approximately 0.03 inches.

15 31. The coil fastener applier as recited in Claim 29, wherein means for grasping includes the angle between a slot in the drive rod and the distalmost tip of the threaded inner surface, the angle being approximately 110°.

32. A method of driving a coil fastener having a tang previously applied to tissue further into tissue comprising the steps of:

20 a) providing a coil fastener applier having an elongated tubular portion with a threaded inner surface and a drive rod rotatably mounted within the tubular portion, the drive rod having a slot for engaging a tang of a coil fastener previously applied to tissue;

b) engaging the coil fastener with the drive rod; and

c) rotating the coil fastener applier to drive the coil fastener further into the tissue.

33. The method according to Claim 27, wherein the step of engaging includes engaging a tang of the coil fastener within a slot formed in the drive rod.

- 5 34. A coil fastener applier comprising:
- a housing;
 - an elongated tubular portion extending distally from the housing, the elongated tubular portion having a threaded inner surface terminating in a distalmost tip;
 - 10 a drive rod rotatably mounted within the elongated tubular portion and having at least one coil fastener releasably mounted on the drive rod, the at least one coil fastener having a predetermined diameter;
 - a drive assembly for rotating the drive rod;
 - an actuation assembly engagable with the drive assembly;
 - 15 a trigger movably mounted on the housing and engagable with the actuator assembly to drive the at least one coil fastener from the elongated tubular portion upon movement of the trigger relative to the housing;
 - means for grasping a tang of an at least one coil fastener positioned in tissue; and
 - 20 means for grasping is includes the distance between a distalmost end of the drive rod and a distalmost end of the elongated tubular portion, the distance being approximately 0.03 inches.

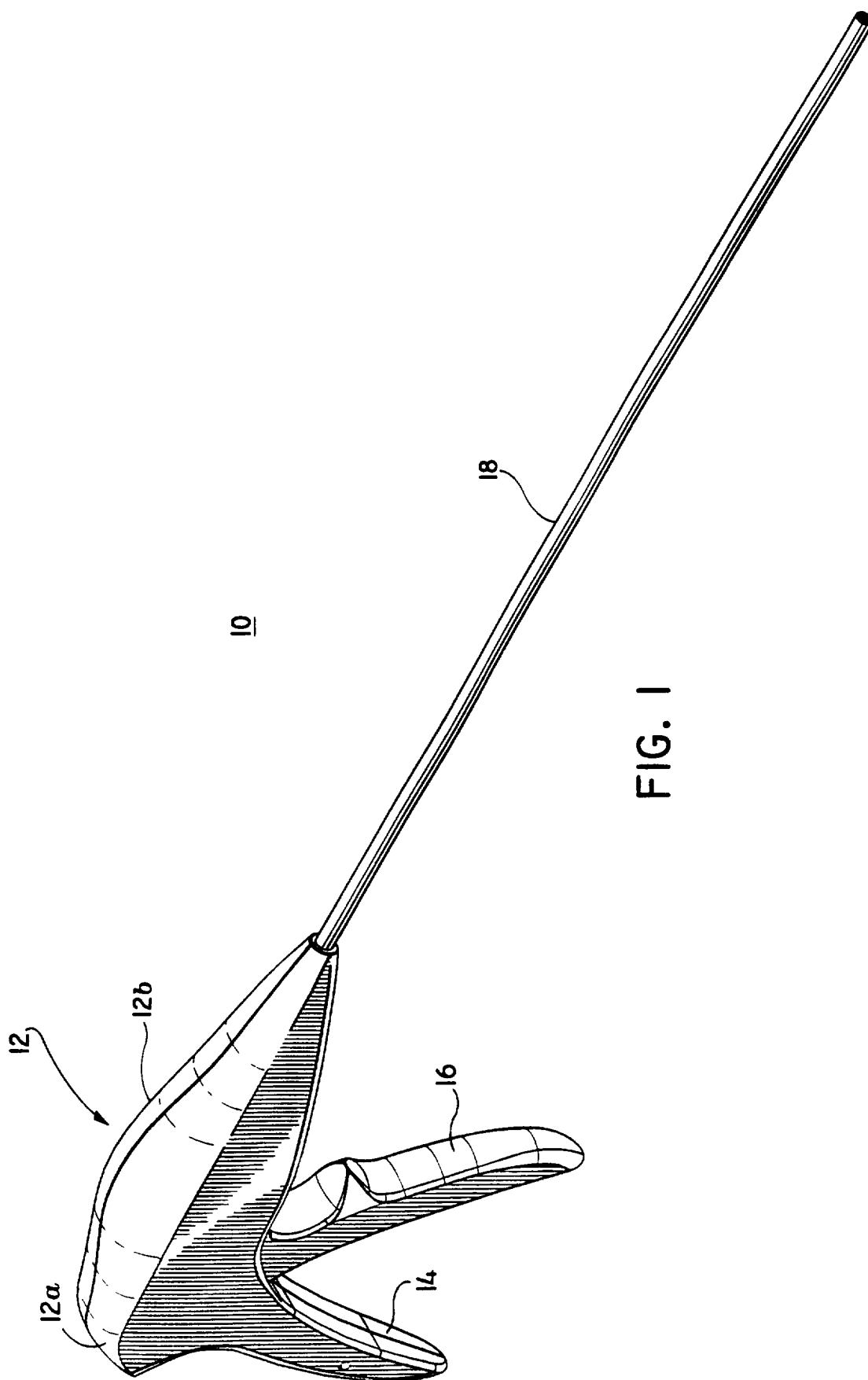

FIG. 1

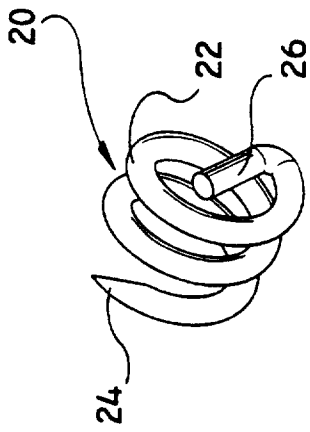

FIG. 2

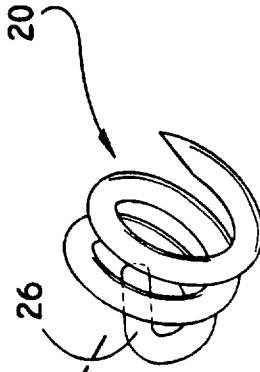

FIG. 3

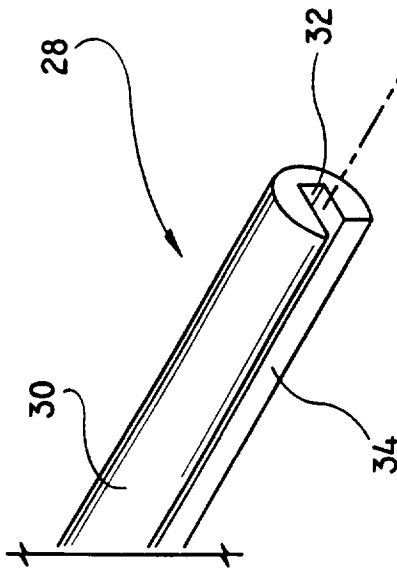
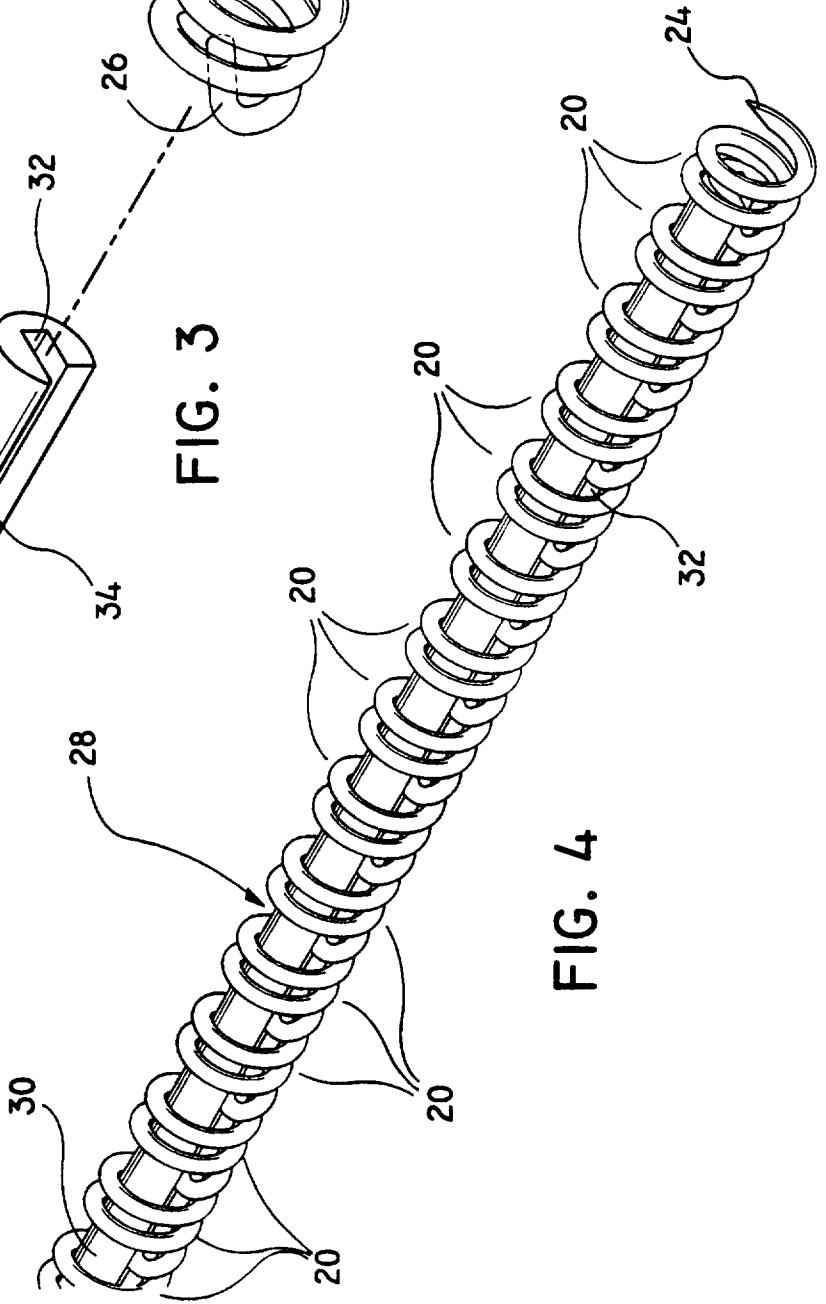
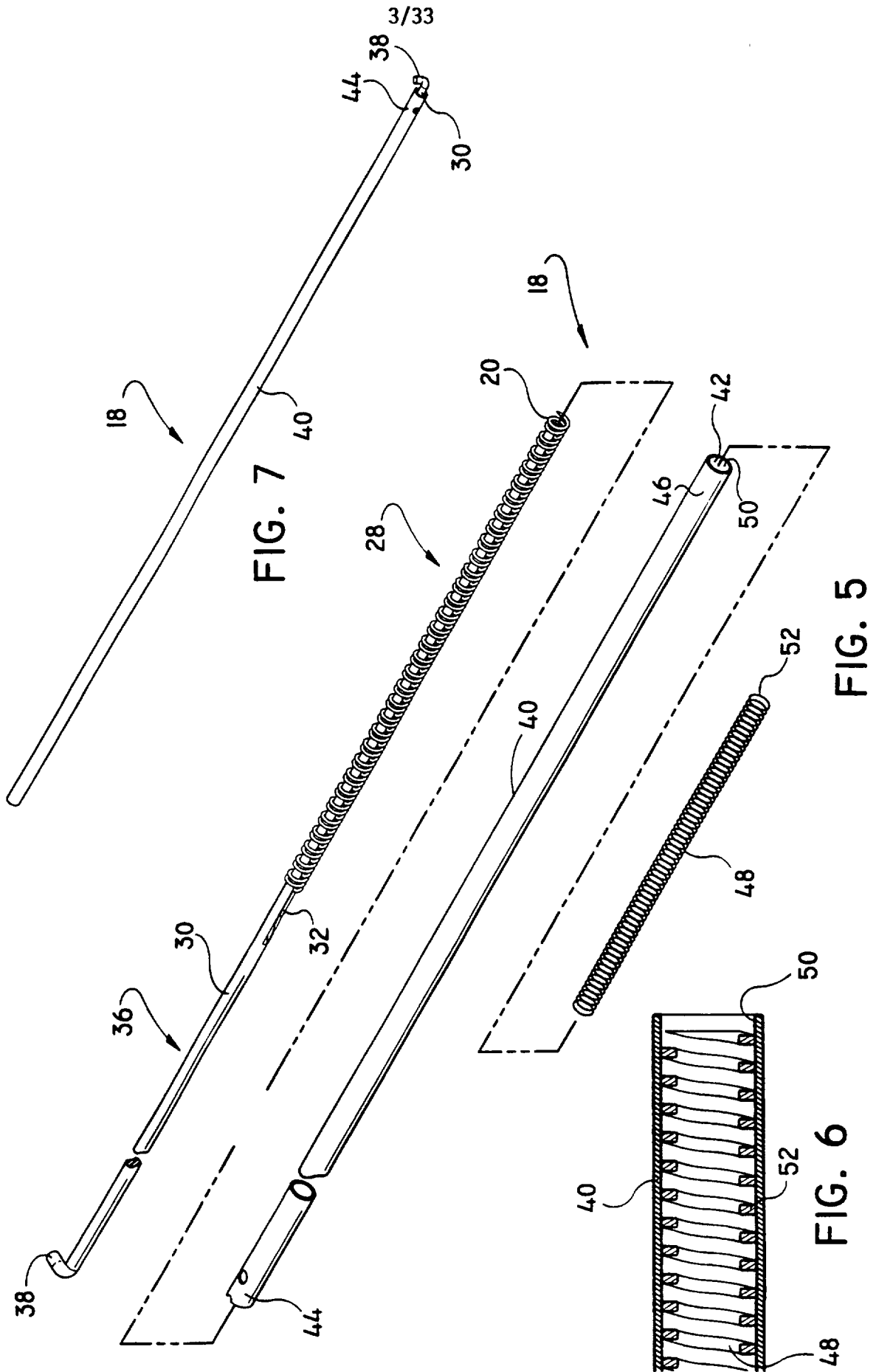

FIG. 4





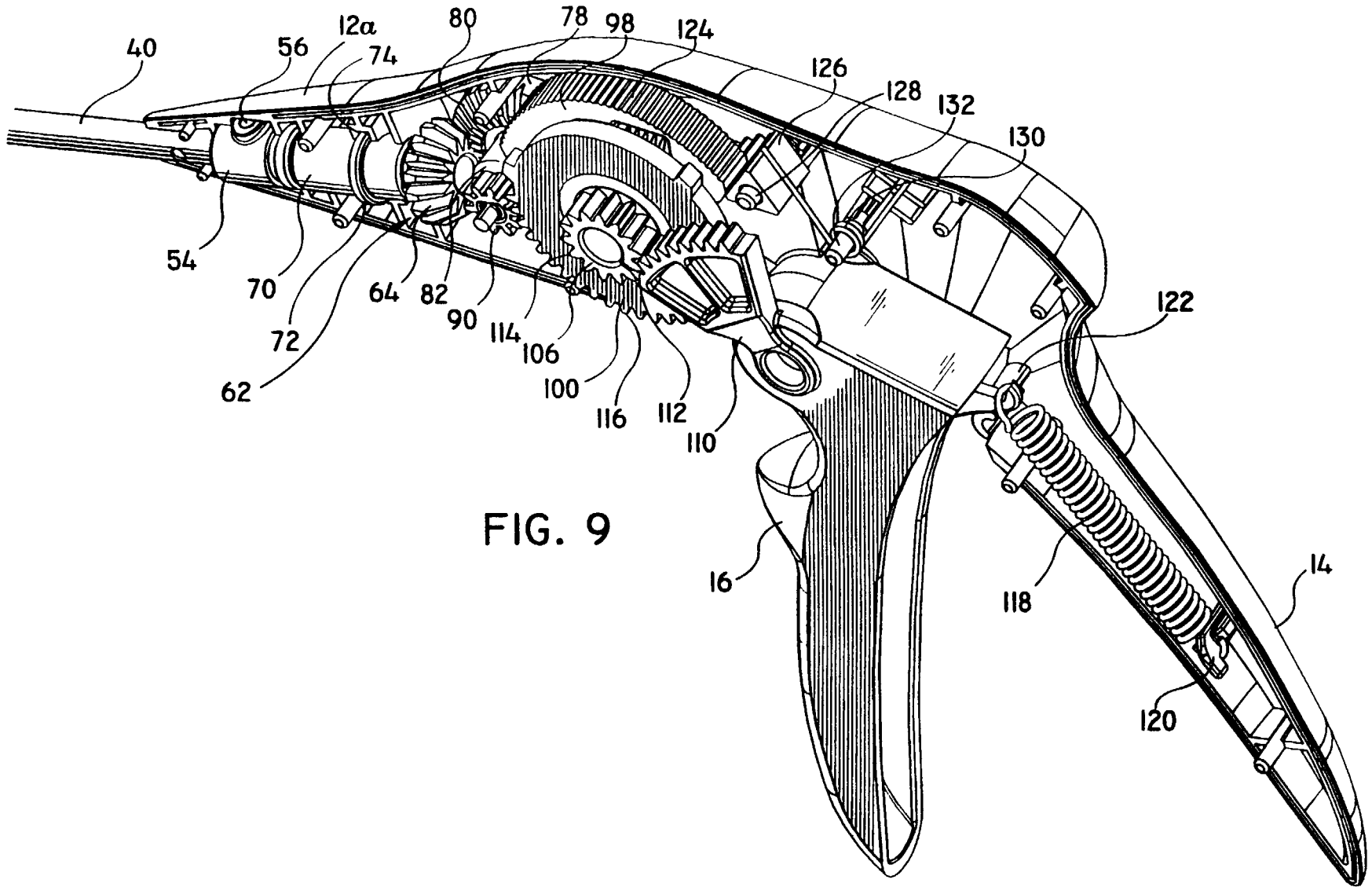

FIG. 9

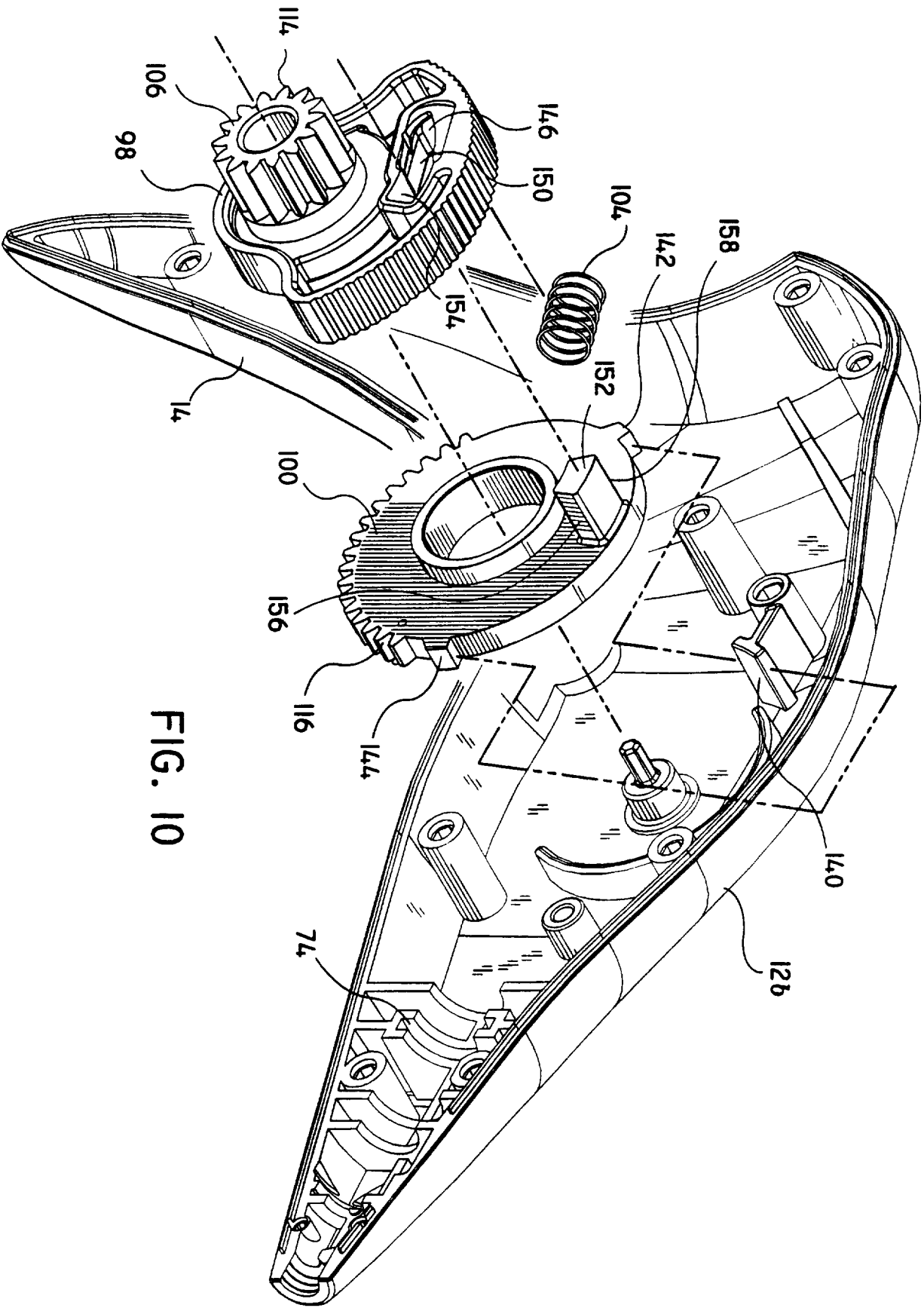

FIG. 10

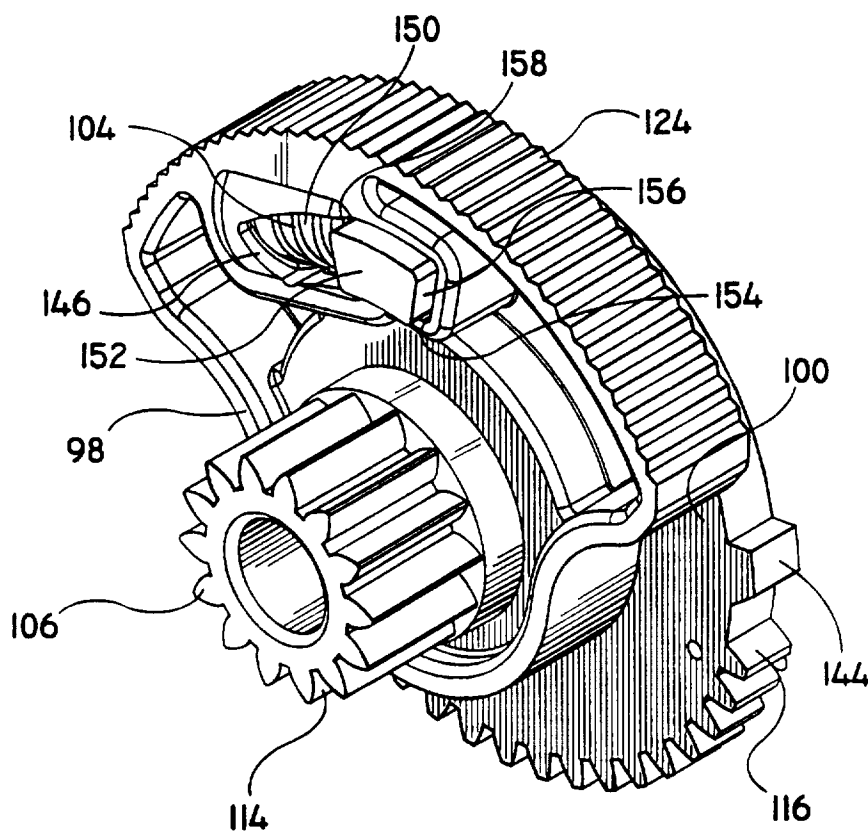

FIG. II

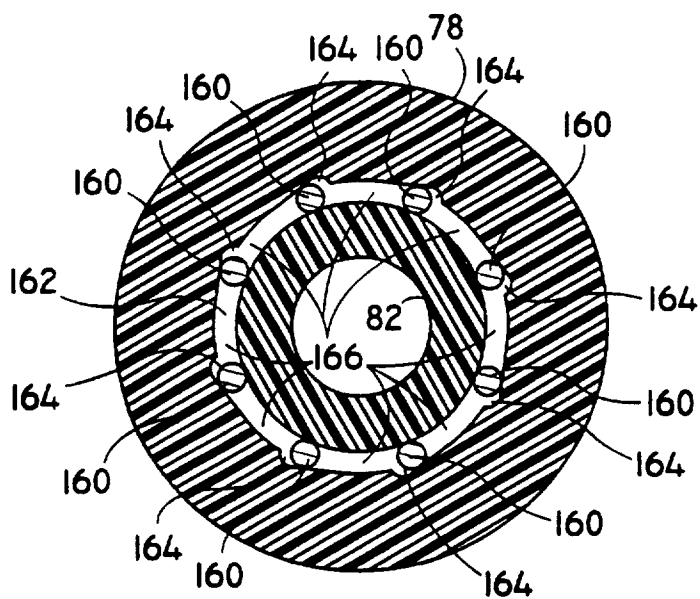
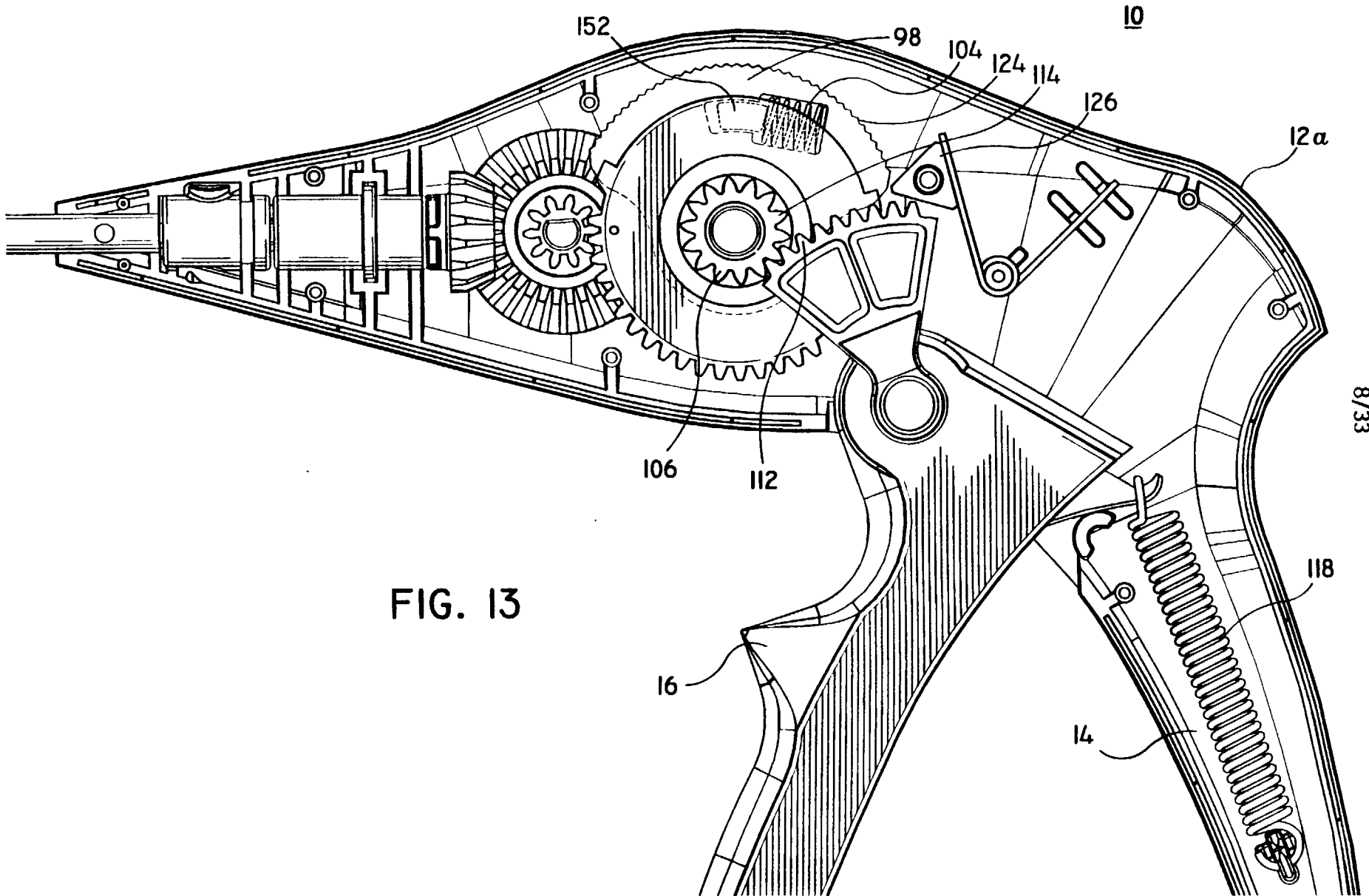

FIG. 12



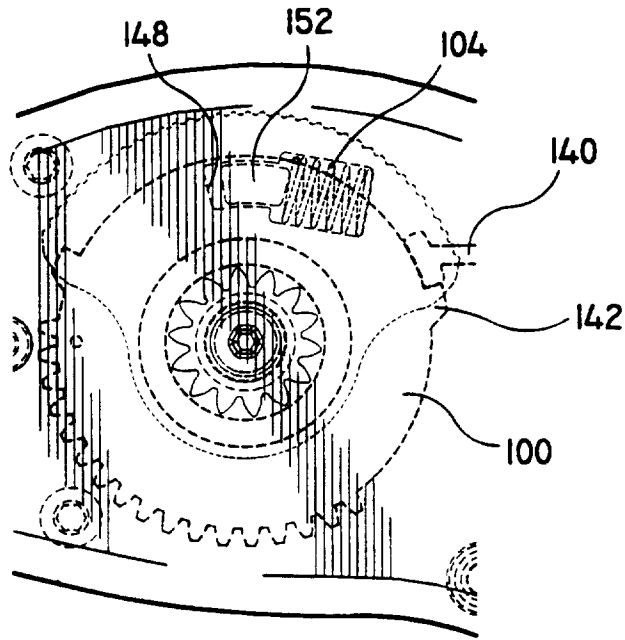

FIG. 14

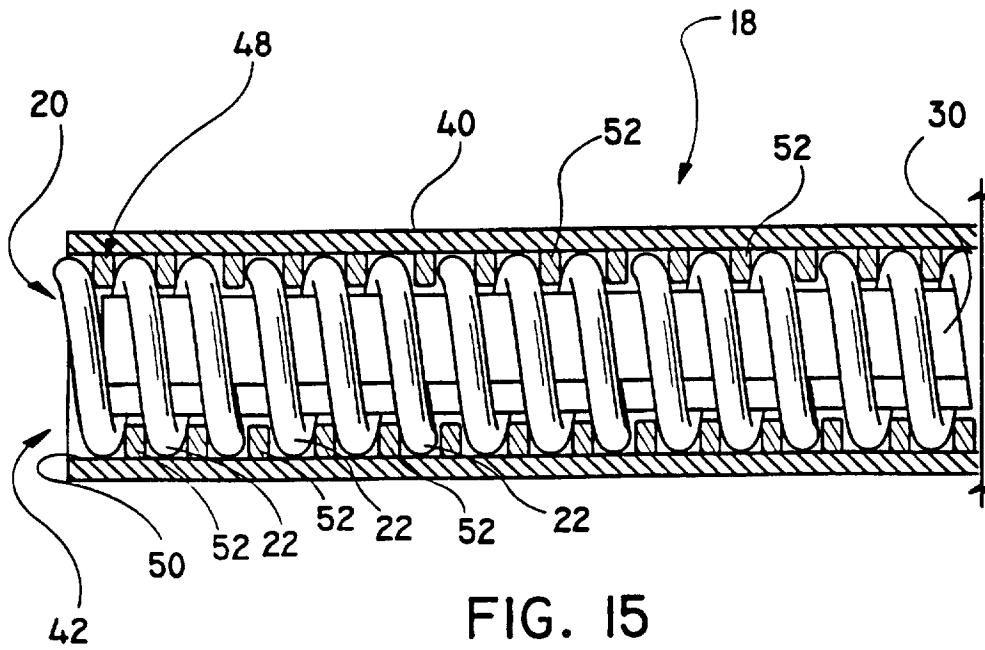

FIG. 15

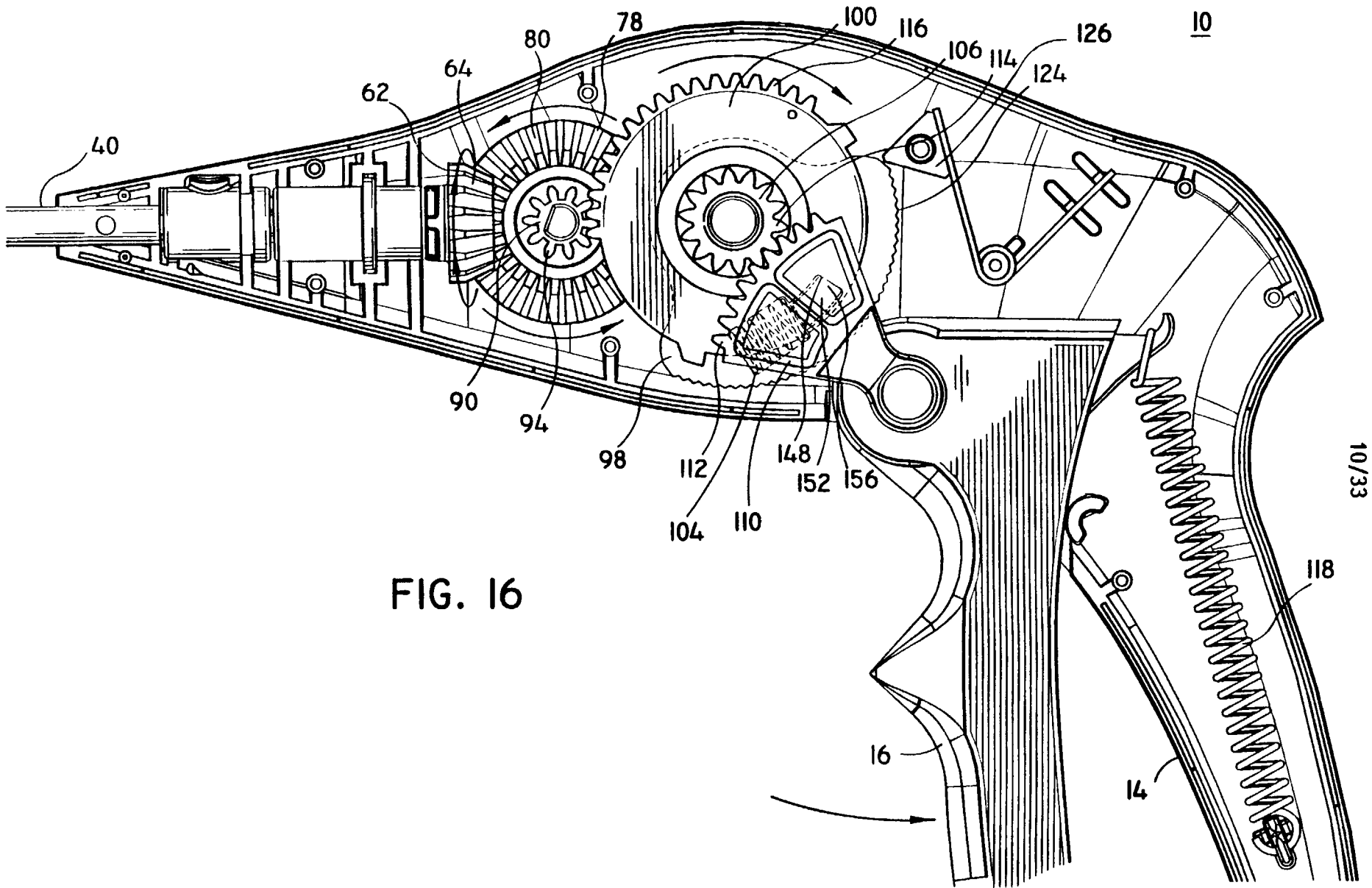

FIG. 16

11/33

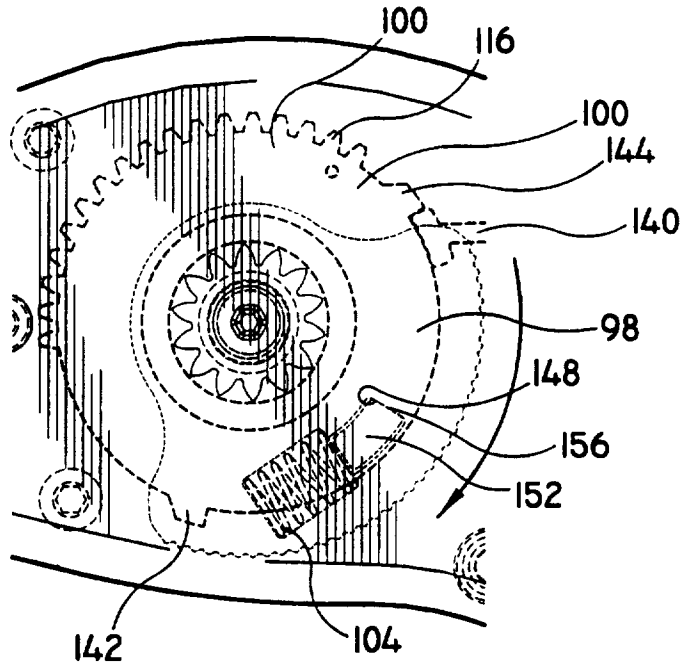

FIG. 17

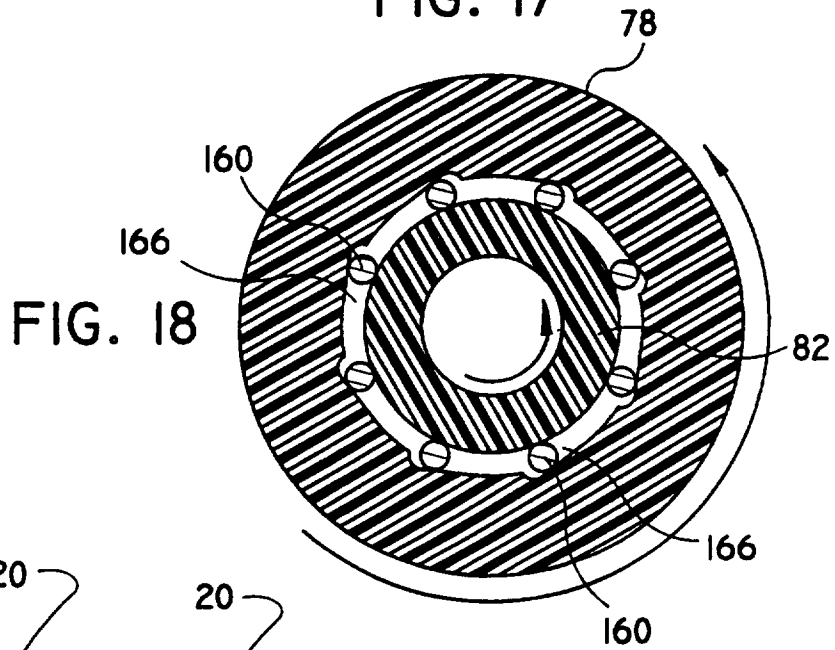

FIG. 18

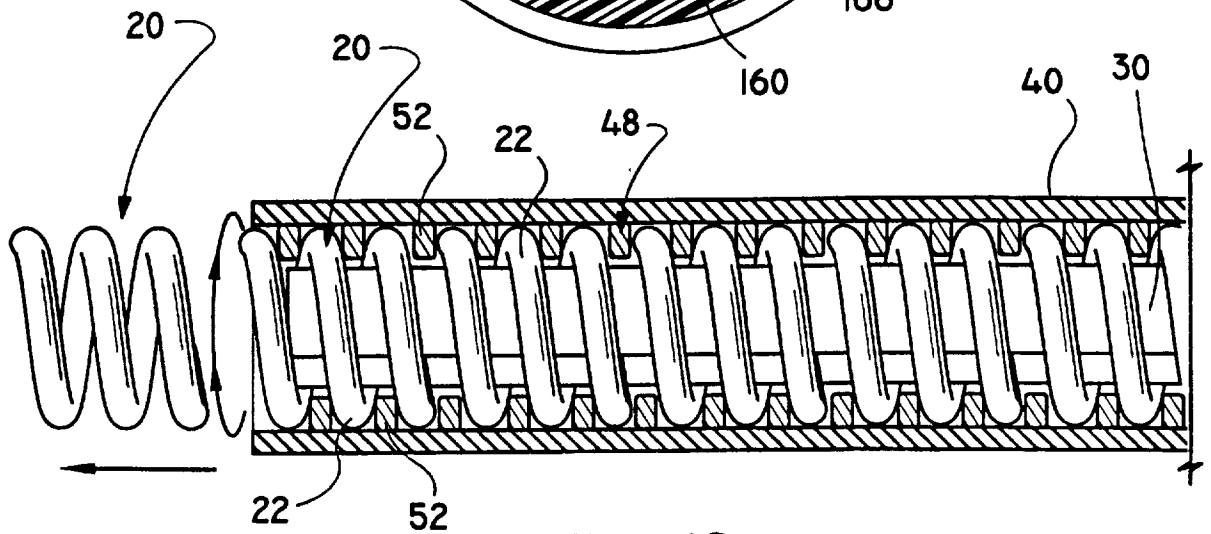

FIG. 19

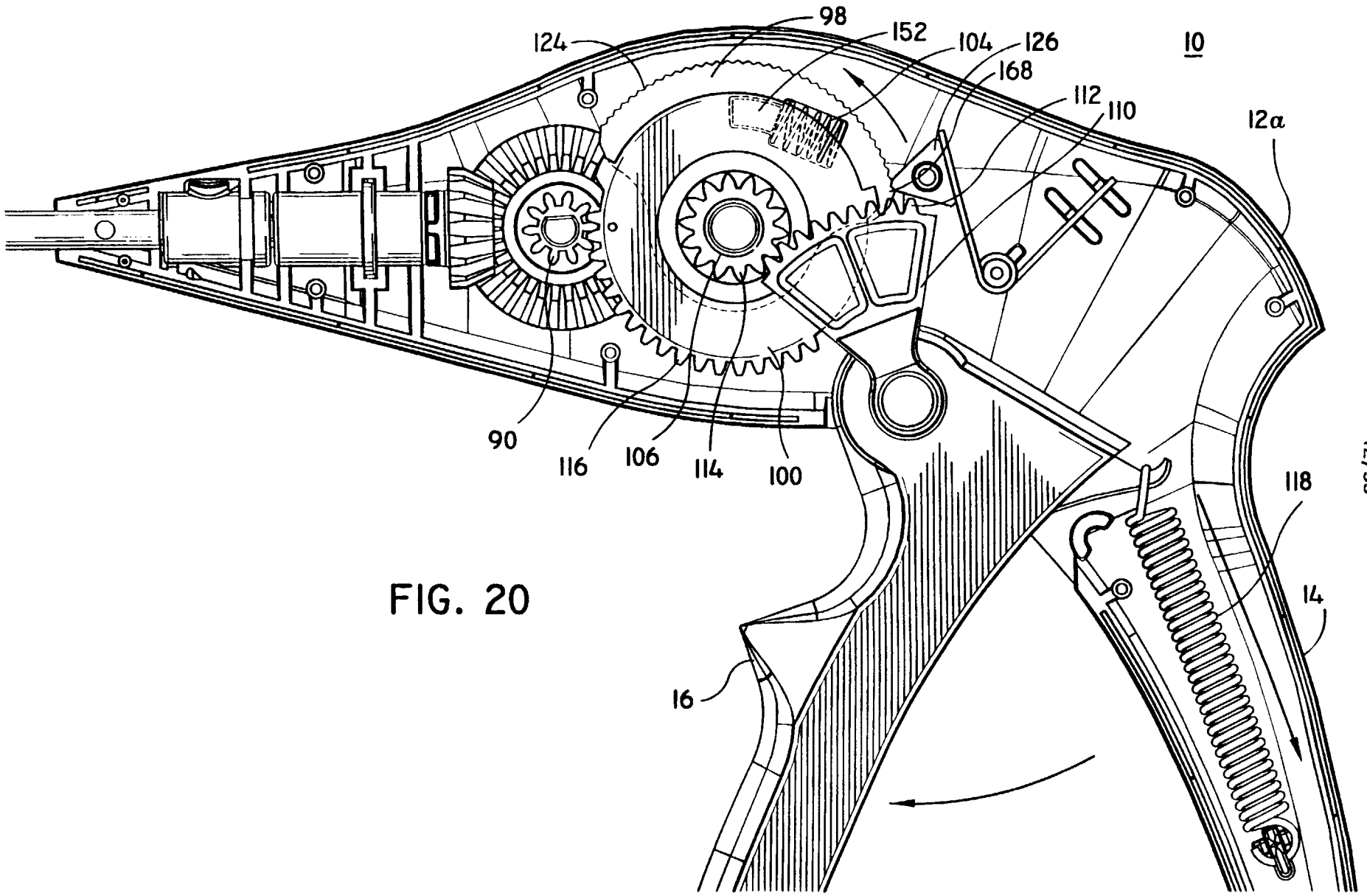

FIG. 20

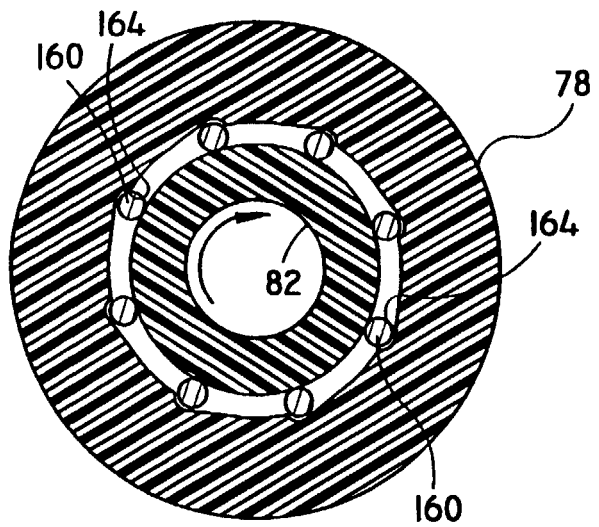

FIG. 21

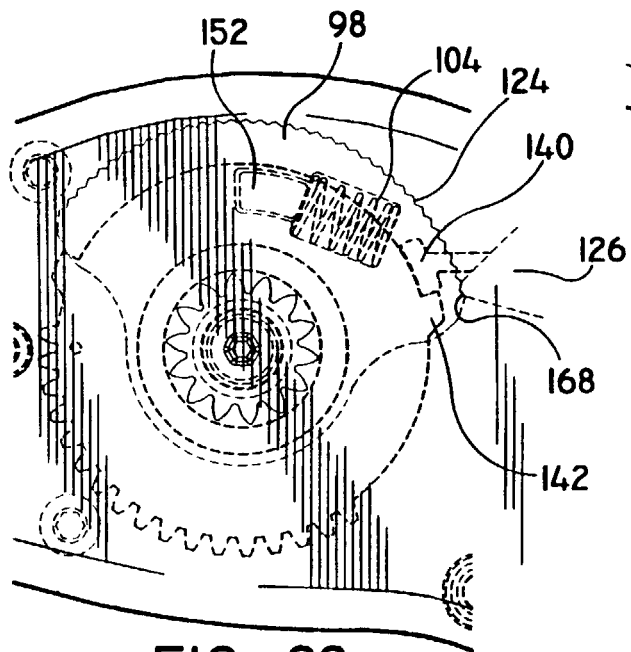

FIG. 22

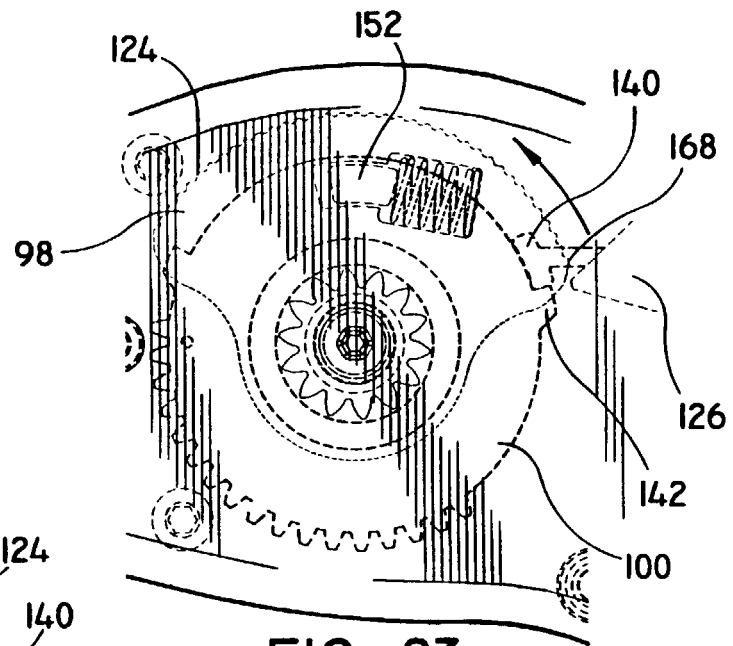

FIG. 23

FIG. 24

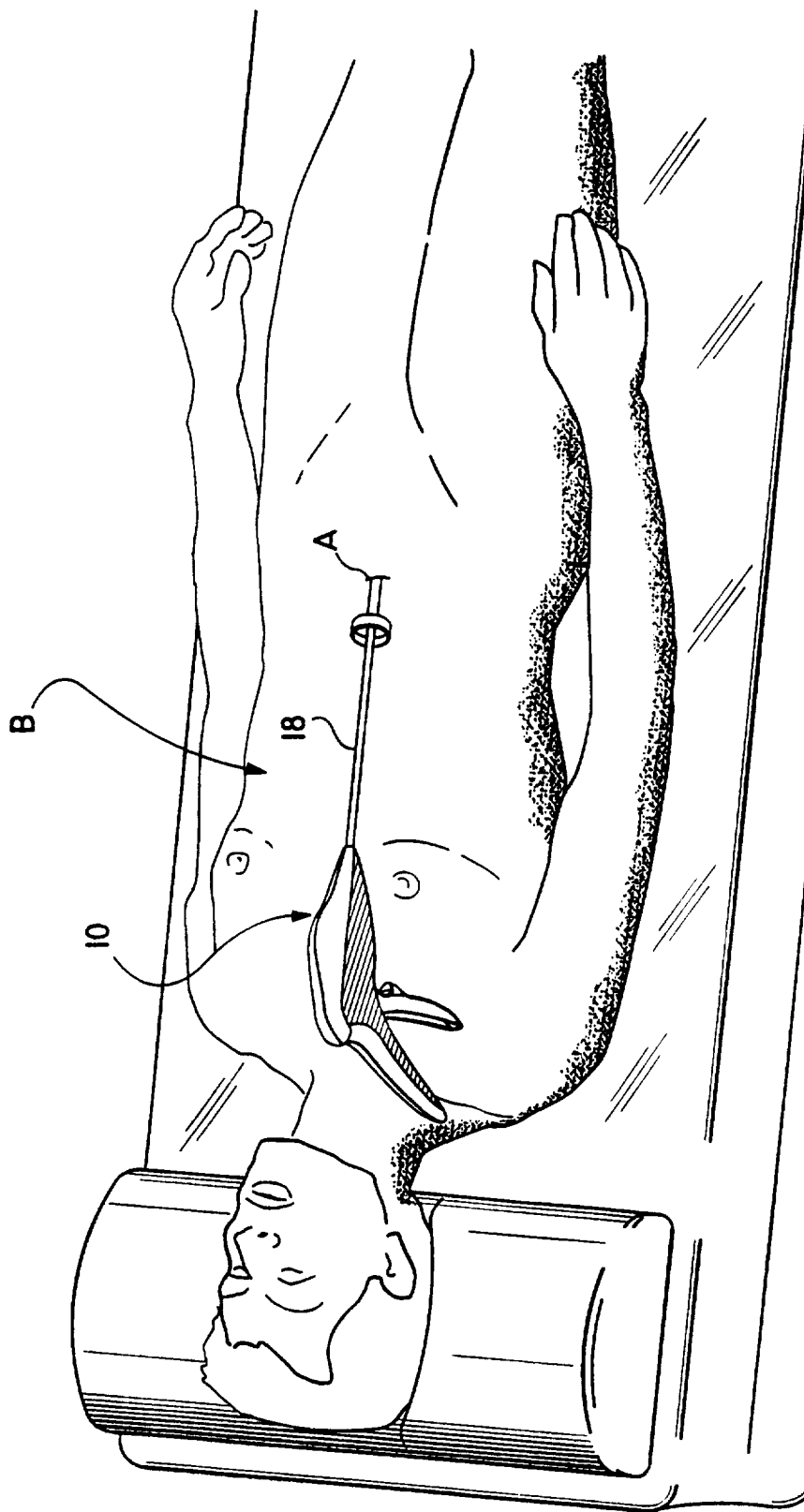
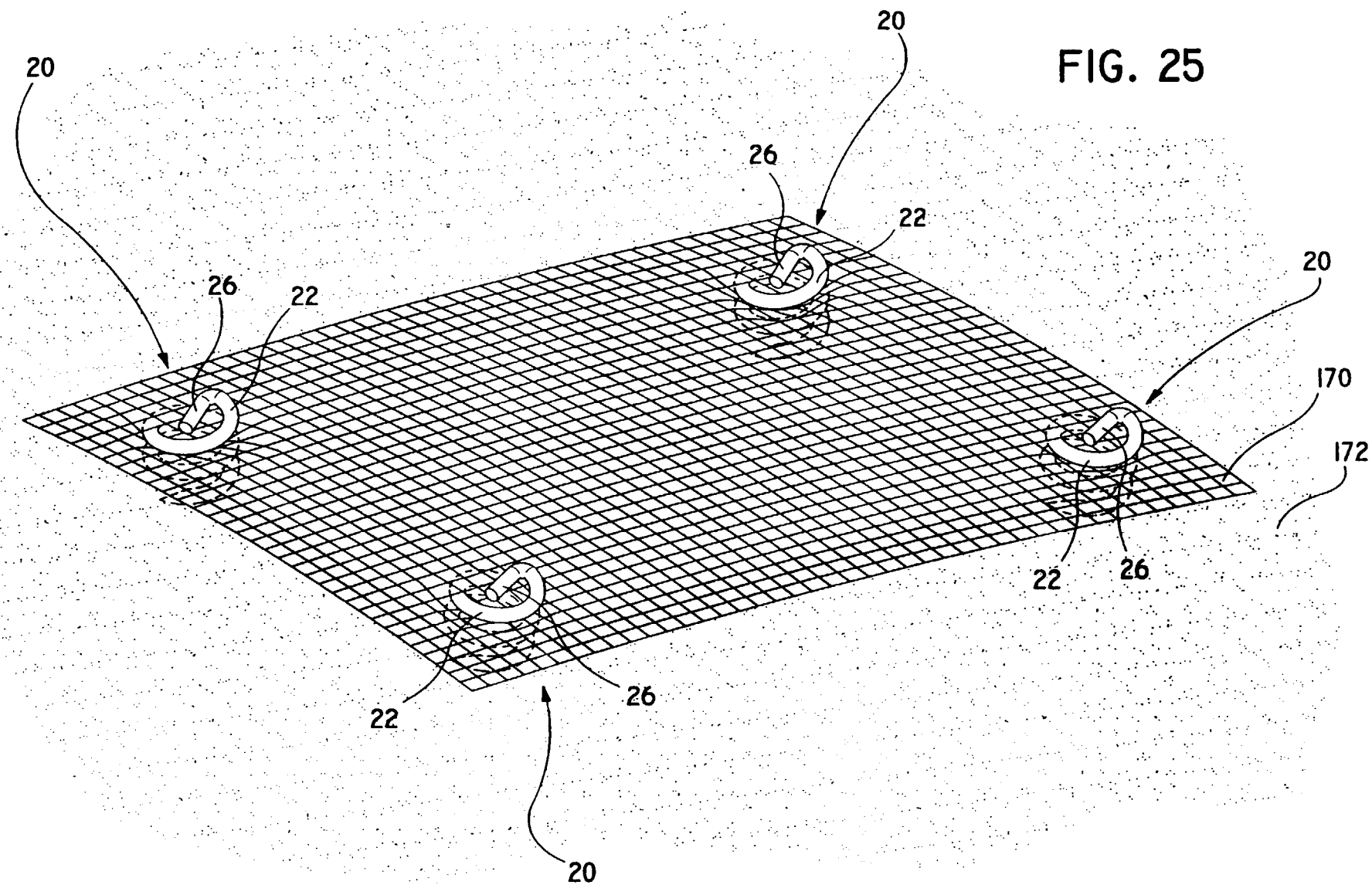

FIG. 25



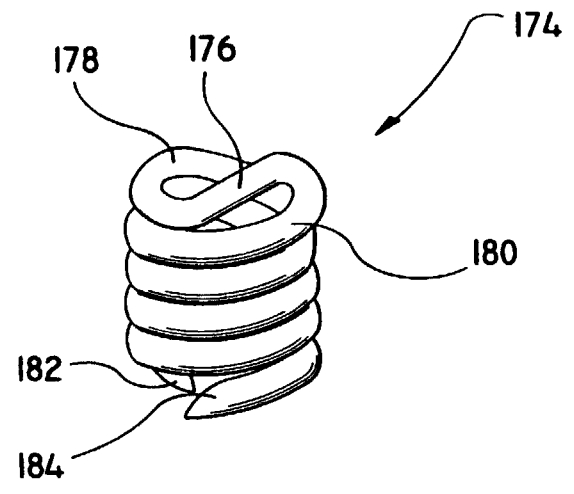

FIG. 26

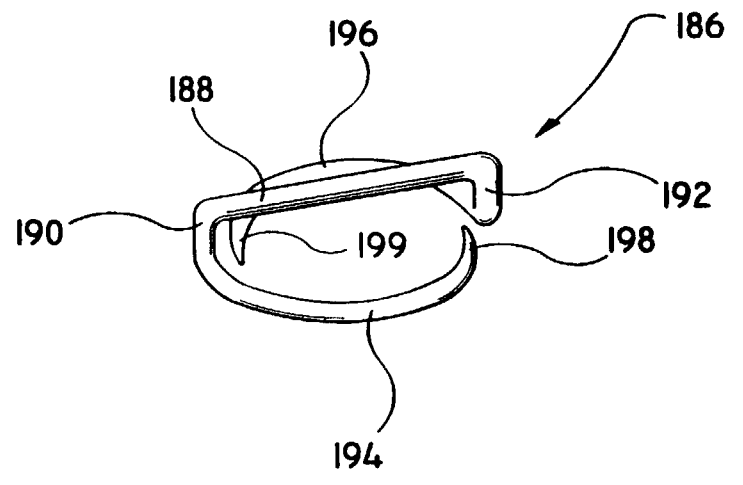

FIG. 27

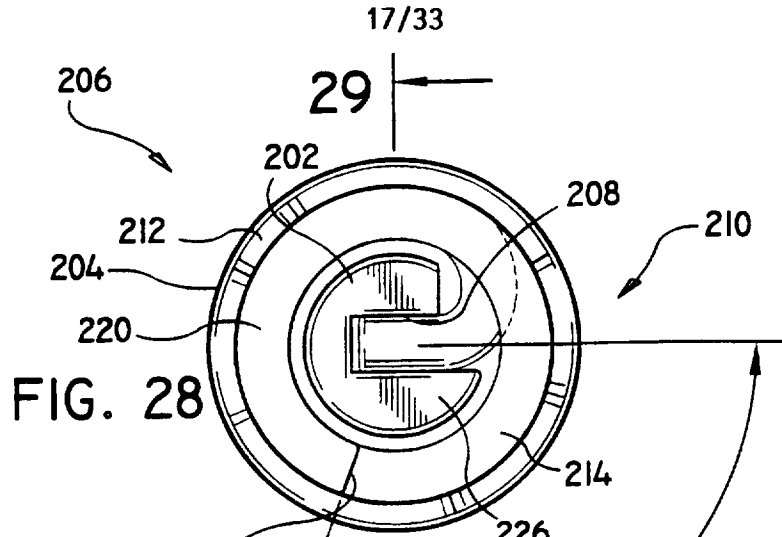

FIG. 28

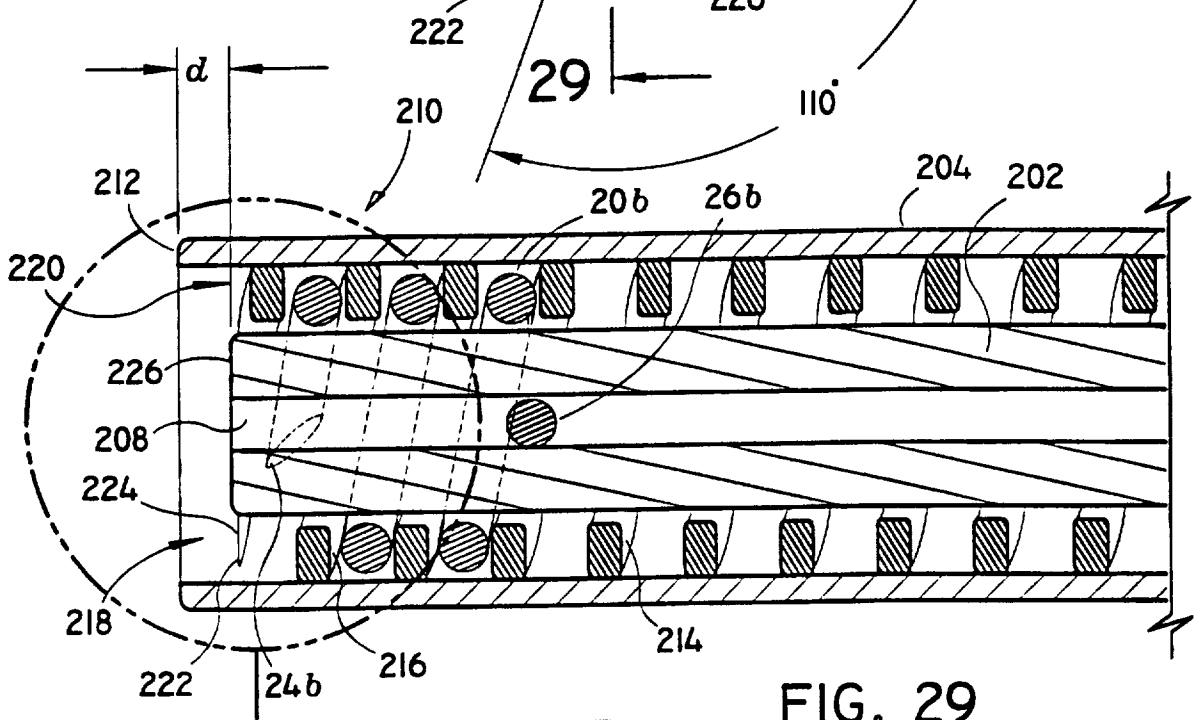

FIG. 29

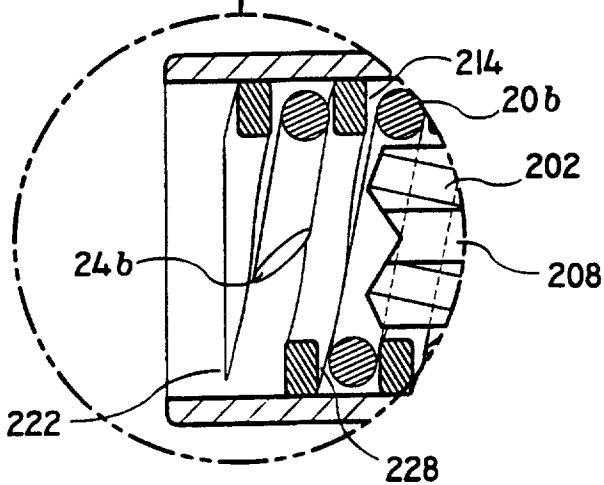

FIG. 30

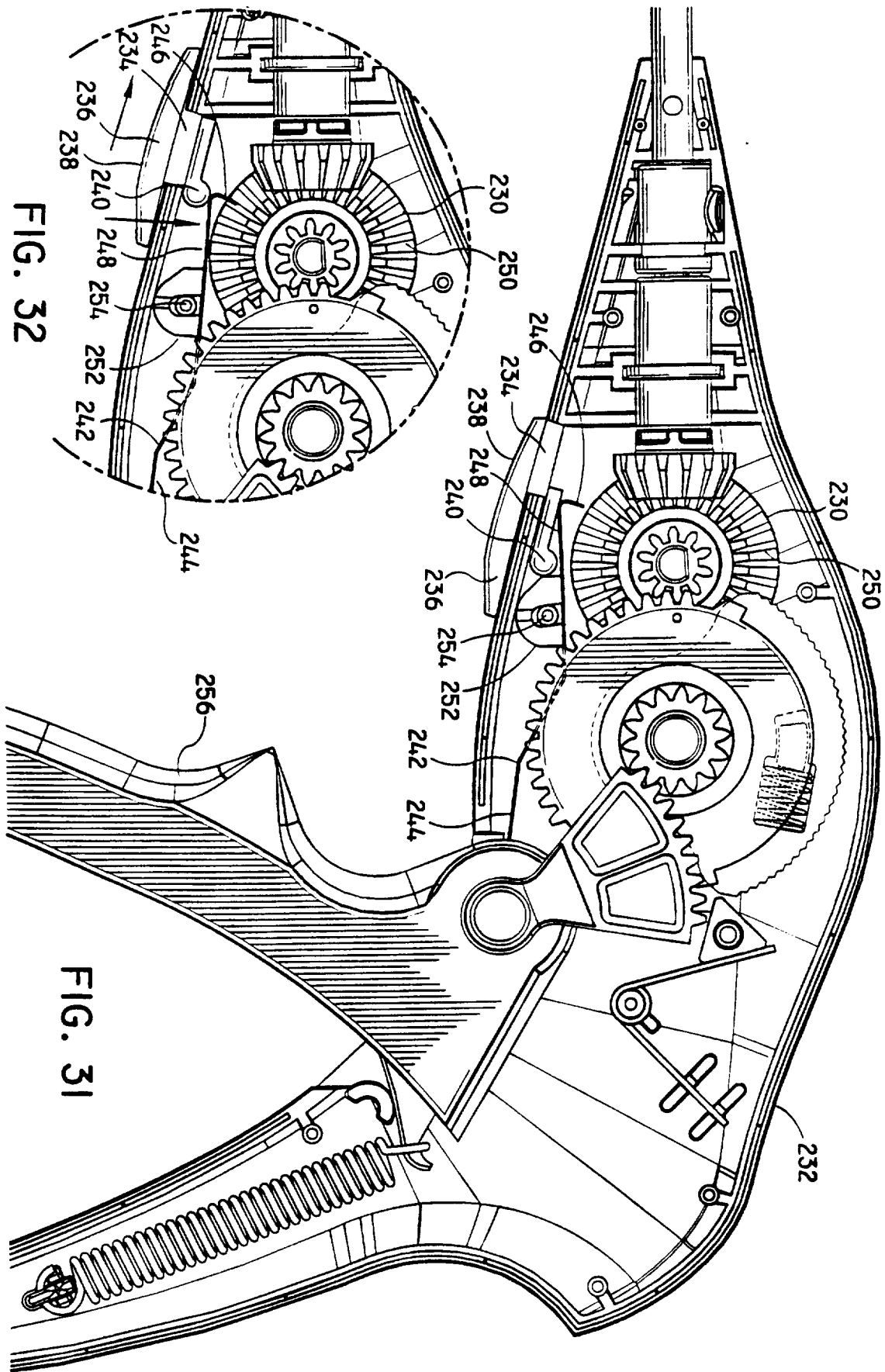
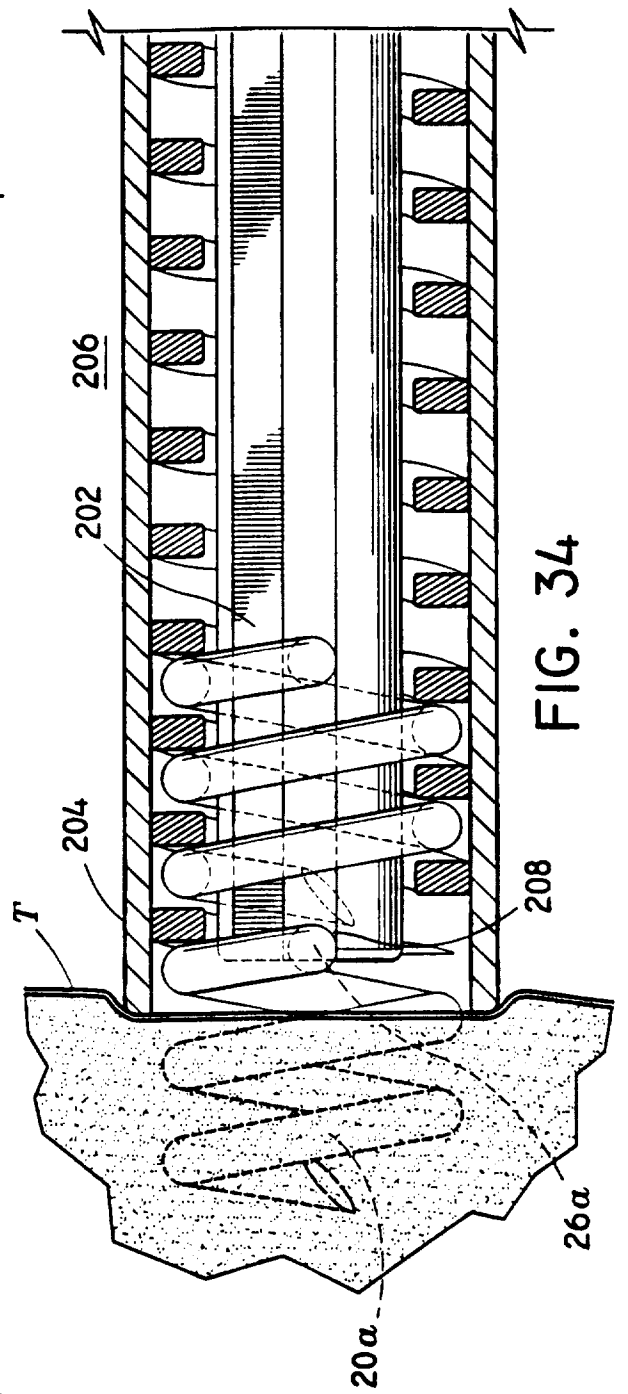
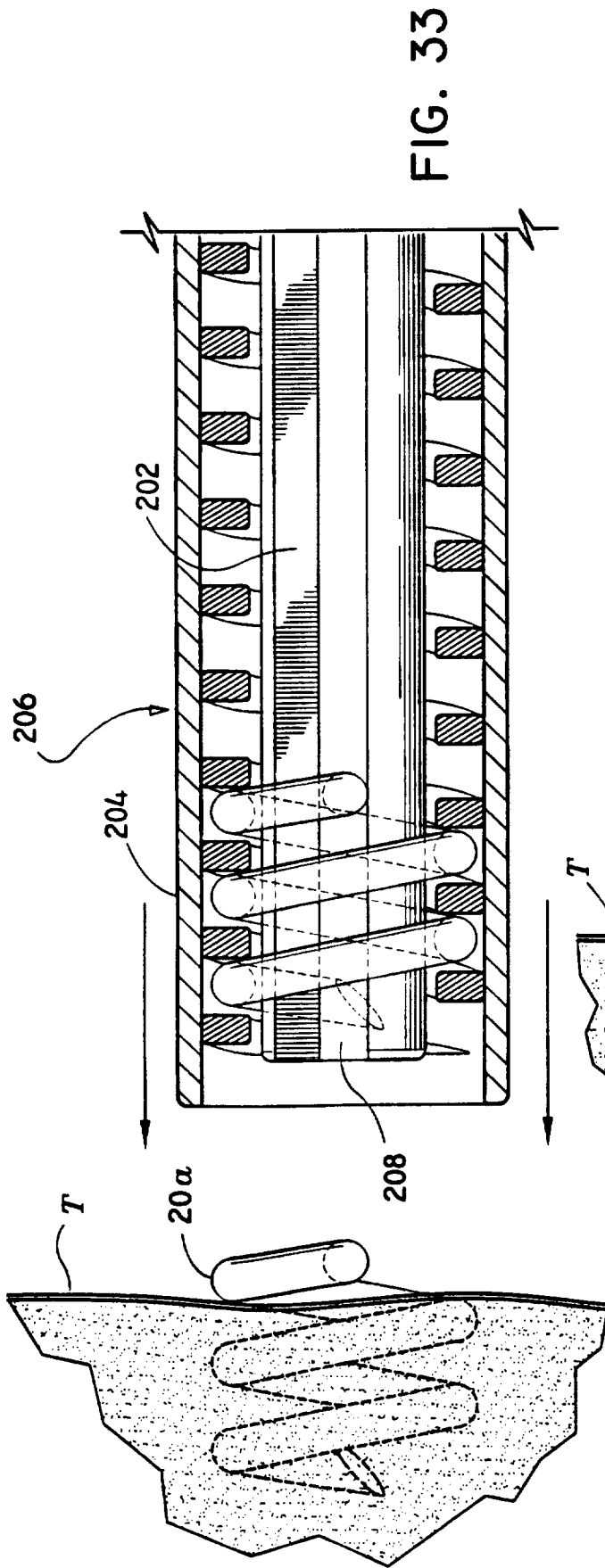

FIG. 32

FIG. 31



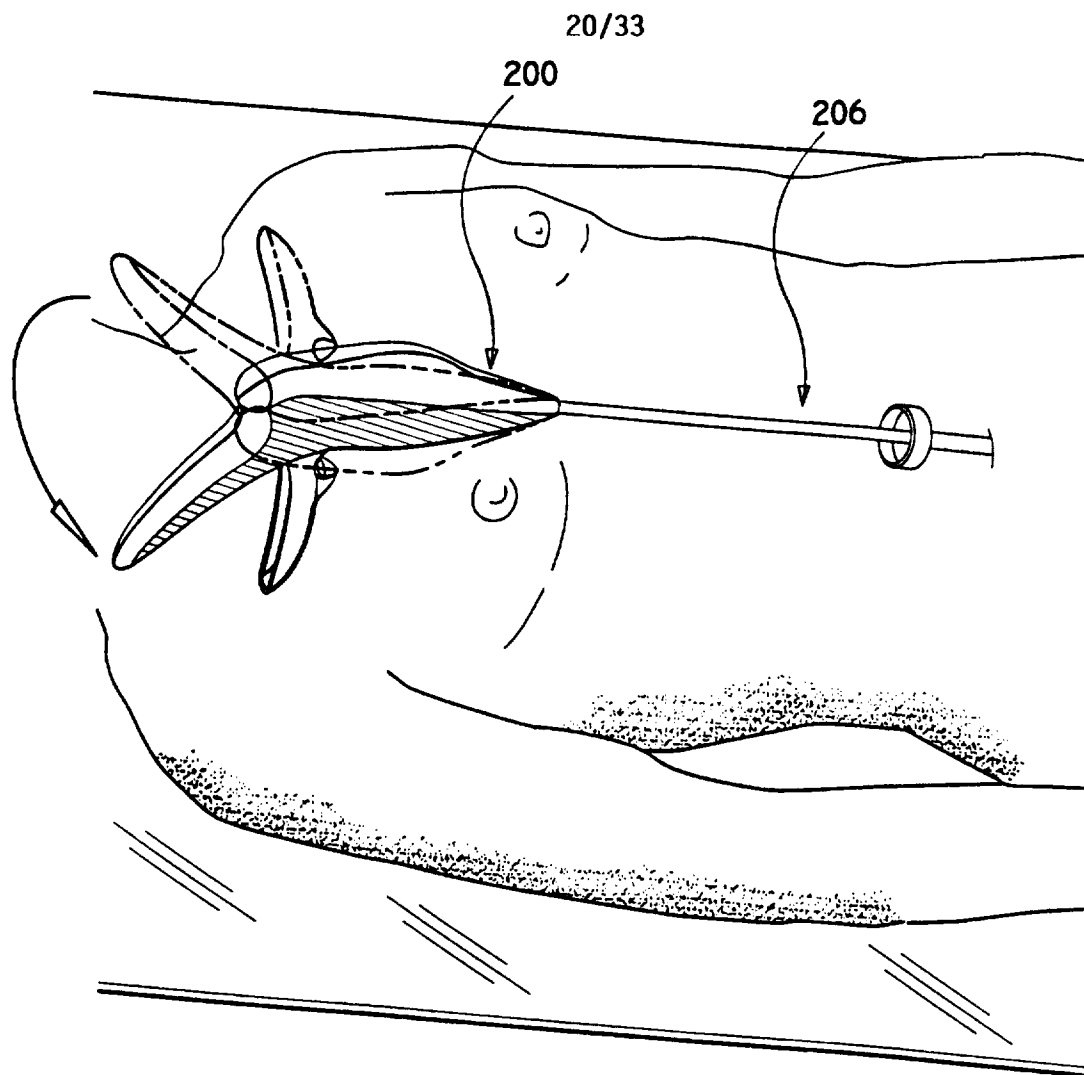

FIG. 35

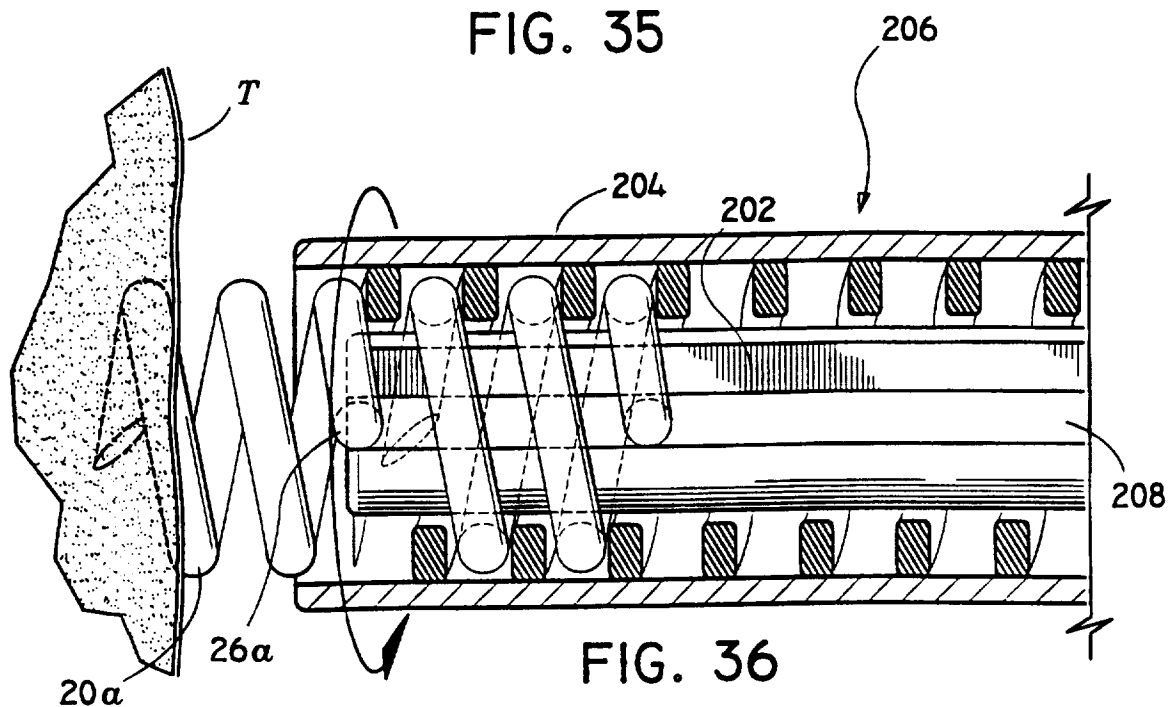

FIG. 36

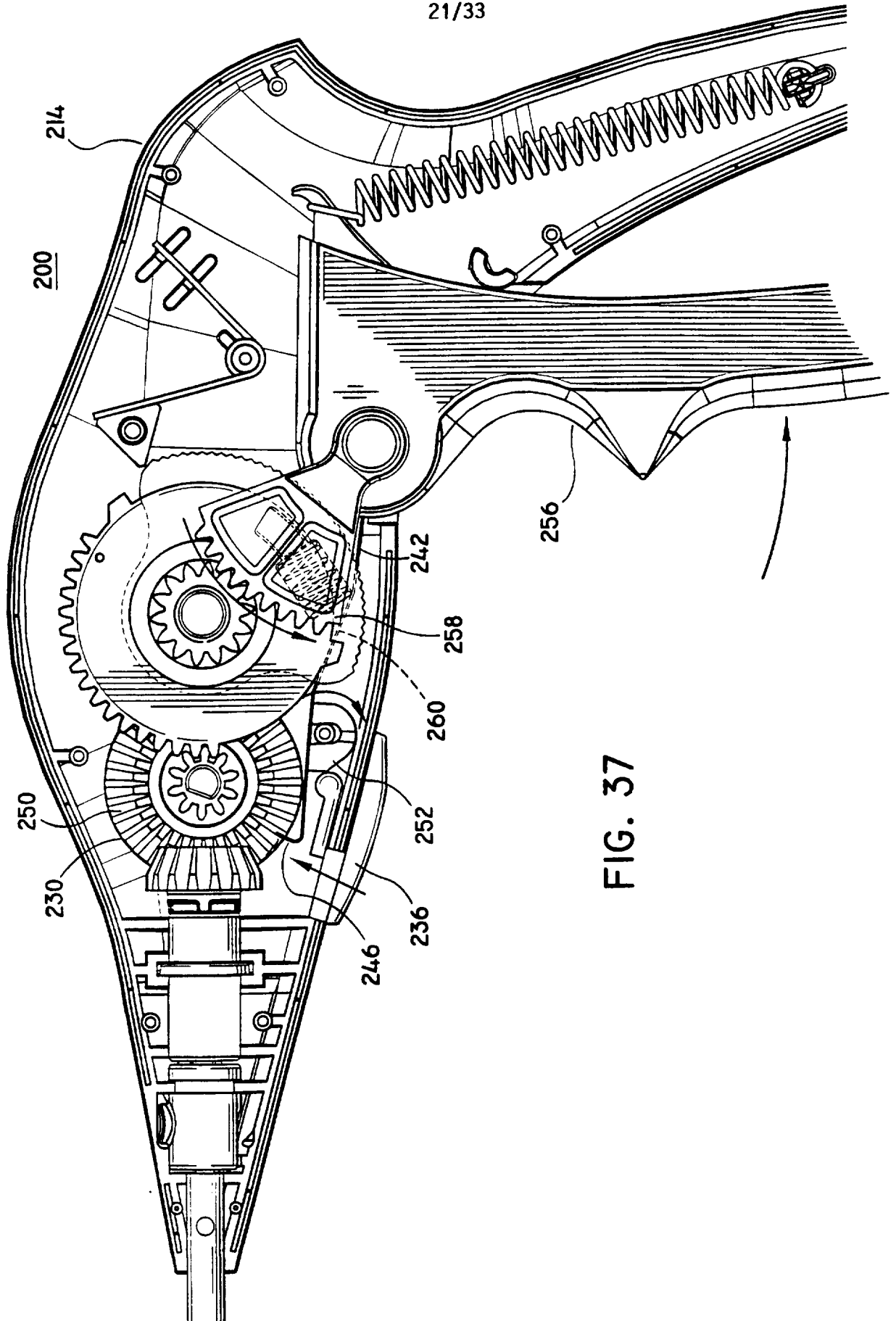

FIG. 37

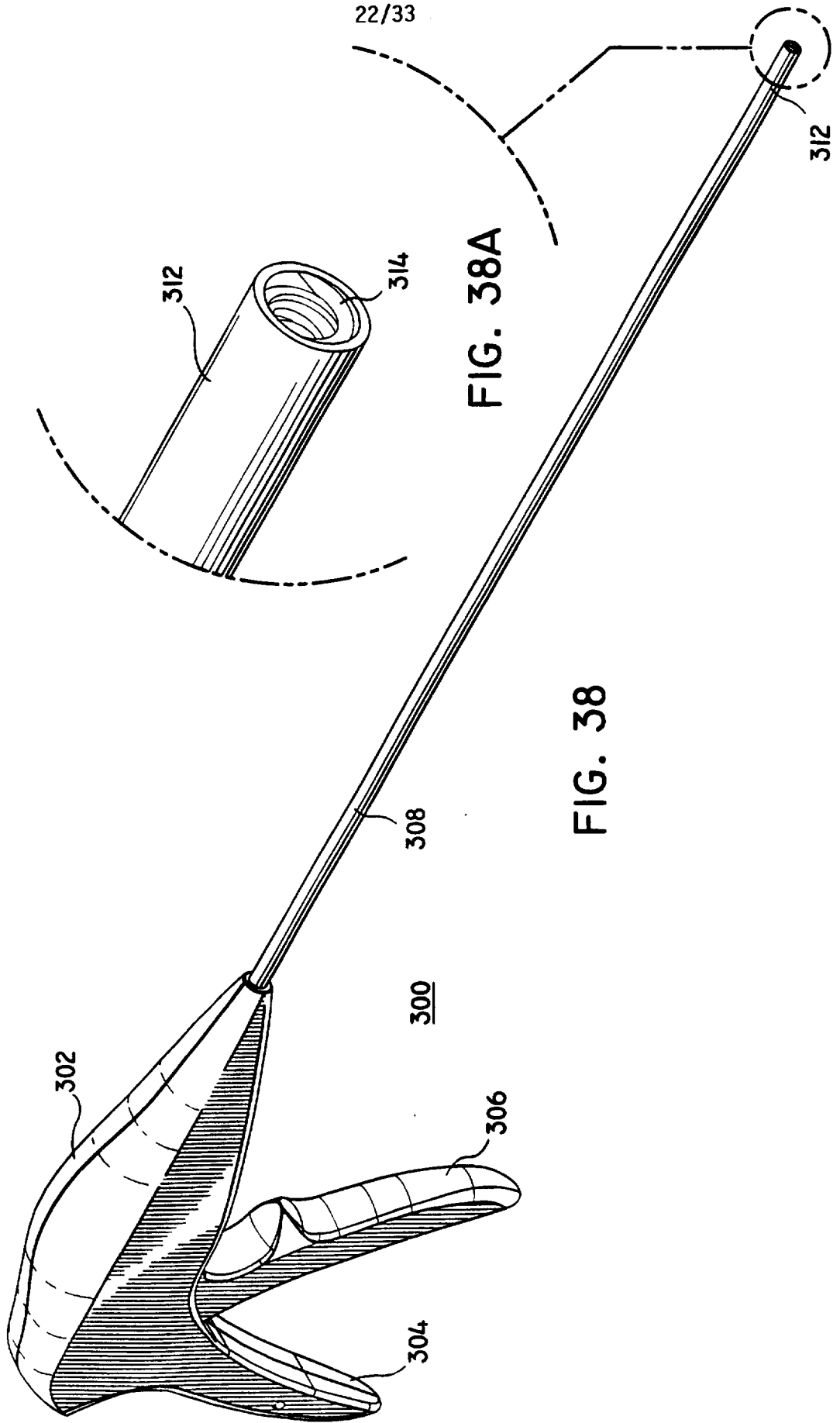
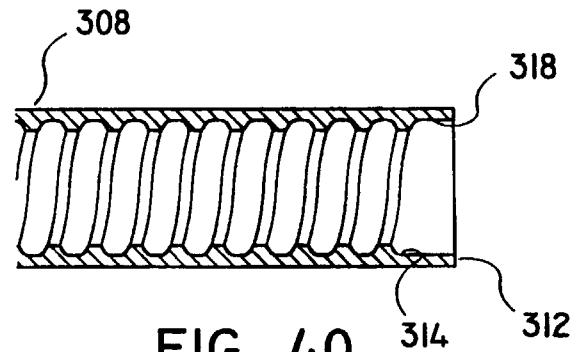
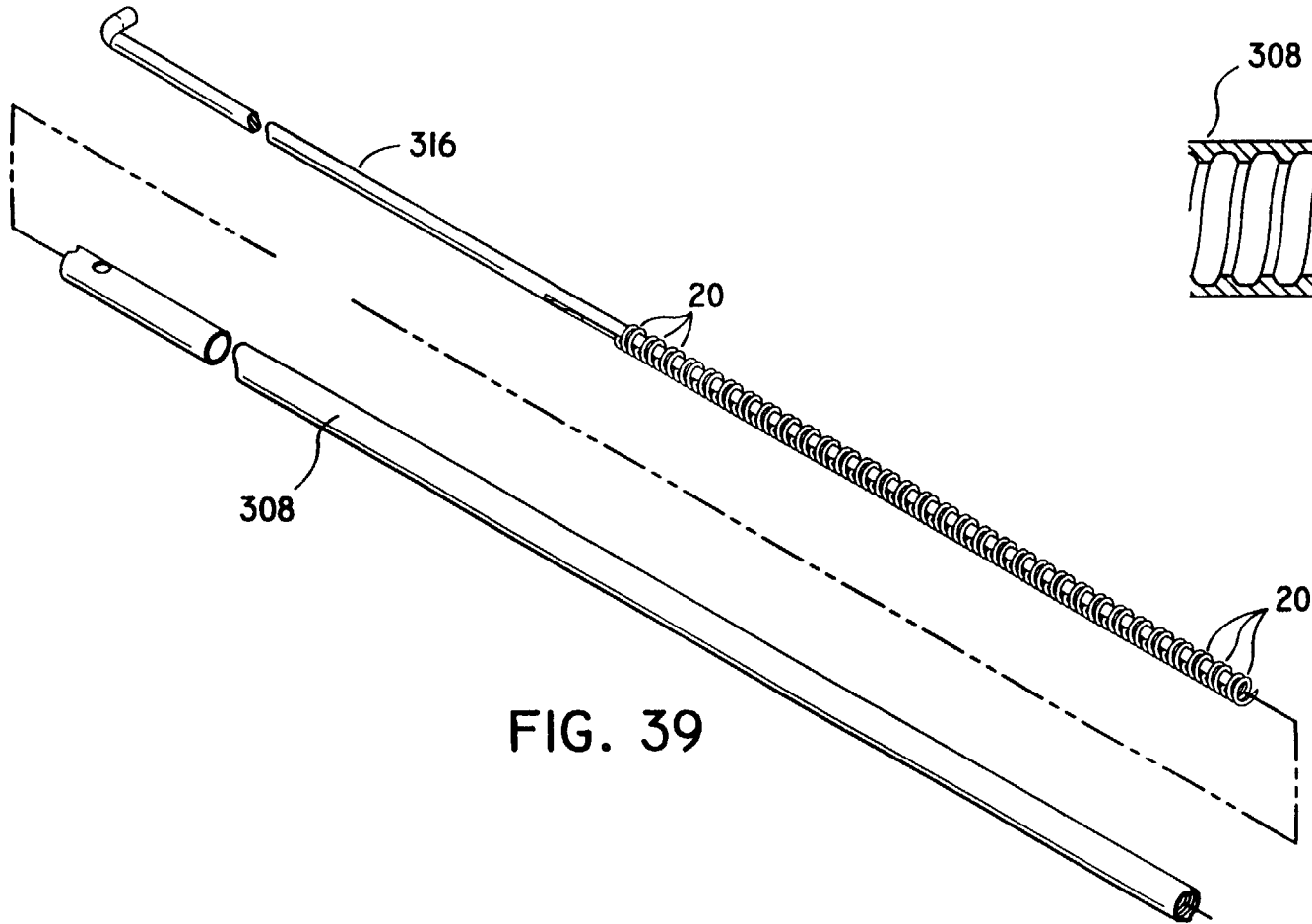

FIG. 38A

FIG. 38



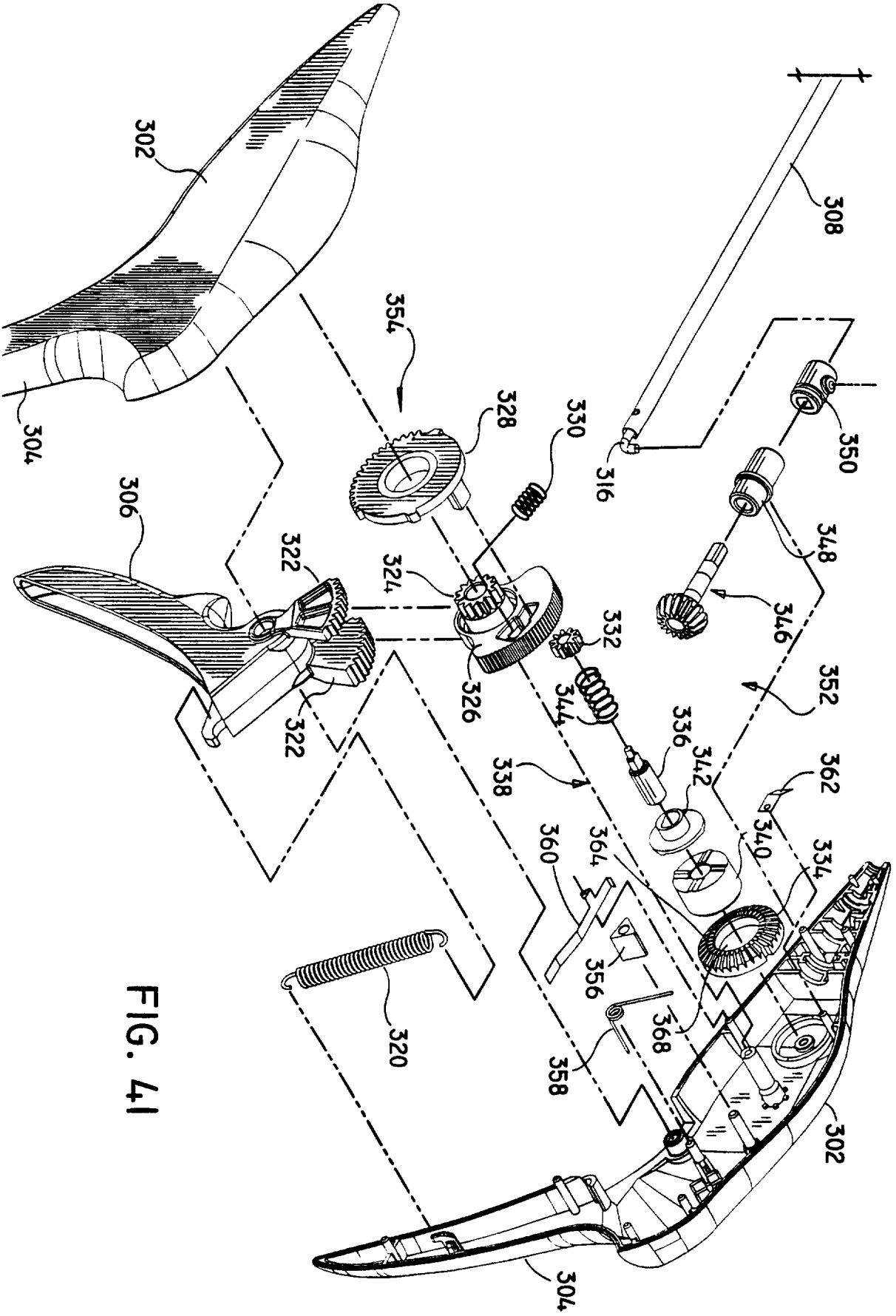

FIG. 41

24/33

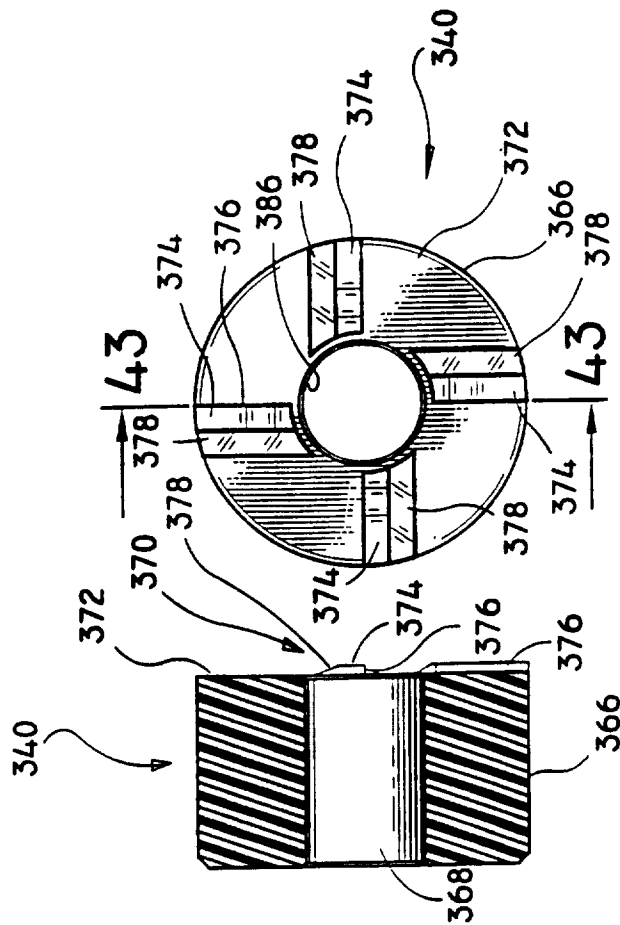

FIG. 42

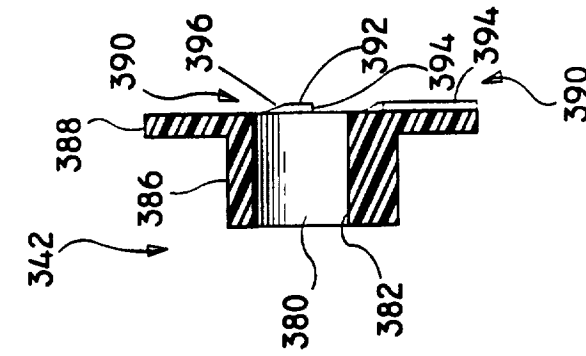

FIG. 43

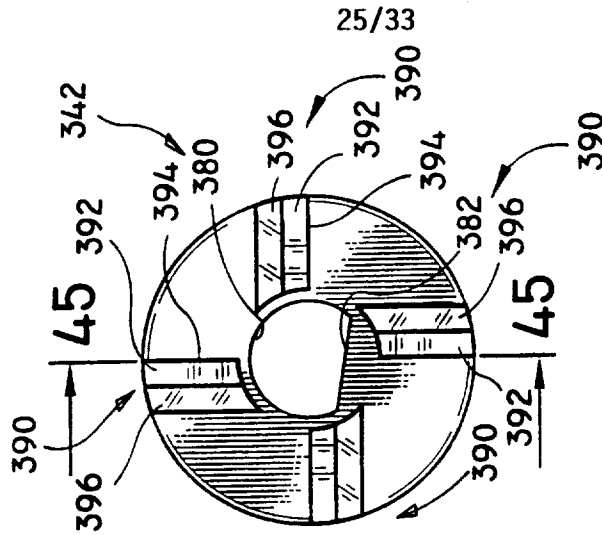

FIG. 44

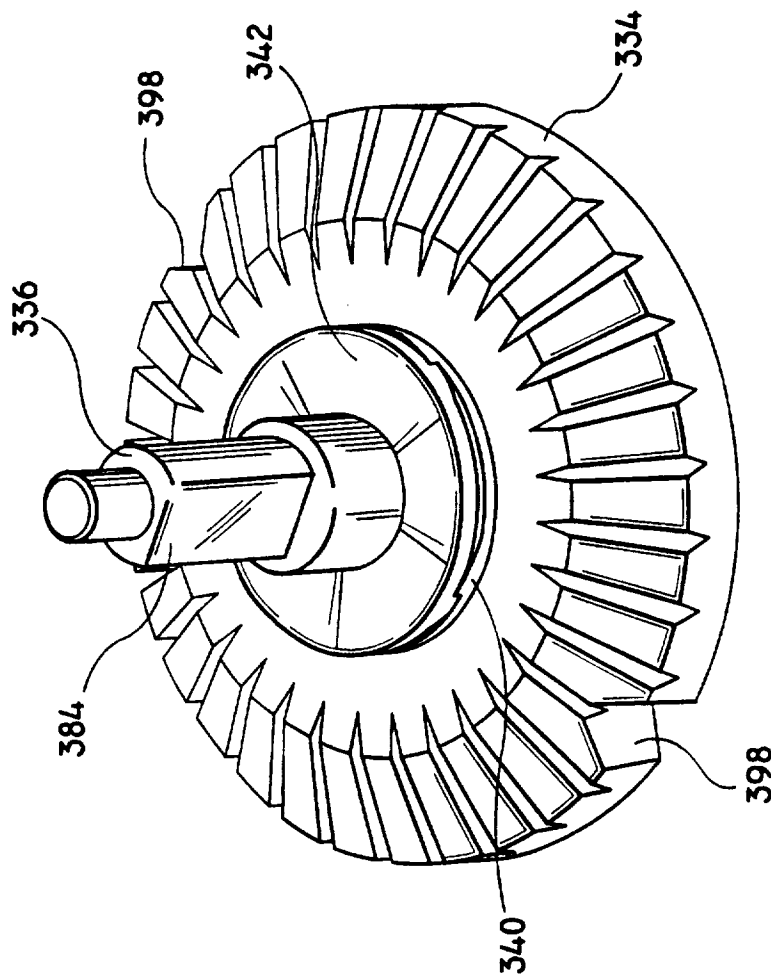

FIG. 46

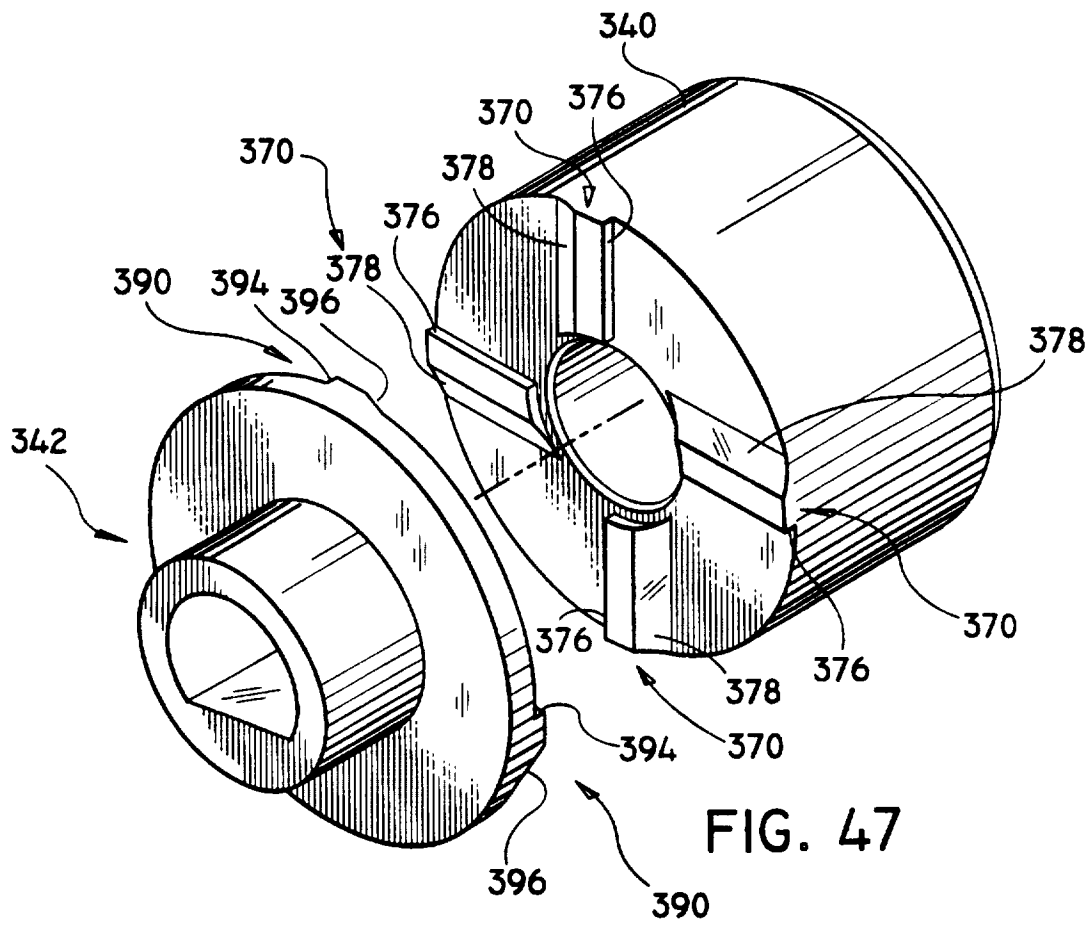

FIG. 47

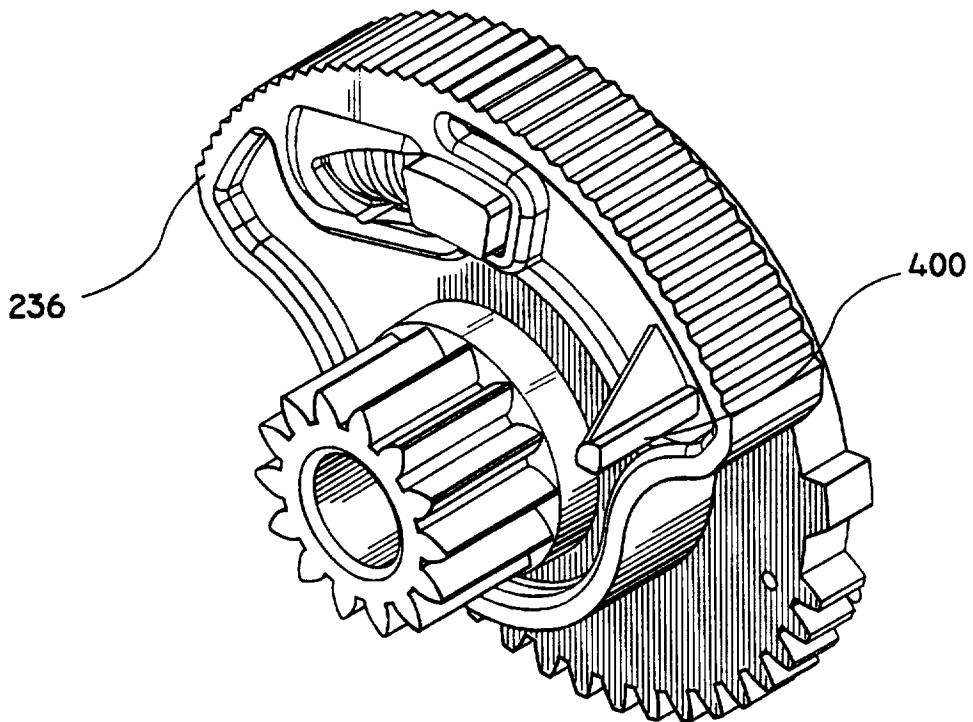
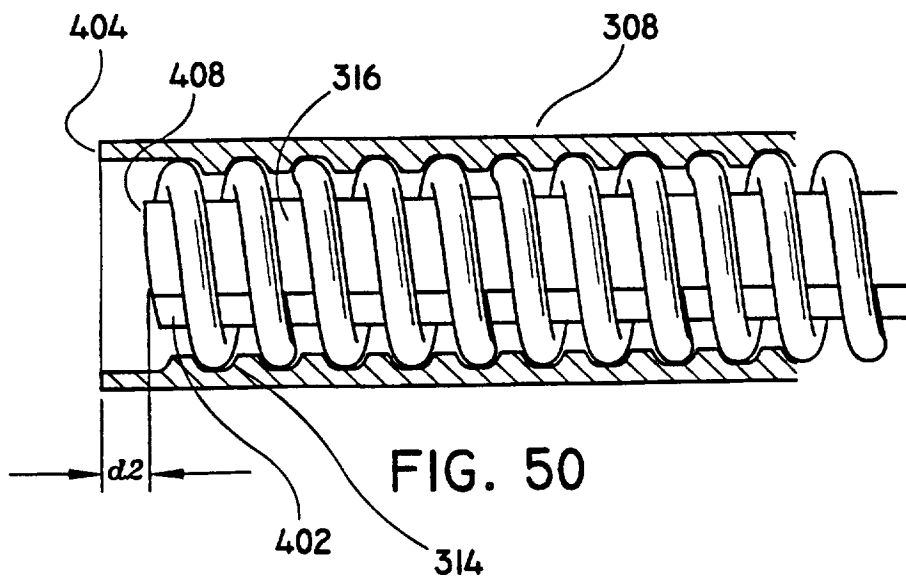
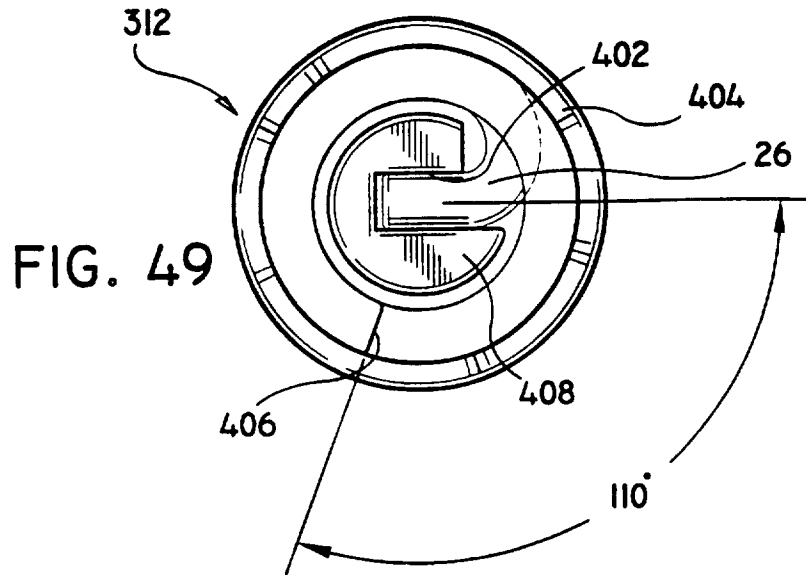

FIG. 48



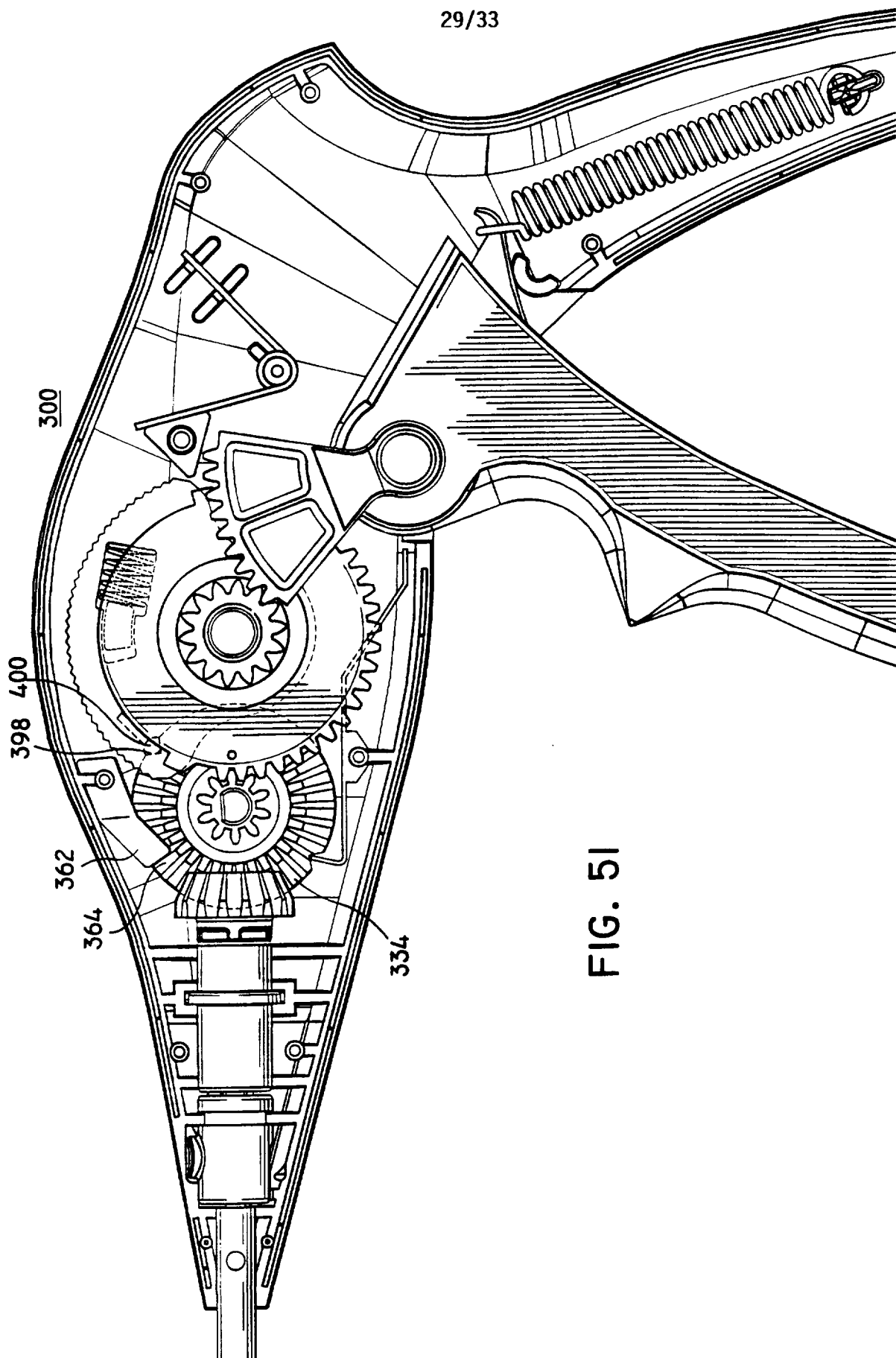

FIG. 51

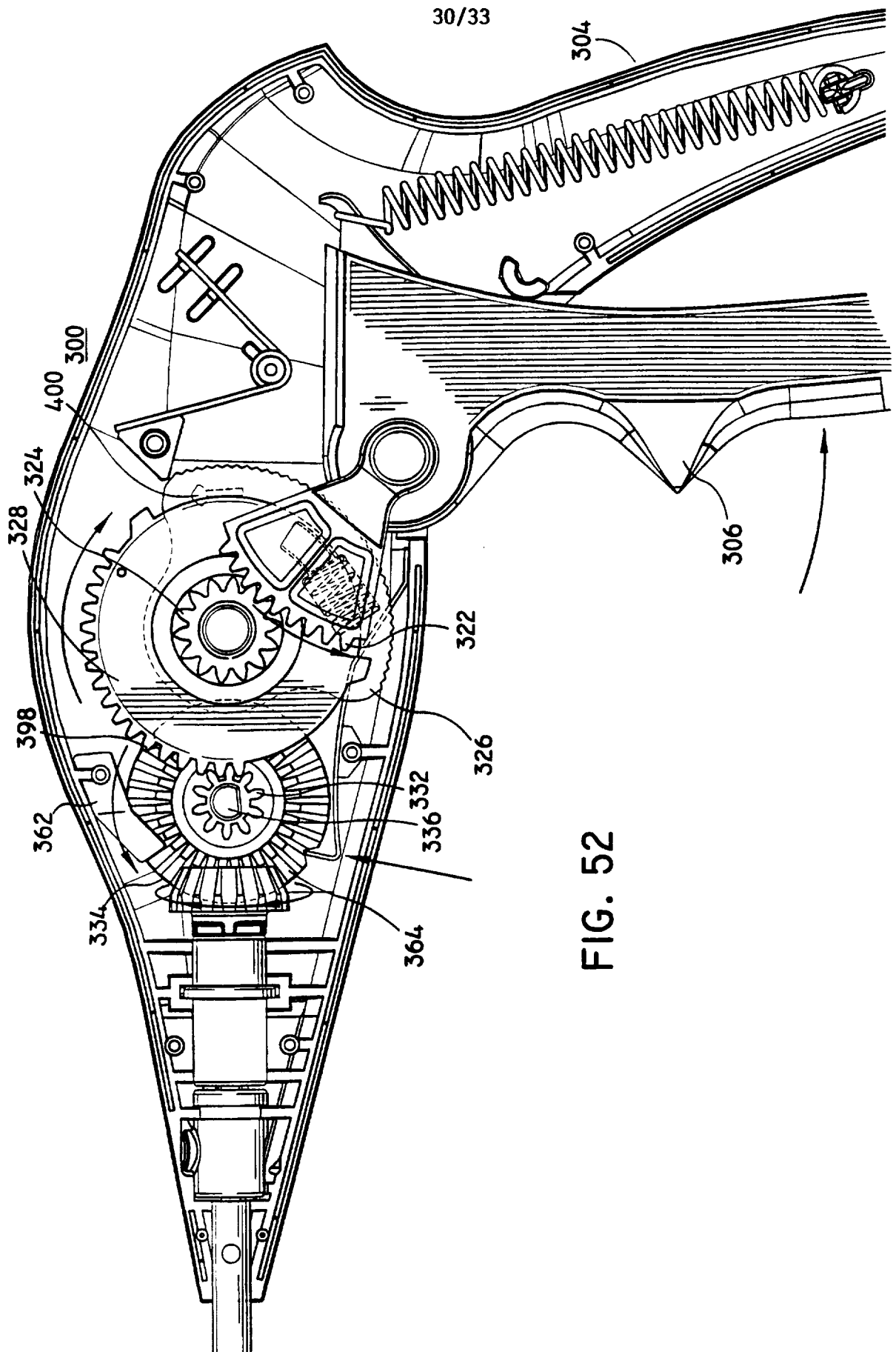
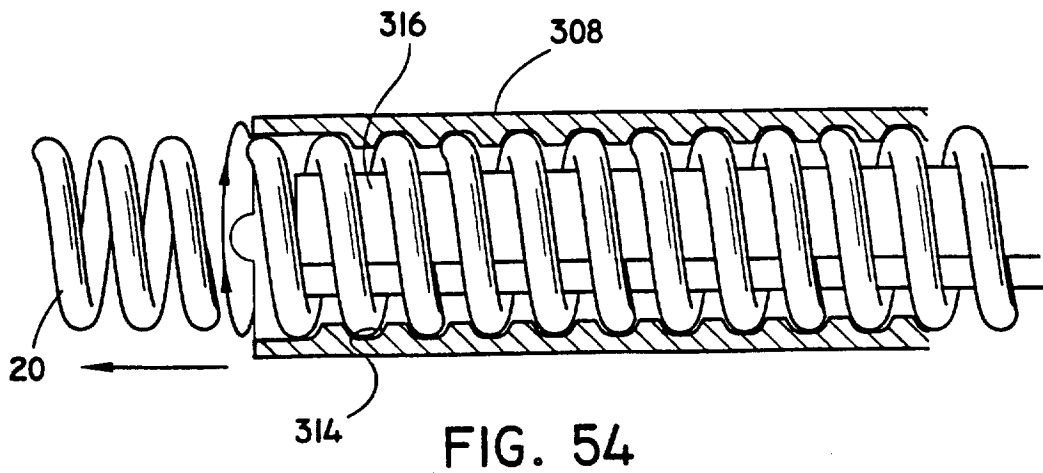
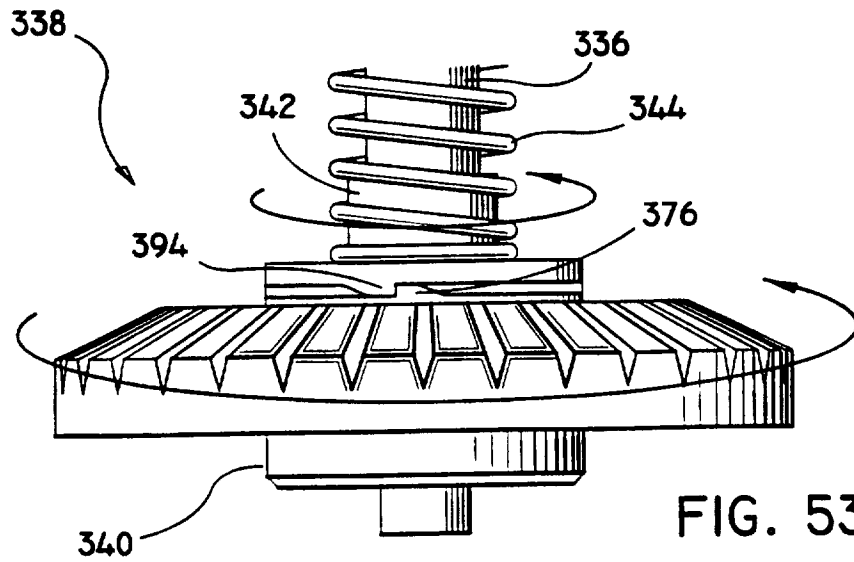
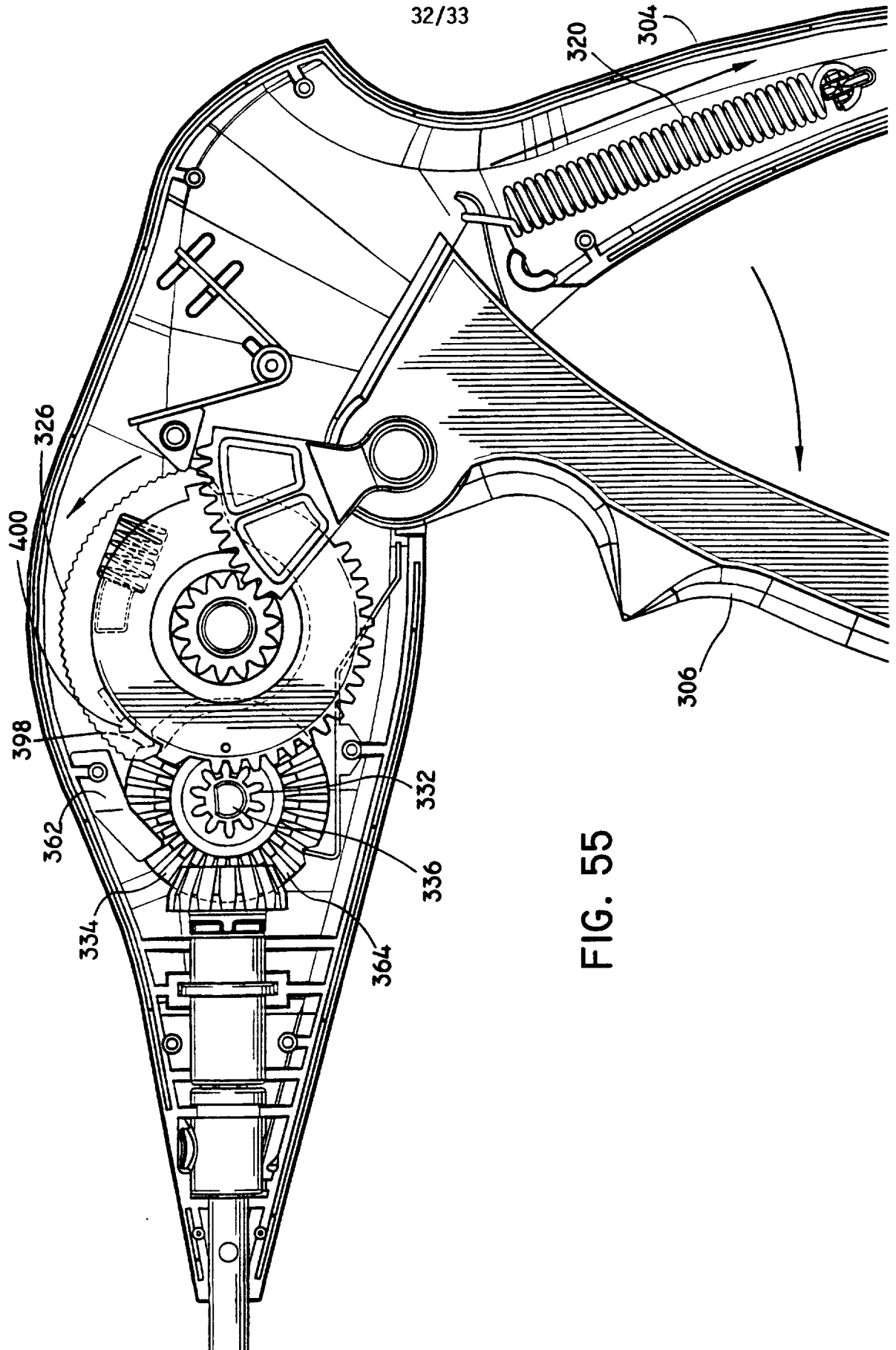

FIG. 52





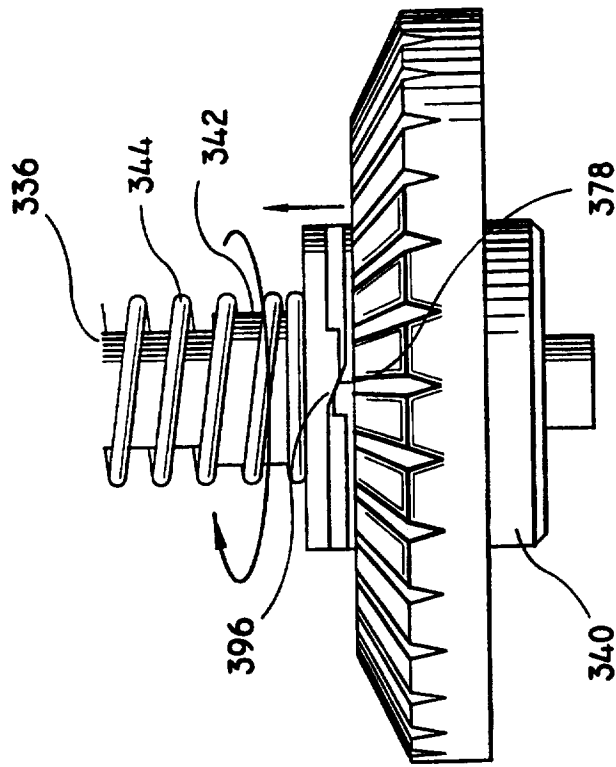

FIG. 56

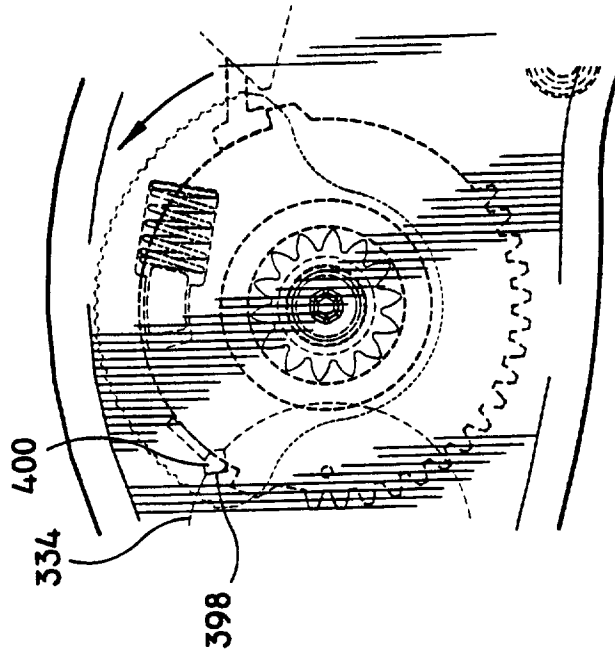

FIG. 57