

(19)
(12)

(KR)
(Y1)

(51) 。 Int. Cl. ⁷
G11B 33/02

(45)
(11)
(24)

2002 11 21
20 - 0295660
2002 11 05

(21) 20 - 2002 - 0026374
(22) 2002 09 03

(73) 3 416

(72) 2 1199 102 601

(74)
:
가 :

(54) /

1 , 1
가 2 ,
1 / 가 , 1 가
1 . , 1 2 가
3
, , , , ,

1 ,
 2a 2b 1 ,
 3 ,
 4 3 ,
 5
 .
 * *

100 : 110 :
 120 : 130 :
 240 : 241 : 1
 243 : 2 245 :
 245a : 245b :
 247, 247' : 247a :
 247b :

VCR, DVD, / ,
 .
 1 / (100) .
 , (100) 가 ,
 가 .

1 , (100) () (110) ,
 (110) (120) , (110)
 (130) (120) (100)
 (125) , (121) .
 (100) (120) (110) ()
 가 , ,

, , 1 2b , (120) (110)

(140) 1 (141) , 2 (143) , 1 2 (141)(143)
(145) (147) , (145) 1 (141)

(140) (120) .

, 2a , (120) (110) . , 1 (141) 2 (143)가 , 2a (120)
(110) 1 2 (141)(143) ,
(145) 2 (143) 1 (141)

, 2b , (120) (145)가 (147) (145) (1
47) , (145) (147) , (145) (147) (1
120) (110) .

(140) (145) (147) (100)
(120) (147) , (100) 가 (X) (120)
(145) (147) 가

가 / , / .

가 2 , 1 , 1 ,
1 1 가 ,
1 1

가

가

가

2

1 2b / 가 /

3 (245) (247) (240) , 1 (241) , 2 (243) ,

1 (241) (110) (120)

0) 2 (243) (120) (110) 2 (247)

1 (241) (120) (247) 1 (241)

1 (241) (245a) , (245a) 2 (243) (247) (241)

5b) 1 (241) 2 (243) (247) (245b) (241) (243) (247) (241) (245b)

(100) (120) (110)

1 (241) 2 (243)가 (120) (110)

(243) (120) 1 (241)가 2 (243) 3 (A) (245) 2

1 (241) 2 (243)가 (110) (245) 2 (243) 가 (245)

(247) (120) (245) 2 (243) (245b) 1 (241)

(247) (120) (245b) 1 (241) (241) (245) 4

(247) (120) 1 (241) 2 (243)가 (245b)

1 (241)가 (100) 가 (X; 1) 2 (243)가

2 (243) (100) 가

5 (240) (240) (241) (247a) 2 (243)

40) (245b) (120) (247) 가 (247)

(247) 가 . (120) (245b)
 (245b) (247a) , 1 (243)
 (100) 가 (247) (247b) . ,
 20) (110) (120) (1

(245b) (247a) 2 (243)
 (241)(243) 가 가 . (247) (245) 1 2
 가 가 .

VCR, DVD
 가

, 가 가 ' 1 2 가
 가 /

가 .

가 .

(57)

1.

1 ;

가 2 ; 1

1 ,
 가 ; ,

1

2.

1 ,

가

2

가

/

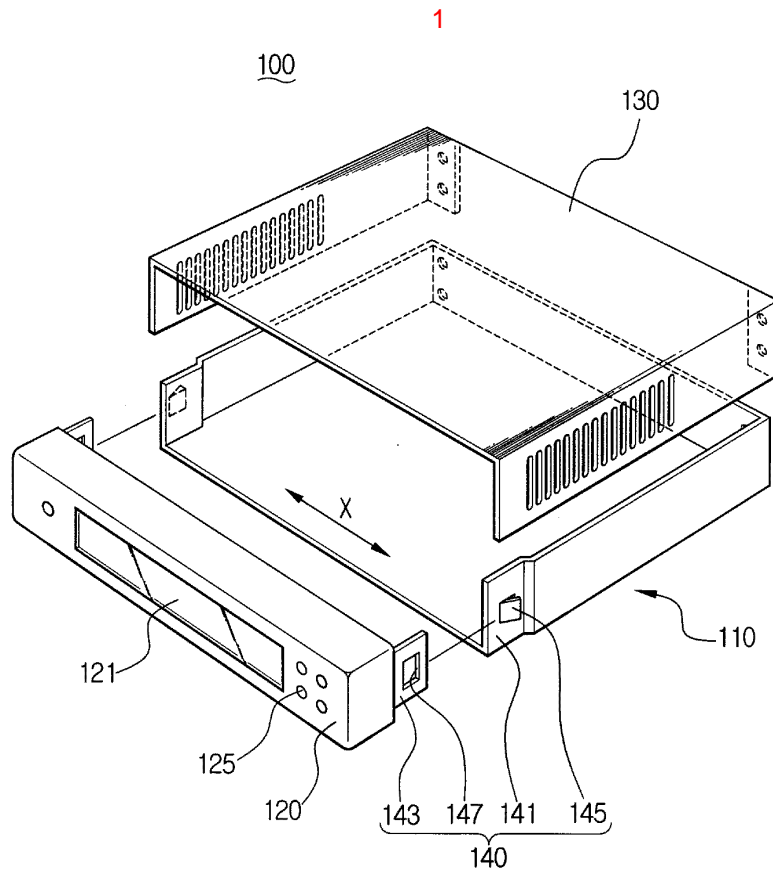

2a

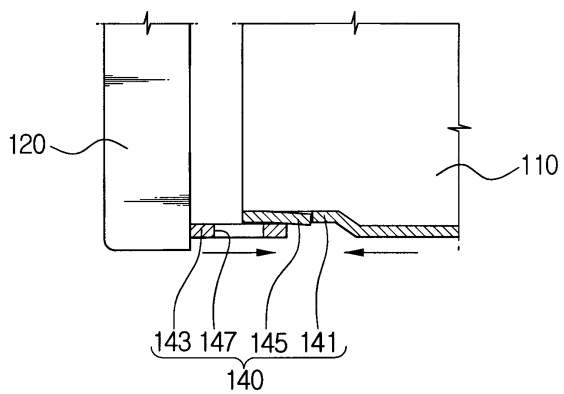

2b

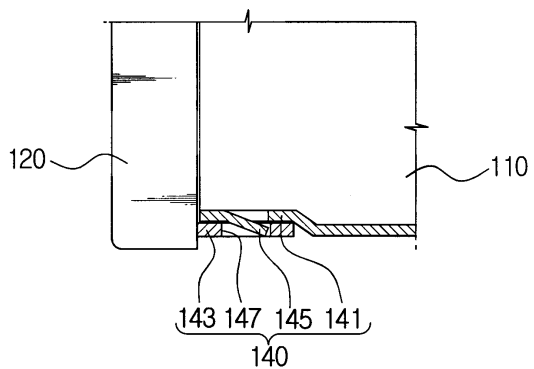

3

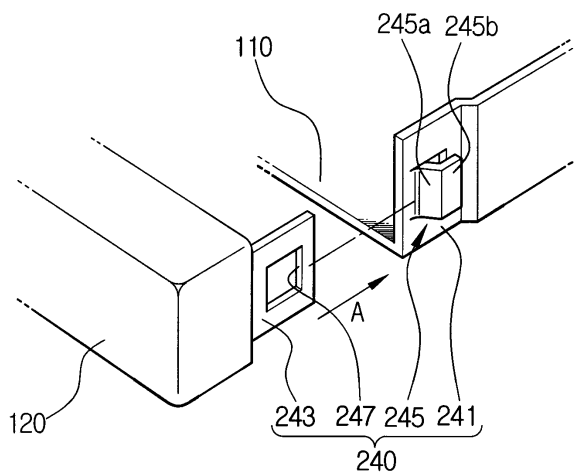

4

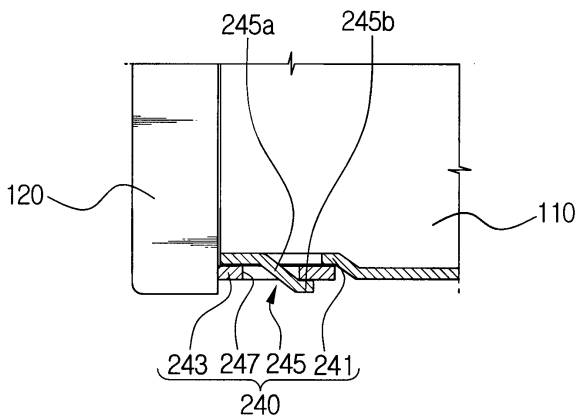

5

