



US 20020098762A1

(19) **United States**

(12) **Patent Application Publication**

Shelley et al.

(10) **Pub. No.: US 2002/0098762 A1**

(43) **Pub. Date: Jul. 25, 2002**

(54) **SHAPED CAPILLARY PRODUCTION OF HOMO FILAMENT CRIMP FIBERS**

(76) Inventors: **Jeffrey David Shelley**, Appleton, WI (US); **Jose Enrique Maldonado**, Canton, GA (US); **Braulio A. Polanco**, Canton, GA (US)

Correspondence Address:
Pauley Petersen Kinne & Erickson
2800 W. Higgins Road, Suite 365
Hoffman Estates, IL 60195 (US)

Related U.S. Application Data

(63) Non-provisional of provisional application No. 60/257,973, filed on Dec. 22, 2000.

Publication Classification

(51) **Int. Cl.⁷** **D01H 13/00**; D01H 9/00; D04H 1/00; D04H 3/00

(52) **U.S. Cl.** **442/336**; 442/337; 442/352; 442/359; 264/638; 57/112

(57) **ABSTRACT**

Robust homofilament fibers are meltspun from specially shaped capillaries to induce differential shear to induce crimping. Crimping may further be aided by directed quenching and drawing of the fibers.

(21) Appl. No.: **10/006,994**

(22) Filed: **Dec. 6, 2001**

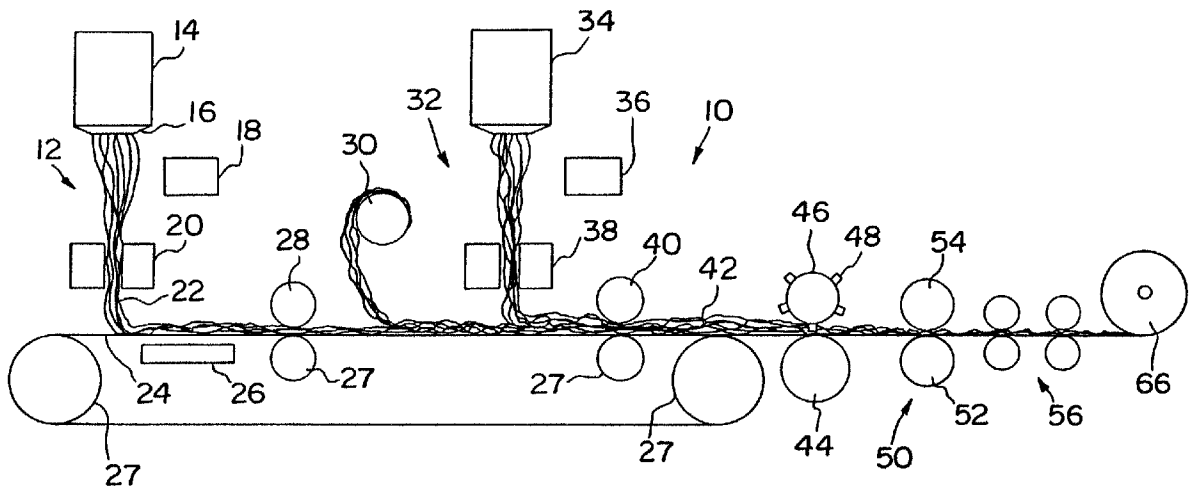

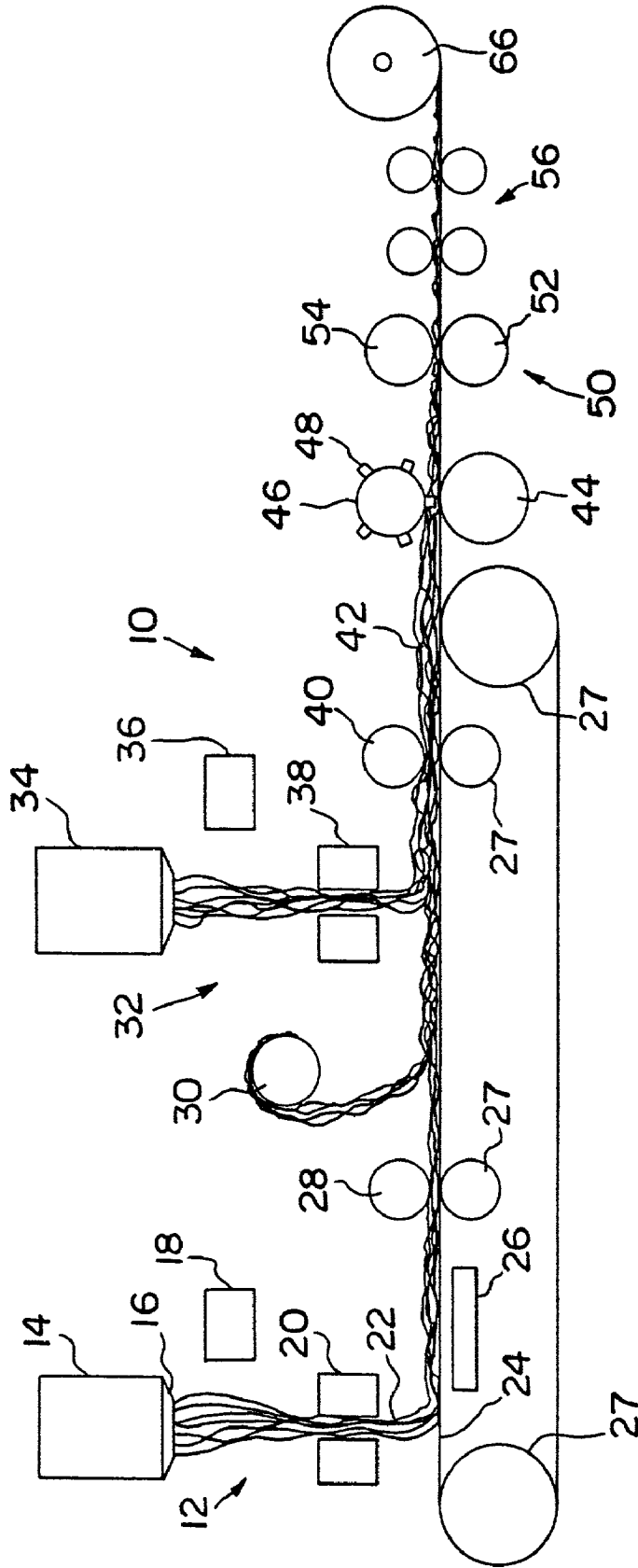
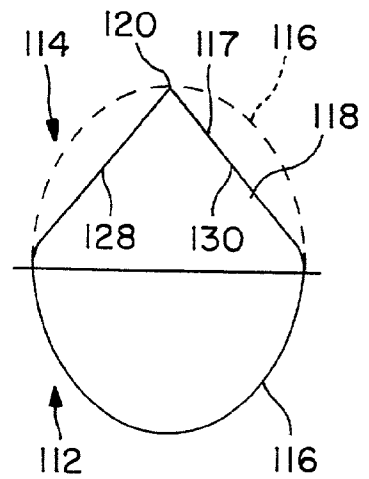
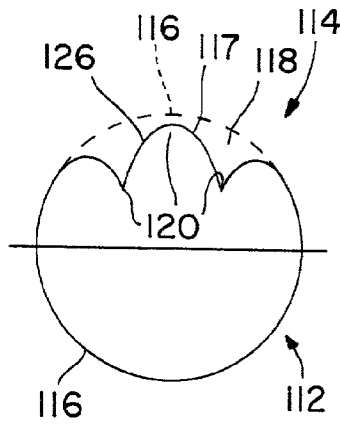
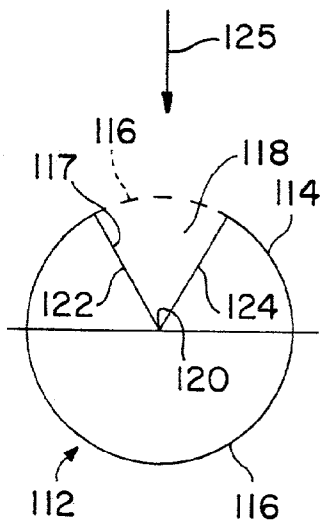
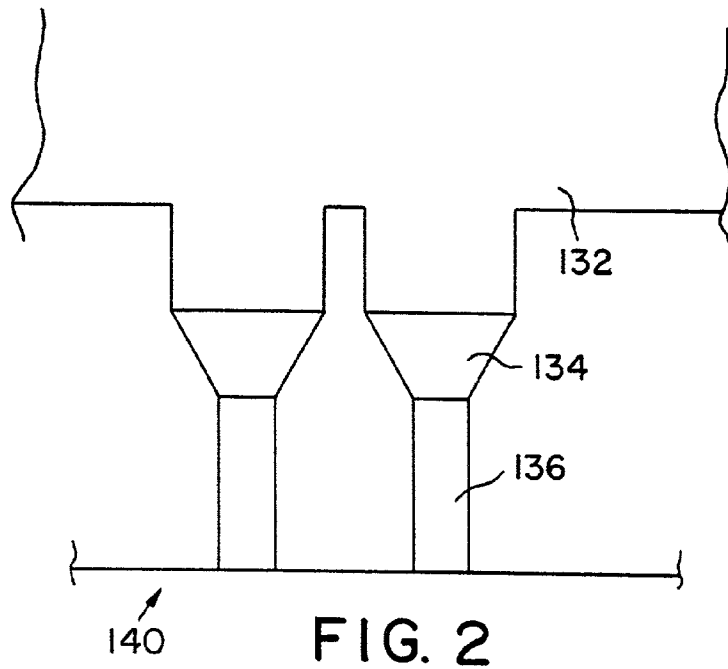

FIG. 1



SHAPED CAPILLARY PRODUCTION OF HOMOFILAMENT CRIMP FIBERS

FIELD OF THE INVENTION

[0001] The present invention relates generally to lofty nonwoven fiber webs. The present invention relates specifically to lofty nonwoven fiber webs of homofilament crimped fibers and methods for producing the fibers.

BACKGROUND OF THE INVENTION

[0002] Webs of homofilament crimped thermoplastic fibers are useful for various fluid handling or retaining materials and the like because of their open structure, resiliency, and economy of manufacture. Particularly, the use of a single thermoplastic polymer in the making of the crimped fibers is good for economical and consistent manufacture. However, the present state of the manufacturing art relies largely on bicomponent filaments to induce the desired level of crimping in a consistent fashion leading to certain compromises in the consistency of fabric characteristics and economy thereof.

[0003] In the known art several attempts have been made to produce crimping through shaped fibers. For example, U.S. Pat. No. 6,123,886 to Slack, at FIG. 6, shows a shaped fiber produced by extrusion of a single polymer through a shaped orifice. Spinnerettes having multiple orifices for a single fiber to produce the shaped fibers are also known. However the known art suffers in several regards. First, the known processing of the shaped fibers is not a robust process in that the fibers are not consistently shaped or the component parts of the fiber do not hold together well, resulting in less predictable web morphology and attendant functional characteristics. Second, the degree of crimping derived from using a single polymer to produce a crimped homofilament with known techniques has not consistently attained the desired level of crimp.

[0004] Therefore, there is a need in the art for a robust and easily accomplished means and method of manufacturing homofilament crimped fiber which has a high degree of crimp and good predictability of the fiber shape and crimping to yield the desired nonwoven web structure.

DEFINITIONS

[0005] Within the context of this specification, each term or phrase below will include the following meaning or meanings.

[0006] "Article" refers to a garment or other end-use article of manufacture, including but not limited to, diapers, training pants, swim wear, catamenial products, medical garments or wraps, and the like.

[0007] "Bonded" or "bonding" refers to the joining, adhering, connecting, attaching, or the like, of two elements. Two elements will be considered to be bonded together when they are bonded directly to one another or indirectly to one another, such as when each is directly bonded to intermediate elements.

[0008] "Connected" refers to the joining, adhering, bonding, attaching, or the like, of two elements. Two elements will be considered to be connected together when they are

connected directly to one another or indirectly to one another, such as when each is directly connected to intermediate elements.

[0009] "Disposable" refers to articles which are designed to be discarded after a limited use rather than being laundered or otherwise restored for reuse.

[0010] "Disposed," "disposed on," and variations thereof are intended to mean that one element can be integral with another element, or that one element can be a separate structure bonded to or placed with or placed near another element.

[0011] "Fabrics" is used to refer to all of the woven, knitted and nonwoven fibrous webs.

[0012] "Film" refers to a thermoplastic film made using a film extrusion and/or foaming process, such as a cast film or blown film extrusion process. The term includes apertured films, slit films, and other porous films which constitute liquid transfer films, as well as films which do not transfer liquid.

[0013] "Homofilament" refers to a fiber formed from only one predominate polymer and made from a single stream of that polymer. This is not meant to exclude fibers formed from one polymer to which small amounts of additives have been added for coloration, anti-static properties, lubrication, hydrophilicity, etc.

[0014] "Integral" or "integrally" is used to refer to various portions of a single unitary element rather than separate structures bonded to or placed with or placed near one another.

[0015] "Layer" when used in the singular can have the dual meaning of a single element or a plurality of elements.

[0016] "Machine direction" refers to the length of a fabric in the direction in which it is produced, as opposed to "cross direction" which refers to the width of a fabric in a direction generally perpendicular to the machine direction.

[0017] "Meltblown fiber" means fibers formed by extruding a molten thermoplastic material through a plurality of fine, usually circular, die capillaries as molten threads or filaments into converging high velocity heated gas (e.g., air) streams which attenuate the filaments of molten thermoplastic material to reduce their diameter, which may be to microfiber diameter. Thereafter, the meltblown fibers are carried by the high velocity gas stream and are deposited on a collecting surface to form a web of randomly dispersed meltblown fibers. Such a process is disclosed for example, in U.S. Pat. No. 3,849,241 to Butin et al. Meltblown fibers are microfibers which may be continuous or discontinuous, are generally smaller than about 0.6 denier, and are generally self bonding when deposited onto a collecting surface. Meltblown fibers used in the present invention are preferably substantially continuous in length.

[0018] "Meltspun" refers generically to a fiber which is formed from a molten polymer by a fiber-forming extrusion process, for example, such as are made by the meltblown and spunbond processes.

[0019] "Member" when used in the singular can have the dual meaning of a single element or a plurality of elements.

[0020] “Nonwoven” and “nonwoven web” refer to materials and webs of material which are formed without the aid of a textile weaving or knitting process.

[0021] “Polymers” include, but are not limited to, homopolymers, copolymers, such as for example, block, graft, random and alternating copolymers, terpolymers, etc. and blends and modifications thereof. Furthermore, unless otherwise specifically limited, the term “polymer” shall include all possible geometrical configurations of the material. These configurations include, but are not limited to isotactic, syndiotactic and atactic symmetries.

[0022] Words of degree, such as “About”, “Substantially”, and the like are used herein in the sense of “at, or nearly at, when given the manufacturing and material tolerances inherent in the stated circumstances” and are used to prevent the unscrupulous infringer from unfairly taking advantage of the invention disclosure where exact or absolute figures are stated as an aid to understanding the invention.

[0023] “Substantially circular or elliptical cross sectional shape” refers herein to the virtual cross section of an irregularly shaped capillary having a cross section with part of its outer wall defined by a definite radius, if circular, or focal points, if elliptical; with the virtual cross section defined by the boundaries of such a circle or ellipse when continued around or through a portion of the capillary sidewall not defined by the radius or focal points.

[0024] “Spunbond fiber” refers to small diameter fibers which are formed by extruding molten thermoplastic material as filaments from a plurality of fine capillaries of a spinnerette having a circular or other configuration, with the diameter of the extruded filaments then being rapidly reduced as by, for example, in U.S. Pat. No. 4,340,563 to Appel et al., and U.S. Pat. No. 3,692,618 to Dorschner et al., U.S. Pat. No. 3,802,817 to Matsuki et al., U.S. Pat. Nos. 3,338,992 and 3,341,394 to Kinney, U.S. Pat. No. 3,502,763 to Hartmann, U.S. Pat. No. 3,502,538 to Petersen, and U.S. Pat. No. 3,542,615 to Dobo et al., each of which is incorporated herein in its entirety by reference. Spunbond fibers are quenched and generally not tacky when they are deposited onto a collecting surface. Spunbond fibers are generally continuous and often have average deniers larger than about 0.3, more particularly, between about 0.6 and 10.

[0025] “Surface” includes any layer, film, woven, nonwoven, laminate, composite, or the like, whether pervious or impervious to air, gas, and/or liquids.

[0026] “Thermoplastic” describes a material that softens when exposed to heat and which substantially returns to a nonsoftened condition when cooled to room temperature.

[0027] These terms may be defined with additional language in the remaining portions of the specification.

SUMMARY OF THE INVENTION

[0028] A homofilament crimped fiber is produced by a differentially stressed polymer stream exiting through a shaped capillary design. Differently induced shear in the polymer stream results in differential tensions in the filament causing crimp. The filaments may further be subjected to differential or directed quenching which provides for setting the crimps in the filaments to further induce the crimp. The crimped fibers made according to the present invention can

be useful for high loft and high bulk applications such as the loop portions of hook and loop fasteners when designed for engageability with the hook portions, or if a natural fabric cloth-like feel is desired, the fibers may be designed to produce fabric of good softness and drape while keeping sufficient bulk and loft to aid in the cloth like feel. The crimped fibers of the present invention may further be useful for making fabrics which are extensible largely in the cross direction of the resultant nonwoven web. Due to the shape of the fibers certain function or esthetic characteristics such as visual appearance and fiber strength may also be enhanced. The present invention will further allow the use of polypropylene polymers to produce the homofilament crimped fibers.

[0029] Specific shapes of spinnerette capillaries and methodologies for using those shapes will be further elaborated on below.

BRIEF DESCRIPTION OF THE DRAWINGS

[0030] FIG. 1 shows a known apparatus of the general environment used for manufacturing filaments according to the present invention.

[0031] FIG. 2 is a schematic representation of a cross sectional view of the fiber forming capillaries and surrounding elements of a meltspun die head.

[0032] FIG. 3 is a first exemplary capillary shape for producing crimped homofilament fibers according to the present invention.

[0033] FIG. 4 is a second exemplary capillary shape for producing crimped homofilament fibers according to the present invention.

[0034] FIG. 5 is a third exemplary capillary shape for producing crimped homofilament fibers according to the present invention.

DETAILED DESCRIPTION OF THE PRESENTLY PREFERRED EMBODIMENTS

[0035] The present invention provides a method of producing homofilament helical crimped fibers for a nonwoven web. The present invention is usable with meltspun polymers known to those skilled in the art and most surprisingly works well with polypropylene polymers which are not generally considered good crimped fiber material. In general, the means and method of the present invention comprise using a shaped capillary for inducing differential shear between the polymer flowing in a substantially hemispherical, or half round, half of the capillary and the polymer flowing in the nonhemispherical, or shaped, half of that capillary. The method may further include differential or directed quenching of the filaments, with the directed quenching air aimed at the shaped portion of the fiber.

[0036] In a preferred embodiment of the present invention, the fibers may be formed of resin which is preferably a thermoplastic polypropylene polymer. Other polymers such as, but not limited to, polyolefins, polyesters, polyamides, polyurethanes, copolymers and mixtures thereof might also be used in accordance with certain aspects of the present invention.

[0037] FIG. 1 shows an apparatus of the general environment used for manufacturing filaments, or “fibers” as used

synonymously therewith, according to the present invention. Apparatus **10** has a first extruder assembly **12** for producing spunbond fibers in accordance with known methods (also see U.S. Pat. No. 5,382,400 to Pike et al.). A spinneret **14** is supplied with molten polymer resin from a resin source (not shown). The spinneret **14** produces fine denier fibers from the exit **16**, which are quenched by an air stream supplied by a quench blower **18**. The air stream may differentially cool one side of the fiber stream more than the other side, thus causing bending and crimping of the fibers. Crimping, as discussed in general hereinabove, creates a softer fabric by reducing the "straightness" of the fibers, between bond points created in the thermal bonding step, as well as fiber-to-fiber bonds. Various parameters of the quench blower **18** can be controlled to control the quality and quantity of crimping. Fiber composition and resin selection also determine the crimping characteristics imparted.

[0038] The filaments are drawn into a fiber drawing unit or aspirator **20** having a Venturi tube/channel **22**, through which the fibers pass. The tube is supplied with temperature controlled air, which attenuates the filaments as they are pulled through the fiber drawing unit **20** in their plastic state. The attenuated fibers are then deposited onto a foraminous moving collection belt **24** and retained on the belt **24** by a vacuum force exerted by a vacuum box **26**. The belt **24** travels around guide rollers **27**. As the fibers move along on the belt **24**, a compaction roll **28** above the belt, which operates with one of the guide rollers **27** beneath the belt, compresses the spunbond mat so that the fibers have sufficient integrity to go through the manufacturing process.

[0039] As shown in FIG. 2, a die tip **140** defines a polymer supply passage **132** that terminates in further passages defined by counterbores **134** leading to exit passages in the die tip **140** which are known as capillaries **136**. Capillaries **136** are individual passages formed in and along the length of die tip **140**. Generally, the capillaries of the present invention have a length to width ratio of between about 6:1 and 10:1; with length being defined in the direction of polymer flow and width being the capillary diameter.

[0040] As explained above, each individual filament is produced by a capillary through which the plastic liquid polymer extrudate is forced. FIGS. 3-5 detail exemplary embodiments of these capillary shapes according to the present invention.

[0041] As seen in FIGS. 3-5 each capillary cross sectional shape has a substantially hemispherical, or half round, half **112** and a substantially nonhemispherical, shaped or non round, half **114**. Overall, each capillary will be said to have a substantially round, or in the case of FIG. 5, elliptical, cross sectional shape. The nonround half of each capillary shape may be seen to have a cut out area **118** of the otherwise substantially round, or in the case of FIG. 5, elliptical, cross sectional shape. "Round" and "elliptical" will hereinafter collectively be referred to as "round" for ease of explanation. The shaped outer border **117** is contiguous with the round outer border **116** and defines the cutaway portion **118**, which is not more than 25% of the entire area within the substantially round outer boundary **116**. It will also be noted that each capillary shape nonround half **114** forms at least one point or angle therein, collectively **120**, for forming a point on an outer surface of an extruded fiber.

[0042] Referencing FIG. 3, it can be seen that the cutaway portion is formed by two radiuses **122**, **124** separated by

approximately 60°. Referencing FIG. 4, it can be seen that the cutaway portion is formed by crenulations **126** of the outer border which resemble a "tulip" or "w" shape. Referencing FIG. 5, it can be seen that the cutaway portion is formed by two chords **128**, **130** within the outer border of generally elliptical shape thereby forming a substantially tear drop shaped outer border of the shaped capillary.

[0043] It is believed that removal of less than 25% of the cross sectional area of the otherwise substantially round cross section of the capillary aids in the retention of substantially circular cross section while inducing the necessary shear differential between the round and nonround halves of the capillaries and provides for a robust fiber.

[0044] Further, during processing of the extrudate, quenching fluid directed at the nonround half of the fibers, i.e. from the general direction of arrow **125** in FIG. 3, is believed to best help fix the stress differentials induced by the shaped capillary and aid in overall crimping.

[0045] Having thus described means and method for producing homofilament crimped thermoplastic fibers through the use of shaped capillaries, it will be appreciated that while this invention has been described in relation to certain preferred embodiments thereof, and many details have been set forth for purpose of illustration, it will be apparent to those skilled in the art that the invention is susceptible to additional embodiments and that certain of the details described herein can be varied considerably without departing from the basic principles of the invention.

We claim:

1. A spinneret design for producing a crimped homofilament fiber comprising:

- a) an extruder for forcing a liquid polymer through a spinneret capillary;
- b) the capillary having one of a substantially circular or elliptical cross sectional shape with a cut out of less than 25 percent of a surface area of the cross sectional shape; and
- c) the cut out area being contiguous with an outer boundary of the cross sectional shape and forming at least one point on an outer surface of the fiber.

2. The spinneret design of claim 1 wherein the capillary has a length to width ratio of between about 6:1 to about 10:1.

3. The spinneret design of claim 1 wherein the capillary is connected to a polymer supply passage by a counterbore.

4. A nonwoven web comprising:

a plurality of crimped fibers,

each fiber having one of a substantially circular or elliptical cross sectional shape with a cut out of less than 25 percent of a surface area of the cross sectional shape; and

the cut out area being contiguous with the outer boundary of the cross sectional shape and forming at least one point on an outer surface of the fiber.

5. The nonwoven web of claim 4 wherein the fibers are polypropylene.

6. A process for making crimped fibers, comprising the step of:

extruding each of the fibers through a capillary having one of a substantially circular or elliptical cross sectional shape with a cut out of less than 25 percent of a surface area of the cross sectional shape; and

the cut out area being contiguous with the outer boundary of the cross sectional shape and forming at least one point on an outer surface of the fiber.

7. The process for making crimped fibers according to claim 6, further comprising the step of: directing quenching fluid primarily at the cutout area of the fiber.

8. The process for making crimped fibers according to claim 7, further comprising the step of: drawing the fibers

while in their plastic state to produce fibers with a substantially round cross section.

9. The process for making crimped fibers according to claim 6, further comprising the step of: drawing the fibers while in their plastic state to produce fibers with a substantially round cross section.

10. The process for making crimped fibers of claim 6 wherein the fibers are polypropylene.

11. The process for making crimped fibers of claim 8 wherein the fibers are polypropylene.

* * * * *